

Automotive fully integrated H-bridge motor driver

Datasheet - production data

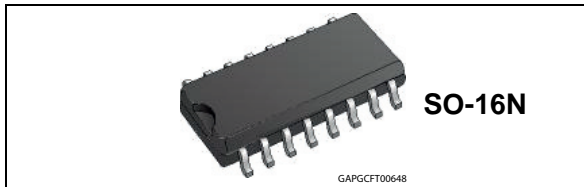

Features

Type	$R_{DS(on)}$	I_{out}	V_{CCmax}
VNH7070AS	70 m Ω typ (per leg)	15 A	41 V

- Automotive qualified
- Output current: 15 A
- 3 V CMOS-compatible inputs
- Undervoltage shutdown
- Overvoltage clamp
- Thermal shutdown
- Cross-conduction protection
- Current and power limitation
- Very low standby power consumption
- Protection against loss of ground and loss of V_{CC}
- PWM operation up to 20 kHz
- CS diagnostic functions
 - Analog motor current feedback
 - Output short to ground detection
 - Thermal shutdown indication
 - OFF-state open-load detection
 - Output short to V_{CC} detection
- Output protected against short to ground and short to V_{CC}
- Standby Mode
- Half Bridge Operation
- Package: ECOPACK[®]

Description

The device is a full bridge motor driver intended for a wide range of automotive applications. The device incorporates a dual monolithic high-side driver and two low-side switches.

Both switches are designed using STMicroelectronics' well known and proven proprietary VIPower[®] M0-7 technology that allows to efficiently integrate on the same die a true Power MOSFET with an intelligent signal/protection circuitry. The three dies are assembled in SO-16N package on electrically isolated lead-frames.

Moreover, its fully symmetrical mechanical design allows superior manufacturability at board level. The input signals IN_A and IN_B can directly interface the microcontroller to select the motor direction and the brake condition. A SEL0 pin is available to address the information available on the CS to the microcontroller. The CS pin allows to monitor the motor current by delivering a current proportional to the motor current value. The PWM, up to 20 kHz, allows to control the speed of the motor in all possible conditions. In all cases, a low level state on the PWM pin turns off both the LS_A and LS_B switches.

Table 1. Device summary

Package	Order codes	
	Tube	Tape and reel
SO-16N	—	VNH7070ASTR

Contents

- 1 Block diagram and pin description 5**

- 2 Electrical specifications 7**
 - 2.1 Absolute maximum ratings 7
 - 2.2 Thermal data 8
 - 2.3 Electrical characteristics 9
 - 2.4 Waveforms 20

- 3 Application information 22**
 - 3.1 Reverse battery protection 23
 - 3.2 OFF-state open-load detection – External circuitry dimensioning 23
 - 3.3 Immunity against transient electrical disturbances 24
 - 3.4 Device configurations 25

- 4 Package and PCB thermal data 27**
 - 4.1 SO16-N thermal data 27
 - 4.2 Package thermal data 28
 - 4.2.1 Thermal characterization in steady state conditions 28
 - 4.2.2 Thermal characterization during transients 29

- 5 Package and packing information 33**
 - 5.1 SO-16N mechanical data 33
 - 5.2 SO-16N packing information 34
 - 5.3 SO-16N marking information 36

- 6 Revision history 37**



List of tables

Table 1. Device summary 1

Table 2. Block description 5

Table 3. Pin definitions and functions 6

Table 4. Absolute maximum ratings 7

Table 5. Thermal data 8

Table 6. Power section 9

Table 7. Logic inputs (IN_A, IN_B) (V_{CC} = 7 V up to 28 V; -40 °C < T_j < 150 °C) 10

Table 8. Switching (V_{CC} = 13 V, R_{LOAD} = 3.7 Ω) 10

Table 9. Protections and diagnostics (V_{CC} = 7 V up to 18 V; -40 °C < T_j < 150 °C) 11

Table 10. CS (7 V < V_{CC} < 18 V) 12

Table 11. Operative condition - truth table 18

Table 12. On-state fault conditions- truth table Fault on leg A (preliminary) 18

Table 13. Off-state -truth table 19

Table 14. ISO 7637-2 - electrical transient conduction along supply line 24

Table 15. Thermal model for junction temperature calculation in steady-state conditions\ 29

Table 16. Thermal parameters 31

Table 17. SO-16N mechanical data 34

Table 18. Reel dimensions 35

Table 19. SO-16N carrier tape dimensions 35

Table 20. Document revision history 37

List of figures

Figure 1.	Block diagram	5
Figure 2.	Configuration diagram (top view)	6
Figure 3.	Current and voltage conventions	7
Figure 4.	T_{DSTKON}	13
Figure 5.	Definition of the low-side switching times	14
Figure 6.	Definition of the high-side switching times	14
Figure 7.	Low-side turn-on delay time	15
Figure 8.	Time to shutdown for the low-side driver	15
Figure 9.	Input reset time for HSD - fault unlatch	16
Figure 10.	Input reset time for LSD - fault unlatch	16
Figure 11.	OFF-state diagnostic delay time from rising edge of V_{OUT} (t_{D_VOL})	17
Figure 12.	Normal operative conditions	20
Figure 13.	OUT shorted to ground and short clearing	20
Figure 14.	OUT shorted to V_{CC} and short clearing	21
Figure 15.	Application schematic with reverse battery protection connected to V_{batt}	22
Figure 16.	Application schematic with reverse battery protection connected to GND	22
Figure 17.	Suggested PCB layout	23
Figure 18.	Half-bridge configuration (case a)	25
Figure 19.	Half-bridge configuration (case b)	25
Figure 20.	Multi-motors configuration	26
Figure 21.	PCB layout (top and bottom): footprint, 2+2+2 cm^2 , 8+8+8 cm^2	27
Figure 22.	PCB 4 layer	28
Figure 23.	Chipset configuration configuration in steady state conditions	28
Figure 24.	Auto and mutual $R_{thj-amb}$ vs. PCB heat-sink area in open box free air condition	29
Figure 25.	HSD thermal impedance junction ambient single pulse	30
Figure 26.	LSD thermal impedance junction ambient single pulse	30
Figure 27.	Electrical equivalent model	31
Figure 28.	SO-16N package dimensions	33
Figure 29.	SO-16N reel 13"	34
Figure 30.	SO-16N rcarrier tape	35
Figure 31.	SO-16N schematic drawing of leader and trailer tape	36
Figure 32.	SO-16N marking information	36

1 Block diagram and pin description

Figure 1. Block diagram

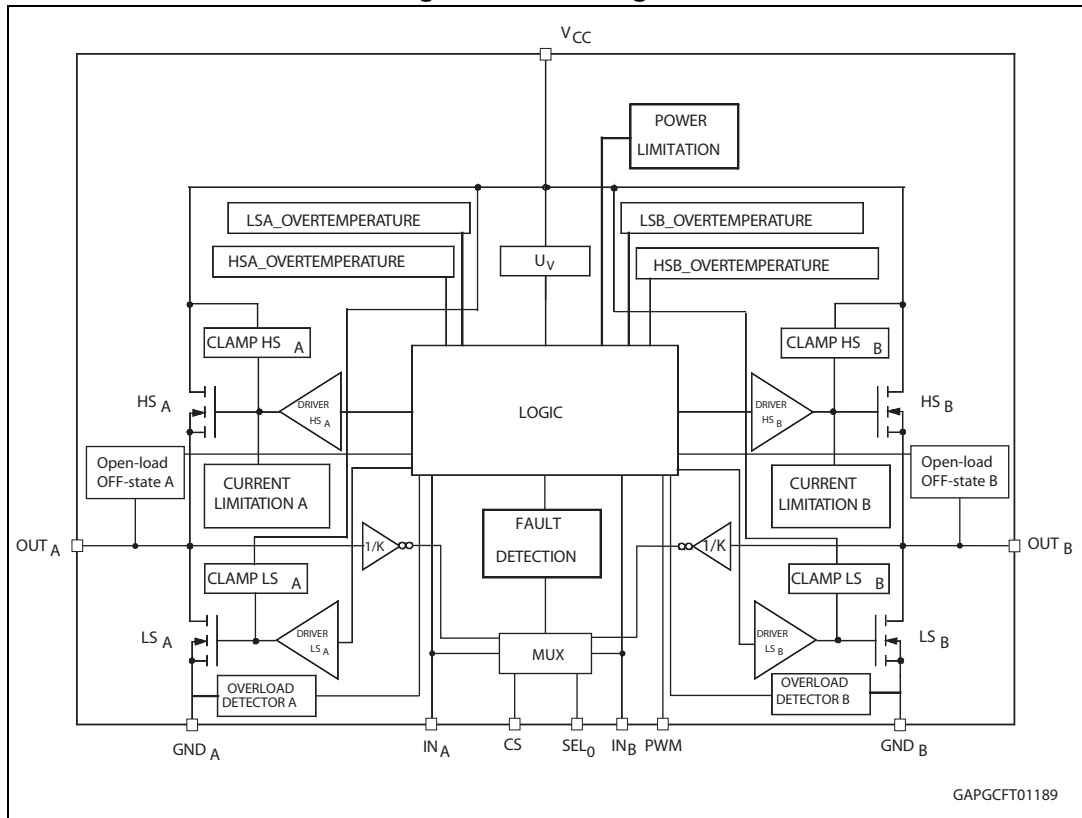

Table 2. Block description

Name	Description
Logic control	Allows the turn-on and the turn-off of the high-side and the low-side switches according to the truth table.
Undervoltage	Shuts down the device for battery voltage lower than 4 V.
High-side and low-side clamp voltage	Protect the high-side and the low-side switches from the high voltage on the battery line.
High-side and low-side driver	Drive the gate of the concerned switch to allow a proper R_{on} for the leg of the bridge.
Current limitation	Limits the motor current in case of short circuit.
High-side and low-side overtemperature protection	In case of short-circuit with the increase of the junction temperature, it shuts down the concerned driver to prevent degradation and to protect the die.
Low-side overload detector	Detects when low side current exceeds shutdown current and latches off the concerned Low side.

Table 2. Block description (continued)

Name	Description
Fault detection	Signalizes the abnormal behavior of the switch through CS pin.
Power limitation	Limits the power dissipation of the high-side driver inside safe range in case of short to ground condition.

Figure 2. Configuration diagram (top view)

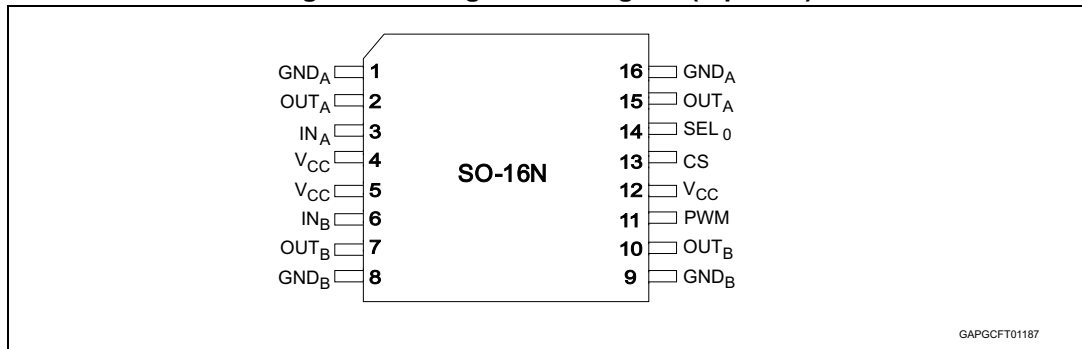
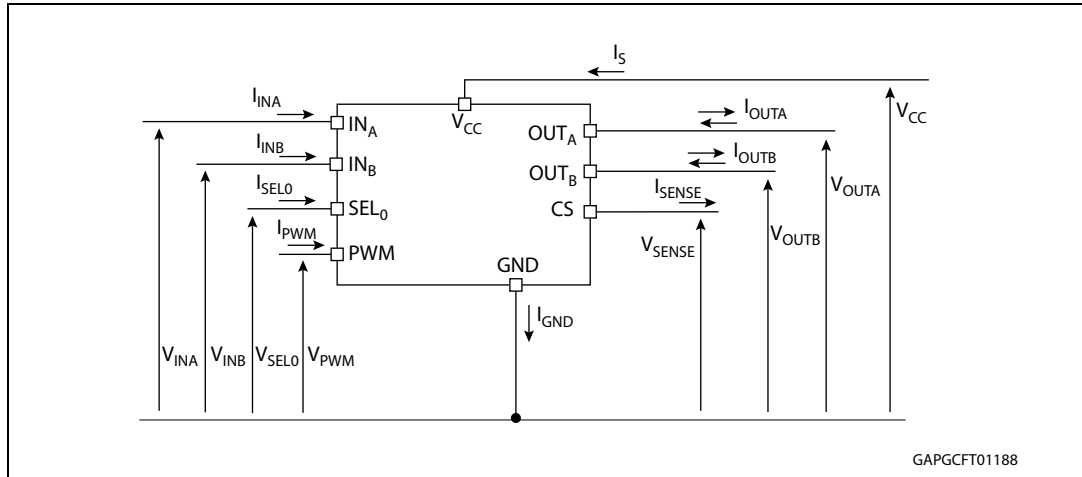

Table 3. Pin definitions and functions

Pin N°	Symbol	Function
1, 16	GND _A	Source of low-side switch A
2, 15	OUT _A	Source of high-side switch A / drain of low-side switch A
3	IN _A	Clockwise input
4, 5, 12	V _{CC}	Power supply voltage
6	IN _B	Counter clockwise input
7, 10	OUT _B	Source of high-side switch B / drain of low-side switch B
8, 9	GND _B	Source of low-side switch B
11	PWM	Voltage controlled input pin with hysteresis, CMOS compatible. Gates of low-side FETS get modulated by the PWM signal during their on phase allowing speed control of the motor
13	CS	Multiplexed analog sense output pin; it delivers a current proportional to the motor current according to the leg selection.
14	SEL ₀	Active high compatible with 3 V and 5 V CMOS outputs pin; in combination with IN _A , IN _B , it addresses the CurrentSense information delivered to the micro according to the operative truth table.

2 Electrical specifications

Figure 3. Current and voltage conventions



GAPGCFT01188

2.1 Absolute maximum ratings

Stressing the device above the rating listed in [Table 4: Absolute maximum ratings](#) may cause permanent damage to the device. These are stress ratings only and operation of the device at these or any other conditions above those indicated in the Operating sections of this specification is not implied. Exposure to Absolute Maximum Rating conditions for extended periods may affect device reliability.

Table 4. Absolute maximum ratings

Symbol	Parameter	Value	Unit
V_{CC}	Supply voltage	38	V
$-V_{CC}$	Reverse DC Supply Voltage	0.3	V
I_{max}	Maximum output current (continuous)	Internally limited	A
I_R	Reverse output current (continuous)	-15	A
V_{CCPK}	Maximum transient supply voltage (ISO 16750-2:2010 Test B clamped to 40 V; $R_L = 4 \Omega$)	40	V
V_{CCJS}	Maximum jump start voltage for single pulse short circuit protection	28	V
I_{IN}	Input current (IN_A and IN_B pins)	-1 to 10	mA
I_{SELO}	SEL_0 DC input current	-1 to 10	mA
I_{PWM}	PWM input current	-1 to 10	mA
I_{SENSE}	CS pin DC output current ($V_{GND} = V_{CC}$ and $V_{SENSE} < 0 V$)	10	mA
	CS pin DC output current in reverse ($V_{CC} < 0 V$)	-20	

Table 4. Absolute maximum ratings (continued)

Symbol	Parameter	Value	Unit
V _{ESD}	Electrostatic discharge (Human body model: R = 1.5 kΩ; C = 100 pF) – IN _A , IN _B , PWM	2	kV
	– SEL ₀	2	
	– CS	2	
	– V _{CC}	4	
	– Output	4	
V _{ESD}	Charge device model (CDM-AEC-Q100-011)	750	V
T _c	Junction operating temperature	-40 to 150	°C
T _{STG}	Storage temperature	-55 to 150	°C

2.2 Thermal data

Table 5. Thermal data

Symbol	Parameter		Max. value	Unit
R _{thj-pin}	Thermal resistance junction-pin	HSD	31	°C/W
		LSD	44	°C/W
R _{thj-amb}	Thermal resistance junction-ambient (JEDEC JESD 51-2) ⁽¹⁾		See Figure 24	°C/W
R _{thj-amb}	Thermal resistance junction-ambient (JEDEC JESD 51-2) ⁽²⁾	HSD	39.5	°C/W
		LSD	55	°C/W

1. Device mounted on two-layers 2s0p PCB.
2. Device mounted on four-layers 2s2p PCB.

2.3 Electrical characteristics

Values specified in this section are for $V_{CC} = 7\text{ V}$ up to 28 V ; $-40\text{ °C} < T_j < 150\text{ °C}$, unless otherwise specified.

Table 6. Power section

Symbol	Parameter	Test conditions	Min.	Typ.	Max.	Unit
V_{CC}	Operating supply voltage		4		28	V
I_S	Supply current	Off-state - standby; $I_{N_A} = I_{N_B} = 0$; $SEL_0 = 0$; PWM = 0; $T_j = 25\text{ °C}$; $V_{CC} = 13\text{ V}$			1	μA
		Off-state - standby; $I_{N_A} = I_{N_B} = 0$; $SEL_0 = 0$; PWM = 0; $V_{CC} = 13\text{ V}$; $T_j = 85\text{ °C}$			1	μA
		Off-state - standby; $I_{N_A} = I_{N_B} = 0$; $SEL_0 = 0$; PWM = 0; $V_{CC} = 13\text{ V}$; $T_j = 125\text{ °C}$			3	μA
		Off-state (no standby); $I_{N_A} = I_{N_B} = 0$; $SEL_0 = 5\text{ V}$; PWM = 0		2	4	mA
		On-state: I_{N_A} or $I_{N_B} = 5\text{ V}$; PWM = 0 V or PWM=5 V; $SEL_0 = X$		3.5	6	mA
$t_{D_sdb\text{y}}^{(1)}$	Standby mode blanking time	$V_{CC} = 13\text{ V}$; $I_{N_A} = I_{N_B} = 0$; PWM = 0 V; V_{SEL0} from 5 V to 0 V	0.2	1	1.8	ms
R_{ONHS}	Static high-side resistance	$I_{OUT} = 3.5\text{ A}$; $T_j = 25\text{ °C}$		42		$\text{m}\Omega$
		$I_{OUT} = 3.5\text{ A}$; $T_j = -40\text{ to }150\text{ °C}$			85	$\text{m}\Omega$
R_{ONLS}	Static low-side resistance	$I_{OUT} = 3.5\text{ A}$; $T_j = 25\text{ °C}$		30		$\text{m}\Omega$
		$I_{OUT} = 3.5\text{ A}$; $T_j = -40\text{ °C to }150\text{ °C}$			60	$\text{m}\Omega$
V_f	Free-wheeling diode forward voltage	$I_{OUT} = -3.5\text{ A}$; $T_j = 150\text{ °C}$		0.7	0.9	V
$I_{L(off)}$	Off-state output current of one leg	$I_{N_A} = I_{N_B} = 0$; PWM = 0; $V_{CC} = 13\text{ V}$; $T_j = 25\text{ °C}$	0		0.5	μA
		$I_{N_A} = I_{N_B} = 0$; PWM = 0; $V_{CC} = 13\text{ V}$; $T_j = 125\text{ °C}$	0		3	μA
$I_{L(off_h)}$	Off-state output current of one leg with other HSD on	$I_{N_A} = 0$; $I_{N_B} = 5\text{ V}$; PWM = 0; $V_{CC} = 13\text{ V}$	20		60	μA

1. To power on the device from the standby, it is recommended to:
 — toggle I_{N_A} or I_{N_B} from 0 to 1 first to come out from STBY mode
 — toggle PWM from 0 to 1 with a delay of $20\text{ }\mu\text{s}$
 this avoids any over-stress on the device in case of existing short-to-battery.

Table 7. Logic inputs (I_{N_A} , I_{N_B}) ($V_{CC} = 7\text{ V up to } 28\text{ V}$; $-40\text{ }^\circ\text{C} < T_j < 150\text{ }^\circ\text{C}$)

Symbol	Parameter	Test conditions	Min.	Typ.	Max.	Unit
V_{IL}	Input low level voltage				0.9	V
V_{IH}	Input high level voltage		2.1			V
V_{IHYST}	Input hysteresis voltage		0.2			V
V_{ICL}	Input clamp voltage	$I_{IN} = 1\text{ mA}$	5.3		7.2	V
		$I_{IN} = -1\text{ mA}$		-0.7		V
I_{INL}	Input current	$V_{IN} = 0.9\text{ V}$	1			μA
I_{INH}	Input current	$V_{IN} = 2.1\text{ V}$			10	μA
SEL₀ ($V_{CC} = 7\text{ V up to } 18\text{ V}$; $-40\text{ }^\circ\text{C} < T_j < 150\text{ }^\circ\text{C}$)						
V_{SELL}	Input low level voltage				0.9	V
I_{SELL}	Low level input current	$V_{SEL} = 0.9\text{ V}$	1			μA
V_{SELH}	Input high level voltage		2.1			V
I_{SELH}	High level input current	$V_{SEL} = 2.1\text{ V}$			10	μA
$V_{SEL(hyst)}$	Input hysteresis voltage		0.2			V
V_{SELCL}	Input clamp voltage	$I_{SEL} = 1\text{ mA}$	5.3		7.5	V
		$I_{SEL} = -1\text{ mA}$		-0.7		V
PWM ($V_{CC} = 7\text{ V up to } 28\text{ V}$; $-40\text{ }^\circ\text{C} < T_j < 150\text{ }^\circ\text{C}$)						
V_{PWM}	Input low level voltage				0.9	V
I_{PWM}	Low level input current	$V_{PMW} = 0.9\text{ V}$	1			μA
V_{PWM}	Input high level voltage		2.1			V
I_{PWMH}	High level input current	$V_{PMW} = 2.1\text{ V}$			10	μA
$V_{PWM(hyst)}$	Input hysteresis voltage		0.2			V
V_{PMWCL}	Input clamp voltage	$I_{PMW} = 1\text{ mA}$	5.3		7.2	V
		$I_{PMW} = -1\text{ mA}$		-0.7		V

Table 8. Switching ($V_{CC} = 13\text{ V}$, $R_{LOAD} = 3.7\text{ }\Omega$)

Symbol	Parameter	Test conditions	Min.	Typ.	Max.	Unit
f	PWM frequency		0		20	kHz
$t_{d(on)}$	Turn-on delay time	Input rise time $< 1\text{ }\mu\text{s}$ (see Figure 6)		25		μs
$t_{d(off)}$	Turn-off delay time	Input rise time $< 1\text{ }\mu\text{s}$ (see Figure 6)		15		μs
t_r	Rise time	See Figure 5		0.7	2	μs
t_f	Fall time	See Figure 5		0.2	2	μs
t_{cross}	Low-side turn-on delay time	Input rise time $< 1\text{ }\mu\text{s}$ (see Figure 7)	40	140	350	μs

Table 9. Protections and diagnostics ($V_{CC} = 7\text{ V}$ up to 18 V ; $-40\text{ }^{\circ}\text{C} < T_j < 150\text{ }^{\circ}\text{C}$)

Symbol	Parameter	Test conditions	Min.	Typ.	Max.	Unit
V_{USD}	Undervoltage shutdown				4	V
$V_{USDreset}$	Undervoltage shutdown reset				5	V
$V_{USDHyst}$	Undervoltage shutdown Hysteresis			0.4		V
I_{LIM_H}	High-side current limitation		15	22	30	A
I_{SD_LS}	Shutdown LS current		18	27	36	A
t_{SD_LS}	Time to shutdown for the low-side	$IN_A = 5\text{ V}$; $IN_B = 0\text{ V}$; PWM = 5 V (see Figure 8)		5		μs
V_{CL_HSD}	High-side clamp voltage (V_{CC} to $OUT_A = 0$ or $OUT_B = 0$)	$I_{OUT} = 100\text{ mA}$; $t_{clamp} = 1\text{ ms}$	38	46		V
V_{CL_LSD}	Low-side clamp voltage ($OUT_A = V_{CC}$ or $OUT_B = V_{CC}$ to GND)	$I_{OUT} = 100\text{ mA}$; $t_{clamp} = 1\text{ ms}$	38	46		V
T_{TSD_HS}	High-side thermal shutdown temperature	$IN_x = 2.1\text{ V}$	150	175	200	$^{\circ}\text{C}$
T_{TR_HS}	High-side thermal reset temperature		135			$^{\circ}\text{C}$
T_{HYST_HS}	High-side thermal hysteresis ($T_{SD_HS} - T_{R_HS}$)			7		$^{\circ}\text{C}$
T_{TSD_LS}	Low-side thermal shutdown temperature	$IN_x = 0\text{ V}$	150	175	200	$^{\circ}\text{C}$
V_{CL}	Total clamp voltage (V_{CC} to GND)	$I_{OUT} = 100\text{ mA}$; $t_{clamp} = 1\text{ ms}$	38	46	52	V
V_{OL}	OFF-state open-load voltage detection threshold	$IN_A = IN_B = 0\text{ V}$; PWM = 0; $V_{SELO} = 5\text{ V}$ for CHA; $V_{SELO} = 0\text{ V}$ and within t_{d_stby} for CHB	2	3	4	V
$I_{L(off2)}$	OFF-state output sink current	$IN_A = IN_B = 0$; $V_{OUT} = V_{OL}$; PWM = 0 V; $V_{SELO} = 5\text{ V}$ for CHA; $V_{SELO} = 0\text{ V}$ and within t_{d_stby} for CHB	-100		-15	μA
t_{DSTKON}	OFF-state diagnostic delay time from falling edge of INPUT (see Figure 4)	$IN_A = 5\text{ V}$ to 0 V ; $IN_B = 0$; $V_{SELO} = 5\text{ V}$; PWM = 0; $I_{OUT} = 0\text{ A}$; $V_{OUTA} = 4\text{ V}$	40	140	300	μs

Table 9. Protections and diagnostics ($V_{CC} = 7\text{ V}$ up to 18 V ; $-40\text{ }^\circ\text{C} < T_j < 150\text{ }^\circ\text{C}$)

Symbol	Parameter	Test conditions	Min.	Typ.	Max.	Unit
t_{D_VOL}	OFF-state diagnostic delay time from rising edge of V_{OUT} (see Figure 11)	$I_{NA} = I_{NB} = 0\text{ V}$; $PWM = 0$; $V_{OUTx} = 0\text{ V}$ to 4 V ; $V_{SELO} = 5\text{ V}$ for CHA; $V_{SELO} = 0\text{ V}$ and within t_{d_stby} for CHB		5	30	μs
$t_{LATCH_RST_HS}^{(1)}$	Input reset time for high side fault unlatch (see Figure 9)	$V_{INx} = 5\text{ V}$ to 0 V ; HSDx faulting	3	10	20	μs
$t_{LATCH_RST_LS}^{(1)}$	Input reset time for low side fault unlatch (see Figure 10)	$V_{INx} = 0\text{ V}$ to 5 V ; LSDx faulting	3	10	20	μs

1. Parameter guaranteed by design and characterization; not subjected to production test.

Table 10. CS ($7\text{ V} < V_{CC} < 18\text{ V}$)

Symbol	Parameter	Test conditions	Min.	Typ.	Max.	Unit
V_{SENSE_CL}	Multisense clamp voltage	$V_{CC} = 18\text{ V}$; $I_{SENSE} = -5\text{ mA}$		11		
		$V_{CC} = 18\text{ V}$; $I_{SENSE} = 5\text{ mA}$	-13		-9	V
K_0	I_{OUT}/I_{SENSE}	$I_{OUT} = 0.05\text{ A}$; $V_{SENSE} = 0.5\text{ V}$; $T_j = -40\text{ }^\circ\text{C}$ to $150\text{ }^\circ\text{C}$	665			
K_1	I_{OUT}/I_{SENSE}	$I_{OUT} = 0.2\text{ A}$; $V_{SENSE} = 0.5\text{ V}$; $T_j = -40\text{ }^\circ\text{C}$ to $150\text{ }^\circ\text{C}$	1083	1900	2716	
K_2	I_{OUT}/I_{SENSE}	$I_{OUT} = 3.5\text{ A}$; $V_{SENSE} = 4\text{ V}$; $T_j = -40\text{ }^\circ\text{C}$ to $150\text{ }^\circ\text{C}$	1315	1540	1779	
K_3	I_{OUT}/I_{SENSE}	$I_{OUT} = 5.5\text{ A}$; $V_{SENSE} = 4\text{ V}$; $T_j = -40\text{ }^\circ\text{C}$ to $150\text{ }^\circ\text{C}$	1357	1540	1727	
$dK_0/K_0^{(1)(2)}$	Analog sense current drift	$I_{OUT} = 0.05\text{ A}$; $V_{SENSE} = 0.5\text{ V}$; $T_j = -40\text{ }^\circ\text{C}$ to $150\text{ }^\circ\text{C}$	-25		25	%
$dK_1/K_1^{(1)(2)}$	Analog sense current drift	$I_{OUT} = 0.2\text{ A}$; $V_{SENSE} = 0.5\text{ V}$; $T_j = -40\text{ }^\circ\text{C}$ to $150\text{ }^\circ\text{C}$	-21		21	%
$dK_2/K_2^{(1)(2)}$	Analog sense current drift	$I_{OUT} = 3.5\text{ A}$; $V_{SENSE} = 4\text{ V}$; $T_j = -40\text{ }^\circ\text{C}$ to $150\text{ }^\circ\text{C}$	-5		5	%
$dK_3/K_3^{(1)(2)}$	Analog sense current drift	$I_{OUT} = 5.5\text{ A}$; $V_{SENSE} = 4\text{ V}$; $T_j = -40\text{ }^\circ\text{C}$ to $150\text{ }^\circ\text{C}$	-4		4	%
$V_{SENSESAT}$	Max analog sense output voltage	$V_{CC} = 7$; $R_{SENSE} = 10\text{ k}\Omega$; $V_{SELO} = 5\text{ V}$; $I_{OUTA} = 5.5\text{ A}$; $V_{INA} = 5\text{ V}$; $PWM = 0$; $T_j = 150\text{ }^\circ\text{C}$	5			V
I_{SENSE_SAT}	CurrentSense saturation current	$V_{CC} = 13\text{ V}$; $V_{INA} = 5\text{ V}$; $V_{INB} = 0\text{ V}$; $V_{SENSE} = 4\text{ V}$; $V_{SELO} = 5\text{ V}$; $T_j = 150\text{ }^\circ\text{C}$	4.6			mA
$I_{OUT_SAT}^{(2)}$	Output saturation current	$V_{CC} = 13\text{ V}$; $V_{SENSE} = 4\text{ V}$; $V_{INA} = 5\text{ V}$; $V_{INB} = 0\text{ V}$; $V_{SELO} = 5\text{ V}$; $T_j = 150\text{ }^\circ\text{C}$	8			A

Table 10. CS (7 V < V_{CC} < 18 V) (continued)

Symbol	Parameter	Test conditions	Min.	Typ.	Max.	Unit
V _{OUT_MSD} ⁽²⁾	Output Voltage for MultiSense shutdown	V _{INA} = 5 V; V _{INB} = 0 V; V _{SEL0} = 5 V; R _{SENSE} = 2.7 kΩ; I _{OUT} = 3.5 A		5		V
I _{SENSE0}	CS leakage current	I _{OUT} = 0 A; V _{SENSE} = 0 V; I _{N_x} = 0 V; SEL ₀ = 0; T _j = -40°C to 150°C (Standby)	0		0.5	μA
		I _{OUT} = 0 A; V _{SENSE} = 0 V; I _{N_x} = 0 V; SEL ₀ = 5 V; T _j = -40°C to 150°C (No Standby)	0		0.5	μA
		I _{N_x} = 5 V; PWM = 5 V; I _{OUT} = 0 A; T _j = -40°C to 150°C	0		5	μA
V _{SENSEH}	CS output voltage in fault condition	V _{CC} = 13 V; R _{SENSE} = 1 kΩ; – E.g. Out _A in open-load: V _{INA} = 0 V; I _{OUTA} = 0 A; V _{OUTA} = 4 V; V _{SEL0} = 5 V	5		7	V
I _{SENSEH}	CS output current in fault condition	V _{CC} = 13 V; V _{SENSE} = V _{SENSEH}	7	20	30	mA

1. Analog sense current drift is deviation of factor K for a given device over (-40 °C to 150 °C and 9 V < V_{CC} < 18 V) with respect to its value measured at T_j = 25 °C, V_{CC} = 13 V.
2. Parameter guaranteed by design and characterization; not subjected to production test.

Figure 4. T_{DSTKON}

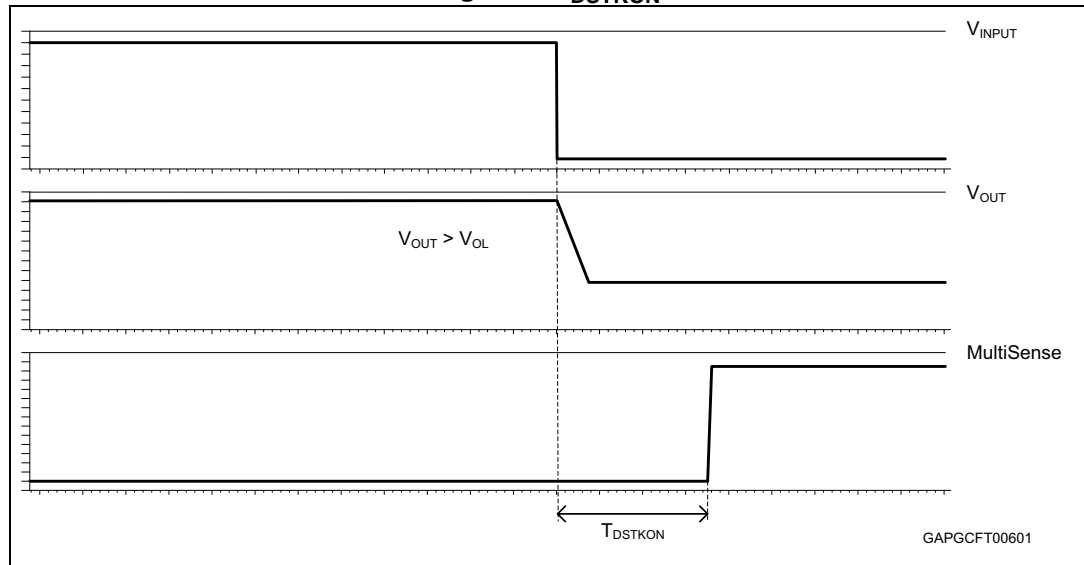

Figure 5. Definition of the low-side switching times

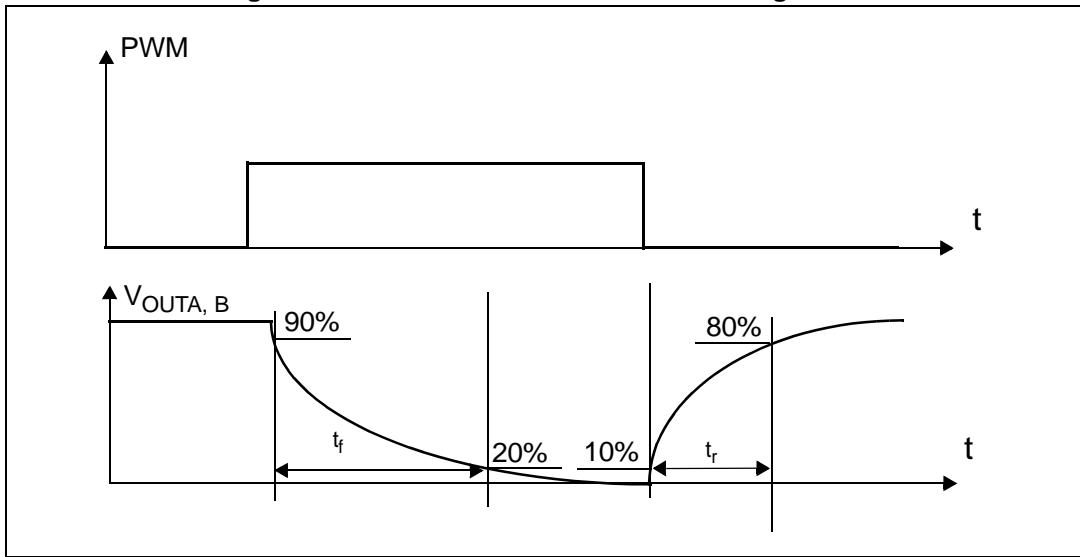

Figure 6. Definition of the high-side switching times

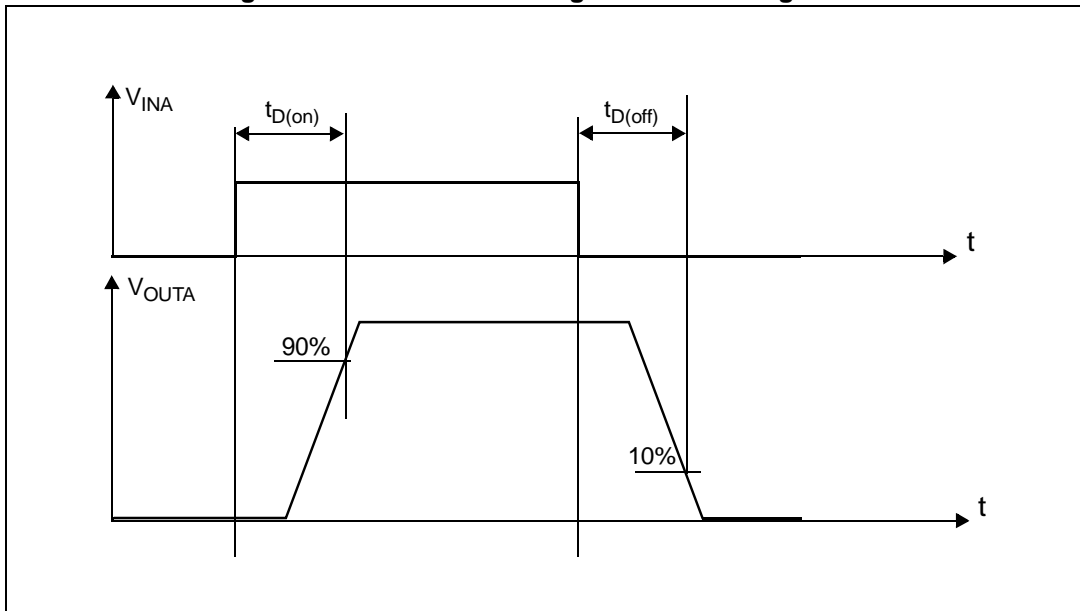

Figure 7. Low-side turn-on delay time

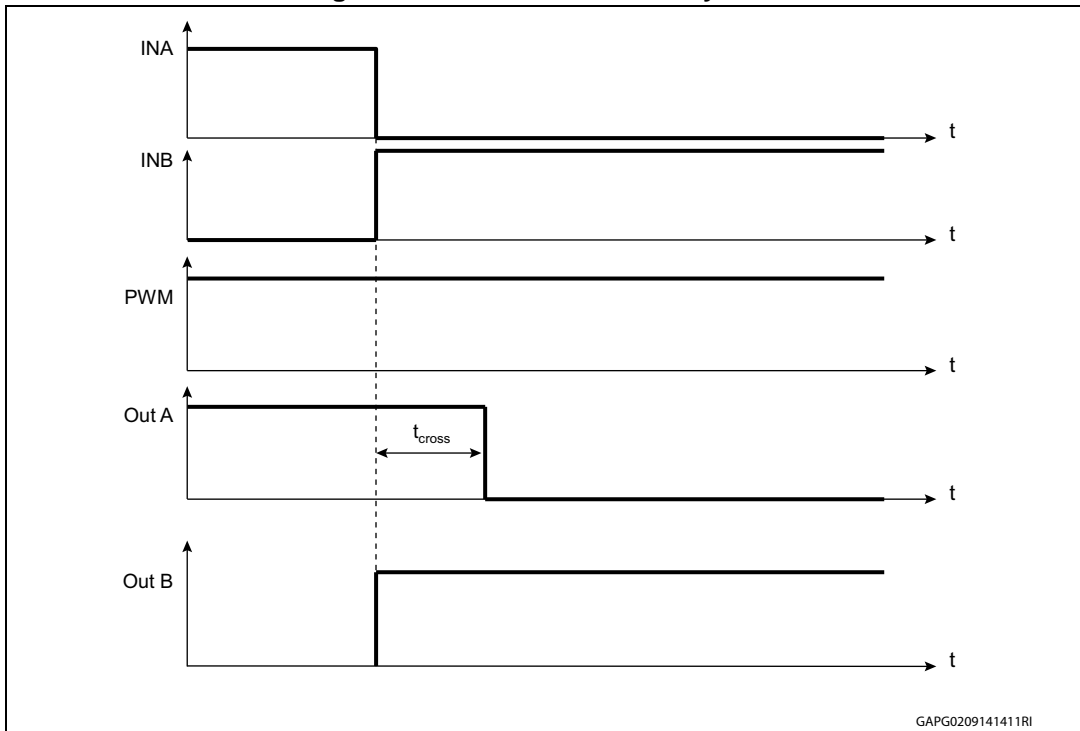

Figure 8. Time to shutdown for the low-side driver

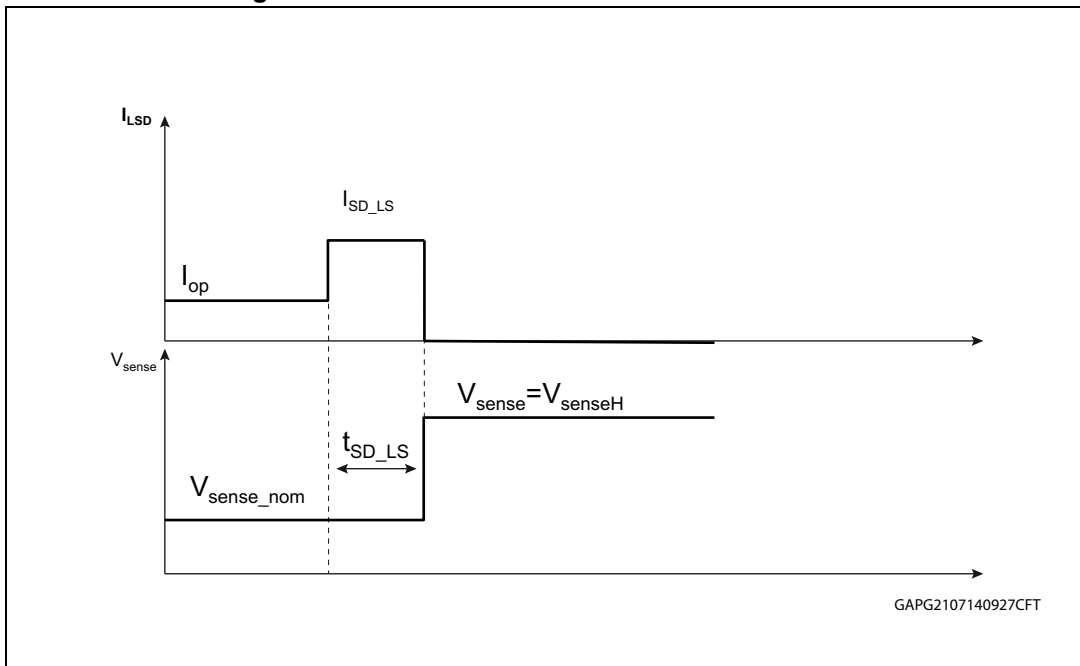

Figure 9. Input reset time for HSD - fault unlatch

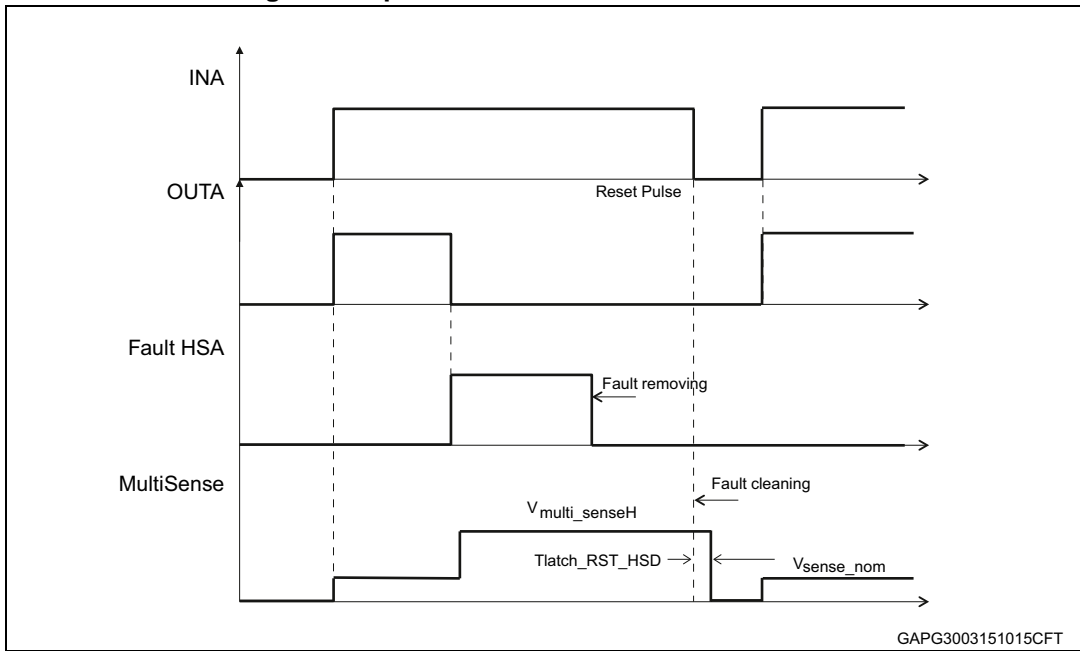

Figure 10. Input reset time for LSD - fault unlatch

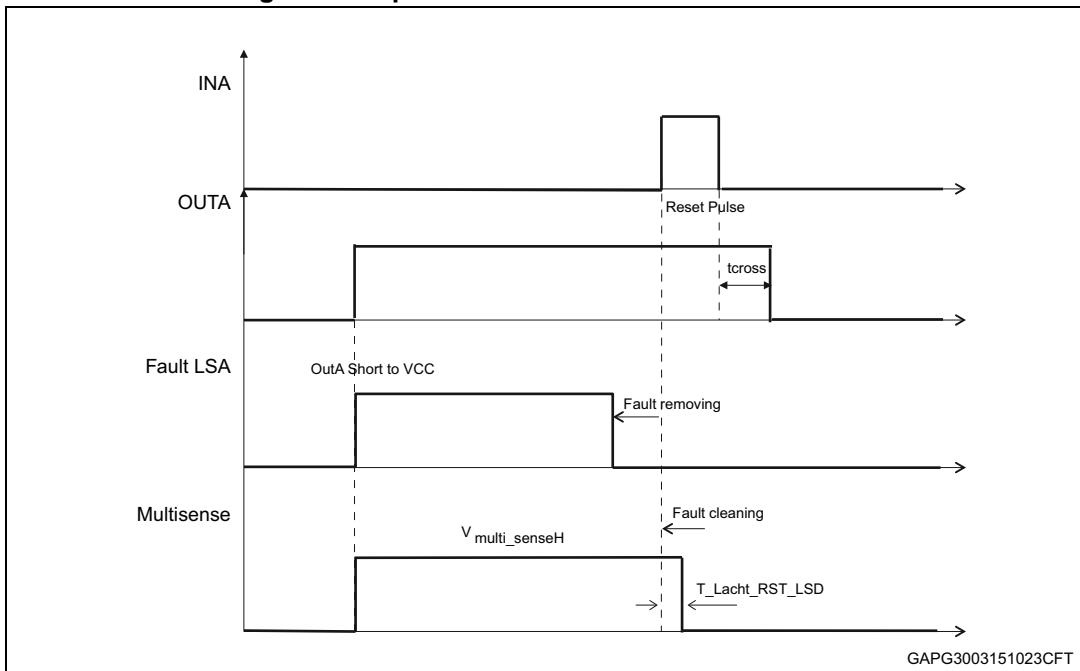

Figure 11. OFF-state diagnostic delay time from rising edge of V_{OUT} (t_{D_VOL})

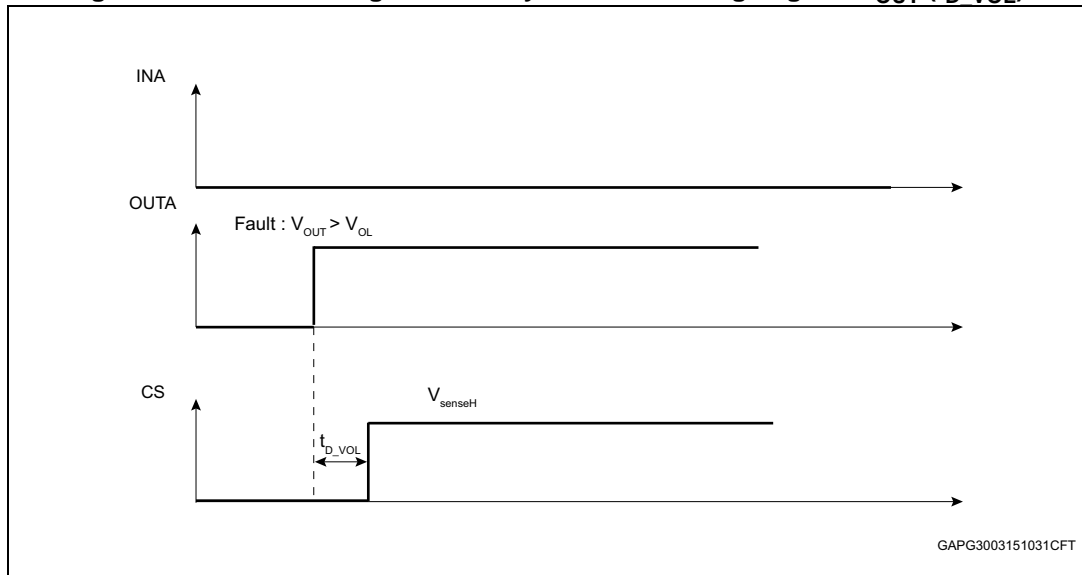

Table 11. Operative condition - truth table

Pin status					HSDs and LDSs status			
IN _A	IN _B	SEL ₀	PWM	CS	HSDA	LSDA	HSDB	LSDB
1	1	1	x	Current Monitoring HSDA	On	Off	On	Off
		0		Current Monitoring HSDB				
1	0	1	1	Current Monitoring HSDA	On	Off	Off	On
			0		On	Off	Off	Off
1	0	0	1	Hi-Z	On	Off	Off	On
			0		On	Off	Off	Off
0	1	1	1	Hi-Z	Off	On	On	Off
			0		Off	Off	On	Off
0	1	0	1	Current Monitoring HSDB	Off	On	On	Off
			0		Off	Off	On	Off
0	0	1	1	Hi-Z	Off	On	Off	On
		0						
0	0	1	0	x ⁽¹⁾	Off	Off	Off	Off
		0 ⁽²⁾						

1. Refer to [Table 13: Off-state -truth table](#)
2. For IN_A = IN_B = SEL₀ = PWM = 0, the device enters in standby after T_{D_sdb}y

Table 12. On-state fault conditions- truth table Fault on leg A (preliminary)

IN _A	IN _B	SEL ₀	PWM	Out _A	Out _B	CS	Fault description
On state diagnostic							
1	0	1	X	L	L	V _{SENSEH}	Out A short to GND
1	0	0	1	H	H	V _{SENSEH}	Out B short to V _{CC}
0	1	1	1	H	H	V _{SENSEH}	Out A short to V _{CC}
0	1	0	X	X	L	V _{SENSEH}	Out B short to GND

Table 13. Off-state -truth table

IN _A	IN _B	SEL ₀	PWM	Out _A	Out _B	CS	Description
Off-state diagnostic							
0	0	1	0	$V_{outA} > V_{OL}$	x	V_{SENSEH}	Case 1. Out _A shorted to V _{CC} if no pull-up is applied Case 2. No open-load in full bridge configuration with an external pull-up on Out _B Case 3. open-load in half bridge configuration with an external pull-up on Out _A (motor connected between Out _A and Ground)
				$V_{outA} < V_{OL}$	x	Hi-Z	Case 1. Open-load in full Bridge configuration with an external pull-up on Out _B Case 2. No open-load in half Bridge configuration with external pull-up on Out _A (motor connected between Out _A and Ground)
	0 ⁽¹⁾⁽²⁾	X		$V_{outB} > V_{OL}$	V_{SENSEH}	Case 1. Out _B shorted to V _{CC} if no pull-up is applied Case 2. No open-load in full bridge configuration with external pull-up on Out _A Case 3. Open-load in half bridge configuration with external pull-up on Out _B (motor connected between Out _B and Ground)	
		X		$V_{outB} < V_{OL}$	Hi-Z	Case1. Open-load in full Bridge configuration with an external pull-up on Out _A Case 2. No open-load in half Bridge configuration with external pull-up on Out _B (motor connected between Out _B and Ground)	

1. The device enters standby mode after T_{D_sdbdy}
2. To power on the device from the standby, it is recommended to toggle INA or INB from 0 to 1 first and then PWM from 0 to 1 to avoid any over-stress on the device in case of short-to-battery.

2.4 Waveforms

Figure 12. Normal operative conditions

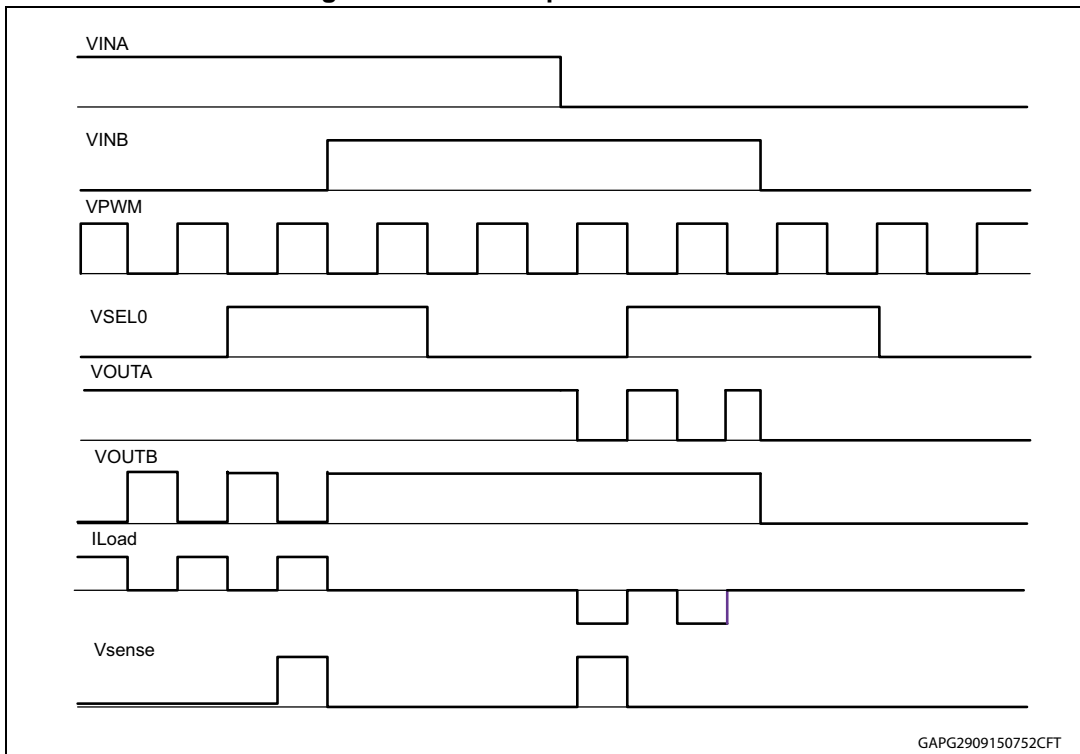

Figure 13. OUT shorted to ground and short clearing

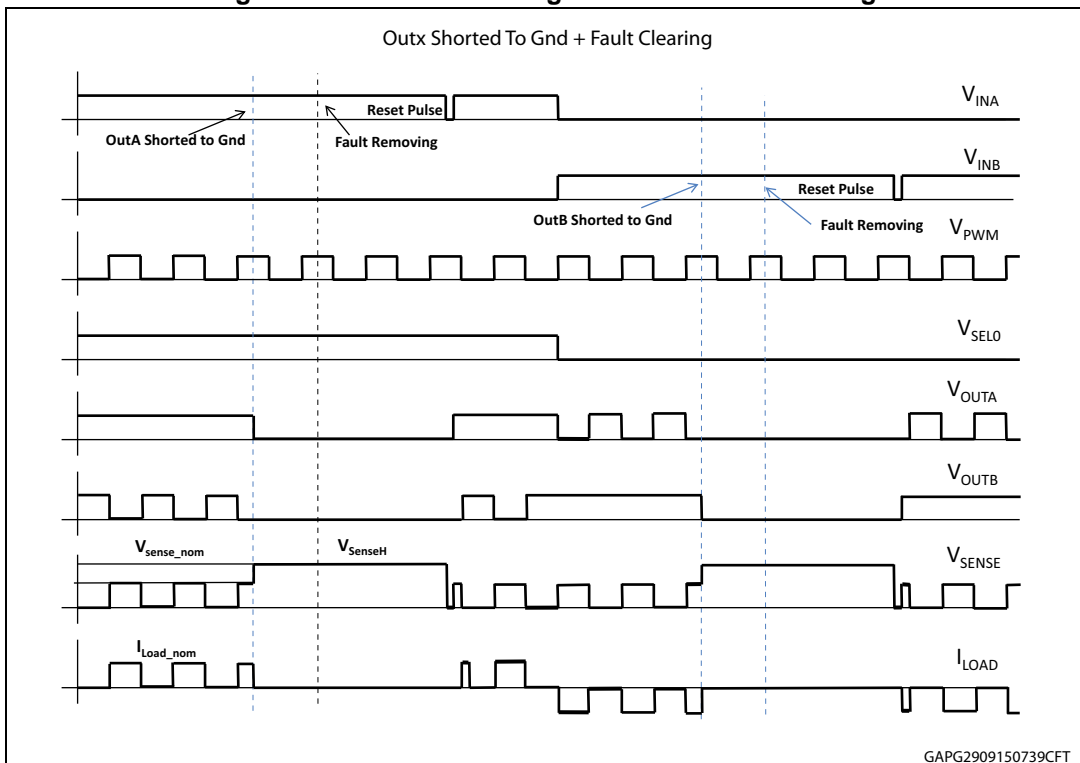

Figure 14. OUT shorted to Vcc and short clearing

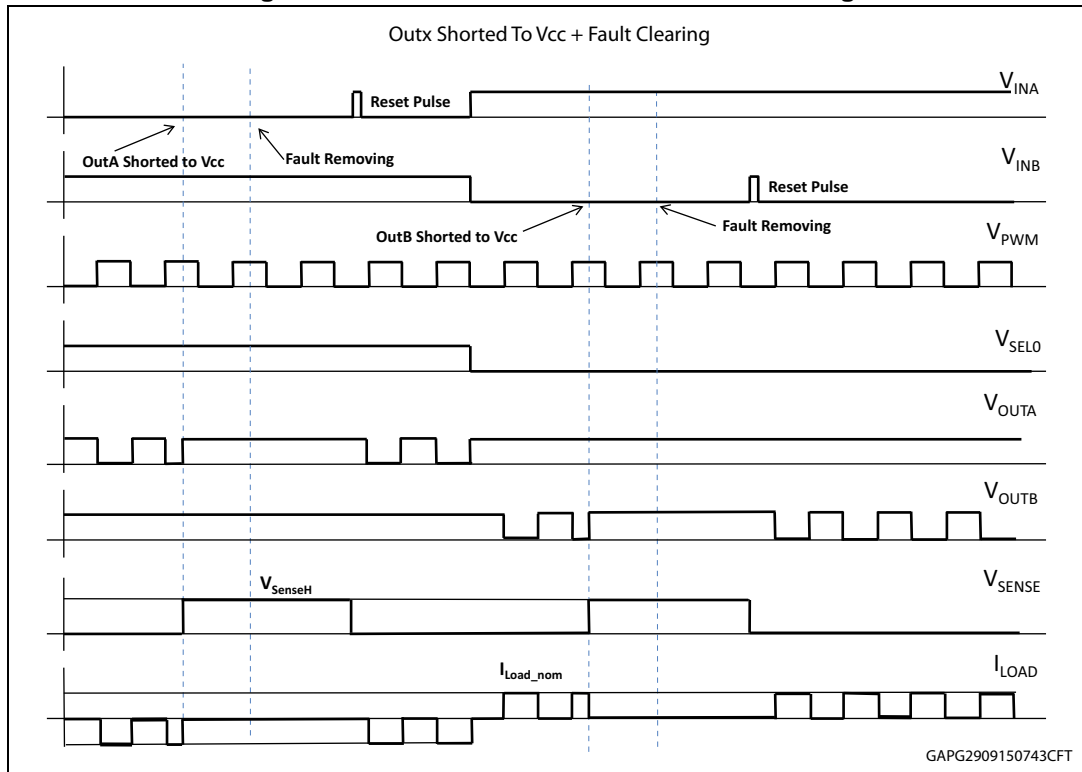
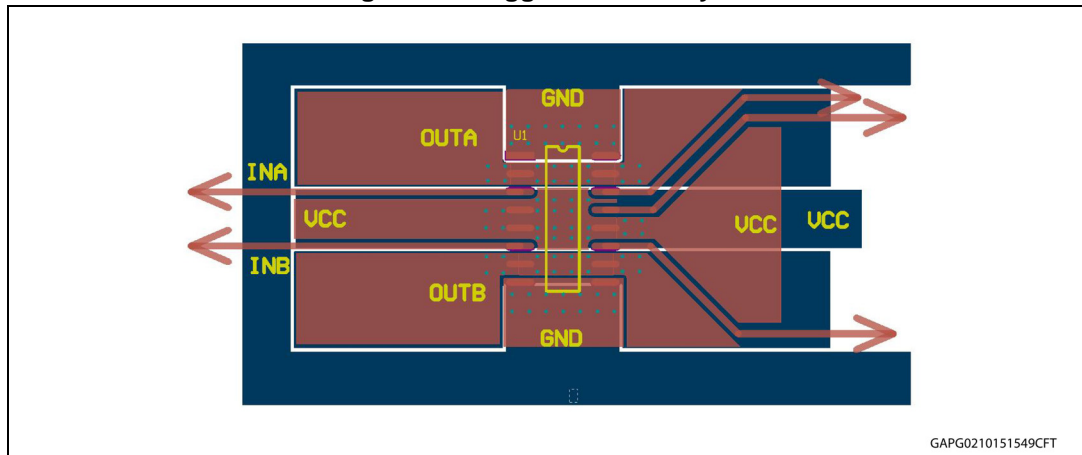

Figure 17. Suggested PCB layout



Note: PCB layout recommendation:
 Optimized connection (short) between Drain LSD and Source HSD
 Optimized GNDa and GNDb connection (symmetric connection)

3.1 Reverse battery protection

Three possible solutions can be considered:

- A Schottky diode D connected to V_{CC} pin
- An N-channel MOSFET connected to the GND pin
- A P-channel MOSFET connected to the V_{CC} pin

In case the reverse battery protection is not present, the device sustains no more than -15 A because of the two Body diodes of the Power MOSFETs. Additionally, in reverse battery condition the I/Os of the device is pulled down to the V_{CC} line (approximately -1.5 V).

Series resistor must be inserted to limit the current sunk from the microcontroller I/Os. If I_{Rmax} is the maximum target reverse current through microcontroller I/Os, series resistor is:

$$R = \frac{V_{IOs} - V_{CC}}{I_{Rmax}}$$

3.2 OFF-state open-load detection – External circuitry dimensioning

The detection of an open-load in off state requires an external circuitry to be connected between Output and V_{BATT}.

For the detection it is necessary to put one network on each leg in case of Half Bridge operation or one network on one of the output in case of full bridge (see [Table 13: Off-state -truth table](#)).

The external circuitry is made up by an external pull-up resistor R_{pull_up} connecting the output to a positive supply voltage V_{PU} (V_{Batt}).

It is preferable to switch-off V_{PU} by using an external pull_up switch to reduce the overall standby current during the module standby mode.

R_{pull_up} must be dimensioned to ensure that in normal operative conditions $V_{OUT} > V_{OLmax}$.

To satisfy this condition the R_{pull_up} must be selected according to:

- if the device is used in half bridge configuration, the equation is:

$$R_{pull_up} < \frac{V_{BATTmin} - V_{OLmax}}{I_{L(off2)min}[@VOLmax]}$$

- if the device is used in H-bridge configuration, the equation is:

$$R_{pull_up} < \frac{V_{BATTmin} - V_{OLmax}}{2 \times I_{L(off2)min}[@VOLmax]}$$

3.3 Immunity against transient electrical disturbances

The immunity of the device against transient electrical emissions, conducted along the supply lines and injected into the V_{CC} pin, is tested in accordance with ISO7637-2:2011 (E) and ISO 16750-2:2010.

The related function performance status classification is shown in [Table 14](#).

Test pulses are applied directly to DUT (Device Under Test) both in ON and OFF-state and in accordance to ISO 7637-2:2011(E), chapter 4. The DUT is intended as the present device only, without components and accessed through V_{CC} and GND terminals.

Status II is defined in ISO 7637-1 Function Performance Status Classification (FPSC) as follows: "The function does not perform as designed during the test but returns automatically to normal operation after the test".

Table 14. ISO 7637-2 - electrical transient conduction along supply line

Test Pulse 2011(E)	Test pulse severity level with Status II functional performance status		Minimum number of pulses or test time	Burst cycle / pulse repetition time		Pulse duration and pulse generator internal impedance
	Level	$U_S^{(1)}$		min	max	
1	III	-112 V	500 pulses	0,5 s		2ms, 10 Ω
2a	III	+55 V	500 pulses	0,2 s	5 s	50 μ s, 2 Ω
3a	IV	-220 V	1h	90 ms	100 ms	0.1 μ s, 50 Ω
3b	IV	+150 V	1h	90 ms	100 ms	0.1 μ s, 50 Ω
4 ⁽²⁾	IV	-7 V	1 pulse			100ms, 0.0 1 Ω
Load dump according to ISO 16750-2:2010						
Test B ⁽³⁾		40 V	5 pulse	1 min		400 ms, 2 Ω

1. U_S is the peak amplitude as defined for each test pulse in ISO 7637-2:2011(E), chapter 5.6.

2. Test pulse from ISO 7637-2:2004(E).
3. With 40 V external suppressor referred to ground ($-40^{\circ}\text{C} < T_j < 150^{\circ}\text{C}$).

3.4 Device configurations

Figure 18. Half-bridge configuration (case a)

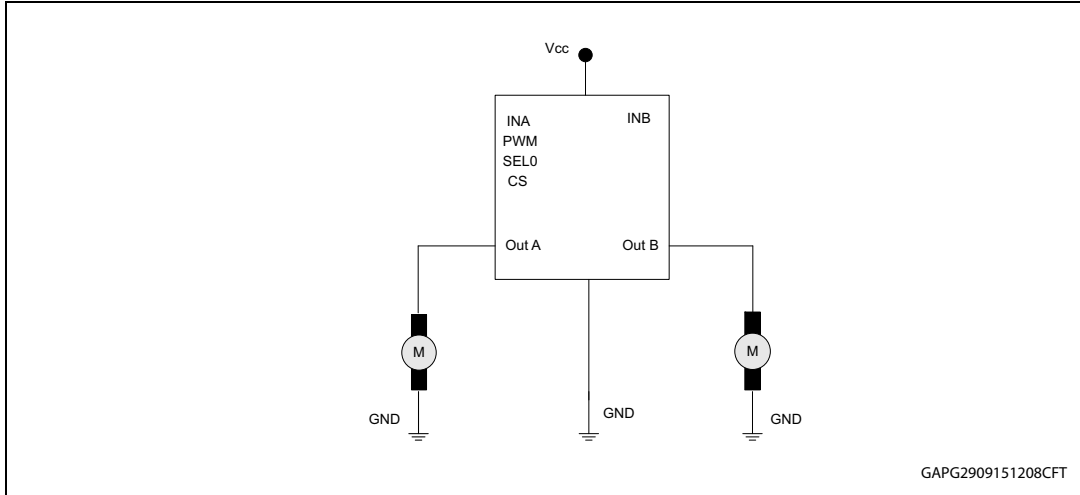

Note: The VNH7070AS can be used in half bridge configuration as the two legs can be independently driven. The SELO pin can be used to address the diagnostic on the CS according to the operative truth table.

Figure 19. Half-bridge configuration (case b)

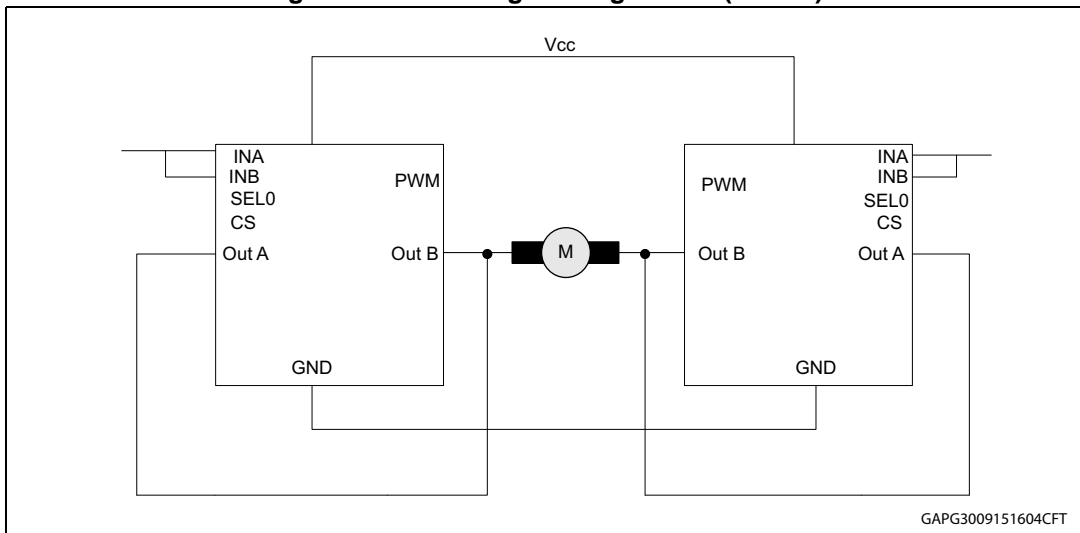

Note: The VNH7070AS can be used in applications where an half-bridge with a resistance of 50 mΩ per leg is needed.

Figure 20. Multi-motors configuration

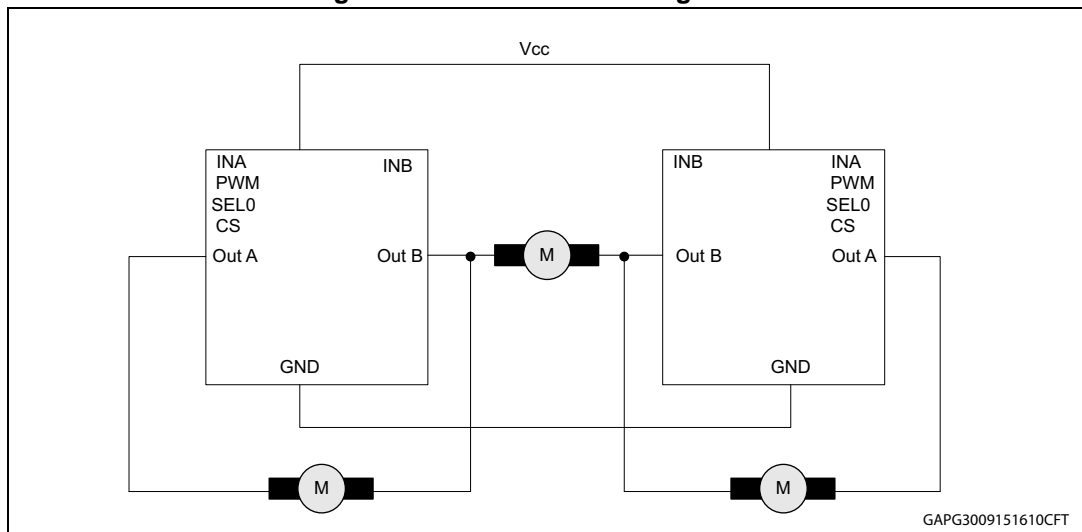

Note: The VNH7070AS can easily be designed in multi motor driving configuration in the applications where only one motor at a time must be activated. The SEL0 pin can be used to read the diagnostic on the CS according to the operative truth table.

4 Package and PCB thermal data

4.1 SO16-N thermal data

Figure 21. PCB layout (top and bottom): footprint, 2+2+2 cm², 8+8+8 cm²

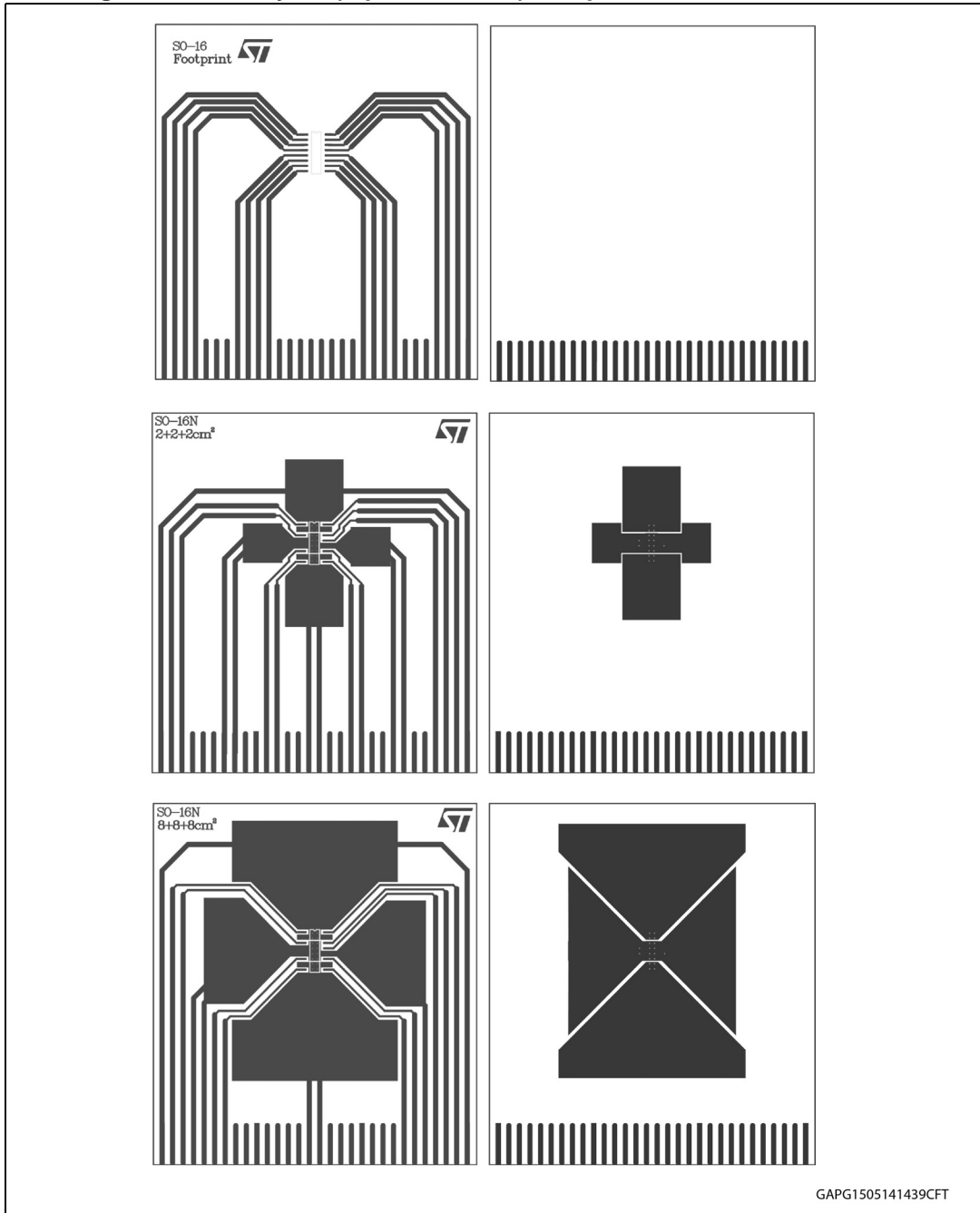
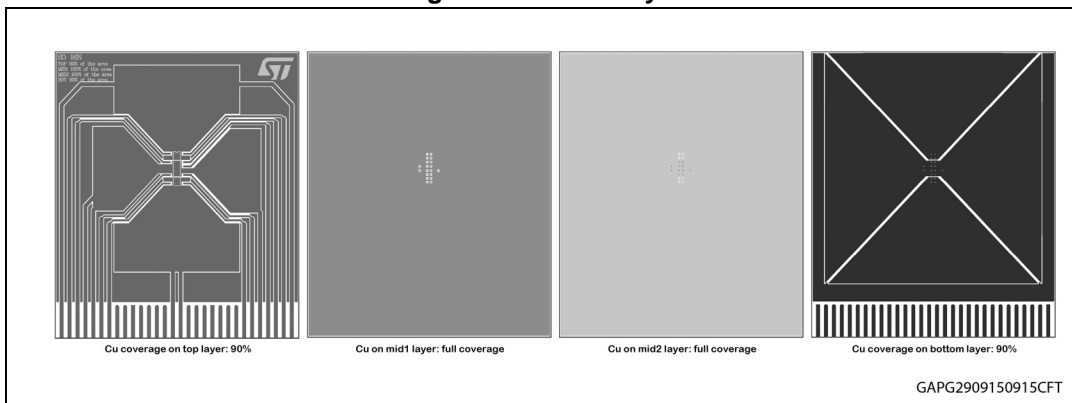

Figure 22. PCB 4 layer



Note: Board finish thickness 1.6 mm +/- 10%; Board double layer and four layers; Board dimension 77x86 mm; Board Material FR4; Cu thickness 0.070mm (outer layers); Cu thickness 0.035mm (inner layers); Thermal via separation 1.2 mm; Thermal via diameter 0.3 mm +/- 0.08 mm; Cu thickness on vias 0.025 mm.

4.2 Package thermal data

4.2.1 Thermal characterization in steady state conditions

Figure 23. Chipset configuration configuration in steady state conditions

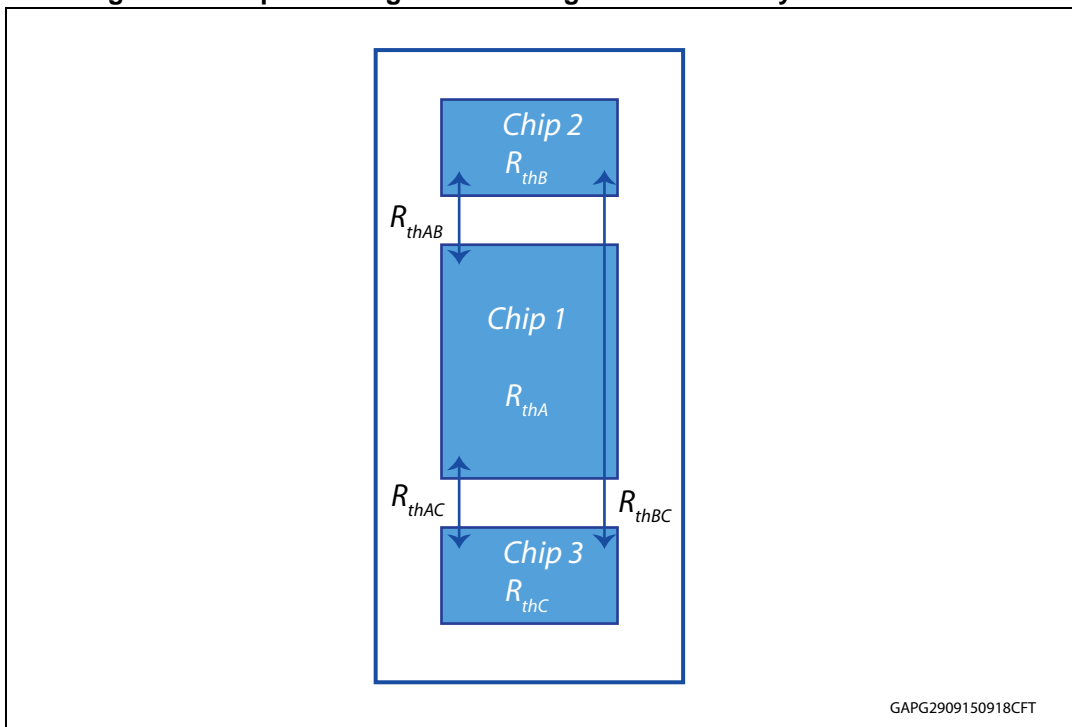

Figure 24. Auto and mutual $R_{thj-amb}$ vs. PCB heat-sink area in open box free air condition

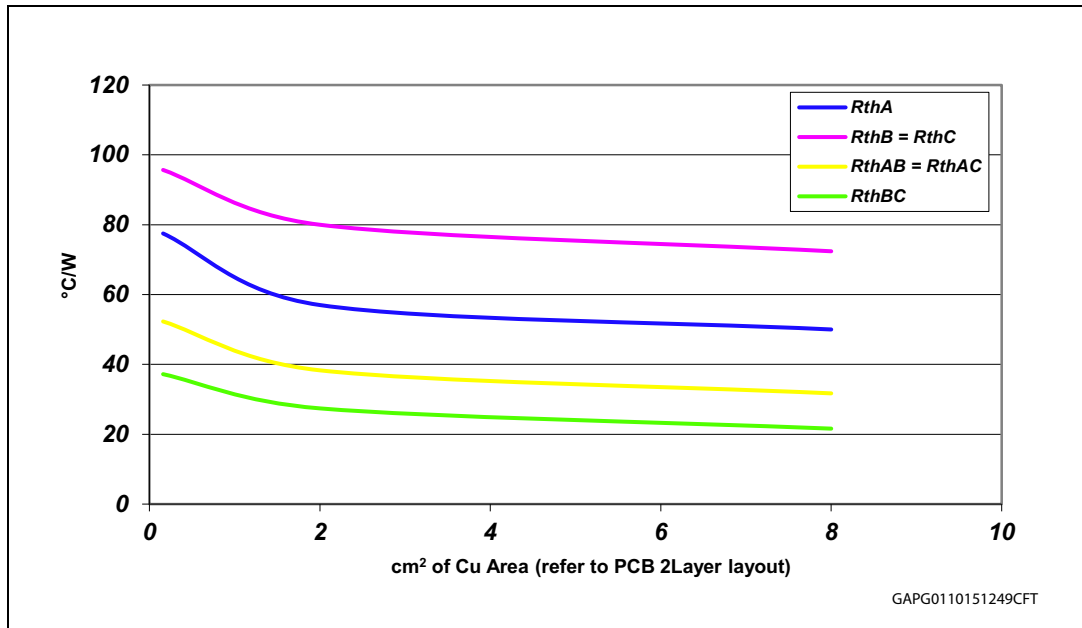

Table 15. Thermal model for junction temperature calculation in steady-state conditions\

Chip 1	Chip 2	Chip 3	Tjchip1	Tjchip2	Tjchip3
ON	OFF	ON	$P_{dchip1} \cdot R_{thA} + P_{dchip3} \cdot R_{thAC} + T_{amb}$	$P_{dchip1} \cdot R_{thAB} + P_{dchip3} \cdot R_{thBC} + T_{amb}$	$P_{dchip1} \cdot R_{thAC} + P_{dchip3} \cdot R_{thC} + T_{amb}$
ON	ON	OFF	$P_{dchip1} \cdot R_{thA} + P_{dchip2} \cdot R_{thAB} + T_{amb}$	$P_{dchip1} \cdot R_{thAB} + P_{dchip2} \cdot R_{thB} + T_{amb}$	$P_{dchip1} \cdot R_{thAC} + P_{dchip2} \cdot R_{thBC} + T_{amb}$
ON	OFF	OFF	$P_{dchip1} \cdot R_{thA} + T_{amb}$	$P_{dchip1} \cdot R_{thAB} + T_{amb}$	$P_{dchip1} \cdot R_{thAC} + T_{amb}$
ON	ON	ON	$P_{dchip1} \cdot R_{thA} + (P_{dchip2} + P_{dchip3}) \cdot R_{thAB} + T_{amb}$	$P_{dchip2} \cdot R_{thB} + P_{dchip1} \cdot R_{thAB} + P_{dchip3} \cdot R_{thBC} + T_{amb}$	$P_{dchip1} \cdot R_{thAB} + P_{dchip2} \cdot R_{thBC} + P_{dchip3} \cdot R_{thC} + T_{amb}$

4.2.2 Thermal characterization during transients

$$T_{hs} = P_{dhs} \cdot Z_{hs} + Z_{hsIs} \cdot (P_{dIsA} + P_{dIsB}) + T_{amb}$$

$$T_{IsA} = P_{dIsA} \cdot Z_{Is} + P_{dhs} \cdot Z_{hsIs} + P_{dIsB} \cdot Z_{IsIs} + T_{amb}$$

$$T_{IsB} = P_{dIsB} \cdot Z_{Is} + P_{dhs} \cdot Z_{hsIs} + P_{dIsA} \cdot Z_{IsIs} + T_{amb}$$

Figure 25. HSD thermal impedance junction ambient single pulse

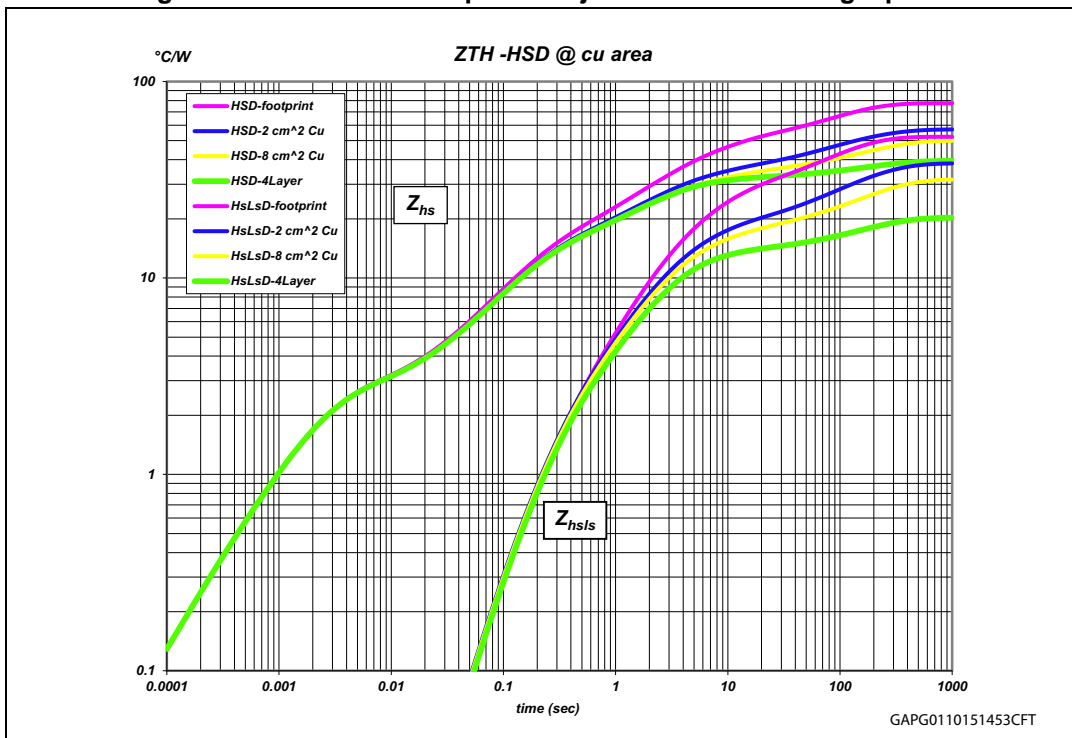

Figure 26. LSD thermal impedance junction ambient single pulse

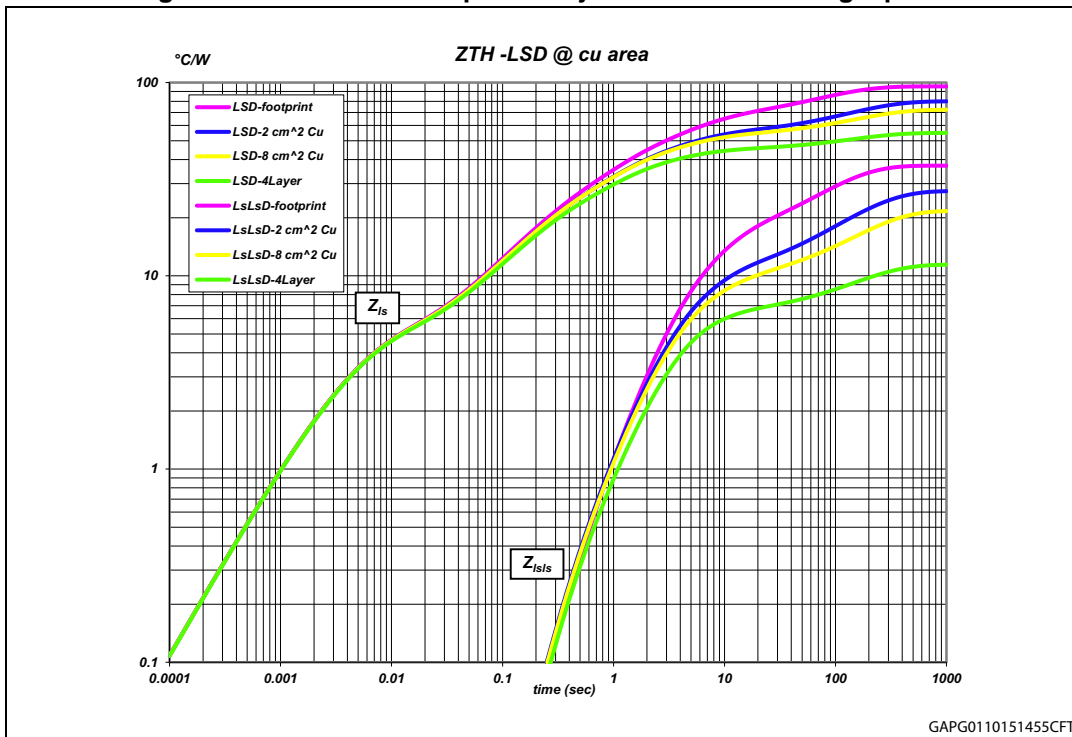

Figure 27. Electrical equivalent model

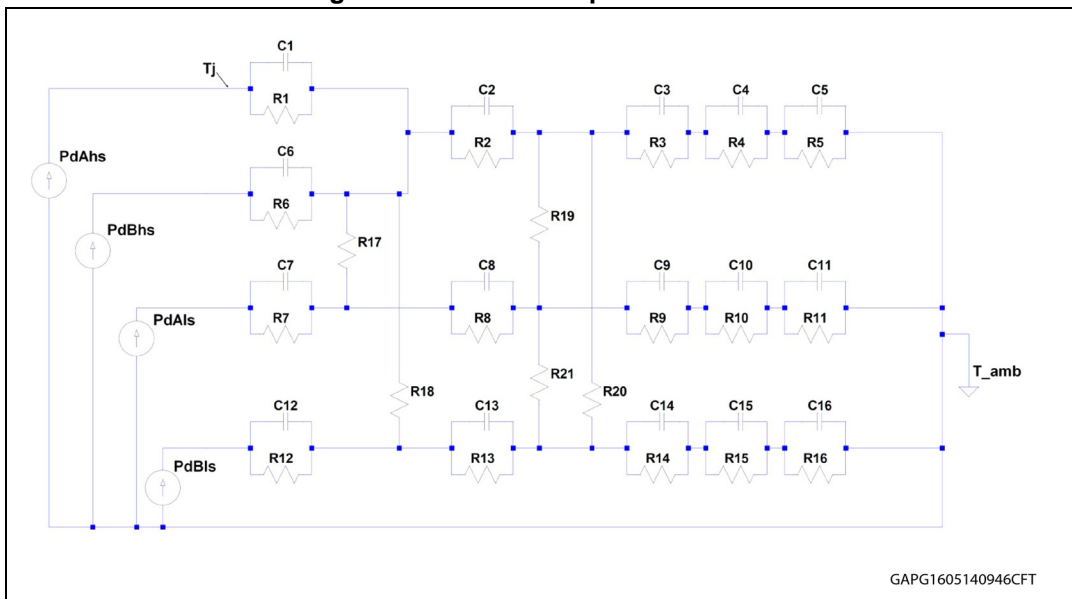

Table 16. Thermal parameters

Area/island (cm ²)	FP	2	8	4L
R1 (°C/W)	2.4	2.4	2.4	2.4
R2 (°C/W)	12	12	12	12
R3 (°C/W)	31	26	26	30
R4 (°C/W)	42	12	12	8
R5 (°C/W)	86	46	31	16
R6 (°C/W)	2.4	2.4	2.4	2.4
R7 (°C/W)	4	4	4	4
R8 (°C/W)	11	11	11	11
R9 (°C/W)	32	32	32	32
R10 (°C/W)	68	52	48	22
R11 (°C/W)	75	80	60	26
R12 (°C/W)	4	4	4	4
R13 (°C/W)	11	11	11	11
R14 (°C/W)	32	32	32	32
R15 (°C/W)	68	52	48	10
R16 (°C/W)	75	80	60	26
R17 (°C/W)	120	100	100	100
R18 (°C/W)	120	100	100	100
R19 (°C/W)	180	170	170	170
R20 (°C/W)	180	170	170	170

Table 16. Thermal parameters (continued)

Area/island (cm ²)	FP	2	8	4L
C1 (W·s/°C)	0.0008	0.0008	0.0008	0.0008
C2 (W·s/°C)	0.015	0.015	0.015	0.015
C3 (W·s/°C)	0.08	0.08	0.08	0.08
C4 (W·s/°C)	0.2	0.5	1	1
C5 (W·s/°C)	1.5	2	6	12
C6 (W·s/°C)	0.0008	0.0008	0.0008	0.0008
C7 (W·s/°C)	0.001	0.001	0.001	0.001
C8 (W·s/°C)	0.015	0.015	0.015	0.015
C9 (W·s/°C)	0.04	0.04	0.04	0.04
C10 (W·s/°C)	0.08	0.1	0.1	0.2
C11 (W·s/°C)	1	2.5	3	6
C12 (W·s/°C)	0.001	0.001	0.001	0.001
C13 (W·s/°C)	0.015	0.015	0.015	0.015
C14 (W·s/°C)	0.04	0.04	0.04	0.04
C15 (W·s/°C)	0.08	0.1	0.1	0.2
C16 (W·s/°C)	1	2.5	3	6

5 Package and packing information

In order to meet environmental requirements, ST offers these devices in different grades of ECOPACK® packages, depending on their level of environmental compliance. ECOPACK® specifications, grade definitions and product status are available at: www.st.com.

ECOPACK® is an ST trademark.

5.1 SO-16N mechanical data

Figure 28. SO-16N package dimensions

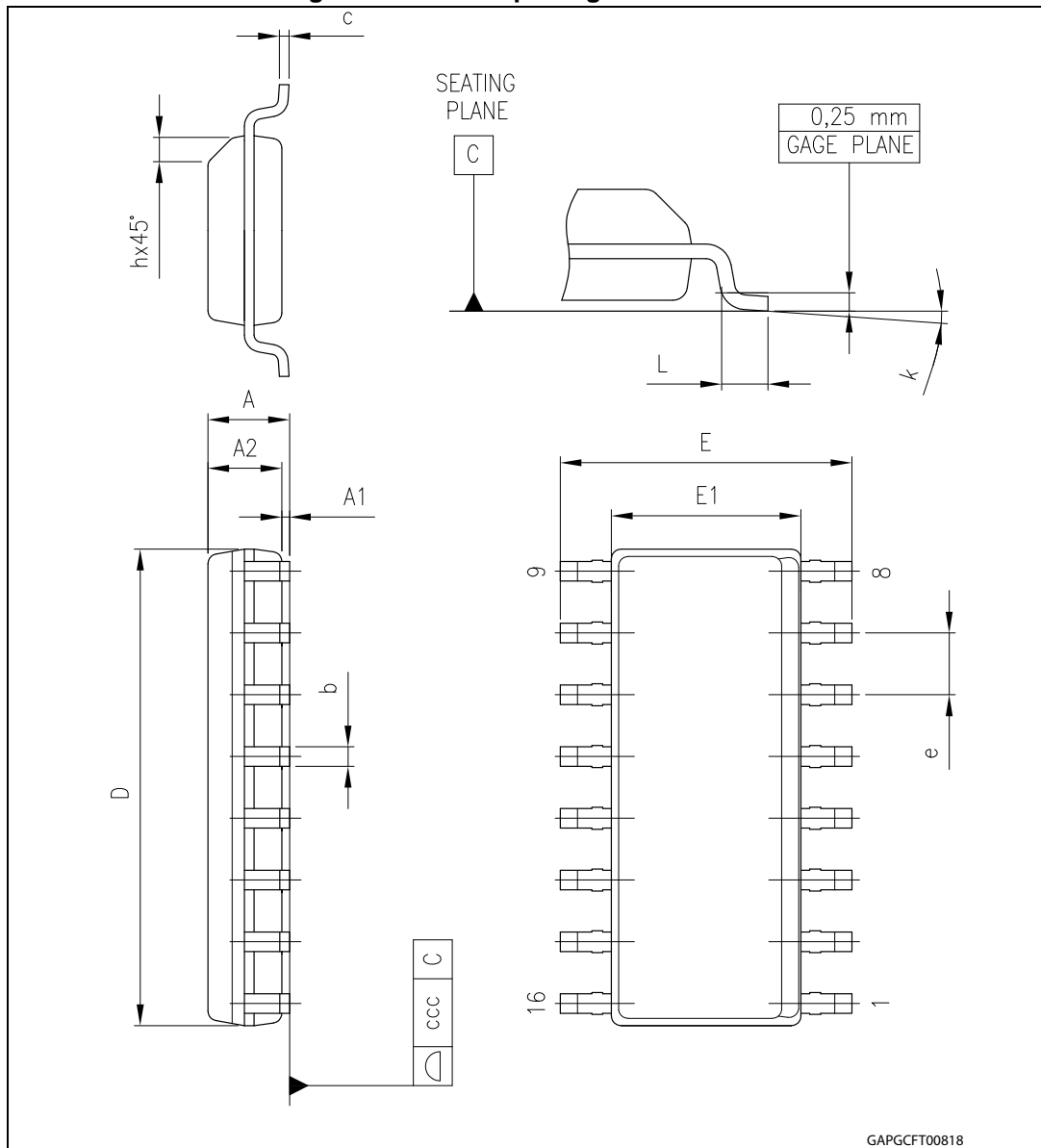

Table 17. SO-16N mechanical data

Symbol	Millimeters		
	Min.	Typ.	Max.
A			1.75
A1	0.10		0.25
A2	1.25		
b	0.31		0.51
c	0.17		0.25
D	9.80	9.90	10.00
E	5.80	6.00	6.20
E1	3.80	3.90	4.00
e		1.27	
h	0.25		0.50
L	0.40		1.27
k	0°		8°
ccc			0.1

5.2 SO-16N packing information

Figure 29. SO-16N reel 13"

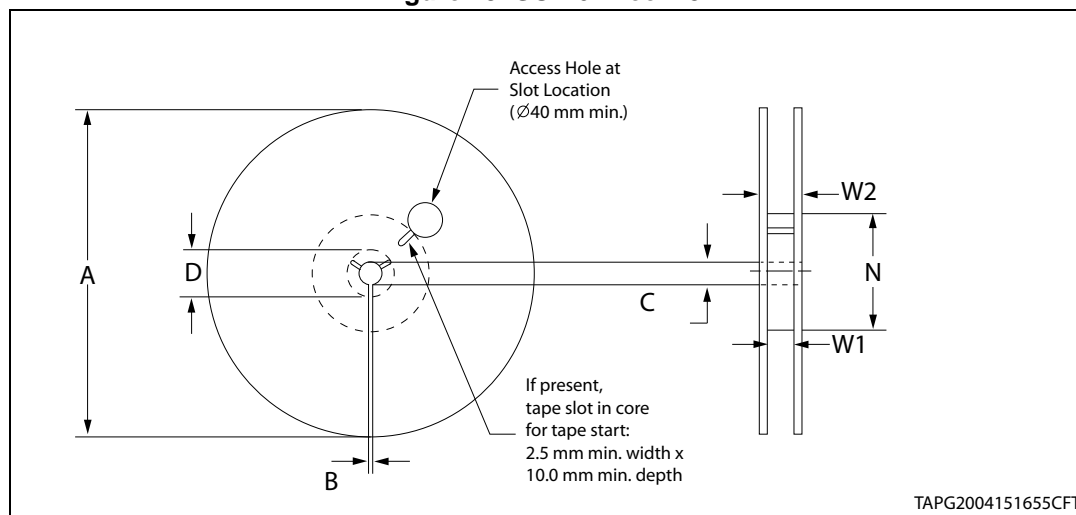

Table 18. Reel dimensions

Description	Value ⁽¹⁾
Base quantity	2500
Bulk quantity	2500
A (max)	330
B (min)	1.5
C (+0.5, -0.2)	13
D (min)	20.2
N	100
W1 (+2 /-0)	16.4
W2 (max)	22.4

1. All dimensions are in mm.

Figure 30. SO-16N rcarrier tape

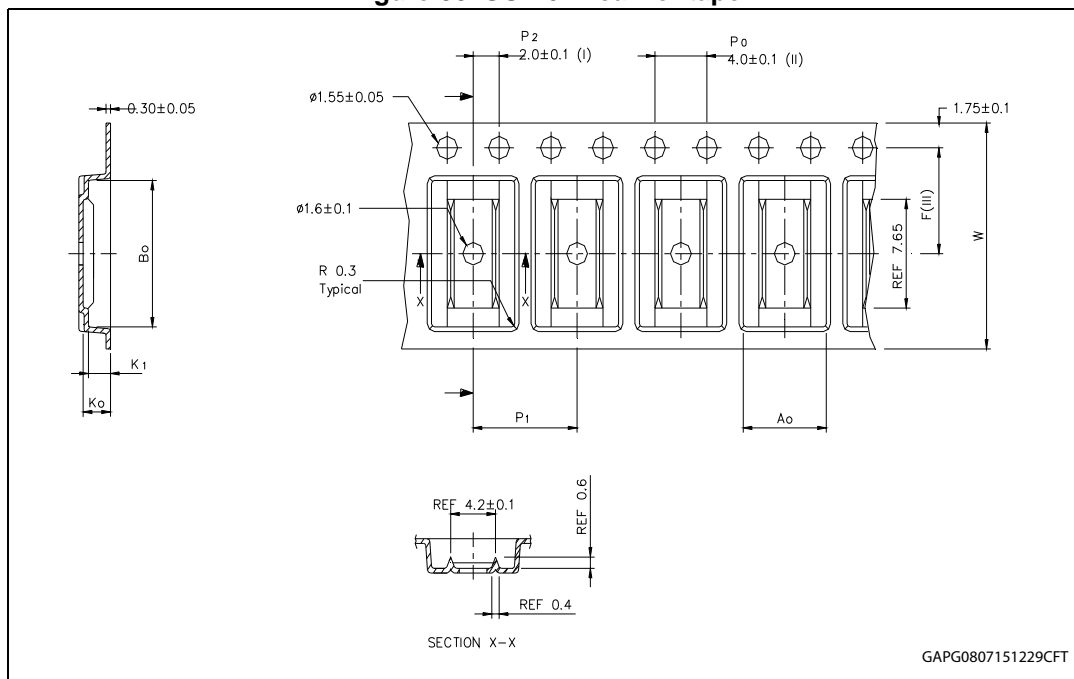

Table 19. SO-16N carrier tape dimensions

Description	Value
A_0	6.55 ± 0.1
B_0	10.38 ± 0.1
K_0	2.10 ± 0.1
K_1	1.80 ± 0.1
F	7.50 ± 0.1

Table 19. SO-16N carrier tape dimensions (continued)

Description	Value
P ₁	8.00 ± 0.1
W	16.00 ± 0.3

Figure 31. SO-16N schematic drawing of leader and trailer tape

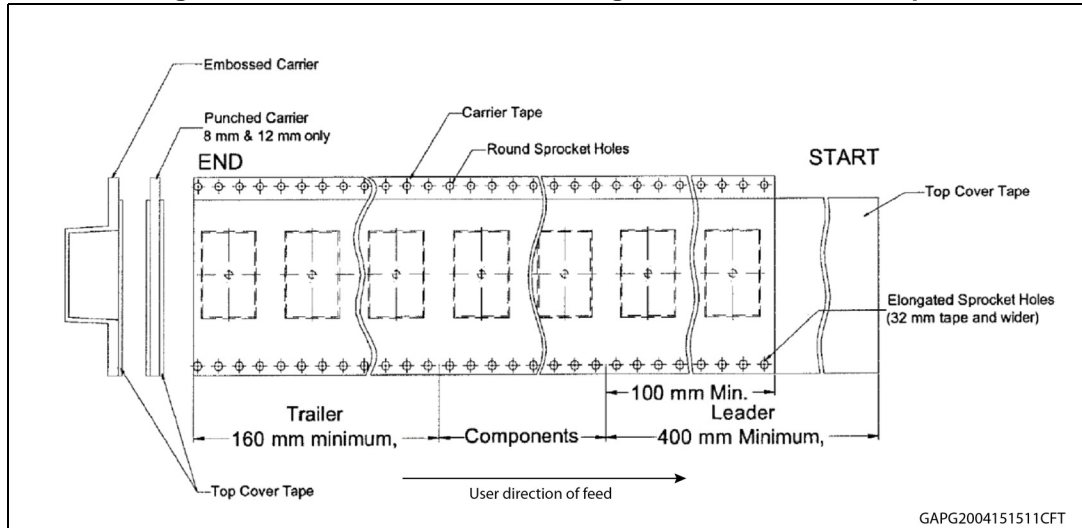

5.3 SO-16N marking information

Figure 32. SO-16N marking information

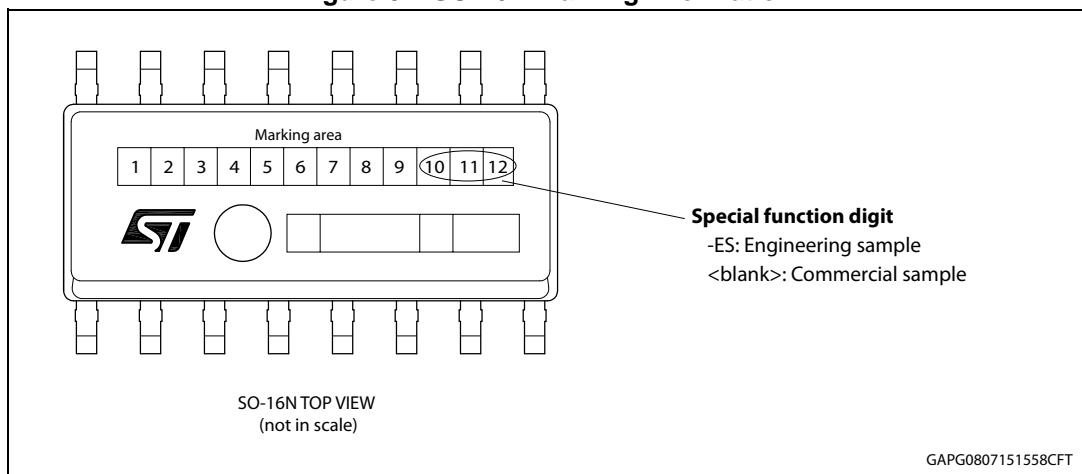

Note: *Engineering Samples: these samples can be clearly identified by a dedicated special symbol in the marking of each unit. These samples are intended to be used for electrical compatibility evaluation only; usage for any other purpose may be agreed only upon written authorization by ST. ST is not liable for any customer usage in production and/or in reliability qualification trials.*

Commercial Samples: fully qualified parts from ST standard production with no usage restrictions.

6 Revision history

Table 20. Document revision history

Date	Revision	Changes
16-Jul-2015	1	Initial release.
06-Oct-2015	2	<p><i>Table 4: Absolute maximum ratings:</i></p> <ul style="list-style-type: none"> - I_{GND}: removed row <p>Updated <i>Table 5: Thermal data</i></p> <p><i>Table 6: Power section:</i></p> <ul style="list-style-type: none"> - V_f: updated parameter <p><i>Table 8: Switching ($V_{CC} = 13\text{ V}$, $R_{LOAD} = 3.7\ \Omega$):</i></p> <ul style="list-style-type: none"> - t_{cross}: updated value <p><i>Table 9: Protections and diagnostics ($V_{CC} = 7\text{ V}$ up to 18 V; $-40\text{ }^\circ\text{C} < T_j < 150\text{ }^\circ\text{C}$):</i></p> <ul style="list-style-type: none"> - t_{DSTKON}: updated value <p><i>Table 10: CS ($7\text{ V} < V_{CC} < 18\text{ V}$):</i></p> <ul style="list-style-type: none"> - K_1, K_2, K_3, I_{SENSE_SAT}, I_{OUT_SAT}: updated values <p>Updated <i>Figure 9: Input reset time for HSD - fault unlatch</i> and <i>Figure 10: Input reset time for LSD - fault unlatch</i></p> <p>Added <i>Section 2.4: Waveforms</i> and Updated <i>Chapter 3: Application information</i></p>
15-Oct-2015	3	<p><i>Table 9: Protections and diagnostics ($V_{CC} = 7\text{ V}$ up to 18 V; $-40\text{ }^\circ\text{C} < T_j < 150\text{ }^\circ\text{C}$):</i></p> <ul style="list-style-type: none"> - V_{CL}: updated test conditions

IMPORTANT NOTICE – PLEASE READ CAREFULLY

STMicroelectronics NV and its subsidiaries ("ST") reserve the right to make changes, corrections, enhancements, modifications, and improvements to ST products and/or to this document at any time without notice. Purchasers should obtain the latest relevant information on ST products before placing orders. ST products are sold pursuant to ST's terms and conditions of sale in place at the time of order acknowledgement.

Purchasers are solely responsible for the choice, selection, and use of ST products and ST assumes no liability for application assistance or the design of Purchasers' products.

No license, express or implied, to any intellectual property right is granted by ST herein.

Resale of ST products with provisions different from the information set forth herein shall void any warranty granted by ST for such product.

ST and the ST logo are trademarks of ST. All other product or service names are the property of their respective owners.

Information in this document supersedes and replaces information previously supplied in any prior versions of this document.

© 2015 STMicroelectronics – All rights reserved