

Octal channel high side driver

Features

Type	$R_{DS(on)}$	I_{out}	V_{CC}
VN808CM-E	160 m Ω	0.7 A	45 V

- CMOS compatible input
- Junction overtemperature protection
- Case overtemperature protection for thermal independence of the channels
- Current limitation
- Shorted load protection
- Undervoltage shutdown
- Protection against loss of ground
- Very low standby current
- Compliance to 61000-4-4 IEC test up to 4 kV

Description

The VN808CM-E is a monolithic device designed in STMicroelectronics VIPower M0-3 technology, intended for driving any kind of load with one side connected to ground. It can be driven by using a 3.3 V logic supply.

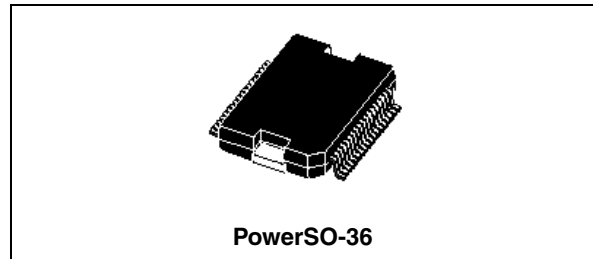

Active current limitation combined with thermal shutdown and automatic restart, protect the device against overload. In overload condition, channel turns OFF and back ON automatically so as to maintain junction temperature between T_{TSD} and T_R . If this condition makes case temperature reach T_{CSD} , overloaded channel is turned OFF and will restart only when case temperature has decreased down to T_{CR} (see waveform 3 [Figure 6 on page 10](#)). Non overloaded channels continue to operate normally. Device automatically turns OFF in case of ground pin disconnection. This device is especially suitable for industrial applications conform to IEC 61131

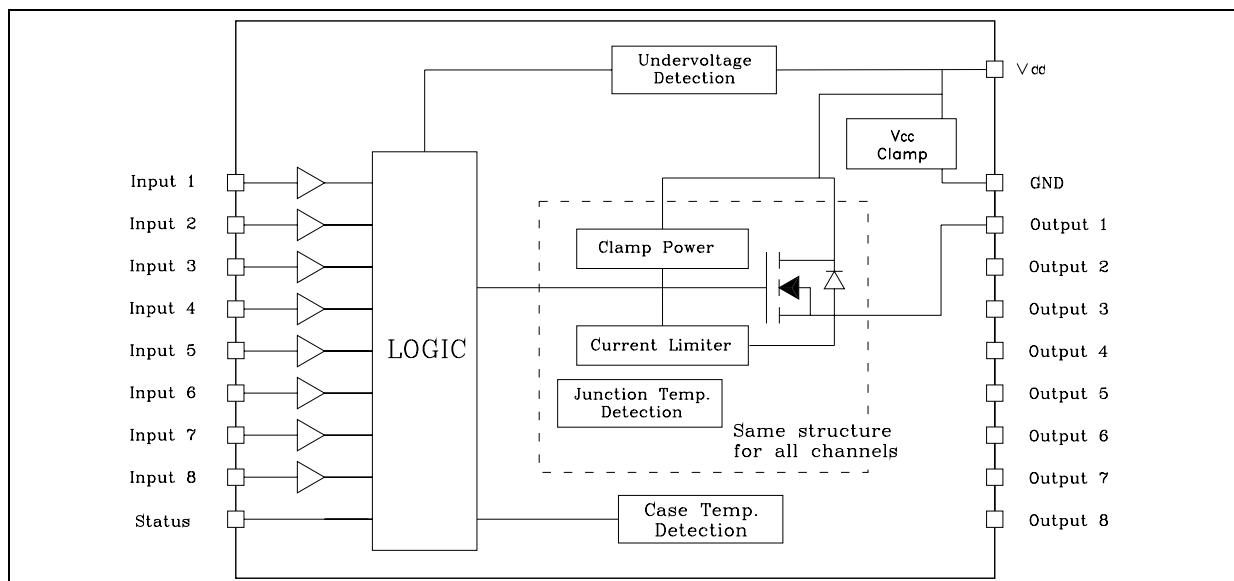

Contents

1	Maximum ratings	3
2	Electrical characteristics	4
3	Pin connections	6
4	Current, voltage conventions and truth table	8
5	Switching time waveforms	9
6	Reverse polarity protection	12
7	Package mechanical data	13
8	Order codes	15
9	Revision history	16

1 Maximum ratings

Table 1. Absolute maximum rating

Symbol	Parameter	Value	Unit
V_{CC}	DC supply voltage	45	V
$-I_{GND}$	DC ground pin reverse current TRAN ground pin reverse current (pulse duration < 1ms)	-250 -6	mA A
I_{OUT}	DC output current	Internally limited	A
$-I_{OUT}$	Reverse DC output current	-2	A
I_{IN}	DC Input current	± 10	mA
V_{ESD}	Electrostatic discharge (R = 1.5 k Ω , C = 100 pF)	2000	V
P_{TOT}	Power dissipation at $T_C = 25\text{ }^\circ\text{C}$	96	W
L_{MAX}	Max inductive load ($V_{CC} = 24\text{ V}$, $R_{LOAD} = 48\text{ }\Omega$, $T_A = 100\text{ }^\circ\text{C}$)	2	H
T_J	Junction operating temperature	Internally limited	$^\circ\text{C}$
T_C	Case operating temperature	Internally limited	$^\circ\text{C}$
T_{STG}	Storage temperature	-40 to 150	$^\circ\text{C}$

Table 2. Thermal data

Symbol	Parameter	Value	Unit
R_{thJC}	Thermal resistance junction-case	Max 1.3	$^\circ\text{C}/\text{W}$
R_{thJA}	Thermal resistance junction-ambient ⁽¹⁾	Max 50	$^\circ\text{C}/\text{W}$

1. When mounted on FR4 printed circuit board with 0.5 cm² of copper area (at least 35 μm thick) connected to all TAB pins.

2 Electrical characteristics

(10.5 V < V_{CC} < 32 V; -40 °C < T_J < 125 °C; unless otherwise specified)

Table 3. Power section

Symbol	Parameter	Test conditions	Min	Typ	Max	Unit
V _{CC}	Operating supply voltage		10.5		45	V
V _{USD}	Undervoltage shutdown		7		10.5	V
R _{ON}	On state resistance	I _{OUT} = 0.5 A; T _J = 25 °C I _{OUT} = 0.5 A;			160 280	mΩ mΩ
I _S	Supply current	OFF state; V _{CC} = 24 V; T _{CASE} = 25 °C ON state (all channels ON); V _{CC} = 24 V, T _{CASE} = 100 °C			150 12	μA mA
I _{LGND}	Output current at turn-off	V _{CC} = V _{STAT} = V _{IN} = V _{GND} = 24 V V _{OUT} = 0 V			1	mA
I _{L(off)}	OFF state output current	V _{IN} = V _{OUT} = 0 V;	0		5	μA
V _{OUT(off)}	OFF state output voltage	V _{IN} = 0 V, I _{OUT} = 0 A			3	V
t _{d(Vccon)}	Power-on delay time from V _{CC} rising edge	<i>Figure 7 on page 12</i>		1		ms

Table 4. Switching (V_{CC} = 24 V)

Symbol	Parameter	Test conditions	Min	Typ	Max	Unit
t _{ON}	Turn-on time	R _L = 48 Ω from 80 % V _{OUT} <i>Figure 4.</i>	-	50	100	μs
t _{OFF}	Turn-off time	R _L = 48 Ω to 10 % V _{OUT} <i>Figure 4.</i>	-	75	150	μs
dV _{OUT} /dt _(on)	Turn-on voltage slope	R _L = 48 Ω from V _{OUT} = 2.4 V to V _{OUT} = 19.2 V <i>Figure 4.</i>	-	0.7		V/μs
dV _{OUT} /dt _(off)	Turn-off voltage slope	R _L = 48 Ω from V _{OUT} = 21.6 V to V _{OUT} = 2.4 V <i>Figure 4.</i>	-	1.5		V/μs

Table 5. Input pin

Symbol	Parameter	Test conditions	Min	Typ	Max	Unit
V_{INL}	Input low-level				1.25	V
I_{INL}	Low-level input current	$V_{IN} = 1.25\text{ V}$	1			μA
V_{INH}	Input high-level		2.25			V
I_{INH}	High-level input current	$V_{IN} = 2.25\text{ V}$			10	μA
$V_{I(HYST)}$	Input hysteresis voltage		0.25			V
V_{ICL}	Input clamp voltage	$I_{IN} = 1\text{ mA}$ $I_{IN} = -1\text{ mA}$	6.0	6.8 -0.7	8.0	V V

Table 6. Protections

Symbol	Parameter	Test conditions	Min	Typ	Max	Unit
T_{CSD}	Case shutdown temperature		125	130	135	$^{\circ}\text{C}$
T_{CR}	Case reset temperature		110			$^{\circ}\text{C}$
T_{CHYST}	Case thermal hysteresis		7	15		$^{\circ}\text{C}$
T_{TSD}	Junction shutdown temperature		150	175	200	$^{\circ}\text{C}$
T_R	Junction reset temperature		135			$^{\circ}\text{C}$
T_{HYST}	Junction thermal hysteresis		7	15		$^{\circ}\text{C}$
I_{lim}	DC short-circuit current	$V_{CC} = 24\text{ V}; R_{LOAD} = 10\text{ m}\Omega$	0.7		1.7	A
V_{demag}	Turn-off output clamp voltage	$I_{OUT} = 0.5\text{ A}; L = 6\text{ mH}$	$V_{CC}-57$	$V_{CC}-52$	$V_{CC}-47$	V

Table 7. Status pin

Symbol	Parameter	Test conditions	Min	Typ	Max	Unit
I_{HSTAT}	High-level output current	$V_{CC} = 18\dots32\text{ V}; R_{STAT} = 1\text{ k}\Omega$ (Fault condition)	2	3	4	mA
I_{LSTAT}	Leakage current	Normal operation; $V_{CC} = 32\text{ V}$			0.1	μA
V_{CLSTAT}	Clamp voltage	$I_{STAT} = 1\text{ mA}$ $I_{STAT} = -1\text{ mA}$	6.0	6.8 -0.7	8.0	V V

3 Pin connections

Figure 2. Connection diagram (top view)

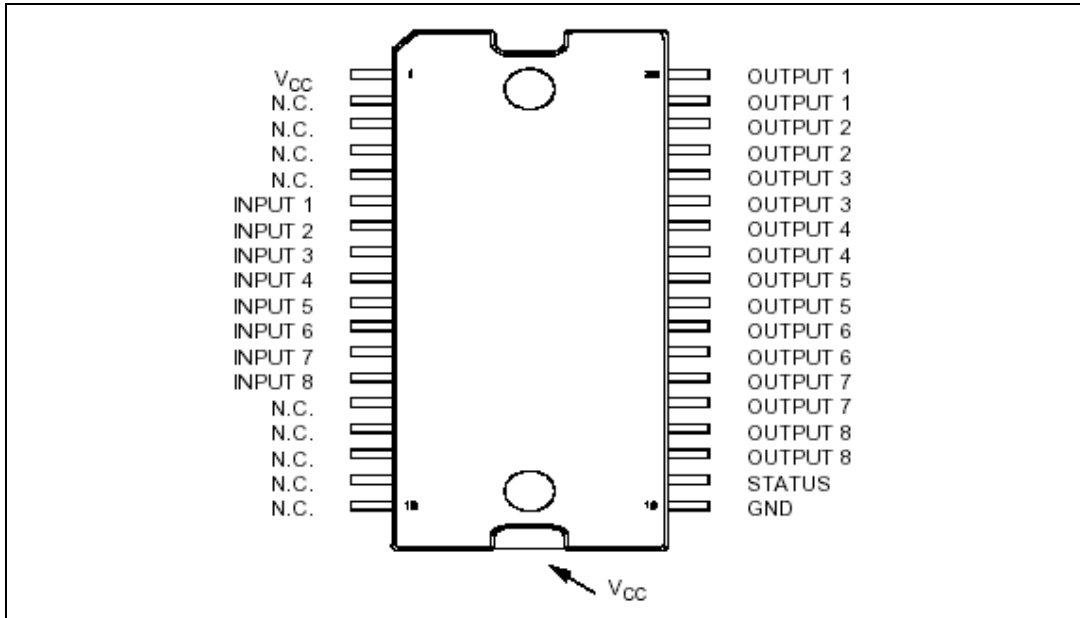

Table 8. Pin functions

Pin N°	Symbol	Function
TAB	V _{CC}	Positive power supply voltage
1	V _{CC}	Positive power supply voltage
2,3,4,5	NC	Not connected
6	Input 1	Input of channel 1
7	Input 2	Input of channel 2
8	Input 3	Input of channel 3
9	Input 4	Input of channel 4
10	Input 5	Input of channel 5
11	Input 6	Input of channel 6
12	Input 7	Input of channel 7
13	Input 8	Input of channel 8
14,15,16,17,18	NC	Not connected
19	GND	Logic ground
20	STATUS	Common open source diagnostic for over-temperature
21,22	Output 8	High-side output of channel 8
23,24	Output 7	High-side output of channel 7
25,26	Output 6	High-side output of channel 6

Table 8. Pin functions (continued)

Pin N°	Symbol	Function
27,28	Output 5	High-side output of channel 5
29,30	Output 4	High-side output of channel 4
31,32	Output 3	High-side output of channel 3
33,34	Output 2	High-side output of channel 2
35,36	Output 1	High-side output of channel 1

4 Current, voltage conventions and truth table

Figure 3. Current and voltage conventions

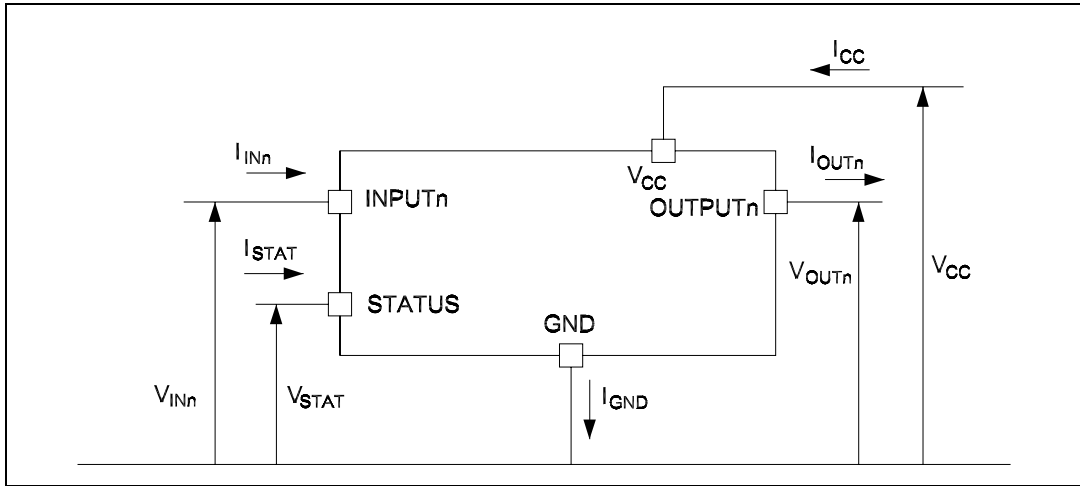

Table 9. Truth table

Conditions	INPUTn	OUTPUTn	STATUS
Normal operation	L	L	L
	H	H	L
Current limitation	L	L	L
	H	X	L
Overtemperature (see waveforms 3, 4 Figure 6) -> $T_J > T_{TSD}$	L	L	L
	H	L	H
Undervoltage	L	L	X
	H	L	X

5 Switching time waveforms

Figure 4. Turn-ON and turn-OFF

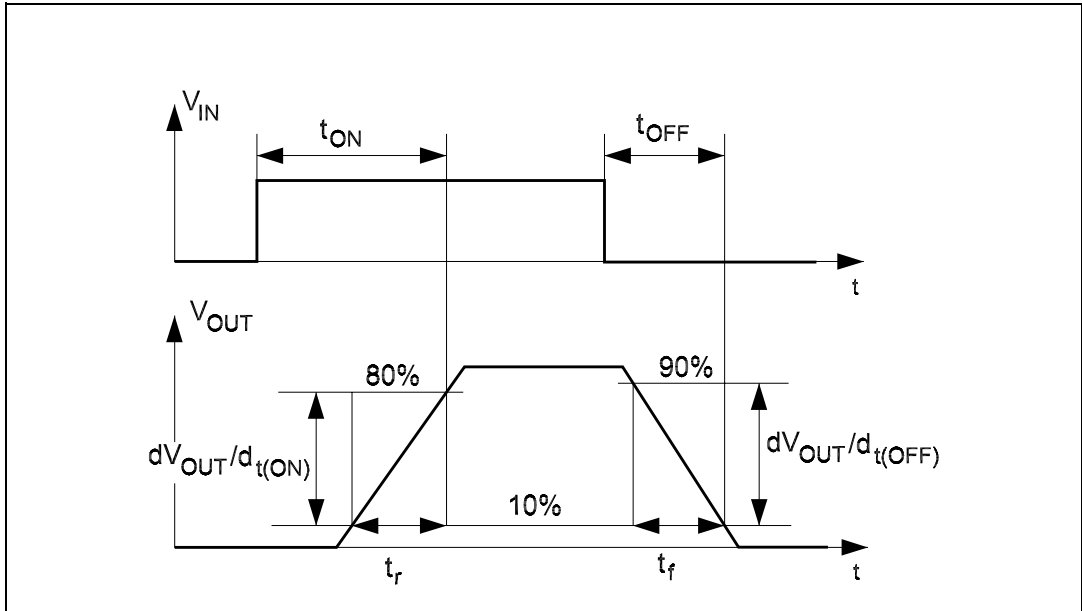

Figure 5. V_{CC} turn-ON

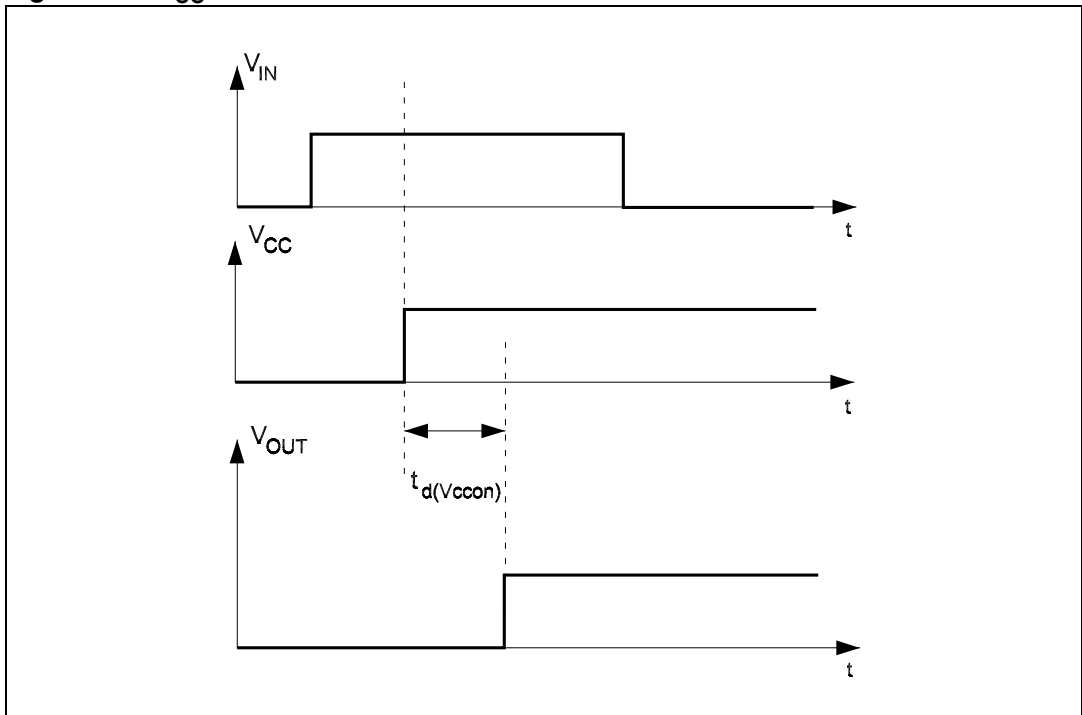

Figure 6. Waveforms

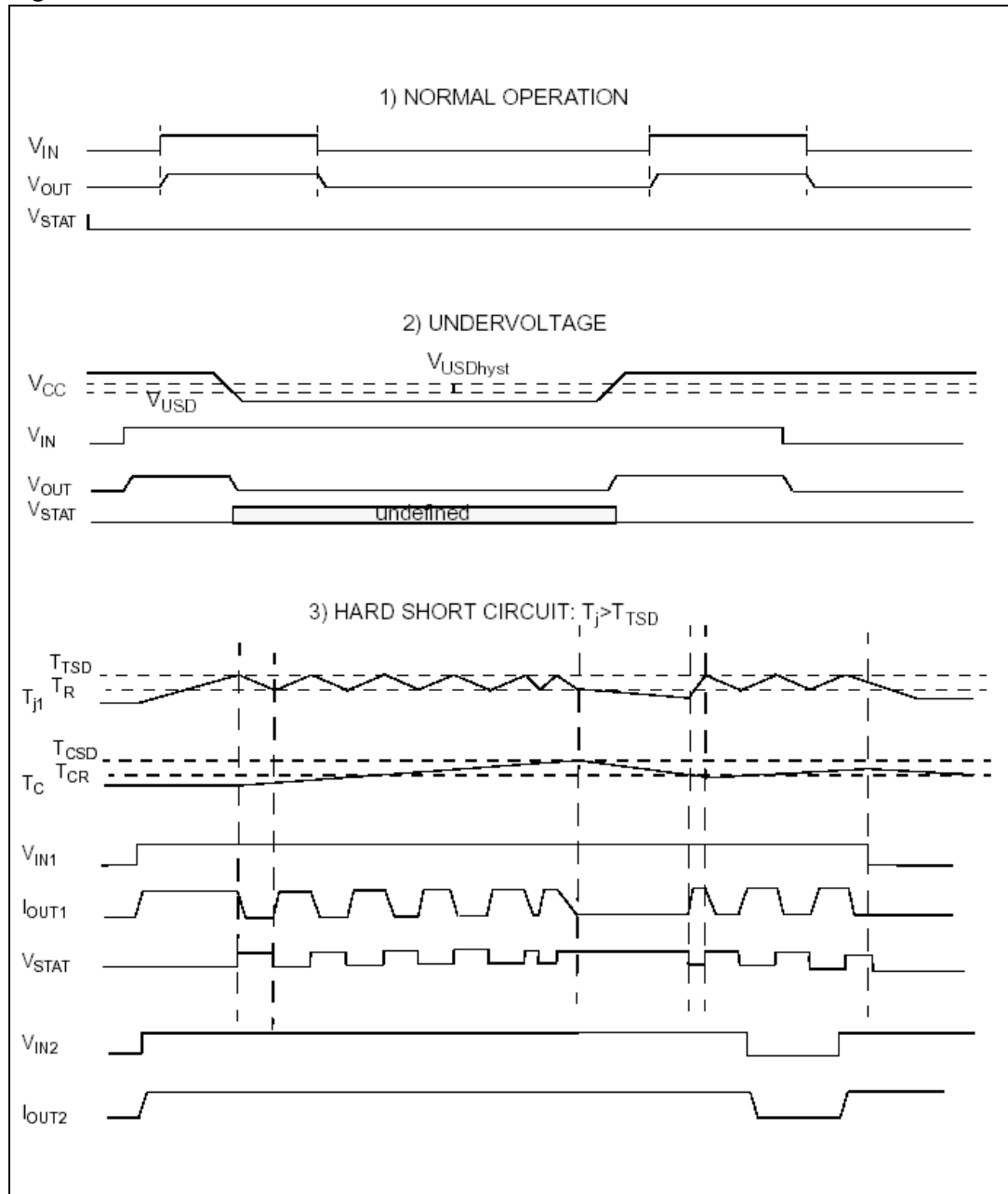
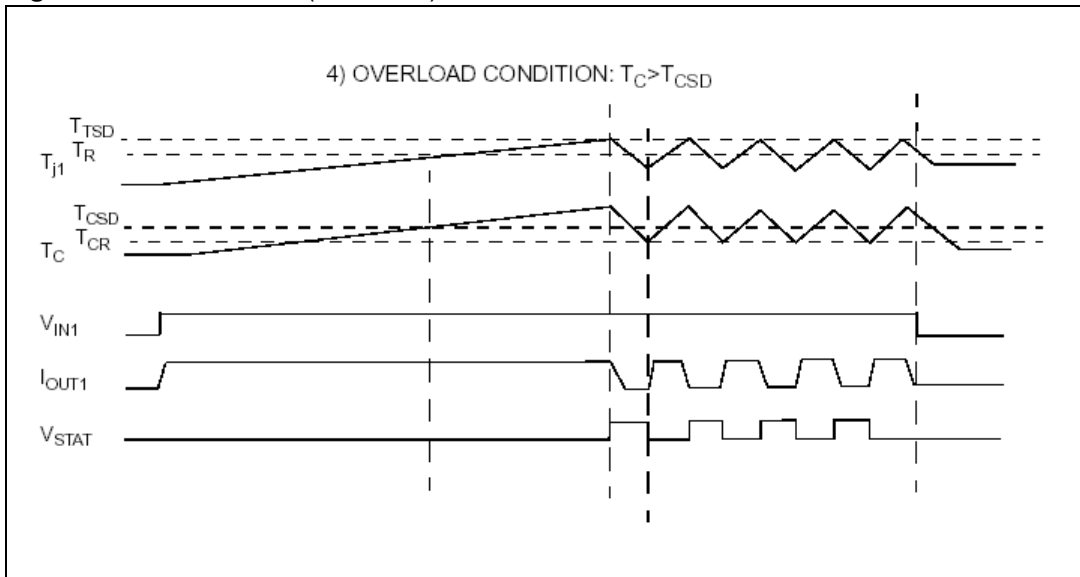

Figure 6. Waveforms (continued)



6 Reverse polarity protection

This schematic can be used with any type of load.

The following is an indication on how to dimension the R_{GND} resistor.

$$R_{GND} = (-V_{CC}) / (-I_{GND})$$

where $-I_{GND}$ is the DC reverse ground pin current and can be found in the absolute maximum rating section of the device datasheet.

Power dissipation in R_{GND} (when $V_{CC} < 0$: during reverse polarity situations) is:

$$PD = (-V_{CC})^2 / R_{GND}$$

Note: In normal condition (no reverse polarity) due to the diode there will be a voltage drop between GND of the device and GND of the system.

Figure 7. Reverse polarity protection

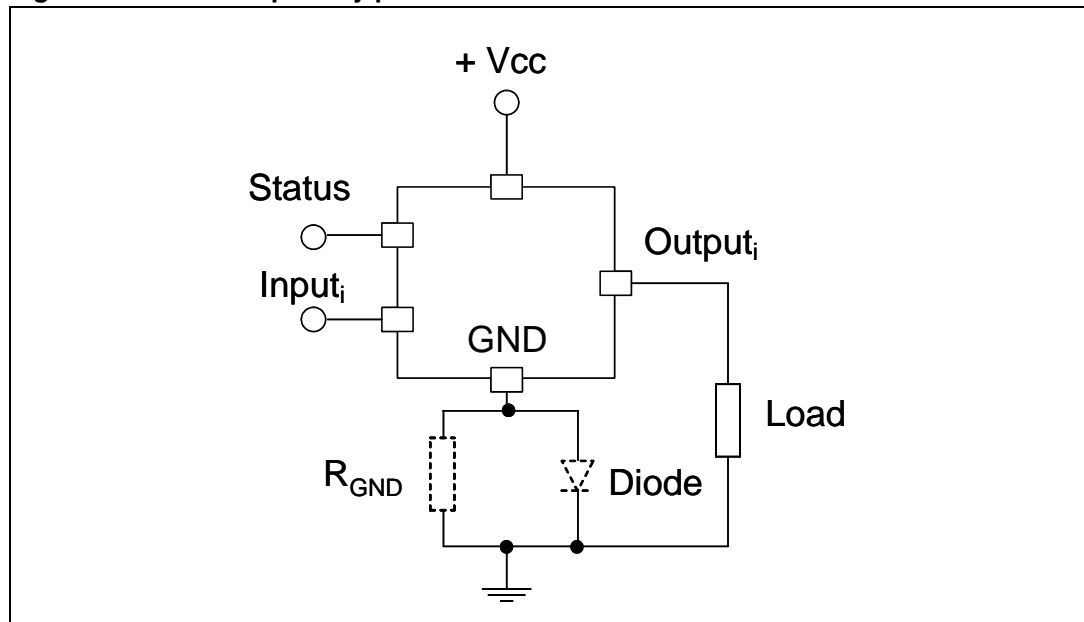

7 Package mechanical data

In order to meet environmental requirements, ST offers these devices in different grades of ECOPACK[®] packages, depending on their level of environmental compliance. ECOPACK[®] specifications, grade definitions and product status are available at: www.st.com. ECOPACK is an ST trademark.

Table 10. PowerSO-36 mechanical data

Dim.	mm			inch		
	Min.	Typ.	Max.	Min.	Typ.	Max.
A			3.60			0.1417
a1	0.10		0.30	0.003		0.0118
a2			3.30			0.1299
a3	0		0.10	0		0.0039
b	0.22		0.38	0.008		0.0150
c	0.23		0.32	0.009		0.0126
D (1)	15.80		16.00	0.622		0.6299
D1	9.40		9.80	0.370		0.3858
E	13.90		14.50	0.547		0.5709
E1 (1)	10.90		11.10	0.429		0.4370
E2			2.90			0.1142
E3	5.8		6.2	0.228		0.2441
e		0.65			0.025	
e3		11.05			0.435	
G	0		0.10	0.000		0.0039
H	15.50		15.90	0.610		0.6260
h			1.10			0.0433
L	0.80		1.10	0.031		0.0433
N			10°			10°
S	0°		8°	0°		8°

Figure 8. PowerSO-36 drawings

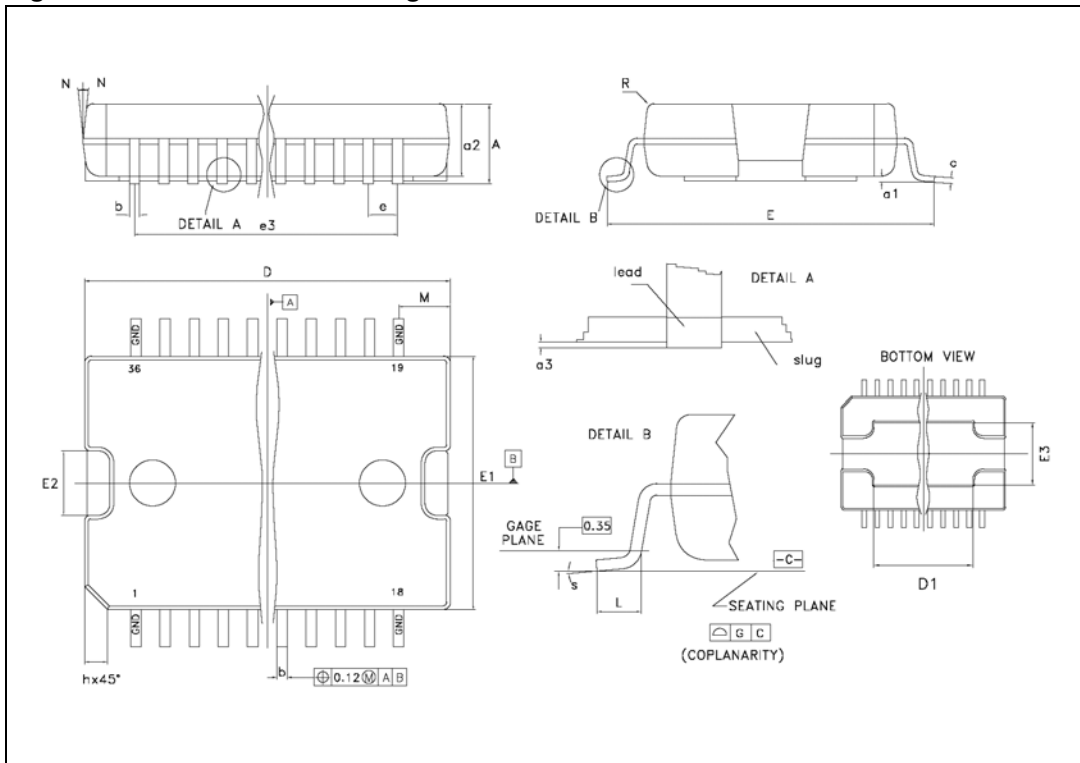
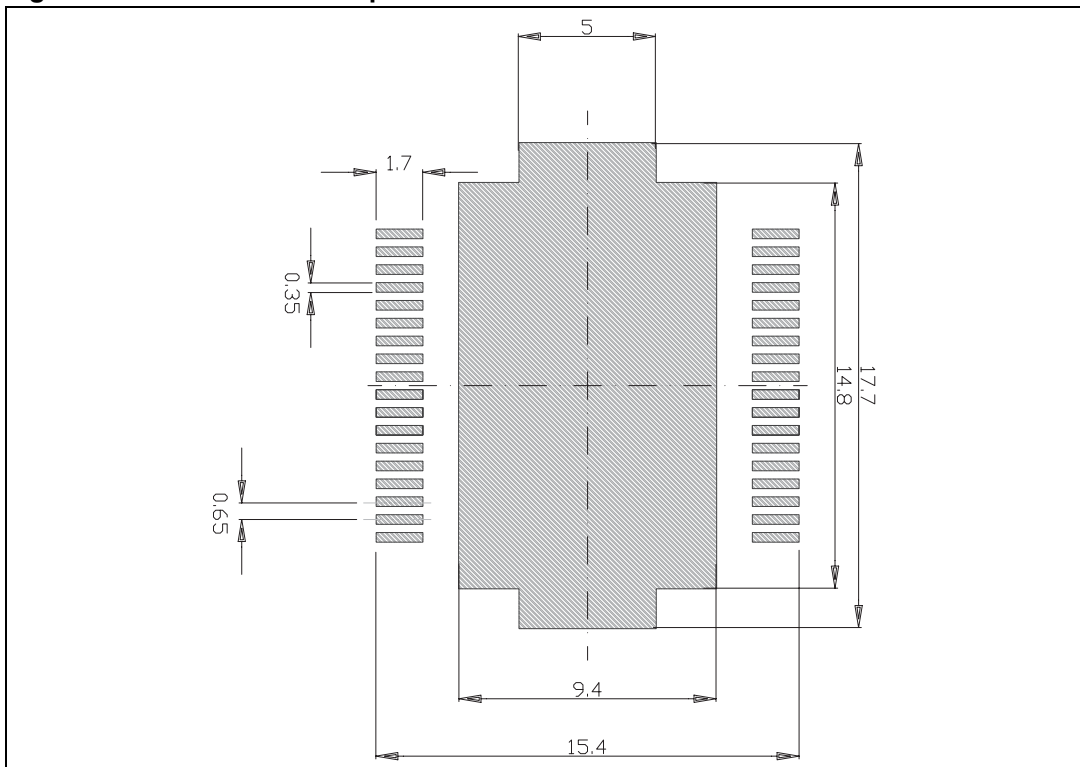

Figure 9. PowerSO-36 footprint



8 Order codes

Table 11. Order codes

Order codes	Package	Packaging
VN808CM-E	PowerSO-36	Tube
VN808CMTR-E	PowerSO-36	Tape and reel

9 Revision history

Table 12. Document revision history

Date	Revision	Changes
29-Jun-2005	1	Initial release
12-Sep-2005	2	New template
28-Jun-2006	3	Application schematic updated
09-Jul-2008	4	Added <i>Section 6: Reverse polarity protection</i>
04-Aug-2008	5	Added <i>Figure 9: PowerSO-36 footprint</i>
26-Aug-2009	6	Updated <i>Section 6: Reverse polarity protection</i>
15-Sep-2009	7	Typing mistake in cover page: <i>Section : Features</i> and <i>Table 5: Input pin</i>

Please Read Carefully:

Information in this document is provided solely in connection with ST products. STMicroelectronics NV and its subsidiaries ("ST") reserve the right to make changes, corrections, modifications or improvements, to this document, and the products and services described herein at any time, without notice.

All ST products are sold pursuant to ST's terms and conditions of sale.

Purchasers are solely responsible for the choice, selection and use of the ST products and services described herein, and ST assumes no liability whatsoever relating to the choice, selection or use of the ST products and services described herein.

No license, express or implied, by estoppel or otherwise, to any intellectual property rights is granted under this document. If any part of this document refers to any third party products or services it shall not be deemed a license grant by ST for the use of such third party products or services, or any intellectual property contained therein or considered as a warranty covering the use in any manner whatsoever of such third party products or services or any intellectual property contained therein.

UNLESS OTHERWISE SET FORTH IN ST'S TERMS AND CONDITIONS OF SALE ST DISCLAIMS ANY EXPRESS OR IMPLIED WARRANTY WITH RESPECT TO THE USE AND/OR SALE OF ST PRODUCTS INCLUDING WITHOUT LIMITATION IMPLIED WARRANTIES OF MERCHANTABILITY, FITNESS FOR A PARTICULAR PURPOSE (AND THEIR EQUIVALENTS UNDER THE LAWS OF ANY JURISDICTION), OR INFRINGEMENT OF ANY PATENT, COPYRIGHT OR OTHER INTELLECTUAL PROPERTY RIGHT.

UNLESS EXPRESSLY APPROVED IN WRITING BY AN AUTHORIZED ST REPRESENTATIVE, ST PRODUCTS ARE NOT RECOMMENDED, AUTHORIZED OR WARRANTED FOR USE IN MILITARY, AIR CRAFT, SPACE, LIFE SAVING, OR LIFE SUSTAINING APPLICATIONS, NOR IN PRODUCTS OR SYSTEMS WHERE FAILURE OR MALFUNCTION MAY RESULT IN PERSONAL INJURY, DEATH, OR SEVERE PROPERTY OR ENVIRONMENTAL DAMAGE. ST PRODUCTS WHICH ARE NOT SPECIFIED AS "AUTOMOTIVE GRADE" MAY ONLY BE USED IN AUTOMOTIVE APPLICATIONS AT USER'S OWN RISK.

Resale of ST products with provisions different from the statements and/or technical features set forth in this document shall immediately void any warranty granted by ST for the ST product or service described herein and shall not create or extend in any manner whatsoever, any liability of ST.

ST and the ST logo are trademarks or registered trademarks of ST in various countries.

Information in this document supersedes and replaces all information previously supplied.

The ST logo is a registered trademark of STMicroelectronics. All other names are the property of their respective owners.

© 2009 STMicroelectronics - All rights reserved

STMicroelectronics group of companies

Australia - Belgium - Brazil - Canada - China - Czech Republic - Finland - France - Germany - Hong Kong - India - Israel - Italy - Japan - Malaysia - Malta - Morocco - Philippines - Singapore - Spain - Sweden - Switzerland - United Kingdom - United States of America

www.st.com