



VIPer12ADIP - E VIPer12AS - E

Low Power OFF-Line SMPS Primary Switcher

Features

- Fixed 60kHz Switching Frequency
- 9V to 38V Wide Range V_{DD} Voltage
- Current Mode Control
- Auxiliary Undervoltage Lockout with Hysteresis
- High Voltage Start-up Current Source
- Overtemperature, Overcurrent and Overvoltage Protection with Auto-Restart
- Typical power capability
 - European (195 - 265 Vac) 8W for SO-8, 13W for DIP-8
 - European (85 - 265 Vac) 5W for SO-8, 8W for DIP-8

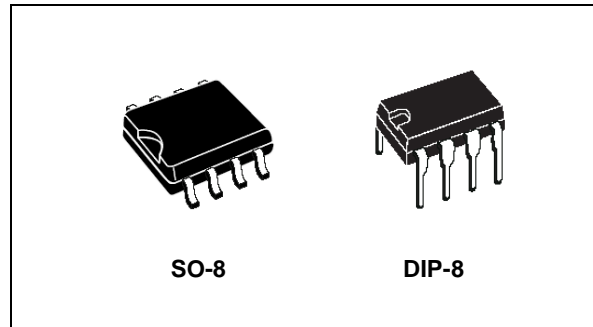

Typical applications cover off line power supplies for battery charger adapters, standby power supplies for TV or monitors, auxiliary supplies for motor control, etc.

The internal control circuit offers the following benefits:

- Large input voltage range on the V_{DD} pin accommodates changes in auxiliary supply voltage. This feature is well adapted to battery charger adapter configurations.
- Automatic burst mode in low load condition.
- Overvoltage protection in HICCUP mode.

Description

The VIPer12A combines a dedicated current mode PWM controller with a high voltage Power MOSFET on the same silicon chip.

Block diagram

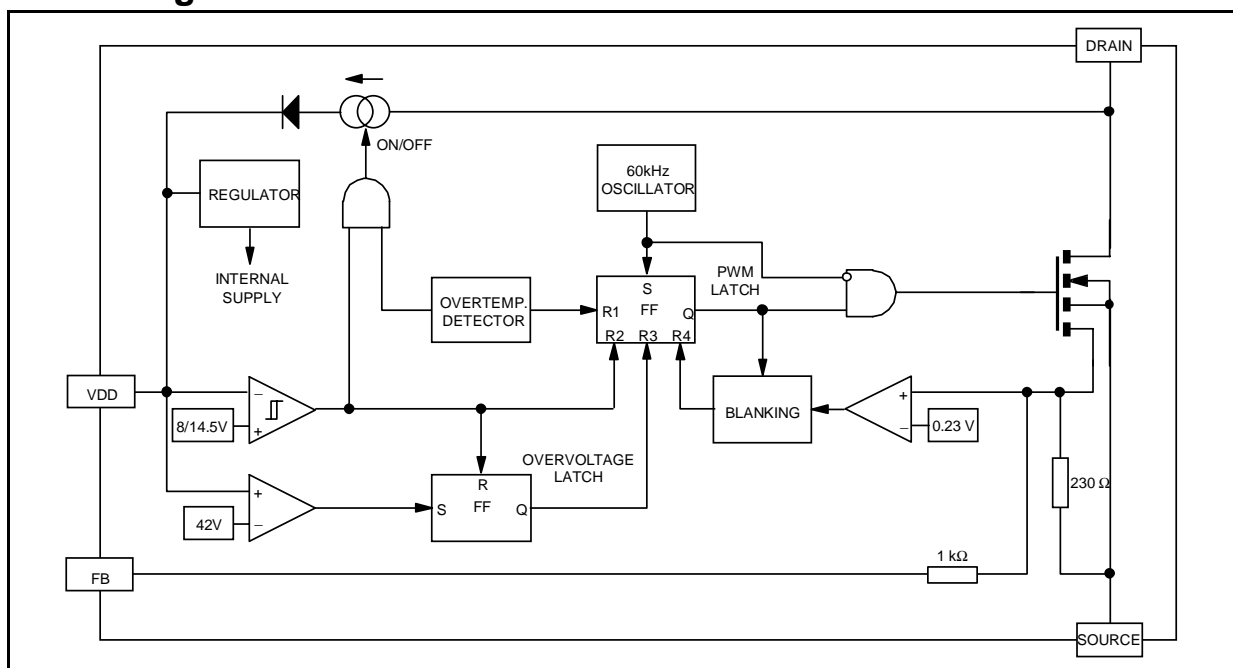

1 Electrical data

1.1 Maximum rating

Stressing the device above the rating listed in the “Absolute Maximum Ratings” table may cause permanent damage to the device. These are stress ratings only and operation of the device at these or any other conditions above those indicated in the Operating sections of this specification is not implied. Exposure to Absolute Maximum Rating conditions for extended periods may affect device reliability. Refer also to the STMicroelectronics SURE Program and other relevant quality documents.

Table 1. Absolute maximum rating

Symbol	Parameter	Value	Unit
$V_{DS(sw)}$	Switching drain source voltage ($T_J = 25 \dots 125^\circ\text{C}$) <i>Note 1</i>	-0.3 ... 730	V
$V_{DS(st)}$	Start-up drain source voltage ($T_J = 25 \dots 125^\circ\text{C}$) <i>Note 2</i>	-0.3 ... 400	V
I_D	Continuous drain current	Internally limited	A
V_{DD}	Supply voltage	0 ... 50	V
I_{FB}	Feedback current	3	mA
V_{ESD}	Electrostatic discharge: Machine model ($R = 0\Omega$; $C = 200\text{pF}$) Charged device model	200 1.5	V kV
T_J	Junction operating temperature	Internally limited	$^\circ\text{C}$
T_C	Case operating temperature	-40 to 150	$^\circ\text{C}$
T_{stg}	Storage Temperature	-55 to 150	$^\circ\text{C}$

- Note: 1 *This parameter applies when the start-up current source is OFF. This is the case when the V_{DD} voltage has reached V_{DDon} and remains above V_{DDoff} .*
- 2 *This parameter applies when the start up current source is on. This is the case when the V_{DD} voltage has not yet reached V_{DDon} or has fallen below V_{DDoff} .*

1.2 Thermal data

Table 2. Thermal data

Symbol	Parameter		SO-8	DIP-8	Unit
R_{thJC}	Thermal Resistance Junction-case	Max	25	15	$^\circ\text{C}/\text{W}$
R_{thJA}	Thermal Resistance Ambient-case ⁽¹⁾	Max	55	45	$^\circ\text{C}/\text{W}$

1. When mounted on a standard single-sided FR4 board with 200 mm² of Cu (at least 35 μm thick) connected to all DRAIN pins.

2 Electrical characteristics

$T_J = 25^\circ\text{C}$, $V_{DD} = 18\text{V}$, unless otherwise specified

Table 3. Power section

Symbol	Parameter	Test conditions	Min.	Typ.	Max.	Unit
BV_{DSS}	Drain-source voltage	$I_D = 1\text{mA}$; $V_{FB} = 2\text{V}$	730			V
I_{DSS}	OFF State drain current	$V_{DS} = 500\text{V}$; $V_{FB} = 2\text{V}$; $T_J = 125^\circ\text{C}$			0.1	mA
$r_{DS(on)}$	Static drain-source ON state resistance	$I_D = 0.2\text{A}$ $I_D = 0.2\text{A}$; $T_J = 100^\circ\text{C}$		27	30 54	Ω
t_f	Fall time	$I_D = 0.1\text{A}$; $V_{IN} = 300\text{V}$ <i>Note 1 (See Figure 8 on page 13)</i>		100		ns
t_r	Rise time	$I_D = 0.2\text{A}$; $V_{IN} = 300\text{V}$ <i>Note 1 (See Figure 8 on page 13)</i>		50		ns
C_{OSS}	Drain capacitance	$V_{DS} = 25\text{V}$		40		pF

Note: 1 On clamped inductive load

Table 4. Supply section

Symbol	Parameter	Test conditions	Min.	Typ.	Max.	Unit
I_{DDch}	Start-up charging current	$V_{DS} = 100\text{V}$; $V_{DD} = 5\text{V} \dots V_{DDon}$ (See Figure 9 on page 13)		-1		mA
I_{DDoff}	Start-up charging current in thermal shutdown	$V_{DD} = 5\text{V}$; $V_{DS} = 100\text{V}$ $T_J > T_{SD} - T_{HYST}$	0			mA
I_{DD0}	Operating supply current not switching	$I_{FB} = 2\text{mA}$		3	5	mA
I_{DD1}	Operating supply current switching	$I_{FB} = 0.5\text{mA}$; $I_D = 50\text{mA}$ <i>Note 2</i>		4.5		mA
D_{RST}	Restart duty-cycle	(See Figure 10 on page 13)		16		%
V_{DDoff}	V_{DD} Undervoltage shutdown threshold	(See Figure 9, Figure 10 on page 13)	7	8	9	V
V_{DDon}	V_{DD} Start-up threshold	(See Figure 9, Figure 10 on page 13))	13	14.5	16	V
V_{DDhyst}	V_{DD} Threshold hysteresis	(See Figure 9 on page 13)	5.8	6.5	7.2	V
V_{DDovp}	V_{DD} Overvoltage threshold		38	42	46	V

2 These test conditions obtained with a resistive load are leading to the maximum conduction time of the device.

Table 5. Oscillation section

Symbol	Parameter	Test conditions	Min.	Typ.	Max.	Unit
F_{OSC}	Oscillator frequency total variation	$V_{DD} = V_{DDoff} \dots 35V$; $T_J = 0 \dots 100^\circ C$	54	60	66	kHz

Table 6. PWM Comparator section

Symbol	Parameter	Test Conditions	Min.	Typ.	Max.	Unit
G_{ID}	I_{FB} to I_D current gain	(See Figure 11 on page 14)		320		
I_{Dim}	Peak current limitation	$V_{FB} = 0V$ (See Figure 11 on page 14)	0.32	0.4	0.48	A
I_{FBsd}	I_{FB} Shutdown current	(See Figure 11 on page 14)		0.9		mA
R_{FB}	FB Pin input impedance	$I_D = 0mA$ (See Figure 11 on page 14)		1.2		k Ω
t_d	Current sense delay to turn-OFF	$I_D = 0.2A$		200		ns
t_b	Blanking time			500		ns
t_{ONmin}	Minimum Turn-ON time			700		ns

Table 7. Overtemperature section

Symbol	Parameter	Test Conditions	Min.	Typ.	Max.	Unit
T_{SD}	Thermal shutdown temperature	(See Figure 12 on page 14)	140	170		$^\circ C$
T_{HYST}	Thermal shutdown hysteresis	(See Figure 12 on page 14)		40		$^\circ C$

Table 8. Typical Power Capability

Mains type	SO-8	DIP-8
European (195 - 265 Vac)	8W	13W
US / Wide range (85 - 265 Vac)	5W	8W

Table 10. DIP8 Mechanical Data

Dimensions			
Ref.	Databook (mm)		
	Nom.	Min	Max
A			5.33
A1	0.38		
A2	2.92	3.30	4.95
b	0.36	0.46	0.56
b2	1.14	1.52	1.78
c	0.20	0.25	0.36
D	9.02	9.27	10.16
E	7.62	7.87	8.26
E1	6.10	6.35	7.11
e		2.54	
eA		7.62	
eB			10.92
L	2.92	3.30	3.81
Package Weight	Gr. 470		

Figure 15. Package Dimensions

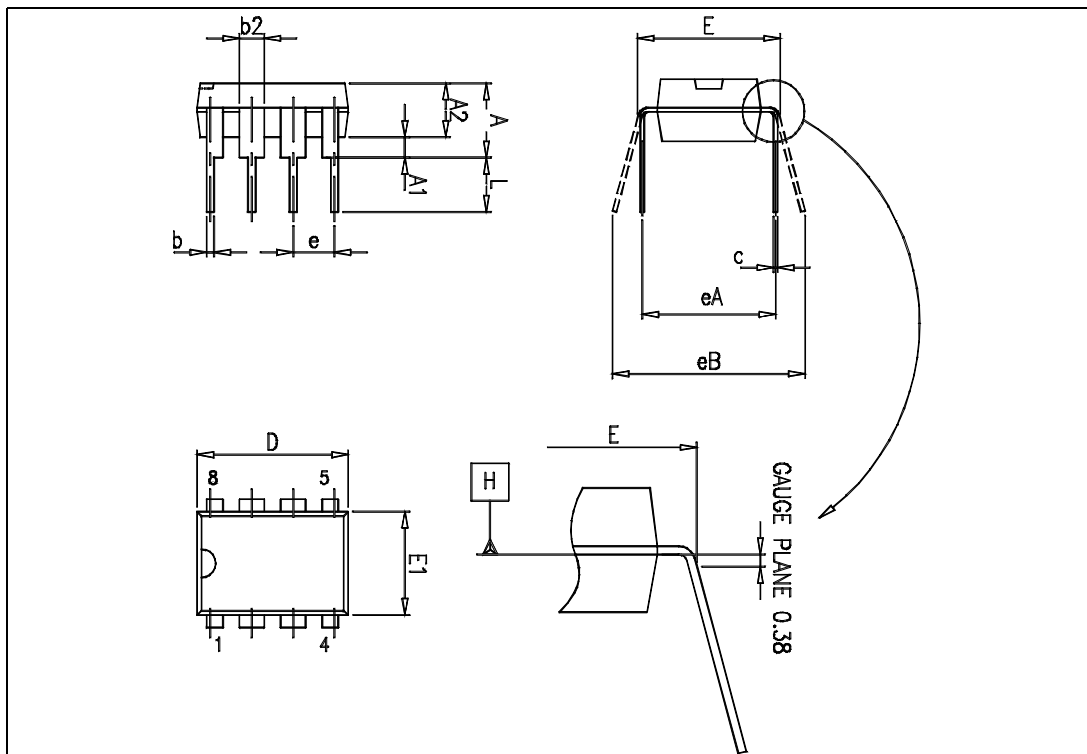

11 Order codes

Table 12. Order codes

Part Number	Package	Shipment
VIPER12ASTR-E	SO-8	Tape and Reel
VIPer12AS - E	SO-8	Tube
VIPer12ADIP - E	DIP-8	Tube