



ULN2064B, ULN2066B ULN2068B, ULN2074B

50 V - 1.5 A quad Darlington switches

Features

- Output current to 1.5 A for each Darlington
- Minimum breakdown 50 V
- Sustaining voltage at least 35 V
- Integral suppression diodes (ULN2064B, ULN2066B and ULN2068B)
- Isolated Darlington pinout (ULN2074B)
- Versions compatible with all popular logic families

Description

Designed to interface logic to a wide variety of high current, high voltage loads, these devices each contain four NPN Darlington switches delivering up to 1.5 A with a specified minimum breakdown of 50 V and a sustaining voltage of 35 V measured at 100 mA. The ULN2064B, ULN2066B and ULN2068B contain integral suppression diodes for inductive loads have common emitters. The ULN2074B feature isolated Darlington pinouts and is intended for

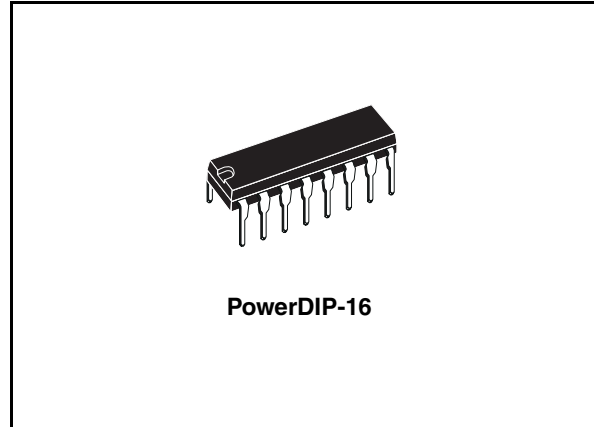

applications such as emitter follower configurations. Inputs of the ULN2064B, ULN2068B and ULN2074B are compatible with popular 5 V logic families and the ULN2066B are compatible with 6 - 15 V CMOS and PMOS. Type ULN2068B includes a pre-driver stage to reduce loading on the control logic.

Table 1. Device summary

Part numbers	Package
ULN2064B	PowerDIP-16
ULN2066B	PowerDIP-16
ULN2068B	PowerDIP-16
ULN2074B	PowerDIP-16

Contents

1	Diagram	3
2	Pin configuration	4
3	Maximum ratings	5
4	Electrical characteristics	6
5	Test circuits	7
6	Mounting instructions	9
7	Typical applications	10
8	Package mechanical data	11
9	Revision history	13

1 Diagram

Figure 1. Schematic diagrams

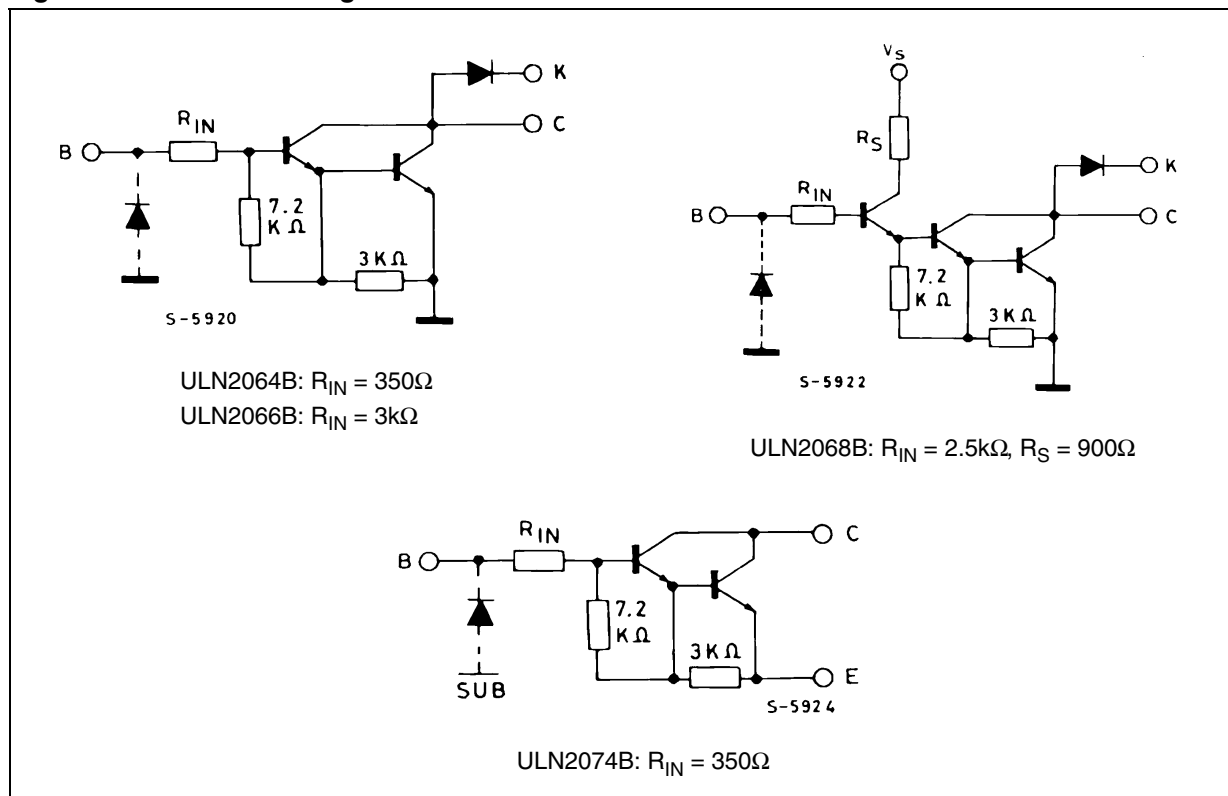

2 Pin configuration

Figure 2. Pin connections (top view)

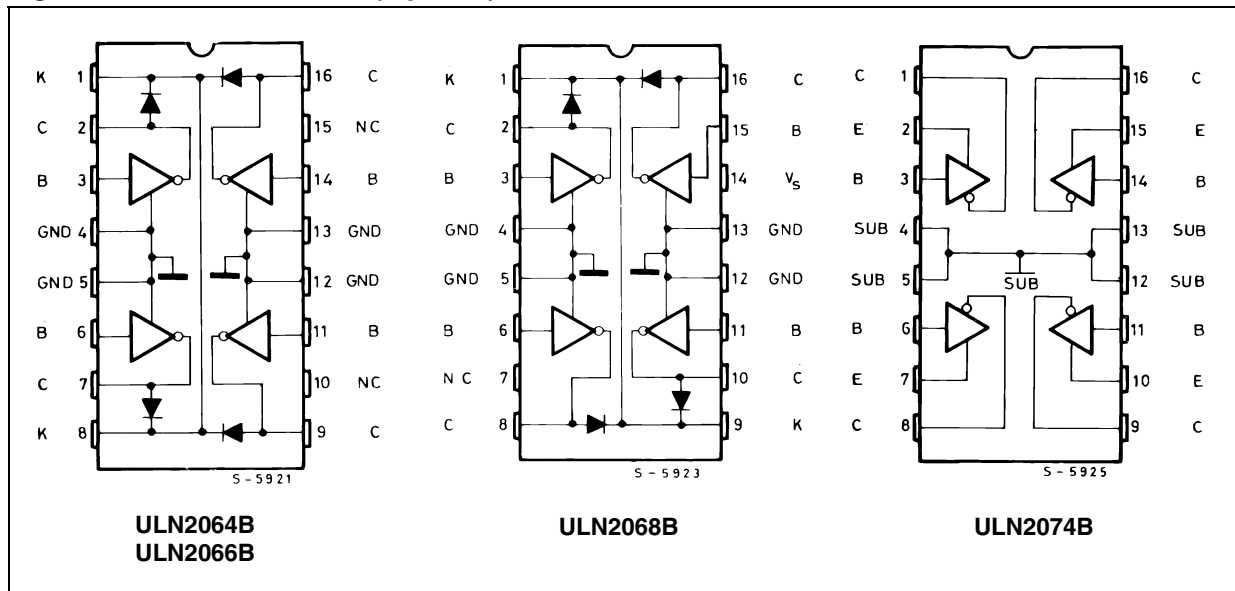

3 Maximum ratings

Table 2. Absolute maximum ratings

Symbol	Parameter	Value	Unit
V_{CEX}	Output voltage	50	V
$V_{CE(SUS)}$	Output sustaining voltage	35	V
I_O	Output current	1.75	A
V_I	Input voltage ULN2066B - 2074B	30	V
	Input voltage ULN2064B - 2068B	15	
I_I	Input current	25	mA
V_S	Supply voltage for ULN2068B	10	V
P_{TOT}	Power dissipation at $T_{PINS} = 90\text{ °C}$	4.3	W
	Power dissipation at $T_{AMB} = 70\text{ °C}$	1	
T_{AMB}	Operating ambient temperature range	- 20 to 85	°C
T_{STG}	Storage temperature	- 55 to 150	°C

4 Electrical characteristics

Table 3. Electrical characteristics ($T_A = 25^\circ\text{C}$ unless otherwise specified).

Symbol	Parameter	Test condition	Min.	Typ.	Max.	Unit
I_{CEX}	Output leakage current (<i>Figure 5</i>)	$V_{CE} = 50\text{V}$, $T_A = 25^\circ\text{C}$			100	μA
		$V_{CE} = 50\text{V}$, $T_A = 70^\circ\text{C}$			500	
$V_{CE(SUS)}$	Collector-emitter sustaining voltage (<i>Figure 4</i>)	$I_C = 100\text{mA}$, $V_I = 0.4\text{V}$	35			V
$V_{CE(SAT)}$	Collector-emitter saturation voltage (<i>Figure 5</i>)	$I_C = 500\text{mA}$, $I_B = 325\mu\text{A}$			1.1	V
		$I_C = 750\text{mA}$, $I_B = 935\mu\text{A}$			1.2	
		$I_C = 1\text{A}$, $I_B = 1.25\text{mA}$			1.3	
		$I_C = 1.25\text{A}$, $I_B = 2\text{mA}$			1.4	
$I_{I(ON)}$	Input current (<i>Figure 6</i>)	for ULN2064B and ULN2074B $V_I = 2.4\text{V}$ $V_I = 3.75\text{V}$	1.4 3.3		4.3 9.6	mA
		for ULN2066B, $V_I = 5\text{V}$ $V_I = 12\text{V}$	0.6 1.7		1.8 5.2	
		for ULN2068B, $V_I = 2.75\text{V}$ $V_I = 3.75\text{V}$			0.55 1.0	
$V_{I(ON)}$	Input voltage (<i>Figure 7</i>)	$V_{CE} = 2\text{V}$, $I_C = 1\text{A}$ ULN2064B, ULN2074B, ULN2066B			2 6.5	V
		$V_{CE} = 2\text{V}$, $I_C = 1.5\text{A}$ ULN2064B, ULN2074B, ULN2066B ULN2068B			2.5 10 2.75	
I_S	Supply current (<i>Figure 10</i>)	for ULN2068B, $V_I = 2.75\text{V}$, $I_C = 500\text{mA}$			6	mA
t_{PLH}	Turn-on delay time	$0.5 V_I$ to $0.5V_O$			1	μs
t_{PHL}	Turn-off delay time	$0.5 V_I$ to $0.5V_O$			1.5	μs
I_R	Clamp diode leakage current (<i>Figure 8</i>)	For ULN2064B - ULN2066B - ULN2068B, $V_R = 50\text{V}$ $T_A = 25^\circ\text{C}$ $T_A = 70^\circ\text{C}$			50 100	μA
V_F	Clamp diode forward voltage (<i>Figure 9</i>)	For ULN2064B - ULN2066B - ULN2068B $I_F = 1\text{A}$ $I_F = 1.5\text{A}$			1.75 2	V

Note: Input voltage is with reference to the substrate (no connection to any other pins) for the ULN2074B reference is ground for all other types.

Note: 1 Input current may be limited by maximum allowable input voltage.

5 Test circuits

Figure 3. Output leakage current

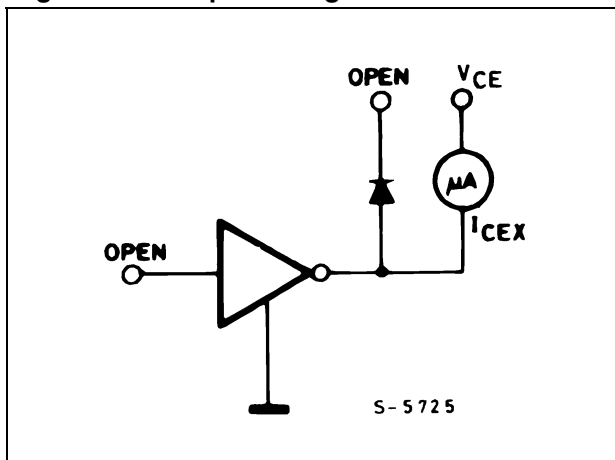

Figure 4. Collector-emitter sustaining voltage

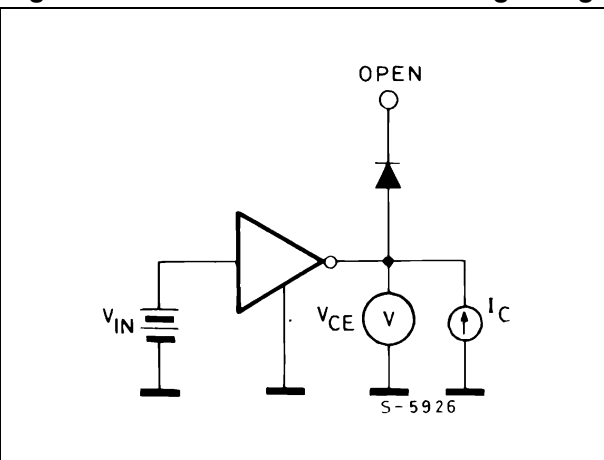

Figure 5. Collector-emitter saturation voltage

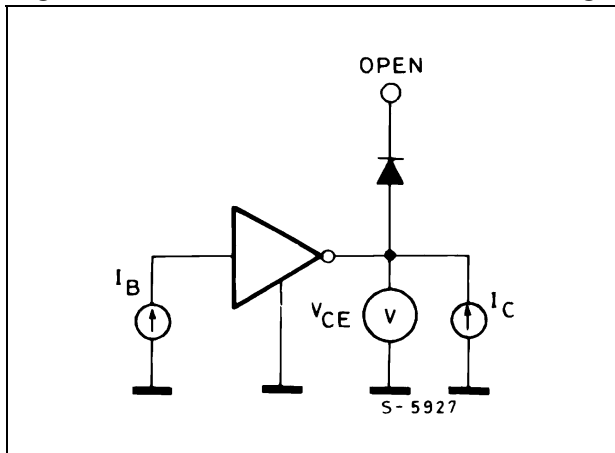

Figure 6. Input current (ON)

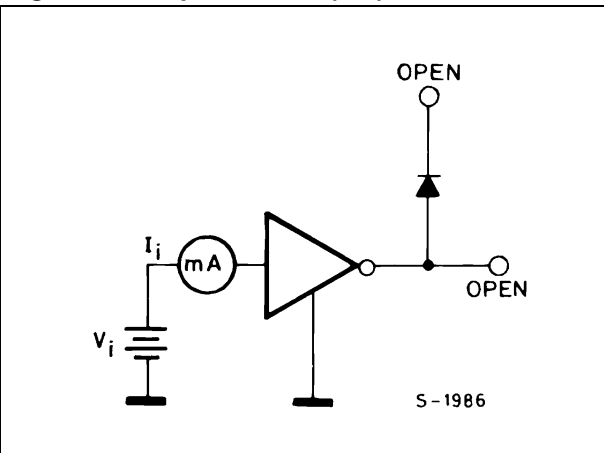

Figure 7. Input voltage

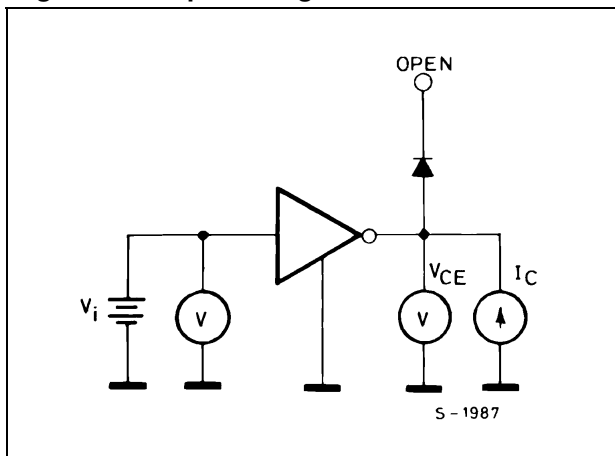

Figure 8. Clamp diode leakage current

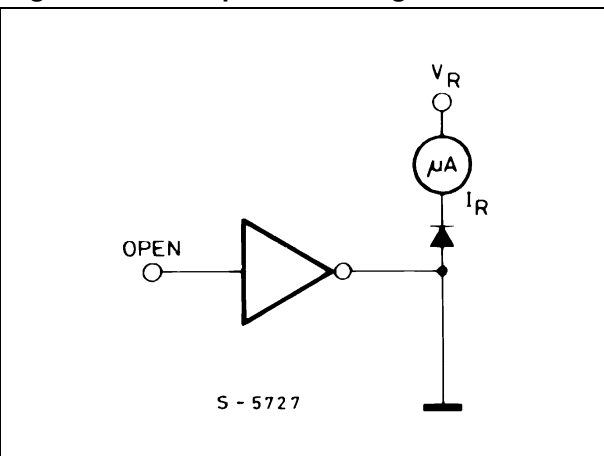

Figure 9. Clamp diode forward voltage

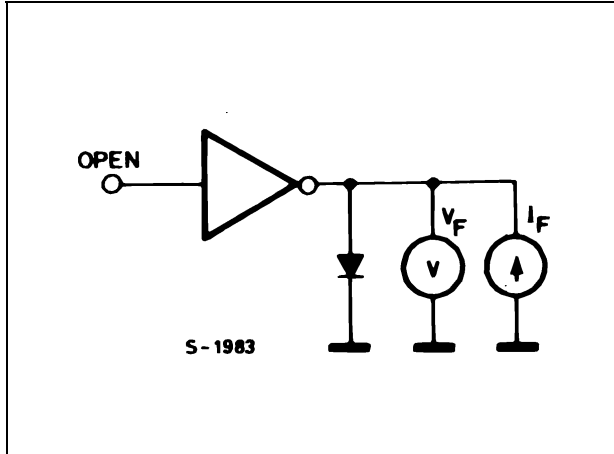

Figure 10. Supply current

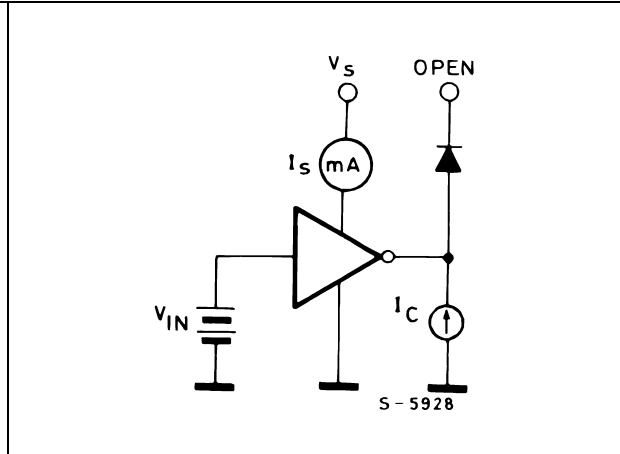

Figure 11. Input current as a function of input voltage

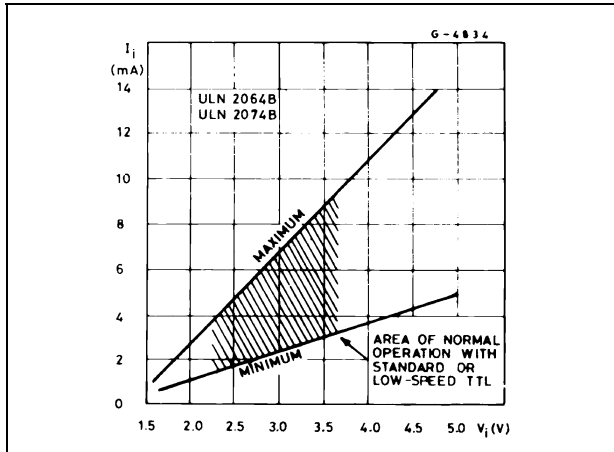

Figure 12. Input current as a function of input voltage

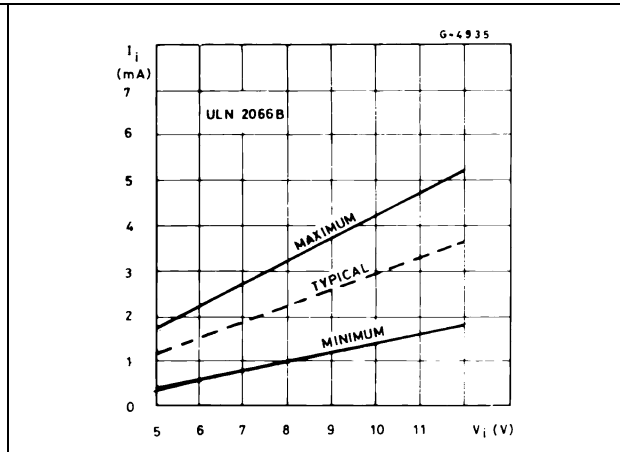
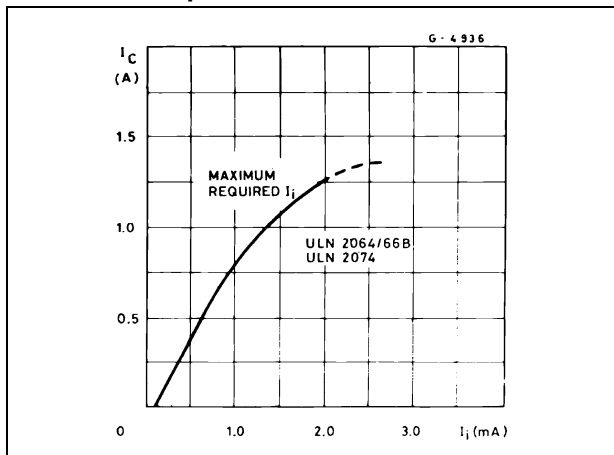

Figure 13. Collector current as a function of input current



6 Mounting instructions

The R_{thJA} can be reduced by soldering the GND pins to a suitable copper area of the printed circuit board (Figure 14) or to an external heatsink (Figure 15).

The diagram of Figure 16 shows the maximum dissipated power P_{TOT} and the R_{thJA} as a function of the side "α" of two equal square copper areas having a thickness of 35 μ (1.4 mils).

During soldering the pins temperature must not exceed 260 °C and the soldering time must not be longer than 12 seconds.

The external heatsink or printed circuit copper area must be connected to electrical ground.

Figure 14. Example of P.C. board area which is used as heatsink

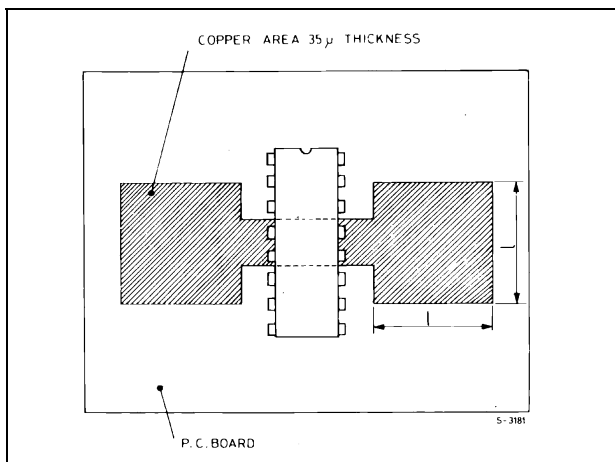

Figure 15. External heatsink mounting example

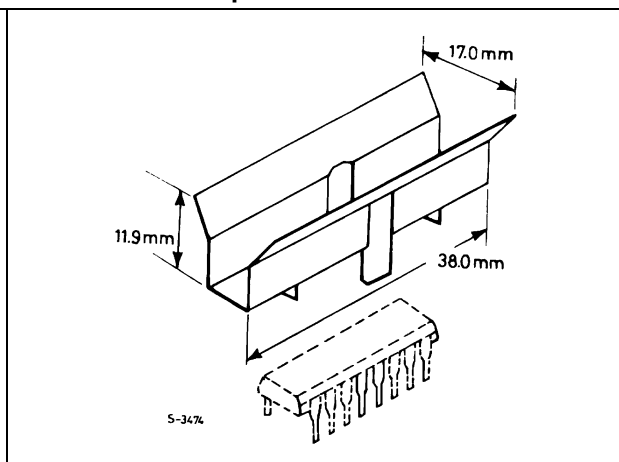

Figure 16. Maximum dissipated power and junction to ambient thermal resistance vs. side "α"

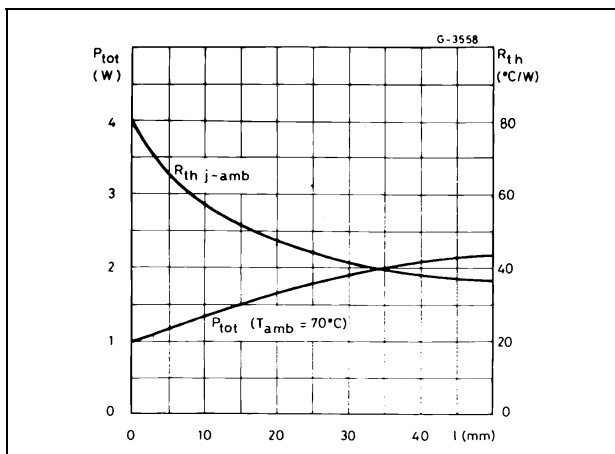
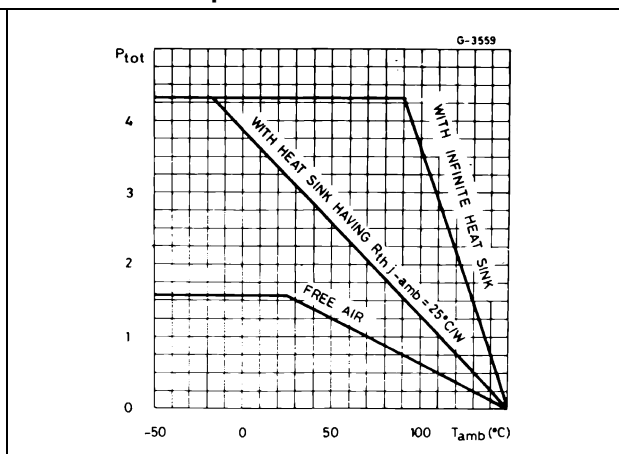

Figure 17. Maximum allowable power dissipation vs. ambient temperature



7 Typical applications

Figure 18. Common-anode LED drivers

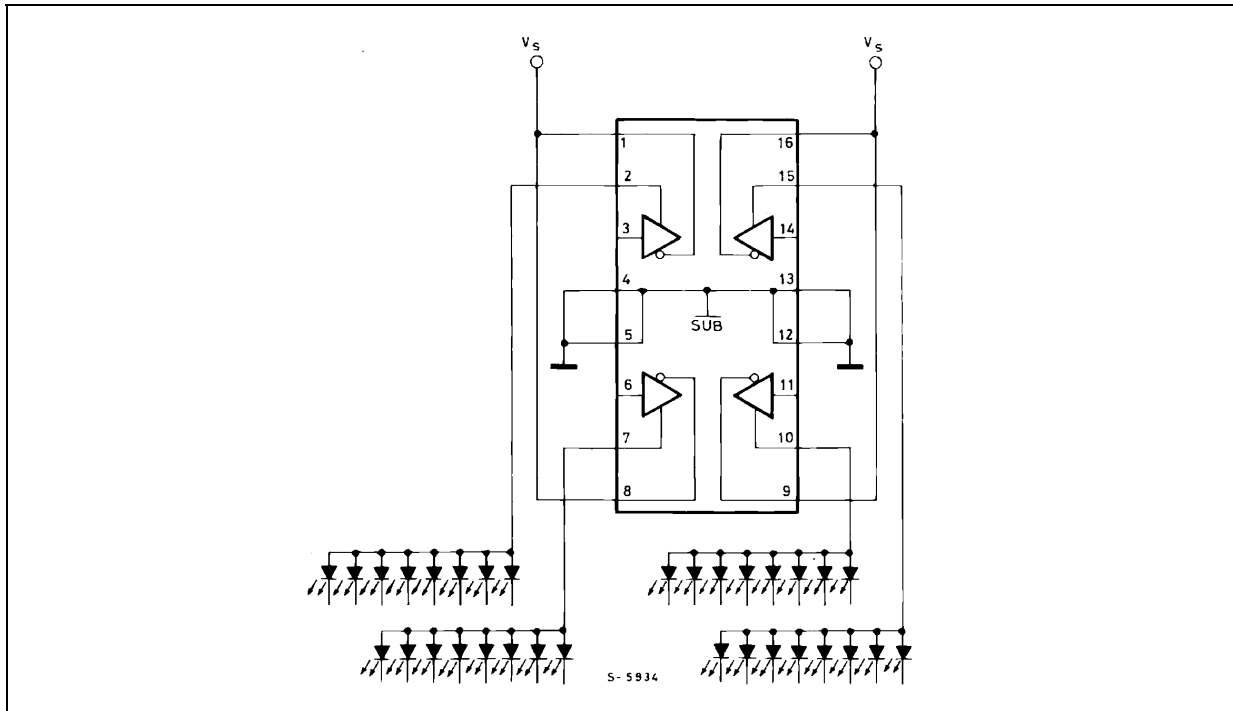
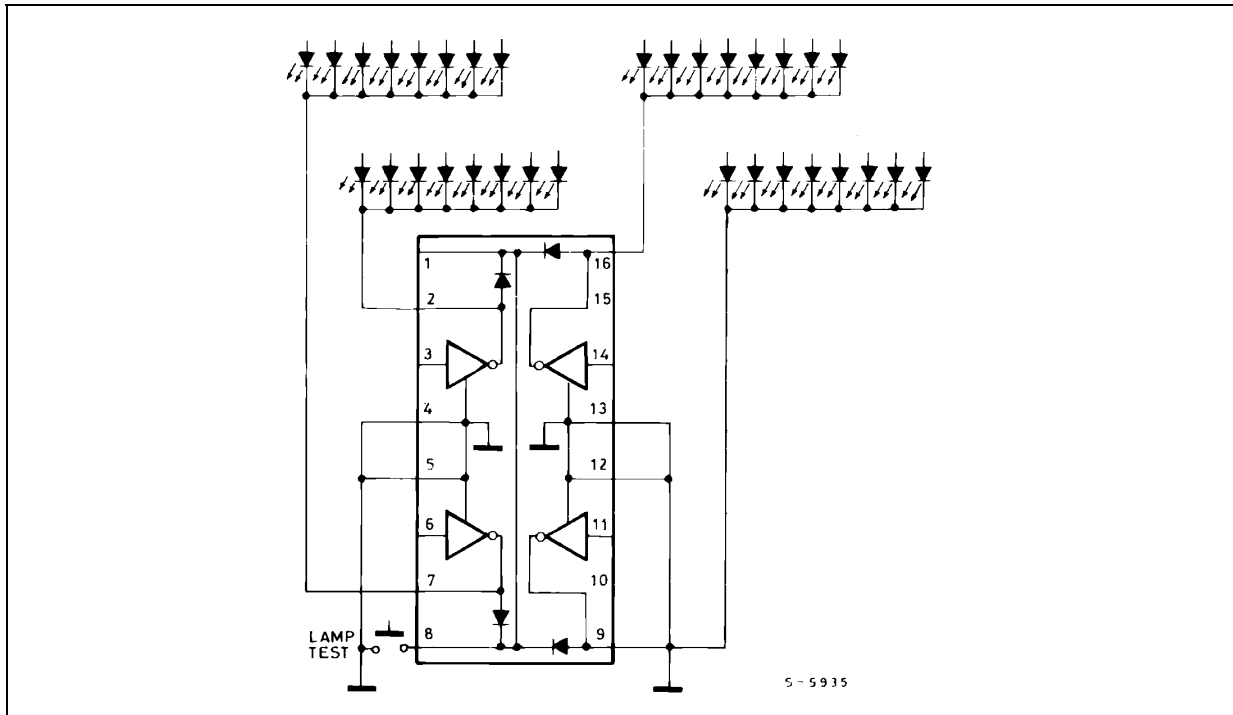

Figure 19. Common-cathode LED drivers



8 Package mechanical data

In order to meet environmental requirements, ST offers these devices in different grades of ECOPACK® packages, depending on their level of environmental compliance. ECOPACK® specifications, grade definitions and product status are available at: www.st.com. ECOPACK® is an ST trademark.

Dim.	mm			inch.		
	Min.	Typ.	Max.	Min.	Typ.	Max.
a1	0.51			0.020		
B	0.85		1.40	0.033		0.055
b		0.50			0.020	
b1	0.38		0.50	0.015		0.020
D			20.0			0.787
E		8.80			0.346	
e		2.54			0.100	
e3		17.78			0.700	
F			7.10			0.280
I			5.10			0.201
L		3.30			0.130	
Z			1.27			0.050

OUTLINE AND MECHANICAL DATA

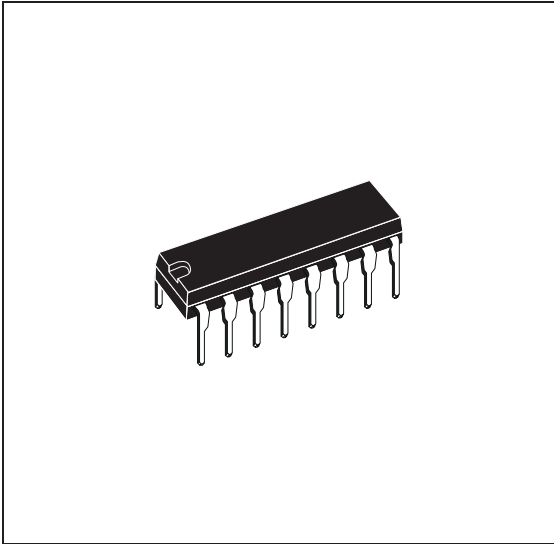

PowerDIP-16

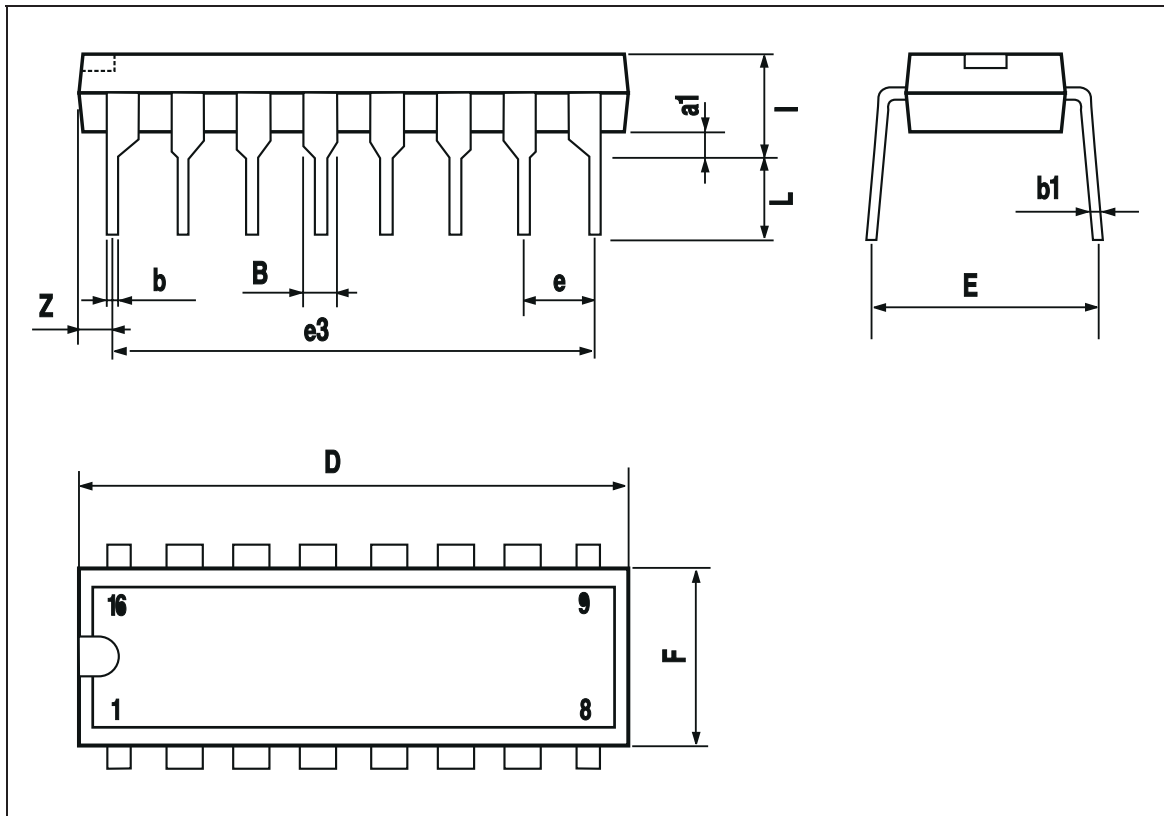

9 Revision history

Table 4. Document revision history

Date	Revision	Changes
12-Sep-2003	1	First release
22-Jan-2009	2	Modified Table 1 on page 1 .

Please Read Carefully:

Information in this document is provided solely in connection with ST products. STMicroelectronics NV and its subsidiaries ("ST") reserve the right to make changes, corrections, modifications or improvements, to this document, and the products and services described herein at any time, without notice.

All ST products are sold pursuant to ST's terms and conditions of sale.

Purchasers are solely responsible for the choice, selection and use of the ST products and services described herein, and ST assumes no liability whatsoever relating to the choice, selection or use of the ST products and services described herein.

No license, express or implied, by estoppel or otherwise, to any intellectual property rights is granted under this document. If any part of this document refers to any third party products or services it shall not be deemed a license grant by ST for the use of such third party products or services, or any intellectual property contained therein or considered as a warranty covering the use in any manner whatsoever of such third party products or services or any intellectual property contained therein.

UNLESS OTHERWISE SET FORTH IN ST'S TERMS AND CONDITIONS OF SALE ST DISCLAIMS ANY EXPRESS OR IMPLIED WARRANTY WITH RESPECT TO THE USE AND/OR SALE OF ST PRODUCTS INCLUDING WITHOUT LIMITATION IMPLIED WARRANTIES OF MERCHANTABILITY, FITNESS FOR A PARTICULAR PURPOSE (AND THEIR EQUIVALENTS UNDER THE LAWS OF ANY JURISDICTION), OR INFRINGEMENT OF ANY PATENT, COPYRIGHT OR OTHER INTELLECTUAL PROPERTY RIGHT.

UNLESS EXPRESSLY APPROVED IN WRITING BY AN AUTHORIZED ST REPRESENTATIVE, ST PRODUCTS ARE NOT RECOMMENDED, AUTHORIZED OR WARRANTED FOR USE IN MILITARY, AIR CRAFT, SPACE, LIFE SAVING, OR LIFE SUSTAINING APPLICATIONS, NOR IN PRODUCTS OR SYSTEMS WHERE FAILURE OR MALFUNCTION MAY RESULT IN PERSONAL INJURY, DEATH, OR SEVERE PROPERTY OR ENVIRONMENTAL DAMAGE. ST PRODUCTS WHICH ARE NOT SPECIFIED AS "AUTOMOTIVE GRADE" MAY ONLY BE USED IN AUTOMOTIVE APPLICATIONS AT USER'S OWN RISK.

Resale of ST products with provisions different from the statements and/or technical features set forth in this document shall immediately void any warranty granted by ST for the ST product or service described herein and shall not create or extend in any manner whatsoever, any liability of ST.

ST and the ST logo are trademarks or registered trademarks of ST in various countries.

Information in this document supersedes and replaces all information previously supplied.

The ST logo is a registered trademark of STMicroelectronics. All other names are the property of their respective owners.

© 2009 STMicroelectronics - All rights reserved

STMicroelectronics group of companies

Australia - Belgium - Brazil - Canada - China - Czech Republic - Finland - France - Germany - Hong Kong - India - Israel - Italy - Japan - Malaysia - Malta - Morocco - Singapore - Spain - Sweden - Switzerland - United Kingdom - United States of America

www.st.com