

Distributed by:

**JAMECO**<sup>®</sup>  
ELECTRONICS

**www.Jameco.com ♦ 1-800-831-4242**

The content and copyrights of the attached  
material are the property of its owner.

Jameco Part Number 1147063

# ULN2001A, ULN2002A, ULN2003A, ULN2004A, ULQ2003A, ULQ2004A HIGH-VOLTAGE HIGH-CURRENT DARLINGTON TRANSISTOR ARRAY

SLRS027G – DECEMBER 1976 – REVISED JUNE 2004

The ULN2001A is obsolete  
and is no longer supplied.

- 500-mA-Rated Collector Current (Single Output)
- High-Voltage Outputs . . . 50 V
- Output Clamp Diodes
- Inputs Compatible With Various Types of Logic
- Relay-Driver Applications

ULN2001A . . . D OR N PACKAGE  
ULN2002A . . . N PACKAGE  
ULN2003A . . . D, N, NS, OR PW PACKAGE  
ULN2004A . . . D, N, OR NS PACKAGE  
ULQ2003A, ULQ2004A . . . D OR N PACKAGE  
(TOP VIEW)

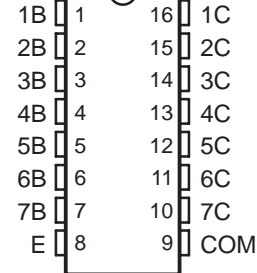

## description/ordering information

The ULN2001A, ULN2002A, ULN2003A, ULN2004A, ULQ2003A, and ULQ2004A are high-voltage, high-current Darlington transistor arrays. Each consists of seven npn Darlington pairs that feature high-voltage outputs with common-cathode clamp diodes for switching inductive loads. The collector-current rating of a single Darlington pair is 500 mA. The Darlington pairs can be paralleled for higher current capability. Applications include relay drivers, hammer drivers, lamp drivers, display drivers (LED and gas discharge), line drivers, and logic buffers. For 100-V (otherwise interchangeable) versions of the ULN2003A and ULN2004A, see the SN75468 and SN75469, respectively.

## ORDERING INFORMATION

T <sub>A</sub>	PACKAGE†		ORDERABLE PART NUMBER	TOP-SIDE MARKING
-20°C to 70°C	PDIP (N)	Tube of 25	ULN2002AN	ULN2002AN
			ULN2003AN	ULN2003AN
			ULN2004AN	ULN2004AN
	SOIC (D)	Tube of 40	ULN2003AD	ULN2003A
			ULN2003ADR	
		Reel of 2500	ULN2004AD	ULN2004A
			ULN2004ADR	
	SOP (NS)	Reel of 2000	ULN2003ANSR	ULN2003A
			ULN2004ANSR	ULN2004A
	TSSOP (PW)	Tube of 90	ULN2003APW	UN2003A
Reel of 2000			ULN2003APWR	
-40°C to 85°C	PDIP (N)	Tube of 25	ULQ2003AN	ULQ2003A
			ULQ2004AN	ULQ2004AN
	SOIC (D)	Tube of 40	ULQ2003AD	ULQ2003A
			ULQ2003ADR	
		Reel of 2500	ULQ2004AD	ULQ2004A
			ULQ2004ADR	

† Package drawings, standard packing quantities, thermal data, symbolization, and PCB design guidelines are available at [www.ti.com/sc/package](http://www.ti.com/sc/package).



Please be aware that an important notice concerning availability, standard warranty, and use in critical applications of Texas Instruments semiconductor products and disclaimers thereto appears at the end of this data sheet.

PRODUCTION DATA information is current as of publication date. Products conform to specifications per the terms of Texas Instruments standard warranty. Production processing does not necessarily include testing of all parameters.

 **TEXAS  
INSTRUMENTS**

POST OFFICE BOX 655303 • DALLAS, TEXAS 75265

Copyright © 2004, Texas Instruments Incorporated  
On products compliant to MIL-PRF-38535, all parameters are tested unless otherwise noted. On all other products, production processing does not necessarily include testing of all parameters.

# ULN2001A, ULN2002A, ULN2003A, ULN2004A, ULQ2003A, ULQ2004A HIGH-VOLTAGE HIGH-CURRENT DARLINGTON TRANSISTOR ARRAY

SLRS027G – DECEMBER 1976 – REVISED JUNE 2004

The ULN2001A is obsolete  
and is no longer supplied.

## description/ordering information (continued)

The ULN2001A is a general-purpose array and can be used with TTL and CMOS technologies. The ULN2002A is designed specifically for use with 14-V to 25-V PMOS devices. Each input of this device has a Zener diode and resistor in series to control the input current to a safe limit. The ULN2003A and ULQ2003A have a 2.7-k $\Omega$  series base resistor for each Darlington pair for operation directly with TTL or 5-V CMOS devices. The ULN2004A and ULQ2004A have a 10.5-k $\Omega$  series base resistor to allow operation directly from CMOS devices that use supply voltages of 6 V to 15 V. The required input current of the ULN/ULQ2004A is below that of the ULN/ULQ2003A, and the required voltage is less than that required by the ULN2002A.

## logic diagram

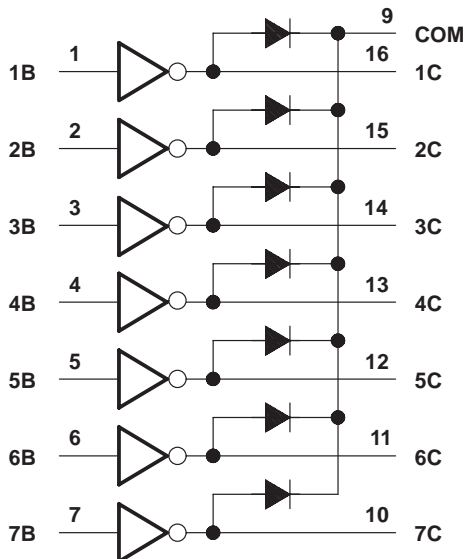

The ULN2001A is obsolete  
and is no longer supplied.

schematics (each Darlington pair)

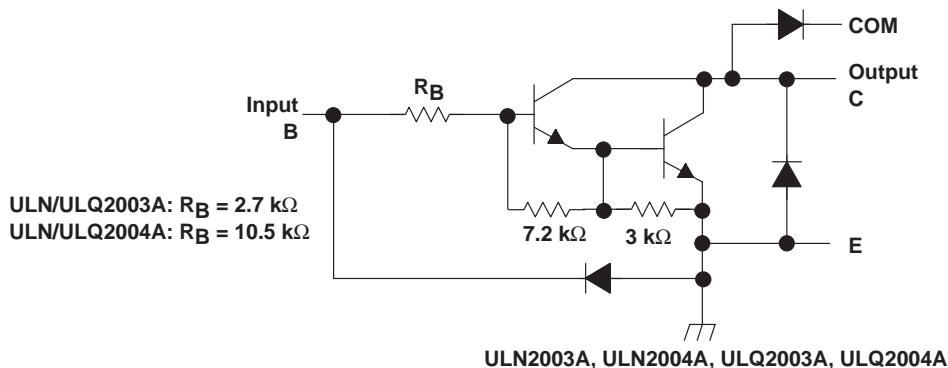
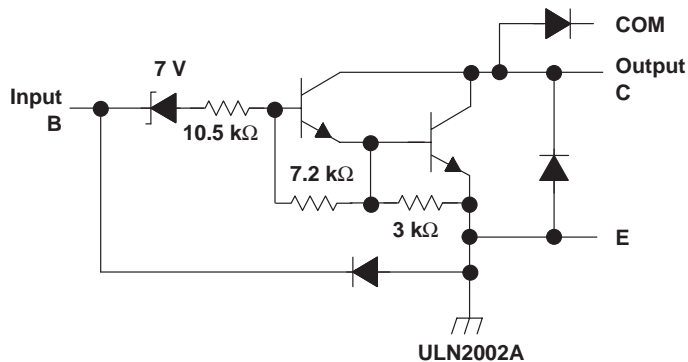
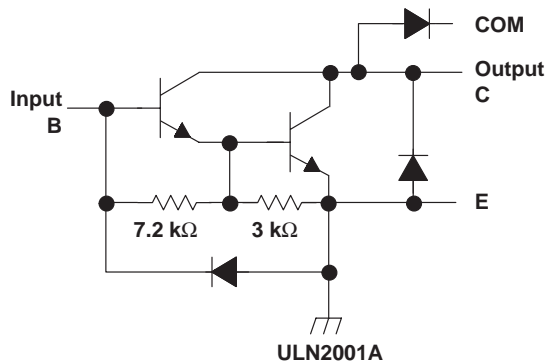

All resistor values shown are nominal.

# ULN2001A, ULN2002A, ULN2003A, ULN2004A, ULQ2003A, ULQ2004A HIGH-VOLTAGE HIGH-CURRENT DARLINGTON TRANSISTOR ARRAY

SLRS027G – DECEMBER 1976 – REVISED JUNE 2004

The ULN2001A is obsolete  
and is no longer supplied.

## absolute maximum ratings at 25°C free-air temperature (unless otherwise noted)†

Collector-emitter voltage	50 V
Clamp diode reverse voltage (see Note 1)	50 V
Input voltage, $V_I$ (see Note 1)	30 V
Peak collector current (see Figures 14 and 15)	500 mA
Output clamp current, $I_{OK}$	500 mA
Total emitter-terminal current	-2.5 A
Operating free-air temperature range, $T_A$ , ULN200xA	-20°C to 70°C
ULQ200xA	-40°C to 85°C
ULQ200xAT	-40°C to 105°C
Package thermal impedance, $\theta_{JA}$ (see Notes 2 and 3): D package	73°C/W
N package	67°C/W
NS package	64°C/W
PW package	108°C/W
Package thermal impedance, $\theta_{JC}$ (see Notes 4 and 5): D package	36°C/W
N package	54°C/W
Operating virtual junction temperature, $T_J$	150°C
Lead temperature 1,6 mm (1/16 inch) from case for 10 seconds	260°C
Storage temperature range, $T_{stg}$	-65°C to 150°C

† Stresses beyond those listed under “absolute maximum ratings” may cause permanent damage to the device. These are stress ratings only, and functional operation of the device at these or any other conditions beyond those indicated under “recommended operating conditions” is not implied. Exposure to absolute-maximum-rated conditions for extended periods may affect device reliability.

- NOTES:
- All voltage values are with respect to the emitter/substrate terminal E, unless otherwise noted.
  - Maximum power dissipation is a function of  $T_J(\text{max})$ ,  $\theta_{JA}$ , and  $T_A$ . The maximum allowable power dissipation at any allowable ambient temperature is  $P_D = (T_J(\text{max}) - T_A)/\theta_{JA}$ . Operating at the absolute maximum  $T_J$  of 150°C can affect reliability.
  - The package thermal impedance is calculated in accordance with JEDEC 51-7.
  - Maximum power dissipation is a function of  $T_J(\text{max})$ ,  $\theta_{JC}$ , and  $T_C$ . The maximum allowable power dissipation at any allowable case temperature is  $P_D = (T_J(\text{max}) - T_C)/\theta_{JC}$ . Operating at the absolute maximum  $T_J$  of 150°C can affect reliability.
  - The package thermal impedance is calculated in accordance with MIL-STD-883.

## electrical characteristics, $T_A = 25^\circ\text{C}$ (unless otherwise noted)

PARAMETER	TEST FIGURE	TEST CONDITIONS	ULN2001A			ULN2002A			UNIT
			MIN	TYP	MAX	MIN	TYP	MAX	
$V_{I(\text{on})}$ On-state input voltage	6	$V_{CE} = 2\text{ V}$ , $I_C = 300\text{ mA}$						13	V
$V_{CE(\text{sat})}$ Collector-emitter saturation voltage	5	$I_I = 250\ \mu\text{A}$ , $I_C = 100\text{ mA}$	0.9	1.1	0.9	1.1			V
		$I_I = 350\ \mu\text{A}$ , $I_C = 200\text{ mA}$	1	1.3	1	1.3			
		$I_I = 500\ \mu\text{A}$ , $I_C = 350\text{ mA}$	1.2	1.6	1.2	1.6			
$V_F$ Clamp forward voltage	8	$I_F = 350\text{ mA}$	1.7	2	1.7	2		V	
$I_{CEX}$ Collector cutoff current	1	$V_{CE} = 50\text{ V}$ , $I_I = 0$		50		50			$\mu\text{A}$
	2	$V_{CE} = 50\text{ V}$ , $T_A = 70^\circ\text{C}$ , $I_I = 0$ , $V_I = 6\text{ V}$		100		100	500		
$I_{I(\text{off})}$ Off-state input current	3	$V_{CE} = 50\text{ V}$ , $T_A = 70^\circ\text{C}$ , $I_C = 500\ \mu\text{A}$	50	65	50	65		$\mu\text{A}$	
$I_I$ Input current	4	$V_I = 17\text{ V}$				0.82	1.25	mA	
$I_R$ Clamp reverse current	7	$V_R = 50\text{ V}$ , $T_A = 70^\circ\text{C}$		100		100		$\mu\text{A}$	
		$V_R = 50\text{ V}$		50		50			
$h_{FE}$ Static forward-current transfer ratio	5	$V_{CE} = 2\text{ V}$ , $I_C = 350\text{ mA}$	1000						
$C_i$ Input capacitance		$V_I = 0$ , $f = 1\text{ MHz}$	15	25	15	25		pF	



The ULN2001A is obsolete  
and is no longer supplied.

electrical characteristics,  $T_A = 25^\circ\text{C}$  (unless otherwise noted) (continued)

PARAMETER	TEST FIGURE	TEST CONDITIONS		ULN2003A			ULN2004A			UNIT
				MIN	TYP	MAX	MIN	TYP	MAX	
$V_{I(on)}$ On-state input voltage	6	$V_{CE} = 2\text{ V}$	$I_C = 125\text{ mA}$						5	V
			$I_C = 200\text{ mA}$			2.4			6	
			$I_C = 250\text{ mA}$			2.7				
			$I_C = 275\text{ mA}$						7	
			$I_C = 300\text{ mA}$			3				
			$I_C = 350\text{ mA}$						8	
$V_{CE(sat)}$ Collector-emitter saturation voltage	5	$I_I = 250\ \mu\text{A}$ , $I_C = 100\text{ mA}$	0.9	1.1	0.9	1.1			V	
		$I_I = 350\ \mu\text{A}$ , $I_C = 200\text{ mA}$	1	1.3	1	1.3				
		$I_I = 500\ \mu\text{A}$ , $I_C = 350\text{ mA}$	1.2	1.6	1.2	1.6				
$I_{CEX}$ Collector cutoff current	1	$V_{CE} = 50\text{ V}$ , $I_I = 0$		50		50			$\mu\text{A}$	
	2	$V_{CE} = 50\text{ V}$ , $T_A = 70^\circ\text{C}$ , $V_I = 1\text{ V}$		100		100		500		
$V_F$ Clamp forward voltage	8	$I_F = 350\text{ mA}$	1.7	2	1.7	2			V	
$I_{I(off)}$ Off-state input current	3	$V_{CE} = 50\text{ V}$ , $T_A = 70^\circ\text{C}$ , $I_C = 500\ \mu\text{A}$	50	65	50	65			$\mu\text{A}$	
$I_I$ Input current	4	$V_I = 3.85\text{ V}$	0.93	1.35					mA	
		$V_I = 5\text{ V}$			0.35	0.5				
		$V_I = 12\text{ V}$			1	1.45				
$I_R$ Clamp reverse current	7	$V_R = 50\text{ V}$		50		50			$\mu\text{A}$	
		$V_R = 50\text{ V}$ , $T_A = 70^\circ\text{C}$		100		100				
$C_i$ Input capacitance		$V_I = 0$ , $f = 1\text{ MHz}$	15	25	15	25			pF	

**ULN2001A, ULN2002A, ULN2003A, ULN2004A, ULQ2003A, ULQ2004A**  
**HIGH-VOLTAGE HIGH-CURRENT**  
**DARLINGTON TRANSISTOR ARRAY**

SLRS027G – DECEMBER 1976 – REVISED JUNE 2004

The ULN2001A is obsolete  
and is no longer supplied.

**electrical characteristics over recommended operating conditions (unless otherwise noted)**

PARAMETER	TEST FIGURE	TEST CONDITIONS		ULQ2003A			ULQ2004A			UNIT
				MIN	TYP	MAX	MIN	TYP	MAX	
$V_{I(on)}$ On-state input voltage	6	$V_{CE} = 2\text{ V}$	$I_C = 125\text{ mA}$						5	V
			$I_C = 200\text{ mA}$						6	
			$I_C = 250\text{ mA}$						2.7	
			$I_C = 275\text{ mA}$						2.9	
			$I_C = 300\text{ mA}$						3	
			$I_C = 350\text{ mA}$						7	
$V_{CE(sat)}$ Collector-emitter saturation voltage	5		$I_I = 250\text{ }\mu\text{A}$ , $I_C = 100\text{ mA}$	0.9	1.2		0.9	1.1	V	
			$I_I = 350\text{ }\mu\text{A}$ , $I_C = 200\text{ mA}$	1	1.4		1	1.3		
			$I_I = 500\text{ }\mu\text{A}$ , $I_C = 350\text{ mA}$	1.2	1.7		1.2	1.6		
$I_{CEX}$ Collector cutoff current	1	$V_{CE} = 50\text{ V}$ , $I_I = 0$						100	$\mu\text{A}$	
	2	$V_{CE} = 50\text{ V}$	$I_I = 0$					500		
$V_F$ Clamp forward voltage	8	$I_F = 350\text{ mA}$		1.7	2.3		1.7	2	V	
$I_{I(off)}$ Off-state input current	3	$V_{CE} = 50\text{ V}$ , $I_C = 500\text{ }\mu\text{A}$		65		50	65		$\mu\text{A}$	
$I_I$ Input current	4		$V_I = 3.85\text{ V}$	0.93	1.35				mA	
			$V_I = 5\text{ V}$				0.35	0.5		
			$V_I = 12\text{ V}$				1	1.45		
$I_R$ Clamp reverse current	7	$V_R = 50\text{ V}$ , $T_A = 25^\circ\text{C}$			100			50	$\mu\text{A}$	
			$V_R = 50\text{ V}$			100				100
$C_i$ Input capacitance		$V_I = 0$ , $f = 1\text{ MHz}$		15	25		15	25	pF	

**switching characteristics,  $T_A = 25^\circ\text{C}$**

PARAMETER	TEST CONDITIONS	ULN2001A, ULN2002A, ULN2003A, ULN2004A			UNIT
		MIN	TYP	MAX	
$t_{PLH}$ Propagation delay time, low- to high-level output	See Figure 9		0.25	1	$\mu\text{s}$
$t_{PHL}$ Propagation delay time, high- to low-level output	See Figure 9		0.25	1	$\mu\text{s}$
$V_{OH}$ High-level output voltage after switching	$V_S = 50\text{ V}$ , $I_O \approx 300\text{ mA}$ , See Figure 10		$V_S - 20$		mV

**switching characteristics over recommended operating conditions (unless otherwise noted)**

PARAMETER	TEST CONDITIONS	ULQ2003A, ULQ2004A			UNIT
		MIN	TYP	MAX	
$t_{PLH}$ Propagation delay time, low- to high-level output	See Figure 9		1	10	$\mu\text{s}$
$t_{PHL}$ Propagation delay time, high- to low-level output	See Figure 9		1	10	$\mu\text{s}$
$V_{OH}$ High-level output voltage after switching	$V_S = 50\text{ V}$ , $I_O \approx 300\text{ mA}$ , See Figure 10		$V_S - 500$		mV



The ULN2001A is obsolete and is no longer supplied.

PARAMETER MEASUREMENT INFORMATION

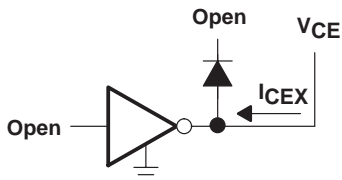

Figure 1.  $I_{CEX}$  Test Circuit

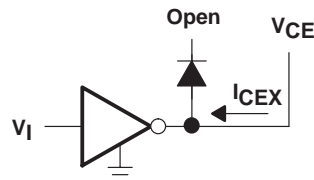

Figure 2.  $I_{CEX}$  Test Circuit

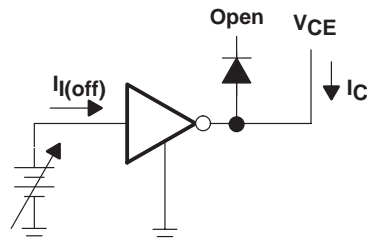

Figure 3.  $I_{I(off)}$  Test Circuit

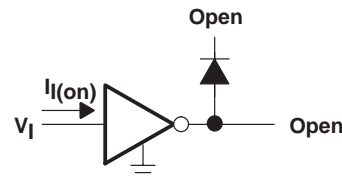
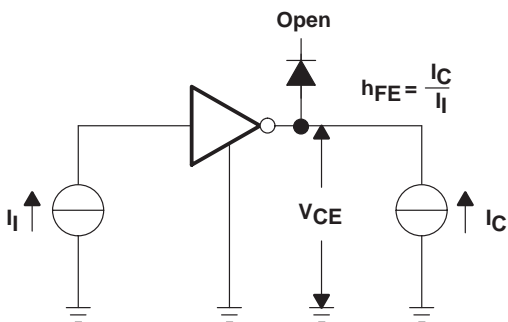

Figure 4.  $I_I$  Test Circuit



NOTE:  $I_I$  is fixed for measuring  $V_{CE(sat)}$ , variable for measuring  $h_{FE}$ .

Figure 5.  $h_{FE}$ ,  $V_{CE(sat)}$  Test Circuit

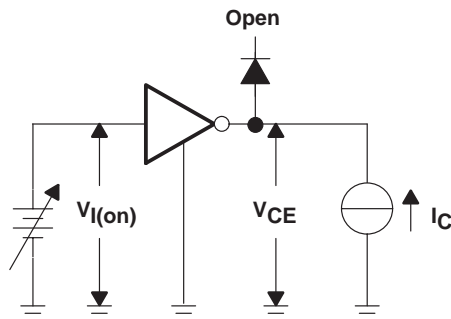

Figure 6.  $V_{I(on)}$  Test Circuit

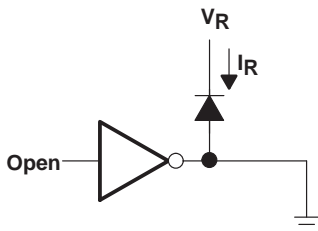

Figure 7.  $I_R$  Test Circuit

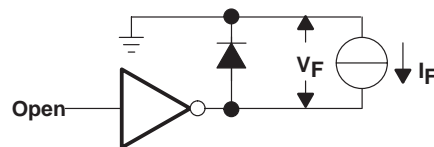

Figure 8.  $V_F$  Test Circuit

**ULN2001A, ULN2002A, ULN2003A, ULN2004A, ULQ2003A, ULQ2004A**  
**HIGH-VOLTAGE HIGH-CURRENT**  
**DARLINGTON TRANSISTOR ARRAY**

SLRS027G – DECEMBER 1976 – REVISED JUNE 2004

The ULN2001A is obsolete  
 and is no longer supplied.

**PARAMETER MEASUREMENT INFORMATION**

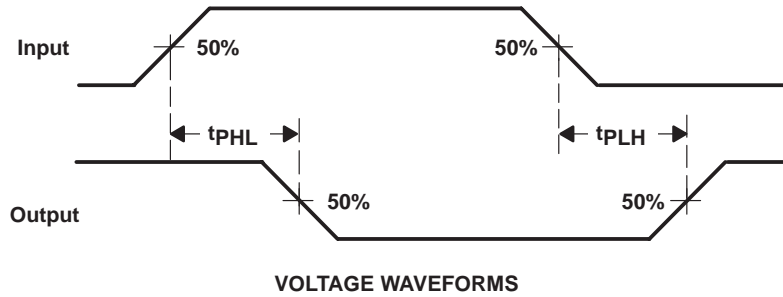

**Figure 9. Propagation Delay-Time Waveforms**

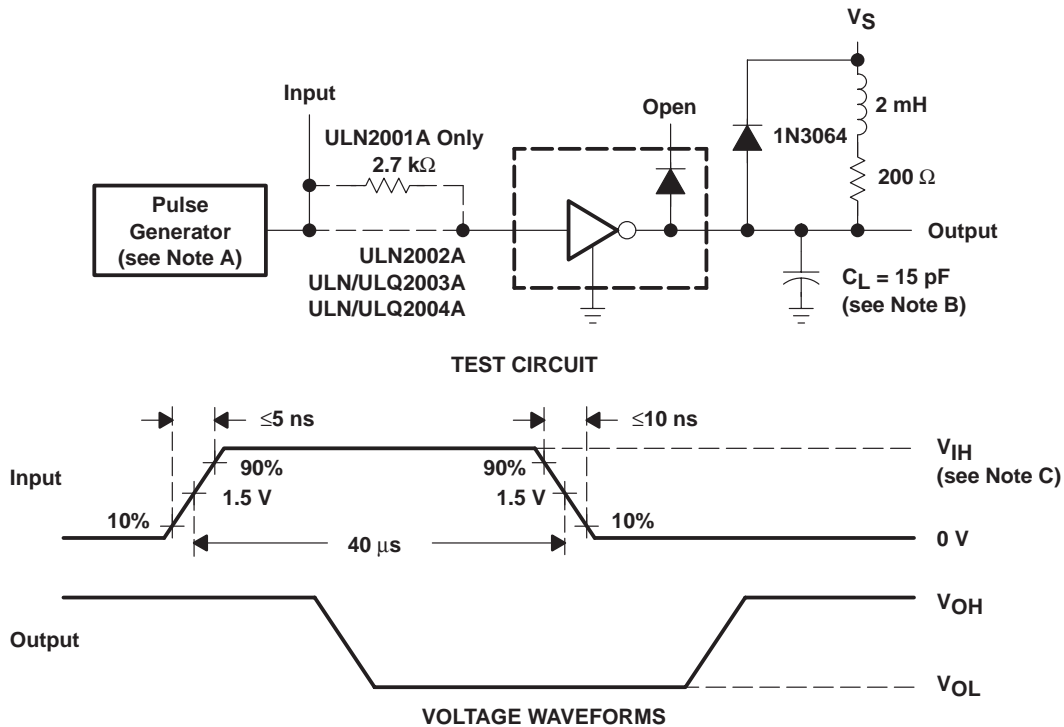

- NOTES: A. The pulse generator has the following characteristics: PRR = 12.5 kHz,  $Z_O = 50 \Omega$ .  
 B.  $C_L$  includes probe and jig capacitance.  
 C. For testing the ULN2001A, the ULN2003A, and the ULQ2003A,  $V_{IH} = 3 \text{ V}$ ; for the ULN2002A,  $V_{IH} = 13 \text{ V}$ ; for the ULN2004A and the ULQ2004A,  $V_{IH} = 8 \text{ V}$ .

**Figure 10. Latch-Up Test Circuit and Voltage Waveforms**

The ULN2001A is obsolete and is no longer supplied.

**TYPICAL CHARACTERISTICS**

**COLLECTOR-EMITTER SATURATION VOLTAGE vs COLLECTOR CURRENT (ONE DARLINGTON)**

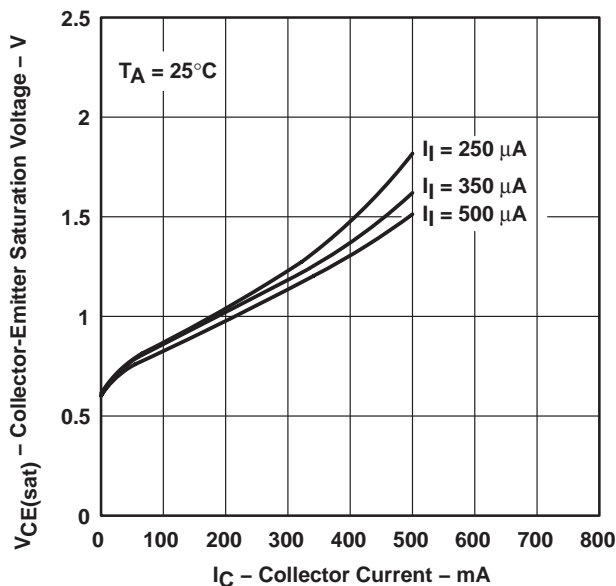

**Figure 11**

**COLLECTOR-EMITTER SATURATION VOLTAGE vs TOTAL COLLECTOR CURRENT (TWO DARLINGTONS IN PARALLEL)**

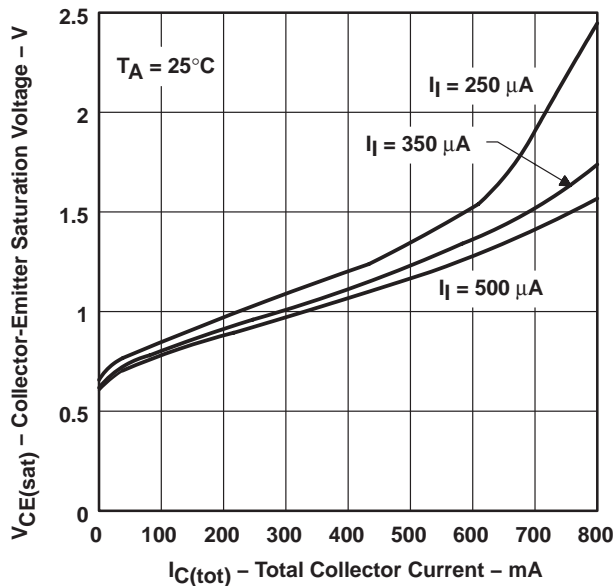

**Figure 12**

**COLLECTOR CURRENT vs INPUT CURRENT**

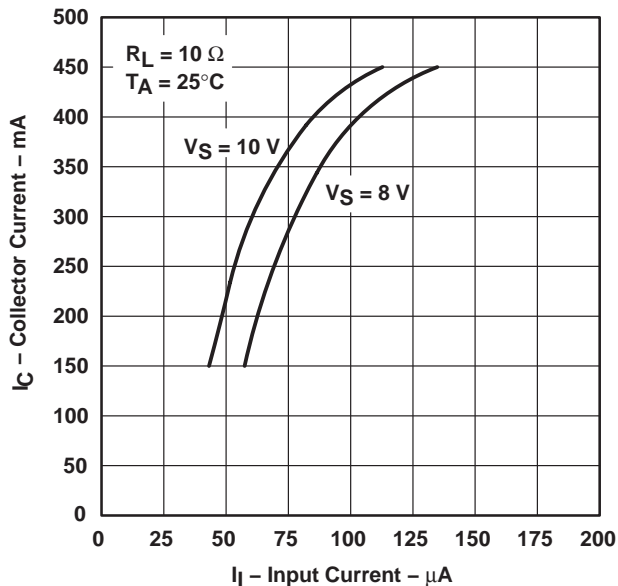

**Figure 13**

**ULN2001A, ULN2002A, ULN2003A, ULN2004A, ULQ2003A, ULQ2004A**  
**HIGH-VOLTAGE HIGH-CURRENT**  
**DARLINGTON TRANSISTOR ARRAY**

SLRS027G – DECEMBER 1976 – REVISED JUNE 2004

The ULN2001A is obsolete  
 and is no longer supplied.

**THERMAL INFORMATION**

**D PACKAGE**  
**MAXIMUM COLLECTOR CURRENT**  
**vs**  
**DUTY CYCLE**

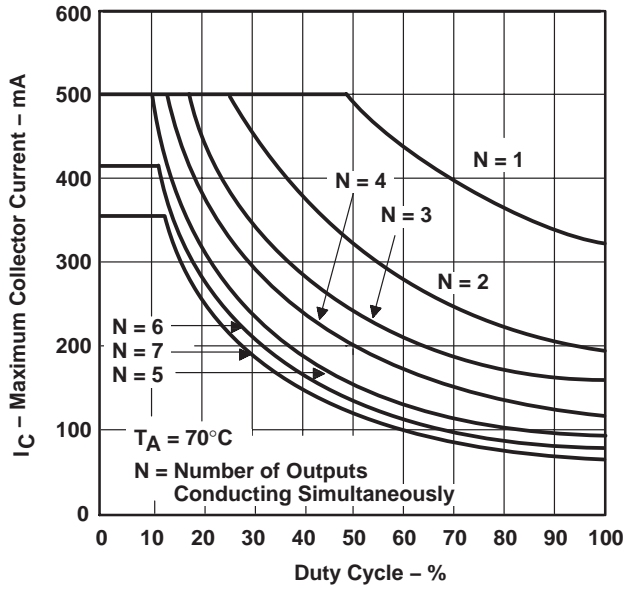

**Figure 14**

**N PACKAGE**  
**MAXIMUM COLLECTOR CURRENT**  
**vs**  
**DUTY CYCLE**

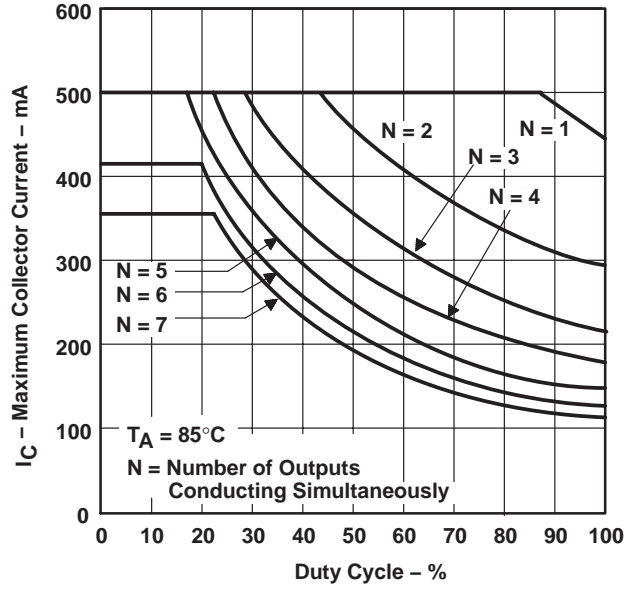

**Figure 15**

The ULN2001A is obsolete and is no longer supplied.

**APPLICATION INFORMATION**

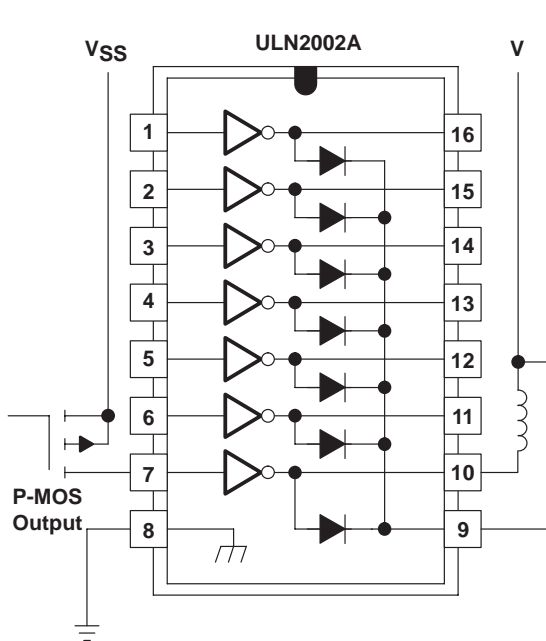

**Figure 16. P-MOS to Load**

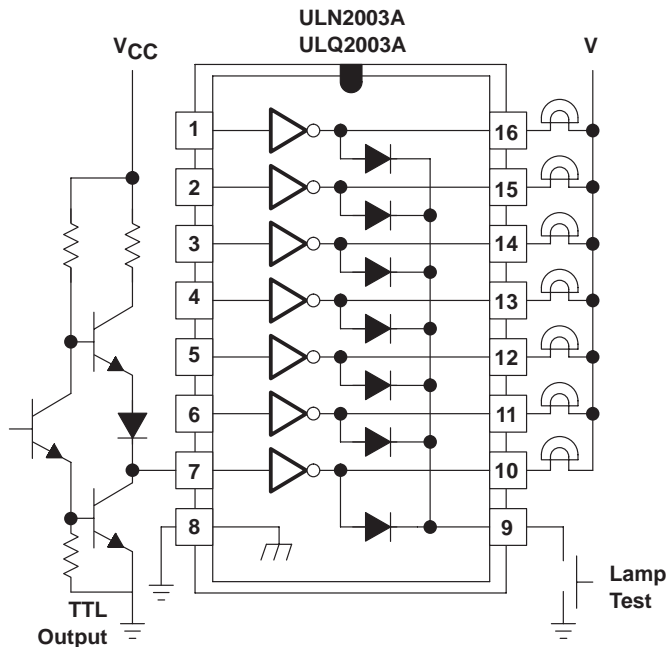

**Figure 17. TTL to Load**

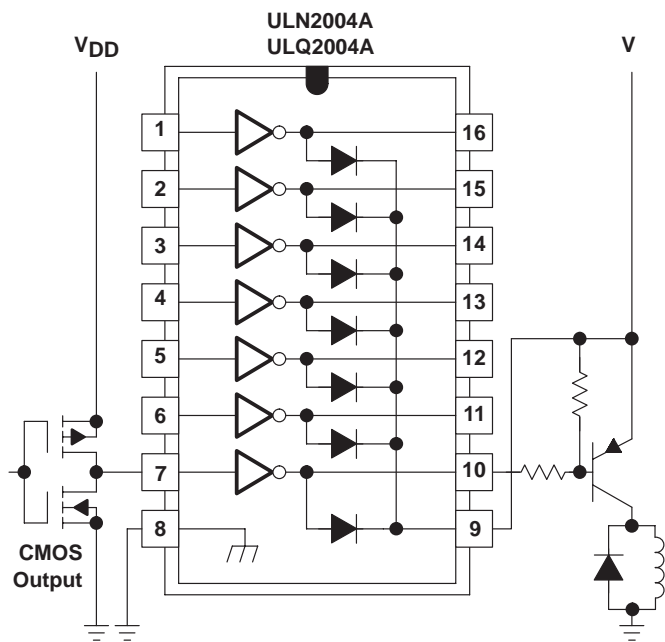

**Figure 18. Buffer for Higher Current Loads**

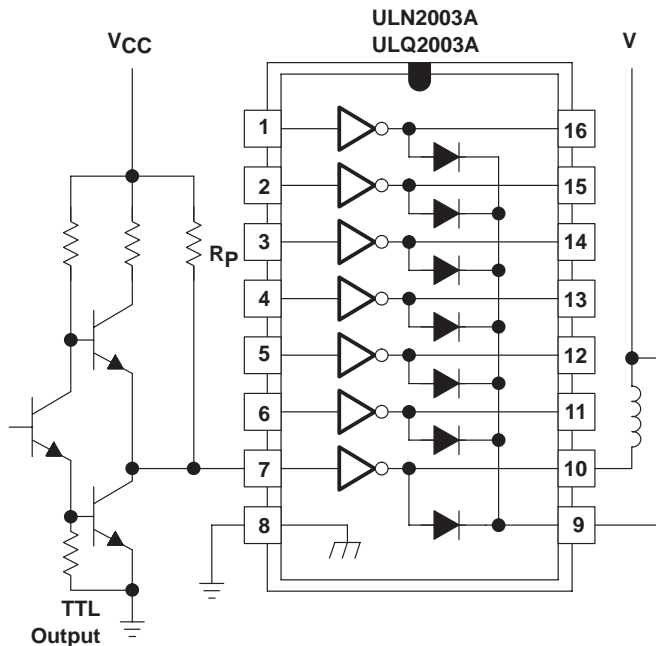

**Figure 19. Use of Pullup Resistors to Increase Drive Current**

**PACKAGING INFORMATION**

Orderable Device	Status <sup>(1)</sup>	Package Type	Package Drawing	Pins	Package Qty	Eco Plan <sup>(2)</sup>	Lead/Ball Finish	MSL Peak Temp <sup>(3)</sup>
ULN2001AD	OBSOLETE	SOIC	D	16		TBD	Call TI	Call TI
ULN2001ADR	OBSOLETE	SOIC	D	16		TBD	Call TI	Call TI
ULN2001AN	OBSOLETE	PDIP	N	16		TBD	Call TI	Call TI
ULN2002AD	OBSOLETE	SOIC	D	16		TBD	Call TI	Call TI
ULN2002AN	ACTIVE	PDIP	N	16	25	Pb-Free (RoHS)	CU NIPDAU	N / A for Pkg Type
ULN2002ANE4	ACTIVE	PDIP	N	16	25	Pb-Free (RoHS)	CU NIPDAU	N / A for Pkg Type
ULN2003AD	ACTIVE	SOIC	D	16	40	Green (RoHS & no Sb/Br)	CU NIPDAU	Level-1-260C-UNLIM
ULN2003ADE4	ACTIVE	SOIC	D	16	40	Green (RoHS & no Sb/Br)	CU NIPDAU	Level-1-260C-UNLIM
ULN2003ADG4	ACTIVE	SOIC	D	16	40	Green (RoHS & no Sb/Br)	CU NIPDAU	Level-1-260C-UNLIM
ULN2003ADR	ACTIVE	SOIC	D	16	2500	Green (RoHS & no Sb/Br)	CU NIPDAU	Level-1-260C-UNLIM
ULN2003ADRE4	ACTIVE	SOIC	D	16	2500	Green (RoHS & no Sb/Br)	CU NIPDAU	Level-1-260C-UNLIM
ULN2003ADRG4	ACTIVE	SOIC	D	16	2500	Green (RoHS & no Sb/Br)	CU NIPDAU	Level-1-260C-UNLIM
ULN2003AJ	OBSOLETE	CDIP	J	16		TBD	Call TI	Call TI
ULN2003AN	ACTIVE	PDIP	N	16	25	Pb-Free (RoHS)	CU NIPDAU	N / A for Pkg Type
ULN2003ANE4	ACTIVE	PDIP	N	16	25	Pb-Free (RoHS)	CU NIPDAU	N / A for Pkg Type
ULN2003ANSR	ACTIVE	SO	NS	16	2000	Green (RoHS & no Sb/Br)	CU NIPDAU	Level-1-260C-UNLIM
ULN2003ANSRE4	ACTIVE	SO	NS	16	2000	Green (RoHS & no Sb/Br)	CU NIPDAU	Level-1-260C-UNLIM
ULN2003ANSRG4	ACTIVE	SO	NS	16	2000	Green (RoHS & no Sb/Br)	CU NIPDAU	Level-1-260C-UNLIM
ULN2003APW	ACTIVE	TSSOP	PW	16	90	Green (RoHS & no Sb/Br)	CU NIPDAU	Level-1-260C-UNLIM
ULN2003APWE4	ACTIVE	TSSOP	PW	16	90	Green (RoHS & no Sb/Br)	CU NIPDAU	Level-1-260C-UNLIM
ULN2003APWG4	ACTIVE	TSSOP	PW	16	90	Green (RoHS & no Sb/Br)	CU NIPDAU	Level-1-260C-UNLIM
ULN2003APWR	ACTIVE	TSSOP	PW	16	2000	Green (RoHS & no Sb/Br)	CU NIPDAU	Level-1-260C-UNLIM
ULN2003APWRE4	ACTIVE	TSSOP	PW	16	2000	Green (RoHS & no Sb/Br)	CU NIPDAU	Level-1-260C-UNLIM
ULN2003APWRG4	ACTIVE	TSSOP	PW	16	2000	Green (RoHS & no Sb/Br)	CU NIPDAU	Level-1-260C-UNLIM
ULN2004AD	ACTIVE	SOIC	D	16	40	Green (RoHS & no Sb/Br)	CU NIPDAU	Level-1-260C-UNLIM
ULN2004ADE4	ACTIVE	SOIC	D	16	40	Green (RoHS & no Sb/Br)	CU NIPDAU	Level-1-260C-UNLIM
ULN2004ADG4	ACTIVE	SOIC	D	16	40	Green (RoHS & no Sb/Br)	CU NIPDAU	Level-1-260C-UNLIM

Orderable Device	Status <sup>(1)</sup>	Package Type	Package Drawing	Pins	Package Qty	Eco Plan <sup>(2)</sup>	Lead/Ball Finish	MSL Peak Temp <sup>(3)</sup>
ULN2004ADR	ACTIVE	SOIC	D	16	2500	Green (RoHS & no Sb/Br)	CU NIPDAU	Level-1-260C-UNLIM
ULN2004ADRE4	ACTIVE	SOIC	D	16	2500	Green (RoHS & no Sb/Br)	CU NIPDAU	Level-1-260C-UNLIM
ULN2004ADRG4	ACTIVE	SOIC	D	16	2500	Green (RoHS & no Sb/Br)	CU NIPDAU	Level-1-260C-UNLIM
ULN2004AN	ACTIVE	PDIP	N	16	25	Pb-Free (RoHS)	CU NIPDAU	N / A for Pkg Type
ULN2004ANE4	ACTIVE	PDIP	N	16	25	Pb-Free (RoHS)	CU NIPDAU	N / A for Pkg Type
ULN2004ANSR	ACTIVE	SO	NS	16	2000	Green (RoHS & no Sb/Br)	CU NIPDAU	Level-1-260C-UNLIM
ULN2004ANSRG4	ACTIVE	SO	NS	16	2000	Green (RoHS & no Sb/Br)	CU NIPDAU	Level-1-260C-UNLIM
ULQ2003AD	ACTIVE	SOIC	D	16	40	Pb-Free (RoHS)	CU NIPDAU	Level-2-250C-1 YEAR/ Level-1-235C-UNLIM
ULQ2003ADG4	ACTIVE	SOIC	D	16	40	Green (RoHS & no Sb/Br)	CU NIPDAU	Level-1-260C-UNLIM
ULQ2003ADR	ACTIVE	SOIC	D	16	2500	Pb-Free (RoHS)	CU NIPDAU	Level-2-250C-1 YEAR/ Level-1-235C-UNLIM
ULQ2003ADRG4	ACTIVE	SOIC	D	16	2500	Green (RoHS & no Sb/Br)	CU NIPDAU	Level-1-260C-UNLIM
ULQ2003AN	ACTIVE	PDIP	N	16	25	Pb-Free (RoHS)	CU NIPDAU	N / A for Pkg Type
ULQ2004AD	ACTIVE	SOIC	D	16	40	Pb-Free (RoHS)	CU NIPDAU	Level-2-250C-1 YEAR/ Level-1-235C-UNLIM
ULQ2004ADG4	ACTIVE	SOIC	D	16	40	Green (RoHS & no Sb/Br)	CU NIPDAU	Level-1-260C-UNLIM
ULQ2004ADR	ACTIVE	SOIC	D	16	2500	Pb-Free (RoHS)	CU NIPDAU	Level-2-250C-1 YEAR/ Level-1-235C-UNLIM
ULQ2004ADRG4	ACTIVE	SOIC	D	16	2500	Green (RoHS & no Sb/Br)	CU NIPDAU	Level-1-260C-UNLIM
ULQ2004AN	ACTIVE	PDIP	N	16	25	Pb-Free (RoHS)	CU NIPDAU	N / A for Pkg Type

<sup>(1)</sup> The marketing status values are defined as follows:

**ACTIVE:** Product device recommended for new designs.

**LIFEBUY:** TI has announced that the device will be discontinued, and a lifetime-buy period is in effect.

**NRND:** Not recommended for new designs. Device is in production to support existing customers, but TI does not recommend using this part in a new design.

**PREVIEW:** Device has been announced but is not in production. Samples may or may not be available.

**OBSOLETE:** TI has discontinued the production of the device.

<sup>(2)</sup> Eco Plan - The planned eco-friendly classification: Pb-Free (RoHS), Pb-Free (RoHS Exempt), or Green (RoHS & no Sb/Br) - please check <http://www.ti.com/productcontent> for the latest availability information and additional product content details.

**TBD:** The Pb-Free/Green conversion plan has not been defined.

**Pb-Free (RoHS):** TI's terms "Lead-Free" or "Pb-Free" mean semiconductor products that are compatible with the current RoHS requirements for all 6 substances, including the requirement that lead not exceed 0.1% by weight in homogeneous materials. Where designed to be soldered at high temperatures, TI Pb-Free products are suitable for use in specified lead-free processes.

**Pb-Free (RoHS Exempt):** This component has a RoHS exemption for either 1) lead-based flip-chip solder bumps used between the die and package, or 2) lead-based die adhesive used between the die and leadframe. The component is otherwise considered Pb-Free (RoHS compatible) as defined above.

**Green (RoHS & no Sb/Br):** TI defines "Green" to mean Pb-Free (RoHS compatible), and free of Bromine (Br) and Antimony (Sb) based flame retardants (Br or Sb do not exceed 0.1% by weight in homogeneous material)

<sup>(3)</sup> MSL, Peak Temp. -- The Moisture Sensitivity Level rating according to the JEDEC industry standard classifications, and peak solder temperature.

**Important Information and Disclaimer:**The information provided on this page represents TI's knowledge and belief as of the date that it is provided. TI bases its knowledge and belief on information provided by third parties, and makes no representation or warranty as to the accuracy of such information. Efforts are underway to better integrate information from third parties. TI has taken and continues to take reasonable steps to provide representative and accurate information but may not have conducted destructive testing or chemical analysis on incoming materials and chemicals. TI and TI suppliers consider certain information to be proprietary, and thus CAS numbers and other limited information may not be available for release.

In no event shall TI's liability arising out of such information exceed the total purchase price of the TI part(s) at issue in this document sold by TI to Customer on an annual basis.

**TAPE AND REEL INFORMATION**



**QUADRANT ASSIGNMENTS FOR PIN 1 ORIENTATION IN TAPE**

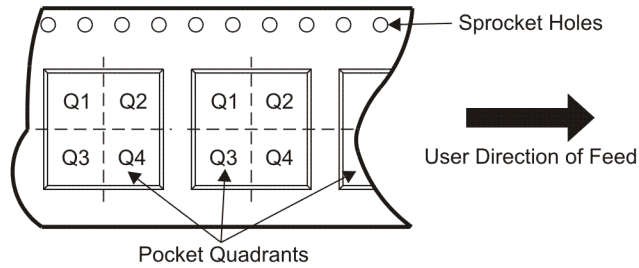

\*All dimensions are nominal

Device	Package Type	Package Drawing	Pins	SPQ	Reel Diameter (mm)	Reel Width W1 (mm)	A0 (mm)	B0 (mm)	K0 (mm)	P1 (mm)	W (mm)	Pin1 Quadrant
ULN2003ADR	SOIC	D	16	2500	330.0	16.4	6.5	10.3	2.1	8.0	16.0	Q1
ULN2003ADR	SOIC	D	16	2500	330.0	16.4	6.5	10.3	2.1	8.0	16.0	Q1
ULN2003ANSR	SO	NS	16	2000	330.0	16.4	8.2	10.5	2.5	12.0	16.0	Q1
ULN2003APWR	TSSOP	PW	16	2000	330.0	12.4	7.0	5.6	1.6	8.0	12.0	Q1
ULN2004ADR	SOIC	D	16	2500	330.0	16.4	6.5	10.3	2.1	8.0	16.0	Q1
ULN2004ADR	SOIC	D	16	2500	330.0	16.4	6.5	10.3	2.1	8.0	16.0	Q1
ULN2004ANSR	SO	NS	16	2000	330.0	16.4	8.2	10.5	2.5	12.0	16.0	Q1

**TAPE AND REEL BOX DIMENSIONS**

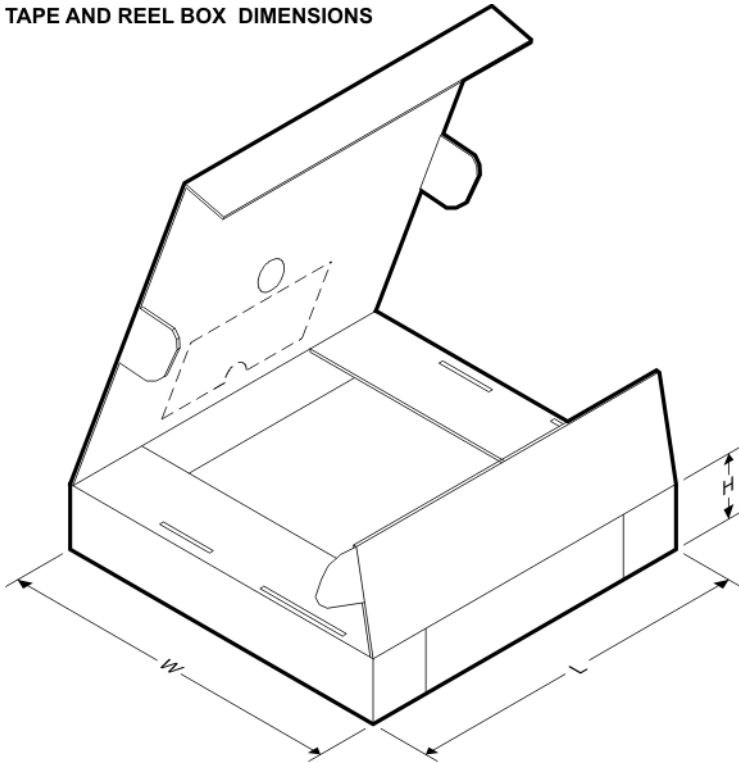

\*All dimensions are nominal

Device	Package Type	Package Drawing	Pins	SPQ	Length (mm)	Width (mm)	Height (mm)
ULN2003ADR	SOIC	D	16	2500	333.2	345.9	28.6
ULN2003ADR	SOIC	D	16	2500	346.0	346.0	33.0
ULN2003ANSR	SO	NS	16	2000	346.0	346.0	33.0
ULN2003APWR	TSSOP	PW	16	2000	346.0	346.0	29.0
ULN2004ADR	SOIC	D	16	2500	333.2	345.9	28.6
ULN2004ADR	SOIC	D	16	2500	346.0	346.0	33.0
ULN2004ANSR	SO	NS	16	2000	346.0	346.0	33.0

PW (R-PDSO-G\*\*)

PLASTIC SMALL-OUTLINE PACKAGE

14 PINS SHOWN



4040064/F 01/97

- NOTES: A. All linear dimensions are in millimeters.  
 B. This drawing is subject to change without notice.  
 C. Body dimensions do not include mold flash or protrusion not to exceed 0,15.  
 D. Falls within JEDEC MO-153

J (R-GDIP-T\*\*)

14 LEADS SHOWN

CERAMIC DUAL IN-LINE PACKAGE



DIM \ PINS **	14	16	18	20
A	0.300 (7,62) BSC	0.300 (7,62) BSC	0.300 (7,62) BSC	0.300 (7,62) BSC
B MAX	0.785 (19,94)	.840 (21,34)	0.960 (24,38)	1.060 (26,92)
B MIN	—	—	—	—
C MAX	0.300 (7,62)	0.300 (7,62)	0.310 (7,87)	0.300 (7,62)
C MIN	0.245 (6,22)	0.245 (6,22)	0.220 (5,59)	0.245 (6,22)



4040083/F 03/03

- NOTES:
- All linear dimensions are in inches (millimeters).
  - This drawing is subject to change without notice.
  - This package is hermetically sealed with a ceramic lid using glass frit.
  - Index point is provided on cap for terminal identification only on press ceramic glass frit seal only.
  - Falls within MIL STD 1835 GDIP1-T14, GDIP1-T16, GDIP1-T18 and GDIP1-T20.

## MECHANICAL DATA

NS (R-PDSO-G\*\*)

PLASTIC SMALL-OUTLINE PACKAGE

14-PINS SHOWN



- NOTES:
- A. All linear dimensions are in millimeters.
  - B. This drawing is subject to change without notice.
  - C. Body dimensions do not include mold flash or protrusion, not to exceed 0,15.

D (R-PDSO-G16)

PLASTIC SMALL-OUTLINE PACKAGE

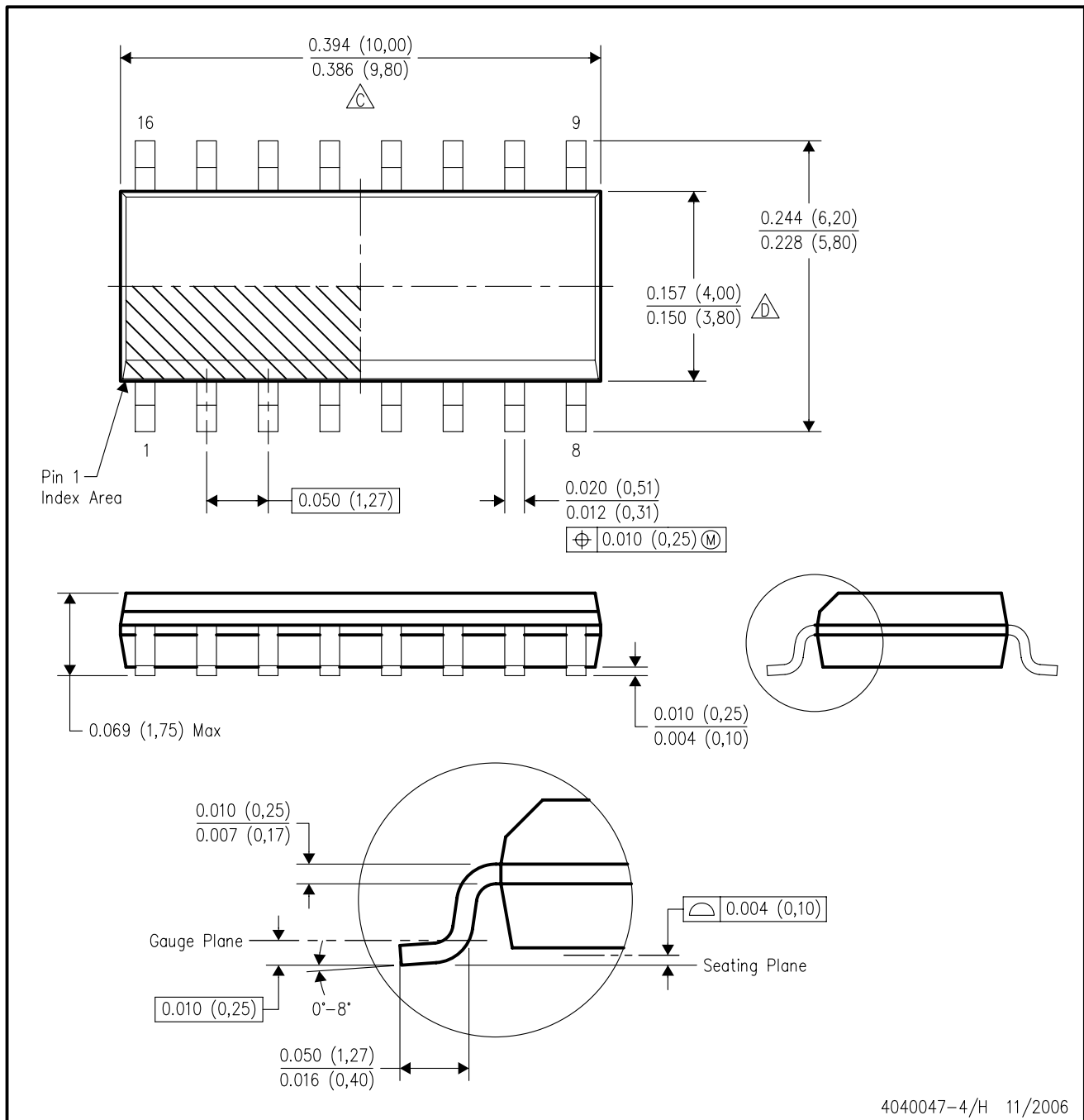

- NOTES:
- A. All linear dimensions are in inches (millimeters).
  - B. This drawing is subject to change without notice.
  - C. Body length does not include mold flash, protrusions, or gate burrs. Mold flash, protrusions, or gate burrs shall not exceed .006 (0,15) per end.
  - D. Body width does not include interlead flash. Interlead flash shall not exceed .017 (0,43) per side.
  - E. Reference JEDEC MS-012 variation AC.

D(R-PDSO-G16)

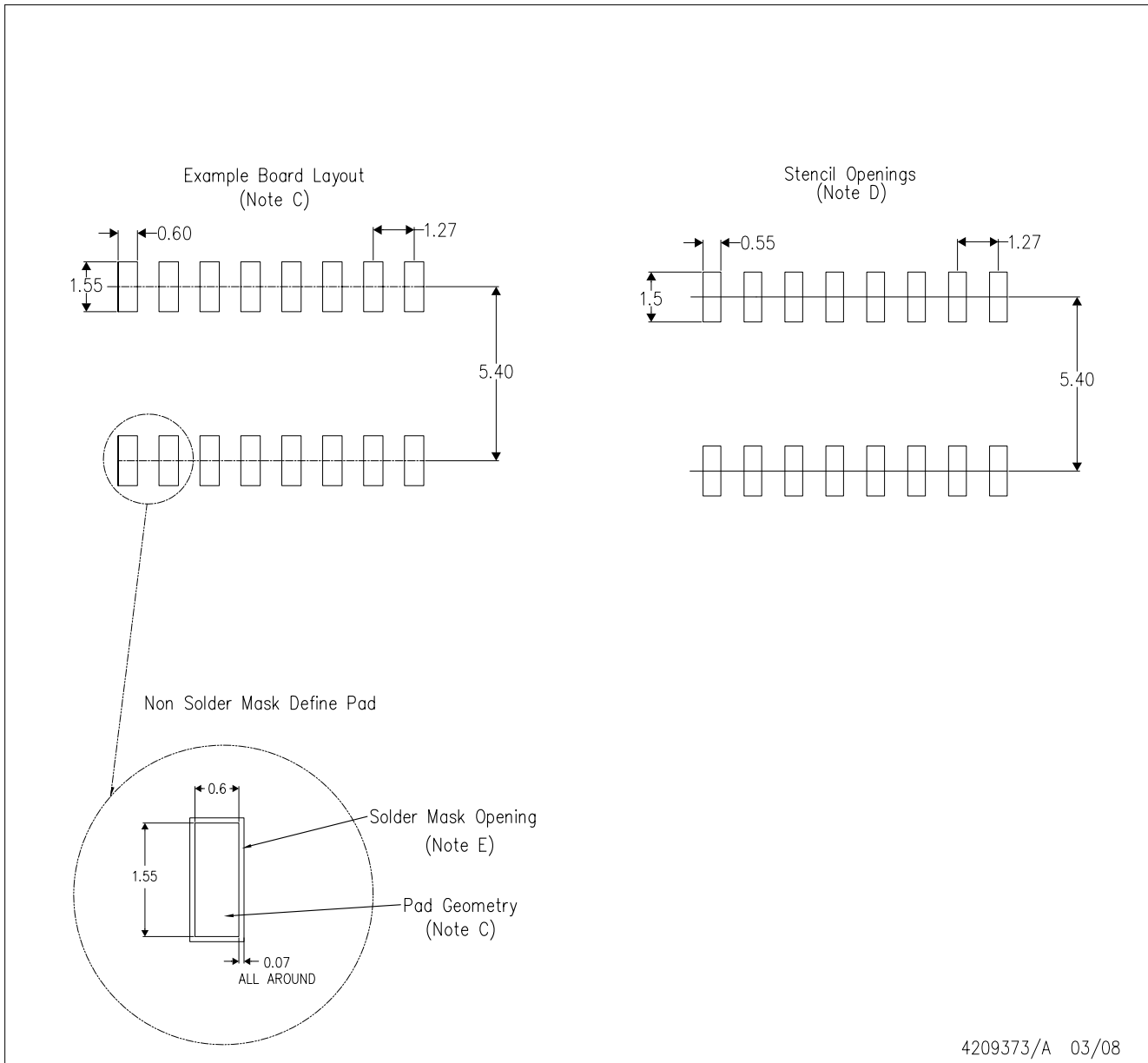

4209373/A 03/08

- NOTES:
- A. All linear dimensions are in millimeters.
  - B. This drawing is subject to change without notice.
  - C. Refer to IPC7351 for alternate board design.
  - D. Laser cutting apertures with trapezoidal walls and also rounding corners will offer better paste release. Customers should contact their board assembly site for stencil design recommendations. Refer to IPC-7525
  - E. Customers should contact their board fabrication site for solder mask tolerances between and around signal pads.

N (R-PDIP-T\*\*)

PLASTIC DUAL-IN-LINE PACKAGE

16 PINS SHOWN



- NOTES:
- A. All linear dimensions are in inches (millimeters).
  - B. This drawing is subject to change without notice.
  - Falls within JEDEC MS-001, except 18 and 20 pin minimum body length (Dim A).
  - The 20 pin end lead shoulder width is a vendor option, either half or full width.

## IMPORTANT NOTICE

Texas Instruments Incorporated and its subsidiaries (TI) reserve the right to make corrections, modifications, enhancements, improvements, and other changes to its products and services at any time and to discontinue any product or service without notice. Customers should obtain the latest relevant information before placing orders and should verify that such information is current and complete. All products are sold subject to TI's terms and conditions of sale supplied at the time of order acknowledgment.

TI warrants performance of its hardware products to the specifications applicable at the time of sale in accordance with TI's standard warranty. Testing and other quality control techniques are used to the extent TI deems necessary to support this warranty. Except where mandated by government requirements, testing of all parameters of each product is not necessarily performed.

TI assumes no liability for applications assistance or customer product design. Customers are responsible for their products and applications using TI components. To minimize the risks associated with customer products and applications, customers should provide adequate design and operating safeguards.

TI does not warrant or represent that any license, either express or implied, is granted under any TI patent right, copyright, mask work right, or other TI intellectual property right relating to any combination, machine, or process in which TI products or services are used. Information published by TI regarding third-party products or services does not constitute a license from TI to use such products or services or a warranty or endorsement thereof. Use of such information may require a license from a third party under the patents or other intellectual property of the third party, or a license from TI under the patents or other intellectual property of TI.

Reproduction of TI information in TI data books or data sheets is permissible only if reproduction is without alteration and is accompanied by all associated warranties, conditions, limitations, and notices. Reproduction of this information with alteration is an unfair and deceptive business practice. TI is not responsible or liable for such altered documentation. Information of third parties may be subject to additional restrictions.

Resale of TI products or services with statements different from or beyond the parameters stated by TI for that product or service voids all express and any implied warranties for the associated TI product or service and is an unfair and deceptive business practice. TI is not responsible or liable for any such statements.

TI products are not authorized for use in safety-critical applications (such as life support) where a failure of the TI product would reasonably be expected to cause severe personal injury or death, unless officers of the parties have executed an agreement specifically governing such use. Buyers represent that they have all necessary expertise in the safety and regulatory ramifications of their applications, and acknowledge and agree that they are solely responsible for all legal, regulatory and safety-related requirements concerning their products and any use of TI products in such safety-critical applications, notwithstanding any applications-related information or support that may be provided by TI. Further, Buyers must fully indemnify TI and its representatives against any damages arising out of the use of TI products in such safety-critical applications.

TI products are neither designed nor intended for use in military/aerospace applications or environments unless the TI products are specifically designated by TI as military-grade or "enhanced plastic." Only products designated by TI as military-grade meet military specifications. Buyers acknowledge and agree that any such use of TI products which TI has not designated as military-grade is solely at the Buyer's risk, and that they are solely responsible for compliance with all legal and regulatory requirements in connection with such use.

TI products are neither designed nor intended for use in automotive applications or environments unless the specific TI products are designated by TI as compliant with ISO/TS 16949 requirements. Buyers acknowledge and agree that, if they use any non-designated products in automotive applications, TI will not be responsible for any failure to meet such requirements.

Following are URLs where you can obtain information on other Texas Instruments products and application solutions:

### Products

Amplifiers	<a href="http://amplifier.ti.com">amplifier.ti.com</a>
Data Converters	<a href="http://dataconverter.ti.com">dataconverter.ti.com</a>
DSP	<a href="http://dsp.ti.com">dsp.ti.com</a>
Clocks and Timers	<a href="http://www.ti.com/clocks">www.ti.com/clocks</a>
Interface	<a href="http://interface.ti.com">interface.ti.com</a>
Logic	<a href="http://logic.ti.com">logic.ti.com</a>
Power Mgmt	<a href="http://power.ti.com">power.ti.com</a>
Microcontrollers	<a href="http://microcontroller.ti.com">microcontroller.ti.com</a>
RFID	<a href="http://www.ti-rfid.com">www.ti-rfid.com</a>
RF/IF and ZigBee® Solutions	<a href="http://www.ti.com/lprf">www.ti.com/lprf</a>

### Applications

Audio	<a href="http://www.ti.com/audio">www.ti.com/audio</a>
Automotive	<a href="http://www.ti.com/automotive">www.ti.com/automotive</a>
Broadband	<a href="http://www.ti.com/broadband">www.ti.com/broadband</a>
Digital Control	<a href="http://www.ti.com/digitalcontrol">www.ti.com/digitalcontrol</a>
Medical	<a href="http://www.ti.com/medical">www.ti.com/medical</a>
Military	<a href="http://www.ti.com/military">www.ti.com/military</a>
Optical Networking	<a href="http://www.ti.com/opticalnetwork">www.ti.com/opticalnetwork</a>
Security	<a href="http://www.ti.com/security">www.ti.com/security</a>
Telephony	<a href="http://www.ti.com/telephony">www.ti.com/telephony</a>
Video & Imaging	<a href="http://www.ti.com/video">www.ti.com/video</a>
Wireless	<a href="http://www.ti.com/wireless">www.ti.com/wireless</a>

Mailing Address: Texas Instruments, Post Office Box 655303, Dallas, Texas 75265  
Copyright © 2008, Texas Instruments Incorporated