

UCC53x0 4.3-A, 3-kV_{RMS} Isolated Single-Channel Gate Drivers

1 Features

- Isolated Single-Channel Gate Driver With Peak Current up to 4.3 A
- 3-V to 15-V Input Supply Voltage
- 13.2-V to 33-V Output Driver Supply Voltage
- Feature Options
 - Split Outputs (UCC5320S)
 - UVLO With Respect to IGBT Emitter (UCC5320E)
 - Miller Clamp Option (UCC5310M)
- CMOS Inputs
- Negative Voltage Handling Capability on Input Pins
- 75-ns (Maximum) Propagation Delay
- 100-kV/ μ s Minimum Common-Mode Transient Immunity (CMTI)
- 4-kV ESD on All Pins
- Operating Temperature: -55°C to $+125^{\circ}\text{C}$ Ambient
- Isolation Surge Withstand Voltage: 4242 V_{PK}
- 8-pin Narrow Body SOIC Package
- Safety-Related Certifications:
 - 4242-V_{PK} Isolation per DIN V VDE V 0884-10 and DIN EN 61010-1 (Planned)
 - 3000-V_{RMS} Isolation for 1 Minute per UL 1577 (Planned)
 - CSA Component Acceptance Notice 5A, IEC 60950-1 and IEC 61010-1 End Equipment Standards (Planned)
 - CQC Certification per GB4943.1-2011 (Planned)

2 Applications

- Industrial Motor-Control Drives
- Industrial Power Supplies
- Solar Inverters
- HEV and EV Power Modules
- Induction Heating

3 Description

The UCC53x0 is a family of compact, single-channel, isolated IGBT, SiC, and MOSFET gate drivers with superior isolation ratings and variants for pinout configuration and drive strength.

The UCC53x0 is available in an 8-pin SOIC (D) package. This package has a creepage and clearance of 4 mm and can support isolation voltage up to 3 kV_{RMS}, which is good for applications where basic isolation is needed. With these various options and wide power range, the UCC53x0 family is a good fit for motor drives and industrial power supplies.

The UCC53x0S option provides a split output that can be used to control the rise and fall times of the driver. The UCC53x0M option connects the gate of the transistor to an internal clamp to prevent false turnon caused by Miller current. The UCC53x0E option has its UVLO2 referenced to GND2, which facilitates bipolar supplies.

Unlike an optocoupler, the UCC53x0 family has lower part-to-part skew, lower propagation delay, higher operating temperature, and higher CMTI.

Device Information⁽¹⁾

PART NUMBER	PACKAGE	BODY SIZE (NOM)
UCC5310	D (8)	4.90 mm × 3.91 mm
UCC5320		

(1) For all available packages, see the orderable addendum at the end of the data sheet.

Functional Block Diagram (S Version)

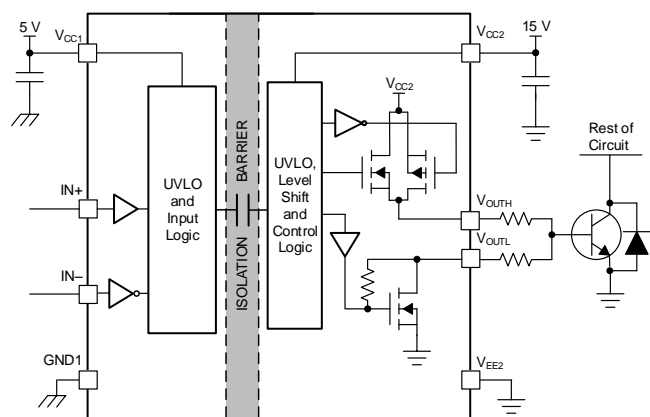

Copyright © 2017, Texas Instruments Incorporated



Table of Contents

1 Features	1	8.1 Overview	16
2 Applications	1	8.2 Functional Block Diagram	16
3 Description	1	8.3 Feature Description	18
4 Revision History	2	8.4 Device Functional Modes	22
5 Pin Configuration and Function	3	9 Application and Implementation	25
6 Specifications	4	9.1 Application Information	25
6.1 Absolute Maximum Ratings	4	9.2 Typical Application	25
6.2 ESD Ratings	4	10 Power Supply Recommendations	31
6.3 Recommended Operating Conditions	4	11 Layout	32
6.4 Thermal Information	5	11.1 Layout Guidelines	32
6.5 Power Ratings	5	11.2 Layout Example	33
6.6 Insulation Specifications	6	11.3 PCB Material	35
6.7 Safety-Related Certifications	7	12 Device and Documentation Support	36
6.8 Safety Limiting Values	7	12.1 Documentation Support	36
6.9 Electrical Characteristics	8	12.2 Related Links	36
6.10 Switching Characteristics	9	12.3 Receiving Notification of Documentation Updates	36
6.11 Insulation Characteristics Curves	10	12.4 Community Resources	36
6.12 Typical Characteristics	11	12.5 Trademarks	36
7 Parameter Measurement Information	13	12.6 Electrostatic Discharge Caution	36
7.1 Propagation Delay, Inverting, and Noninverting Configuration	13	12.7 Glossary	36
8 Detailed Description	16	13 Mechanical, Packaging, and Orderable Information	37

4 Revision History

NOTE: Page numbers for previous revisions may differ from page numbers in the current version.

Changes from Original (June 2017) to Revision A

Page

- | | |
|---|---|
| • Deleted 17 A from title which is available for future 10-A device | 1 |
|---|---|

5 Pin Configuration and Function

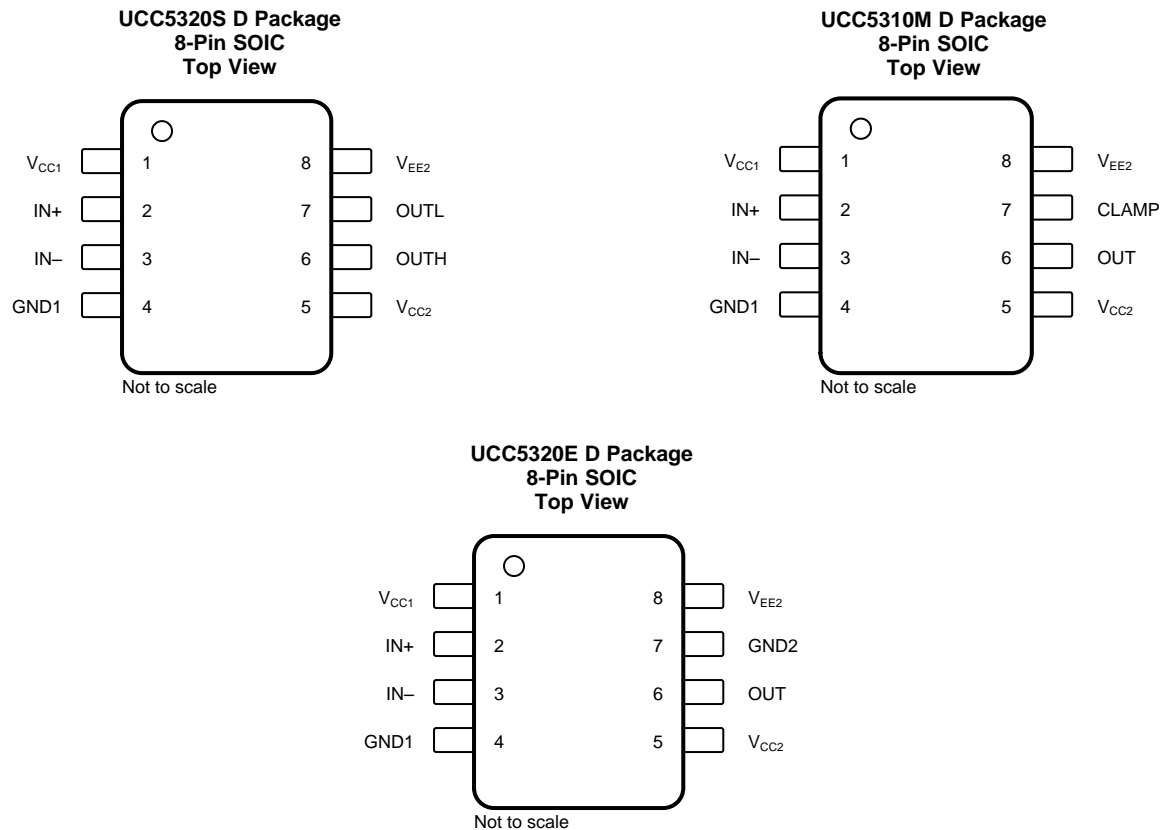

Pin Functions

NAME	PIN NO.			TYPE ⁽¹⁾	DESCRIPTION
	UCC53x0S	UCC53x0M	UCC53x0E		
CLAMP	—	7	—	I	Active Miller-clamp input found on the UCC5310M used to prevent false turnon of the power switches.
GND1	4	4	4	G	Input ground. All signals on the input side are referenced to this ground.
GND2	—	—	7	G	Gate-drive common pin. Connect this pin to the IGBT emitter. UVLO referenced to GND2 in the UCC5320E variations.
IN+	2	2	2	I	Noninverting gate-drive voltage-control input. The IN+ pin has a CMOS input threshold. This pin is pulled low internally if left open. Use Table 5 to understand the input and output logic of these devices.
IN-	3	3	3	I	Inverting gate-drive voltage control input. The IN- pin has a CMOS input threshold. This pin is pulled high internally if left open. Use Table 5 to understand the input and output logic of these devices.
OUT	—	6	6	O	Gate-drive output for E and M versions.
OUTH	6	—	—	O	Gate-drive pullup output found on the UCC5320S.
OUTL	7	—	—	O	Gate-drive pulldown output found on the UCC5320S.
V _{CC1}	1	1	1	P	Input supply voltage. Connect a locally decoupled capacitor to GND. Use a low-ESR or ESL capacitor located as close to the device as possible.
V _{CC2}	5	5	5	P	Positive output supply rail. Connect a locally decoupled capacitor to V _{EE2} . Use a low-ESR or ESL capacitor located as close to the device as possible.
V _{EE2}	8	8	8	P	Negative output supply rail for E version, and GND for S and M versions. Connect a locally decoupled capacitor to GND2 for E version. Use a low-ESR or ESL capacitor located as close to the device as possible.

(1) P = Power, G = Ground, I = Input, O = Output

6 Specifications

6.1 Absolute Maximum Ratings

Over operating free air temperature range (unless otherwise noted)⁽¹⁾

		MIN	MAX	UNIT
Input bias pin supply voltage	$V_{CC1} - GND1$	$GND1 - 0.3$	18	V
Driver bias supply	$V_{CC2} - V_{EE2}$	-0.3	35	V
V_{EE2} bipolar supply voltage for E version	$V_{EE2} - GND2$	-17.5	0.3	V
Output signal voltage	$V_{OUTH} - V_{EE2}, V_{OUTL} - V_{EE2}, V_{OUT} - V_{EE2}, V_{CLAMP} - V_{EE2}$	$V_{EE2} - 0.3$	$V_{CC2} + 0.3$	V
Input signal voltage	$V_{IN+} - GND1, V_{IN-} - GND1$	$GND1 - 5$	$V_{CC1} + 0.3$	V
Junction temperature, T_J ⁽²⁾		-55	150	°C
Storage temperature, T_{stg}			150	°C

- (1) Stresses beyond those listed under *Absolute Maximum Ratings* may cause permanent damage to the device. These are stress ratings only, which do not imply functional operation of the device at these or any other conditions beyond those indicated under *Recommended Operating Conditions*. Exposure to absolute-maximum-rated conditions for extended periods may affect device reliability.
- (2) To maintain the recommended operating conditions for T_J , see the [Thermal Information](#).

6.2 ESD Ratings

		VALUE	UNIT
$V_{(ESD)}$	Electrostatic discharge		
	Human body model (HBM), per ANSI/ESDA/JEDEC JS-001 ⁽¹⁾	±4000	V
Charged device model (CDM), per JEDEC specification JESD22-C101 ⁽²⁾	±1500		

- (1) JEDEC document JEP155 states that 500-V HBM allows safe manufacturing with a standard ESD control process.
- (2) JEDEC document JEP157 states that 250-V CDM allows safe manufacturing with a standard ESD control process.

6.3 Recommended Operating Conditions

Over operating free-air temperature range (unless otherwise noted)

		MIN	NOM	MAX	UNIT
V_{CC1}	Supply voltage, input side	3		15	V
V_{CC2}	Positive supply voltage output side ($V_{CC2} - V_{EE2}$)	13.2		33	V
V_{EE2}	Bipolar supply voltage for E version ($V_{EE2} - GND2$)	-16		0	V
V_{SUP2}	Total supply voltage output side ($V_{CC2} - V_{EE2}$)	13.2		33	V
T_A	Ambient temperature	-55		125	°C

6.4 Thermal Information

THERMAL METRIC ⁽¹⁾		UCC53x0	
		D (SOIC)	
		8 PINS	
			UNIT
$R_{\theta JA}$	Junction-to-ambient thermal resistance	109.5	°C/W
$R_{\theta JC(top)}$	Junction-to-case (top) thermal resistance	43.1	°C/W
$R_{\theta JB}$	Junction-to-board thermal resistance	51.2	°C/W
Ψ_{JT}	Junction-to-top characterization parameter	18.3	°C/W
Ψ_{JB}	Junction-to-board characterization parameter	50.7	°C/W

(1) For more information about traditional and new thermal metrics, see the [Semiconductor and IC Package Thermal Metrics](#) application report.

6.5 Power Ratings

PARAMETER		TEST CONDITIONS	MIN	TYP	MAX	UNIT
P_D	Maximum power dissipation on input and output	$V_{CC1} = 5\text{ V}$, $V_{CC2} = 15\text{ V}$, $IN+ = 3.3\text{ V}$, $IN- = GND1$, 687-kHz, 50% duty cycle, square wave, 2.4-nF load			1.14	W
P_{D1}	Maximum input power dissipation	$V_{CC1} = 5\text{ V}$, $V_{CC2} = 15\text{ V}$, $IN+ = 3.3\text{ V}$, $IN- = GND1$, 687-kHz, 50% duty cycle, square wave, 2.4-nF load			0.05	W
P_{D2}	Maximum output power dissipation	$V_{CC1} = 5\text{ V}$, $V_{CC2} = 15\text{ V}$, $IN+ = 3.3\text{ V}$, $IN- = GND1$, 687-kHz, 50% duty cycle, square wave, 2.4-nF load			1.09	W

6.6 Insulation Specifications

PARAMETER		TEST CONDITIONS	VALUE	UNIT
CLR	External Clearance ⁽¹⁾	Shortest pin-to-pin distance through air	4	mm
CPG	External Creepage ⁽¹⁾	Shortest pin-to-pin distance across the package surface	4	mm
DTI	Distance through the insulation	Minimum internal gap (internal clearance)	> 21	μm
CTI	Comparative tracking index	DIN EN 60112 (VDE 0303–11); IEC 60112	> 600	V
	Material Group	According to IEC 60664–1	I	
	Overvoltage category per IEC 60664-1	Rated mains voltage ≤ 150 V _{RMS}	I-IV	
		Rated mains voltage ≤ 300 V _{RMS}	I-III	
DIN V VDE 0884–10 (VDE V 0884–10): 2016–2012⁽²⁾				
V _{IORM}	Maximum repetitive peak isolation voltage	AC voltage (bipolar)	990	V _{PK}
V _{IOWM}	Maximum isolation working voltage	AC voltage (sine wave); time dependent dielectric breakdown (TDDb) test	700	V _{RMS}
			990	V _{DC}
V _{IOTM}	Maximum transient isolation voltage	V _{TEST} = V _{IOTM} t = 60 s (qualification) t = 1 s (100% production)	4242	V _{PK}
V _{IOSM}	Maximum surge isolation voltage ⁽³⁾	Test method per IEC 60065, 1.2/50 μs waveform, V _{TEST} = 1.3 × V _{IOSM} (qualification)	4242	V _{PK}
q _{pd}	Apparent charge ⁽⁴⁾	Method a: After I/O safety test subgroup 2/3, V _{ini} = V _{IOTM} , t _{ini} = 60 s V _{pd(m)} = 1.2 × V _{IORM} , t _m = 10 s	≤ 5	pC
		Method a: After environmental tests subgroup 1, V _{ini} = V _{IOTM} , t _{ini} = 60 s; V _{pd(m)} = 1.3 × V _{IORM} , t _m = 10 s	≤ 5	
		Method b1: At routine test (100% production) and preconditioning (type test) V _{ini} = V _{IOTM} , t _{ini} = 1 s; V _{pd(m)} = 1.5 × V _{IORM} , t _m = 1 s	≤ 5	
C _{IO}	Barrier capacitance, input to output ⁽⁵⁾	V _{IO} = 0.4 × sin(2πft), f = 1 MHz	1.2	pF
R _{IO}	Isolation resistance, input to output ⁽⁵⁾	V _{IO} = 500 V, T _A = 25°C	> 10 ¹²	Ω
		V _{IO} = 500 V, 100°C ≤ T _A ≤ 125°C	> 10 ¹¹	
		V _{IO} = 500 V, T _S = 150°C	> 10 ⁹	
	Pollution degree		2	
	Climatic category		55/125/21	
UL 1577				
V _{ISO}	Withstand isolation voltage	V _{TEST} = V _{ISO} = 3000 V _{RMS} , t = 60 s (qualification); V _{TEST} = 1.2 × V _{ISO} = 3600 V _{RMS} , t = 1 s (100% production)	3000	V _{RMS}

- (1) Creepage and clearance requirements should be applied according to the specific equipment isolation standards of an application. Care should be taken to maintain the creepage and clearance distance of a board design to ensure that the mounting pads of the isolator on the printed-circuit board do not reduce this distance. Creepage and clearance on a printed-circuit board become equal in certain cases. Techniques such as inserting grooves, ribs, or both on a printed circuit board are used to help increase these specifications.
- (2) This coupler is suitable for basic electrical insulation only within the maximum operating ratings. Compliance with the safety ratings shall be ensured by means of suitable protective circuits.
- (3) Testing is carried out in air or oil to determine the intrinsic surge immunity of the isolation barrier.
- (4) Apparent charge is electrical discharge caused by a partial discharge (pd).
- (5) All pins on each side of the barrier tied together creating a two-pin device.

6.7 Safety-Related Certifications

VDE	CSA	UL	CQC
Plan to certify according to DIN V VDE V 0884–10 (VDE V 0884–10):2006–12 and DIN EN 61010-1 (VDE 0411-1):2011-07	Plan to certify according to CSA Component Acceptance Notice 5A, IEC 60950–1 and IEC 61010-1	Plan to certify according to UL 1577 Component Recognition Program	Plan to certify according to GB 4943.1–2011
Basic Insulation Maximum Transient isolation Overvoltage, 4242 V _{PK} ; Maximum Repetitive Peak Voltage, 990 V _{PK} ; Maximum Surge Isolation Voltage, 4242 V _{PK}	Basic insulation and Reinforced insulation per CSA 60950-1-07+A1+A2 and IEC 60950-1 2nd Ed.+A1+A2; Basic insulation working voltage per CSA 61010-1-12 and IEC 61010-1 3rd Ed.	Single protection, 3000 V _{RMS}	Basic Insulation, Altitude ≤ 5000 m, Tropical Climate, 250V _{RMS} maximum working voltage
Certification planned	Certification planned	Certification planned	Certification planned

6.8 Safety Limiting Values

Safety limiting⁽¹⁾ intends to minimize potential damage to the isolation barrier upon failure of input or output circuitry. A failure of the I/O can allow low resistance to ground or the supply and, without current limiting, dissipate sufficient power to overheat the die and damage the isolation barrier, potentially leading to secondary system failures.

PARAMETER	TEST CONDITIONS	MIN	TYP	MAX	UNIT
I _S Safety output supply current	R _{θJA} = 109.5°C/W, V _{CC2} = 15 V, T _J = 150°C, T _A = 25°C, see Figure 1			76	mA
	R _{θJA} = 109.5°C/W, V _{CC2} = 30 V, T _J = 150°C, T _A = 25°C, see Figure 1	Output side		38	
P _S Safety output supply power	R _{θJA} = 109.5°C/W, T _J = 150°C, T _A = 25°C, see Figure 2	Input side		0.05	W
		Output side		1.09	
		Total		1.14	
T _S Maximum safety temperature				150	°C

- (1) The safety-limiting constraint is the maximum junction temperature specified in the data sheet. The power dissipation and junction-to-air thermal impedance of the device installed in the application hardware determines the junction temperature. The assumed junction-to-air thermal resistance in the [Thermal Information](#) table is that of a device installed on a high-K test board for leaded surface-mount packages. The power is the recommended maximum input voltage times the current. The junction temperature is then the ambient temperature plus the power times the junction-to-air thermal resistance.

6.9 Electrical Characteristics

$V_{CC1} = 3.3\text{ V}$ or 5 V , $0.1\text{-}\mu\text{F}$ capacitor from V_{CC1} to GND1, $V_{CC2} = 15\text{ V}$, $1\text{-}\mu\text{F}$ capacitor from V_{CC2} to V_{EE2} , $T_A = -55^\circ\text{C}$ to $+125^\circ\text{C}$, (unless otherwise noted)

PARAMETER		TEST CONDITIONS	MIN	TYP	MAX	UNIT
SUPPLY CURRENTS						
I_{VCC1}	Input supply quiescent current	IN+ and IN- left floating		1.67	2.4	mA
I_{VCC2}	Output supply quiescent current	IN+ and IN- left floating		1.1	1.8	mA
SUPPLY VOLTAGE UNDERVOLTAGE THRESHOLDS						
$V_{IT+(UVLO1)}$	VCC1 Positive-going UVLO threshold voltage			2.6	2.8	V
$V_{IT-(UVLO1)}$	VCC1 Negative-going UVLO threshold voltage		2.4	2.5		V
$V_{hys(UVLO1)}$	VCC1 UVLO threshold hysteresis			0.1		V
$V_{IT+(UVLO2)}$	VCC2 Positive-going UVLO threshold voltage			12	13	V
$V_{IT-(UVLO2)}$	VCC2 Negative-going UVLO threshold voltage		10.3	11		V
$V_{hys(UVLO2)}$	VCC2 UVLO threshold voltage hysteresis			1		V
LOGIC I/O						
$V_{IT+(IN)}$	Positive-going input threshold voltage (IN+, IN-)			$0.55 \times V_{CC1}$	$0.7 \times V_{CC1}$	V
$V_{IT-(IN)}$	Negative-going input threshold voltage (IN+, IN-)		$0.3 \times V_{CC1}$	$0.45 \times V_{CC1}$		V
$V_{hys(IN)}$	Input hysteresis voltage (IN+, IN-)			$0.1 \times V_{CC1}$		V
I_{IH}	High-level input leakage at IN+	IN+ = V_{CC1}		40	240	μA
I_{IL}	Low-level input leakage at IN-	IN- = GND1		-240	-40	μA
		IN- = GND1 - 5 V		-310	-80	
GATE DRIVER STAGE						
V_{OH}	High-level output voltage (OUT and OUTH)	$I_{OUT} = -20\text{ mA}$	$V_{CC2} - 0.1$	$V_{CC2} - 0.24$		V
V_{OL}	Low level output voltage (OUT and OUTL)	UCC5320S and UCC5320E, IN+ = low, IN- = high; $I_O = 20\text{ mA}$	9.4	13		mV
		UCC5310M, IN+ = low, IN- = high; $I_O = 20\text{ mA}$	17	26		
I_{OH}	Peak source current	UCC5320S and UCC5320E, IN+ = high, IN- = low	2.4	4.3		A
		UCC5310M, IN+ = high, IN- = low	2.4	4.3		
I_{OL}	Peak sink current	UCC5320S and UCC5320E, IN+ = low, IN- = high	2.2	4.4		A
		UCC5310M, IN+ = low, IN- = high	1.1	2.2		
ACTIVE MILLER CLAMP (UCC53xxM only)						
V_{CLAMP}	Low-level clamp voltage	UCC5310M, $I_{CLAMP} = 20\text{ mA}$		26	50	mV
I_{CLAMP}	Clamp low-level current	UCC5310M, $V_{CLAMP} = V_{EE2} + 15\text{ V}$	1.1	2.2		A
$I_{CLAMP(L)}$	Clamp low-level current for low output voltage	UCC5310M, $V_{CLAMP} = V_{EE2} + 2\text{ V}$	0.7	1.5		A
$V_{CLAMP-TH}$	Clamp threshold voltage			2.1	2.3	V
SHORT CIRCUIT CLAMPING						
$V_{CLP-OUT}$	Clamping voltage ($V_{OUTH} - V_{CC2}$ or $V_{OUT} - V_{CC2}$)	IN+ = high, IN- = low, $t_{CLAMP} = 10\text{ }\mu\text{s}$, I_{OUTH} or $I_{OUT} = 500\text{ mA}$		1	1.3	V

Electrical Characteristics (continued)

$V_{CC1} = 3.3\text{ V}$ or 5 V , $0.1\text{-}\mu\text{F}$ capacitor from V_{CC1} to GND1, $V_{CC2} = 15\text{ V}$, $1\text{-}\mu\text{F}$ capacitor from V_{CC2} to V_{EE2} , $T_A = -55^\circ\text{C}$ to $+125^\circ\text{C}$, (unless otherwise noted)

PARAMETER	TEST CONDITIONS	MIN	TYP	MAX	UNIT
$V_{CLP-OUT}$	Clamping voltage ($V_{EE2} - V_{OUTL}$ or $V_{EE2} - V_{CLAMP}$ or $V_{EE2} - V_{OUT}$)	IN+ = low, IN- = high, $t_{CLAMP} = 10\ \mu\text{s}$, I_{CLAMP} or $I_{OUTL} = -500\ \text{mA}$	1.5		V
		IN+ = low, IN- = high, I_{CLAMP} or $I_{OUTL} = -20\ \text{mA}$	0.9	1	
ACTIVE PULLDOWN					
V_{OUTSD}	Active pulldown voltage on OUTL, CLAMP, OUT	I_{OUTL} or $I_{OUT} = 0.1 \times I_{OUTL(typ)}$, $V_{CC2} =$ open	1.8	2.5	V

6.10 Switching Characteristics

$V_{CC1} = 3.3\text{ V}$ or 5 V , $0.1\text{-}\mu\text{F}$ capacitor from V_{CC1} to GND1, $V_{CC2} = 15\text{ V}$, $1\text{-}\mu\text{F}$ capacitor from V_{CC2} to V_{EE2} , $T_A = -55^\circ\text{C}$ to $+125^\circ\text{C}$, (unless otherwise noted)

PARAMETER	TEST CONDITIONS	MIN	TYP	MAX	UNIT
t_r	Output-signal rise time		12	28	ns
t_f	Output-signal fall time	UCC5320S and UCC5320E, $C_{LOAD} = 1\ \text{nF}$	10	25	ns
		UCC5310M, $C_{LOAD} = 1\ \text{nF}$	10	26	ns
t_{PLH}	Propagation delay (default versions), high	UCC5320S and UCC5320E, $C_{LOAD} = 100\ \text{pF}$	60	72	ns
		UCC5310M, $C_{LOAD} = 100\ \text{pF}$	60	75	ns
t_{PHL}	Propagation delay (default versions), low	UCC5320S and UCC5320E, $C_{LOAD} = 100\ \text{pF}$	60	75	ns
		UCC5310M, $C_{LOAD} = 100\ \text{pF}$	60	75	ns
t_{UVLO1_rec}	UVLO recovery delay of V_{CC1}		30		μs
t_{UVLO2_rec}	UVLO recovery delay of V_{CC2}		50		μs
t_{PWD}	Pulse width distortion $ t_{PHL} - t_{PLH} $	UCC5320S and UCC5320E, $C_{LOAD} = 100\ \text{pF}$	1	20	ns
		UCC5310M, $C_{LOAD} = 100\ \text{pF}$	1	20	ns
$t_{sk(pp)}$	Part-to-part skew ⁽¹⁾	UCC5320S and UCC5320E, $C_{LOAD} = 100\ \text{pF}$	1	25	ns
		UCC5310M, $C_{LOAD} = 100\ \text{pF}$	1	25	ns
CMTI	Common-mode transient immunity	PWM is tied to GND or V_{CC1} , $V_{CM} = 1200\ \text{V}$	100	120	kV/ μs

- (1) $t_{sk(pp)}$ is the magnitude of the difference in propagation delay times between the output of different devices switching in the same direction while operating at identical supply voltages, temperature, input signals and loads guaranteed by characterization.

6.11 Insulation Characteristics Curves

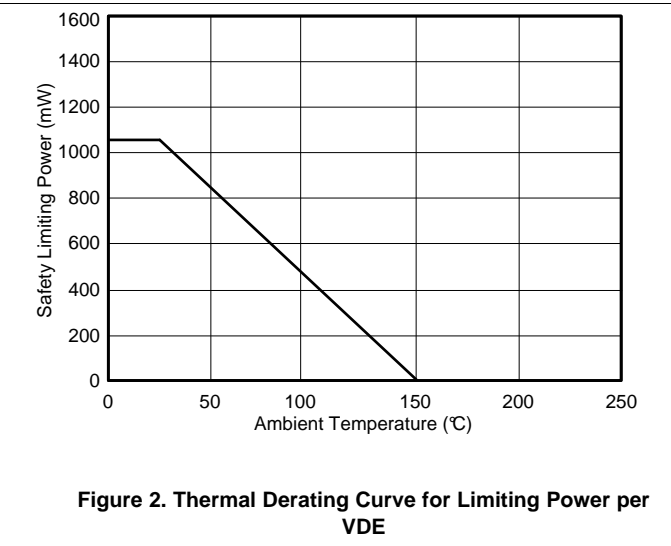
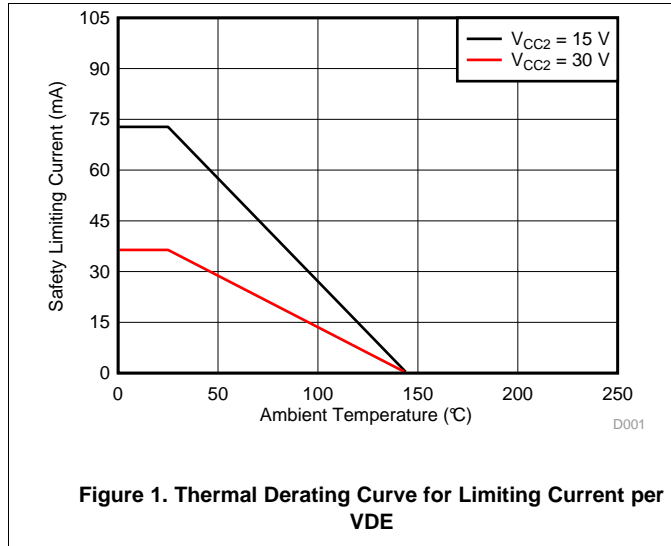

6.12 Typical Characteristics

$V_{CC1} = 3.3\text{ V}$ or 5 V , $0.1\text{-}\mu\text{F}$ capacitor from V_{CC1} to GND1 , $V_{CC2} = 15\text{ V}$, $1\text{-}\mu\text{F}$ capacitor from V_{CC2} to V_{EE2} , $C_{LOAD} = 1\text{ nF}$, $T_A = -55^\circ\text{C}$ to $+125^\circ\text{C}$, (unless otherwise noted)

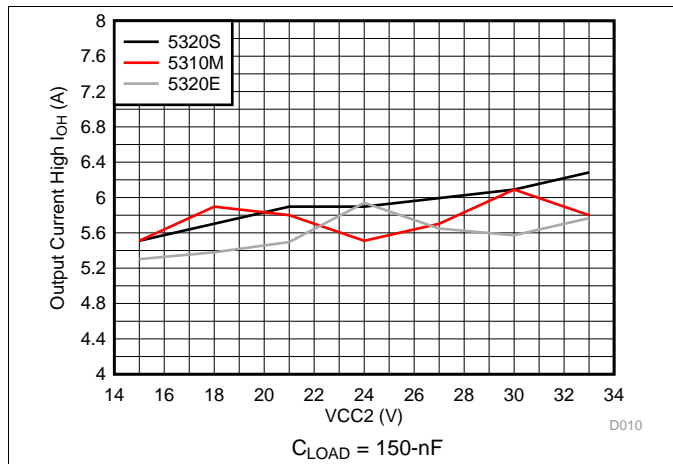

Figure 3. Output-High Drive Current vs Output Voltage

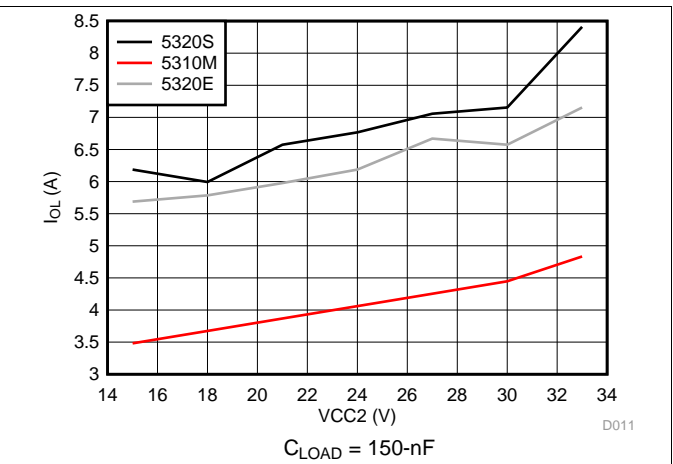

Figure 4. Output-Low Drive Current vs Output Voltage

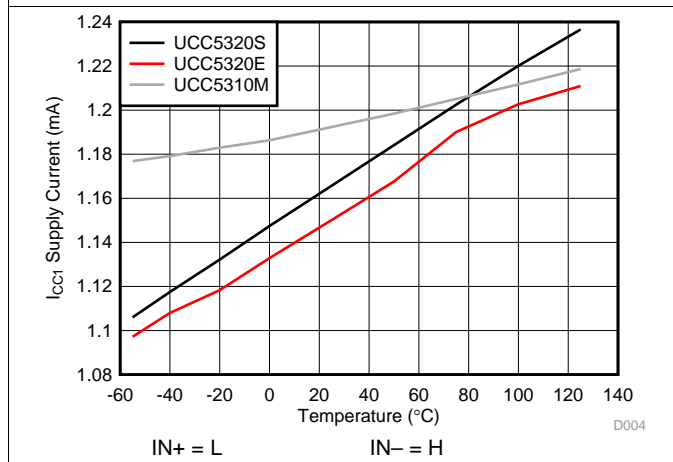

Figure 5. I_{CC1} Supply Current vs Temperature

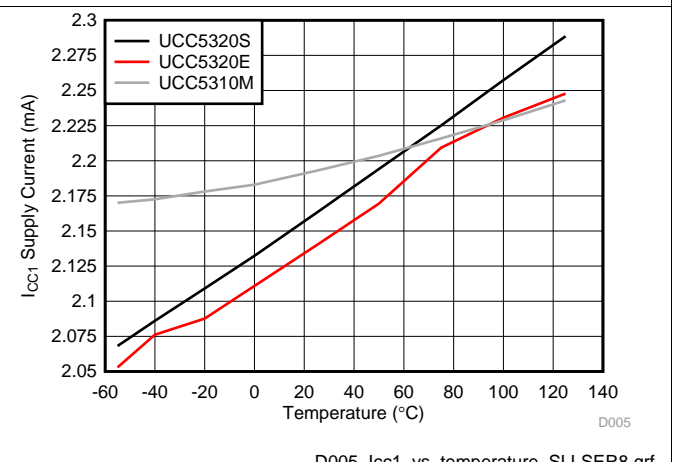

Figure 6. I_{CC1} Supply Current vs Temperature

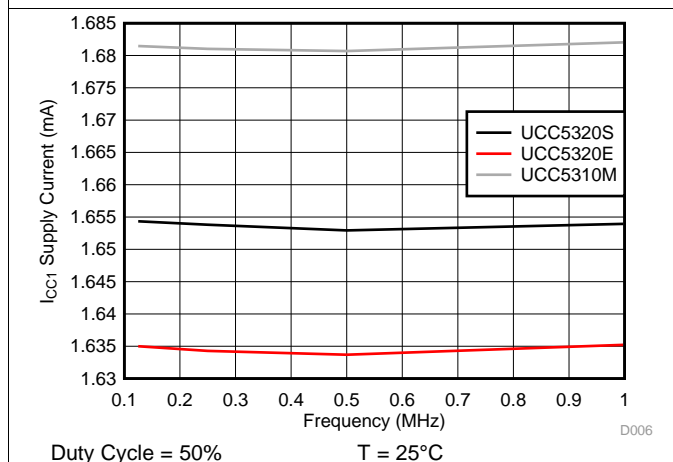

Figure 7. I_{CC1} Supply Current vs Input Frequency

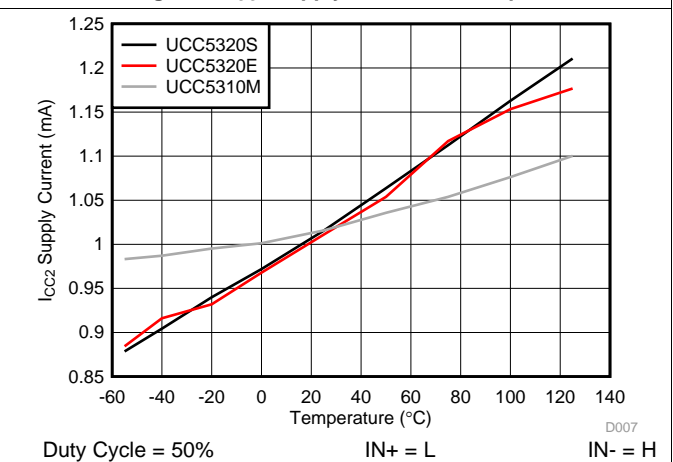

Figure 8. I_{CC2} Supply Current vs Temperature

Typical Characteristics (continued)

$V_{CC1} = 3.3\text{ V}$ or 5 V , $0.1\text{-}\mu\text{F}$ capacitor from V_{CC1} to $GND1$, $V_{CC2} = 15\text{ V}$, $1\text{-}\mu\text{F}$ capacitor from V_{CC2} to V_{EE2} , $C_{LOAD} = 1\text{ nF}$, $T_A = -55^\circ\text{C}$ to $+125^\circ\text{C}$, (unless otherwise noted)

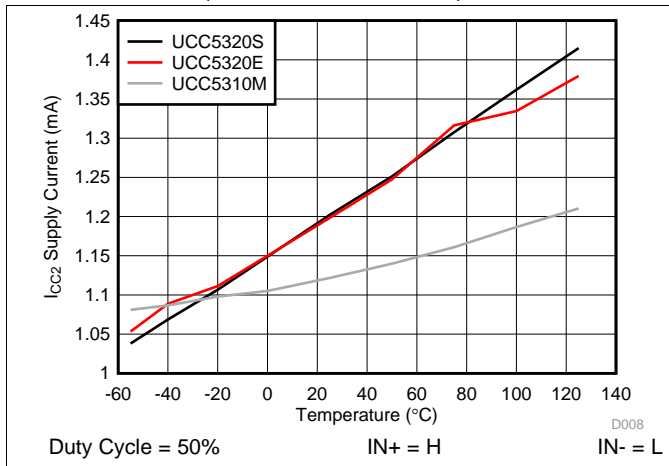

Figure 9. I_{CC1} Supply Current vs Input Frequency

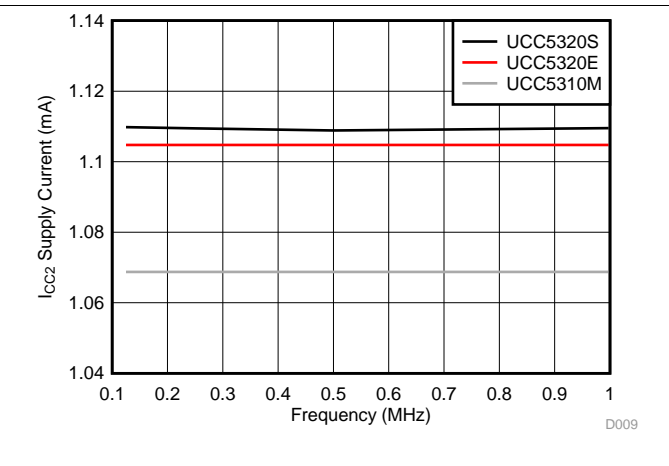

Figure 10. I_{CC2} Supply Current vs Input Frequency

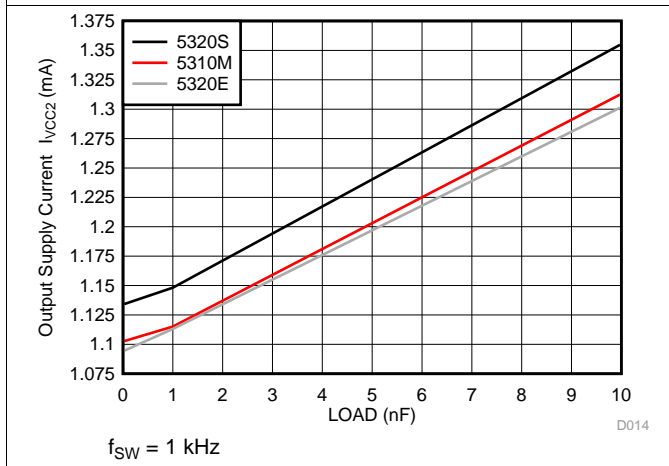

Figure 11. I_{CC2} Supply Current vs Load Capacitance

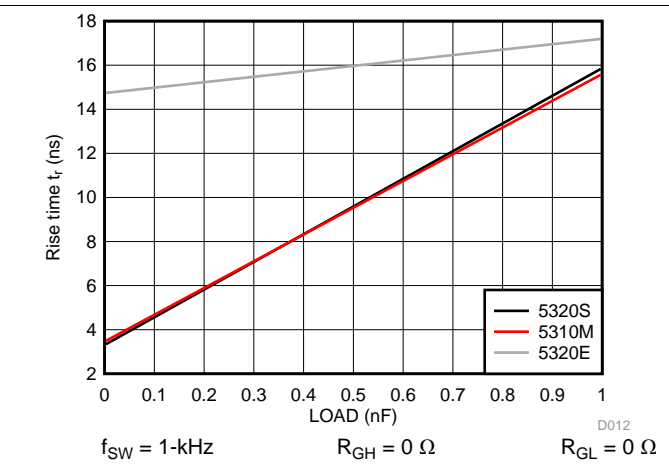

Figure 12. Rise Time vs Load Capacitance

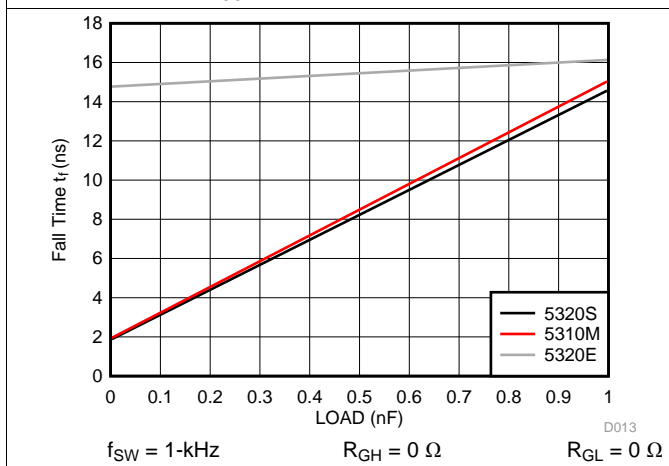

Figure 13. Fall Time vs Load Capacitance

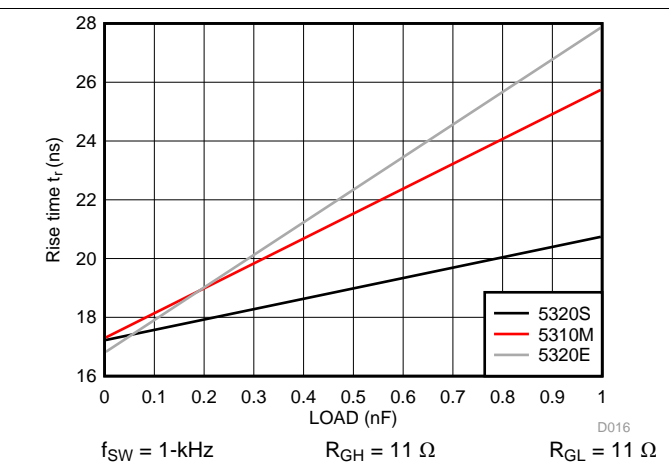
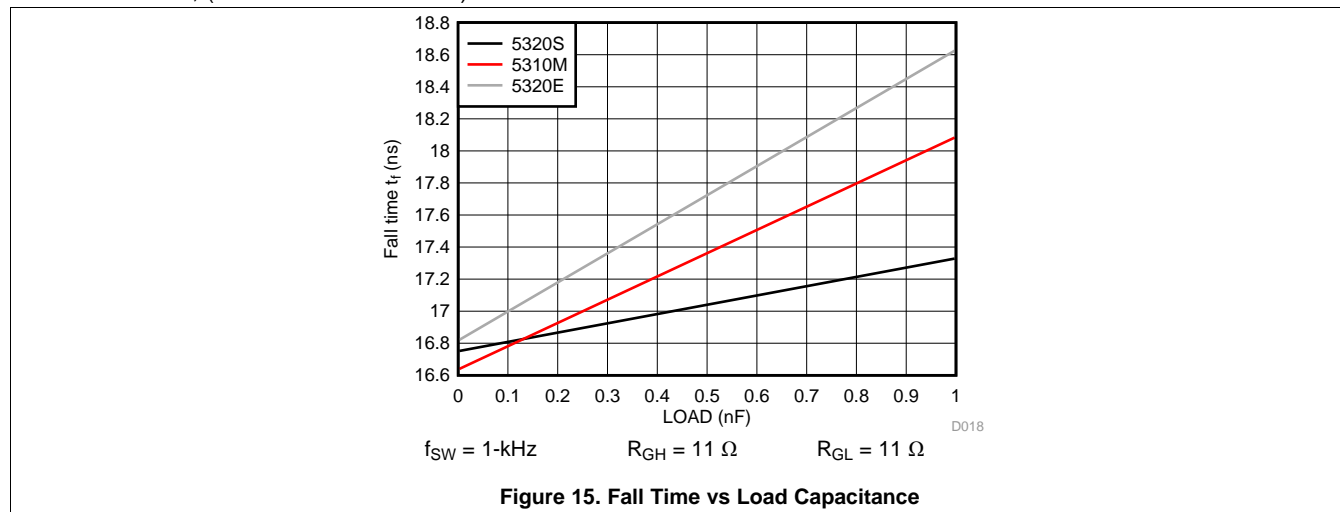

Figure 14. Rise Time vs Load Capacitance

Typical Characteristics (continued)

$V_{CC1} = 3.3\text{ V}$ or 5 V , $0.1\text{-}\mu\text{F}$ capacitor from V_{CC1} to GND1 , $V_{CC2} = 15\text{ V}$, $1\text{-}\mu\text{F}$ capacitor from V_{CC2} to V_{EE2} , $C_{LOAD} = 1\text{ nF}$, $T_A = -55^\circ\text{C}$ to $+125^\circ\text{C}$, (unless otherwise noted)



7 Parameter Measurement Information

7.1 Propagation Delay, Inverting, and Noninverting Configuration

Figure 16 shows the propagation delay OUTH and OUTL for noninverting configurations. Figure 17 shows the propagation delay with the inverting configuration. These figures also demonstrate the method used to measure the rise (t_r) and fall (t_f) times.

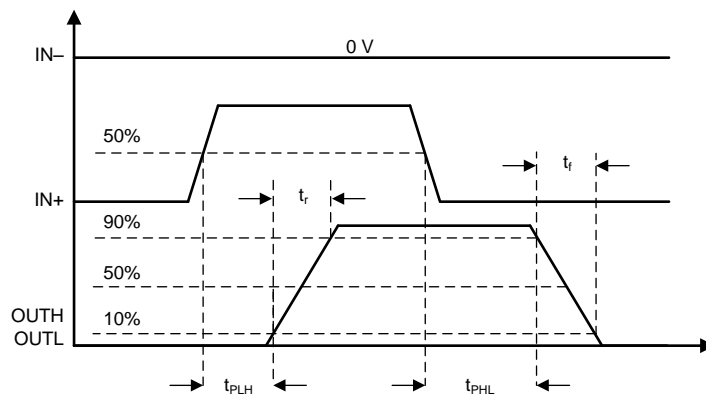

Figure 16. OUTH and OUTL Propagation Delay, Noninverting Configuration

Propagation Delay, Inverting, and Noninverting Configuration (continued)

Figure 17. OUTH and OUTL Propagation Delay, Inverting Configuration
7.1.1 CMTI Testing

Figure 18, Figure 19, and Figure 20 are simplified diagrams of the CMTI testing configuration used for each device type.

Figure 18. CMTI Test Circuit for UCC5320S

Propagation Delay, Inverting, and Noninverting Configuration (continued)

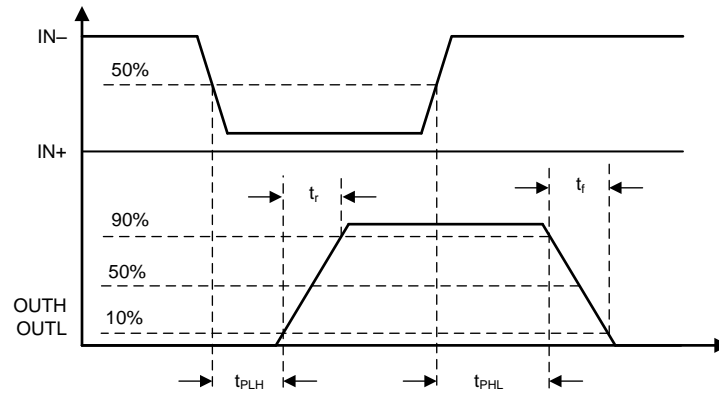
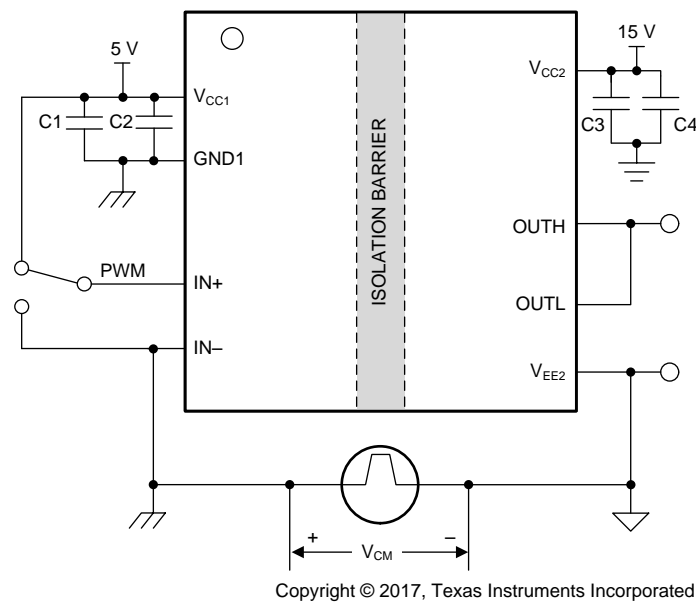
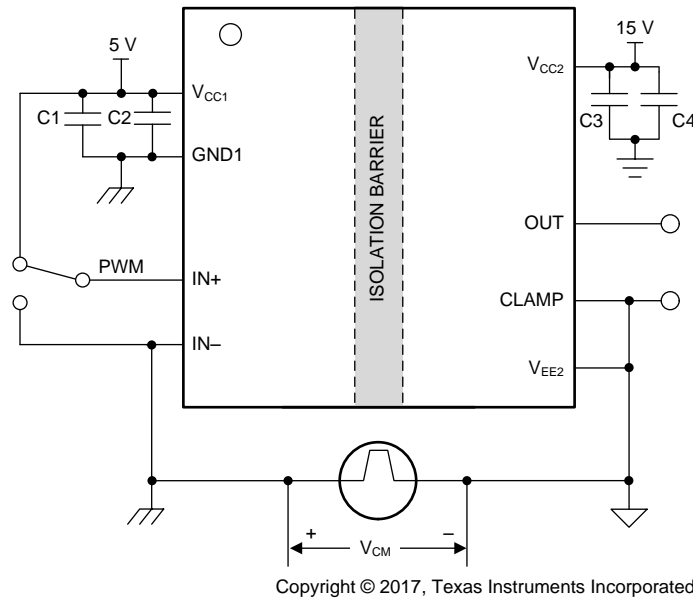

Figure 19. CMTI Test Circuit for UCC5310M

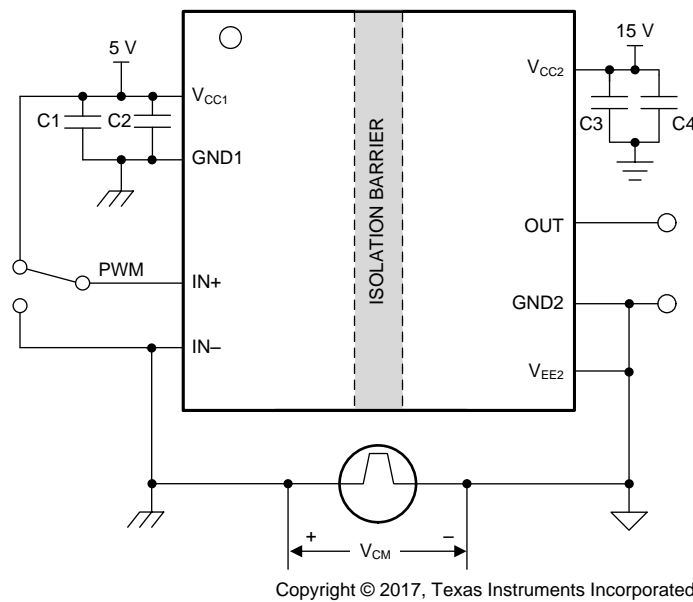

Figure 20. CMTI Test Circuit for UCC5320E

8 Detailed Description

8.1 Overview

The UCC53x0 family of isolated gate drivers with variations for built-in split output, Miller clamp, and UVLO2 referenced to GND2(see [Table 1](#)). The isolation inside the UCC53x0 family of devices is implemented with high-voltage SiO₂-based capacitors. The signal across the isolation has an on-off keying (OOK) modulation scheme to transmit the digital data across a silicon dioxide based isolation barrier (see [Figure 22](#)). The transmitter sends a high-frequency carrier across the barrier to represent one digital state and sends no signal to represent the other digital state. The receiver demodulates the signal after advanced signal conditioning and produces the output through a buffer stage. The UCC53x0 devices also incorporate advanced circuit techniques to maximize the CMTI performance and minimize the radiated emissions from the high frequency carrier and IO buffer switching. The conceptual block diagram of a digital capacitive isolator, [Figure 21](#), shows a functional block diagram of a typical channel. [Figure 22](#) shows a conceptual detail of how the OOK scheme works.

[Figure 21](#) shows how the input signal passes through the capacitive isolation barrier through modulation (OOK) and signal conditioning. [Figure 22](#) shows the OOK-based modulation scheme.

8.2 Functional Block Diagram

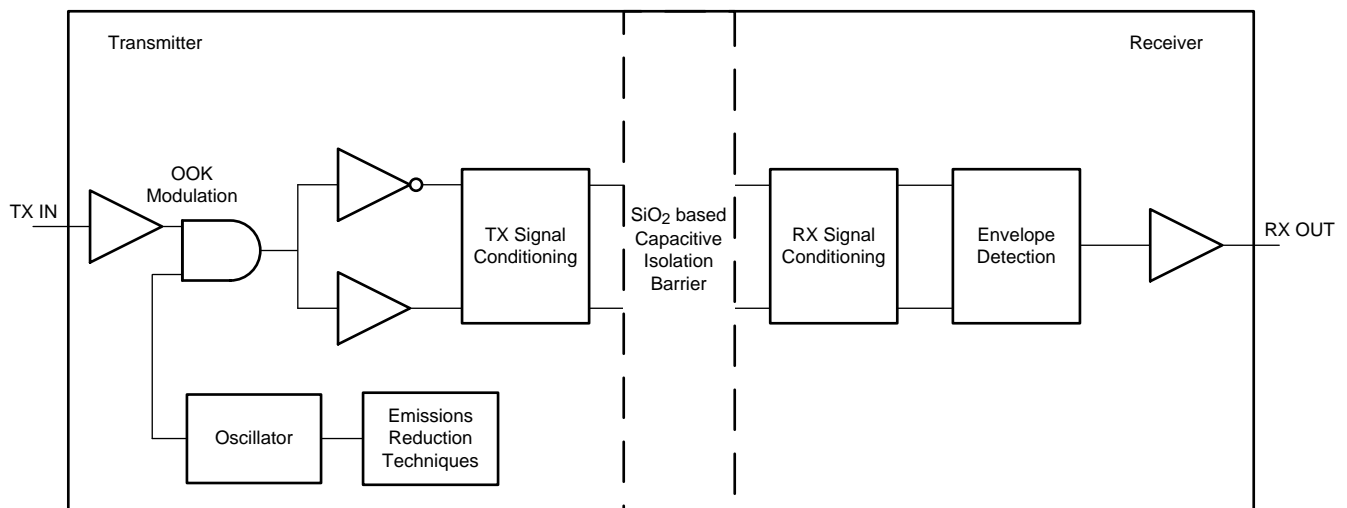

Copyright © 2017, Texas Instruments Incorporated

Figure 21. Conceptual Block Diagram of a Capacitive Data Channel

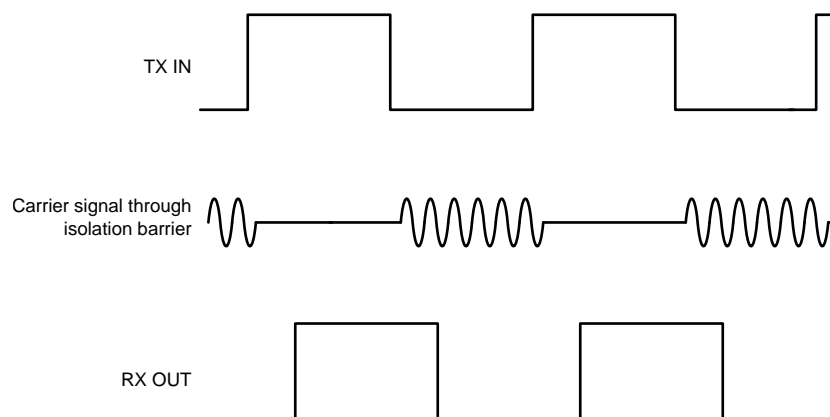

Figure 22. On-Off Keying (OOK) Based Modulation Scheme

Functional Block Diagram (continued)

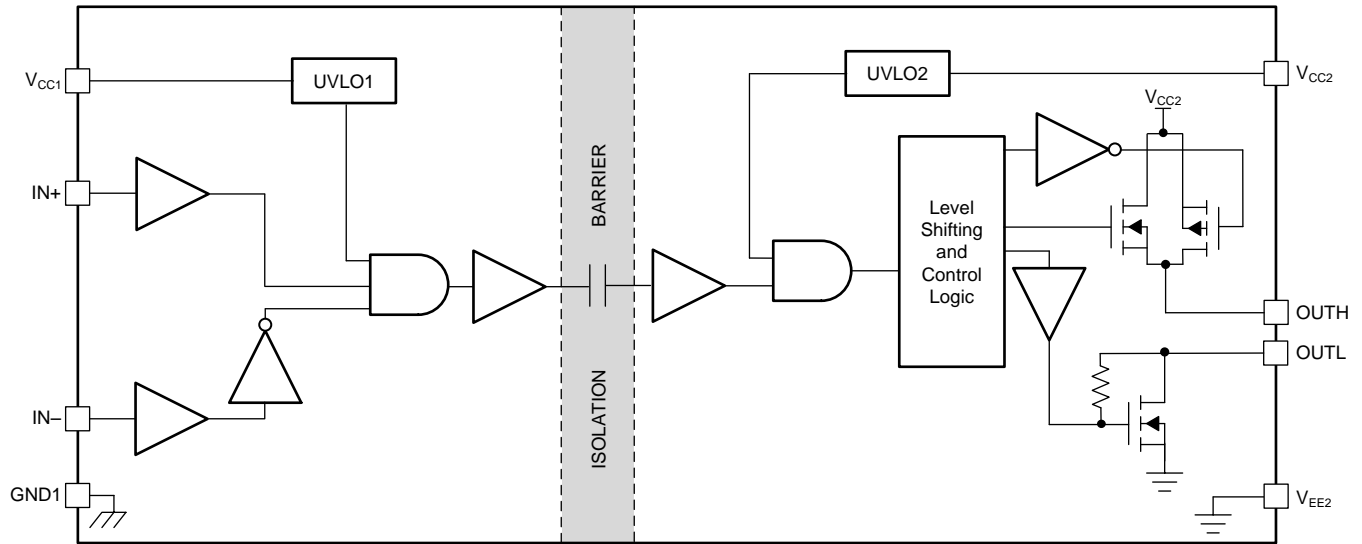

Figure 23. Functional Block Diagram—UCC5320S Split Outputs

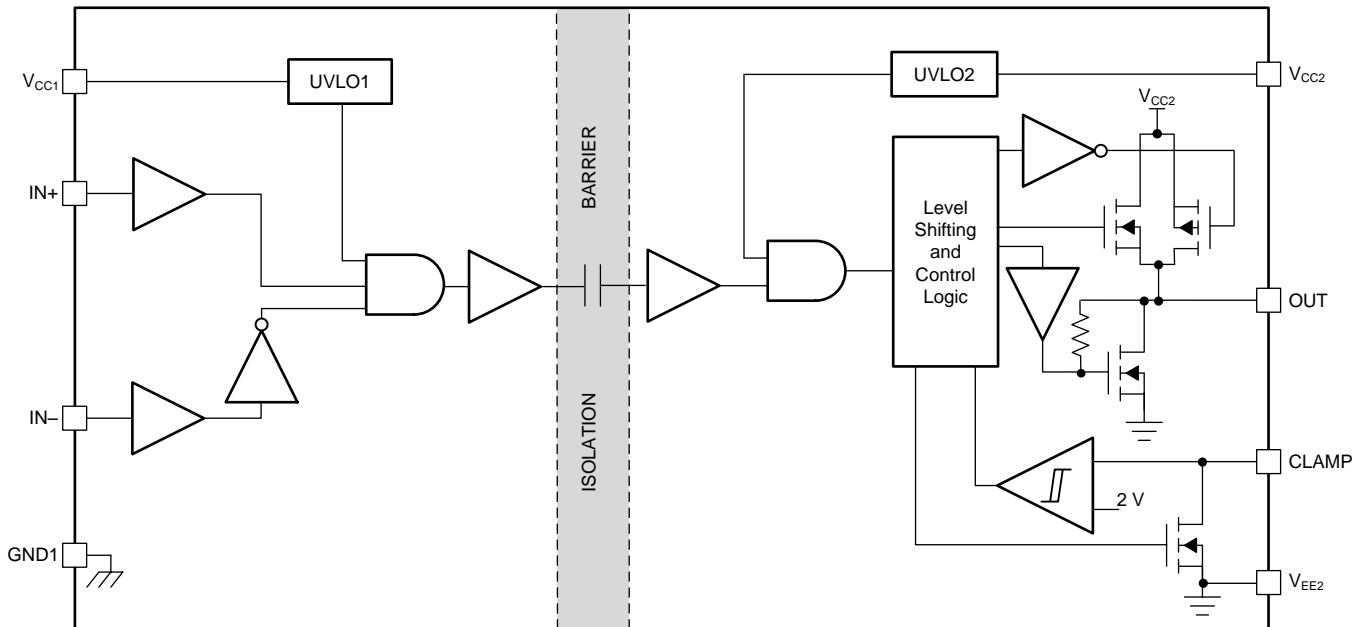

Figure 24. Functional Block Diagram—UCC5310M Miller Clamp

Functional Block Diagram (continued)

Figure 25. Functional Block Diagram—UCC5320E UVLO With Respect to GND2
8.3 Feature Description

Table 1 provides an overview of the device features.

Table 1. Device Features

PART NUMBER ⁽¹⁾	MINIMUM SOURCE CURRENT	MINIMUM SINK CURRENT	PIN CONFIGURATION	PACKAGE	ISOLATION RATING
UCC5310M	2.4 A	1.2 A	Miller clamp	D	3 kV _{RMS}
UCC5320E	2.4 A	2.3 A	UVLO with reference to GND2	D	3 kV _{RMS}
UCC5320S	2.4 A	2.3 A	Split output	D	3 kV _{RMS}

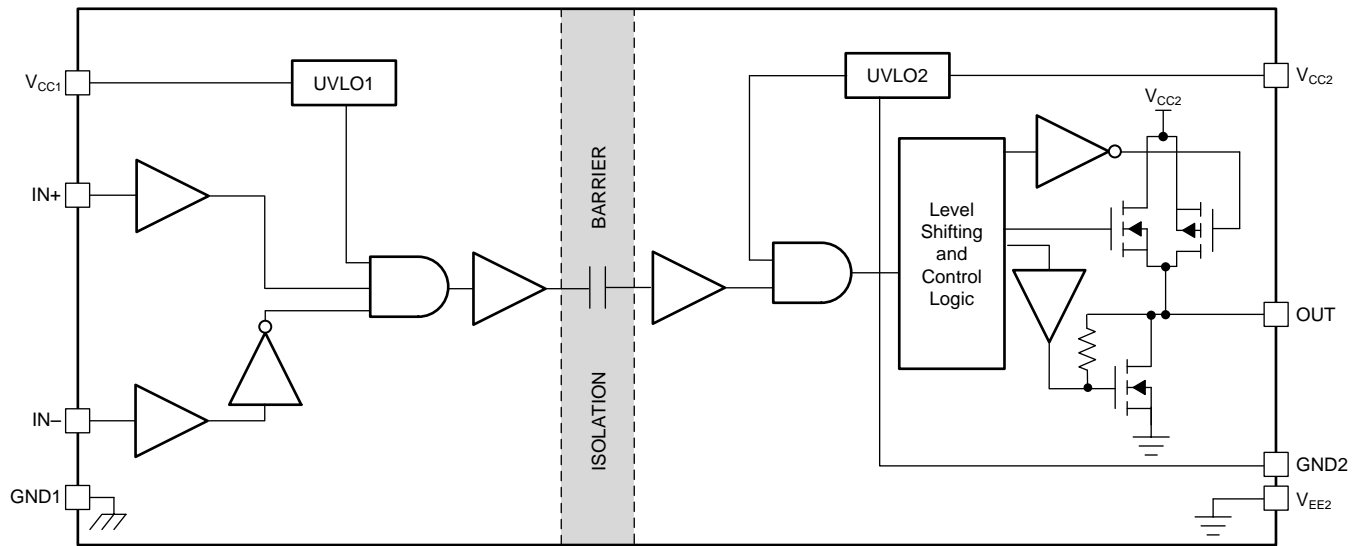
(1) The S, E, and M suffixes are part of the orderable part number. See the [Mechanical, Packaging, and Orderable Information](#) section for the full orderable part number.

8.3.1 Power Supply

The V_{CC1} input power supply supports a wide voltage range from 3 V to 15 V and the V_{CC2} output supply supports a voltage range from 13.2 V to 33 V. For operation with bipolar supplies, the power device is turned off with a negative voltage on the gate with respect to the emitter or source. This configuration prevents the power device from unintentionally turning on because of current induced from the Miller effect. The typical values of the V_{CC2} and V_{EE2} output supplies for bipolar operation are 15 V and -8 V with respect to GND2 for IGBTs, and 20 V and -5 V for SiC MOSFETs.

For operation with unipolar supply, the V_{CC2} supply is connected to 15 V with respect to GND2 for IGBTs, and 20 V for SiC MOSFETs. The V_{EE2} supply is connected to 0 V. In this use case, the UCC53x0 device with Miller clamping function (UCC53x0M) can be used. The Miller clamping function is implemented by adding a low impedance path between the gate of the power device and the V_{EE2} supply. Miller current can sink and the gate voltage is clamped to be lower than the turnon threshold value for the gate.

8.3.2 Input Stage

The input pins (IN+ and IN–) of UCC53x0 family are based on CMOS-compatible input-threshold logic that is completely isolated from the V_{CC2} supply voltage. The input pins are easy to drive with logic-level control signals (such as those from 3.3-V microcontrollers) because the UCC53x0 family has a typical high threshold ($V_{IT+(IN)}$) of $0.56 \times V_{CC1}$ and a typical low threshold of $0.45 \times V_{CC1}$. A wide hysteresis ($V_{hys(IN)}$) of $0.1 \times V_{CC1}$ makes for good noise immunity and stable operation. If any of the inputs are left open, 128 k Ω of internal pulldown resistance forces the IN+ pin low and 128 k Ω of internal resistance pulls IN– high. However, TI still recommends grounding an input if it is not being used for improved noise immunity.

Because the input side of the UCC53x0 family is isolated from the output driver, the input signal amplitude can be larger or smaller than V_{CC2} provided that it does not exceed the recommended limit. This feature allows greater flexibility when integrating the gate-driver with control signal sources, and allows the user to choose the most efficient V_{CC2} for any gate. However, the amplitude of any signal applied to IN+ or IN– must never be at a voltage higher than V_{CC1} .

8.3.3 Output Stage

The output stages of the UCC53x0 family feature a pullup structure that delivers the highest peak-source current when it is most needed which is during the Miller plateau region of the power-switch turnon transition (when the power-switch drain or collector voltage experiences dV/dt). The output stage pullup structure features a P-channel MOSFET and an additional pullup N-channel MOSFET in parallel. The function of the N-channel MOSFET is to provide a brief boost in the peak-sourcing current, enabling fast turnon. Fast turnon is accomplished by briefly turning on the N-channel MOSFET during a narrow instant when the output is changing states from low to high. The on-resistance of this N-channel MOSFET (R_{NMOS}) is approximately 4.5 Ω when activated. lists the typical internal-resistance values of the pullup and pulldown structure.

Table 2. UCC53x0 On-Resistance

PART NUMBER	R_{NMOS}	R_{OH}	R_{OL}	R_{CLAMP}	UNIT
UCC5320S and UCC5320E	4.5	12	0.65	Not applicable	Ω
UCC5310M	4.5	12	1.3	1.3	Ω

The R_{OH} parameter is a DC measurement and is representative of the on-resistance of the P-channel device only. This parameter is only for the P-channel device because the pullup N-channel device is held in the OFF state in DC condition and is turned on only for a brief instant when the output is changing states from low to high. Therefore, the effective resistance of the UCC53x0 pullup stage during this brief turnon phase is much lower than what is represented by the R_{OH} parameter, yielding a faster turnon. The turnon-phase output resistance is the parallel combination $R_{OH} \parallel R_{NMOS}$.

The pulldown structure in the UCC53x0 S and E versions is simply composed of an N-channel MOSFET. For the M version, an additional FET is connected in parallel with the pulldown structure when the CLAMP and OUT pins are connected to the gate of the IGBT or MOSFET. The output of the UCC53x0 family is capable of delivering, or sinking, 2-A, 5-A and 10-A peak current pulses. The output voltage swing between V_{CC2} and V_{EE2} provides rail-to-rail operation because of the MOS-out stage which delivers very low dropout.

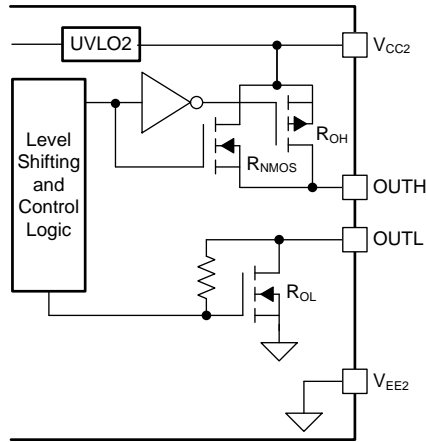

Figure 26. Output Stage—S Version

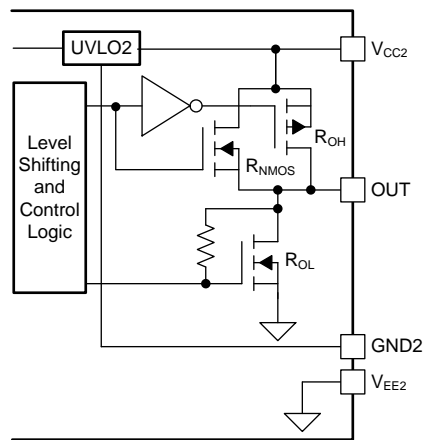

Figure 27. Output Stage—E Version

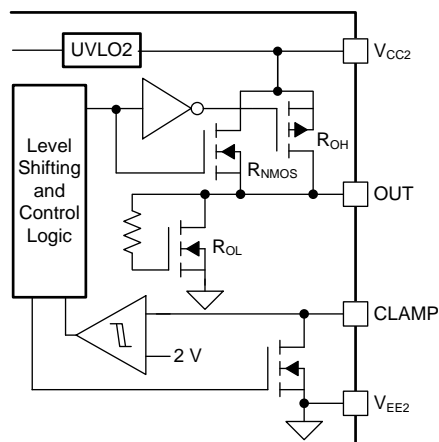

Figure 28. Output Stage—M Version

8.3.4 Protection Features

8.3.4.1 Undervoltage Lockout (UVLO)

UVLO functions are implemented for both the V_{CC1} and V_{CC2} supplies between the V_{CC1} and GND1, and V_{CC2} and V_{EE2} pins to prevent an underdriven condition on IGBTs and MOSFETs. When V_{CC} is lower than $V_{IT+(UVLO)}$ at device start-up or lower than $V_{IT-(UVLO)}$ after start-up, the voltage-supply UVLO feature holds the effected output low, regardless of the input pins (IN+ and IN–) as shown in Table 5. The V_{CC1} UVLO protection has a hysteresis feature ($V_{hys(UVLO1)}$). This hysteresis prevents chatter when the power supply produces ground noise which allows the device to permit small drops in bias voltage, which occurs when the device starts switching and operating current consumption increases suddenly. Figure 29 shows the UVLO functions.

Table 3. UCC53x0 V_{CC1} UVLO Logic

CONDITION	INPUTS		OUTPUTS	
	IN+	IN–	OUT, OUTH	OUTL
$V_{CC1} - GND1 < V_{IT+(UVLO1)}$ during device start-up	H	L	L	L
	L	H	L	L
	H	H	L	L
	L	L	L	L
$V_{CC1} - GND1 < V_{IT-(UVLO1)}$ during device start-up	H	L	L	L
	L	H	L	L
	H	H	L	L
	L	L	L	L

Table 4. UCC53x0 V_{CC2} UVLO Logic

CONDITION	INPUTS		OUTPUTS	
	IN+	IN–	OUT, OUTH	OUTL
$V_{CC2} - V_{EE2} < V_{IT+(UVLO2)}$ during device start-up	H	L	L	L
	L	H	L	L
	H	H	L	L
	L	L	L	L
$V_{CC2} - V_{EE2} < V_{IT-(UVLO2)}$ during device start-up	H	L	L	L
	L	H	L	L
	H	H	L	L
	L	L	L	L

When the output stages of the driver are in an unbiased or UVLO condition, the driver outputs are held low by an active clamp circuit that limits the voltage rise on the driver outputs. In this condition, the upper PMOS is resistively held off by a pullup resistor while the lower NMOS gate is tied to the driver output through a 500-k Ω resistor. In this configuration, the output is effectively clamped to the threshold voltage of the lower NMOS device which is typically less than 1.5 V when no bias power is available.

When V_{CC1} or V_{CC2} drops below the UVLO1 or UVLO2 threshold, a delay, t_{UVLO1_rec} or t_{UVLO2_rec} , occurs on the output when the supply voltage rises above $V_{IT+(UVLO)}$ or $V_{IT+(UVLO2)}$ again. Figure 29 and Figure 30 show this delay.

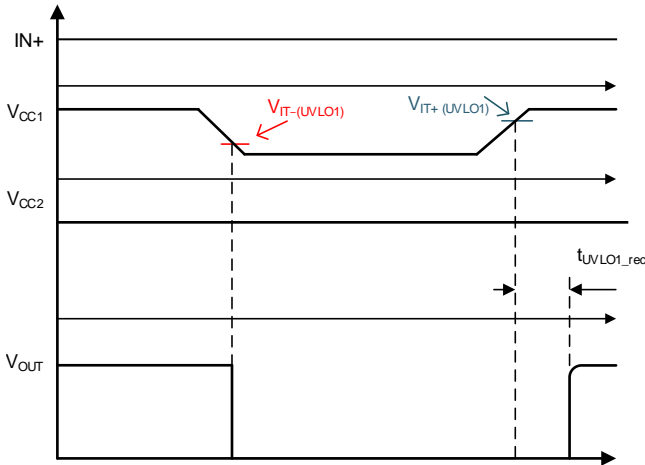

Figure 29. UVLO1 Functions

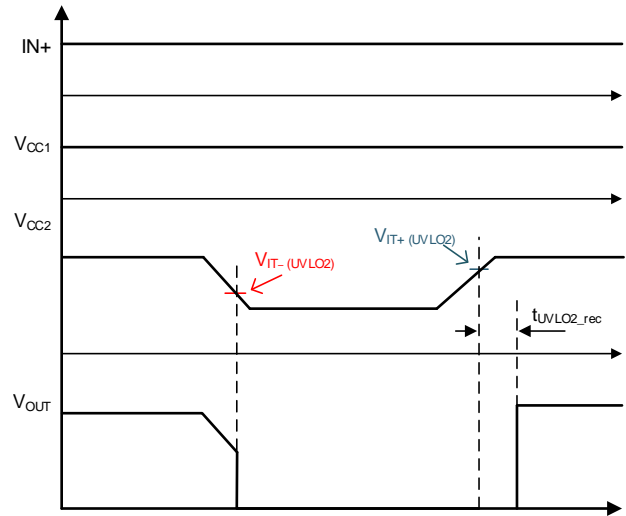

Figure 30. UVLO2 Functions

8.3.4.2 Active Pulldown

The active pulldown function is used to pull the IGBT or MOSFET gate to the low state when no power is connected to the V_{CC2} supply. This feature prevents false IGBT and MOSFET turnon on the OUT, OUTL, and CLAMP pins by clamping the output to approximately 2 V.

8.3.4.3 Short-Circuit Clamping

The short-circuit clamping function is used to clamp voltages at the driver output and pull the active Miller clamp pins slightly higher than the V_{CC2} voltage during short-circuit conditions. The short-circuit clamping function helps protect the IGBT or MOSFET gate from overvoltage breakdown or degradation. The short-circuit clamping function is implemented by adding a diode connection between the dedicated pins and the V_{CC2} pin inside the driver. The internal diodes can conduct up to 500-mA current for a duration of 10 μ s and a continuous current of 20 mA. Use external Schottky diodes to improve current conduction capability as needed.

8.3.4.4 Active Miller Clamp (UCC53x0M)

The active Miller-clamp function is used to prevent false turnon of the power switches caused by Miller current in applications where a unipolar power supply is used. The active Miller-clamp function is implemented by adding a low impedance path between the power-switch gate terminal and ground (V_{EE2}) to sink the Miller current. With the Miller-clamp function, the power-switch gate voltage is clamped to less than 2 V during the off state. [Figure 34](#) shows a typical application circuit of UCC5310M.

8.4 Device Functional Modes

[Table 5](#) lists the functional modes for the UCC53x0 devices.

Table 5. Function Table⁽¹⁾

V_{CC1}	V_{CC2}	IN+	IN-	OUTH, OUTL
PU	PD	X	X	Low
PD	PU	X	X	Low
PU	PU	Low	X	Low
PU	PU	X	High	Low
PU	PU	High	Low	High

(1) PU = Powered up ($V_{CC1} \geq 2.8$ V or $V_{CC2} \geq 13$ V); PD = Powered down ($V_{CC1} \leq 2.4$ V or $V_{CC2} \leq 10.3$ V); X = Irrelevant

8.4.1 Device I/O

Figure 31 shows the input and output structure of the UCC53x0 family of isolated gate drivers.

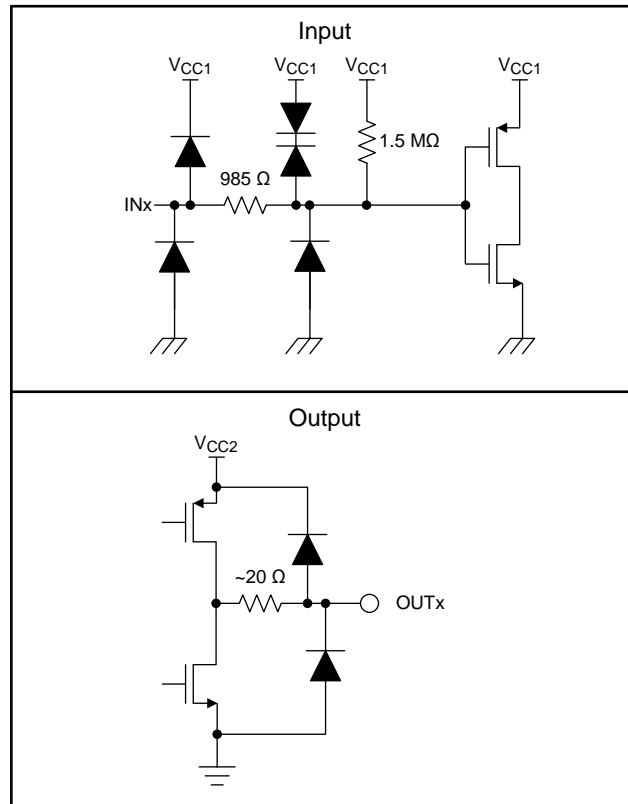

Figure 31. Device Input and Output Structure

8.4.2 ESD Structure

Figure 32 shows the multiple diodes involved in the ESD protection components of the UCC53x0 family. This provides pictorial representation of the absolute maximum rating for the device.

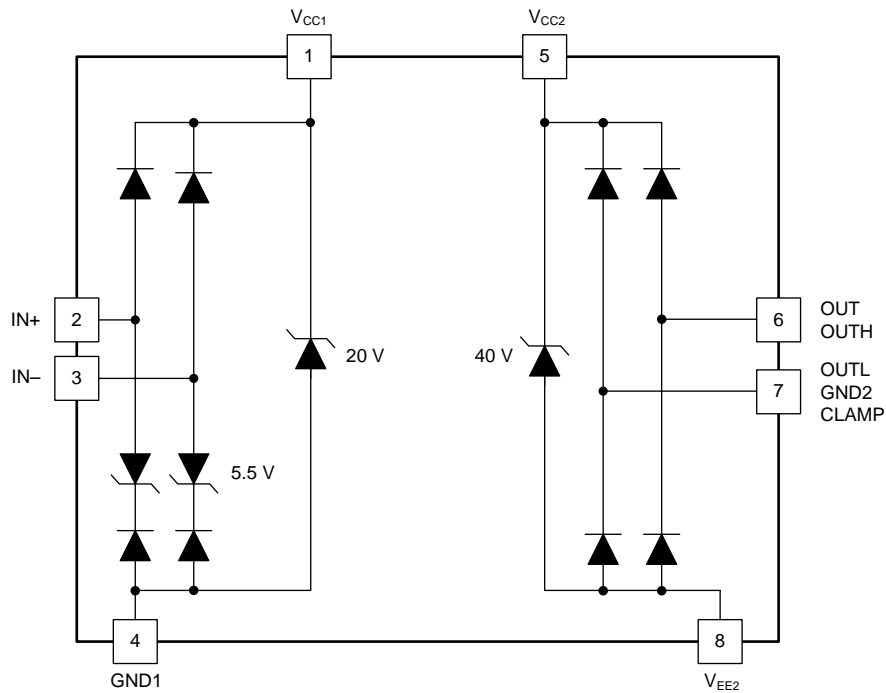

Figure 32. ESD Structure

9 Application and Implementation

NOTE

Information in the following applications sections is not part of the TI component specification, and TI does not warrant its accuracy or completeness. TI's customers are responsible for determining suitability of components for their purposes. Customers should validate and test their design implementation to confirm system functionality.

9.1 Application Information

The UCC53x0 is a family of simple, isolated gate drivers for power semiconductor devices, such as MOSFETs, IGBTs, or SiC MOSFETs. The family of devices is intended for use in applications such as motor control, industrial inverters, and switched-mode power supplies.

The UCC53x0 family of devices has three pinout configurations, featuring split outputs, Miller clamp, and UVLO with reference to GND2. The UCC5320S has two outputs, which are OUTH and OUTL. The two outputs can be used to separately decouple the power transistor turnon and turnoff commutations. The UCC5310M feature active Miller clamping, which can be used to prevent false turnon of the power transistors induced by the Miller current. The UCC5320E offer true UVLO protection by monitoring the voltage between the V_{CC2} and GND2 pins to prevent the power transistors from operating in a saturation region. The UCC53x0 family of devices comes in an 8-pin D package option and has a creepage, or clearance, of 4 mm, which is suitable for applications where basic isolation is required. Different drive strengths enable a simple driver platform to be used for applications demanding power transistors with different power ratings.

9.2 Typical Application

The circuits in [Figure 33](#), [Figure 34](#), and [Figure 35](#) show a typical application for driving IGBTs.

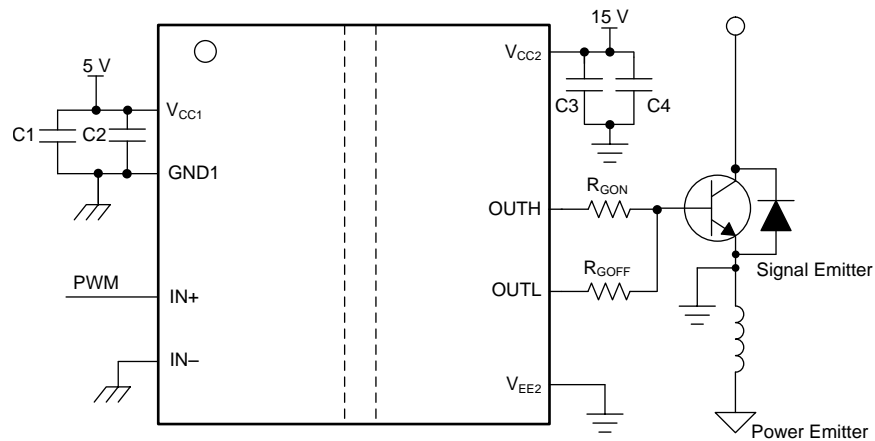

Copyright © 2017, Texas Instruments Incorporated

Figure 33. Typical Application Circuit for UCC5320S to Drive IGBT

Typical Application (continued)

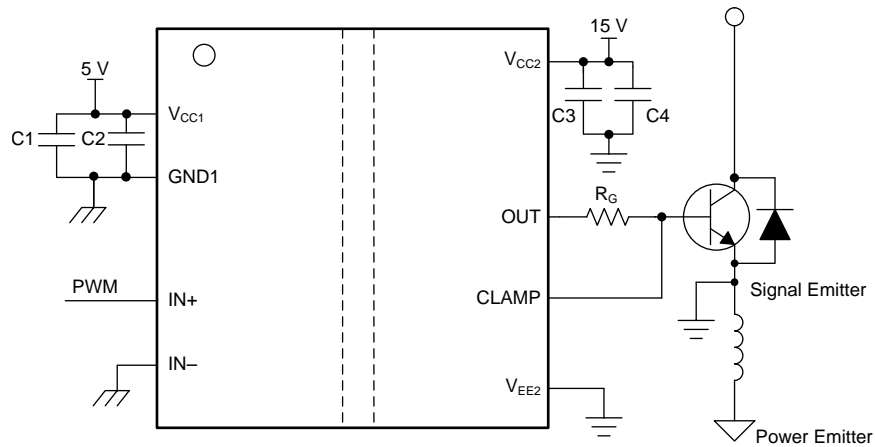

Copyright © 2017, Texas Instruments Incorporated

Figure 34. Typical Application Circuit for UCC5310M to Drive IGBT

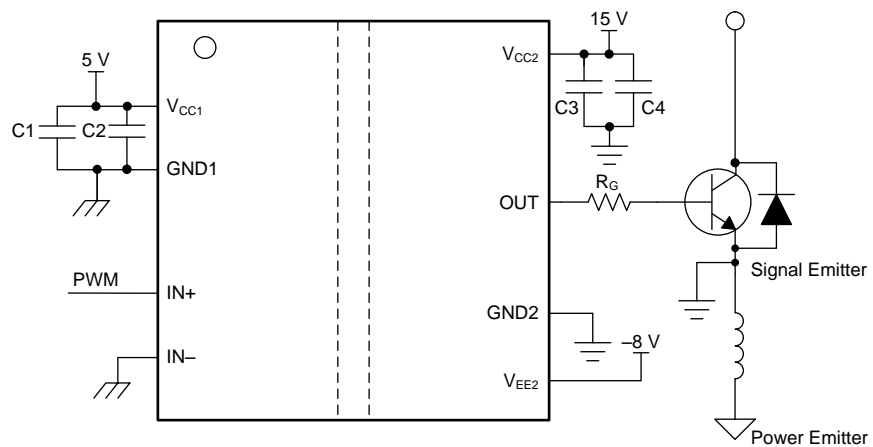

Copyright © 2017, Texas Instruments Incorporated

Figure 35. Typical Application Circuit for UCC5320E to Drive IGBT

9.2.1 Design Requirements

Table 6 lists the recommended conditions to observe the input and output of the UCC5320S split-output gate driver with the IN- pin tied to the GND1 pin.

Table 6. UCC5320S Design Requirements

PARAMETER	VALUE	UNIT
V _{CC1}	5	V
V _{CC2}	20	V
IN+	5	V _{PP}
IN-	GND1	V
Switching frequency	1	kHz

9.2.2 Detailed Design Procedure

9.2.2.1 Designing IN+ and IN– Input Filter

TI recommends that users avoid shaping the signals to the gate driver in an attempt to slow down (or delay) the signal at the output. However, a small input filter, R_{IN} - C_{IN} , can be used to filter out the ringing introduced by nonideal layout or long PCB traces.

Such a filter should use an R_{IN} resistor with a value from 0 Ω to 100 Ω and a C_{IN} capacitor with a value from 10 pF to 100 pF. In the example, the selected value for R_{IN} is 51 Ω and C_{IN} is 33 pF, with a corner frequency of approximately 100 MHz.

When selecting these components, pay attention to the trade-off between good noise immunity and propagation delay.

9.2.2.2 Gate-Driver Output Resistor

The external gate-driver resistors, $R_{G(ON)}$ and $R_{G(OFF)}$ are used to:

1. Limit ringing caused by parasitic inductances and capacitances
2. Limit ringing caused by high voltage or high current switching dv/dt , di/dt , and body-diode reverse recovery
3. Fine-tune gate drive strength, specifically peak sink and source current to optimize the switching loss
4. Reduce electromagnetic interference (EMI)

The UCC53x0 devices have similar pullup structures but S and E variations have different pulldown circuits than the M version as described in the [Output Stage](#) section. The output stage has a pullup structure consisting of a P-channel MOSFET and an N-channel MOSFET in parallel. The combined peak source current is 4.3 A for the UCC5320 family. Use [Equation 1](#) to estimate the peak source current using the UCC5320S as an example.

$$I_{OH} = \min \left(4.3 \text{ A}, \frac{V_{CC2}}{R_{NMOS} \parallel R_{OH} + R_{ON} + R_{GFET_Int}} \right)$$

where

- R_{ON} is the external turnon resistance.
- R_{GFET_Int} is the power transistor internal gate resistance, found in the power transistor data sheet.
- I_{OH} is the peak source current which is the minimum value between 4.3 A, the gate-driver peak source current, and the calculated value based on the gate-drive loop resistance. (1)

In this example, the peak source current is approximately 1.7 A as calculated in [Equation 2](#).

$$I_{OH} = \frac{V_{CC2}}{R_{NMOS} \parallel R_{OH} + R_{ON} + R_{GFET_Int}} = \frac{20 \text{ V}}{4.5 \Omega \parallel 12 \Omega + 2.2 \Omega + 1.5 \Omega} \approx 1.7 \text{ A} \quad (2)$$

Similarly, use [Equation 3](#) to calculate the peak sink current.

$$I_{OL} = \min \left(4.4 \text{ A}, \frac{V_{CC2}}{R_{OL} + R_{OFF} + R_{GFET_Int}} \right)$$

where

- R_{OFF} is the external turnoff resistance.
- I_{OL} is the peak sink current which is the minimum value between 4.4 A, the gate-driver peak sink current, and the calculated value based on the gate-drive loop resistance. (3)

In this example, the peak sink current is the minimum of [Equation 4](#) and 4.4 A.

$$I_{OL} = \frac{V_{CC2}}{R_{OL} + R_{OFF} + R_{GFET_Int}} = \frac{20 \text{ V}}{0.65 \Omega + 0 \Omega + 1.5 \Omega} \approx 9.3 \text{ A} \quad (4)$$

NOTE

The estimated peak current is also influenced by PCB layout and load capacitance. Parasitic inductance in the gate-driver loop can slow down the peak gate-drive current and introduce overshoot and undershoot. Therefore, TI strongly recommends that the gate-driver loop should be minimized. Conversely, the peak source and sink current is dominated by loop parasitics when the load capacitance (C_{ISS}) of the power transistor is very small (typically less than 1 nF) because the rising and falling time is too small and close to the parasitic ringing period.

9.2.2.3 Estimate Gate-Driver Power Loss

The total loss, P_G , in the gate-driver subsystem includes the power losses (P_{GD}) of the UCC53x0 device and the power losses in the peripheral circuitry, such as the external gate-drive resistor.

The P_{GD} value is the key power loss which determines the thermal safety-related limits of the UCC53x0 device, and it can be estimated by calculating losses from several components.

The first component is the static power loss, P_{GDQ} , which includes quiescent power loss on the driver as well as driver self-power consumption when operating with a certain switching frequency. The P_{GDQ} parameter is measured on the bench with no load connected to the OUT or OUTH and OUTL pins at a given V_{CC1} , V_{CC2} , switching frequency, and ambient temperature. In this example, V_{CC1} is 5 V and V_{CC2} is 20 V. The current on each power supply, with PWM switching from 0 V to 3.3 V at 1 kHz, is measured to be $I_{CC1} = 1.67$ mA and $I_{CC2} = 1.11$ mA. Therefore, use [Equation 5](#) to calculate P_{GDQ} .

$$P_{GDQ} = V_{CC1} \times I_{VCC1} + V_{CC2} \times I_{CC2} \approx 31 \text{ mW} \quad (5)$$

The second component is the switching operation loss, P_{GDO} , with a given load capacitance which the driver charges and discharges the load during each switching cycle. Use [Equation 6](#) to calculate the total dynamic loss from load switching, P_{GSW} .

$$P_{GSW} = 2 \times V_{CC2} \times Q_G \times f_{SW}$$

where

- Q_G is the gate charge of the power transistor at V_{CC2} . (6)

If a split rail is used for turn-on and turnoff, then V_{CC2} is the total difference between the positive rail to the negative rail.

So, for this example application the total dynamic loss from load switching is approximately 4 mW as calculated in [Equation 7](#).

$$P_{GSW} = 2 \times 20 \text{ V} \times 100 \text{ nC} \times 1 \text{ kHz} = 4 \text{ mW} \quad (7)$$

Q_G represents the total gate charge of the power transistor switching 400 V at 14 A, and is subject to change with different testing conditions. The UCC5320S gate-driver loss on the output stage, P_{GDO} , is part of P_{GSW} . P_{GDO} is equal to P_{GSW} if the external gate-driver resistance and power-transistor internal resistance are 0 Ω , and all the gate driver-loss will be dissipated inside the UCC5320S. If an external turnon and turnoff resistance exists, the total loss is distributed between the gate driver pullup and pulldown resistance, external gate resistance, and power-transistor internal resistance.

NOTE

The pullup or pulldown resistance is a linear and fixed resistance if the source or sink current is not saturated to 4.3 A or 4.4 A (respectively), however, the resistance is nonlinear if the source or sink current is saturated. Therefore, P_{GDO} is different in these two cases as follows.

Use [Equation 8](#) to calculate the linear pullup or pulldown resistor for case 1.

$$P_{GDO} = \frac{P_{GSW}}{2} \left(\frac{R_{OH} \parallel R_{NMOS}}{R_{OH} \parallel R_{NMOS} + R_{ON} + R_{GFET_Int}} + \frac{R_{OL}}{R_{OL} + R_{OFF} + R_{GFET_Int}} \right) \quad (8)$$

In this design example, all the predicted source and sink currents are less than 4.3 A and 4.4 A, therefore, use [Equation 9](#) to estimate the UCC53x0 gate-driver loss.

$$P_{GDO} = \frac{4 \text{ mW}}{2} \left(\frac{12 \Omega \parallel 4.5 \Omega}{12 \Omega \parallel 4.5 \Omega + 2.2 \Omega + 1.5 \Omega} + \frac{0.65 \Omega}{0.65 \Omega + 0 \Omega + 1.5 \Omega} \right) \approx 1.5 \text{ mW} \quad (9)$$

Use Equation 10 to calculate the nonlinear pullup or pulldown resistor for case 2.

$$P_{GDO} = 2 \times f_{SW} \times \left[4.3 \text{ A} \times \int_0^{T_{R_Sys}} (V_{CC2} - V_{OUTH}(t)) dt + 4.4 \text{ A} \times \int_0^{T_{F_Sys}} V_{OUTL}(t) dt \right]$$

where

- $V_{OUTH/L}(t)$ is the gate-driver OUTH and OUTL pin voltage during the turnon and turnoff period. In cases where the output is saturated for some time, this value can be simplified as a constant-current source (4.3 A at turnon and 4.4 A at turnoff) charging or discharging a load capacitor. Then, the $V_{OUTH/L}(t)$ waveform will be linear and the T_{R_Sys} and T_{F_Sys} can be easily predicted. (10)

For some scenarios, if only one of the pullup or pulldown circuits is saturated and another one is not, the P_{GDO} is a combination of case 1 and case 2, and the equations can be easily identified for the pullup and pulldown based on this discussion.

Use Equation 11 to calculate the total gate-driver loss dissipated in the UCC53x0 gate driver, P_{GD} .

$$P_{GD} = P_{GDQ} + P_{GDO} = 31 \text{ mW} + 1.5 \text{ mW} = 32.5 \text{ mW} \quad (11)$$

9.2.2.4 Estimating Junction Temperature

Use Equation 12 to estimate the junction temperature (T_J) of the UCC53x0 family.

$$T_J = T_C + \Psi_{JT} \times P_{GD}$$

where

- T_C is the UCC53x0 case-top temperature measured with a thermocouple or some other instrument.
- Ψ_{JT} is the junction-to-top characterization parameter from the [Thermal Information](#) table. (12)

Using the junction-to-top characterization parameter (Ψ_{JT}) instead of the junction-to-case thermal resistance ($R_{\theta JC}$) can greatly improve the accuracy of the junction temperature estimation. The majority of the thermal energy of most ICs is released into the PCB through the package leads, whereas only a small percentage of the total energy is released through the top of the case (where thermocouple measurements are usually conducted). The $R_{\theta JC}$ resistance can only be used effectively when most of the thermal energy is released through the case, such as with metal packages or when a heat sink is applied to an IC package. In all other cases, use of $R_{\theta JC}$ will inaccurately estimate the true junction temperature. The Ψ_{JT} parameter is experimentally derived by assuming that the amount of energy leaving through the top of the IC will be similar in both the testing environment and the application environment. As long as the recommended layout guidelines are observed, junction temperature estimations can be made accurately to within a few degrees Celsius.

9.2.3 Selecting V_{CC1} and V_{CC2} Capacitors

Bypass capacitors for the V_{CC1} and V_{CC2} supplies are essential for achieving reliable performance. TI recommends choosing low-ESR and low-ESL, surface-mount, multi-layer ceramic capacitors (MLCC) with sufficient voltage ratings, temperature coefficients, and capacitance tolerances.

NOTE

DC bias on some MLCCs will impact the actual capacitance value. For example, a 25-V, 1- μ F X7R capacitor is measured to be only 500 nF when a DC bias of 15- V_{DC} is applied.

9.2.3.1 Selecting a V_{CC1} Capacitor

A bypass capacitor connected to the V_{CC1} pin supports the transient current required for the primary logic and the total current consumption, which is only a few milliamperes. Therefore, a 50-V MLCC with over 100 nF is recommended for this application. If the bias power-supply output is located a relatively long distance from the V_{CC1} pin, a tantalum or electrolytic capacitor with a value greater than 1 μ F should be placed in parallel with the MLCC.

9.2.3.2 Selecting a V_{CC2} Capacitor

A 50-V, 10- μ F MLCC and a 50-V, 0.22- μ F MLCC are selected for the C_{VCC2} capacitor. If the bias power supply output is located a relatively long distance from the V_{CC2} pin, a tantalum or electrolytic capacitor with a value greater than 10 μ F should be used in parallel with C_{VCC2} .

9.2.3.3 Application Circuits With Output Stage Negative Bias

When parasitic inductances are introduced by nonideal PCB layout and long package leads (such as TO-220 and TO-247 type packages), ringing in the gate-source drive voltage of the power transistor could occur during high di/dt and dv/dt switching. If the ringing is over the threshold voltage, unintended turnon and shoot-through could occur. Applying a negative bias on the gate drive is a popular way to keep such ringing below the threshold. A few examples of implementing negative gate-drive bias follow.

Figure 36 shows the first example with negative bias turnoff on the output using a Zener diode on the isolated power-supply output stage. The negative bias is set by the Zener diode voltage. If the isolated power supply is equal to 25 V, the turnoff voltage is -5.1 V and the turnon voltage is $25\text{ V} - 5.1\text{ V} \approx 20\text{ V}$.

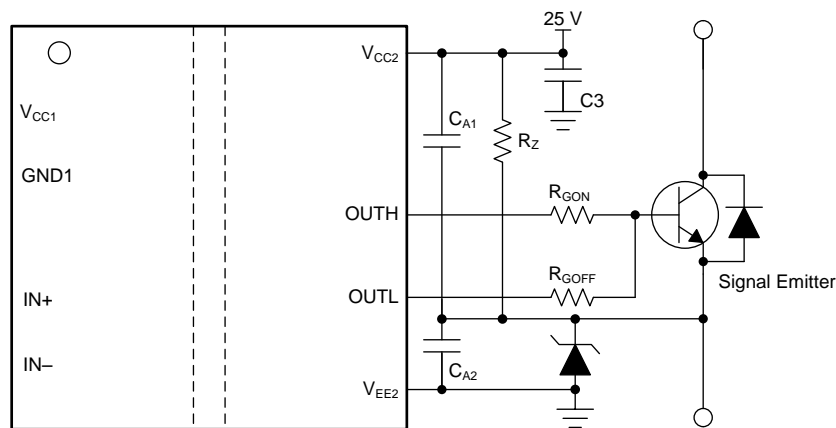

Copyright © 2017, Texas Instruments Incorporated

Figure 36. Negative Bias With Zener Diode on Iso-Bias Power-Supply Output (UCC5320S)

Figure 37 shows another example which uses two supplies (or single-input, double-output power supply). The power supply across V_{CC2} and GND2 determines the positive drive output voltage and the power supply across V_{EE2} and GND2 determines the negative turnoff voltage. This solution requires more power supplies than the first example, however, it provides more flexibility when setting the positive and negative rail voltages.

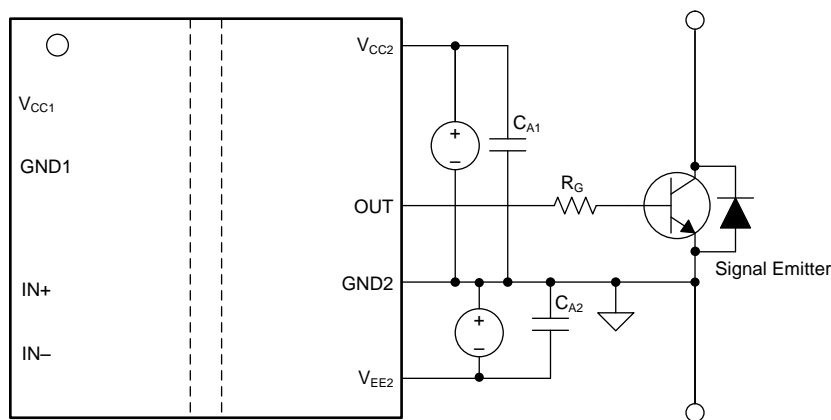

Copyright © 2017, Texas Instruments Incorporated

Figure 37. Negative Bias With Two Iso-Bias Power Supplies (UCC5320E)

9.2.4 Application Curve

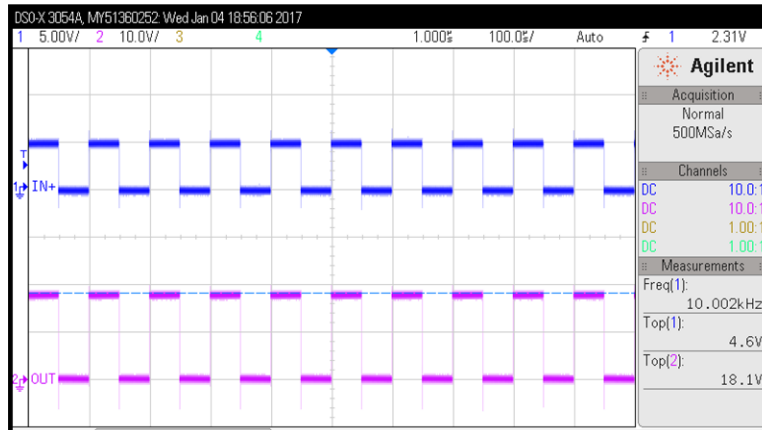

$$V_{CC2} = 20 \text{ V} \quad V_{EE2} = \text{GND} \quad f_{SW} = 10 \text{ kHz}$$

Figure 38. PWM Input And Gate Voltage Waveform

10 Power Supply Recommendations

The recommended input supply voltage (V_{CC1}) for the UCC53x0 device is from 3 V to 15 V. The lower limit of the range of output bias-supply voltage (V_{CC2}) is determined by the internal UVLO protection feature of the device. The V_{CC1} and V_{CC2} voltages should not fall below their respective UVLO thresholds for normal operation, or else the gate-driver outputs can become clamped low for more than 50 μs by the UVLO protection feature. For more information on UVLO, see the [Undervoltage Lockout \(UVLO\)](#) section). The higher limit of the V_{CC2} range depends on the maximum gate voltage of the power device that is driven by the UCC53x0 device, and should not exceed the recommended maximum V_{CC2} of 33 V. A local bypass capacitor should be placed between the V_{CC2} and V_{EE2} pins, with a value of 220-nF to 10- μF for device biasing. TI recommends placing an additional 100-nF capacitor in parallel with the device biasing capacitor for high frequency filtering. Both capacitors should be positioned as close to the device as possible. Low-ESR, ceramic surface-mount capacitors are recommended. Similarly, a bypass capacitor should also be placed between the V_{CC1} and GND1 pins. Given the small amount of current drawn by the logic circuitry within the input side of the UCC53x0 device, this bypass capacitor has a minimum recommended value of 100 nF.

If only a single, primary-side power supply is available in an application, isolated power can be generated for the secondary side with the help of a transformer driver such as Texas Instruments' [SN6501](#) or [SN6505A](#). For such applications, detailed power supply design and transformer selection recommendations are available in [SN6501 Transformer Driver for Isolated Power Supplies](#) and [SN6505A Low-Noise 1-A Transformer Drivers for Isolated Power Supplies](#).

11 Layout

11.1 Layout Guidelines

Designers must pay close attention to PCB layout to achieve optimum performance for the UCC53x0. Some key guidelines are:

- Component placement:
 - Low-ESR and low-ESL capacitors must be connected close to the device between the V_{CC1} and GND1 pins and between the V_{CC2} and V_{EE2} pins to bypass noise and to support high peak currents when turning on the external power transistor.
 - To avoid large negative transients on the V_{EE2} pins connected to the switch node, the parasitic inductances between the source of the top transistor and the source of the bottom transistor must be minimized.
- Grounding considerations:
 - Limiting the high peak currents that charge and discharge the transistor gates to a minimal physical area is essential. This limitation decreases the loop inductance and minimizes noise on the gate terminals of the transistors. The gate driver must be placed as close as possible to the transistors.
- High-voltage considerations:
 - To ensure isolation performance between the primary and secondary side, avoid placing any PCB traces or copper below the driver device. PCB cutting or scoring beneath the IC are not recommended because this can severely exacerbate board warping and twisting issues.
- Thermal considerations:
 - A large amount of power may be dissipated by the UCC53x0 if the driving voltage is high, the load is heavy, or the switching frequency is high (for more information, see the [Estimate Gate-Driver Power Loss](#) section). Proper PCB layout can help dissipate heat from the device to the PCB and minimize junction-to-board thermal impedance (θ_{JB}).
 - Increasing the PCB copper connecting to the V_{CC2} , GND1, and V_{EE2} pins is recommended, with priority on maximizing the connection to V_{EE2} . However, the previously mentioned high-voltage PCB considerations must be maintained.
 - If the system has multiple layers, TI also recommends connecting the V_{CC2} and V_{EE2} pins to internal ground or power planes through multiple vias of adequate size. These vias should be located close to the IC pins to maximize thermal conductivity. However, keep in mind that no traces or coppers from different high voltage planes are overlapping.

11.2 Layout Example

Figure 39 shows a PCB layout example with the signals and key components labeled.

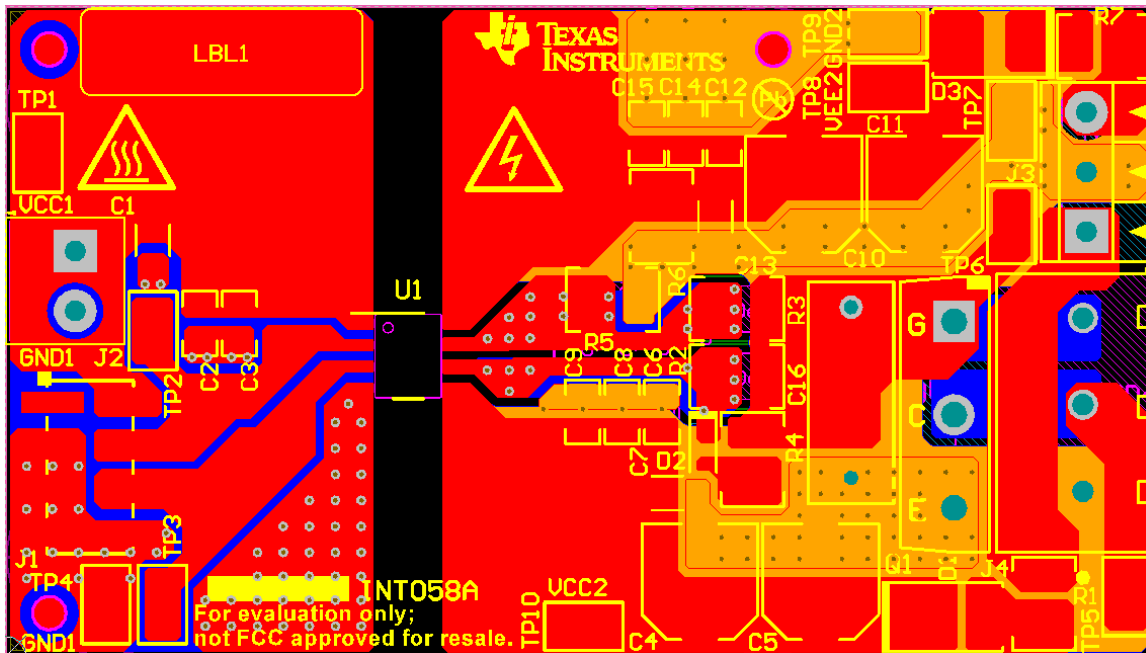

- (1) No PCB traces or copper are located between the primary and secondary side, which ensures isolation performance.

Figure 39. Layout Example

Layout Example (continued)

Figure 40 and Figure 41 show the top and bottom layer traces and copper.

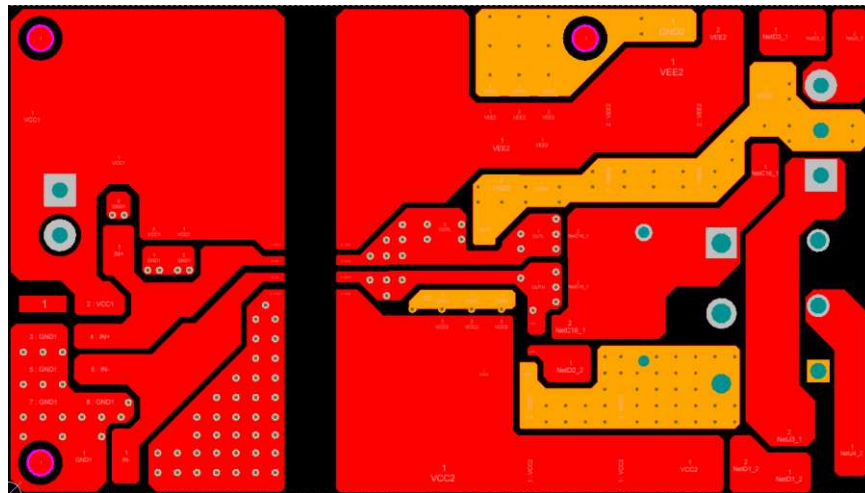

Figure 40. Top-Layer Traces and Copper

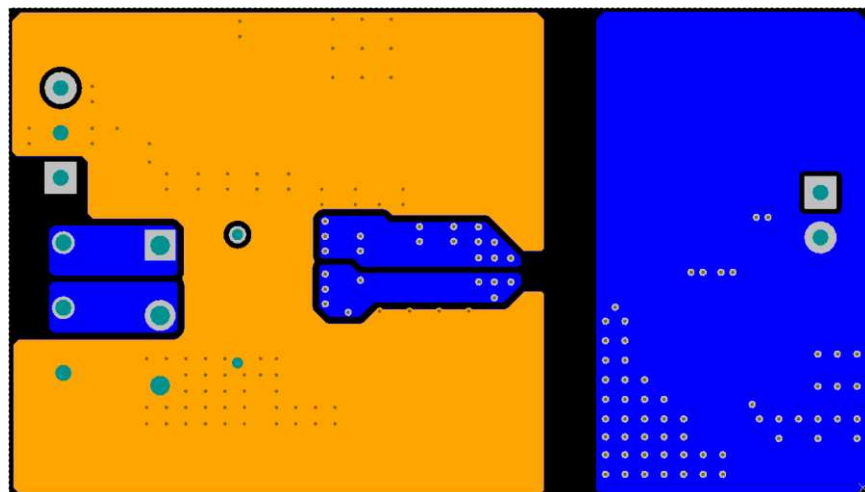
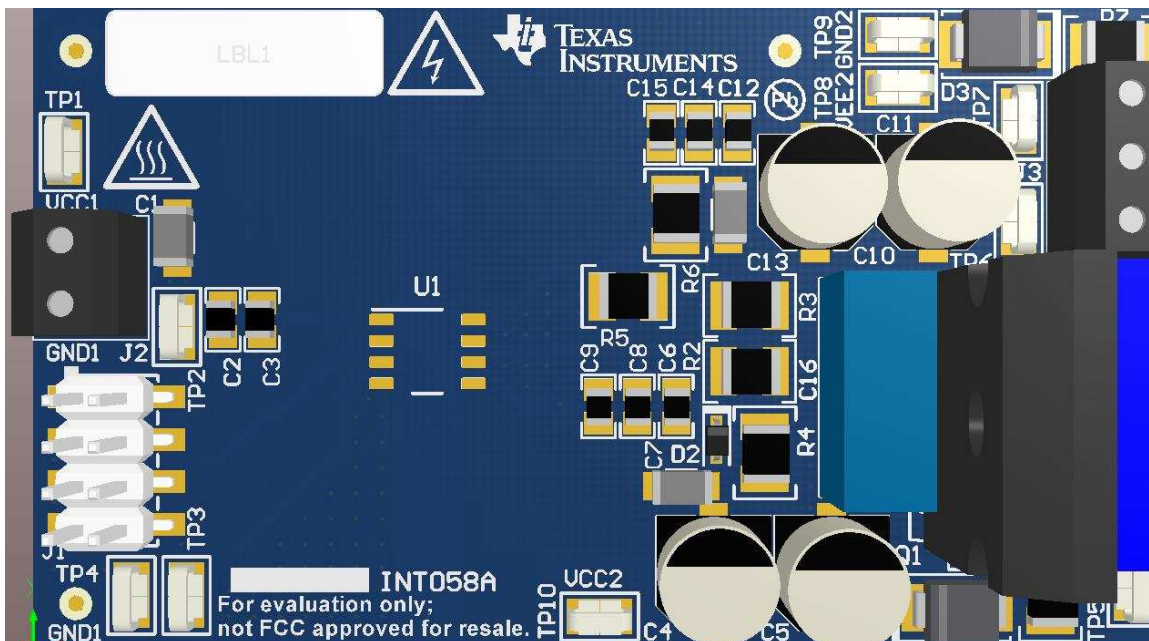

Figure 41. Bottom-Layer Traces and Copper (Flipped)

Layout Example (continued)

Figure 42 shows the 3D layout of the top view of the PCB.



(1) The location of the PCB cutout between primary side and secondary sides ensures isolation performance.

Figure 42. 3-D PCB View

11.3 PCB Material

Use standard FR-4 UL94V-0 printed circuit board. This PCB is preferred over cheaper alternatives because of lower dielectric losses at high frequencies, less moisture absorption, greater strength and stiffness, and the self-extinguishing flammability-characteristics.

Figure 43 shows the recommended layer stack.

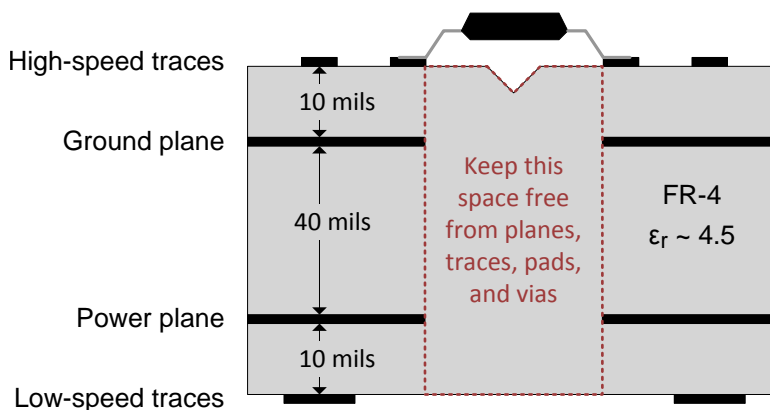

Figure 43. Recommended Layer Stack

12 Device and Documentation Support

12.1 Documentation Support

12.1.1 Related Documentation

For related documentation see the following:

- [Digital Isolator Design Guide](#)
- [Isolation Glossary](#)
- [SN6501 Transformer Driver for Isolated Power Supplies](#)
- [SN6505A Low-Noise 1-A Transformer Drivers for Isolated Power Supplies](#)

12.2 Related Links

The table below lists quick access links. Categories include technical documents, support and community resources, tools and software, and quick access to order now.

Table 7. Related Links

PARTS	PRODUCT FOLDER	ORDER NOW	TECHNICAL DOCUMENTS	TOOLS & SOFTWARE	SUPPORT & COMMUNITY
UCC5310	Click here	Click here	Click here	Click here	Click here
UCC5320	Click here	Click here	Click here	Click here	Click here

12.3 Receiving Notification of Documentation Updates

To receive notification of documentation updates, navigate to the device product folder on ti.com. In the upper right corner, click on *Alert me* to register and receive a weekly digest of any product information that has changed. For change details, review the revision history included in any revised document.

12.4 Community Resources

The following links connect to TI community resources. Linked contents are provided "AS IS" by the respective contributors. They do not constitute TI specifications and do not necessarily reflect TI's views; see TI's [Terms of Use](#).

TI E2E™ Online Community *TI's Engineer-to-Engineer (E2E) Community*. Created to foster collaboration among engineers. At e2e.ti.com, you can ask questions, share knowledge, explore ideas and help solve problems with fellow engineers.

Design Support *TI's Design Support* Quickly find helpful E2E forums along with design support tools and contact information for technical support.

12.5 Trademarks

E2E is a trademark of Texas Instruments.
All other trademarks are the property of their respective owners.

12.6 Electrostatic Discharge Caution



This integrated circuit can be damaged by ESD. Texas Instruments recommends that all integrated circuits be handled with appropriate precautions. Failure to observe proper handling and installation procedures can cause damage.

ESD damage can range from subtle performance degradation to complete device failure. Precision integrated circuits may be more susceptible to damage because very small parametric changes could cause the device not to meet its published specifications.

12.7 Glossary

SLYZ022 — *TI Glossary*.

This glossary lists and explains terms, acronyms, and definitions.

13 Mechanical, Packaging, and Orderable Information

The following pages include mechanical, packaging, and orderable information. This information is the most current data available for the designated devices. This data is subject to change without notice and revision of this document. For browser-based versions of this data sheet, refer to the left-hand navigation.

D0008B
PACKAGE OUTLINE
SOIC - 1.75 mm max height

SOIC

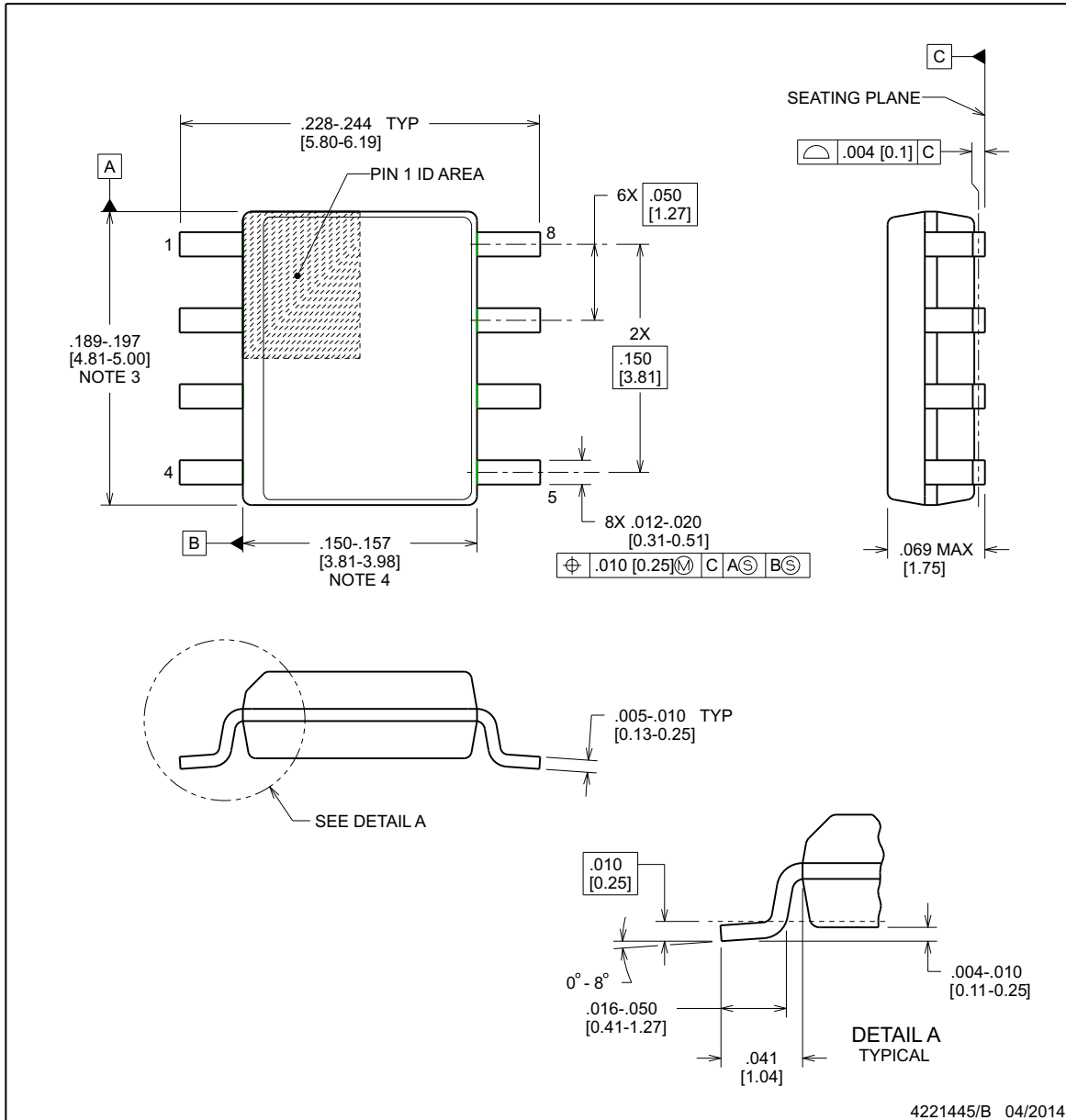
NOTES:

- Linear dimensions are in inches [millimeters]. Dimensions in parenthesis are for reference only. Controlling dimensions are in inches. Dimensioning and tolerancing per ASME Y14.5M.
- This drawing is subject to change without notice.
- This dimension does not include mold flash, protrusions, or gate burrs. Mold flash, protrusions, or gate burrs shall not exceed $.006$ [0.15], per side.
- This dimension does not include interlead flash.
- Reference JEDEC registration MS-012, variation AA.

EXAMPLE BOARD LAYOUT

D0008B

SOIC - 1.75 mm max height

SOIC

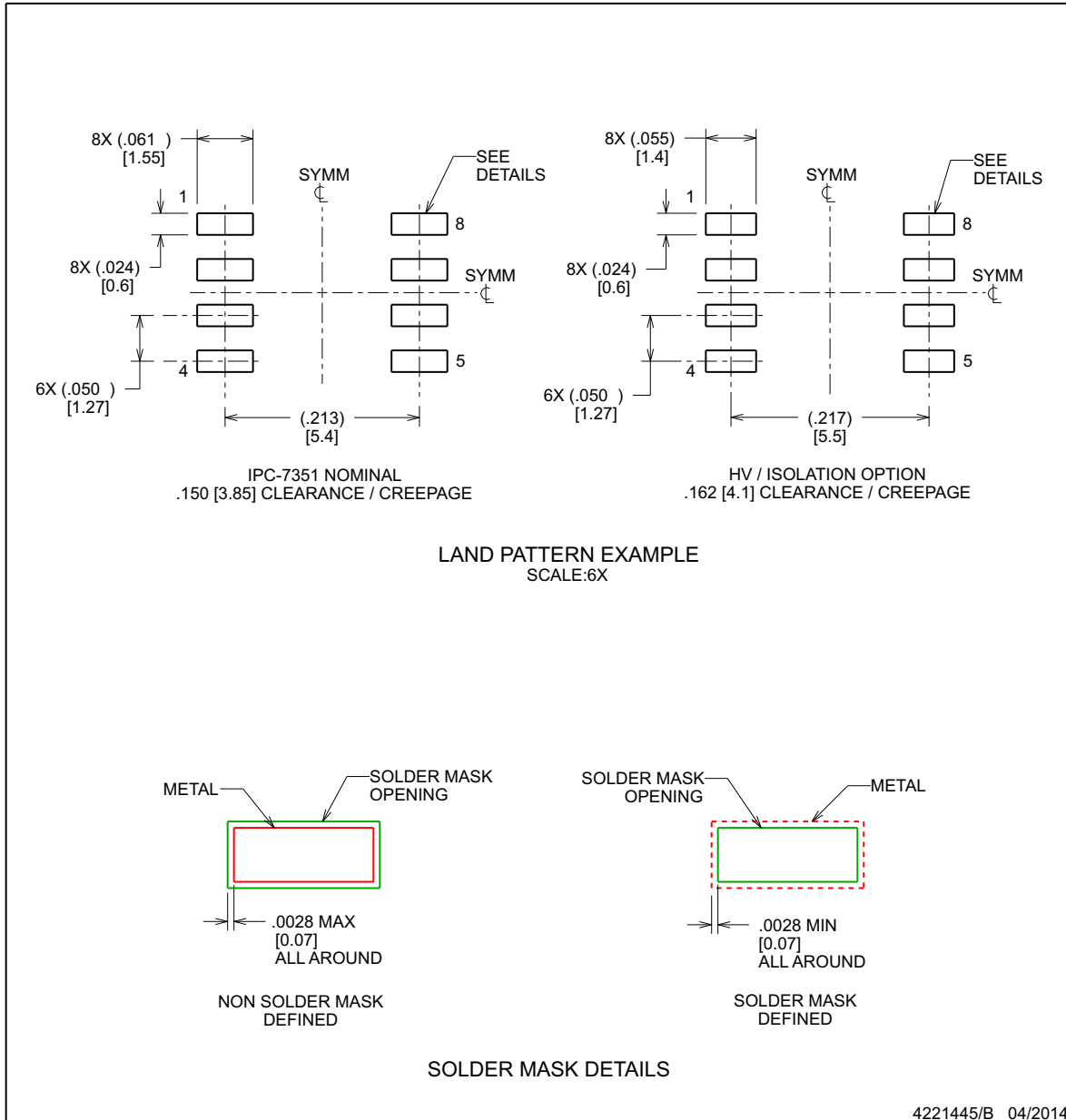

NOTES: (continued)

- 6. Publication IPC-7351 may have alternate designs.
- 7. Solder mask tolerances between and around signal pads can vary based on board fabrication site.

EXAMPLE STENCIL DESIGN

D0008B
SOIC - 1.75 mm max height

SOIC

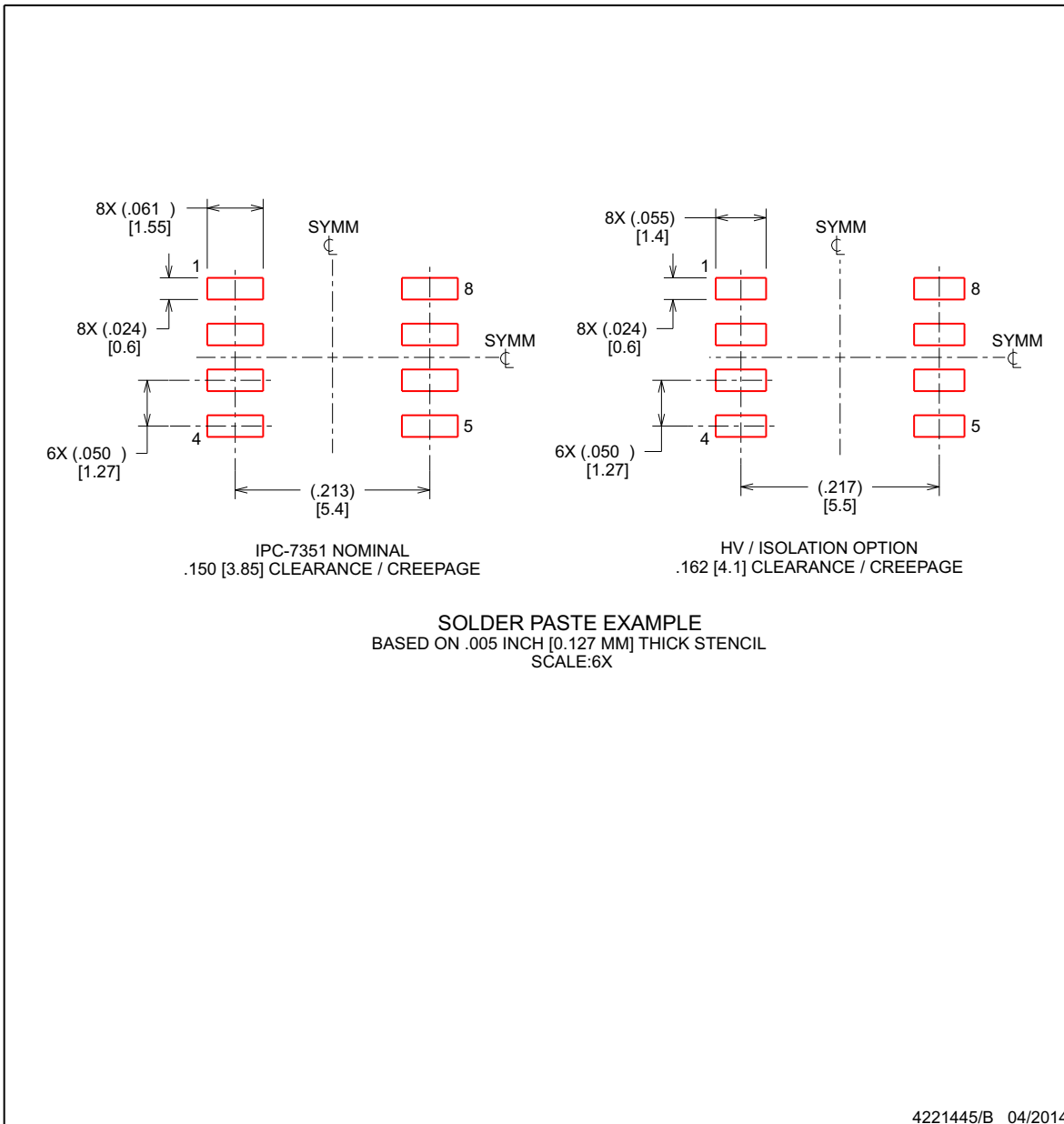

NOTES: (continued)

8. Laser cutting apertures with trapezoidal walls and rounded corners may offer better paste release. IPC-7525 may have alternate design recommendations.
9. Board assembly site may have different recommendations for stencil design.

PACKAGING INFORMATION

Orderable Device	Status (1)	Package Type	Package Drawing	Pins	Package Qty	Eco Plan (2)	Lead/Ball Finish (6)	MSL Peak Temp (3)	Op Temp (°C)	Device Marking (4/5)	Samples
UCC5310MCD	ACTIVE	SOIC	D	8	75	Green (RoHS & no Sb/Br)	CU NIPDAU	Level-2-260C-1 YEAR	-55 to 125	5310M	Samples
UCC5310MCDR	ACTIVE	SOIC	D	8	2500	Green (RoHS & no Sb/Br)	CU NIPDAU	Level-2-260C-1 YEAR	-55 to 125	5310M	Samples
UCC5320ECD	ACTIVE	SOIC	D	8	75	Green (RoHS & no Sb/Br)	CU NIPDAU	Level-2-260C-1 YEAR	-55 to 125	5320E	Samples
UCC5320ECDR	ACTIVE	SOIC	D	8	2500	Green (RoHS & no Sb/Br)	CU NIPDAU	Level-2-260C-1 YEAR	-55 to 125	5320E	Samples
UCC5320SCD	ACTIVE	SOIC	D	8	75	Green (RoHS & no Sb/Br)	CU NIPDAU	Level-2-260C-1 YEAR	-55 to 125	5320S	Samples
UCC5320SCDR	ACTIVE	SOIC	D	8	2500	Green (RoHS & no Sb/Br)	CU NIPDAU	Level-2-260C-1 YEAR	-55 to 125	5320S	Samples

(1) The marketing status values are defined as follows:

ACTIVE: Product device recommended for new designs.

LIFEBUY: TI has announced that the device will be discontinued, and a lifetime-buy period is in effect.

NRND: Not recommended for new designs. Device is in production to support existing customers, but TI does not recommend using this part in a new design.

PREVIEW: Device has been announced but is not in production. Samples may or may not be available.

OBSELETE: TI has discontinued the production of the device.

(2) **RoHS:** TI defines "RoHS" to mean semiconductor products that are compliant with the current EU RoHS requirements for all 10 RoHS substances, including the requirement that RoHS substance do not exceed 0.1% by weight in homogeneous materials. Where designed to be soldered at high temperatures, "RoHS" products are suitable for use in specified lead-free processes. TI may reference these types of products as "Pb-Free".

RoHS Exempt: TI defines "RoHS Exempt" to mean products that contain lead but are compliant with EU RoHS pursuant to a specific EU RoHS exemption.

Green: TI defines "Green" to mean the content of Chlorine (Cl) and Bromine (Br) based flame retardants meet JS709B low halogen requirements of <=1000ppm threshold. Antimony trioxide based flame retardants must also meet the <=1000ppm threshold requirement.

(3) MSL, Peak Temp. - The Moisture Sensitivity Level rating according to the JEDEC industry standard classifications, and peak solder temperature.

(4) There may be additional marking, which relates to the logo, the lot trace code information, or the environmental category on the device.

(5) Multiple Device Markings will be inside parentheses. Only one Device Marking contained in parentheses and separated by a "~" will appear on a device. If a line is indented then it is a continuation of the previous line and the two combined represent the entire Device Marking for that device.

⁽⁶⁾ Lead/Ball Finish - Orderable Devices may have multiple material finish options. Finish options are separated by a vertical ruled line. Lead/Ball Finish values may wrap to two lines if the finish value exceeds the maximum column width.

Important Information and Disclaimer:The information provided on this page represents TI's knowledge and belief as of the date that it is provided. TI bases its knowledge and belief on information provided by third parties, and makes no representation or warranty as to the accuracy of such information. Efforts are underway to better integrate information from third parties. TI has taken and continues to take reasonable steps to provide representative and accurate information but may not have conducted destructive testing or chemical analysis on incoming materials and chemicals. TI and TI suppliers consider certain information to be proprietary, and thus CAS numbers and other limited information may not be available for release.

In no event shall TI's liability arising out of such information exceed the total purchase price of the TI part(s) at issue in this document sold by TI to Customer on an annual basis.

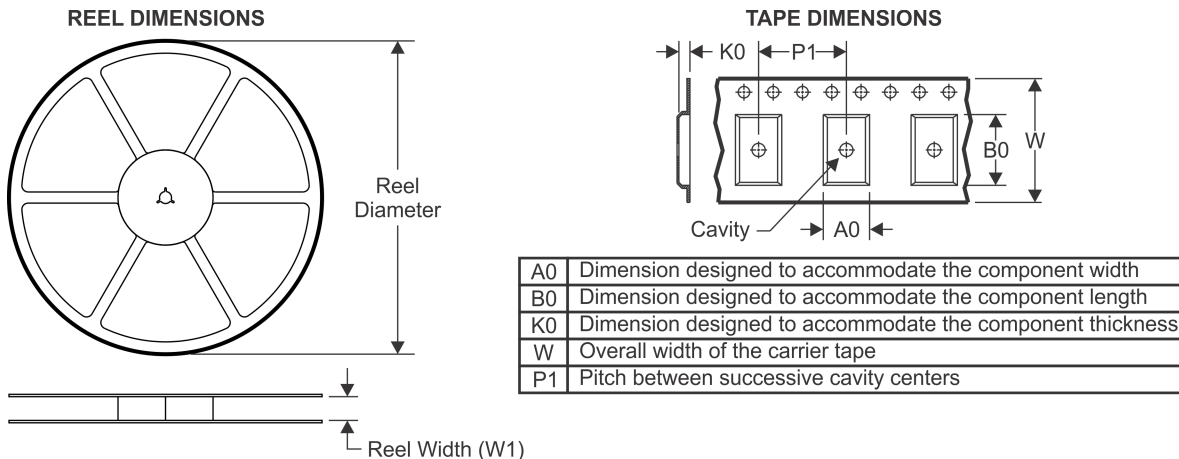
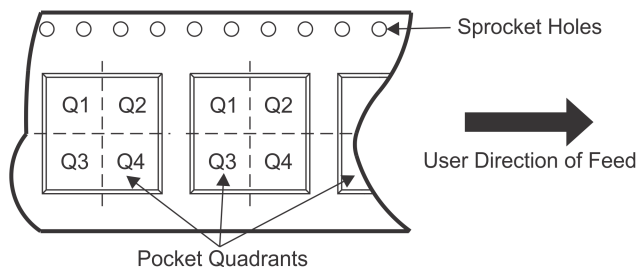
TAPE AND REEL INFORMATION

QUADRANT ASSIGNMENTS FOR PIN 1 ORIENTATION IN TAPE

*All dimensions are nominal

Device	Package Type	Package Drawing	Pins	SPQ	Reel Diameter (mm)	Reel Width W1 (mm)	A0 (mm)	B0 (mm)	K0 (mm)	P1 (mm)	W (mm)	Pin1 Quadrant
UCC5310MCDR	SOIC	D	8	2500	330.0	12.4	6.4	5.2	2.1	8.0	12.0	Q1
UCC5320ECDR	SOIC	D	8	2500	330.0	12.4	6.4	5.2	2.1	8.0	12.0	Q1
UCC5320SCDR	SOIC	D	8	2500	330.0	12.4	6.4	5.2	2.1	8.0	12.0	Q1

TAPE AND REEL BOX DIMENSIONS

*All dimensions are nominal

Device	Package Type	Package Drawing	Pins	SPQ	Length (mm)	Width (mm)	Height (mm)
UCC5310MCDR	SOIC	D	8	2500	367.0	367.0	38.0
UCC5320ECDR	SOIC	D	8	2500	367.0	367.0	38.0
UCC5320SCDR	SOIC	D	8	2500	367.0	367.0	38.0

D (R-PDSO-G8)

PLASTIC SMALL OUTLINE

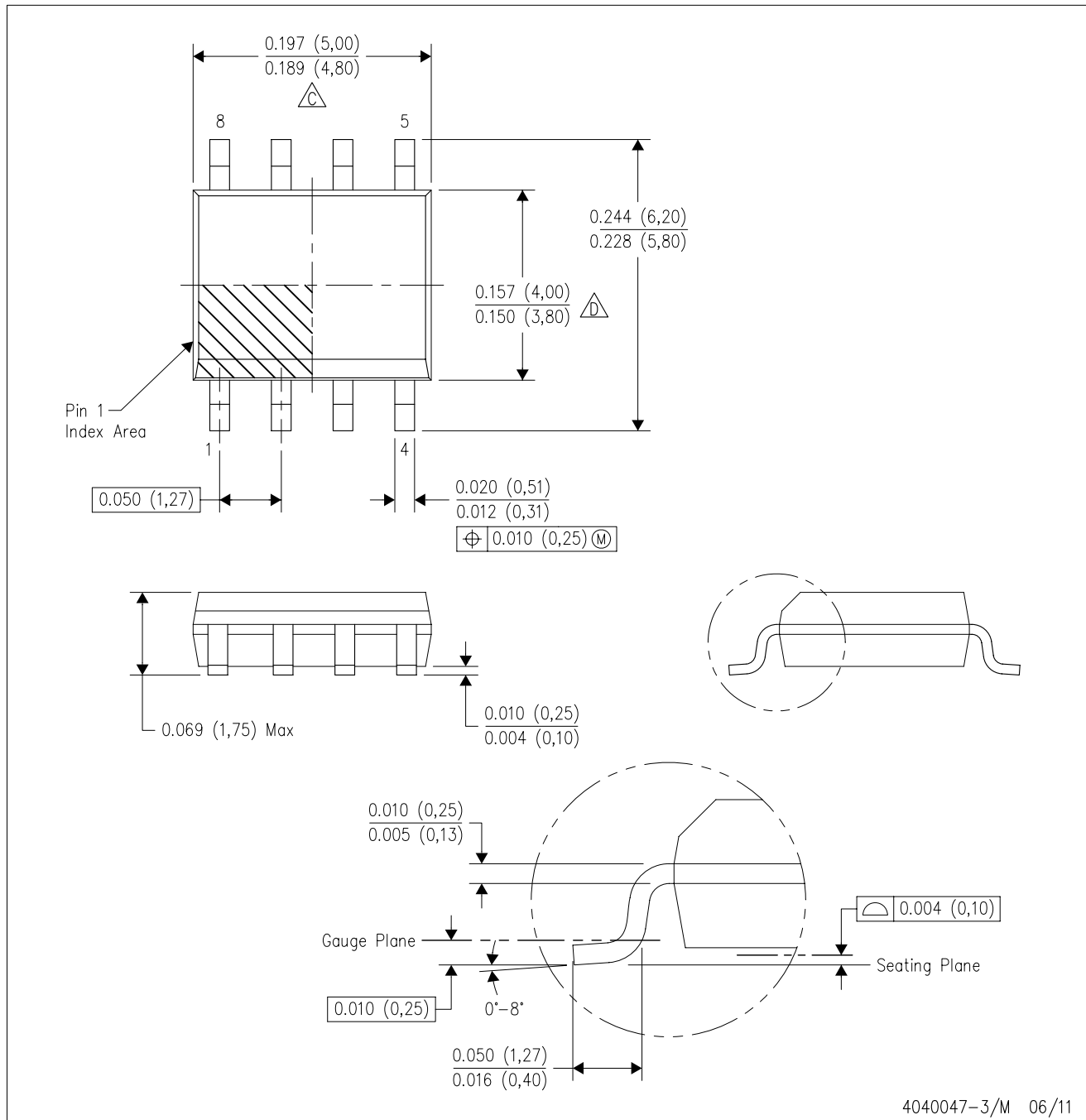

IMPORTANT NOTICE

Texas Instruments Incorporated (TI) reserves the right to make corrections, enhancements, improvements and other changes to its semiconductor products and services per JESD46, latest issue, and to discontinue any product or service per JESD48, latest issue. Buyers should obtain the latest relevant information before placing orders and should verify that such information is current and complete.

TI's published terms of sale for semiconductor products (<http://www.ti.com/sc/docs/stdterms.htm>) apply to the sale of packaged integrated circuit products that TI has qualified and released to market. Additional terms may apply to the use or sale of other types of TI products and services.

Reproduction of significant portions of TI information in TI data sheets is permissible only if reproduction is without alteration and is accompanied by all associated warranties, conditions, limitations, and notices. TI is not responsible or liable for such reproduced documentation. Information of third parties may be subject to additional restrictions. Resale of TI products or services with statements different from or beyond the parameters stated by TI for that product or service voids all express and any implied warranties for the associated TI product or service and is an unfair and deceptive business practice. TI is not responsible or liable for any such statements.

Buyers and others who are developing systems that incorporate TI products (collectively, "Designers") understand and agree that Designers remain responsible for using their independent analysis, evaluation and judgment in designing their applications and that Designers have full and exclusive responsibility to assure the safety of Designers' applications and compliance of their applications (and of all TI products used in or for Designers' applications) with all applicable regulations, laws and other applicable requirements. Designer represents that, with respect to their applications, Designer has all the necessary expertise to create and implement safeguards that (1) anticipate dangerous consequences of failures, (2) monitor failures and their consequences, and (3) lessen the likelihood of failures that might cause harm and take appropriate actions. Designer agrees that prior to using or distributing any applications that include TI products, Designer will thoroughly test such applications and the functionality of such TI products as used in such applications.

TI's provision of technical, application or other design advice, quality characterization, reliability data or other services or information, including, but not limited to, reference designs and materials relating to evaluation modules, (collectively, "TI Resources") are intended to assist designers who are developing applications that incorporate TI products; by downloading, accessing or using TI Resources in any way, Designer (individually or, if Designer is acting on behalf of a company, Designer's company) agrees to use any particular TI Resource solely for this purpose and subject to the terms of this Notice.

TI's provision of TI Resources does not expand or otherwise alter TI's applicable published warranties or warranty disclaimers for TI products, and no additional obligations or liabilities arise from TI providing such TI Resources. TI reserves the right to make corrections, enhancements, improvements and other changes to its TI Resources. TI has not conducted any testing other than that specifically described in the published documentation for a particular TI Resource.

Designer is authorized to use, copy and modify any individual TI Resource only in connection with the development of applications that include the TI product(s) identified in such TI Resource. NO OTHER LICENSE, EXPRESS OR IMPLIED, BY ESTOPPEL OR OTHERWISE TO ANY OTHER TI INTELLECTUAL PROPERTY RIGHT, AND NO LICENSE TO ANY TECHNOLOGY OR INTELLECTUAL PROPERTY RIGHT OF TI OR ANY THIRD PARTY IS GRANTED HEREIN, including but not limited to any patent right, copyright, mask work right, or other intellectual property right relating to any combination, machine, or process in which TI products or services are used. Information regarding or referencing third-party products or services does not constitute a license to use such products or services, or a warranty or endorsement thereof. Use of TI Resources may require a license from a third party under the patents or other intellectual property of the third party, or a license from TI under the patents or other intellectual property of TI.

TI RESOURCES ARE PROVIDED "AS IS" AND WITH ALL FAULTS. TI DISCLAIMS ALL OTHER WARRANTIES OR REPRESENTATIONS, EXPRESS OR IMPLIED, REGARDING RESOURCES OR USE THEREOF, INCLUDING BUT NOT LIMITED TO ACCURACY OR COMPLETENESS, TITLE, ANY EPIDEMIC FAILURE WARRANTY AND ANY IMPLIED WARRANTIES OF MERCHANTABILITY, FITNESS FOR A PARTICULAR PURPOSE, AND NON-INFRINGEMENT OF ANY THIRD PARTY INTELLECTUAL PROPERTY RIGHTS. TI SHALL NOT BE LIABLE FOR AND SHALL NOT DEFEND OR INDEMNIFY DESIGNER AGAINST ANY CLAIM, INCLUDING BUT NOT LIMITED TO ANY INFRINGEMENT CLAIM THAT RELATES TO OR IS BASED ON ANY COMBINATION OF PRODUCTS EVEN IF DESCRIBED IN TI RESOURCES OR OTHERWISE. IN NO EVENT SHALL TI BE LIABLE FOR ANY ACTUAL, DIRECT, SPECIAL, COLLATERAL, INDIRECT, PUNITIVE, INCIDENTAL, CONSEQUENTIAL OR EXEMPLARY DAMAGES IN CONNECTION WITH OR ARISING OUT OF TI RESOURCES OR USE THEREOF, AND REGARDLESS OF WHETHER TI HAS BEEN ADVISED OF THE POSSIBILITY OF SUCH DAMAGES.

Unless TI has explicitly designated an individual product as meeting the requirements of a particular industry standard (e.g., ISO/TS 16949 and ISO 26262), TI is not responsible for any failure to meet such industry standard requirements.

Where TI specifically promotes products as facilitating functional safety or as compliant with industry functional safety standards, such products are intended to help enable customers to design and create their own applications that meet applicable functional safety standards and requirements. Using products in an application does not by itself establish any safety features in the application. Designers must ensure compliance with safety-related requirements and standards applicable to their applications. Designer may not use any TI products in life-critical medical equipment unless authorized officers of the parties have executed a special contract specifically governing such use. Life-critical medical equipment is medical equipment where failure of such equipment would cause serious bodily injury or death (e.g., life support, pacemakers, defibrillators, heart pumps, neurostimulators, and implantables). Such equipment includes, without limitation, all medical devices identified by the U.S. Food and Drug Administration as Class III devices and equivalent classifications outside the U.S.

TI may expressly designate certain products as completing a particular qualification (e.g., Q100, Military Grade, or Enhanced Product). Designers agree that it has the necessary expertise to select the product with the appropriate qualification designation for their applications and that proper product selection is at Designers' own risk. Designers are solely responsible for compliance with all legal and regulatory requirements in connection with such selection.

Designer will fully indemnify TI and its representatives against any damages, costs, losses, and/or liabilities arising out of Designer's non-compliance with the terms and provisions of this Notice.