

UCC3956 Switch Mode Lithium-Ion Battery Charger Controller, Evaluation Board, Schematic, and List of Materials

By Eddy Wells

The UCC3956 Evaluation Kit allows the design engineer to evaluate the operation and performance of the Lithium-Ion Battery Charger Controller. The controller is designed to implement a DC to DC buck converter and features a four state charge control algorithm that enables the charger to safely and rapidly restore the battery pack to

full capacity. The evaluation board is initially configured to charge a 2-Cell 1200mA Hour battery pack, however, the board can be modified to address a variety of applications. The UCC3956 Data Sheet contains detailed information about the use of the controller.

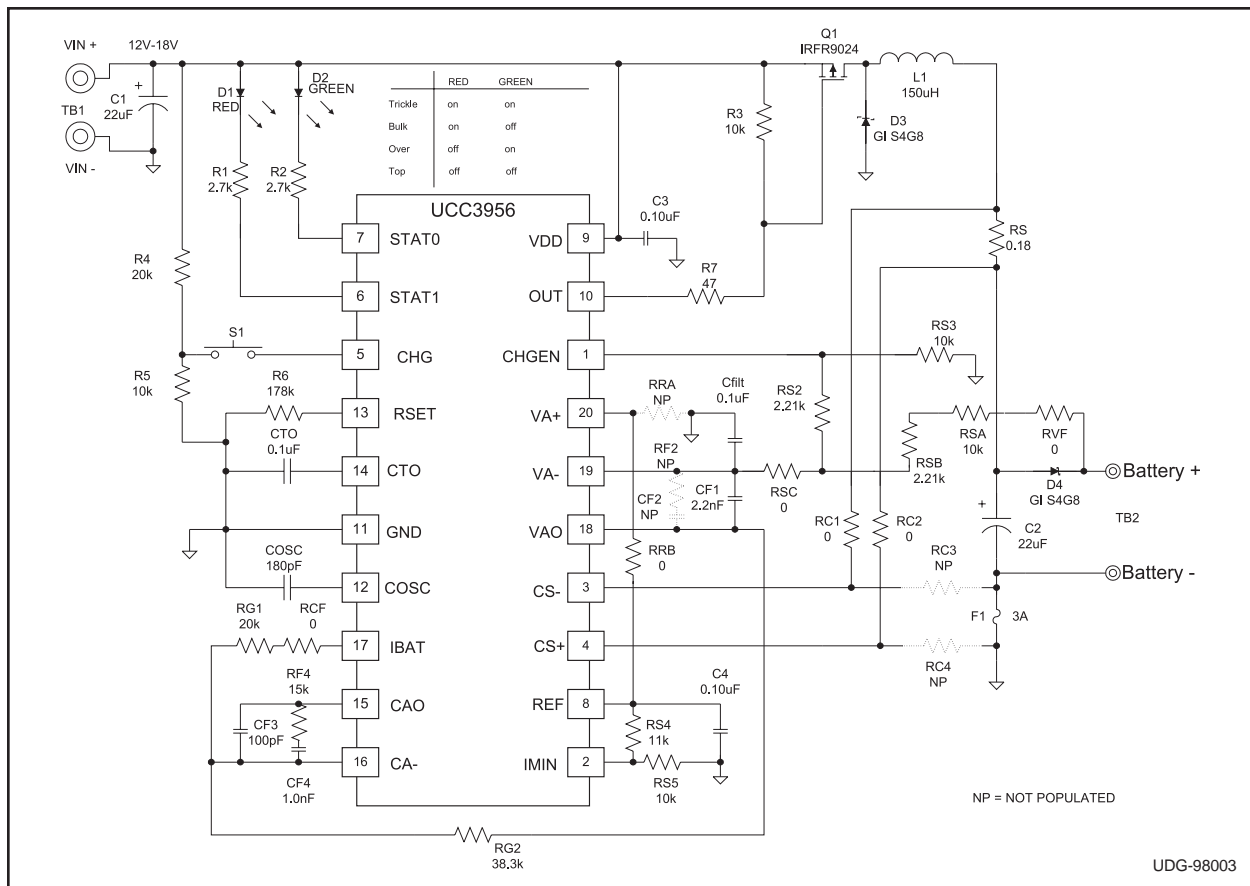

Figure 1. Evaluation Board Schematic

Buck Power Stage

The evaluation board charger schematic is shown in Figure 1. Although the IC will operate with a VDD between 7 and 18 volts, the two cell design will require at least 12 volts to be able to charge the pack to 8.20 volts. To ensure low noise on the board, 22µF Tantalum capacitors (C1,C2) are added to the input and output terminals, while de-

coupling capacitors (C3, C4) are placed on the controller's reference and VDD. The PWM buck power stage consists of L1, Q1, and D3. The charger is designed to deliver 1.2 amps of bulk current (1C charge rate) and L1 is sized to provide continuous current with 25% ripple. A 3 amp fuse (F1) prevents destructive current from being applied to the battery in the event of a fault, while diode D4 blocks reverse battery current.

Current Sense Circuitry

Inductor current is sensed across RS with a differential amplifier at the CS+ and CS– pins (notice current flows from CS– to CS+). The evaluation board has been configured with a “high side” current sense resistor, which has a DC operating voltage a diode drop above the positive terminal of the pack. This configuration allows the negative terminal of the pack to be referenced to circuit ground. High side current sensing is selected by populating RC1 and RC2 with zero ohm jumpers and by not populating (NP) RC3 and RC4. Certain applications may require a low side current sense solution. Examples include designs where the battery voltage exceeds the controller’s VDD rating, or where a high side sense resistor would have excessive common mode noise. Low side current sensing can be implemented by swapping F1 and RS. In this case, RC3 and RC4 would have zero ohm jumpers, while RC1 and RC2 would not be populated.

Feedback Components

The feedback design of the 2 cell charger is presented in the application section of the data sheet and will not be repeated here. Resistors RCF and RVF are initially populated with zero ohm jumpers and are assumed to be zero ohms in the equations that follow. In the evaluation of the charger’s control loops, these jumpers can be replaced with low value resistors (50 ohm) to facilitate the use of a network analyzer. The current amplifier network for the two cell design consists of a pole-zero-pole response provided by CF3, CF4, and RF4, resulting in a crossover frequency around 10kHz. The voltage amplifier network consists of a single pole response, provided by CF1, with a crossover frequency of 2kHz. Components CF2 and RF2 are not populated, but allow the voltage feedback network to be modified.

Oscillator Frequency

The PWM frequency is determined by Equation 1. A 180pF COSC and a 178k RSET yield a switching frequency of 100kHz.

$$Frequency = \frac{3.475}{(COSC + 20pF) \cdot RSET} \quad (1)$$

Charge State Logic

A charge cycle is initiated by pressing the momentary push button switch S1. Resistors R4 and R5 keep the CHG pin voltage between 3 and 6 volts when S1 is closed. The controller has two status

output pins, STAT0 and STAT1, which drive LEDs to indicate the states of the charger. An LED decode chart is printed on the evaluation board.

- **TR:** The trickle state is indicated when a reduced current is being delivered by the charger because the pack voltage is depleted below the trickle threshold. This state will also be indicated when power is initially applied to the board before a charge cycle is initiated.
- **BLK:** The constant current or bulk state is indicated when bulk current is being delivered by the charger and the pack voltage is between the trickle and the over-charge thresholds.
- **OVER:** The constant voltage or over-charge state is indicated when the pack voltage reaches 95% of its final value and the over-charge timer is initiated. Bulk current will continue being applied by the charger until the pack voltage reaches 100% of its final voltage, at which time the charge current will begin to decrease.
- **TOP:** The top-off state is indicated when the battery is at its final voltage and its current is below the top-off threshold set at the IMIN pin. The top-off indication notifies the user that the pack is near full capacity (maybe 95%) and is ready to be used. If the battery is not pulled from the charger, it will continue charging until the over-charge timer expires. When the over-charge timer expires, the LEDs will indicate the top-off state until a new charge cycle is initiated or power is cycled on the board.

Programming the Trickle State

The charger transitions from the trickle to bulk charge state when the CHGEN pin equals 2.05 volts. The corresponding pack voltage is given in equation 2. With RSA = RS3 = 10.0K and RSB = RS2 = 2.21K, the charger will remain in the trickle state with a pack voltage less than 5.0 volts.

$$V_{PACK_TRICKLE} = \left(\frac{RSA + RSB + RS2 + RS3}{RS3} \right) \cdot 2.05 \quad (2)$$

The programmed level of the trickle current is expressed in Equation 3. A trickle current of 60mA (C/20) is programmed with RG1=20K, RSET=178K and RS=0.18 ohm.

$$I_{TRICKLE} = \frac{RG1}{10 \cdot RSET \cdot RS} \quad (3)$$

Programming Bulk Current

Bulk current is set by the resistor values at the input to the current error amplifier and the current sense resistor as expressed in Equation 4. A bulk current of 1.2A is programmed with $R_{G1}=20K$, $R_{G2}=38.3K$ and $R_S=0.18$ ohm.

$$I_{BULK} = \frac{2.05 \cdot R_{G1}}{5 \cdot R_{G2} \cdot R_S} \quad (4)$$

Programming the Over Charge State

The controller indicates the over charge state and timer is initiated when the battery is at 95% of its final voltage (7.80V in this case). The over charge time period is programmed with CTO expressed in equation 5 (minutes). A capacitance of 0.1uF results in a period of 80 minutes. A capacitor in the pF range can be used when evaluating the timer's functionality (i.e. a 220pF CTO will give a 10 second time-out period).

$$TIMEOUT = 4550 \cdot CTO \cdot RSET \quad (5)$$

The charger will transition from a constant current to a constant voltage mode of operation when the voltage amplifier comes into regulation. This occurs when the voltage at the inverting input ($VA-$) of the amplifier reaches the value set at the non-inverting input ($VA+$). The voltage at $VA+$ is set by resistors R_{RA} and R_{RB} as expressed in equation 6. In the case of the 2 cell charger, R_{RA} is not populated and R_{RB} is a zero ohm jumper, yielding a $VA+$ voltage equal to the 4.1V reference.

$$V_+ = 4.1 \cdot \left(\frac{R_{RA}}{R_{RA} + R_{RB}} \right) \quad (6)$$

The final pack voltage is programmed by a resistor divider tied to the $VA-$ input (the resistor values are also used to set the trickle threshold). Equation 7 gives the formula for the final pack voltage. Capacitor C_{filt} is connected to the $VA-$ input to suppress a voltage spike that occurs when the charger transitions from the trickle to bulk state, preventing the overcharge timer from being initiated prematurely. A final voltage of 8.2V is achieved by using the resistor values of Figure 1.

$$V_{PACK_FINAL} = \left(\frac{R_{SA} + R_{SB} + R_{S2} + R_{S3}}{R_{S2} + R_{S3}} \right) \cdot V_+ \quad (7)$$

Programming the Top-off Current Level

The top-off state is indicated when the pack has reached its final voltage and the current to the pack has been reduced below the level set by equation 8. With $R_{S4}=11k$, $R_{S3}=10k$, and $R_S=0.18$ ohms, a current level of 120mA (C/10) will turn both LEDs off, indicating the battery is near full charge. Again, if the user does not pull the battery from the charger, it will continue to charge until the timer expires, restoring 100% capacity.

$$I_{TOP_OFF} = \frac{2.05 \cdot \left(1 - 2 \left[\frac{R_{S5}}{R_{S4} + R_{S5}} \right] \right)}{5 \cdot R_S} \quad (8)$$

Configuring the Charger to Address Different Pack Voltages

A single cell design requires a final pack voltage of 4.1 volts. This can be accomplished with two different approaches. The first approach is to leave $VA+$ connected to the 4.1V reference and replace R_{SA} and R_{SB} with zero ohm jumpers. An impedance, required for the voltage amplifier network, is provided by populating R_{SC} with a 10K resistor. Resistor values for R_{S2} and R_{S3} would need to be changed to set the trickle threshold. The second approach is to maintain the two-cell design values for R_{SA} , R_{SB} and R_{SC} , and to place equal value resistors at R_{RA} and R_{RB} , setting $VA+$ to 2.05 volts.

Three and four cell designs will require a higher value for $R_{SA}+R_{SB}$. Since a four cell design will have a final pack voltage of 16.8V, the input voltage of the charger may exceed the maximum rating of the controller. In this case, a level shifting circuit will be needed to drive Q1 and a Zener regulator will be needed at VDD.

For more complete information, pin descriptions and specifications for the UCC3956, please refer to the datasheet or contact your Unitrode Field Applications Engineer.

Reference Designator	Part Description	Distributor or Manufacturer Part Number
C1, C2	22 μ F Tantalum SMD-7343	Allied 213-6137
C3, C4, CFILT, CTO	0.1 μ F Ceramic SMD-1206	Digikey PCC104BCT-ND
CF1	2200pF Ceramic SMD-1206	Digikey PCC222BCT-ND
CF3	100pF Ceramic SMD-1206	Digikey PCC101CCT-ND
CF4	1000pF Ceramic SMD-1206	Digikey PCC102BCT-ND
COSC	180pF Ceramic SMD-0805	Digikey PCC181CGCT-ND
D1	Red LED	Digikey HLMP-1700QT-ND
D2	Green LED	Digikey HLMP-1790QT-ND
D3, D4	3A Schottky Diode SMD	General Instruments SS34
F1	3A Slow Blow Fuse SMD-7343	Digikey FF1169CT-ND
L1 (provided)	150 μ H Inductor, 1.5A	Coilcraft DO-5022P-154
(Alternate for lower current)	150 μ H Inductor, 1.0A	Coilcraft DO-3316P-154
(Alternate for low noise)	150 μ H Toroidal Inductor, 1.7A	Pulse Engineering (619)674-8100 PE-25645
Q1 (provided)	P-channel 0.28 RdSON SMD	International Rect. IRFR9024
(Alternate thru hole)	P-channel 0.28 Rdson TO-220	International Rect. IRF9Z24
R1,R2	2.67k Resistor SMD-1206	Digikey P2.76KFCT-ND
R3, R5, RSA, RS3, RS5	10.0k Resistor SMD-1206	Digikey P10.0KFCT-ND
R4, RG1	20.0k Resistor SMD-1206	Digikey P20.0KFCT-ND
R6	178k Resistor SMD-1206	Digikey P178KFCT-ND
R7	47 Ω Resistor SMD-1206	Digikey P47FCT-ND
RCF, RVF, RRB, RSC, RC1, RC2	0 Ω Jumper SMD-1206	Mouser 71-CRCW1206-0
RF4	15.0k Resistor SMD-1206	Digikey P15.0KFCT-ND
RG2	38.3k Resistor SMD-1206	Digikey P38.3KFCT-ND
RS2, RSB	2.21k Resistor SMD-1206	Digikey P2.21KFCT-ND
RS	0.18 Ω Resistor SMD-2512	Digikey P.18VCT-ND
RS4	11.0k Resistor SMD-1206	Digikey P11.0KFCT-ND
S1	Momentary Push Switch	Digikey CKN9002CT-ND
TB1, TB2	Terminal Blocks	Digikey ED1601-ND
U1	Charger Controller	Unitrode UCC3965 SOIC-20
CF2, RC3, RC4, RRA, RF2	Not populated	

Table 1. Parts list for the 2 Cell Charger in Figure 1.

IMPORTANT NOTICE

Texas Instruments and its subsidiaries (TI) reserve the right to make changes to their products or to discontinue any product or service without notice, and advise customers to obtain the latest version of relevant information to verify, before placing orders, that information being relied on is current and complete. All products are sold subject to the terms and conditions of sale supplied at the time of order acknowledgement, including those pertaining to warranty, patent infringement, and limitation of liability.

TI warrants performance of its semiconductor products to the specifications applicable at the time of sale in accordance with TI's standard warranty. Testing and other quality control techniques are utilized to the extent TI deems necessary to support this warranty. Specific testing of all parameters of each device is not necessarily performed, except those mandated by government requirements.

CERTAIN APPLICATIONS USING SEMICONDUCTOR PRODUCTS MAY INVOLVE POTENTIAL RISKS OF DEATH, PERSONAL INJURY, OR SEVERE PROPERTY OR ENVIRONMENTAL DAMAGE ("CRITICAL APPLICATIONS"). TI SEMICONDUCTOR PRODUCTS ARE NOT DESIGNED, AUTHORIZED, OR WARRANTED TO BE SUITABLE FOR USE IN LIFE-SUPPORT DEVICES OR SYSTEMS OR OTHER CRITICAL APPLICATIONS. INCLUSION OF TI PRODUCTS IN SUCH APPLICATIONS IS UNDERSTOOD TO BE FULLY AT THE CUSTOMER'S RISK.

In order to minimize risks associated with the customer's applications, adequate design and operating safeguards must be provided by the customer to minimize inherent or procedural hazards.

TI assumes no liability for applications assistance or customer product design. TI does not warrant or represent that any license, either express or implied, is granted under any patent right, copyright, mask work right, or other intellectual property right of TI covering or relating to any combination, machine, or process in which such semiconductor products or services might be or are used. TI's publication of information regarding any third party's products or services does not constitute TI's approval, warranty or endorsement thereof.