

# ***Simplified Solutions for Hot Swap Power Management in Telecom Systems***

---

## **Contents**

<b>1</b>	<b>Introduction</b> .....	<b>2</b>
<b>2</b>	<b>Hot Swap Power Manager Circuit</b> .....	<b>2</b>
<b>3</b>	<b>Theory of Operation</b> .....	<b>3</b>
<b>4</b>	<b>Completing the Hot Swap Circuit Design</b> .....	<b>6</b>
<b>5</b>	<b>References</b> .....	<b>7</b>

---

## **ABSTRACT**

Engineers designing plug-in or adapter cards for the –48-Vdc distribution environment often need an efficient, cost-effective means of implementing hot swap capability. Hot swap solutions vary in complexity, some adding features for system or operator control and interface or other related functions. However, it is ultimately the basic function of applying input power to the module's bulk capacitance that lays the foundation for effective and reliable hot swap performance. In addition, a preference or requirement for direct inrush slew-rate control is often weighed against the corresponding increases, both real and perceived, in design complexity, time, and effort.

This application note presents a simple hot swap solution for –48-Vdc systems built around an integrated control device from Texas Instruments. The circuit is easily adapted across a range of load characteristics by selecting the appropriate configuration values from the table provided. The resultant hot swap interface provides di/dt control, current limiting, circuit breaker function, and automatic turn-on, with a minimal number of components and design effort.

## 1 Introduction

Typical telecom and datacom systems often distribute power throughout the component racks and chassis at a  $-48\text{-Vdc}$  potential. Subsystem modules within the racks subsequently convert  $-48\text{-V}$  power to the local regulation level(s) needed by the module electronics. This scheme emerged early on in the communications industry as the standard for power distribution in these types of systems, as it offers numerous benefits.

When the individual plug-in modules of these racks require hot swap capability, solution complexity can vary across a wide range with system requirements. Hot swap is the ability to safely insert a board, module or cable into, or remove it from, a host system without first interrupting power to the system, and without disturbing operations or transactions occurring within the system. Both hardware and software features have been used to achieve this capability and to control the extent of connection automation. Examples of hardware features include remote-enable inputs, fault reporting (both of these either level-shifted or isolated), start-up delay, undervoltage and overvoltage protection, and supply sequencing. However, at the basis of any of these solutions is the ability to safely control the application of  $-48\text{-Vdc}$  power to the load electronics.

This application note presents a simplified solution which performs only the most basic functions of hot swap. This eliminates additional components for situations where the added cost and complexity is not warranted. Some of the features provided in this implementation are:

- inrush current control (soft-start)
- maximum current limiting
- electronic circuit-breaker function
- automatic fault retry

## 2 Hot Swap Power Manager Circuit

The hot-swap power manager circuit shown in Figure 1 illustrates the overall configuration and component connections, and defines some fixed component values. These fixed values apply over a wide range of input supply and load characteristics. However, some of the components are shown with a flag note only and are used to set the operating parameters for the U1 device, tailoring the circuit to the application's specific requirements. To reduce design time and effort, a range of typical application parameters has been compiled into a matrix, with the appropriate programming values listed for each matrix entry. The matrix is shown in Table 1. Users can select the load characteristics most closely resembling their target system, or interpolate between table entries as required.

The solution requires a minimum number of components. It uses an 8-pin controller with an external sense resistor and power MOSFET for current sense and switching. These three devices are supported by a total of seven small passives and one small-signal MOSFET.

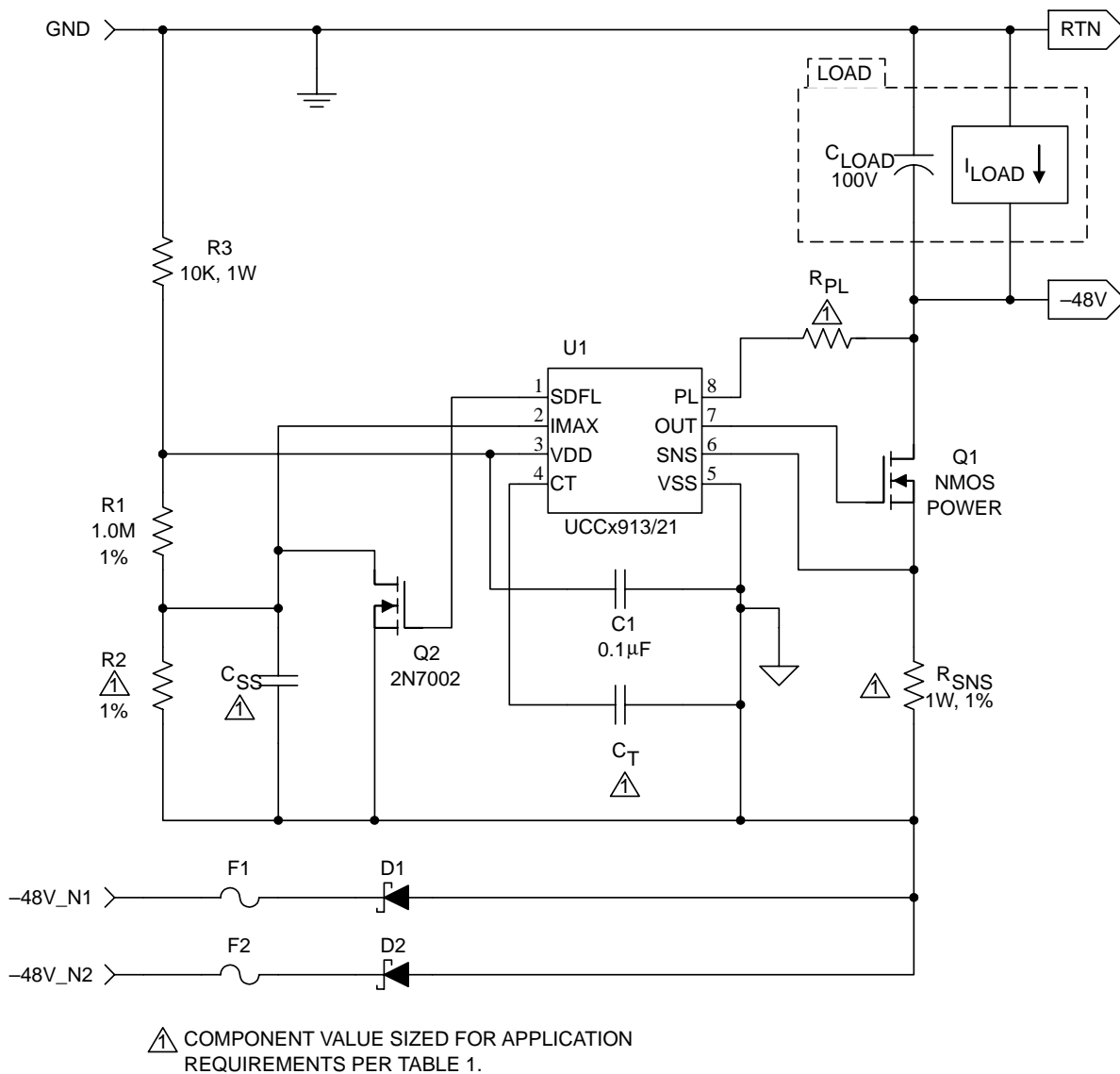

**Figure 1. Hot Swap Power Manager Circuit for -48 Vdc (Telecom) Applications**

### 3 Theory of Operation

A number of integrated hot swap controllers are currently available for -48-Vdc distribution systems. Texas Instruments (TI) currently offers two families of such devices, the UCCx913 and UCCx921 Negative Voltage Hot Swap Power Manager (HSPM) devices. Options within each family cover the commercial and industrial temperature ranges. The two device types are extremely similar; both provide the same basic functions of hot swap control, circuit breaker and also remote enable and a fault output in an 8-pin SOIC. The UCCx921 type also offers user selection between latched and retry modes of operation during a fault, whereas the UCCx913 provides retry mode only. In addition, the UCCx921 is specified with tighter tolerances on its internal shunt regulator. As used in this solution, the tighter tolerance is helpful in providing tighter control of the current limit range.

The devices function by sensing current to the load as a voltage drop across an external low-value resistor ( $R_{SNS}$  in the Figure 1 schematic). The current magnitude information is compared to an internally generated fault threshold, and to a user-programmable current limit threshold. The results of these comparisons determine the status of the gate drive for the external MOSFET. An internal timer, programmable with an external capacitor ( $C_T$ ), is used to filter out nuisance trips, and establish a time limit for high-current charging of the load capacitance after PCB insertion.

During an insertion event, once the input supply to the controller device has reached the UVLO threshold, the internal gate drive circuitry is enabled to turn on the external MOSFET. Once the MOSFET's  $V_{GS(on)}$  threshold is exceeded, current begins to flow to the load, charging input bulk capacitance. Controlled ramping of the load current is achieved by using soft-start capacitor  $C_{SS}$ , as shown in Figure 1. Control circuitry within the device, called the linear current amplifier (LCA), forces the drop across  $R_{SNS}$  to track the voltage at the IMAX pin. The voltage across  $C_{SS}$  increases with an RC time constant and consequently, load current ramps with the same characteristic.

If, during start-up, the load current exceeds the fault level, an internal current source begins charging the  $C_T$  capacitor, starting the timer, but current ramping continues. If the current magnitude eventually reaches the maximum sourcing limit (the dc IMAX value), it is limited at that level for the remaining voltage ramp time. If the high-current condition terminates prior to expiration of the timer (i.e. the output charges to the input supply potential), the gate is driven high, fully enhancing the pass MOSFET. The hot-swap interface now presents a low impedance path between supply and load for normal, steady-state operation. If however, current demand above the fault level continues through expiration of the timer, the pass MOSFET is switched off. As configured in this solution, the fault condition is retried at a safe, predefined duty cycle.

This linear mode of operation makes the MOSFET appear as a controlled current source to the load. The result is a smooth current ramp to the load, without the inrush spikes that would otherwise be generated (see Figure 2). The inrush control also results in a smooth voltage ramp to the module, with minimal drops and glitches on the backplane side of the insertion interface.

The fault threshold is internally fixed at a nominal 50 mV sense voltage. The fault current level can therefore be set for the adapter card by selecting the appropriate value of sense resistor. This is stated mathematically by equation (1).

$$R_{SNS} = \frac{V_{SNS}}{I_{FLT}} = \frac{50 \text{ mV}}{I_{FLT}} \quad (1)$$

where:

- $R_{SNS}$  = the sense resistor value, in milli-Ohms ( $m\Omega$ ), and
- $I_{FLT}$  = the nominal fault current level, in Amperes (A)

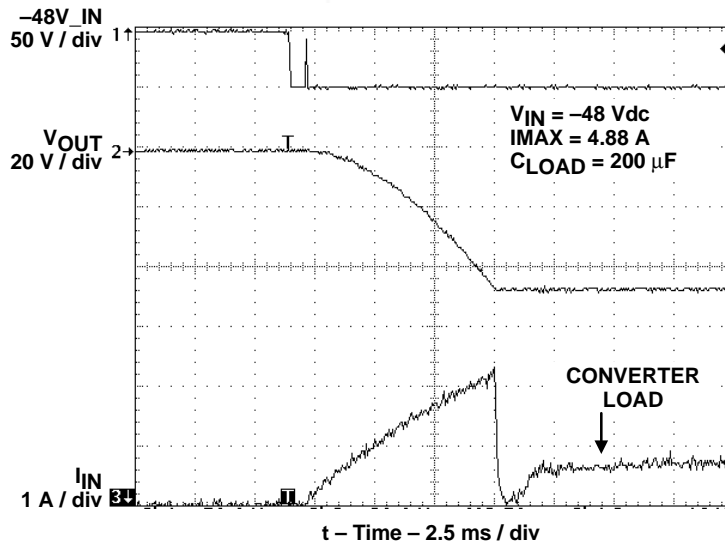

**Figure 2. Hot-Swap Start-Up Waveforms Showing Input Voltage and Current Ramps**

The maximum sourcing current limit is established by the voltage applied at the I<sub>MAX</sub> pin of the device, relative to V<sub>SS</sub>. In the current-limit mode described above, this current can be calculated from equation (2). To set this limit to a particular value, equation (2) is used to determine the required voltage at I<sub>MAX</sub>.

$$V_{I_{MAX}} = I_{MAX} \times R_{SNS} \quad (2)$$

where:

- V<sub>I<sub>MAX</sub></sub> = the voltage applied at the I<sub>MAX</sub> pin,
- I<sub>MAX</sub> = the maximum current sourced to the load, and
- R<sub>SNS</sub> = the sense resistor value

Typically, a resistor divider from the VDD pin is used to establish the V<sub>I<sub>MAX</sub></sub> setting. This is shown as R1 and R2 in Figure 1.

The UCCx913 and UCCx921 devices employ a floating topology to allow use in systems with supply potentials more negative than -10.5 Vdc. The controllers are referred to the negative input rail, and as such, VDD potential can *float* relative to the system ground node. To accomplish this, these devices incorporate an on-chip shunt regulator providing a nominal 9.5 V for device supply and MOSFET gate drive. The regulator is current-fed via an external resistor (R3), sized appropriately for the anticipated input supply range. Application circuits should provide a minimum 2.0 mA supply at the lowest supply potential.

As the power switch between input supply and load, MOSFET Q1 conducts all the current demanded by the load. Therefore, one criteria for Q1 selection is the device's ability to dissipate sufficient power under full load conditions. During steady-state operation, this power dissipation is described by equation (3).

$$P_{D(Q1)} = (I_{LOAD})^2 \times R_{DS(on)} \quad (3)$$

where:

- $P_{D(Q1)}$  = power dissipated within the device
- $I_{LOAD}$  = load current magnitude
- $R_{DS(ON)}$  = the maximum on-resistance of the device, under the current gate-drive and junction temperature conditions

A less obvious consideration is protecting the MOSFET during load fault conditions. The circuit of Figure 1 periodically tests the load for a continued fault. In the case of a short circuit, the full input supply potential appears across Q1 each time it is turned on. Control circuitry in the HSPM device uses the  $C_T$  capacitor to control the timing of this retry mode, limiting Q1 on-times for a nominal duty cycle of 2.7% (3.7% maximum). For applications that require further duty cycle limiting, the  $R_{PL}$  resistor can be used, connected as shown. Current supplied via  $R_{PL}$  when the drop across the MOSFET is greater than 5 V, is used to charge the  $C_T$  capacitor faster, thus decreasing the time to reach the turn-off threshold. The Q1 duty cycle is thereby reduced accordingly.

For further details on the HSPM operation and complete specifications, please consult the device data sheets (see Section 5, *References*).

## 4 Completing the Hot Swap Circuit Design

As indicated in Section 2, *Hot Swap Power Management Circuit*, the recommended values for the configuration components are shown in Table 1, for an assortment of load characteristics.

The first two columns list typical values that may be encountered in a –48-Vdc distribution system. The *nominal load* values are the steady-state operating load on the backplane side of the interface. The values shown for  $C_{LOAD}$  represent the total input bulk capacitance presented to the supply by the plug-in card. For example, this may be input filter capacitance on downstream converters. The next two columns give recommended settings for the fault ( $I_{FAULT}$ ) and current limit ( $I_{MAX}$ ) thresholds of the HSPM. For each load combination, two different options for soft-start capacitor are given in the  $C_{SS}$  column. The resultant component values are listed for the two HSPM device types discussed.

LOAD ATTRIBUTES		RECOMMENDED SETTINGS		COMPONENT VALUES					
				RESISTORS			CAPACITORS	HSPM DEVICES	
NOMINAL LOAD	$C_{LOAD}$ ( $\mu$ F)	$I_{FAULT}$	$I_{MAX}$	$R_{SNS}$ (m $\Omega$ )	$R_2$ ( $\Omega$ )	$R_{PL}$ ( $\Omega$ )	$C_{SS}$ ( $\mu$ F)	UCCx913	UCCx921
								$C_T$ ( $\mu$ F)	
1 A	220	2 A	4 A	25	10.7k	270k	0.1	0.82	0.68
							1.0	0.68	0.68
	470						0.1	1.68	1.5
							1.0	1.68	1.5
2 A	220	3.33 A	6 A	15	9.53k	165k	0.047	0.82	0.68
							0.47	0.68	0.68
	470						0.047	1.82	1.56
							0.47	1.68	1.56
3 A	470	5 A	8 A	10	8.87k <sup>†</sup>	110k	0.047	1.76	–
							0.47	1.5	–
	680						0.047	2.7	–
							0.47	2.2	–
3 A	470	5 A	8 A	10	8.45k	130k	0.047	–	1.5
							0.47	–	1.2
	680						0.047	–	2.2
							0.47	–	2.0

<sup>†</sup> For the 3-A load case, the actual current limit ( $I_{MAX}$ ) threshold is 8.35 A for the UCCx913 type using the values shown.

To derive the component values in Table 1, certain system and board-level parameters must be defined. First, the input supply is assumed to be a nominal  $-48$  Vdc. However, the plug-in is expected to operate over an input range between  $-36$  Vdc to  $-72$  Vdc. The primary load at the hot-swap outputs is assumed to be a dc-to-dc converter or string of converters. These could be off-the-shelf quarter or half-brick type converters, or the user's custom discrete design. The converter is assumed to have its own undervoltage lockout (UVLO) function, with a minimum turn-on threshold (input rising) of  $31$  Vdc. Discrepancies between this value and the module's actual specifications do have an impact on circuit operation. However, the circuit can easily be compensated for any such differences. Generally, a lower load UVLO threshold may require a larger capacitor at  $C_T$ . The  $C_T$  values recommended here are conservative, and therefore should not require adjustment except for threshold decreases of several volts. In addition, the load is assumed to draw nominal current immediately after the supply exceeds the UVLO threshold. Any soft-start function, or inherent or intended startup delay, would help compensate for lower UVLO values.

The values listed in the *nominal load* column correspond to the steady-state operating load on the input supply with the supply voltage at  $-48$  Vdc. When the recommended fault and maximum current settings were established, variances in load current over the supply range were considered. To do this, the converter efficiency was assumed to be constant over the entire operating range. This is not usually true, although it is a reasonably close approximation for the commercially available integrated dc-to-dc converters (aka *bricks*).

For the suggested values of  $R_{P_L}$  given in Table 1, the resultant duty cycles in a fault retry mode range from approximately 0.54% for the 1-A load examples, decreasing to about 0.25% for the 3-A cases. When selecting a device to use for Q1, the designer should ensure a minimum dissipative capability of 2-W average power at the intended maximum operating ambient temperature.

For a more complete discussion of hot swap power management for the telecom environment, the reader is referred to Texas Instruments Literature No. SLUA250. This application report contains a step-by-step hot-swap design procedure, the details for calculating programming values, discussion of using plug-in modules for subsequent dc-to-dc conversion, and performance evaluation of an example design. All documents listed in Section 5, *References*, are available on the TI web site, <http://www.ti.com>.

## 5 References

UCCx913 Negative Voltage Hot Swap Power Manager, Data Sheet; Texas Instruments; Literature No. SLUS274; January 1999

UCCx921 Latchable Negative Floating Hot Swap Power Manager, Data Sheet; Texas Instruments; Literature No. SLUS207; March 1998

UCC3913 or UCC3921 Hot Swap Power Manager Evaluation Board, Application Report, Texas Instruments, Literature No. SLUU076, August 2000.

*A Power Management Interface Circuit for Telecom Hot Swap with Local DC/DC Conversion*, Application Report, Texas Instruments, Literature No. SLUA250, March 2001.

## IMPORTANT NOTICE

Texas Instruments and its subsidiaries (TI) reserve the right to make changes to their products or to discontinue any product or service without notice, and advise customers to obtain the latest version of relevant information to verify, before placing orders, that information being relied on is current and complete. All products are sold subject to the terms and conditions of sale supplied at the time of order acknowledgment, including those pertaining to warranty, patent infringement, and limitation of liability.

TI warrants performance of its products to the specifications applicable at the time of sale in accordance with TI's standard warranty. Testing and other quality control techniques are utilized to the extent TI deems necessary to support this warranty. Specific testing of all parameters of each device is not necessarily performed, except those mandated by government requirements.

Customers are responsible for their applications using TI components.

In order to minimize risks associated with the customer's applications, adequate design and operating safeguards must be provided by the customer to minimize inherent or procedural hazards.

TI assumes no liability for applications assistance or customer product design. TI does not warrant or represent that any license, either express or implied, is granted under any patent right, copyright, mask work right, or other intellectual property right of TI covering or relating to any combination, machine, or process in which such products or services might be or are used. TI's publication of information regarding any third party's products or services does not constitute TI's approval, license, warranty or endorsement thereof.

Reproduction of information in TI data books or data sheets is permissible only if reproduction is without alteration and is accompanied by all associated warranties, conditions, limitations and notices. Representation or reproduction of this information with alteration voids all warranties provided for an associated TI product or service, is an unfair and deceptive business practice, and TI is not responsible nor liable for any such use.

Resale of TI's products or services with statements different from or beyond the parameters stated by TI for that product or service voids all express and any implied warranties for the associated TI product or service, is an unfair and deceptive business practice, and TI is not responsible nor liable for any such use.

Also see: [Standard Terms and Conditions of Sale for Semiconductor Products](http://www.ti.com/sc/docs/stdterms.htm). [www.ti.com/sc/docs/stdterms.htm](http://www.ti.com/sc/docs/stdterms.htm)

### Mailing Address:

Texas Instruments  
Post Office Box 655303  
Dallas, Texas 75265