

- Integrated 0.15-Ω Power MOSFET
- 3-V to 8-V Operation
- Digital Programmable Current Limit from 0 A to 3 A
- Electronic Circuit Breaker Function
- 1μA I<sub>CC</sub> When Disabled
- Programmable On-Time
- Programmable Start Delay
- Fixed 3% Duty Cycle
- Unidirectional Switch
- Thermal Shutdown
- Fault-Output Indicator
- Maximum-Output Current Can Be Set to 1 A Above the Programmed Fault Level or to a Full 4 A
- Power SOIC, Low-Thermal Resistance Packaging

**description**

The UCC3912 family of hot swap power managers provides complete power management, hot swap capability, and circuit breaker functions. The only component required to operate the device, other than supply bypassing, is the fault timing capacitor, C<sub>T</sub>. All control and housekeeping functions are integrated, and externally programmable. These include the fault current level, maximum output-sourcing current, maximum fault time, and startup delay. In the event of a constant fault, the internal fixed 3% duty cycle ratio limits average output power.

The internal 4-bit DAC allows programming of the fault level current from 0 A to 3 A with 0.25-A resolution. The IMAX control pin sets the maximum sourcing current to 1 A above the fault level when driven low, and to a full 4 A when driven high for applications which require fast output capacitor charging.

When the output current is below the fault level, the output MOSFET is switched on with a nominal on resistance of 0.15 Ω. When the output current exceeds the fault level, but is less than the maximum sourcing level, the output remains switched on, but the fault timer starts charging C<sub>T</sub>. Once C<sub>T</sub> charges to a preset threshold, the switch is turned off, and remains off for 30 times the programmed fault time. When the output current reaches the maximum sourcing level, the MOSFET transitions from a switch to a constant current source. (continued)

**block diagram**

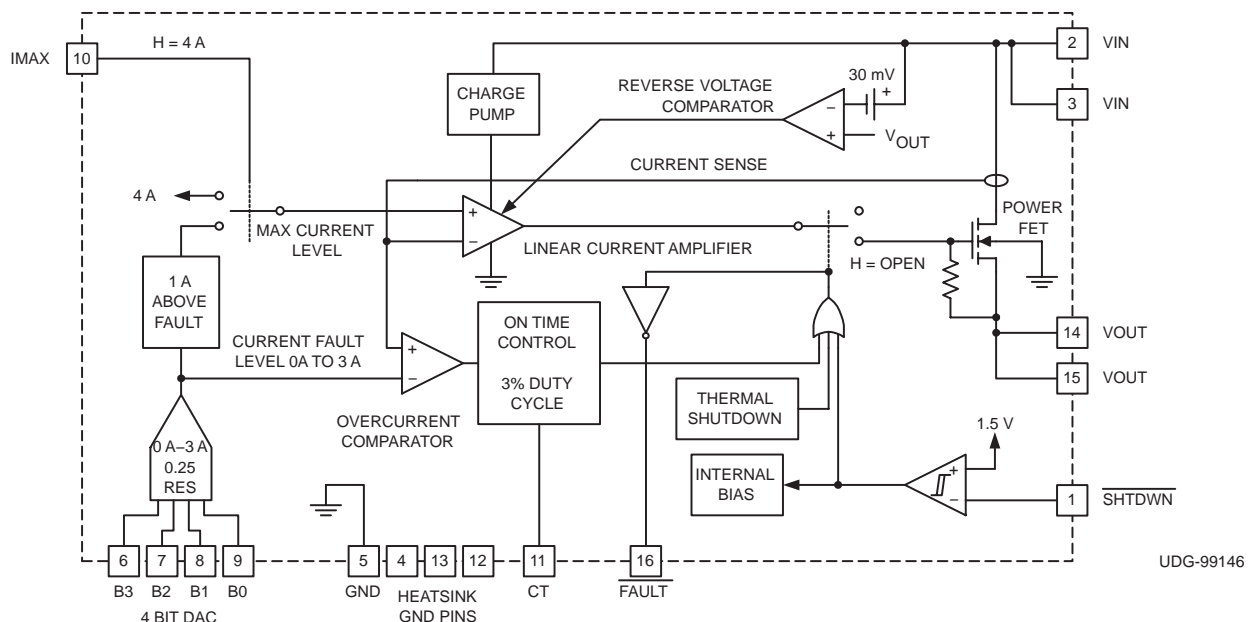

Please be aware that an important notice concerning availability, standard warranty, and use in critical applications of Texas Instruments semiconductor products and disclaimers thereto appears at the end of this data sheet.

PRODUCTION DATA information is current as of publication date. Products conform to specifications per the terms of Texas Instruments standard warranty. Production processing does not necessarily include testing of all parameters.

# UCC2912 UCC3912 PROGRAMMABLE HOT SWAP POWER MANAGER

SLUS241D – MARCH 1994 - REVISED NOVEMBER 2003

## description (continued)

The UCC3912 family is designed for unidirectional current flow, emulating an ideal diode in series with the power switch. This feature is particularly attractive in applications where many devices are powering a common bus, such as with SCSI Termpwr.

The UCC3912 family can be put into sleep mode drawing only 1- $\mu$ A of supply current. The  $\overline{\text{SHTDWN}}$  pin has a preset threshold hysteresis which allows the user the ability to set a time delay upon startup to achieve sequencing of power. Other features include an open drain  $\overline{\text{FAULT}}$  output indicator, thermal shutdown, under voltage lockout, and a low thermal resistance small outline package.

## absolute maximum ratings over operating free-air temperature (unless otherwise noted)<sup>†‡</sup>

VIN	8 V
$\overline{\text{FAULT}}$ sink current	50 mA
$\overline{\text{FAULT}}$ voltage	-0.3 to VIN
Output current	Self Limiting
Input voltage (B0, B1, B2, B3, IMAX, $\overline{\text{SHTDWN}}$ )	-0.3 to VIN
Storage temperature range, T <sub>stg</sub>	-65°C to 150°C
Operating junction temperature range, T <sub>J</sub>	-55°C to 150°C
Lead temperature (soldering, 10 sec.)	300°C

<sup>†</sup> Stresses beyond those listed under “absolute maximum ratings” may cause permanent damage to the device. These are stress ratings only, and functional operation of the device at these or any other conditions beyond those indicated under “recommended operating conditions” is not implied. Exposure to absolute-maximum-rated conditions for extended periods may affect device reliability.

<sup>‡</sup> Currents are positive into, negative out of the specified terminal. Consult Packaging Section of the Interface Products Data book (TI Literature Number SLUD002) for thermal limitations and considerations of packages.

## package information

**DIL-16, SOIC-16  
N, DP Package  
(TOP VIEW)**

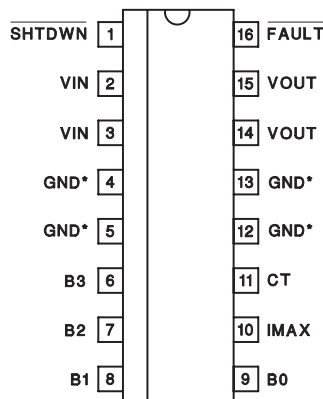

\*Pin 5 serves as lowest impedance to the electrical ground; Pins 4, 12, and 13 serve as heat sink/ground. These pins should be connected to large etch areas to help dissipate heat. For N package, pins 4, 12, and 13 are N/C.

**TSSOP-24,  
PWP Package  
(TOP VIEW)**

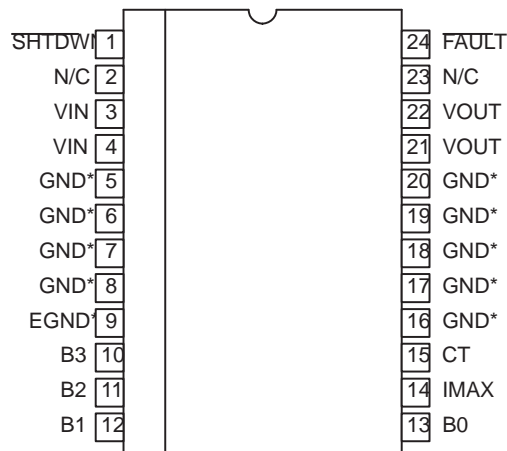

\*Pin 9 serves as lowest impedance to the electrical ground; other GND pins serve as heat sink/ground. These pins should be connected to large etch areas to help dissipate heat.

**PROGRAMMABLE HOT SWAP POWER MANAGER**

SLUS241D – MARCH 1994 - REVISED NOVEMBER 2003

electrical characteristics, these specifications apply for  $T_A = -40^{\circ}\text{C}$  to  $85^{\circ}\text{C}$  for the UCC2912;  $T_A = 0^{\circ}\text{C}$  to  $70^{\circ}\text{C}$  for the UCC3912,  $V_{IN} = 5\text{ V}$ ,  $I_{MAX} = 0.4\text{ V}$ ,  $SHTDWN = 2.4\text{ V}$  (unless otherwise stated)

**supply section**

PARAMETER	TEST CONDITIONS	MIN	TYP	MAX	UNITS
Voltage input range		3.0		8.0	V
Supply current			1.0	2.0	mA
Sleep mode current	$SHTDWN = 0.2\text{ V}$		0.5	5.0	$\mu\text{A}$

NOTE 1: All voltages are with respect to ground. Current is positive into and negative out of the specified terminal.

**output section**

PARAMETER	TEST CONDITIONS	MIN	TYP	MAX	UNITS
Voltage drop	$I_{OUT} = 1\text{ A}$		0.15	0.22	V
	$I_{OUT} = 2\text{ A}$		0.3	0.45	V
	$I_{OUT} = 3\text{ A}$		0.45	0.68	V
	$I_{OUT} = 1\text{ A}$ , $V_{IN} = 3\text{ V}$		0.17	0.27	V
	$I_{OUT} = 2\text{ A}$ , $V_{IN} = 3\text{ V}$		0.35	0.56	V
	$I_{OUT} = 3\text{ A}$ , $V_{IN} = 3\text{ V}$		0.5	0.8	V
Reverse leakage current	$V_{IN} < V_{OUT}$ , $SHTDWN = 0.2\text{ V}$ , $V_{OUT} = 5\text{ V}$		5	20	$\mu\text{A}$
Initial startup time	See Note 2		100		$\mu\text{s}$
Short circuit response	See Note 2		100		ns
Thermal shutdown	See Note 2		170		$^{\circ}\text{C}$
Thermal hysteresis	See Note 2		10		$^{\circ}\text{C}$

NOTE 1: All voltages are with respect to ground. Current is positive into and negative out of the specified terminal.

NOTE 2: Ensured by design. Not production tested.

**DAC section**

PARAMETER	TEST CONDITIONS	MIN	TYP	MAX	UNITS	
Output leakage	Code = 0000–0011		0	20	$\mu\text{A}$	
Trip current	Code = 0100	0.1	0.25	0.45	A	
	Code = 0101	0.25	0.50	0.75	A	
	Code = 0110	0.5	0.75	1.0	A	
	Code = 0111	0.75	1.00	1.25	A	
	Code = 1000	1.0	1.25	1.5	A	
	Code = 1001	1.25	1.50	1.75	A	
	Code = 1010	1.5	1.75	2.0	A	
	Code = 1011	1.7	2.00	2.3	A	
	Code = 1100	1.9	2.25	2.58	A	
	Code = 1101	2.1	2.50	2.9	A	
	Code = 1110	2.3	2.75	3.2	A	
	Code = 1111	2.5	3.0	3.5	A	
Maximum output current	Code = 0000 to 0011			0.02	mA	
Maximum output current over trip (current source mode)	UCC2912	Code = 0100 to 1111, $I_{MAX} = 0\text{ V}$	0.5	1.0	2.0	A
	UCC3912	Code = 0100 to 1111, $I_{MAX} = 0\text{ V}$	0.5	1.0	1.8	A
Maximum output current (current source mode)	Code = 0100 to 1111, $I_{MAX} = 2.4\text{ V}$	3.0	4.0	5.2	A	

NOTE 1: All voltages are with respect to ground. Current is positive into and negative out of the specified terminal.

# UCC2912 UCC3912 PROGRAMMABLE HOT SWAP POWER MANAGER

SLUS241D – MARCH 1994 - REVISED NOVEMBER 2003

electrical characteristics, these specifications apply for  $T_A = -40^{\circ}\text{C}$  to  $85^{\circ}\text{C}$  for the UCC2912;  $T_A = 0^{\circ}\text{C}$  to  $70^{\circ}\text{C}$  for the UCC3912,  $V_{IN} = 5\text{ V}$ ,  $I_{MAX} = 0.4\text{ V}$ ,  $SHTDWN = 2.4\text{ V}$  (unless otherwise stated)

## timer section

PARAMETER	TEST CONDITIONS	MIN	TYP	MAX	UNITS
CT charge current	$V_{CT} = 1.0\text{ V}$	-45.0	-36.0	-22.0	$\mu\text{A}$
CT discharge current	UCC2912 $V_{CT} = 1.0\text{ V}$	0.72	1.20	1.57	$\mu\text{A}$
	UCC3912 $V_{CT} = 1.0\text{ V}$	0.72	1.20	1.50	$\mu\text{A}$
Output duty cycle	$V_{OUT} = 0\text{ V}$	2.0	3.0	6.0	%
CT fault threshold		1.3	1.5	1.7	V
CT reset threshold		0.4	0.5	0.6	V

NOTE 1: All voltages are with respect to ground. Current is positive into and negative out of the specified terminal.

## shutdown section

PARAMETER	TEST CONDITIONS	MIN	TYP	MAX	UNITS
Shutdown threshold		1.1	1.5	1.9	V
Shutdown hysteresis			100		mV
Input current	$SHTDWN = 1\text{ V}$		100	500	nA

## fault output section

PARAMETER	TEST CONDITIONS	MIN	TYP	MAX	UNITS
Output leakage current				500	nA
Low level output voltage	$I_{OUT} = 10\text{ mA}$		0.4	0.8	V

## TTL input dc characteristics section

PARAMETER	TEST CONDITIONS	MIN	TYP	MAX	UNITS
TTL input voltage high	(can be connected to $V_{IN}$ )	2.0			V
TTL input voltage low				0.8	V
TTL input high current	$V_{IH} = 2.4\text{ V}$		3	10	$\mu\text{A}$
TTL input low current	$V_{IL} = 0.4\text{ V}$			1	$\mu\text{A}$

NOTE 1: All voltages are with respect to ground. Current is positive into and negative out of the specified terminal.

## pin description

**B0–B3:** These pins provide digital input to the DAC which sets the fault current threshold. They can be used to provide a digital soft-start, adaptive current limiting.

**CT:** A capacitor connected to ground sets the maximum fault time. The maximum fault time must be more than the time to charge the external capacitance in one cycle. The maximum fault time is defined as  $FAULT = 27.8 \times 10^3 \times CT$ . Once the fault time is reached the output will shutdown for a time given by:  $T_{SD} = 833 \times 10^3 \times CT$ , this equates to a 3% duty cycle.

**FAULT:** Open drain output which pulls low upon any condition which causes the output to open: fault, thermal shutdown, or shutdown.

**IMAX:** When this pin is set to logic low the maximum sourcing current will always be 1 A above the programmed fault level. When set to logic high, the maximum sourcing current will be a constant 4 A for applications which require fast charging of load capacitance.

**pin description (continued)**

**SHTDWN:** When this pin is brought to a logic low, the IC is put into a sleep mode drawing typically less than  $1 \mu\text{A}$  of  $I_{CC}$ . The input threshold is hysteretic, allowing the user to program a startup delay with an external RC circuit.

**VIN:** Input voltage to the UCC3912. The recommended voltage range is 3 V to 8 V. Both VIN pins should be connected together and to the power source.

**VOUT:** Output voltage from the UCC3912. When switched the output voltage will be approximately  $V_{IN} - (0.15 \Omega \times I_{OUT})$ . Both VOUT pins should be connected together and to the load.

**APPLICATION INFORMATION**

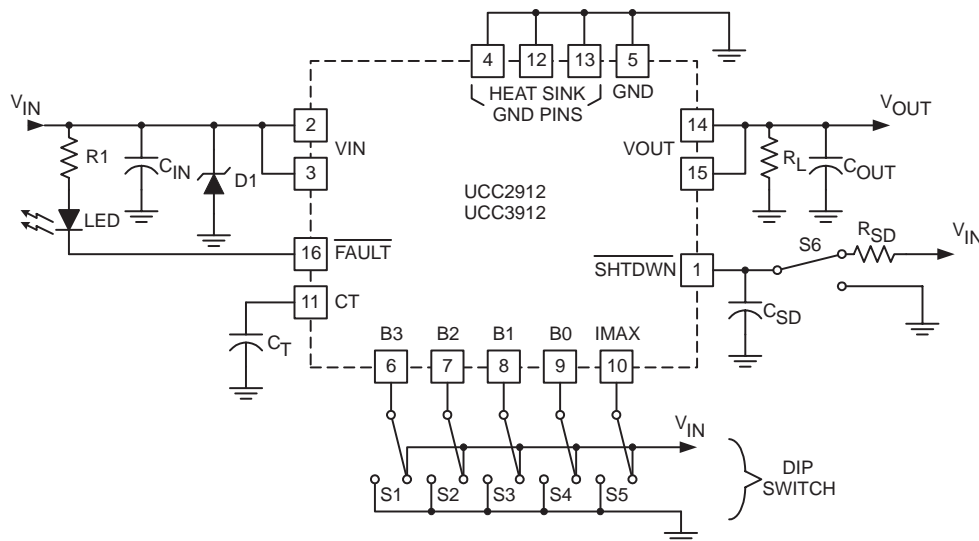

NOTE: For demonstration board schematic see Design Note DN-58 (TI Literature Number SLUA187).

UDG-99171

**Figure 1. Evaluation Circuit**

**protecting the UCC3912 from voltage transients**

The parasitic inductance associated with the power distribution can cause a voltage spike at  $V_{IN}$  if the load current is suddenly interrupted by the UCC3912. It is important to limit the peak of this spike to less than 8 V to prevent damage to the UCC3912. This voltage spike can be minimized by:

- Reducing the power distribution inductance (e.g., twist the positive and negative leads of the power supply feeding  $V_{IN}$ , locate the power supply close to the UCC3912, use a PCB ground plane,...etc.).
- Decoupling  $V_{IN}$  with a capacitor,  $C_{IN}$  (refer to Figure 1), located close to pins 2 and 3. This capacitor is typically less than  $1 \mu\text{F}$  to limit the inrush current.
- Clamping the voltage at  $V_{IN}$  below 8 V with a zener diode, D1 (refer to Figure 1), located close to pins 2 and 3.

**APPLICATION INFORMATION**

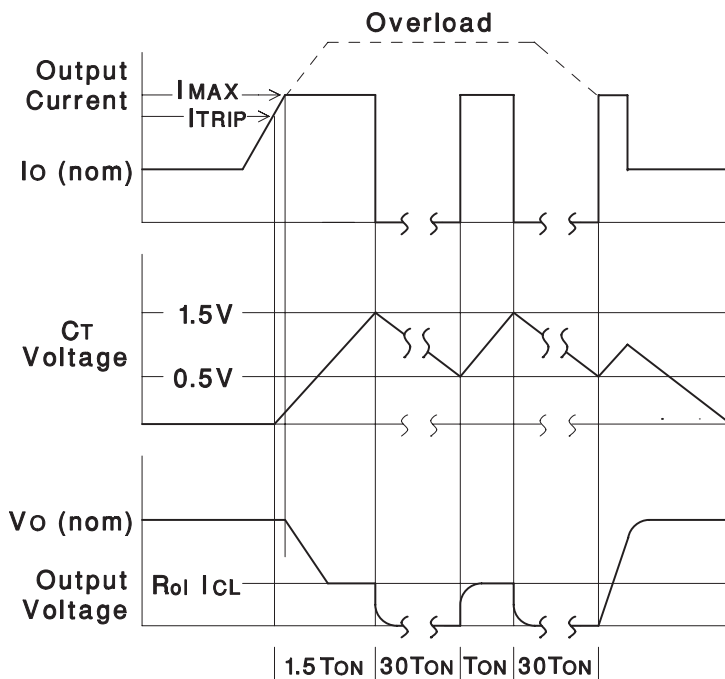

UDG-93019-4

**Figure 2. Load Current, Timing-Capacitor Voltage, and Output Voltage of the UCC3912 Under Fault Conditions.**

**estimating maximum load capacitance**

For hot-swap applications, the rate at which the total output capacitance can be charged depends on the maximum output current available and the nature of the load. For a constant-current current-limited controller, the output will come up if the load asks for less than the maximum available short-circuit current.

To ensure recovery of a duty-cycle from a short-circuited load condition, there is a maximum total output capacitance which can be charged for a given unit ON time (fault time). The design value of ON or fault time can be adjusted by changing the timing capacitor  $C_T$ .

For worst-case constant-current load of value just less than the trip limit;  $C_{OUT(max)}$  can be estimated from:

$$C_{OUT(max)} \approx (I_{MAX} - I_{LOAD}) \times \left( \frac{28 \times 10^3 \times C_T}{V_{OUT}} \right)$$

where  $V_{OUT}$  is the output voltage.

APPLICATION INFORMATION

For a resistive load of value  $R_L$ , the value of  $C_{OUT(max)}$  can be estimated from:

$$C_{OUT(max)} \approx \left[ \frac{28 \times 10^3 \times C_T}{R_L \times \ln \left[ \frac{1}{1 - \left( \frac{V_{OUT}}{I_{MAX} \times R_L} \right)} \right]} \right]$$

The overcurrent comparator senses both the DAC output and a representation of the output current. When the output current exceeds the programmed level the timing capacitor  $C_T$  charges with  $36 \mu A$  of current. If the fault occurs for the time it takes for  $C_T$  to charge up to 1.5 V, the fault latch is set and the output switch is opened. The output remains opened until  $C_T$  discharges to 0.5 V with a  $1.2\text{-}\mu A$  current source. Once the 0.5 V is reached the output is enabled and will either appear as a switch, if the fault is removed, or a current source if the fault remains. If the over current condition is still present, then  $C_T$  will begin charging, starting the cycle over, resulting in approximately a 3% on time.

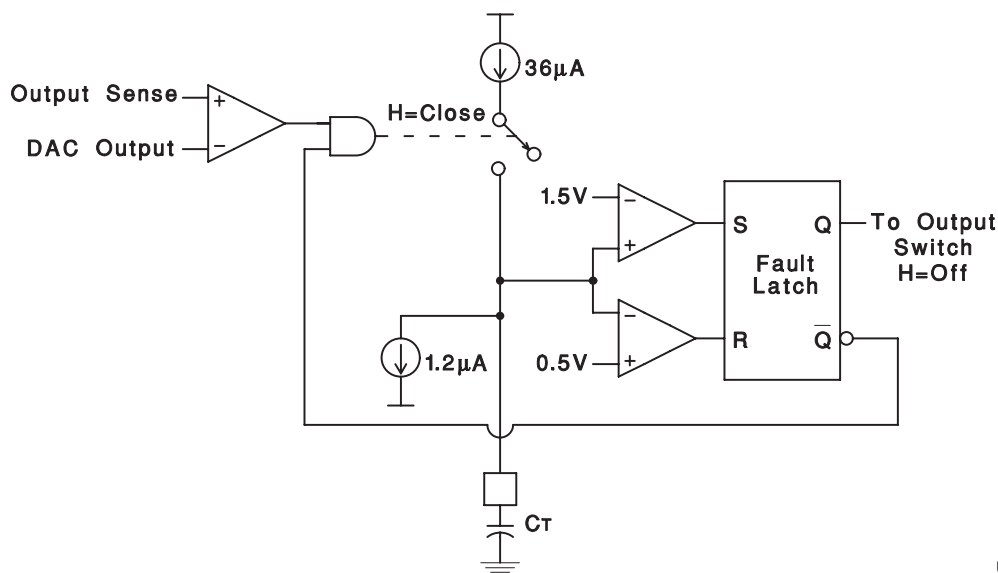

UDG-94019-1

Figure 3. UCC3912 On-Time Circuitry

**APPLICATION INFORMATION**

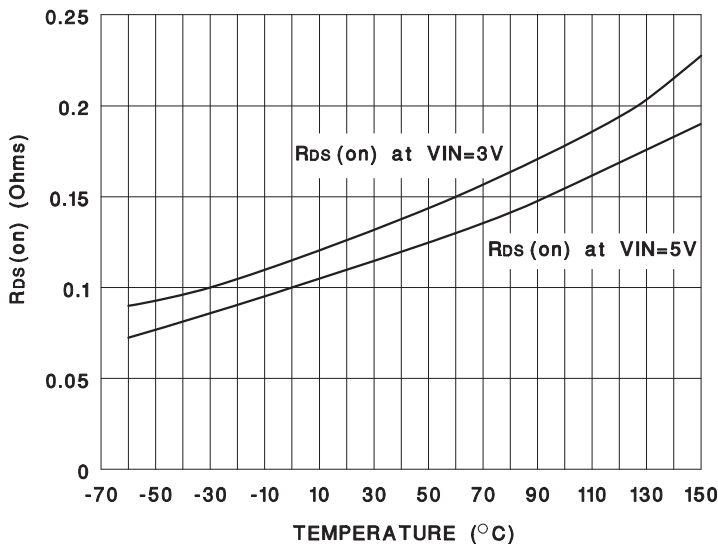

UDG-94019-1

**Figure 4. R<sub>DS(on)</sub> vs. Temperature at 2-A Load Current.**

**safety recommendations**

Although the UCC3912 family is designed to provide system protection for all fault conditions, all integrated circuits can ultimately fail short. For this reason, if the UCC3912 is intended for use in safety critical applications where UL or some other safety rating is required, a redundant safety device such as a fuse should be placed in series with the device. The UCC3912 will prevent the fuse from blowing virtually for all fault conditions, increasing system reliability and reducing maintenance cost, in addition to providing the hot swap benefits of the device.

**PACKAGING INFORMATION**

Orderable Device	Status (1)	Package Type	Package Drawing	Pins	Package Qty	Eco Plan (2)	Lead/Ball Finish (6)	MSL Peak Temp (3)	Op Temp (°C)	Device Marking (4/5)	Samples
UCC2912DP	ACTIVE	SOIC	D	16	40	Green (RoHS & no Sb/Br)	CU NIPDAU	Level-2-260C-1 YEAR	-40 to 85	UCC2912DP	<a href="#">Samples</a>
UCC2912PWP	ACTIVE	TSSOP	PW	24	60	Green (RoHS & no Sb/Br)	CU NIPDAU	Level-2-260C-1 YEAR	-40 to 85	UCC2912PWP	<a href="#">Samples</a>
UCC2912PWPG4	ACTIVE	TSSOP	PW	24	60	Green (RoHS & no Sb/Br)	CU NIPDAU	Level-2-260C-1 YEAR	-40 to 85	UCC2912PWP	<a href="#">Samples</a>
UCC3912DP	ACTIVE	SOIC	D	16	40	Green (RoHS & no Sb/Br)	CU NIPDAU	Level-2-260C-1 YEAR	0 to 70	UCC3912DP	<a href="#">Samples</a>
UCC3912DPG4	ACTIVE	SOIC	D	16	40	Green (RoHS & no Sb/Br)	CU NIPDAU	Level-2-260C-1 YEAR	0 to 70	UCC3912DP	<a href="#">Samples</a>
UCC3912DPTR	ACTIVE	SOIC	D	16	2500	Green (RoHS & no Sb/Br)	CU NIPDAU	Level-2-260C-1 YEAR	0 to 70	UCC3912DP	<a href="#">Samples</a>
UCC3912PWP	ACTIVE	TSSOP	PW	24	60	Green (RoHS & no Sb/Br)	CU NIPDAU	Level-2-260C-1 YEAR	0 to 70	UCC3912PWP	<a href="#">Samples</a>
UCC3912PWPG4	ACTIVE	TSSOP	PW	24	60	Green (RoHS & no Sb/Br)	CU NIPDAU	Level-2-260C-1 YEAR	0 to 70	UCC3912PWP	<a href="#">Samples</a>
UCC3912PWPTR	ACTIVE	TSSOP	PW	24	2000	Green (RoHS & no Sb/Br)	CU NIPDAU	Level-2-260C-1 YEAR	0 to 70	UCC3912PWP	<a href="#">Samples</a>
UCC3912PWPTRG4	ACTIVE	TSSOP	PW	24	2000	Green (RoHS & no Sb/Br)	CU NIPDAU	Level-2-260C-1 YEAR	0 to 70	UCC3912PWP	<a href="#">Samples</a>

(1) The marketing status values are defined as follows:

**ACTIVE:** Product device recommended for new designs.

**LIFEBUY:** TI has announced that the device will be discontinued, and a lifetime-buy period is in effect.

**NRND:** Not recommended for new designs. Device is in production to support existing customers, but TI does not recommend using this part in a new design.

**PREVIEW:** Device has been announced but is not in production. Samples may or may not be available.

**OBSOLETE:** TI has discontinued the production of the device.

(2) Eco Plan - The planned eco-friendly classification: Pb-Free (RoHS), Pb-Free (RoHS Exempt), or Green (RoHS & no Sb/Br) - please check <http://www.ti.com/productcontent> for the latest availability information and additional product content details.

**TBD:** The Pb-Free/Green conversion plan has not been defined.

**Pb-Free (RoHS):** TI's terms "Lead-Free" or "Pb-Free" mean semiconductor products that are compatible with the current RoHS requirements for all 6 substances, including the requirement that lead not exceed 0.1% by weight in homogeneous materials. Where designed to be soldered at high temperatures, TI Pb-Free products are suitable for use in specified lead-free processes.

**Pb-Free (RoHS Exempt):** This component has a RoHS exemption for either 1) lead-based flip-chip solder bumps used between the die and package, or 2) lead-based die adhesive used between the die and leadframe. The component is otherwise considered Pb-Free (RoHS compatible) as defined above.

**Green (RoHS & no Sb/Br):** TI defines "Green" to mean Pb-Free (RoHS compatible), and free of Bromine (Br) and Antimony (Sb) based flame retardants (Br or Sb do not exceed 0.1% by weight in homogeneous material)

- (3) MSL, Peak Temp. - The Moisture Sensitivity Level rating according to the JEDEC industry standard classifications, and peak solder temperature.
- (4) There may be additional marking, which relates to the logo, the lot trace code information, or the environmental category on the device.
- (5) Multiple Device Markings will be inside parentheses. Only one Device Marking contained in parentheses and separated by a "~" will appear on a device. If a line is indented then it is a continuation of the previous line and the two combined represent the entire Device Marking for that device.
- (6) Lead/Ball Finish - Orderable Devices may have multiple material finish options. Finish options are separated by a vertical ruled line. Lead/Ball Finish values may wrap to two lines if the finish value exceeds the maximum column width.

**Important Information and Disclaimer:**The information provided on this page represents TI's knowledge and belief as of the date that it is provided. TI bases its knowledge and belief on information provided by third parties, and makes no representation or warranty as to the accuracy of such information. Efforts are underway to better integrate information from third parties. TI has taken and continues to take reasonable steps to provide representative and accurate information but may not have conducted destructive testing or chemical analysis on incoming materials and chemicals. TI and TI suppliers consider certain information to be proprietary, and thus CAS numbers and other limited information may not be available for release.

In no event shall TI's liability arising out of such information exceed the total purchase price of the TI part(s) at issue in this document sold by TI to Customer on an annual basis.

## TAPE AND REEL INFORMATION



### QUADRANT ASSIGNMENTS FOR PIN 1 ORIENTATION IN TAPE



\*All dimensions are nominal

Device	Package Type	Package Drawing	Pins	SPQ	Reel Diameter (mm)	Reel Width W1 (mm)	A0 (mm)	B0 (mm)	K0 (mm)	P1 (mm)	W (mm)	Pin1 Quadrant
UCC3912DPTR	SOIC	D	16	2500	330.0	16.4	6.5	10.3	2.1	8.0	16.0	Q1
UCC3912PWPTR	TSSOP	PW	24	2000	330.0	16.4	6.95	8.3	1.6	8.0	16.0	Q1

**TAPE AND REEL BOX DIMENSIONS**

\*All dimensions are nominal

Device	Package Type	Package Drawing	Pins	SPQ	Length (mm)	Width (mm)	Height (mm)
UCC3912DPTR	SOIC	D	16	2500	367.0	367.0	38.0
UCC3912PWPTR	TSSOP	PW	24	2000	367.0	367.0	38.0

D (R-PDSO-G16)

PLASTIC SMALL OUTLINE



- NOTES:
- A. All linear dimensions are in inches (millimeters).
  - B. This drawing is subject to change without notice.
  - C. Body length does not include mold flash, protrusions, or gate burrs. Mold flash, protrusions, or gate burrs shall not exceed 0.006 (0,15) each side.
  - D. Body width does not include interlead flash. Interlead flash shall not exceed 0.017 (0,43) each side.
  - E. Reference JEDEC MS-012 variation AC.

PW (R-PDSO-G24)

PLASTIC SMALL OUTLINE

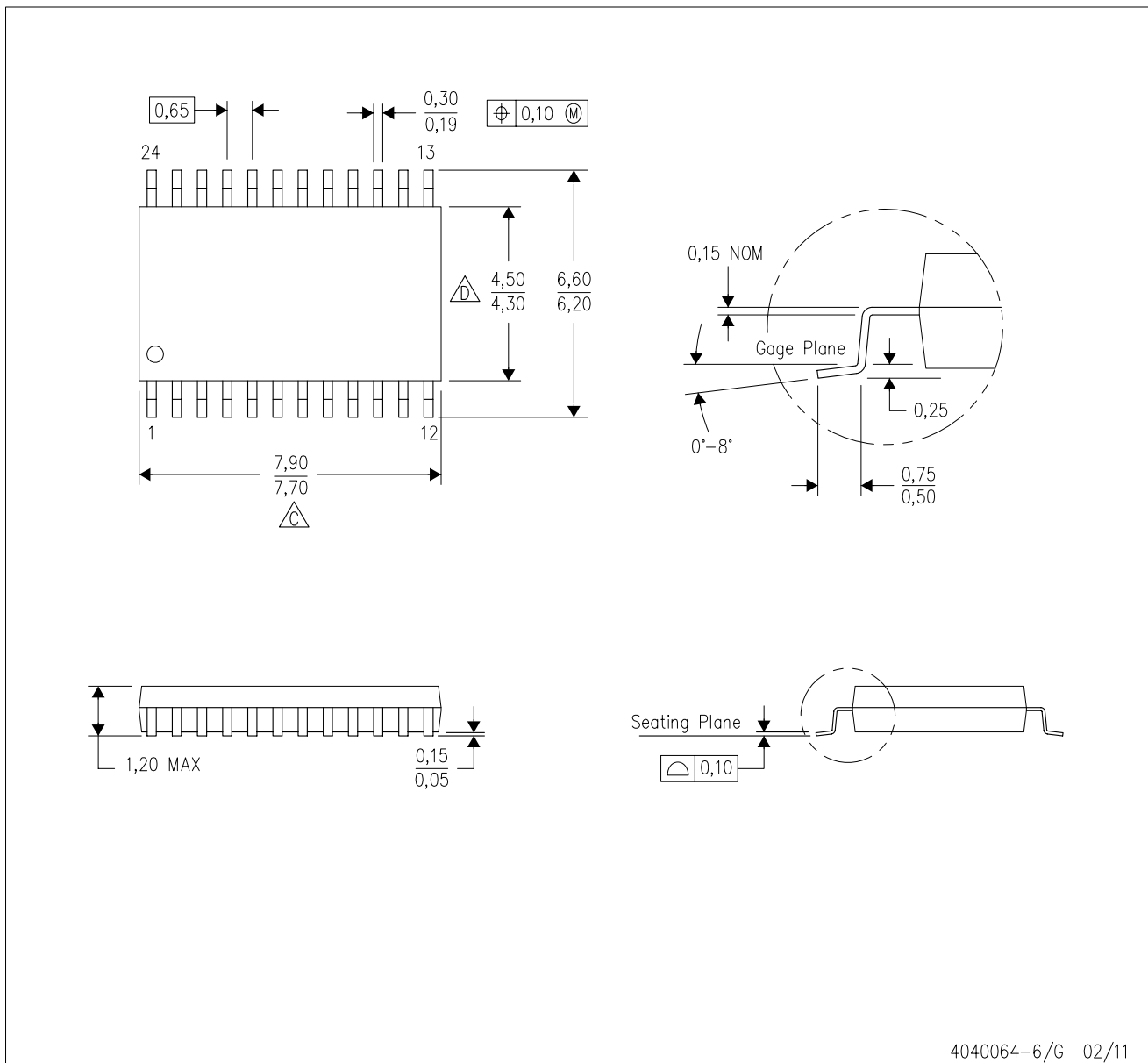

4040064-6/G 02/11

- NOTES:
- A. All linear dimensions are in millimeters. Dimensioning and tolerancing per ASME Y14.5M-1994.
  - B. This drawing is subject to change without notice.
  - Body length does not include mold flash, protrusions, or gate burrs. Mold flash, protrusions, or gate burrs shall not exceed 0,15 each side.
  - Body width does not include interlead flash. Interlead flash shall not exceed 0,25 each side.
  - E. Falls within JEDEC MO-153

PW (R-PDSO-G24)

PLASTIC SMALL OUTLINE

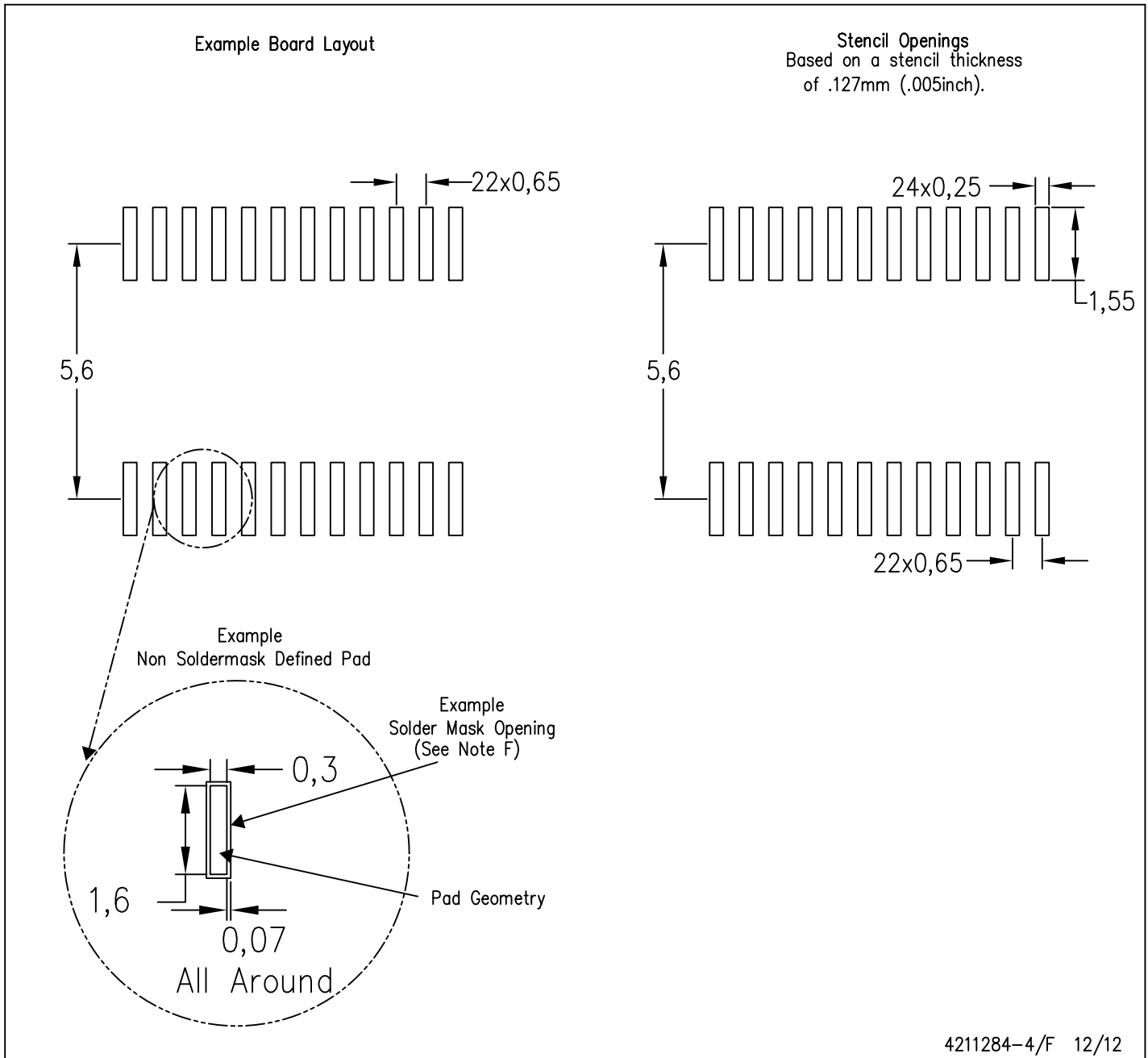

- NOTES:
- A. All linear dimensions are in millimeters.
  - B. This drawing is subject to change without notice.
  - C. Publication IPC-7351 is recommended for alternate design.
  - D. Laser cutting apertures with trapezoidal walls and also rounding corners will offer better paste release. Customers should contact their board assembly site for stencil design recommendations. Refer to IPC-7525 for other stencil recommendations.
  - E. Customers should contact their board fabrication site for solder mask tolerances between and around signal pads.

## IMPORTANT NOTICE

Texas Instruments Incorporated and its subsidiaries (TI) reserve the right to make corrections, enhancements, improvements and other changes to its semiconductor products and services per JESD46, latest issue, and to discontinue any product or service per JESD48, latest issue. Buyers should obtain the latest relevant information before placing orders and should verify that such information is current and complete. All semiconductor products (also referred to herein as "components") are sold subject to TI's terms and conditions of sale supplied at the time of order acknowledgment.

TI warrants performance of its components to the specifications applicable at the time of sale, in accordance with the warranty in TI's terms and conditions of sale of semiconductor products. Testing and other quality control techniques are used to the extent TI deems necessary to support this warranty. Except where mandated by applicable law, testing of all parameters of each component is not necessarily performed.

TI assumes no liability for applications assistance or the design of Buyers' products. Buyers are responsible for their products and applications using TI components. To minimize the risks associated with Buyers' products and applications, Buyers should provide adequate design and operating safeguards.

TI does not warrant or represent that any license, either express or implied, is granted under any patent right, copyright, mask work right, or other intellectual property right relating to any combination, machine, or process in which TI components or services are used. Information published by TI regarding third-party products or services does not constitute a license to use such products or services or a warranty or endorsement thereof. Use of such information may require a license from a third party under the patents or other intellectual property of the third party, or a license from TI under the patents or other intellectual property of TI.

Reproduction of significant portions of TI information in TI data books or data sheets is permissible only if reproduction is without alteration and is accompanied by all associated warranties, conditions, limitations, and notices. TI is not responsible or liable for such altered documentation. Information of third parties may be subject to additional restrictions.

Resale of TI components or services with statements different from or beyond the parameters stated by TI for that component or service voids all express and any implied warranties for the associated TI component or service and is an unfair and deceptive business practice. TI is not responsible or liable for any such statements.

Buyer acknowledges and agrees that it is solely responsible for compliance with all legal, regulatory and safety-related requirements concerning its products, and any use of TI components in its applications, notwithstanding any applications-related information or support that may be provided by TI. Buyer represents and agrees that it has all the necessary expertise to create and implement safeguards which anticipate dangerous consequences of failures, monitor failures and their consequences, lessen the likelihood of failures that might cause harm and take appropriate remedial actions. Buyer will fully indemnify TI and its representatives against any damages arising out of the use of any TI components in safety-critical applications.

In some cases, TI components may be promoted specifically to facilitate safety-related applications. With such components, TI's goal is to help enable customers to design and create their own end-product solutions that meet applicable functional safety standards and requirements. Nonetheless, such components are subject to these terms.

No TI components are authorized for use in FDA Class III (or similar life-critical medical equipment) unless authorized officers of the parties have executed a special agreement specifically governing such use.

Only those TI components which TI has specifically designated as military grade or "enhanced plastic" are designed and intended for use in military/aerospace applications or environments. Buyer acknowledges and agrees that any military or aerospace use of TI components which have **not** been so designated is solely at the Buyer's risk, and that Buyer is solely responsible for compliance with all legal and regulatory requirements in connection with such use.

TI has specifically designated certain components as meeting ISO/TS16949 requirements, mainly for automotive use. In any case of use of non-designated products, TI will not be responsible for any failure to meet ISO/TS16949.

### Products

Audio	<a href="http://www.ti.com/audio">www.ti.com/audio</a>
Amplifiers	<a href="http://amplifier.ti.com">amplifier.ti.com</a>
Data Converters	<a href="http://dataconverter.ti.com">dataconverter.ti.com</a>
DLP® Products	<a href="http://www.dlp.com">www.dlp.com</a>
DSP	<a href="http://dsp.ti.com">dsp.ti.com</a>
Clocks and Timers	<a href="http://www.ti.com/clocks">www.ti.com/clocks</a>
Interface	<a href="http://interface.ti.com">interface.ti.com</a>
Logic	<a href="http://logic.ti.com">logic.ti.com</a>
Power Mgmt	<a href="http://power.ti.com">power.ti.com</a>
Microcontrollers	<a href="http://microcontroller.ti.com">microcontroller.ti.com</a>
RFID	<a href="http://www.ti-rfid.com">www.ti-rfid.com</a>
OMAP Applications Processors	<a href="http://www.ti.com/omap">www.ti.com/omap</a>
Wireless Connectivity	<a href="http://www.ti.com/wirelessconnectivity">www.ti.com/wirelessconnectivity</a>

### Applications

Automotive and Transportation	<a href="http://www.ti.com/automotive">www.ti.com/automotive</a>
Communications and Telecom	<a href="http://www.ti.com/communications">www.ti.com/communications</a>
Computers and Peripherals	<a href="http://www.ti.com/computers">www.ti.com/computers</a>
Consumer Electronics	<a href="http://www.ti.com/consumer-apps">www.ti.com/consumer-apps</a>
Energy and Lighting	<a href="http://www.ti.com/energy">www.ti.com/energy</a>
Industrial	<a href="http://www.ti.com/industrial">www.ti.com/industrial</a>
Medical	<a href="http://www.ti.com/medical">www.ti.com/medical</a>
Security	<a href="http://www.ti.com/security">www.ti.com/security</a>
Space, Avionics and Defense	<a href="http://www.ti.com/space-avionics-defense">www.ti.com/space-avionics-defense</a>
Video and Imaging	<a href="http://www.ti.com/video">www.ti.com/video</a>

### TI E2E Community

[e2e.ti.com](http://e2e.ti.com)