

UCC28740 采用光电耦合器反馈的恒压、恒流反激控制器

1 特性

- 空载功耗低于 10mW
- 针对恒定电压 (CV) 的光耦反馈, 和针对恒定电流 (CC) 的初级侧调节 (PSR)
- 在线路和负载上实现 $\pm 1\%$ 电压调节和 $\pm 5\%$ 电流调节
- 700V 启动开关
- 100kHz 最大开关频率可实现高功率密度充电器设计
- 针对最高总体效率的谐振环谷值开关运行
- 简化电磁干扰 (EMI) 兼容性的频率抖动
- 针对金属氧化物半导体场效应晶体管 (MOSFET) 的已钳制栅极驱动输出
- 过压、低线路和过流保护功能
- 小外形尺寸集成电路 (SOIC)-7 封装

2 应用

- 用于消费类电子产品的 USB 兼容适配器和充电器
 - 智能电话
 - 平板电脑
 - 摄像机
- 针对电视和台式机的待机电源
- 白色家电

3 说明

UCC28740 隔离式反激电源控制器使用光耦合器来提供恒定电压 (CV), 从而改善对大型负载阶跃的瞬态响应。恒流 (CC) 调节通过一次侧稳压 (PSR) 技术来实现。此器件处理光耦反馈信息和来自辅助反激式绕组的信息, 以实现输出电压和电流的精准高性能控制。

内部采用 700V 启动开关, 可动态控制工作状态并定制调制配置文件, 支持超低待机功耗, 并且不会影响启动时间或输出瞬态响应。

UCC28740 中的控制算法使得运行效率满足或者超过适用标准。驱动输出接至一个 MOSFET 电源开关。带有谷值开关的断续传导模式 (DCM) 减少了开关损耗。开关频率的调制和初级电流峰值振幅 (FM 和 AM) 在整个负载和线路范围内保持较高的转换效率。

此控制器有一个 100kHz 的最大开关频率并且一直保持对变压器内峰值初级电流的控制。保护特性有助于抑制一次侧和二次侧应力分量。170Hz 的最小开关频率可轻松实现低于 10mW 的无负载功耗。

器件信息(1)

器件型号	封装	封装尺寸 (标称值)
UCC28740	SOIC (7)	4.90mm x 3.91mm

(1) 如需了解所有可用封装, 请见数据表末尾的可订购产品附录。

简化应用示意图

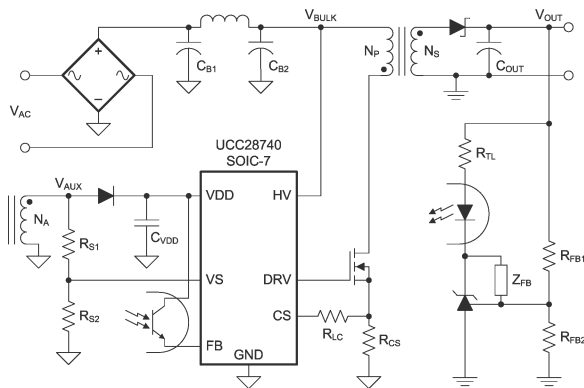

典型伏安图

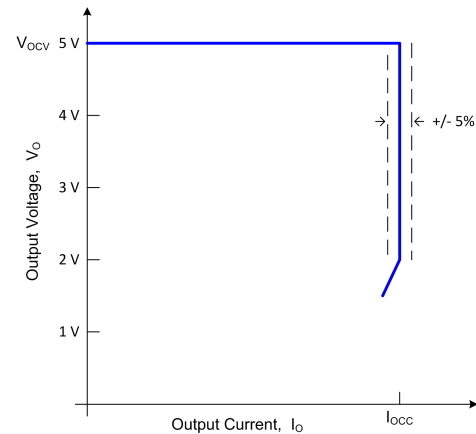

目录

1	特性	1	7.3	Feature Description	11
2	应用	1	7.4	Device Functional Modes	12
3	说明	1	8	Application and Implementation	17
4	修订历史记录	2	8.1	Application Information	17
5	Pin Configuration and Functions	3	8.2	Typical Application	17
	5.1 Detailed Pin Description	3	9	Power Supply Recommendations	27
6	Specifications	6	10	Layout	27
	6.1 Absolute Maximum Ratings	6	10.1	Layout Guidelines	27
	6.2 ESD Ratings	6	10.2	Layout Example	28
	6.3 Recommended Operating Conditions	6	11	器件和文档支持	29
	6.4 Thermal Information	6	11.1	器件支持	29
	6.5 Electrical Characteristics	7	11.2	商标	31
	6.6 Typical Characteristics	8	11.3	静电放电警告	31
7	Detailed Description	10	11.4	术语表	31
	7.1 Overview	10	12	机械、封装和可订购信息	31
	7.2 Functional Block Diagram	10			

4 修订历史记录

Changes from Revision A (July 2013) to Revision B	Page
<ul style="list-style-type: none"> 已添加 ESD 额定值表, 特性描述部分, 器件功能模式, 应用和实施部分, 电源相关建议部分, 布局部分, 器件和文档支持部分以及机械、封装和可订购信息部分 	1

Changes from Original (July 2013) to Revision A	Page
<ul style="list-style-type: none"> 已将销售状态从“产品预览”改为“量产数据” 	1

5 Pin Configuration and Functions

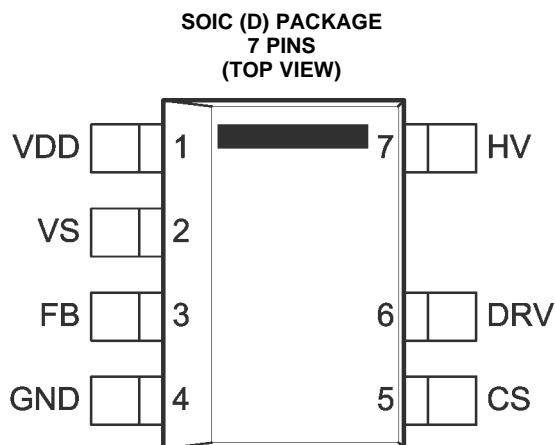

Pin Functions

PIN		I/O	DESCRIPTION
NAME	NO.		
CS	5	I	The current-sense (CS) input connects to a ground-referenced current-sense resistor in series with the power switch. The resulting voltage monitors and controls the peak primary current. A series resistor is added to this pin to compensate for peak switch-current levels as the AC-mains input varies.
DRV	6	O	Drive (DRV) is an output that drives the gate of an external high-voltage MOSFET switching transistor.
FB	3	I	The feedback (FB) input receives a current signal from the optocoupler output transistor. An internal current mirror divides the feedback current by 2.5 and applies it to an internal pullup resistor to generate a control voltage, V_{CL} . The voltage at this resistor directly drives the control law function, which determines the switching frequency and the peak amplitude of the switching current.
GND	4	—	The ground (GND) pin is both the reference pin for the controller, and the low-side return for the drive output. Special care must be taken to return all AC-decoupling capacitors as close as possible to this pin and avoid any common trace length with analog signal-return paths.
HV	7	I	The high-voltage (HV) pin may connect directly, or through a series resistor, to the rectified bulk voltage and provides a charge to the VDD capacitor for the startup of the power supply.
VDD	1	I	VDD is the bias-supply input pin to the controller. A carefully placed bypass capacitor to GND is required on this pin.
VS	2	I	Voltage sense (VS) is an input used to provide demagnetization timing feedback to the controller to limit frequency, to control constant-current operation, and to provide output-overvoltage detection. VS is also used for AC-mains input-voltage detection for peak primary-current compensation. This pin connects to a voltage divider between an auxiliary winding and GND. The value of the upper resistor of this divider programs the AC-mains run and stop thresholds, and factors into line compensation at the CS pin.

5.1 Detailed Pin Description

VDD (Device Bias Voltage Supply) The VDD pin connects to a bypass capacitor-to-ground. The turnon UVLO threshold is 21 V and turnoff UVLO threshold is 7.75 V with an available operating range up to 35 V on VDD. The typical USB-charging specification requires the output current to operate in constant-current mode from 5 V down to at least 2 V which is achieved easily with a nominal V_{VDD} of approximately 25 V. The additional VDD headroom up to 35 V allows for V_{VDD} to rise due to the leakage energy delivered to the VDD capacitor during high-load conditions.

GND (Ground) UCC28740 has a single ground reference external to the device for the gate-drive current and analog signal reference. Place the VDD-bypass capacitor close to GND and VDD with short traces to minimize noise on the VS, FB, and CS signal pins.

HV (High-Voltage Startup) The HV pin connects directly to the bulk capacitor to provide a startup current to the VDD capacitor. The typical startup current is approximately 250 μ A which provides fast charging of the VDD capacitor. The internal HV startup device is active until V_{VDD} exceeds the turnon UVLO

Detailed Pin Description (continued)

threshold of 21 V at which time the HV startup device turns off. In the off state the HV leakage current is very low to minimize standby losses of the controller. When V_{VDD} falls below the 7.75 V UVLO turnoff threshold the HV startup device turns on.

VS (Voltage Sense) The VS pin connects to a resistor-divider from the auxiliary winding to ground. The auxiliary voltage waveform is sampled at the end of the transformer secondary-current demagnetization time to provide accurate control of the output current when in constant-current mode. The waveform on the VS pin determines the timing information to achieve valley-switching, and the timing to control the duty-cycle of the transformer secondary current. Avoid placing a filter capacitor on this input which interferes with accurate sensing of this waveform.

During the MOSFET on-time, this pin also senses VS current generated through R_{S1} by the reflected bulk-capacitor voltage to provide for AC-input run and stop thresholds, and to compensate the current-sense threshold across the AC-input range. For the AC-input run/stop function, the run threshold on VS is 225 μ A and the stop threshold is 80 μ A.

At the end of off-time demagnetization, the reflected output voltage is sampled at this pin to provide output overvoltage protection. The values for the auxiliary voltage-divider upper-resistor, R_{S1} , and lower-resistor, R_{S2} , are determined by [Equation 1](#) and [Equation 2](#).

$$R_{S1} = \frac{V_{IN(run)} \times \sqrt{2}}{N_{PA} \times I_{VSL(run)}}$$

where

- N_{PA} is the transformer primary-to-auxiliary turns-ratio,
- $V_{IN(run)}$ is the AC RMS voltage to enable turnon of the controller (run), (in case of DC input, leave out the $\sqrt{2}$ term in the equation),
- $I_{VSL(run)}$ is the run-threshold for the current pulled out of the VS pin during the switch on-time (see [Electrical Characteristics](#)).

(1)

$$R_{S2} = \frac{R_{S1} \times V_{OVP}}{N_{AS} \times (V_{OV} - V_F) - V_{OVP}}$$

where

- V_{OV} is the maximum allowable peak voltage at the converter output,
- V_F is the output-rectifier forward drop at near-zero current,
- N_{AS} is the transformer auxiliary-to-secondary turns-ratio,
- R_{S1} is the VS divider high-side resistance,
- V_{OVP} is the overvoltage detection threshold at the VS input (see [Electrical Characteristics](#)).

(2)

FB (Feedback) The FB pin connects to the emitter of an analog-optocoupler output transistor which usually has the collector connected to VDD. The current supplied to FB by the optocoupler is reduced internally by a factor of 2.5 and the resulting current is applied to an internal 480-k Ω resistor to generate the control law voltage (V_{CL}). This V_{CL} directly determines the converter switching frequency and peak primary current required for regulation per the control-law for any given line and load condition.

DRV (Gate Drive) The DRV pin connects to the MOSFET gate pin, usually through a series resistor. The gate driver provides a gate-drive signal limited to 14 V. The turnon characteristic of the driver is a 25-mA current source which limits the turnon dv/dt of the MOSFET drain and reduces the leading-edge current spike while still providing a gate-drive current to overcome the Miller plateau. The gate-drive turnoff current is determined by the R_{DSON} of the low-side driver along with any external gate-drive resistance. Adding external gate resistance reduces the MOSFET drain turn-off dv/dt, if necessary.

CS (Current Sense) The current-sense pin connects through a series resistor (R_{LC}) to the current-sense resistor (R_{CS}). The maximum current-sense threshold ($V_{CST(max)}$) is 0.773 V for $I_{PP(max)}$, and the minimum current-sense threshold ($V_{CST(min)}$) is 0.194 V for $I_{PP(min)}$. R_{LC} provides the feed-forward line compensation to eliminate changes in I_{PP} with input voltage due to the propagation delay of the internal comparator and MOSFET turnoff time. An internal leading-edge blanking time of 235 ns eliminates sensitivity to the MOSFET turnon current spike. Placing a bypass capacitor on the CS

Detailed Pin Description (continued)

pin is unnecessary. The target output current in constant-current (CC) regulation determines the value of R_{CS} . The values of R_{CS} and R_{LC} are calculated using Equation 3 and Equation 4. The term V_{CCR} is the product of the demagnetization constant, 0.425, and $V_{CST(max)}$. V_{CCR} is held to a tighter accuracy than either of its constituent terms. The term η_{XFMR} accounts for the energy stored in the transformer but not delivered to the secondary. This term includes transformer resistance and core loss, bias power, and primary-to-secondary leakage ratio.

Example:

With a transformer core and winding loss of 5%, primary-to-secondary leakage inductance of 3.5%, and bias power to output power ratio of 0.5%, the η_{XFMR} value at full power is approximately: $1 - 0.05 - 0.035 - 0.005 = 0.91$.

$$R_{CS} = \frac{V_{CCR} \times N_{PS}}{2I_{OCC}} \times \sqrt{\eta_{XFMR}}$$

where

- V_{CCR} is a constant-current regulation factor (see [Electrical Characteristics](#)),
- N_{PS} is the transformer primary-to-secondary turns-ratio (a ratio of 13 to 15 is typical for 5-V output),
- I_{OCC} is the target output current in constant-current regulation,
- η_{XFMR} is the transformer efficiency at full power. (3)

$$R_{LC} = \frac{K_{LC} \times R_{S1} \times R_{CS} \times t_D \times N_{PA}}{L_P}$$

where

- R_{S1} is the VS pin high-side resistor value,
- R_{CS} is the current-sense resistor value,
- t_D is the total current-sense delay consisting of MOSFET turnoff delay, plus approximately 50 ns internal delay,
- N_{PA} is the transformer primary-to-auxiliary turns-ratio,
- L_P is the transformer primary inductance,
- K_{LC} is a current-scaling constant for line compensation (see [Electrical Characteristics](#)). (4)

6 Specifications

6.1 Absolute Maximum Ratings⁽¹⁾⁽²⁾

		MIN	MAX	UNIT
V _{HV}	Start-up pin voltage, HV		700	V
V _{VDD}	Bias supply voltage, VDD		38	
I _{DRV}	Continuous gate-current sink		50	mA
I _{DRV}	Continuous gate-current source		Self-limiting	
I _{FB}	Peak current, VS		1	
I _{VS}	Peak current, FB		-1.2	
V _{DRV}	Gate-drive voltage at DRV	-0.5	Self-limiting	V
Voltage	CS	-0.5	5	
	FB	-0.5	7	
	VS	-0.75	7	
T _J	Operating junction temperature	-55	150	°C
	Lead temperature 0.6 mm from case for 10 s		260	
T _{stg}	Storage temperature	-65	150	

- (1) Stresses beyond those listed under *Absolute Maximum Ratings* may cause permanent damage to the device. These are stress ratings only and functional operation of the device at these or any other conditions beyond those indicated under *Recommended Operating Conditions* is not implied. Exposure to absolute-maximum-rated conditions for extended periods may affect device reliability.
- (2) All voltages are with respect to GND. Currents are positive into, negative out of the specified terminal. These ratings apply over the operating ambient temperature ranges unless otherwise noted.

6.2 ESD Ratings

		VALUE	UNIT
V _(ESD)	Electrostatic discharge	Human-body model (HBM), per ANSI/ESDA/JEDEC JS-001 ⁽¹⁾	±2000
		Charged-device model (CDM), per JEDEC specification JESD22-C101 ⁽²⁾	±500

- (1) JEDEC document JEP155 states that 500-V HBM allows safe manufacturing with a standard ESD control process.
- (2) JEDEC document JEP157 states that 250-V CDM allows safe manufacturing with a standard ESD control process.

6.3 Recommended Operating Conditions

over operating free-air temperature range (unless otherwise noted)

		MIN	MAX	UNIT
V _{VDD}	Bias-supply operating voltage	9	35	V
C _{VDD}	VDD bypass capacitor	0.047		µF
I _{FB}	Feedback current, continuous		50	µA
I _{VS}	VS pin current, out of pin		1	mA
T _J	Operating junction temperature	-40	125	°C

6.4 Thermal Information

THERMAL METRIC ⁽¹⁾		UCC28740		UNIT
		D		
		7 PINS		
R _{θJA}	Junction-to-ambient thermal resistance	141.5		°C/W
R _{θJC(top)}	Junction-to-case (top) thermal resistance	73.8		
R _{θJB}	Junction-to-board thermal resistance	89.0		
ψ _{JT}	Junction-to-top characterization parameter	23.5		
ψ _{JB}	Junction-to-board characterization parameter	88.2		

- (1) For more information about traditional and new thermal metrics, see the *IC Package Thermal Metrics* application report, [SPRA953](#).

6.5 Electrical Characteristics

over operating free-air temperature range, $V_{DD} = 25\text{ V}$, HV = open, $V_{FB} = 0\text{ V}$, $V_{VS} = 4\text{ V}$, $T_A = -40^\circ\text{C}$ to $+125^\circ\text{C}$, $T_J = T_A$ (unless otherwise noted)

PARAMETER		TEST CONDITIONS	MIN	TYP	MAX	UNIT
HIGH-VOLTAGE START UP						
I_{HV}	Start-up current out of VDD	$V_{HV} = 100\text{ V}$, $V_{DD} = 0\text{ V}$, start state	100	250	500	μA
$I_{HVLKG25}$	Leakage current at HV	$V_{HV} = 400\text{ V}$, run state, $T_J = 25^\circ\text{C}$		0.01	0.5	
BIAS SUPPLY INPUT						
I_{RUN}	Supply current, run	$I_{DRV} = 0$, run state		2	2.65	mA
I_{WAIT}	Supply current, wait	$I_{DRV} = 0$, wait state		95	125	μA
I_{START}	Supply current, start	$I_{DRV} = 0$, $V_{DD} = 18\text{ V}$, start state, $I_{HV} = 0$		18	30	
I_{FAULT}	Supply current, fault	$I_{DRV} = 0$, fault state		95	130	
UNDERVOLTAGE LOCKOUT						
$V_{DD(on)}$	VDD turnon threshold	V_{DD} low to high	19	21	23	V
$V_{DD(off)}$	VDD turnoff threshold	V_{DD} high to low	7.35	7.75	8.15	
VS INPUT						
V_{VSNC}	Negative clamp level	$I_{VSL} = -300\text{ }\mu\text{A}$, volts below ground	190	250	325	mV
I_{VSB}	Input bias current	$V_{VS} = 4\text{ V}$	-0.25	0	0.25	μA
FB INPUT						
I_{FBMAX}	Full-range input current	$f_{SW} = f_{SW(min)}$	16	23	30	μA
V_{FBMAX}	Input voltage at full range	$I_{FB} = 25\text{ }\mu\text{A}$, $T_J = 25^\circ\text{C}$	0.75	0.88	1	V
R_{FB}	FB-input resistance, linearized	$\Delta I_{FB} = 20\text{ }\mu\text{A}$, centered at $I_{FB} = 15\text{ }\mu\text{A}$, $T_J = 25^\circ\text{C}$	10	14	18	k Ω
CS INPUT						
$V_{CST(max)}$	Maximum CS threshold voltage	$I_{FB} = 0\text{ }\mu\text{A}^{(1)}$	738	773	810	mV
$V_{CST(min)}$	Minimum CS threshold voltage	$I_{FB} = 35\text{ }\mu\text{A}^{(1)}$	170	194	215	
K_{AM}	AM-control ratio	$V_{CST(max)} / V_{CST(min)}$	3.6	4	4.45	V/V
V_{CCR}	Constant-current regulation factor		318	330	343	mV
K_{LC}	Line-compensation current ratio	$I_{VSL} = -300\text{ }\mu\text{A}$, $I_{VSL} /$ current out of CS pin	24	25	28.6	A/A
t_{CSLEB}	Leading-edge blanking time	DRV output duration, $V_{CS} = 1\text{ V}$	180	230	280	ns
DRIVERS						
I_{DRS}	DRV source current	$V_{DRV} = 8\text{ V}$, $V_{DD} = 9\text{ V}$	20	25		mA
R_{DRVLS}	DRV low-side drive resistance	$I_{DRV} = 10\text{ mA}$		6	12	Ω
V_{DRCL}	DRV clamp voltage	$V_{DD} = 35\text{ V}$		14	16	V
R_{DRVSS}	DRV pulldown in start-state		150	190	230	k Ω
TIMING						
$f_{SW(max)}$	Maximum switching frequency	$I_{FB} = 0\text{ }\mu\text{A}^{(1)}$	91	100	106	kHz
$f_{SW(min)}$	Minimum switching frequency	$I_{FB} = 35\text{ }\mu\text{A}^{(1)}$	140	170	210	Hz
t_{ZTO}	Zero-crossing timeout delay		1.8	2.1	2.55	μs
PROTECTION						
V_{OVP}	Overvoltage threshold	At VS input, $T_J = 25^\circ\text{C}^{(2)}$	4.52	4.6	4.71	V
V_{OCP}	Overcurrent threshold	At CS input	1.4	1.5	1.6	
$I_{VSL(run)}$	VS line-sense run current	Current out of VS pin increasing	190	225	275	μA
$I_{VSL(stop)}$	VS line-sense stop current	Current out of VS pin decreasing	70	80	100	
K_{VSL}	VS line sense ratio	$I_{VSL(run)} / I_{VSL(stop)}$	2.45	2.8	3.05	A/A
$T_{J(stop)}$	Thermal-shutdown temperature	Internal junction temperature		165		$^\circ\text{C}$

- This device automatically varies the control frequency and current sense thresholds to improve EMI performance. These threshold voltages and frequency limits represent average levels.
- The overvoltage threshold level at VS decreases with increasing temperature by $0.8\text{ mV}/^\circ\text{C}$. This compensation is included to reduce the power-supply output overvoltage detection variance over temperature.

6.6 Typical Characteristics

$V_{VDD} = 25\text{ V}$, $T_J = 25^\circ\text{C}$, unless otherwise noted.

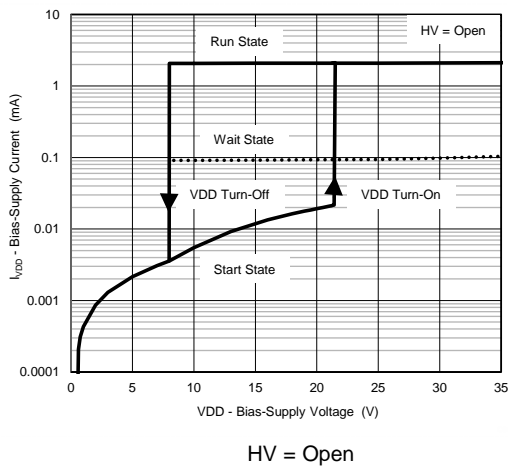

Figure 1. Bias-Supply Current vs. Bias-Supply Voltage

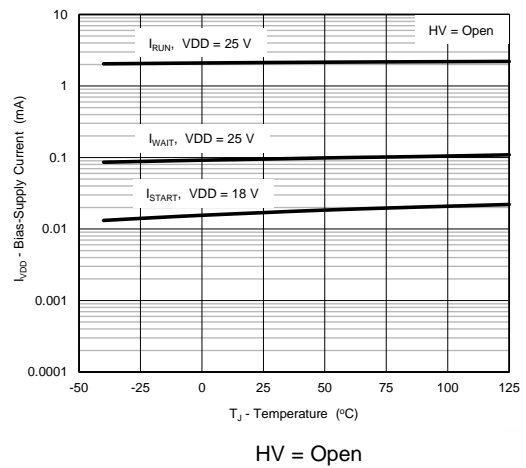

Figure 2. Bias-Supply Current vs. Temperature

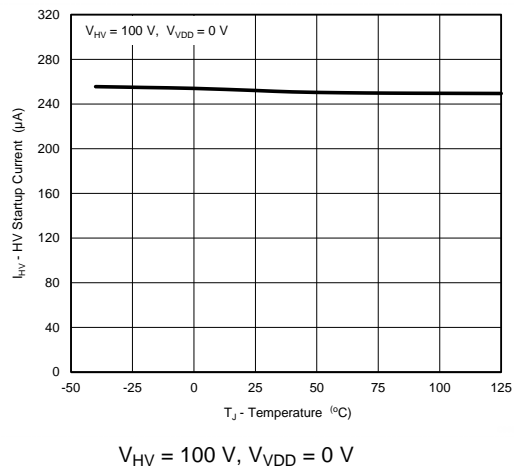

Figure 3. HV Startup Current vs. Temperature

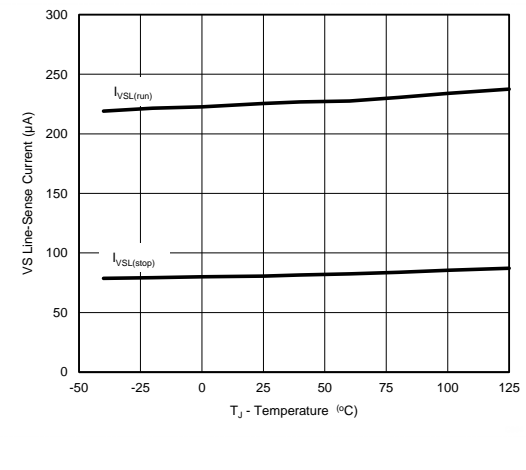

Figure 4. VS Line-Sense Currents vs. Temperature

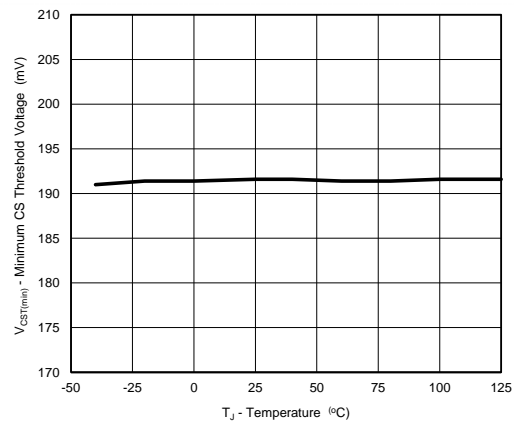

Figure 5. Minimum CS Threshold vs. Temperature

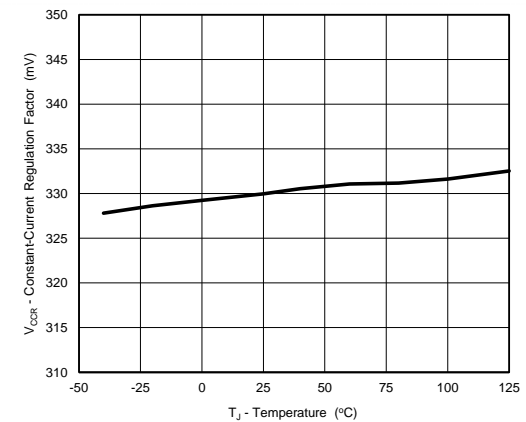

Figure 6. Constant-Current Regulation Factor vs. Temperature

Typical Characteristics (continued)

$V_{VDD} = 25\text{ V}$, $T_J = 25^\circ\text{C}$, unless otherwise noted.

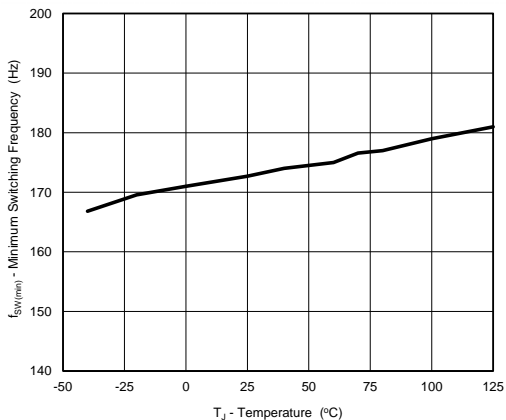
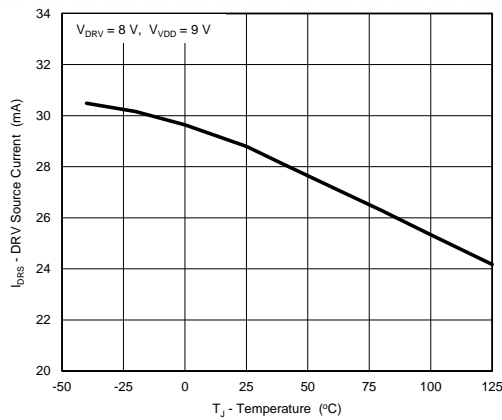

Figure 7. Minimum Switching Frequency vs. Temperature



$V_{DRV} = 8\text{ V}$, $V_{VDD} = 9\text{ V}$

Figure 8. DRV Source Current vs. Temperature

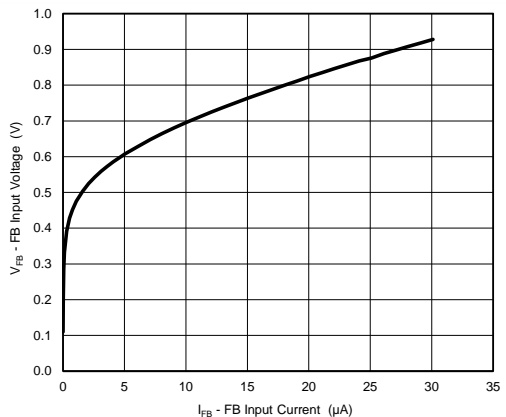

Figure 9. FB Input Voltage vs. FB Input Current

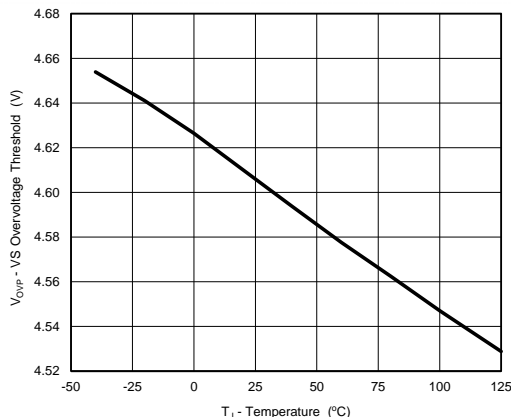

Figure 10. VS Overvoltage Threshold vs. Temperature

7.3 Feature Description

7.3.1 Valley-Switching and Valley-Skipping

The UCC28740 uses valley-switching to reduce switching losses in the MOSFET, to reduce induced-EMI, and to minimize the turnon current spike at the current-sense resistor. The controller operates in valley-switching in all load conditions unless the V_{DS} ringing diminishes to the point where valleys are no longer detectable.

As shown in Figure 11, the UCC28740 operates in a valley-skipping mode (also known as valley-hopping) in most load conditions to maintain an accurate voltage or current regulation point and still switch on the lowest available V_{DS} voltage.

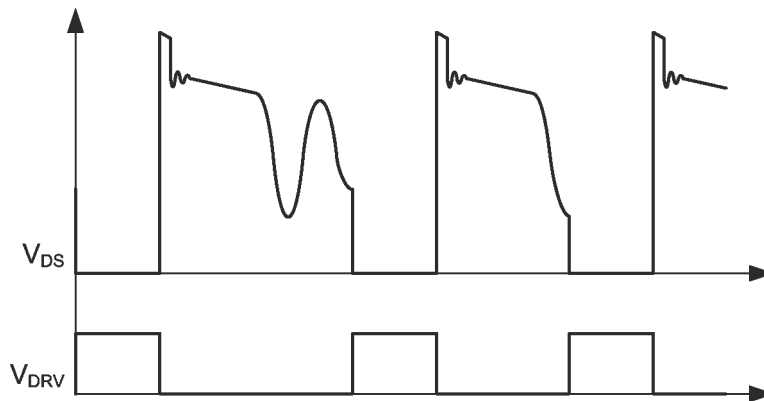

Figure 11. Valley-Skipping Mode

Valley-skipping modulates each switching cycle into discrete period durations. During FM operation, the switching cycles are periods when energy is delivered to the output in fixed packets, where the power-per-cycle varies discretely with the switching period. During operating conditions when the switching period is relatively short, such as at high-load and low-line, the average power delivered per cycle varies significantly based on the number of valleys skipped between cycles. As a consequence, valley-skipping adds additional ripple voltage to the output with a frequency and amplitude dependent upon the loop-response of the shunt-regulator. For a load with an average power level between that of cycles with fewer valleys skipped and cycles with more valleys skipped, the voltage-control loop modulates the FB current according to the loop-bandwidth and toggles between longer and shorter switching periods to match the required average output power.

7.3.2 Startup Operation

An internal high-voltage startup switch, connected to the bulk-capacitor voltage (V_{BULK}) through the HV pin, charges the VDD capacitor. This startup switch functions similarly to a current source providing typically 250 μ A to charge the VDD capacitor. When V_{VDD} reaches the 21-V UVLO turnon threshold the controller is enabled, the converter starts switching, and the startup switch turns off.

Often at initial turnon, the output capacitor is in a fully discharged state. The first three switching-cycle current peaks are limited to $I_{PP(min)}$ to monitor for any initial input or output faults with limited power delivery. After these three cycles, if the sampled voltage at VS is less than 1.33 V, the controller operates in a special startup mode. In this mode, the primary current peak amplitude of each switching cycle is limited to approximately $0.63 \times I_{PP(max)}$ and D_{MAGCC} increases from 0.425 to 0.735. These modifications to $I_{PP(max)}$ and D_{MAGCC} during startup allows high-frequency charge-up of the output capacitor to avoid audible noise while the demagnetization voltage is low. Once the sampled VS voltage exceeds 1.38 V, D_{MAGCC} is restored to 0.425 and the primary current peak resumes as $I_{PP(max)}$. While the output capacitor charges, the converter operates in CC mode to maintain a constant output current until the output voltage enters regulation. Thereafter, the controller responds to the condition dictated by the control law. The time to reach output regulation consists of the time the VDD capacitor charges to 21 V plus the time the output capacitor charges.

Feature Description (continued)

7.3.3 Fault Protection

The UCC28740 provides extensive fault protection. The protection functions include:

- Output overvoltage
- Input undervoltage
- Internal overtemperature
- Primary overcurrent fault
- CS-pin fault
- VS-pin fault

A UVLO reset and restart sequence applies to all fault-protection events.

The output-overvoltage function is determined by the voltage feedback on the VS pin. If the voltage sample of VS exceeds 4.6 V, the device stops switching and the internal current consumption becomes I_{FAULT} which discharges the VDD capacitor to the UVLO-turnoff threshold. After that, the device returns to the start state and a startup sequence ensues.

The UCC28740 always operates with cycle-by-cycle primary peak current control. The normal operating voltage range of the CS pin is 0.773 V to 0.194 V. An additional protection, not filtered by leading-edge blanking, occurs if the CS pin voltage reaches 1.5 V, which results in a UVLO reset and restart sequence.

Current into the VS pin during the MOSFET on-time determines the line-input run and stop thresholds. While the VS pin clamps close to GND during the MOSFET on-time, the current through R_{S1} is monitored to determine a sample of V_{BULK} . A wide separation of the run and stop thresholds allows for clean startup and shutdown of the power supply with the line voltage. The run-current threshold is 225 μA and the stop-current threshold is 80 μA .

The internal overtemperature-protection threshold is 165°C. If the junction temperature reaches this threshold the device initiates a UVLO-reset cycle. If the temperature is still high at the end of the UVLO cycle, the protection cycle repeats.

Protection is included in the event of component failures on the VS pin. If complete loss of feedback information on the VS pin occurs, the controller stops switching and restarts.

7.4 Device Functional Modes

7.4.1 Secondary-Side Optically Coupled Constant-Voltage (CV) Regulation

Figure 12 shows a simplified flyback convertor with the main output-regulation blocks of the device shown, along with typical implementation of secondary-side-derived regulation. The power-train operation is the same as any DCM-flyback circuit. A feedback current is optically coupled to the controller from a shunt-regulator sensing the output voltage.

Device Functional Modes (continued)

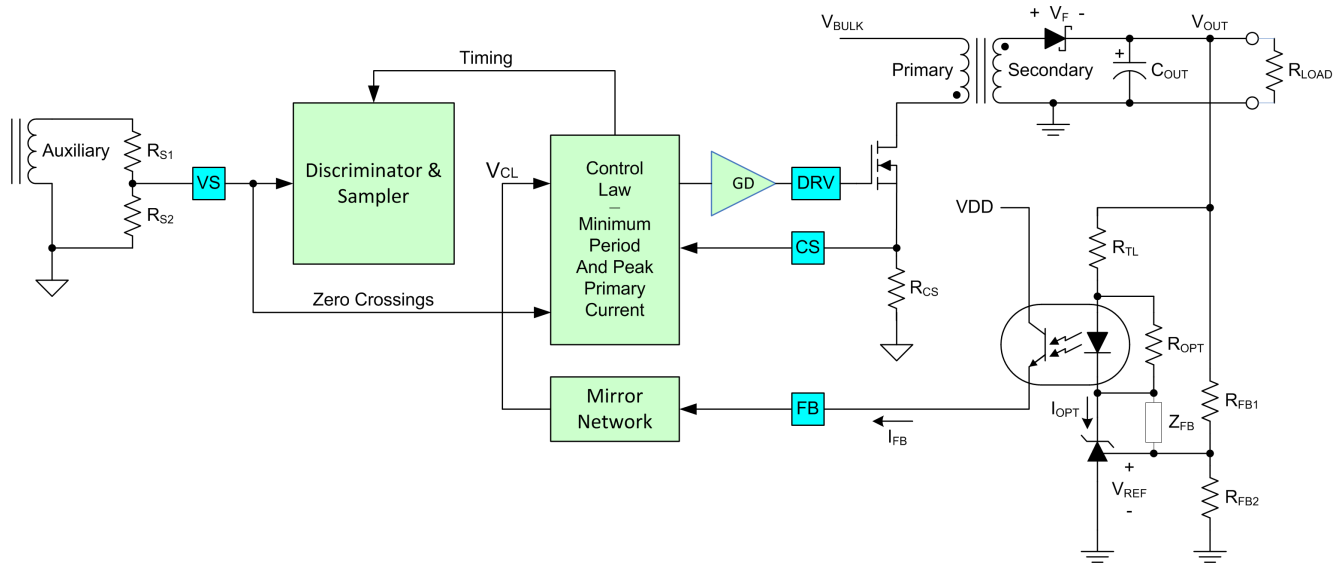

Figure 12. Simplified Flyback Converter (With the Main Voltage Regulation Blocks)

In this configuration, a secondary-side shunt-regulator, such as the TL431, generates a current through the input photo-diode of an optocoupler. The photo-transistor delivers a proportional current that is dependent on the current-transfer ratio (CTR) of the optocoupler to the FB input of the UCC28740 controller. This FB current then converts into the V_{CL} by the input-mirror network, detailed in the device block diagram (see [Functional Block Diagram](#)). Output-voltage variations convert to FB-current variations. The FB-current variations modify the V_{CL} which dictates the appropriate I_{PP} and f_{SW} necessary to maintain CV regulation. At the same time, the VS input senses the auxiliary winding voltage during the transfer of transformer energy to the secondary output to monitor for an output overvoltage condition. When f_{SW} reaches the target maximum frequency, chosen between 32 kHz and 100 kHz, CC operation is entered and further increases in V_{CL} have no effect.

Figure 13 shows that as the secondary current decreases to zero, a clearly defined down slope reflects the decreasing rectifier V_F combined with stray resistance voltage-drop ($I_S R_S$). To achieve an accurate representation of the secondary output voltage on the auxiliary winding, the discriminator reliably blocks the leakage-inductance reset and ringing while continuously sampling the auxiliary voltage during the down slope after the ringing diminishes. The discriminator then captures the voltage signal at the moment that the secondary-winding current reaches zero. The internal overvoltage threshold on VS is 4.6 V. Temperature compensation of -0.8 mV/°C on the overvoltage threshold offsets the change in the output-rectifier forward voltage with temperature. The resistor divider is selected as outlined in the VS pin description (see [Detailed Pin Description](#)).

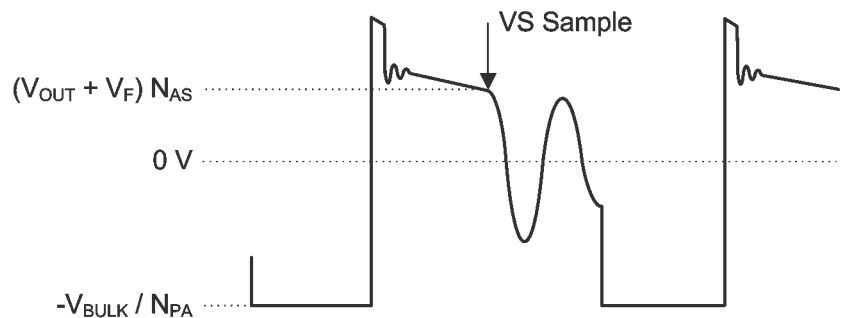

Figure 13. Auxiliary-Winding Voltage

Device Functional Modes (continued)

The UCC28740 VS-signal sampler includes signal-discrimination methods to ensure an accurate sample of the output voltage from the auxiliary winding. Controlling some details of the auxiliary-winding signal to ensure reliable operation is necessary; specifically, the reset time of the leakage inductance and the duration of any subsequent leakage-inductance ringing. See [Figure 14](#) for a detailed illustration of waveform criteria to ensure a reliable sample on the VS pin.

The first detail to examine is the duration of the leakage-inductance reset pedestal, t_{LK_RESET} , in [Figure 14](#). Because t_{LK_RESET} mimics the waveform of the secondary-current decay, followed by a sharp downslope, t_{LK_RESET} is internally blanked for a duration which scales with the peak primary current. Keeping the leakage-reset time to less than 600 ns for $I_{PP(min)}$, and less than 2.2 μ s for $I_{PP(max)}$ is important.

The second detail is the amplitude of ringing on the V_{AUX} waveform following t_{LK_RESET} . The peak-to-peak voltage variation at the VS pin must be less than 100 mVp-p for at least 200 ns before the end of the demagnetization time (t_{DM}). A concern with excessive ringing usually occurs during light or no-load conditions, when t_{DM} is at the minimum. The tolerable ripple on VS is scaled up to the auxiliary-winding voltage by R_{S1} and R_{S2} , and is equal to $100\text{ mV} \times (R_{S1} + R_{S2}) / R_{S2}$.

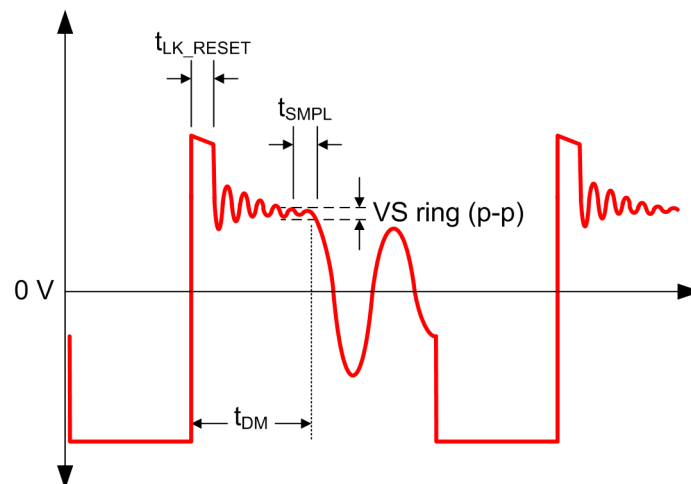

Figure 14. Auxiliary-Winding Waveform Details

During voltage regulation, the controller operates in frequency-modulation mode and amplitude-modulation mode, as shown in [Figure 15](#). The internal operating-frequency limits of the device are 100 kHz and $f_{SW(min)}$. The maximum operating frequency of the converter at full-load is generally chosen to be slightly lower than 100 kHz to allow for tolerances, or significantly lower due to switching-loss considerations. The maximum operating frequency and primary peak current chosen determine the transformer primary inductance of the converter. The shunt-regulator bias power, output preload resistor (if any), and low-power conversion efficiency determine the minimum-operating frequency of the converter. Voltage-loop stability compensation is applied at the shunt-regulator which drives the opto-coupled feedback signal. The tolerances chosen for the shunt-regulator reference and the sense resistors determines the regulation accuracy.

Device Functional Modes (continued)

Control-Law Profile in Constant-Voltage (CV) Mode

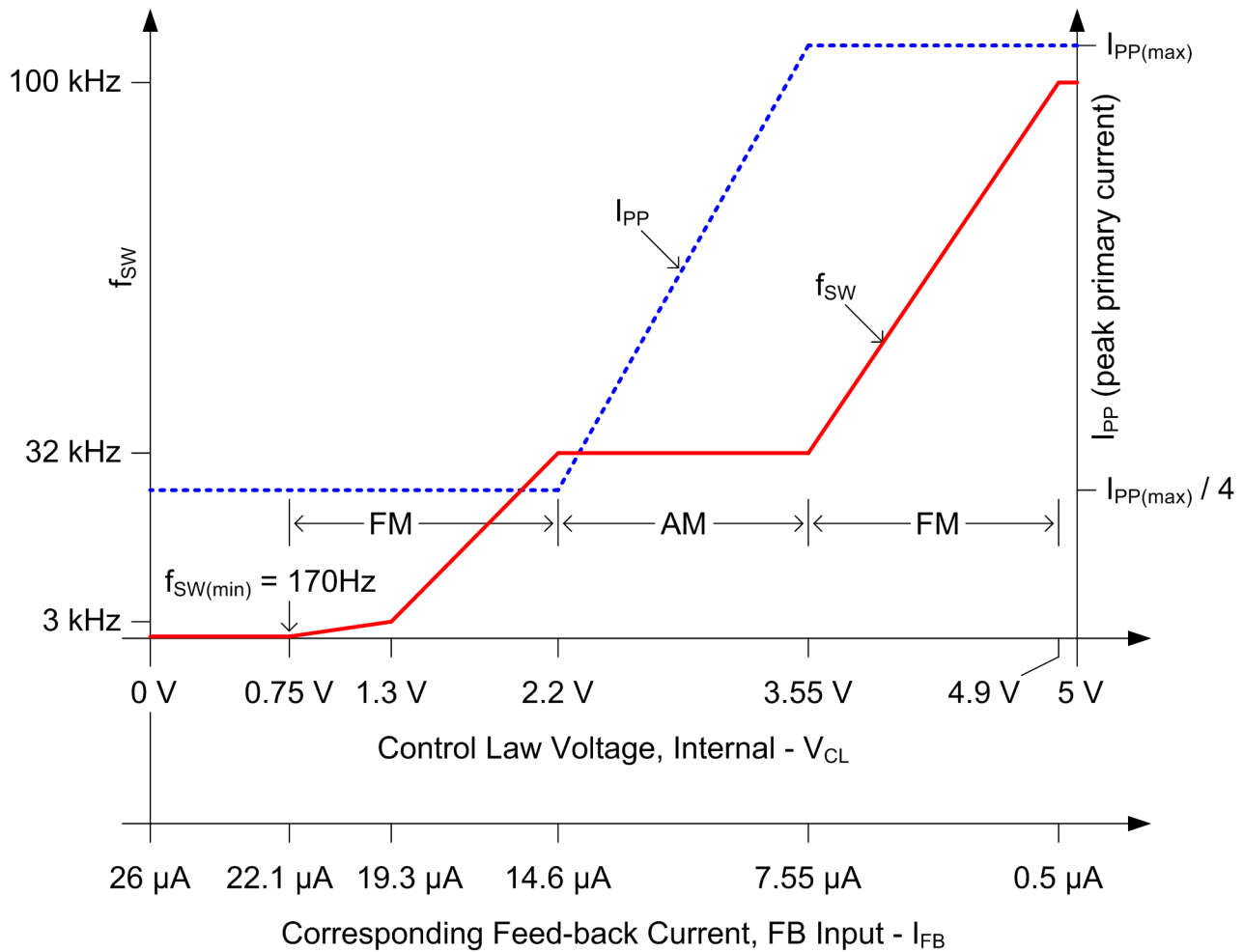

Figure 15. Frequency and Amplitude Modulation Modes (During CV Regulation)

The level of feedback current (I_{FB}) into the FB pin determines the internal V_{CL} which determines the operating point of the controller while in CV mode. When I_{FB} rises above 22 μA , no further decrease in f_{sw} occurs. When the output-load current increases to the point where maximum f_{sw} is reached, control transfers to CC mode. All current, voltage, frequency, breakpoints, and curve-segment linearity depicted in Figure 15 are nominal. Figure 15 indicates the general operation of the controller while in CV mode, although minor variations may occur from part to part. An internal frequency-dithering mechanism is enabled when I_{FB} is less than 14.6 μA to help reduce conducted EMI (including during CC-mode operation), and is disabled otherwise.

7.4.2 Primary-Side Constant-Current (CC) Regulation

When the load current of the converter increases to the predetermined constant-current limit, operation enters CC mode. In CC mode, output voltage regulation is lost and the shunt-regulator drives the current and voltage at FB to minimum. During CC mode, timing information at the VS pin and current information at the CS pin allow accurate regulation of the average current of the secondary winding. The CV-regulation control law dictates that as load increases approaches CC regulation the primary peak current will be at $I_{PP(max)}$. The primary peak current, turns-ratio, demagnetization time t_{DM} , and switching period t_{SW} determine the secondary average output current (see Figure 16). Ignoring leakage-inductance effects, the average output current is given by Equation 5. When the demagnetization duty-cycle reaches the CC-regulation reference, D_{MAGCC} , in the current-control block,

Device Functional Modes (continued)

the controller operates in frequency modulation (FM) mode to control the output current for any output voltage at or below the voltage-regulation target as long as the auxiliary winding keeps V_{VDD} above the UVLO turnoff threshold. As the output voltage falls, t_{DM} increases. The controller acts to increase t_{SW} to maintain the ratio of t_{DM} to switching period (t_{DM} / t_{SW}) at a maximum of 0.425 (D_{MAGCC}), thereby maintaining a constant average output current.

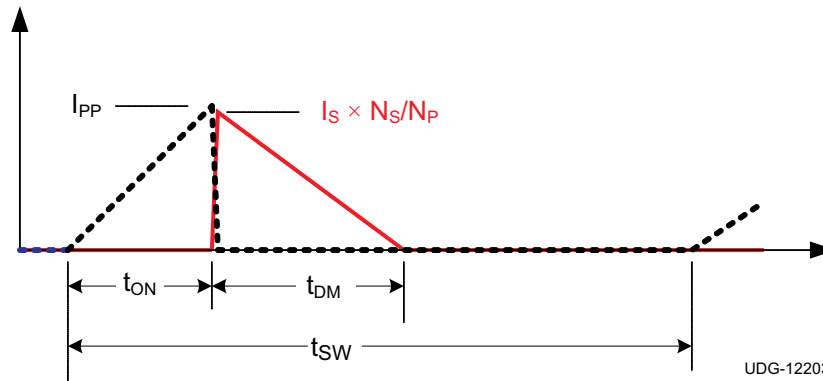
Figure 16. Transformer-Current Relationship

$$I_{OUT} = \frac{I_{PP}}{2} \times \frac{N_P}{N_S} \times \frac{t_{DM}}{t_{SW}} \quad (5)$$

Fast, accurate, opto-coupled CV control combined with line-compensated PSR CC control results in high-performance voltage and current regulation which minimizes voltage deviations due to heavy load and unload steps, as illustrated by the V-I curve in [Figure 17](#).

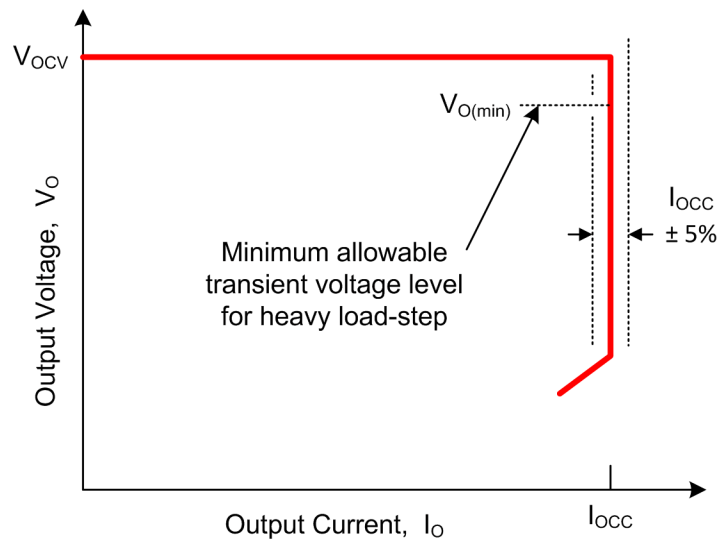
Figure 17. Typical Target Output V-I Characteristic

8 Application and Implementation

NOTE

Information in the following applications sections is not part of the TI component specification, and TI does not warrant its accuracy or completeness. TI's customers are responsible for determining suitability of components for their purposes. Customers should validate and test their design implementation to confirm system functionality.

8.1 Application Information

The UCC28740 is a flyback controller that provides constant-voltage (CV) mode control and constant current (CC) mode control for precise output regulation. While in CV operating range, the controller uses an opto-coupler for tight voltage regulation and improved transient response to large load steps. Accurate regulation while in CC mode is provided by primary side control. The UCC28740 uses frequency modulation, peak primary current modulation, valley switching and valley hopping in its control algorithm in order to maximize efficiency over the entire operating range.

8.2 Typical Application

The UCC28740 is well suited for use in isolated off-line systems requiring high efficiency and fault protection features such as USB compliant adapters and chargers for consumer electronics such as smart phones, tablet computers, and cameras. A 10-W application for a USB charger is shown in Figure 18.

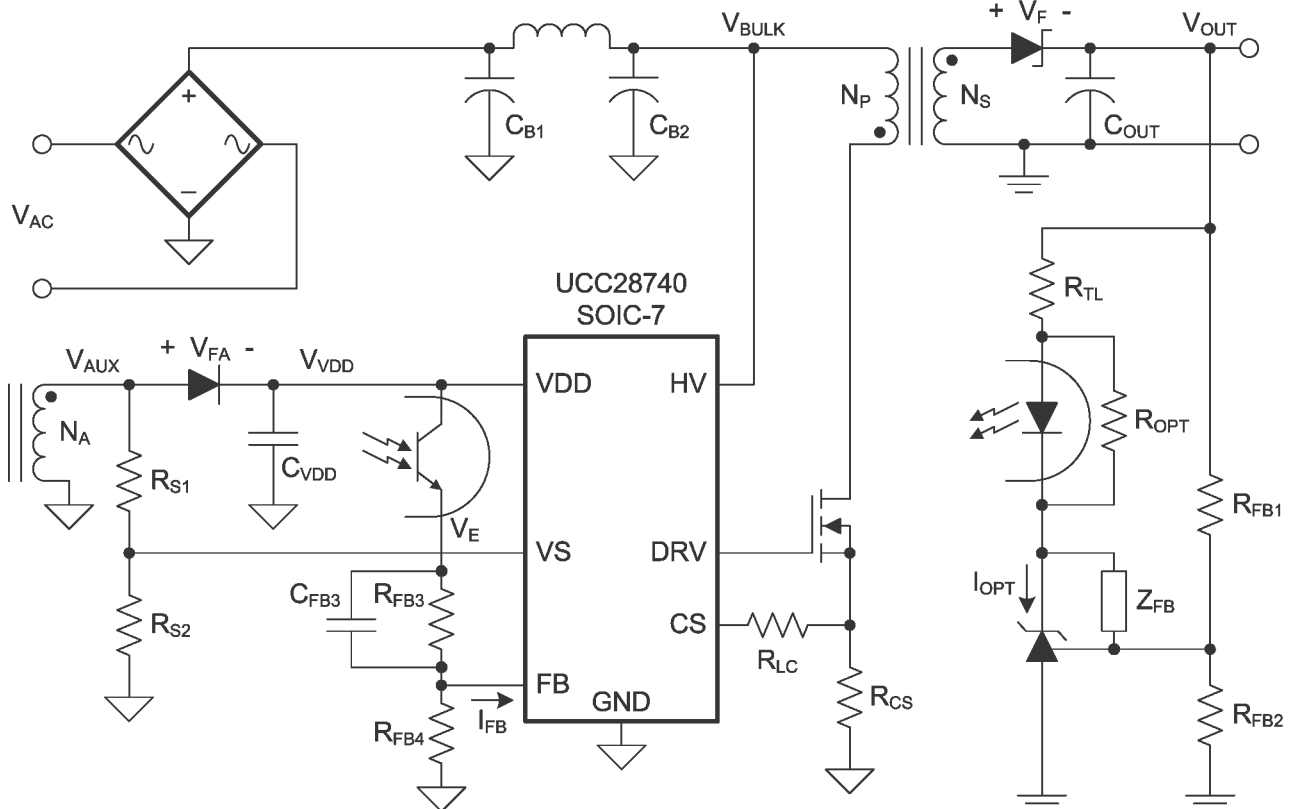

Figure 18. Design Procedure Application Example

Typical Application (continued)

8.2.1 Design Requirements

Table 1. Design Parameters

PARAMETER	NOTES AND CONDITIONS	MIN	NOM	MAX	UNIT
INPUT CHARACTERISTICS					
Input Voltage, V_{IN}		85	115/230	265	V_{RMS}
Maximum Input Current	$V_{IN} = V_{INmin}, I_{OUT} = I_{OUTmax}$		0.265		A_{RMS}
Line Frequency		47	60/50	63	Hz
No Load Input Power Consumption	$V_{INmin} \leq V_{IN} \leq V_{INmax}, I_{OUT} = 0 A$			20	mW
OUTPUT CHARACTERISTICS					
Output Voltage, V_{OUT}	$V_{INmin} \leq V_{IN} \leq V_{INmax}, 0 A \leq I_{OUT} \leq I_{OUTmax}$	4.95	5	5.05	V
Output Load Current, CV Mode, I_{OUTmax}	$V_{INmin} \leq V_{IN} \leq V_{INmax}$	1.995	2.1	2.205	A
Output Voltage Regulation	Line Regulation: $V_{INmin} \leq V_{IN} \leq V_{INmax}, I_{OUT} \leq I_{OUTmax}$		0.1%		
	Load Regulation: $0 A \leq I_{OUT} \leq I_{OUTmax}$		0.1%		
Output Voltage Ripple	$V_{INmin} \leq V_{IN} \leq V_{INmax}, 0 A \leq I_{OUT} \leq I_{OUTmax}$			150	mVpp
Output Overcurrent, I_{OCC}	$V_{INmin} \leq V_{IN} \leq V_{INmax}$			2.5	A
Minimum Output Voltage, CC Mode	$V_{INmin} \leq V_{IN} \leq V_{INmax}, I_{OUT} = I_{OCC}$		1.78	2	V
Brown-out Protection	$I_{OUT} = I_{OUTmax}$		68		V_{RMS}
Transient Response Undershoot	$I_{OUT} = I_{OUTmax}$ to 0-A load transient	4.3			V
Transient Response Time	$I_{OUT} = I_{OUTmax}$ to 0-A load transient			20	ms
SYSTEMS CHARACTERISTICS					
Switching Frequency, f_{SW}		1.2		71	kHz
Average Efficiency	25%, 50%, 75%, 100% load average at nominal input voltages		81%		
Operating Temperature			25		°C

8.2.2 Detailed Design Procedure

This procedure outlines the steps to design a constant-voltage, constant-current flyback converter using the UCC28740 controller. See [Figure 18](#) for component names and network locations. The design procedure equations use terms that are defined below.

8.2.2.1 Standby Power Estimate and No-Load Switching Frequency

Assuming minimal no-load standby power is a critical design requirement, determine the estimated no-load power loss based on an accounting of all no-load operating and leakage currents at their respective voltages. Close attention to detail is necessary to account for all of the sources of leakage, however, in many cases, prototype measurement is the only means to obtain a realistic estimation of total primary and secondary leakage currents. At present, converter standby power is certified by compliance-agency authorities based on steady-state room-temperature operation at the highest nominal input voltage rating (typically 230 Vrms).

[Equation 6](#) estimates the standby power loss from the sum of all leakage currents of the primary-side components of the converter. These leakage currents are measured in aggregate by disconnecting the HV input of the controller from the bulk-voltage rail to prevent operating currents from interfering with the leakage measurement.

$$P_{PRI_SB} = V_{BULK} \times \sum_{k=1}^{n_p} I_{PRI_LK_k} \quad (6)$$

Equation 7 estimates the standby power loss from the sum of all leakage and operating currents of the secondary-side components on the output of the converter. Leakage currents result from reverse voltage applied across the output rectifier and capacitors, while the operating current includes currents required by the shunt-regulator, optocoupler, and associated components.

$$P_{\text{SEC_SB}} = V_{\text{OCV}} \times \sum_{k=1}^{n_s} I_{\text{SEC}_k} \quad (7)$$

Equation 8 estimates the standby power loss from the sum of all leakage and operating currents of the auxiliary-side components on the controller of the converter. Leakage currents of the auxiliary diode and capacitor are usually negligible. The operating current includes the wait-state current, I_{WAIT} , of the UCC28740 controller, plus the optocoupler-output current for the FB network in the steady-state no-load condition. The VDD voltage in the no-load condition V_{VDDNL} are the lowest practicable value to minimize loss.

$$P_{\text{AUX_SB}} = V_{\text{VDDNL}} \times \sum_{k=1}^{n_a} I_{\text{AUX}_k} \quad (8)$$

Note that $P_{\text{PRI_SB}}$ is the only loss that is not dependent on transformer conversion efficiency. $P_{\text{SEC_SB}}$ and $P_{\text{AUX_SB}}$ are processed through the transformer and incur additional losses as a consequence. Typically, the transformer no-load conversion efficiency η_{SWNL} lies in the range of 0.50 to 0.70. Total standby input power (no-load condition) is estimated by **Equation 9**.

$$P_{\text{SB}} = P_{\text{PRI_SB}} + \frac{1}{\eta_{\text{SWNL}}} (P_{\text{SEC_SB}} + P_{\text{AUX_SB}}) \quad (9)$$

Although the UCC28740 is capable of operating at the minimum switching frequency of 170 Hz, a typical converter is likely to require a higher frequency to sustain operation at no-load. An accurate estimate of the no-load switching frequency f_{SWNL} entails a thorough accounting of all switching-related energy losses within the converter including parasitic elements of the power-train components. In general, f_{SWNL} is likely to lie within the range of 400 Hz to 800 Hz. A more detailed treatment of standby power and no-load frequency is beyond the scope of this data sheet.

8.2.2.2 Input Bulk Capacitance and Minimum Bulk Voltage

Determine the minimum voltage on the input bulk capacitance, C_{B1} and C_{B2} total, in order to determine the maximum Np-to-Ns turns-ratio of the transformer. The input power of the converter based on target full-load efficiency, the minimum input RMS voltage, and the minimum AC input frequency determine the input capacitance requirement.

Maximum input power is determined based on I_{OCC} , V_{OCV} , V_{CBC} (if used), and the full-load conversion-efficiency target.

$$P_{\text{IN}} = \frac{(V_{\text{OCV}} + V_{\text{CBC}}) \times I_{\text{OCC}}}{\eta} \quad (10)$$

Equation 11 provides an accurate solution for the total input capacitance based on a target minimum bulk-capacitor voltage. Alternatively, to target a given input capacitance value, iterate the minimum capacitor voltage to achieve the target capacitance value.

$$C_{\text{BULK}} = \frac{2P_{\text{IN}} \times \left(0.25 + \frac{1}{2\pi} \times \arcsin \left(\frac{V_{\text{BULK(min)}}}{\sqrt{2} \times V_{\text{IN(min)}}} \right) \right)}{\left(2V_{\text{IN(min)}}^2 - V_{\text{BULK(min)}}^2 \right) \times f_{\text{LINE}}} \quad (11)$$

8.2.2.3 Transformer Turns-Ratio, Inductance, Primary Peak Current

The target maximum switching frequency at full-load, the minimum input-capacitor bulk voltage, and the estimated DCM quasi-resonant time determine the maximum primary-to-secondary turns-ratio of the transformer.

Initially determine the maximum-available total duty-cycle of the on-time and secondary conduction time based on the target switching frequency, f_{MAX} , and DCM resonant time. For DCM resonant frequency, assume 500 kHz if an estimate from previous designs is not available. At the transition-mode operation limit of DCM, the interval required from the end of secondary current conduction to the first valley of the V_{DS} voltage is $\frac{1}{2}$ of the DCM resonant period (t_R), or 1 μ s assuming 500 kHz resonant frequency. The maximum allowable MOSFET on-time D_{MAX} is determined using [Equation 12](#).

$$D_{MAX} = 1 - D_{MAGCC} - \left(\frac{t_R}{2} \times f_{MAX} \right) \quad (12)$$

When D_{MAX} is known, the maximum primary-to-secondary turns-ratio is determined with [Equation 13](#). D_{MAGCC} is defined as the secondary-diode conduction duty-cycle during CC operation and is fixed internally by the UCC28740 at 0.425. The total voltage on the secondary winding must be determined, which is the sum of V_{OCV} , V_F , and V_{OCBC} . For the 5-V USB-charger applications, a turns ratio range of 13 to 15 is typically used.

$$N_{PS(max)} = \frac{D_{MAX} \times V_{BULK(min)}}{D_{MAGCC} \times (V_{OCV} + V_F + V_{OCBC})} \quad (13)$$

A higher turns-ratio generally improves efficiency, but may limit operation at low input voltage. Transformer design iterations are generally necessary to evaluate system-level performance trade-offs. When the optimum turns-ratio N_{PS} is determined from a detailed transformer design, use this ratio for the following parameters.

The UCC28740 constant-current regulation is achieved by maintaining D_{MAGCC} at the maximum primary peak current setting. The product of D_{MAGCC} and $V_{CST(max)}$ defines a CC-regulating voltage factor V_{CCR} which is used with N_{PS} to determine the current-sense resistor value necessary to achieve the regulated CC target, I_{OCC} (see [Equation 14](#)).

Because a small portion of the energy stored in the transformer does not transfer to the output, a transformer-efficiency term is included in the R_{CS} equation. This efficiency number includes the core and winding losses, the leakage-inductance ratio, and a bias-power to maximum-output-power ratio. An overall-transformer efficiency of 0.91 is a good estimate based on 3.5% leakage inductance, 5% core & winding loss, and 0.5% bias power, for example. Adjust these estimates as appropriate based on each specific application.

$$R_{CS} = \frac{V_{CCR} \times N_{PS}}{2I_{OCC}} \times \sqrt{\eta_{XFMR}} \quad (14)$$

The primary transformer inductance is calculated using the standard energy storage equation for flyback transformers. Primary current, maximum switching frequency, output voltage and current targets, and transformer power losses are included in [Equation 16](#).

First, determine the transformer primary peak current using [Equation 15](#). Peak primary current is the maximum current-sense threshold divided by the current-sense resistance.

$$I_{PP(max)} = \frac{V_{CST(max)}}{R_{CS}} \quad (15)$$

$$L_P = \frac{2(V_{OCV} + V_F + V_{OCBC}) \times I_{OCC}}{\eta_{XFMR} \times I_{PP(max)}^2 \times f_{MAX}} \quad (16)$$

N_{AS} is determined by the lowest target operating output voltage while in constant-current regulation and by the VDD UVLO turnoff threshold of the UCC28740. Additional energy is supplied to VDD from the transformer leakage-inductance which allows a lower turns ratio to be used in many designs.

$$N_{AS} = \frac{V_{VDD(off)} + V_{FA}}{V_{OCC} + V_F} \quad (17)$$

8.2.2.4 Transformer Parameter Verification

Because the selected transformer turns-ratio affects the MOSFET V_{DS} and the secondary and auxiliary rectifier reverse voltages, a review of these voltages is important. In addition, internal timing constraints of the UCC28740 require a minimum on time of the MOSFET (t_{ON}) and a minimum demagnetization time (t_{DM}) of the transformer in the high-line minimum-load condition. The selection of f_{MAX} , L_P , and R_{CS} affects the minimum t_{ON} and t_{DM} .

Equation 18 and Equation 19 determine the reverse voltage stresses on the secondary and auxiliary rectifiers. Stray inductance can impress additional voltage spikes upon these stresses and snubbers may be necessary.

$$V_{REVS} = \frac{V_{IN(max)} \times \sqrt{2}}{N_{PS}} \times V_{OV} \quad (18)$$

$$V_{REVA} = \frac{V_{IN(max)} \times \sqrt{2}}{N_{PA}} \times V_{VDD} \quad (19)$$

For the MOSFET V_{DS} peak voltage stress, an estimated leakage inductance voltage spike (V_{LK}) is included.

$$V_{DSPK} = (V_{IN(max)} \times \sqrt{2}) + (V_{OCV} + V_F + V_{OCBC}) \times N_{PS} + V_{LK} \quad (20)$$

Equation 21 determines if $t_{ON(min)}$ exceeds the minimum t_{ON} target of 280 ns (maximum t_{CSLEB}). Equation 22 verifies that $t_{DM(min)}$ exceeds the minimum t_{DM} target of 1.2 μ s.

$$t_{ON(min)} = \frac{L_P}{V_{IN(max)} \times \sqrt{2}} \times \frac{I_{PP(max)}}{K_{AM}} \quad (21)$$

$$t_{DM(min)} = \frac{t_{ON(min)} \times V_{IN(max)} \times \sqrt{2}}{N_{PS} \times (V_{OCV} + V_F)} \quad (22)$$

8.2.2.5 VS Resistor Divider, Line Compensation

The VS divider resistors determine the output overvoltage detection point of the flyback converter. The high-side divider resistor (R_{S1}) determines the input-line voltage at which the controller enables continuous DRV operation. R_{S1} is determined based on transformer primary-to-auxiliary turns-ratio and desired input voltage operating threshold.

$$R_{S1} = \frac{V_{IN(run)} \times \sqrt{2}}{N_{PA} \times I_{VSL(run)}} \quad (23)$$

The low-side VS pin resistor is then selected based on the desired overvoltage limit, V_{OV} .

$$R_{S2} = \frac{R_{S1} \times V_{OVP}}{N_{AS} \times (V_{OV} - V_F) - V_{OVP}} \quad (24)$$

The UCC28740 maintains tight constant-current regulation over varying input line by using the line-compensation feature. The line-compensation resistor (R_{LC}) value is determined by current flowing in R_{S1} and the total internal gate-drive and external MOSFET turnoff delay. Assume an internal delay of 50 ns in the UCC28740.

$$R_{LC} = \frac{K_{LC} \times R_{S1} \times R_{CS} \times t_D \times N_{PA}}{L_P} \quad (25)$$

8.2.2.6 Output Capacitance

The output capacitance value is often determined by the transient-response requirement from the no-load condition. For example, in typical low-power USB-charger applications, there is a requirement to maintain a minimum transient V_O of 4.1 V with a load-step I_{TRAN} from 0 mA to 500 mA. Yet new higher-performance applications require smaller transient voltage droop $V_{O\Delta}$ with I_{TRAN} of much greater amplitude (such as from no-load to full-load), which drives the need for high-speed opto-coupled voltage feedback.

$$C_{OUT} \geq \frac{I_{TRAN} \times t_{RESP}}{V_{OA}}$$

where

- t_{RESP} is the time delay from the moment I_{TRAN} is applied to the moment when I_{FB} falls below 1 μ A (26)

Additional considerations for the selection of appropriate output capacitors include ripple-current, ESR, and ESL ratings necessary to meet reliability and ripple-voltage requirements. Detailed design criteria for these considerations are beyond the scope of this datasheet.

8.2.2.7 VDD Capacitance, C_{VDD}

The capacitance on VDD must supply the primary-side operating current used during startup and between low-frequency switching pulses. The largest result of three independent calculations denoted in Equation 27, Equation 28, and Equation 29 determines the value of C_{VDD} .

At startup, when $V_{VDD(on)}$ is reached, C_{VDD} alone supplies the device operating current and MOSFET gate current until the output of the converter reaches the target minimum-operating voltage in CC regulation, V_{OCC} . Now the auxiliary winding sustains VDD for the UCC28740 above UVLO. The total output current available to the load and to charge the output capacitors is the CC-regulation target, I_{OCC} . Equation 27 assumes that *all* of the output current of the converter is available to charge the output capacitance until V_{OCC} is achieved. For typical applications, Equation 27 includes an estimated $q_G f_{SW(max)}$ of average gate-drive current and a 1-V margin added to V_{VDD} .

$$C_{VDD} \geq \frac{(I_{RUN} + q_G f_{SW(max)}) \times C_{OUT} \times V_{OCC}}{V_{VDD(on)} - (V_{VDD(off)} + 1V)} \quad (27)$$

During a worst-case un-load transient event from full-load to no-load, C_{OUT} overcharges above the normal regulation level for a duration of t_{OV} , until the output shunt-regulator loading is able to drain V_{OUT} back to regulation. During t_{OV} , the voltage feedback loop and optocoupler are saturated, driving maximum I_{FB} and temporarily switching at $f_{SW(min)}$. The auxiliary bias current expended during this situation exceeds that normally required during the steady-state no-load condition. Equation 28 calculates the value of C_{VDD} (with a safety factor of 2) required to ride through the t_{OV} duration until steady-state no-load operation is achieved.

$$C_{VDD} \geq \frac{2 \times I_{AUXNL(max)} \times t_{OV}}{V_{VDDFL} - (V_{VDD(off)} + 1V)} \quad (28)$$

Finally, in the steady-state no-load operating condition, total no-load auxiliary-bias current, I_{AUXNL} is provided by the converter switching at a no-load frequency, f_{SWNL} , which is generally higher than $f_{SW(min)}$. C_{VDD} is calculated to maintain a target VDD ripple voltage lower than ΔV_{VDD} , using Equation 29.

$$C_{VDD} \geq \frac{I_{AUXNL} \times \frac{1}{f_{SWNL}}}{\Delta V_{VDD}} \quad (29)$$

8.2.2.8 Feedback Network Biasing

Achieving very low standby power while maintaining high-performance load-step transient response requires careful design of the feedback network. Optically coupled secondary-side regulation is used to provide the rapid response needed when a heavy load step occurs during the no-load condition. One of the most commonly used devices to drive the optocoupler is the TL431 shunt-regulator, due to its simplicity, regulation performance, and low cost. This device requires a minimum bias current of 1 mA to maintain regulation accuracy. Together with the UCC28740 primary-side controller, careful biasing will ensure less than 30 mW of standby power loss at room temperature. Where a more stringent standby loss limit of less than 10 mW is required, the TLV431 device is recommended due to its minimum 80- μ A bias capability.

Facilitating these low standby-power targets is the approximate 23- μ A range of the FB input for full to no-load voltage regulation. The control-law profile graph (see [Figure 15](#)) shows that for FB-input current greater than 22 μ A, no further reduction in switching frequency is possible. Therefore, minimum power is converted at $f_{SW(min)}$. However, the typical minimum steady-state operating frequency tends to be in the range of several-hundred Hertz, and consequently the maximum steady-state FB current at no-load will be less than I_{FBMAX} . Even so, prudent design practice dictates that I_{FBMAX} should be used for conservative steady-state biasing calculations. At this current level, V_{FBMAX} can be expected at the FB input.

Referring to the Design Procedure Application Example in [Figure 18](#), the main purpose of R_{FB4} is to speed up the turnoff time of the optocoupler in the case of a heavy load-step transient condition. The value of R_{FB4} is determined empirically due to the variable nature of the specific optocoupler chosen for the design, but tends to fall within the range of 10 k Ω to 100 k Ω . A tradeoff must be made between a lower value for faster transient response and a higher value for lower standby power. R_{FB4} also serves to set a minimum bias current for the optocoupler and to drain dark current.

It is important to understand the distinction between *steady-state* no-load bias currents and voltages which affect standby power, and the varying extremes of these same currents and voltages which affect regulation during transient conditions. Design targets for minimum standby loss and maximum transient response often result in conflicting requirements for component values. Trade-offs, such as for R_{FB4} as discussed previously, must be made.

During standby operation, the total auxiliary current (used in [Equation 8](#)) is the sum of I_{WAIT} into the IC and the no-load optocoupler-output current I_{CENL} . This optocoupler current is given by [Equation 30](#).

$$I_{CENL} = I_{FBMAX} + \frac{V_{FBMAX}}{R_{FB4}} \quad (30)$$

For fast response, the optocoupler-output transistor is biased to minimize the variation of V_{CE} between full-load and no-load operation. Connecting the emitter directly to the FB input of the UCC28740 is possible, however, an unload-step response may unavoidably drive the optocoupler into saturation which will overload the FB input with full VDD applied. A series-resistor R_{FB3} is necessary to limit the current into FB and to avoid excess draining of C_{VDD} during this type of transient situation. The value of R_{FB3} is chosen to limit the excess I_{FB} and R_{FB4} current to an acceptable level when the optocoupler is saturated. Like R_{FB4} , the R_{FB3} value is also chosen empirically during prototype evaluation to optimize performance based on the conditions present during that situation. A starting value may be estimated using [Equation 31](#).

$$R_{FB3} = \frac{V_{VDDNL} - 1V}{I_{CENL}} \quad (31)$$

Note that R_{FB3} is estimated based on the expected no-load VDD voltage, but full-load VDD voltage will be higher resulting in initially higher I_{CE} current during the unload-step transient condition. Because R_{FB3} is interposed between V_E and the FB input, the optocoupler transistor V_{CE} varies considerably more as I_{CE} varies and transient response time is reduced. Capacitor C_{FB3} across R_{FB3} helps to improve the transient response again. The value of C_{FB3} is estimated initially by equating the $R_{FB3}C_{FB3}$ time constant to 1 ms, and later is adjusted higher or lower for optimal performance during prototype evaluation.

The optocoupler transistor-output current I_{CE} is proportional to the optocoupler diode input current by its current transfer ratio, CTR. Although many optocouplers are rated with nominal CTR between 50% and 600%, or are ranked into narrower ranges, the actual CTR obtained at the low currents used with the UCC28740 falls around 5% to 15%. At full-load regulation, when I_{FB} is near zero, V_{FB} is still approximately 0.4 V and this sets a minimum steady-state current for I_{CE} through R_{FB4} . After choosing an optocoupler, the designer must characterize its CTR over the range of low output currents expected in this application, because optocoupler data sheets rarely include such information. The actual CTR obtained is required to determine the diode input current range at the secondary-side shunt-regulator.

Referring again to [Figure 18](#), the shunt-regulator (typically a TL431) current must be at least 1 mA even when almost no optocoupler diode current flows. Since even a near-zero diode current establishes a forward voltage, R_{OPT} is selected to provide the minimum 1-mA regulator bias current. The optocoupler input diode must be characterized by the designer to obtain the actual forward voltage versus forward current at the low currents expected. At the full-load condition of the converter, I_{FB} is around 0.5 μ A, I_{CE} may be around $(0.4 \text{ V} / R_{FB4})$, and CTR at this level is about 10%, so the diode current typically falls in the range of 25 μ A to 100 μ A. Typical optodiode forward voltage at this level is about 0.97 V which is applied across R_{OPT} . If R_{OPT} is set equal to 1 k Ω , this provides 970 μ A plus the diode current for I_{OPT} .

As output load decreases, the voltage across the shunt-regulator also decreases to increase the current through the optocoupler diode. This increases the diode forward voltage across R_{OPT} . CTR at no-load (when I_{CE} is higher) is generally a few percent higher than CTR at full-load (when I_{CE} is lower). At steady-state no-load condition, the shunt-regulator current is maximized and can be estimated by [Equation 30](#) and [Equation 32](#). I_{OPTNL} , plus the sum of the leakage currents of all the components on the output of the converter, constitute the total current required for use in [Equation 7](#) to estimate secondary-side standby loss.

$$I_{OPTNL} = \frac{I_{CENL}}{CTR_{NL}} + \frac{V_{OPTNL}}{R_{OPT}} \quad (32)$$

The shunt-regulator voltage can decrease to a minimum, saturated level of about 2 V. To prevent excessive diode current, a series resistor, R_{TL} , is added to limit I_{OPT} to the maximum value necessary for regulation. [Equation 33](#) provides an estimated initial value for R_{TL} , which may be adjusted for optimal limiting later during the prototype evaluation process.

$$R_{TL} = \frac{V_{OUTNL} - V_{OPTNL} - 2V}{I_{OPTNL}} \quad (33)$$

The output-voltage sense-network resistors R_{FB1} and R_{FB2} are calculated in the usual manner based on the shunt-regulator reference voltage and input bias current. Having characterized the optocoupler at low currents and determined the initial values of R_{FB1} , R_{FB2} , R_{FB3} , R_{FB4} , C_{FB3} , R_{OPT} and R_{TL} using the above procedure, the DC-bias states of the feedback network can be established for steady-state full-load and no-load conditions. Adjustments of these initial values may be necessary to accommodate variations of the UCC28740, optocoupler, and shunt-regulator parameters for optimal overall performance.

The shunt-regulator compensation network, Z_{FB} , is determined using well-established design techniques for control-loop stability. Typically, a type-II compensation network is used. The compensation design procedure is beyond the scope of this datasheet.

8.2.3 Application Curves

The transient response shown in [Figure 19](#) was taken with a 115 VAC, 60 Hz input voltage and a load transition from 0 A to full load. Channel 1 is the load current on a scale of 1 A per division, channel 4 is the output voltage on a scale of 1 V per division. The cursor shows the minimum acceptable voltage limit, 4.30 V, under transient conditions. Also note that the output waveform was taken with the probe on TP5 with the ground referenced to TP4 but not using the tip and barrel technique accounting for the high frequency noise seen on the waveform.

The typical switching waveform can be seen in [Figure 20](#). Channel 1 shows the VS pin at 2 V per division and channel 2 shows the MOSFET drain to source voltage at 100 V per division. The scan was taken at 1.8-A load, 115-VAC, 60-Hz input voltage. At this operating point, the switching frequency is dithering between 58.8 kHz and 52.6 kHz due to valley skipping.

The UCC28740 controller employs a unique control mechanism to help with EMI compliance. As shown in [Figure 21](#), the DRV pin, shown as channel 3, drives the gate of the MOSFET with a sequence of pulses in which there will be two longer pulses, two medium pulses, and two shorter pulses at any operating point starting with the amplitude modulation mode. The EMI dithering is not enabled at light load. Figure x shows the result of these varying pulse widths on the CS signal, shown on channel 4. The longer pulses result in a peak current threshold of 808 mV, the medium length pulses are shown measured at 780 mV, and the shorter pulses measure a threshold voltage of 752 mV. This dithering adds to the frequency jitter caused by valley skipping and results in a spread spectrum for better EMI compliance.

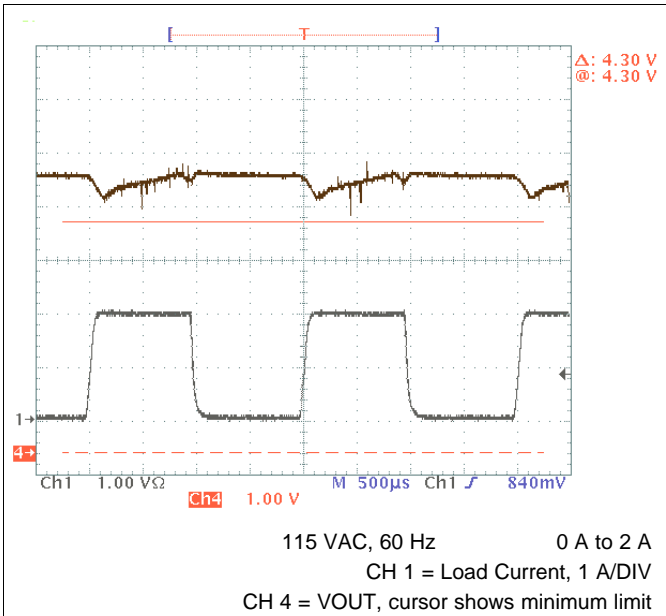

Figure 19. Transient Response

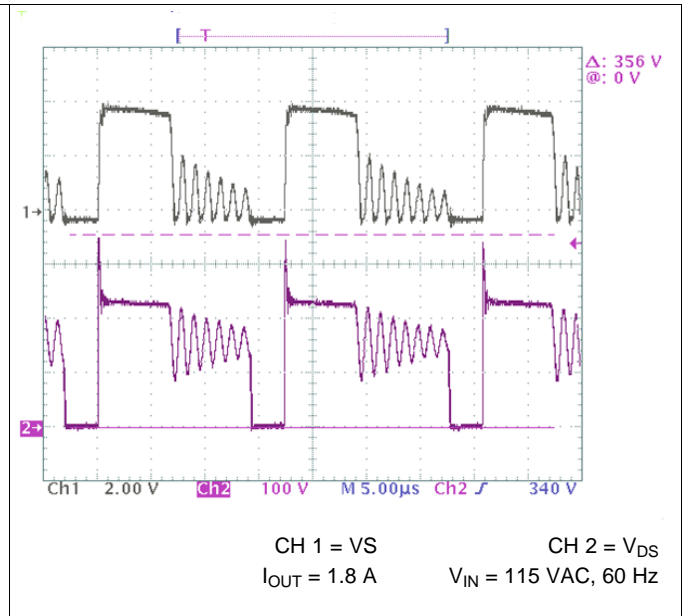

Figure 20. Switching Waveform

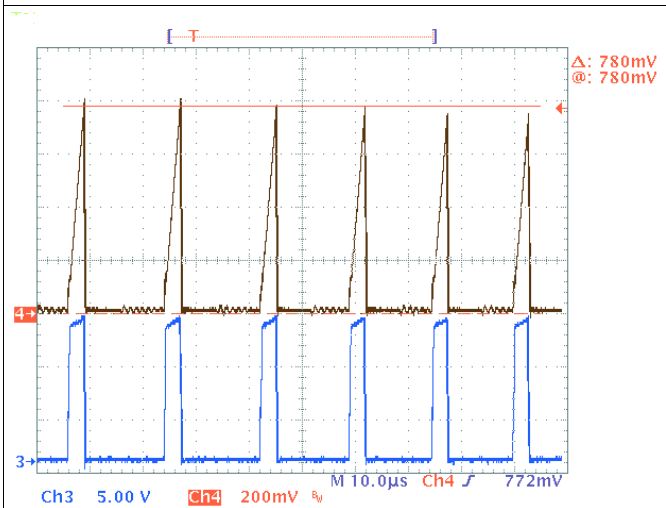

Figure 21. EMI Dithering

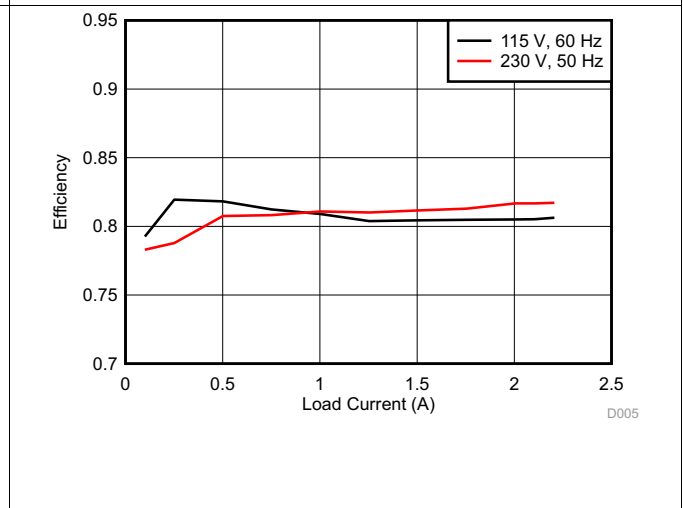

Figure 22. Efficiency

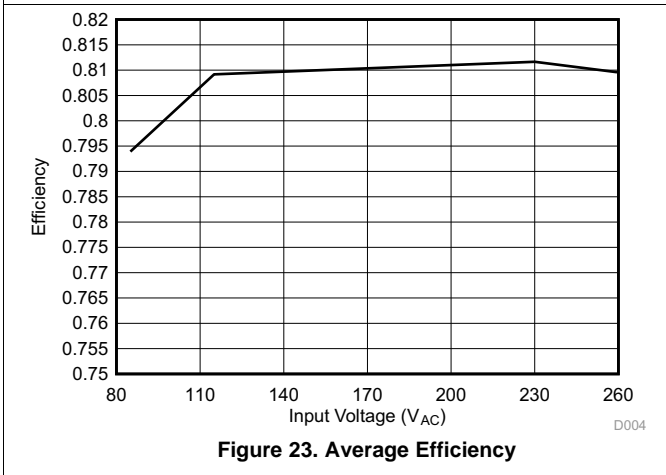

Figure 23. Average Efficiency

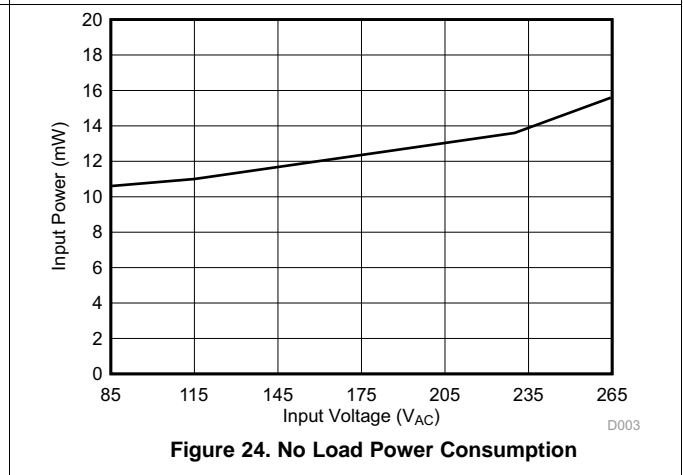

Figure 24. No Load Power Consumption

UCC28740

ZHCSBB1B – JULY 2013 – REVISED DECEMBER 2014

www.ti.com.cn

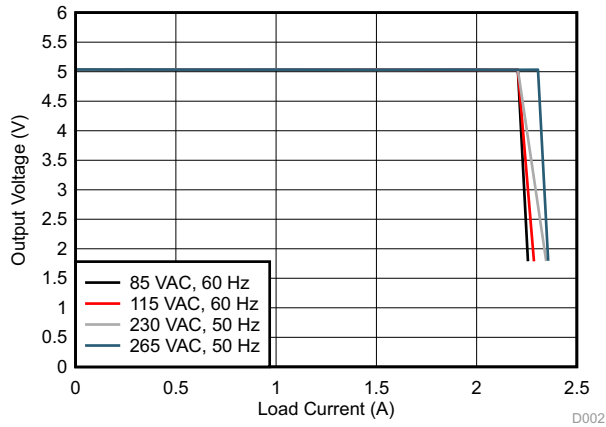

Figure 25. V_{OUT} vs. I_{OUT}

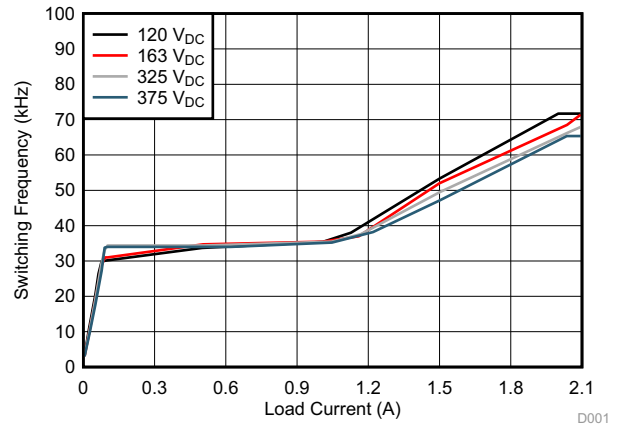
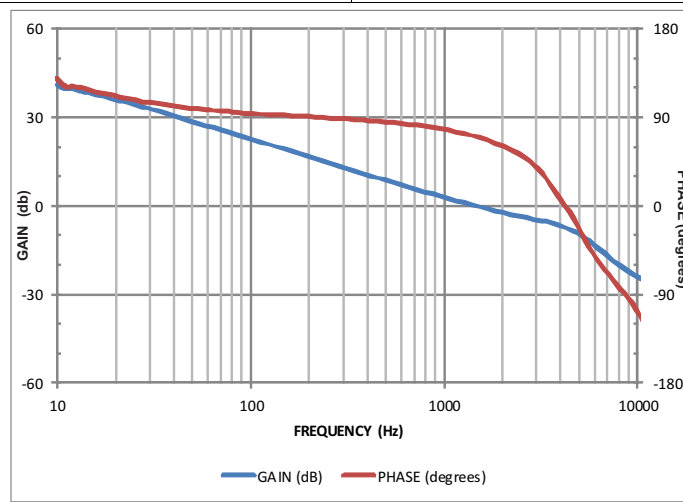

Figure 26. Control Law



$V_{IN} = 115 \text{ VAC}$ $I_{OUT} = 2 \text{ A}$

Figure 27. Bode Plot

9 Power Supply Recommendations

The UCC28740 is designed to be used with a Universal AC input, from 85 VAC to 265 VAC, at 47 Hz to 63 Hz. Other input line conditions can be used provided the HV pin can be set up to provide 500 μ A to charge the VDD capacitor for start-up through the internal startup switch. Once the VDD reaches the 21-V UVLO turnon threshold, the VDD rail should be kept within the limits of the Bias Supply Input section of the [Electrical Characteristics](#) table. To avoid the possibility that the device might stop switching, VDD must not be allowed to fall below the UVLO $V_{VDD(off)}$ range.

10 Layout

10.1 Layout Guidelines

In general, try to keep all high current loops as short as possible. Keep all high current/high frequency traces away from other traces in the design. If necessary, high frequency/high current traces should be perpendicular to signal traces, not parallel to them. Shielding signal traces with ground traces can help reduce noise pick up. Always consider appropriate clearances between the high-voltage connections and any low-voltage nets.

10.1.1 VDD Pin

The VDD pin must be decoupled to GND with good quality, low ESR, low ESL ceramic bypass capacitors with short traces to the VDD and GND pins. The value of the required capacitance on VDD is determined as shown in the [Application and Implementation](#) section.

10.1.2 VS Pin

The trace between the resistor divider and the VS pin should be as short as possible to reduce/eliminate possible EMI coupling. The lower resistor of the resistor divider network connected to the VS pin should be returned to GND with short traces. Avoid adding any external capacitance to the VS pin so that there is no delay of signal; added capacitance would interfere with the accurate sensing of the timing information used to achieve valley switching and also control the duty cycle of the transformer secondary current.

10.1.3 FB Pin

The PCB tracks from the opto-coupler to the FB pin should have minimal loop area. If possible, it is recommended to provide screening for the FB trace with ground planes. A resistor to GND from the FB pin is recommended to speed up the turnoff time of the opto-coupler during a heavy load step transient. This resistor should be placed as close as possible to FB and GND with short traces, the value of this resistor, RFB4, is detailed in the [Application and Implementation](#) section.

10.1.4 GND Pin

The GND pin is the power and signal ground connection for the controller. As with all PWM controllers, the effectiveness of the filter capacitors on the signal pins depends upon the integrity of the ground return. Place all decoupling and filter capacitors as close as possible to the device pins with short traces. The IC ground and power ground should meet at the bulk capacitor's return. Try to ensure that high frequency/high current from the power stage does not go through the signal ground.

10.1.5 CS Pin

A small filter capacitor may be placed on CS to GND, with short traces, to filter any ringing that may be present at light load conditions when driving MOSFETs with large gate capacitance. This capacitor may not be required in all designs; however, it is wise to put a place holder for it in your designs. The current sense resistor should be returned to the ground terminal of the input bulk capacitor to minimize the loop area containing the input capacitor, the transformer, the MOSFET, and the current sense resistor.

10.1.6 DRV Pin

The track connected to DRV carries high dv/dt signals. Minimize noise pickup by routing the trace to this pin as far away as possible from tracks connected to the device signal inputs, FB and VS. There is no requirement for a Gate to Source resistor with this device.

Layout Guidelines (continued)

10.1.7 HV Pin

Sufficient PCB trace spacing must be given between the high-voltage connections and any low-voltage nets. The HV pin may be connected directly, or through series resistance, to the rectified high voltage input rail.

10.2 Layout Example

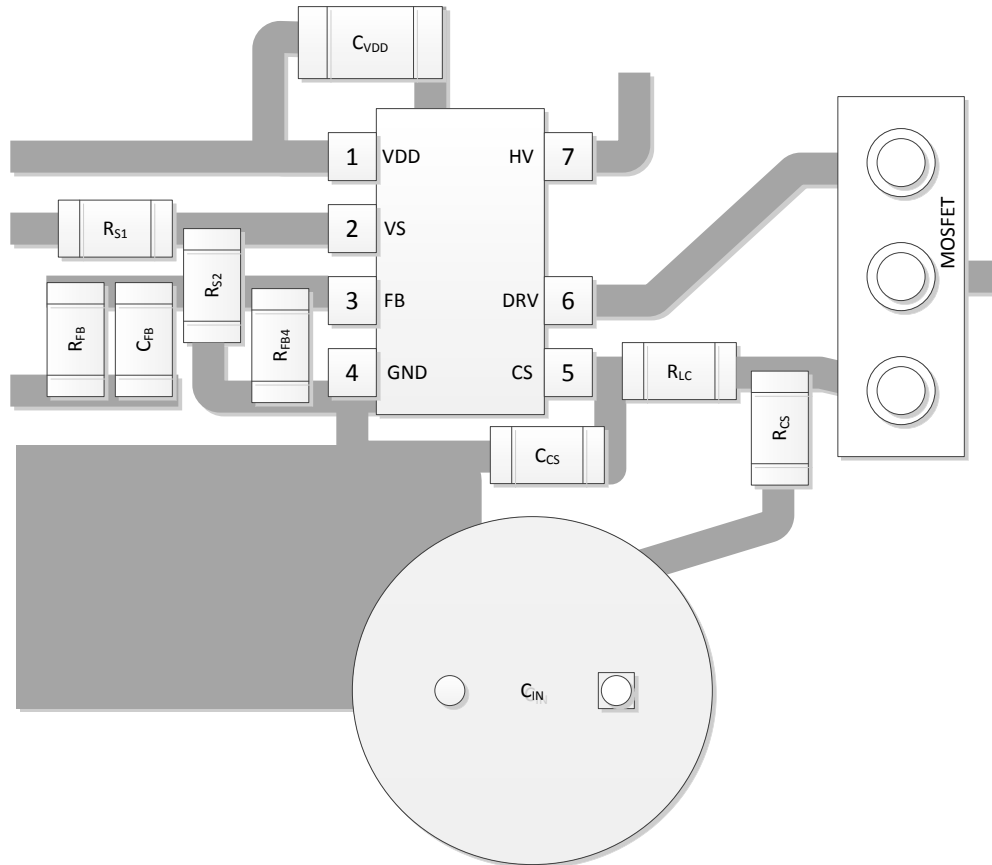

Figure 28. Layout Example Schematic

11 器件和文档支持

11.1 器件支持

11.1.1 术语的定义

11.1.1.1 电容术语（以法拉为单位）

C_{BULK}	C_{B1} 和 C_{B2} 的总输入电容。
C_{VDD}	VDD 引脚所需的最小电容。
C_{OUT}	所需的最小输出电容。

11.1.1.2 占空比术语

D_{MAGCC}	CC 模式中二次侧二极管导通占空比限制，0.425。
D_{MAX}	MOSFET 导通时间占空比。

11.1.1.3 频率术语（以赫兹为单位）

f_{LINE}	最低输入线路频率。
f_{MAX}	转换器的最高目标满载开关频率。
f_{MIN}	转换器的最低稳态开关频率。
$F_{SW(min)}$	最低开关频率（请参见 Electrical Characteristics ）。

11.1.1.4 电流术语（以安培为单位）

I_{OCC}	转换器目标恒流输出值。
$I_{PP(max)}$	变压器一次侧最大峰值电流。
I_{START}	偏置电源启动电流（请参见 Electrical Characteristics ）。
I_{TRAN}	所需的正负载阶跃电流。
$I_{VSL(run)}$	VS 引脚运行电流（请参见 Electrical Characteristics ）。

11.1.1.5 电流和电压调节术语

K_{AM}	一次侧峰峰值电流比（请参见 Electrical Characteristics ）。
K_{LC}	针对线路补偿的电流调节常量（请参见 Electrical Characteristics ）。

11.1.1.6 变压器术语

L_P	变压器一次侧电感。
N_{AS}	变压器辅助绕组与二次侧绕组匝数比。
N_{PA}	变压器一次侧绕组与辅助绕组匝数比。
N_{PS}	变压器一次侧与二次侧绕组匝数比。

11.1.1.7 功率术语（以瓦特为单位）

P_{IN}	转换器最大输入功率。
P_{OUT}	转换器的满载输出功率。
P_{SB}	总待机功率。

11.1.1.8 电阻术语（以 Ω 为单位）

R_{CS}	一次侧峰值电流编程电阻。
----------	--------------

器件支持 (接下页)

R_{ESR}	输出电容的总 ESR。
R_{PL}	转换器输出端的预载电阻。
R_{S1}	高侧 VS 引脚感应电阻。
R_{S2}	低侧 VS 引脚感应电阻。

11.1.1.9 时序术语 (以秒为单位)

t_D	总电流感测延迟 (包括 MOSFET 关断延迟); 在 MOSFET 延迟基础上增加 50ns
$t_{DM(min)}$	二次侧整流器最短导通时间。
$t_{ON(min)}$	MOSFET 最短导通时间。
t_R	DCM 死区内的谐振频率。
t_{RESP}	稳压控制环路对所需最大负载阶跃的最长响应时间。

11.1.1.10 电压术语 (以伏特为单位)

V_{BLK}	用于待机功耗测量的最大大容量电容电压。
$V_{BULK(min)}$	满功率条件下 C_{B1} 和 C_{B2} 的最小谷值电压。
V_{CCR}	恒定电流调节系数 (请参见 Electrical Characteristics)。
$V_{CST(max)}$	CS 引脚最大电流感测阈值 (请参见 Electrical Characteristics)。
$V_{CST(min)}$	CS 引脚最小电流感测阈值 (请参见 Electrical Characteristics)。
$V_{VDD(off)}$	UVLO 关断电压 (请参见 Electrical Characteristics)。
$V_{VDD(on)}$	UVLO 导通电压 (请参见 Electrical Characteristics)。
V_{DSPK}	高压线条件下的 MOSFET 漏源峰值电压。
V_F	电流接近零时的二次侧整流器正向压降。
V_{FA}	辅助整流器正向压降。
V_{LK}	估算的漏感能量复位电压。
$V_{O\Delta}$	CV 模式下负载阶跃瞬态期间允许的输出版降。
V_{OCBC}	添加到 V_{OCV} 的目标电缆补偿电压 (由应用于分流稳压器的外部调节电路提供)。不使用时设为 0V。
V_{OCC}	恒定电流调节状态下的转换器最低输出电压目标值。
V_{OCV}	经稳压的转换器输出电压。
V_{OV}	允许的最大峰值输出电压。
V_{OVP}	VS 输入端的过压检测电压 (请参见 Electrical Characteristics)。
V_{REVA}	辅助整流器的峰值反向电压。
V_{REVS}	二次侧整流器的峰值反向电压。
V_{RIPPLE}	满载条件下的输出峰峰值纹波电压。

11.1.1.11 交流电压术语 (以 V_{RMS} 为单位)

$V_{IN(max)}$	转换器的最大输入电压。
$V_{IN(min)}$	转换器的最小输入电压。
$V_{IN(run)}$	转换器启动 (运行) 输入电压。

器件支持 (接下页)

11.1.1.12 效率术语

η 满功率输出条件下的转换器总体效率。

η_{SB} 无载条件下估算的转换器效率，其中不包括启动电阻或偏置损耗。对于一个 5V USB 充电器应用，60% 到 65% 是一个很好的初步估算值。

η_{XFMR} 变压器一次侧与二次侧之间的功率传输效率。

11.2 商标

All trademarks are the property of their respective owners.

11.3 静电放电警告



这些装置包含有限的内置 ESD 保护。存储或装卸时，应将导线一起截短或将装置放置于导电泡棉中，以防止 MOS 门极遭受静电损伤。

11.4 术语表

[SLYZ022](#) — TI 术语表。

这份术语表列出并解释术语、首字母缩略词和定义。

12 机械、封装和可订购信息

以下页中包括机械、封装和可订购信息。这些信息是针对指定器件可提供的最新数据。这些数据会在无通知且不对本文档进行修订的情况下发生改变。欲获得该数据表的浏览器版本，请查阅左侧的导航栏。

重要声明

德州仪器(TI)及其下属子公司有权根据 JESD46 最新标准,对所提供的产品和服务进行更正、修改、增强、改进或其它更改,并有权根据 JESD48 最新标准中止提供任何产品和服务。客户在下订单前应获取最新的相关信息,并验证这些信息是否完整且是最新的。所有产品的销售都遵循在订单确认时所提供的TI 销售条款与条件。

TI 保证其所销售的组件的性能符合产品销售时 TI 半导体产品销售条件与条款的适用规范。仅在 TI 保证的范围内,且 TI 认为有必要时才会使用测试或其它质量控制技术。除非适用法律做出了硬性规定,否则没有必要对每种组件的所有参数进行测试。

TI 对应用帮助或客户产品设计不承担任何义务。客户应对其使用 TI 组件的产品和应用自行负责。为尽量减小与客户产品和应用相关的风险,客户应提供充分的设计与操作安全措施。

TI 不对任何 TI 专利权、版权、屏蔽作品权或其它与使用了 TI 组件或服务的组合设备、机器或流程相关的 TI 知识产权中授予的直接或隐含权限作出任何保证或解释。TI 所发布的与第三方产品或服务有关的信息,不能构成从 TI 获得使用这些产品或服务的许可、授权、或认可。使用此类信息可能需要获得第三方的专利权或其它知识产权方面的许可,或是 TI 的专利权或其它知识产权方面的许可。

对于 TI 的产品手册或数据表中 TI 信息的重要部分,仅在没有对内容进行任何篡改且带有相关授权、条件、限制和声明的情况下才允许进行复制。TI 对此类篡改过的文件不承担任何责任或义务。复制第三方的信息可能需要服从额外的限制条件。

在转售 TI 组件或服务时,如果对该组件或服务参数的陈述与 TI 标明的参数相比存在差异或虚假成分,则会失去相关 TI 组件或服务的所有明示或暗示授权,且这是不正当的、欺诈性商业行为。TI 对任何此类虚假陈述均不承担任何责任或义务。

客户认可并同意,尽管任何应用相关信息或支持仍可能由 TI 提供,但他们将独立负责满足与其产品及其在应用中使用的 TI 产品相关的所有法律、法规和安全相关要求。客户声明并同意,他们具备制定与实施安全措施所需的全部专业技术和知识,可预见故障的危险后果、监测故障及其后果、降低有可能造成人身伤害的故障的发生机率并采取适当的补救措施。客户将全额赔偿因在此类安全关键应用中使用任何 TI 组件而对 TI 及其代理造成的任何损失。

在某些场合中,为了推进安全相关应用有可能对 TI 组件进行特别的促销。TI 的目标是利用此类组件帮助客户设计和创立其特有的可满足适用的功能安全性标准和要求的终端产品解决方案。尽管如此,此类组件仍然服从这些条款。

TI 组件未获得用于 FDA Class III (或类似的生命攸关医疗设备)的授权许可,除非各方授权官员已经达成了专门管控此类使用的特别协议。

只有那些 TI 特别注明属于军用等级或“增强型塑料”的 TI 组件才是设计或专门用于军事/航空应用或环境的。购买者认可并同意,对并非指定面向军事或航空航天用途的 TI 组件进行军事或航空航天方面的应用,其风险由客户单独承担,并且由客户独立负责满足与此类使用相关的所有法律和法规要求。

TI 已明确指定符合 ISO/TS16949 要求的产品,这些产品主要用于汽车。在任何情况下,因使用非指定产品而无法达到 ISO/TS16949 要求, TI 不承担任何责任。

	产品		应用
数字音频	www.ti.com.cn/audio	通信与电信	www.ti.com.cn/telecom
放大器和线性器件	www.ti.com.cn/amplifiers	计算机及周边	www.ti.com.cn/computer
数据转换器	www.ti.com.cn/dataconverters	消费电子	www.ti.com.cn/consumer-apps
DLP® 产品	www.dlp.com	能源	www.ti.com.cn/energy
DSP - 数字信号处理器	www.ti.com.cn/dsp	工业应用	www.ti.com.cn/industrial
时钟和计时器	www.ti.com.cn/clockandtimers	医疗电子	www.ti.com.cn/medical
接口	www.ti.com.cn/interface	安防应用	www.ti.com.cn/security
逻辑	www.ti.com.cn/logic	汽车电子	www.ti.com.cn/automotive
电源管理	www.ti.com.cn/power	视频和影像	www.ti.com.cn/video
微控制器 (MCU)	www.ti.com.cn/microcontrollers		
RFID 系统	www.ti.com.cn/rfidsys		
OMAP应用处理器	www.ti.com/omap		
无线连通性	www.ti.com.cn/wirelessconnectivity	德州仪器在线技术支持社区	www.deyisupport.com

邮寄地址: 上海市浦东新区世纪大道1568号, 中建大厦32楼邮政编码: 200122
Copyright © 2016, 德州仪器半导体技术(上海)有限公司

PACKAGING INFORMATION

Orderable Device	Status (1)	Package Type	Package Drawing	Pins	Package Qty	Eco Plan (2)	Lead/Ball Finish (6)	MSL Peak Temp (3)	Op Temp (°C)	Device Marking (4/5)	Samples
UCC28740D	ACTIVE	SOIC	D	7	75	Green (RoHS & no Sb/Br)	CU NIPDAU	Level-1-260C-UNLIM	-40 to 125	U28740	Samples
UCC28740DR	ACTIVE	SOIC	D	7	2500	Green (RoHS & no Sb/Br)	CU NIPDAU	Level-1-260C-UNLIM	-40 to 125	U28740	Samples

(1) The marketing status values are defined as follows:

ACTIVE: Product device recommended for new designs.

LIFEBUY: TI has announced that the device will be discontinued, and a lifetime-buy period is in effect.

NRND: Not recommended for new designs. Device is in production to support existing customers, but TI does not recommend using this part in a new design.

PREVIEW: Device has been announced but is not in production. Samples may or may not be available.

OBsolete: TI has discontinued the production of the device.

(2) Eco Plan - The planned eco-friendly classification: Pb-Free (RoHS), Pb-Free (RoHS Exempt), or Green (RoHS & no Sb/Br) - please check <http://www.ti.com/productcontent> for the latest availability information and additional product content details.

TBD: The Pb-Free/Green conversion plan has not been defined.

Pb-Free (RoHS): TI's terms "Lead-Free" or "Pb-Free" mean semiconductor products that are compatible with the current RoHS requirements for all 6 substances, including the requirement that lead not exceed 0.1% by weight in homogeneous materials. Where designed to be soldered at high temperatures, TI Pb-Free products are suitable for use in specified lead-free processes.

Pb-Free (RoHS Exempt): This component has a RoHS exemption for either 1) lead-based flip-chip solder bumps used between the die and package, or 2) lead-based die adhesive used between the die and leadframe. The component is otherwise considered Pb-Free (RoHS compatible) as defined above.

Green (RoHS & no Sb/Br): TI defines "Green" to mean Pb-Free (RoHS compatible), and free of Bromine (Br) and Antimony (Sb) based flame retardants (Br or Sb do not exceed 0.1% by weight in homogeneous material)

(3) MSL, Peak Temp. - The Moisture Sensitivity Level rating according to the JEDEC industry standard classifications, and peak solder temperature.

(4) There may be additional marking, which relates to the logo, the lot trace code information, or the environmental category on the device.

(5) Multiple Device Markings will be inside parentheses. Only one Device Marking contained in parentheses and separated by a "~" will appear on a device. If a line is indented then it is a continuation of the previous line and the two combined represent the entire Device Marking for that device.

(6) Lead/Ball Finish - Orderable Devices may have multiple material finish options. Finish options are separated by a vertical ruled line. Lead/Ball Finish values may wrap to two lines if the finish value exceeds the maximum column width.

Important Information and Disclaimer: The information provided on this page represents TI's knowledge and belief as of the date that it is provided. TI bases its knowledge and belief on information provided by third parties, and makes no representation or warranty as to the accuracy of such information. Efforts are underway to better integrate information from third parties. TI has taken and continues to take reasonable steps to provide representative and accurate information but may not have conducted destructive testing or chemical analysis on incoming materials and chemicals. TI and TI suppliers consider certain information to be proprietary, and thus CAS numbers and other limited information may not be available for release.

In no event shall TI's liability arising out of such information exceed the total purchase price of the TI part(s) at issue in this document sold by TI to Customer on an annual basis.

TAPE AND REEL INFORMATION

QUADRANT ASSIGNMENTS FOR PIN 1 ORIENTATION IN TAPE

*All dimensions are nominal

Device	Package Type	Package Drawing	Pins	SPQ	Reel Diameter (mm)	Reel Width W1 (mm)	A0 (mm)	B0 (mm)	K0 (mm)	P1 (mm)	W (mm)	Pin1 Quadrant
UCC28740DR	SOIC	D	7	2500	330.0	12.4	6.4	5.2	2.1	8.0	12.0	Q1

TAPE AND REEL BOX DIMENSIONS

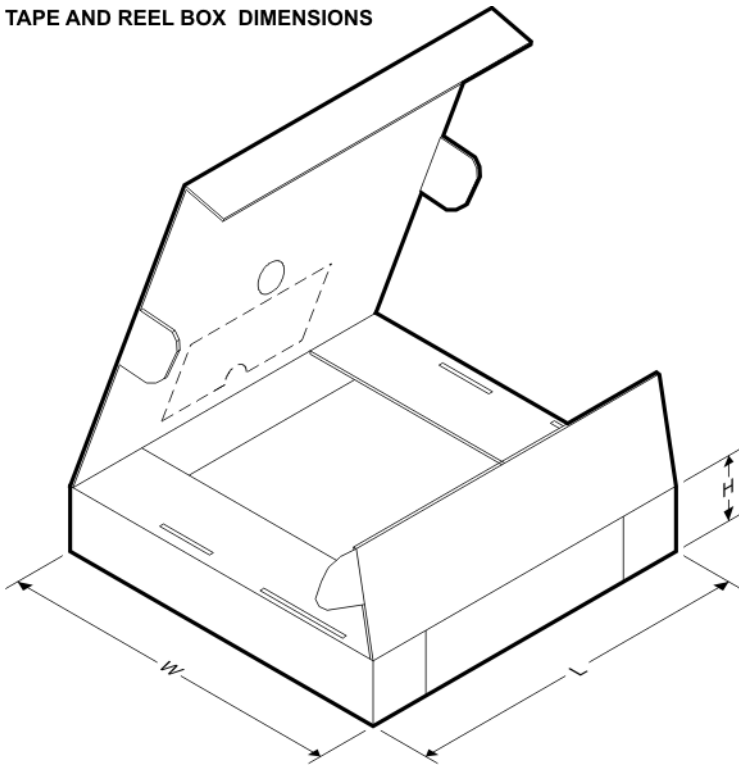

*All dimensions are nominal

Device	Package Type	Package Drawing	Pins	SPQ	Length (mm)	Width (mm)	Height (mm)
UCC28740DR	SOIC	D	7	2500	367.0	367.0	35.0

D (R-PDSO-G7)

PLASTIC SMALL OUTLINE

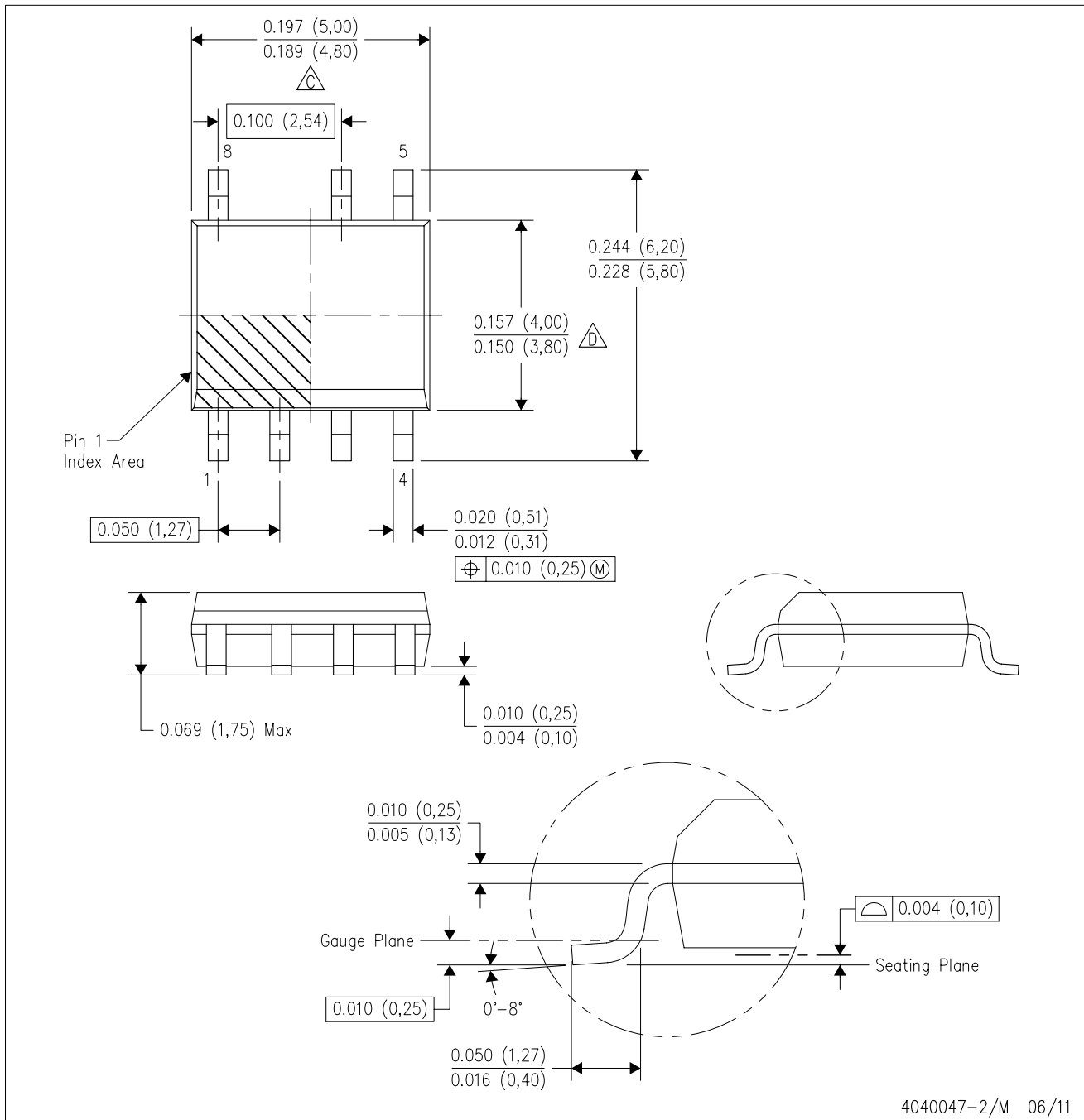

- NOTES:
- A. All linear dimensions are in inches (millimeters).
 - B. This drawing is subject to change without notice.
 - C. Body length does not include mold flash, protrusions, or gate burrs. Mold flash, protrusions, or gate burrs shall not exceed 0.006 (0,15) each side.
 - D. Body width does not include interlead flash. Interlead flash shall not exceed 0.017 (0,43) each side.
 - E. Reference JEDEC MS-012 variation AA.

重要声明

德州仪器(TI) 及其下属子公司有权根据 JESD46 最新标准, 对所提供的产品和服务进行更正、修改、增强、改进或其它更改, 并有权根据 JESD48 最新标准中止提供任何产品和服务。客户在下订单前应获取最新的相关信息, 并验证这些信息是否完整且是最新的。所有产品的销售都遵循在订单确认时所提供的TI 销售条款与条件。

TI 保证其所销售的组件的性能符合产品销售时 TI 半导体产品销售条件与条款的适用规范。仅在 TI 保证的范围内, 且 TI 认为有必要时才会使用测试或其它质量控制技术。除非适用法律做出了硬性规定, 否则没有必要对每种组件的所有参数进行测试。

TI 对应用帮助或客户产品设计不承担任何义务。客户应对其使用 TI 组件的产品和应用自行负责。为尽量减小与客户产品和应用相关的风险, 客户应提供充分的设计与操作安全措施。

TI 不对任何 TI 专利权、版权、屏蔽作品权或其它与使用了 TI 组件或服务的组合设备、机器或流程相关的 TI 知识产权中授予的直接或间接版权限作出任何保证或解释。TI 所发布的与第三方产品或服务有关的信息, 不能构成从 TI 获得使用这些产品或服务的许可、授权、或认可。使用此类信息可能需要获得第三方的专利权或其它知识产权方面的许可, 或是 TI 的专利权或其它知识产权方面的许可。

对于 TI 的产品手册或数据表中 TI 信息的重要部分, 仅在没有对内容进行任何篡改且带有相关授权、条件、限制和声明的情况下才允许进行复制。TI 对此类篡改过的文件不承担任何责任或义务。复制第三方的信息可能需要服从额外的限制条件。

在转售 TI 组件或服务时, 如果对该组件或服务参数的陈述与 TI 标明的参数相比存在差异或虚假成分, 则会失去相关 TI 组件或服务的所有明示或暗示授权, 且这是不正当的、欺诈性商业行为。TI 对任何此类虚假陈述均不承担任何责任或义务。

客户认可并同意, 尽管任何应用相关信息或支持仍可能由 TI 提供, 但他们将独自负责满足与其产品及其应用中使用 TI 产品相关的所有法律、法规和安全相关要求。客户声明并同意, 他们具备制定与实施安全措施所需的全部专业技术和知识, 可预见故障的危险后果、监测故障及其后果、降低有可能造成人身伤害的故障的发生机率并采取适当的补救措施。客户将全额赔偿因在此类安全关键应用中使用任何 TI 组件而对 TI 及其代理造成的任何损失。

在某些场合中, 为了推进安全相关应用有可能对 TI 组件进行特别的促销。TI 的目标是利用此类组件帮助客户设计和创立其特有的可满足适用的功能安全性标准和要求的终端产品解决方案。尽管如此, 此类组件仍然服从这些条款。

TI 组件未获得用于 FDA Class III (或类似的生命攸关医疗设备) 的授权许可, 除非各方授权官员已经达成了专门管控此类使用的特别协议。

只有那些 TI 特别注明属于军用等级或“增强型塑料”的 TI 组件才是设计或专门用于军事/航空应用或环境的。购买者认可并同意, 对并非指定面向军事或航空航天用途的 TI 组件进行军事或航空航天方面的应用, 其风险由客户单独承担, 并且由客户独自负责满足与此类使用相关的所有法律和法规要求。

TI 已明确指定符合 ISO/TS16949 要求的产品, 这些产品主要用于汽车。在任何情况下, 因使用非指定产品而无法达到 ISO/TS16949 要求, TI 不承担任何责任。

	产品		应用
数字音频	www.ti.com.cn/audio	通信与电信	www.ti.com.cn/telecom
放大器和线性器件	www.ti.com.cn/amplifiers	计算机及周边	www.ti.com.cn/computer
数据转换器	www.ti.com.cn/dataconverters	消费电子	www.ti.com.cn/consumer-apps
DLP® 产品	www.dlp.com	能源	www.ti.com.cn/energy
DSP - 数字信号处理器	www.ti.com.cn/dsp	工业应用	www.ti.com.cn/industrial
时钟和计时器	www.ti.com.cn/clockandtimers	医疗电子	www.ti.com.cn/medical
接口	www.ti.com.cn/interface	安防应用	www.ti.com.cn/security
逻辑	www.ti.com.cn/logic	汽车电子	www.ti.com.cn/automotive
电源管理	www.ti.com.cn/power	视频和影像	www.ti.com.cn/video
微控制器 (MCU)	www.ti.com.cn/microcontrollers		
RFID 系统	www.ti.com.cn/rfidsys		
OMAP应用处理器	www.ti.com.cn/omap		
无线连通性	www.ti.com.cn/wirelessconnectivity	德州仪器在线技术支持社区	www.deyisupport.com

Mailing Address: Texas Instruments, Post Office Box 655303, Dallas, Texas 75265
Copyright © 2016, Texas Instruments Incorporated