

# UCC2751x 单通道、高速、低侧栅极驱动器（具有 4A 峰值拉电流和 8A 峰值灌电流）

## 1 特性

- 低成本栅极驱动器器件提供 NPN 和 PNP 离散解决方案的高品质替代产品
- 4A 峰值拉电流和 8A 峰值灌电流非对称驱动
- 强劲的灌电流提供增强的抗米勒接通效应性能
- UCC27511 内部采用分离输出配置（便于单独调整接通和关断速度），节省了一个二极管
- 短暂传播延迟（典型值 13ns）
- 短暂上升和下降时间（典型值分别为 9ns 和 7ns）
- 4.5V 至 18V 单电源范围
- VDD 欠压闭锁 (UVLO) 期间输出保持低电平（确保加电和断电时无毛刺脉冲运行）
- 晶体管逻辑 (TTL) 和互补金属氧化物半导体 (CMOS) 兼容输入逻辑阈值（与电源电压无关）
- 针对高抗扰度的滞后逻辑阈值
- 双输入设计（可选择反相 (IN- 引脚) 或非反相 (IN+ 引脚) 驱动器配置）
  - 未使用的输入引脚可用于使能或禁用功能
- 当输入引脚悬空时，输出保持在低电平
- 输入引脚绝对最大电压电平不受 VDD 引脚偏置电源电压的限制
- -40°C 至 140°C 的运行温度范围
- 6 引脚 DBV (SOT-23) 和 6 引脚 DRS (3mm x 3mm 带有外露散热焊盘的晶圆级小外形无引线 (WSON)) 封装选项

## 2 应用

- 开关模式电源
- DC-DC 转换器
- 用于数字电源控制器的伴随栅极驱动器器件
- 太阳能、电机控制、不间断电源 (UPS)
- 用于新上市的宽带隙电源器件（例如 GaN）的栅极驱动器

## 3 说明

UCC27511 和 UCC27512 单通道高速低侧栅极驱动器器件可有效驱动金属氧化物半导体场效应晶体管 (MOSFET) 和绝缘栅双极型晶体管 (IGBT) 电源开关。UCC27511 和 UCC27512 采用的设计方案可最大程度减少击穿电流，从而为电容负载提供较高的峰值拉/灌电流脉冲，同时提供轨到轨驱动能力以及超短的传播延迟（典型值为 13ns）。

### 器件信息(1)

器件型号	封装	封装尺寸 (标称值)
UCC27511	SOT-23 (6)	2.90mm x 1.60mm
UCC27512	WSON (6)	3.00mm x 3.00mm

(1) 如需了解所有可用封装，请见数据表末尾的可订购产品附录。

### 典型应用图

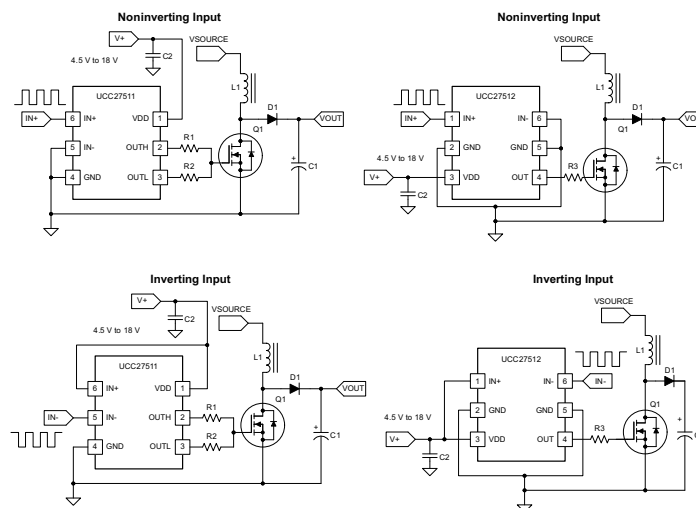

## 目录

1 特性 .....	1	9.1 Overview .....	14
2 应用 .....	1	9.2 Functional Block Diagram .....	14
3 说明 .....	1	9.3 Feature Description .....	15
4 修订历史记录 .....	2	9.4 Device Functional Modes .....	20
5 说明 (续) .....	3	<b>10 Application and Implementation</b> .....	<b>21</b>
6 <b>UCC2751x Product Family</b> .....	<b>3</b>	10.1 Application Information .....	21
7 <b>Pin Configuration and Functions</b> .....	<b>4</b>	10.2 Typical Application .....	21
8 <b>Specifications</b> .....	<b>6</b>	<b>11 Power Supply Recommendations</b> .....	<b>26</b>
8.1 Absolute Maximum Ratings .....	6	<b>12 Layout</b> .....	<b>26</b>
8.2 Handling Ratings .....	6	12.1 Layout Guidelines .....	26
8.3 Recommended Operating Conditions .....	6	12.2 Layout Example .....	27
8.4 Thermal Information .....	7	<b>13 器件和文档支持</b> .....	<b>28</b>
8.5 Electrical Characteristics .....	8	13.1 相关链接 .....	28
8.6 Switching Characteristics .....	9	13.2 商标 .....	28
8.7 Typical Characteristics .....	11	13.3 静电放电警告 .....	28
<b>9 Detailed Description</b> .....	<b>14</b>	13.4 术语表 .....	28
		<b>14 机械、封装和可订购信息</b> .....	<b>28</b>

## 4 修订历史记录

注：之前版本的页码可能与当前版本有所不同。

### Changes from Revision E (December 2013) to Revision F Page

• 已添加 引脚配置和功能部分，处理额定值表，特性 描述 部分，器件功能模式，应用和实施部分，电源相关建议部分，布局部分，器件和文档支持部分以及机械、封装和可订购信息部分 .....	1
---------------------------------------------------------------------------------------------	---

### Changes from Revision D (May 2013) to Revision E Page

• Changed OUTL in the ABS Max Ratings table to show DC and Repetitive pulse values .....	6
------------------------------------------------------------------------------------------	---

### Changes from Revision C (June 2012) to Revision D Page

• 已添加 0.05 to $P_{SW}$ equation in the <i>Power Dissipation</i> section. ....	25
-------------------------------------------------------------------------------	----

### Changes from Revision B (March, 2012) to Revision C Page

• 已添加 UCC27512 器件 (通篇) .....	1
• 已添加 6 引脚 DRS 封装特性 .....	1
• Added DRS pinout for the UCC27512 .....	4
• Added UCC27512 TERMINAL FUNCTIONS table .....	5
• Added OUT voltage ab max ratings for the UCC27512 .....	6
• Added <sup>(1)</sup> .....	6
• Changed ESD ratings of Human Body Model, HBM from 2000 V to 4000 V .....	6
• Changed ESD ratings of Charged Device Model, CDM SOT-23 from 500 V to 1000 V .....	6
• Added UCC27512 Thermal Information .....	7
• 已添加 power dissipation conditions note to Thermal Information section .....	7
• 已添加 UCC27512 Functional Block Diagram .....	15
• 已添加 UCC27512 application diagrams .....	21
• 已添加 Typical Application Diagram note .....	22

(1) Values are verified by characterization on bench.

---

- 已添加 PCB layout bullet ..... [27](#)

---

## 5 说明（续）

UCC27511 特有 双输入设计，同一器件可灵活实现反相（IN- 引脚）和非反相（IN+ 引脚）配置。IN+ 引脚和 IN- 引脚均可用于控制驱动器输出的状态。未使用的输入引脚可用于启用和禁用功能。出于安全考虑，输入引脚上的内部上拉和下拉电阻器在输入引脚处于悬空状态时，确保输出被保持在低电平。因此，未使用的输入引脚不能保持在悬空状态，而需要被适当的偏置以确保驱动器输出被启用用于正常运行。

UCC27511 器件的输入引脚阈值基于与 TTL 和 COMS 兼容的低电压逻辑电路，此逻辑电路是固定的且与  $V_{DD}$  电源电压无关。高低阈值间的宽滞后提供了出色的抗扰度。

UCC27511 和 UCC27512 提供 4A 拉电流，8A 灌电流（非对称驱动）峰值驱动电流能力。非对称驱动中的强劲灌电流能力提升了抗寄生、米勒接通效应的能力。UCC27511 器件还具有一个独特的分离输出配置，其中的栅极驱动电流通过 OUTH 引脚拉出，通过 OUTL 引脚灌入。这种独特的引脚排列使得用户能够分别在 OUTH 和 OUTL 引脚上使用独立的接通和关断电阻，并且能轻松控制开关转换率。

UCC27511 和 UCC27512 具有 4.5V 至 18V 的宽  $V_{DD}$  范围，以及  $-40^{\circ}\text{C}$  至  $140^{\circ}\text{C}$  的宽温度范围。 $V_{DD}$  引脚上的内部欠压锁定 (UVLO) 电路可在超出  $V_{DD}$  运行范围时使输出保持低电平。此器件能够在低电压（例如低于 5V）下运行，并且拥有同类产品中较好的开关特性，因此非常适用于驱动诸如 GaN 功率半导体器件等新上市的宽带隙电源开关器件。

## 6 UCC2751x Product Family

The UCC2751x family of gate-driver products (Table 1) represent Texas Instruments' latest generation of single-channel low-side high-speed gate-driver devices featuring high-source/sink current capability, industry best-in-class switching characteristics and a host of other features (Table 2) all of which combine to ensure efficient, robust and reliable operation in high-frequency switching power circuits.

**Table 1. UCC2751x Product Family Summary**

PART NUMBER	PACKAGE	PEAK CURRENT (SOURCE/SINK)	INPUT THRESHOLD LOGIC
UCC27511DBV	SOT-23, 6 pin	4-A/8-A (Asymmetrical Drive)	CMOS/TTL-Compatible (low voltage, independent of VDD bias voltage)
UCC27512DRS	3-mm x 3-mm WSON, 6 pin		
UCC27516DRS <sup>(1)</sup>	3-mm x 3-mm WSON, 6 pin	4-A/4-A (Symmetrical Drive)	CMOS (follows VDD bias voltage)
UCC27517DBV <sup>(1)</sup>	SOT-23, 5 pin		
UCC27518DBV <sup>(1)</sup>	SOT-23, 5 pin		
UCC27519DBV <sup>(1)</sup>	SOT-23, 5 pin		

(1) Visit [www.ti.com](http://www.ti.com) for the latest product datasheet.

**Table 2. UCC2751x Features and Benefits**

FEATURE	BENEFIT
High Source and Sink Current Capability 4 A and 8 A (Asymmetrical) – UCC2751/6/7/8/9 4 A and 4 A (Symmetrical) – UCC27511 and UCC27512	High current capability offers flexibility in employing UCC2751x family of devices to drive a variety of power switching devices at varying speeds
Best-in-class 13-ns (typ) Propagation delay	Extremely low pulse-transmission distortion
Expanded VDD Operating range of 4.5 V to 18 V	Flexibility in system design
Expanded Operating Temperature range of $-40^{\circ}\text{C}$ to $140^{\circ}\text{C}$ (See <a href="#">Electrical Characteristics</a> table)	Low VDD operation ensures compatibility with emerging wide band-gap power devices such as GaN
VDD UVLO Protection	Outputs are held low in UVLO condition, which ensures predictable glitch-free operation at power up and power down
Outputs held low when input pins (INx) in floating condition	Safety feature, especially useful in passing abnormal condition tests during safety certification
Ability of input pins (and enable pin in UCC27518/9) to handle voltage levels not restricted by VDD pin bias voltage	System simplification, especially related to auxiliary bias supply architecture
Split output structure in UCC27511 (OUTH, OUTL)	Allows independent optimization of turnon and turnoff speeds

**Table 2. UCC2751x Features and Benefits (continued)**

FEATURE	BENEFIT
Strong sink current (8 A) and low pulldown impedance (0.375 Ω) in UCC27511 and UCC27512	High immunity to C x dV/dt Miller turnon events
CMOS/TTL compatible input-threshold logic with wide hysteresis in UCC27511, UCC27512, UCC27516 and UCC27517	Enhanced noise immunity, while retaining compatibility with microcontroller logic-level input signals (3.3 V, 5 V) optimized for digital power
CMOS input threshold logic in UCC27518/9 (VIN_H – 70% VDD, VIN_L – 30% VDD)	Well suited for slow input-voltage signals, with flexibility to program delay circuits (RCD)

## 7 Pin Configuration and Functions

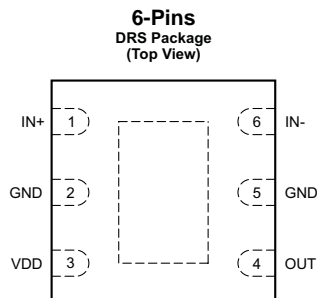
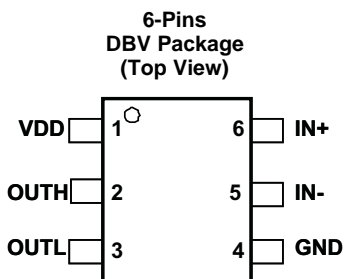

**Pin Functions - UCC27511**

PIN		I/O	DESCRIPTION
NO.	NAME		
1	VDD	I	<b>Bias supply input.</b>
2	OUTH	O	<b>Sourcing current output of driver.</b> Connect resistor between OUTH and Gate of power-switching device to adjust turnon speed.
3	OUTL	O	<b>Sinking current output of driver.</b> Connect resistor between OUTL and Gate of power-switching device to adjust turnoff speed.
4	GND	-	<b>Ground:</b> All signals referenced to this pin.
5	IN-	I	<b>Inverting input:</b> When the driver is used in noninverting configuration, connect IN- to GND in order to enable output, OUT held LOW if IN- is unbiased or floating
6	IN+	I	<b>Noninverting input:</b> When the driver is used in inverting configuration, connect IN+ to VDD in order to enable output, OUT held LOW if IN+ is unbiased or floating

**Pin Functions - UCC27512**

PIN		I/O	DESCRIPTION
NO.	NAME		
1	IN+	I	<b>Noninverting input:</b> When the driver is used in inverting configuration, connect IN+ to VDD in order to enable output, OUT held LOW if IN+ is unbiased or floating.
2, 5	GND	-	<b>Ground:</b> All signals referenced to this pin. TI recommends to connect pin 2 and pin 5 on PCB as close to the device as possible.
3	VDD	I	<b>Bias supply input.</b>
4	OUT	O	<b>Sourcing/sinking current output of driver.</b>
6	IN-	I	<b>Inverting input:</b> When the driver is used in noninverting configuration, connect IN- to GND in order to enable output, OUT held LOW if IN- is unbiased or floating.

## 8 Specifications

### 8.1 Absolute Maximum Ratings<sup>(1)(2)(3)</sup>

over operating free-air temperature range (unless otherwise noted)

		MIN	MAX	UNIT
Supply voltage range	VDD	−0.3	20	V
OUTH voltage, (UCC27511)		−0.3	VDD + 0.3	
OUTL voltage, (UCC27511)	DC	−0.3	20	
	Repetitive pulse less than 200 ns <sup>(4)</sup>	−2	20	
OUT voltage, (UCC27512)	DC	−0.3	VDD + 0.3	
	Repetitive pulse less than 200 ns <sup>(4)</sup>	−2	VDD + 0.3	
Output continuous current (OUTH source current and OUTL sink current)	I <sub>OUT_DC</sub> (source)		0.3	A
	I <sub>OUT_DC</sub> (sink)		0.6	
Output pulsed current (0.5 μs) (OUTH source current and OUTL sink current)	I <sub>OUT_pulsed</sub> (source)		4	
	I <sub>OUT_pulsed</sub> (sink)		8	
IN+, IN <sup>−</sup> <sup>(5)</sup>		−0.3	20	V
Lead temperature	Soldering, 10 sec.		300	°C
	Reflow		260	

- (1) Stresses beyond those listed under Absolute Maximum Ratings may cause permanent damage to the device. These are stress ratings only and functional operation of the device at these or any other conditions beyond those indicated under [Recommended Operating Conditions](#) is not implied. Exposure to absolute-maximum-rated conditions for extended periods may affect device reliability.
- (2) All voltages are with respect to GND unless otherwise noted. Currents are positive into and negative out of the specified terminal. See Packaging Section of the datasheet for thermal limitations and considerations of packages.
- (3) These devices are sensitive to electrostatic discharge; follow proper device handling procedures.
- (4) Values are verified by characterization on bench.
- (5) Maximum voltage on input pins is not restricted by the voltage on the VDD pin.

### 8.2 Handling Ratings

			MIN	MAX	UNIT
T <sub>stg</sub>	Storage temperature range		−65	150	°C
V <sub>(ESD)</sub>	Electrostatic discharge	Human body model (HBM), per ANSI/ESDA/JEDEC JS-001, all pins <sup>(1)</sup>	−4000	4000	V
		Charged device model (CDM), per JEDEC specification JESD22-C101, all pins <sup>(2)</sup>	−1000	1000	

- (1) JEDEC document JEP155 states that 500-V HBM allows safe manufacturing with a standard ESD control process.
- (2) JEDEC document JEP157 states that 250-V CDM allows safe manufacturing with a standard ESD control process.

### 8.3 Recommended Operating Conditions

over operating free-air temperature range (unless otherwise noted)

				MIN	TYP	MAX	UNIT
Supply voltage range, VDD				4.5	12	18	V
Operating junction temperature range				−40		140	°C
Input voltage, IN+ and IN-				0		18	V

## 8.4 Thermal Information

THERMAL METRIC		UCC27511	UCC27512	UNIT
		DBV	WSON <sup>(1)</sup>	
		6 PINS	6 PINS	
$\theta_{JA}$	Junction-to-ambient thermal resistance <sup>(2)</sup>	217.8	85.6	°C/W
$\theta_{JCtop}$	Junction-to-case (top) thermal resistance <sup>(3)</sup>	97.6	100.1	
$\theta_{JB}$	Junction-to-board thermal resistance <sup>(4)</sup>	72.2	58.6	
$\psi_{JT}$	Junction-to-top characterization parameter <sup>(5)</sup>	8.6	7.5	
$\psi_{JB}$	Junction-to-board characterization parameter <sup>(6)</sup>	71.6	58.7	
$\theta_{Jcbot}$	Junction-to-case (bottom) thermal resistance <sup>(7)</sup>	n/a	23.7	

- (1) For more information about traditional and new thermal metrics, see the *IC Package Thermal Metrics* application report, [SPRA953](#).
- (2) The junction-to-ambient thermal resistance under natural convection is obtained in a simulation on a JEDEC-standard, high-K board, as specified in JESD51-7, in an environment described in JESD51-2a.
- (3) The junction-to-case (top) thermal resistance is obtained by simulating a cold plate test on the package top. No specific JEDEC-standard test exists, but a close description can be found in the ANSI SEMI standard G30-88.
- (4) The junction-to-board thermal resistance is obtained by simulating in an environment with a ring cold plate fixture to control the PCB temperature, as described in JESD51-8.
- (5) The junction-to-top characterization parameter,  $\psi_{JT}$ , estimates the junction temperature of a device in a real system and is extracted from the simulation data for obtaining  $R_{\theta JA}$ , using a procedure described in JESD51-2a (sections 6 and 7).
- (6) The junction-to-board characterization parameter,  $\psi_{JB}$ , estimates the junction temperature of a device in a real system and is extracted from the simulation data for obtaining  $R_{\theta JA}$ , using a procedure described in JESD51-2a (sections 6 and 7).
- (7) The junction-to-case (bottom) thermal resistance is obtained by simulating a cold plate test on the exposed (power) pad. No specific JEDEC standard test exists, but a close description can be found in the ANSI SEMI standard G30-88.

### 注

Under identical power dissipation conditions, the DRS package will allow to maintain a lower die temperature than the DBV.  $\theta_{JA}$  metric should be used for comparison of power dissipation capability between different packages (Refer to the [Power Dissipation](#) Section).

## 8.5 Electrical Characteristics

$V_{DD} = 12\text{ V}$ ,  $T_A = T_J = -40^\circ\text{C}$  to  $140^\circ\text{C}$ ,  $1\text{-}\mu\text{F}$  capacitor from  $V_{DD}$  to GND. Currents are positive into, negative out of the specified terminal.

PARAMETER		TEST CONDITION	MIN	TYP	MAX	UNIT		
<b>BIAS CURRENTS</b>								
$I_{DD(\text{off})}$	Startup current	$V_{DD} = 3.4\text{ V}$	IN+ = VDD, IN- = GND		40	100	160	$\mu\text{A}$
			IN+ = IN- = GND or IN+ = IN- = VDD		25	75	145	
			IN+ = GND, IN- = VDD		20	60	115	
<b>UNDERVOLTAGE LOCKOUT (UVLO)</b>								
$V_{ON}$	Supply start threshold	$T_A = 25^\circ\text{C}$	3.91	4.20	4.5	V		
		$T_A = -40^\circ\text{C}$ to $140^\circ\text{C}$	3.70	4.20	4.65			
$V_{OFF}$	Minimum operating voltage after supply start		3.45	3.9	4.35			
$V_{DD\_H}$	Supply voltage hysteresis		0.2	0.3	0.5			
<b>INPUTS (IN+, IN-)</b>								
$V_{IN\_H}$	Input signal high threshold	Output high for IN+ pin, Output low for IN- pin		2.2	2.4	V		
$V_{IN\_L}$	Input signal low threshold	Output low for IN+ pin, Output high for IN- pin	1.0	1.2				
$V_{IN\_HYS}$	Input signal hysteresis			1.0				
<b>SOURCE/SINK CURRENT</b>								
$I_{SRC/SNK}$	Source/sink peak current <sup>(1)</sup>	$C_{LOAD} = 0.22\text{ }\mu\text{F}$ , $F_{SW} = 1\text{ kHz}$		-4/+8		A		
<b>OUTPUTS (OUTH, OUTL, OUT)</b>								
$V_{DD-}$ $V_{OH}$	High output voltage	$V_{DD} = 12\text{ V}$ $I_{OUTH} = -10\text{ mA}$		50	90	mV		
		$V_{DD} = 4.5\text{ V}$ $I_{OUTH} = -10\text{ mA}$		60	130			
$V_{OL}$	Low output voltage	$V_{DD} = 12\text{ V}$ $I_{OUTL} = 10\text{ mA}$		5	6.5			
		$V_{DD} = 4.5\text{ V}$ $I_{OUTL} = 10\text{ mA}$		5.5	10			
$R_{OH}$	Output pull-up resistance <sup>(2)</sup>	$V_{DD} = 12\text{ V}$ $I_{OUTH} = -10\text{ mA}$		5.0	7.5	$\Omega$		
		$V_{DD} = 4.5\text{ V}$ $I_{OUTH} = -10\text{ mA}$		5.0	11.0			
$R_{OL}$	Output pull-down resistance	$V_{DD} = 12\text{ V}$ $I_{OUTL} = 10\text{ mA}$		0.375	0.650			
		$V_{DD} = 4.5\text{ V}$ $I_{OUTL} = 10\text{ mA}$		0.45	0.750			

(1) Ensured by Design.

(2)  $R_{OH}$  represents on-resistance of P-Channel MOSFET in pullup structure of the output stage of the UCC27511 and UCC27512.

### 8.6 Switching Characteristics

over operating free-air temperature range (unless otherwise noted)

PARAMETER	TEST CONDITIONS	MIN	TYP	MAX	UNIT	
$t_R$	Rise time <sup>(1)</sup>	VDD = 12 V C <sub>LOAD</sub> = 1.8 nF, connected to OUTH and OUTL pins tied together		8	12	ns
		VDD = 4.5 V C <sub>LOAD</sub> = 1.8 nF		16	22	
$t_F$	Fall time <sup>(1)</sup>	VDD = 12 V C <sub>LOAD</sub> = 1.8 nF, connected to OUTH and OUTL pins tied together		7	11	
		VDD=4.5V C <sub>LOAD</sub> = 1.8 nF		7	11	
$t_{D1}$	IN+ to output propagation delay <sup>(1)</sup>	VDD = 12 V 5-V input pulse C <sub>LOAD</sub> = 1.8 nF, connected to OUTH and OUTL pins tied together	4	13	23	
		VDD = 4.5 V 5-V input pulse C <sub>LOAD</sub> = 1.8 nF, connected to OUTH and OUTL pins tied together	4	15	26	
$t_{D2}$	IN- to output propagation delay <sup>(1)</sup>	VDD = 12 V C <sub>LOAD</sub> = 1.8 nF, connected to OUTH and OUTL pins tied together	4	13	23	
		VDD = 4.5 V C <sub>LOAD</sub> = 1.8 nF, connected to OUTH and OUTL pins tied together	4	19	30	

(1) See timing diagrams in 图 1, 图 2, 图 3 and 图 4.

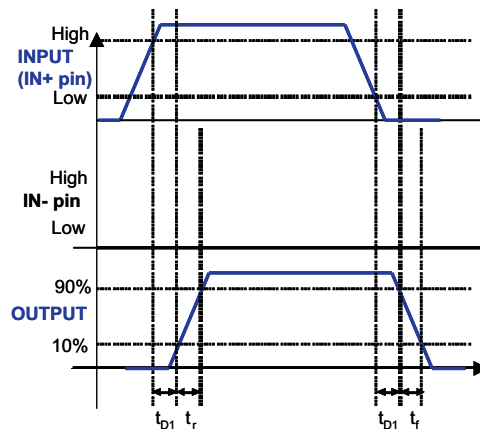

(PWM Input to IN+ Pin (IN- Pin Tied to GND), Output Represents OUTH And OUTL Pins Tied Together in the UCC27511)

图 1. Noninverting Configuration

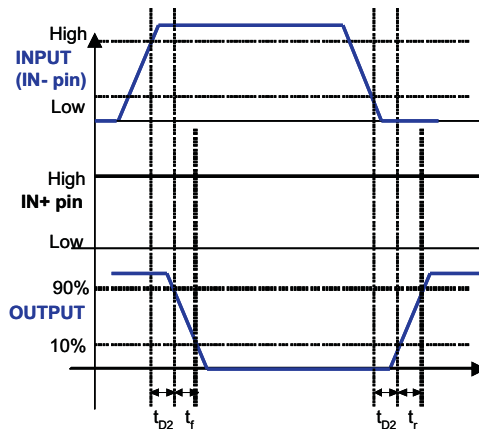

(PWM Input to IN- Pin (IN+ Pin Tied to VDD), Output Represents OUTH and OUTL Pins Tied Together in the UCC27511)

图 2. Inverting Configuration

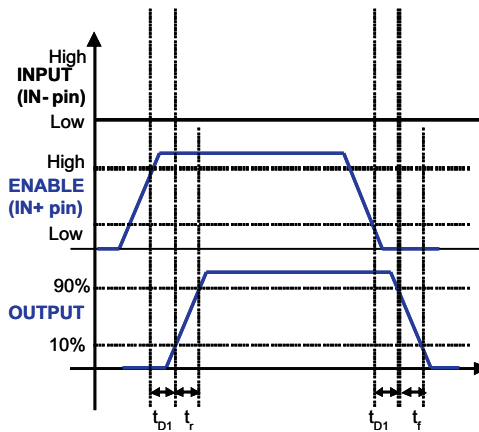

(Enable and Disable Signal Applied to IN+ Pin, PWM Input to IN- Pin, Output Represents OUTH and OUTL Pins Tied Together in the UCC27511)

图 3. Enable and Disable Function Using IN+ Pin

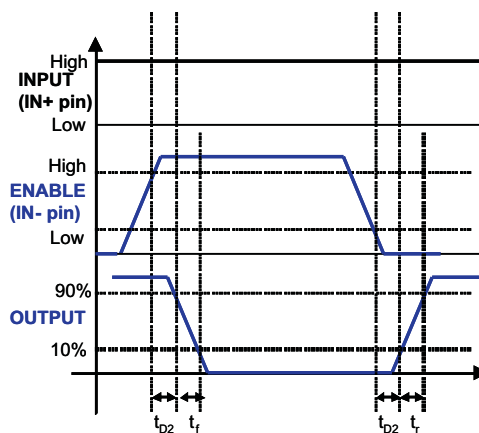

(Enable and Disable Signal Applied to IN- Pin, PWM Input To IN+ Pin, Output Represents OUTH and OUTL Pins Tied Together in the UCC27511)

图 4. Enable and Disable Function Using IN- Pin

### 8.7 Typical Characteristics

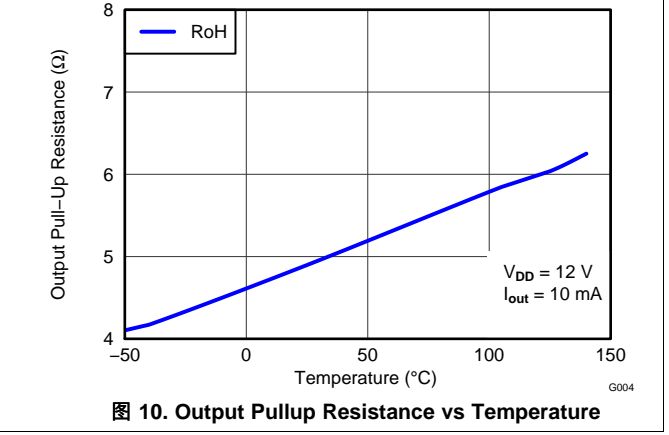
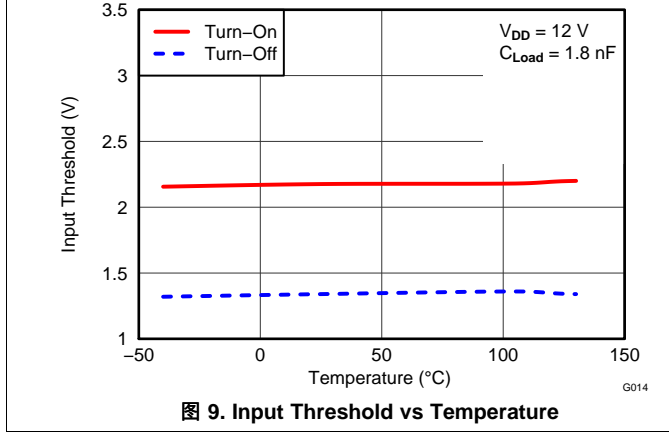
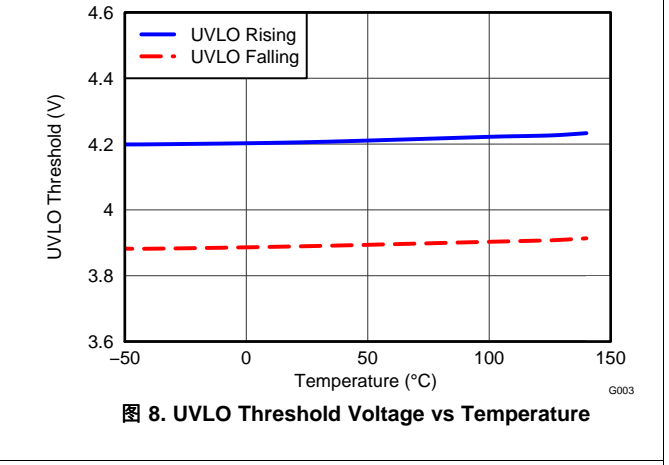
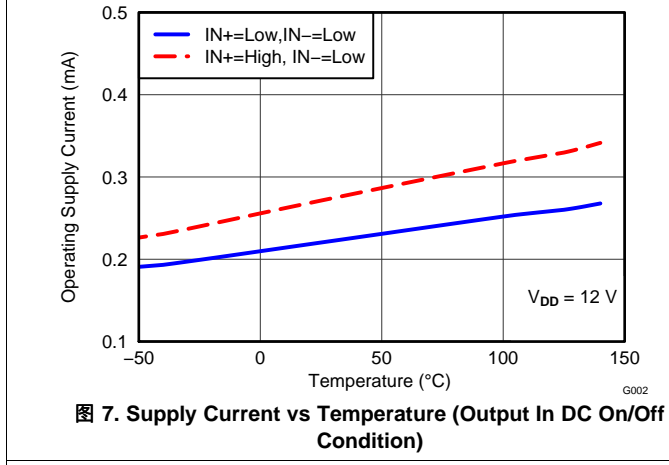
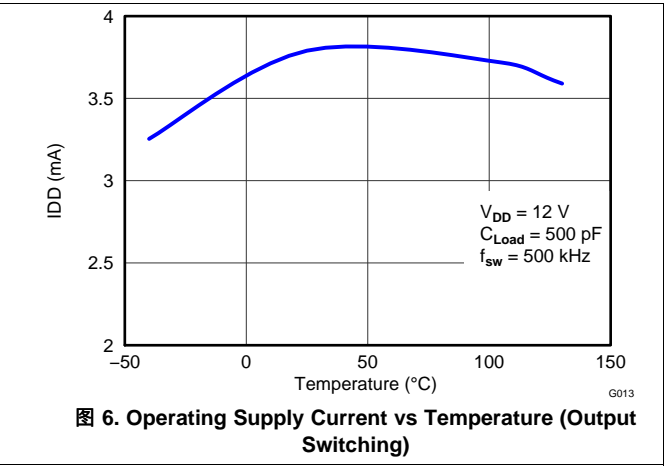
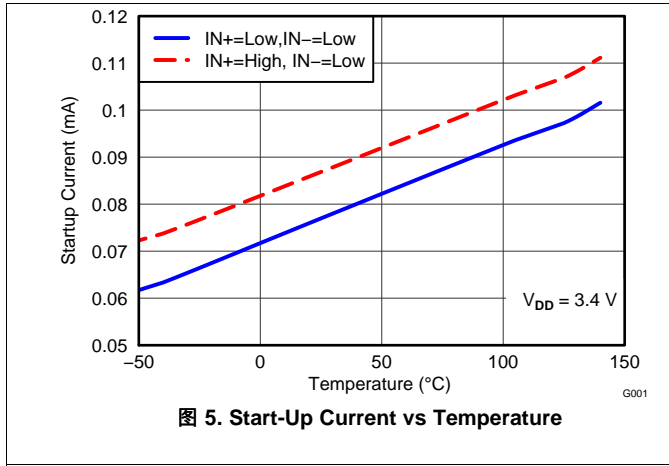

Typical Characteristics (接下页)



图 11. Output Pulldown Resistance vs Temperature



图 12. Rise Time vs Temperature

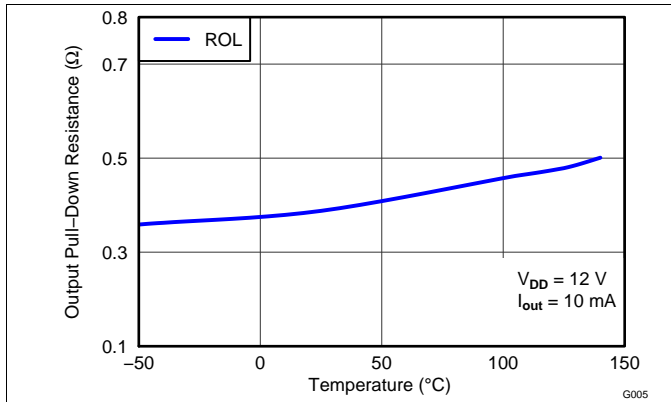

图 13. Fall Time vs Temperature

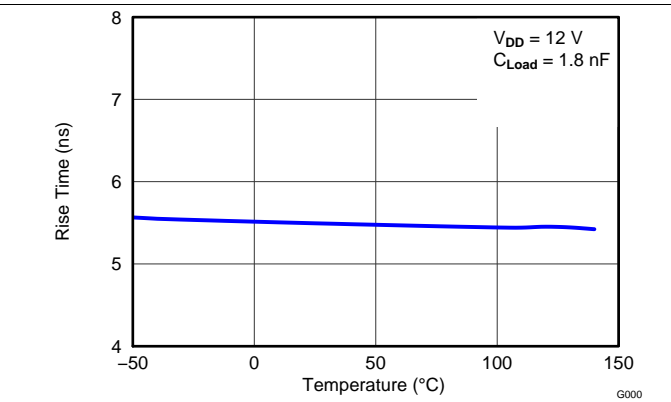

图 14. Input to Output Propagation Delay vs Temperature

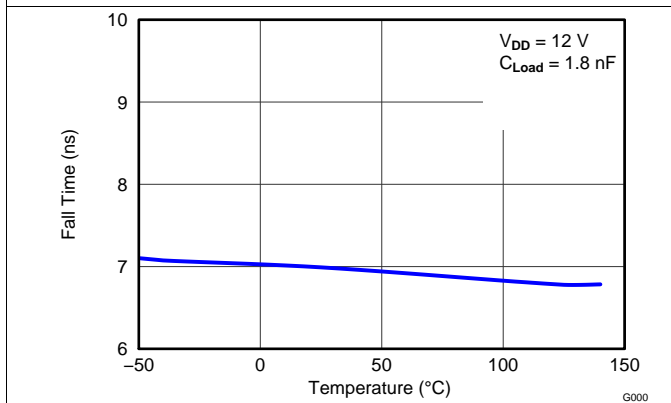

图 15. Operating Supply Current vs Frequency

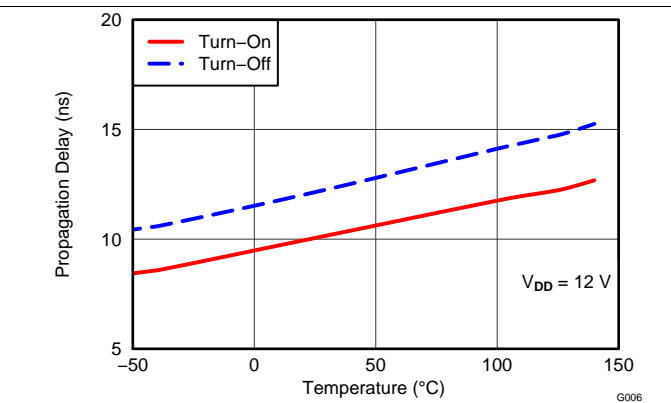

图 16. Propagation Delays vs Supply Voltage

**Typical Characteristics (接下页)**

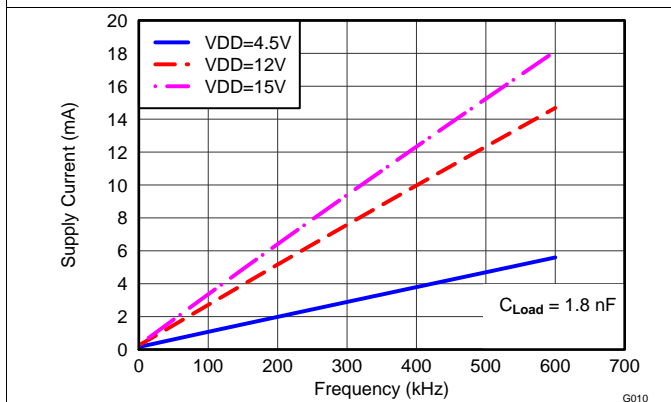

## 9 Detailed Description

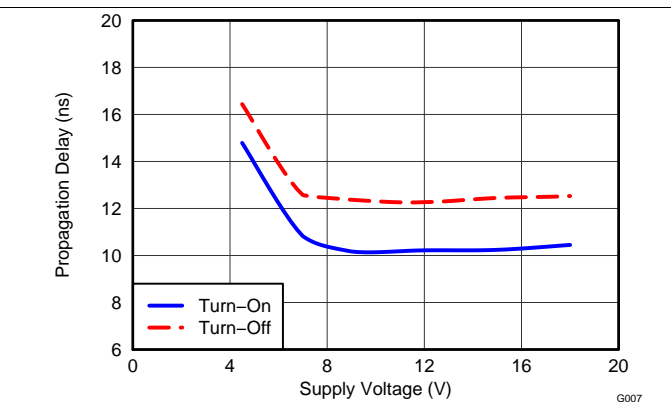
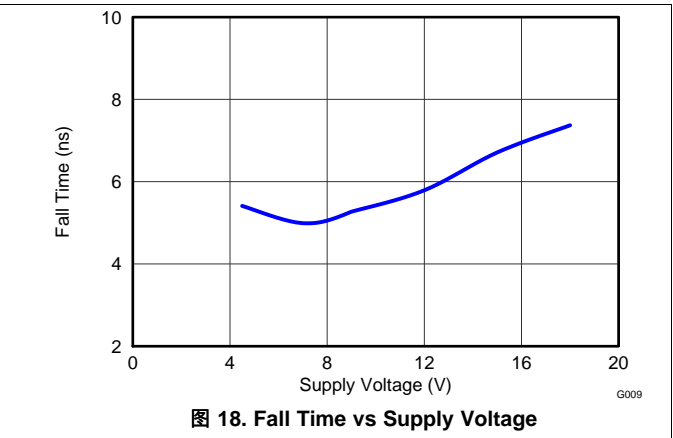
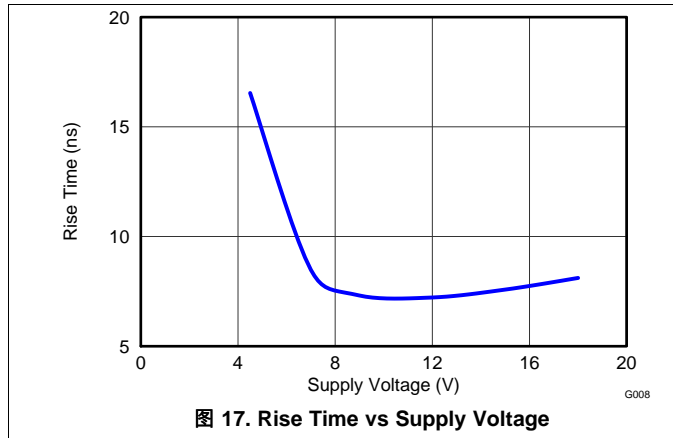
### 9.1 Overview

The UCC27511/2 single-channel high-speed low-side gate-driver device is capable of effectively driving MOSFET and IGBT power switches. Using a design that inherently minimizes shoot-through current, the UCC27511 device is capable of sourcing and sinking high peak-current pulses into capacitive loads offering rail-to-rail drive capability and extremely small propagation delay of 13 ns (typical).

The UCC27511 device provides 4-A source, 8-A sink (asymmetrical drive) peak-drive current capability. Strong sink capability in asymmetrical drive boosts immunity against parasitic, Miller turnon effect. The UCC27511 device also features a unique split output configuration where the gate-drive current is sourced through the OUTH pin and sunk through the OUTL pin. This unique pin arrangement allows the user to apply independent turnon and turnoff resistors to the OUTH and OUTL pins (respectively) and easily control the switching slew rates.

Alternatively the OUTH and OUTL pins can be tied together, which results in a typical gate driver output configuration where the source and sink currents are delivered from the same pin. In case of UCC27511 device, the state of the device's output is simply determined by the combined states of the OUTH and OUTL pins when tied together. Output high implies that OUTH pin is pulled close to  $V_{DD}$  pin bias voltage while OUTL pin is in high-impedance state. Similarly output low implies that OUTL pin is pulled close to the GND pin while OUTH pin is in high-impedance state. OUTH pulled to VDD, while OUTL pulled to GND pin simultaneously is not a valid state for the device.

The UCC27511 device is designed to operate over a wide  $V_{DD}$  range of 4.5 to 18 V and wide temperature range of  $-40^{\circ}\text{C}$  to  $140^{\circ}\text{C}$ . Internal undervoltage lockout (UVLO) circuitry on the  $V_{DD}$  pin holds the output low outside  $V_{DD}$  operating range. The capability to operate at low voltage levels, such as below 5 V, along with best-in-class switching characteristics, is especially suited for driving emerging wide band-gap power-switching devices such as GaN power-semiconductor devices.

The UCC27511 device features a dual-input design which offers flexibility of implementing both inverting (IN– pin) and noninverting (IN+ pin) configuration with the same device. Either the IN+ or IN– pin can be used to control the state of the driver output. The unused input pin can be used for enable and disable functions. For system robustness, internal pullup and pulldown resistors on the input pins ensure that outputs are held low when the input pins are in floating condition. Therefore the unused input pin is not left floating and must be properly biased to ensure that driver output is in enabled for normal operation.

The input pin threshold of the UCC27511A-Q1 device is based on TTL and CMOS-compatible low-voltage logic which is fixed and independent of the  $V_{DD}$  supply voltage. Wide hysteresis between the high and low thresholds offers excellent noise immunity.

### 9.2 Functional Block Diagram



图 19. UCC27511 Functional Block Diagram

Functional Block Diagram (接下页)

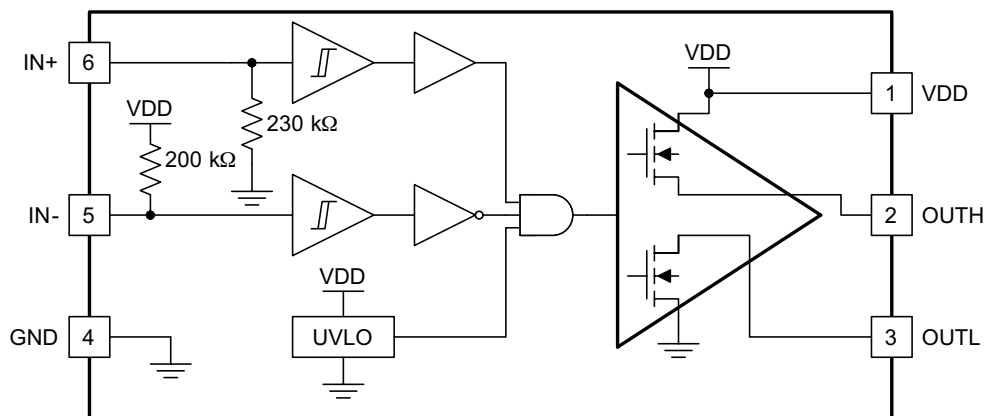

图 20. UCC27512 Functional Block Diagram

9.3 Feature Description

In the following sections with respect to UCC27511, the term *output*, or *OUT* refers to the combined state that results when the OUTH pin is tied directly to the OUTL pin. As stated earlier, *output high*, or *OUT high* refers to the state when the OUTH pin is pulled close to  $V_{DD}$  pin bias voltage while the OUTL pin is in high-impedance state. Similarly *output low* or *OUT low* implies that the OUTL pin is pulled close to the GND pin while the OUTH pin is in high-impedance state.

9.3.1  $V_{DD}$  and Undervoltage Lockout

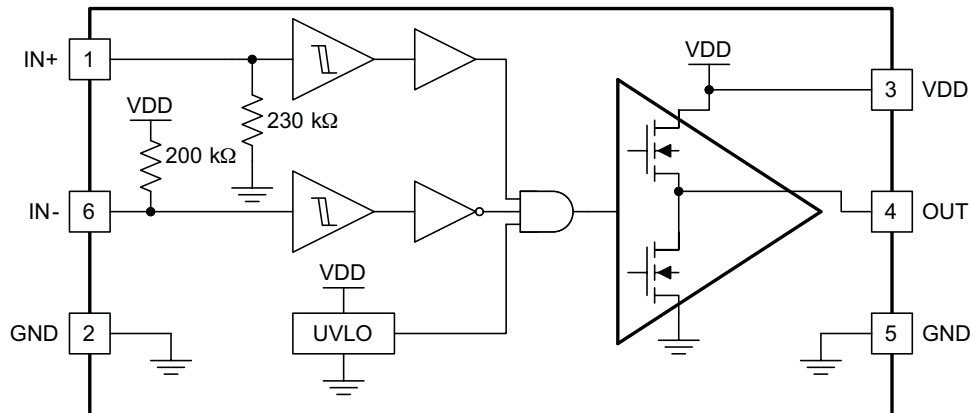
The UCC27511 and UCC27512 devices have internal Undervoltage LockOut (UVLO) protection feature on the  $V_{DD}$  pin supply circuit blocks. Whenever the driver is in UVLO condition (for example when  $V_{DD}$  voltage less than  $V_{ON}$  during power up and when  $V_{DD}$  voltage is less than  $V_{OFF}$  during power down), this circuit holds all outputs LOW, regardless of the status of the inputs. The UVLO is typically 4.2 V with 300-mV typical hysteresis. This hysteresis prevents chatter when low  $V_{DD}$  supply voltages have noise from the power supply and also when there are droops in the  $V_{DD}$  bias voltage when the system commences switching and there is a sudden increase in  $I_{DD}$ . The capability to operate at low voltage levels such as below 5 V, along with best-in-class switching characteristics, is especially suited for driving emerging GaN wide band-gap power-semiconductor devices.

For example, at power up, the UCC27511 and UCC27512 driver output remains LOW until the  $V_{DD}$  voltage reaches the UVLO threshold. The magnitude of the OUT signal rises with  $V_{DD}$  until steady-state  $V_{DD}$  is reached. In the noninverting operation (PWM signal applied to IN+ pin) shown in 图 21, the output remains LOW until the UVLO threshold is reached, and then the output is in-phase with the input. In the inverting operation (PWM signal applied to IN- pin) shown in 图 22 the output remains LOW until the UVLO threshold is reached, and then the output is out-phase with the input. In both cases, the unused input pin must be properly biased to enable the output. Note that in these devices the output turns to high state only if IN+ pin is high and IN- pin is low after the UVLO threshold is reached.

Since the driver draws current from the  $V_{DD}$  pin to bias all internal circuits, for the best high-speed circuit performance, two  $V_{DD}$ -bypass capacitors are recommended to prevent noise problems. The use of surface-mount components is highly recommended. A 0.1- $\mu$ F ceramic capacitor should be located as close as possible to the  $V_{DD}$  to GND pins of the gate driver. In addition, a larger capacitor (such as 1  $\mu$ F) with relatively low ESR should be connected in parallel and close proximity, in order to help deliver the high-current peaks required by the load. The parallel combination of capacitors should present a low impedance characteristic for the expected current levels and switching frequencies in the application.

## Feature Description (接下页)



图 21. Powerup (Noninverting Drive)



图 22. Powerup (Inverting Drive)

### 9.3.2 Operating Supply Current

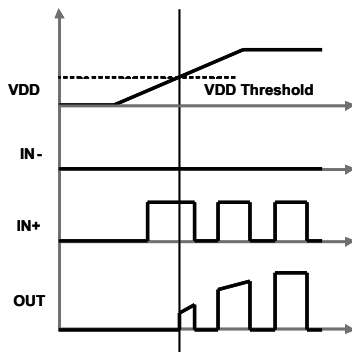
The UCC27511 and UCC27512 feature very low quiescent  $I_{DD}$  currents. The typical operating-supply current in Undervoltage LockOut (UVLO) state and fully-on state (under static and switching conditions) are summarized in 图 5, 图 6 and 图 7. The  $I_{DD}$  current when the device is fully on and outputs are in a static state (DC high or DC low, refer 图 7) represents lowest quiescent  $I_{DD}$  current when all the internal logic circuits of the device are fully operational. The total supply current is the sum of the quiescent  $I_{DD}$  current, the average  $I_{OUT}$  current due to switching, and finally any current related to pullup resistors on the unused input pin. For example, when the inverting input pin is pulled low additional current is drawn from  $V_{DD}$  supply through the pullup resistors (refer to for the device Block Diagram). Knowing the operating frequency ( $f_{SW}$ ) and the MOSFET gate ( $Q_G$ ) charge at the drive voltage being used, the average  $I_{OUT}$  current can be calculated as product of  $Q_G$  and  $f_{SW}$ .

A complete characterization of the  $I_{DD}$  current as a function of switching frequency at different  $V_{DD}$  bias voltages under 1.8-nF switching load is provided in 图 15. The strikingly linear variation and close correlation with theoretical value of average  $I_{OUT}$  indicates negligible shoot-through inside the gate-driver device attesting to its high-speed characteristics.

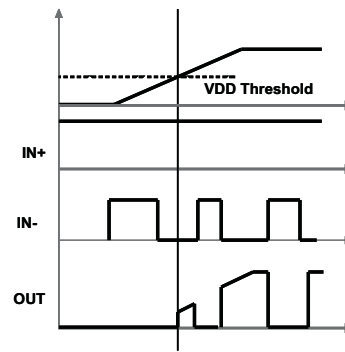
### 9.3.3 Input Stage

The input pins of the UCC27511 and UCC27512 devices are based on a TTL and CMOS compatible input-threshold logic that is independent of the  $V_{DD}$  supply voltage. With a typically high threshold of 2.2 V and a typically low threshold of 1.2 V, the logic-level thresholds can be conveniently driven with PWM control signals derived from 3.3-V and 5-V digital-power controllers. Wider hysteresis (1 V typical) offers enhanced noise immunity compared to traditional TTL-logic implementations, where the hysteresis is typically less than 0.5 V. This device also feature tight control of the input-pin threshold-voltage levels which eases system design considerations and ensures stable operation across temperature. The very-low input capacitance on these pins reduces loading and increases switching speed.

Whenever any of the input pins are in a floating condition, the output of the respective channel is held in the low state. This function is achieved using  $V_{DD}$ -pullup resistors on all the inverting inputs (IN– pin) or GND-pulldown resistors on all the noninverting input pins (IN+ pin), (see the ).

The device also features a dual-input configuration with two input pins available to control the state of the output. The user has the flexibility to drive the device using either a noninverting input pin (IN+) or an inverting input pin (IN–). The state of the output pin is dependent on the bias on both the IN+ and IN– pins. For additional clarification, refer to the I/O-logic truth table (表 3) and the typical application diagrams, (图 25 and 图 26).

When an input pin is selected for PWM drive, the other input pin (the *unused* input pin) must be properly biased in order to enable the output. As previously stated, the *unused* input pin cannot remain in a floating condition because whenever any input pin is left in a floating condition the output is disabled. Alternatively, the *unused* input pin can effectively be used to implement an enable or disable function. The following explains this function:

- In order to drive the device in a noninverting configuration, apply the PWM-control input signal to IN+ pin. In this case, the *unused* input pin, IN–, must be biased low (such as tied to GND) in order to enable the output.
  - Alternately, the IN– pin is used to implement the enable or disable function using an external logic signal. OUT is disabled when IN– is biased high and OUT is enabled when IN– is biased low.

## Feature Description (接下页)

- In order to drive the device in an inverting configuration, apply the PWM-control input signal to IN– pin. In this case, the *unused* input pin, IN+, must be biased high (such as tied to  $V_{DD}$ ) in order to enable the output.
  - Alternately, the IN+ pin is used to implement the enable or disable function using an external logic signal. OUT is disabled when IN+ is biased low and OUT is enabled when IN+ is biased high.
- Finally, note that the output pin can be driven into a high state **only** when the IN+ pin is biased high and the IN– input is biased low.

The input stage of the driver is preferably driven by a signal with a short rise or fall time. Use caution whenever the driver is used with slowly varying input signals, especially in situations where the device is located in a mechanical socket or PCB layout that is not optimal:

- High  $di/dt$  current from the driver output coupled with board layout parasitics can cause ground bounce. The differential voltage between input pins and GND is modified and triggers an unintended change of output state because of fast 13-ns propagation delay which can ultimately result in high-frequency oscillations that increase power dissipation and pose a risk of damage to the device.
- A 1-V input-threshold hysteresis boosts noise immunity compared to most other industry standard drivers.
- In the worst case, when a slow input signal is used and PCB layout is not optimal, adding a small capacitor (1 nF) between the input pin and GND pin very close to the driver device may be necessary which helps to convert the differential mode noise with respect to the input-logic circuitry into common-mode noise and avoid unintended change of output state.

If limiting the rise or fall times to the power device is the primary goal, then an external resistance is highly recommended between the output of the driver and the power device instead of adding delays on the input signal. This external resistor has the additional benefit of reducing part of the gate-charge related power dissipation in the gate-driver device package and transferring the power dissipation into the external resistor.

### 9.3.4 Enable Function

As mentioned earlier, an enable and disable function is easily implemented in UCC27511 and UCC27512 devices using the *unused* input pin. When the IN+ pin is pulled down to GND or the IN– pin is pulled down to  $V_{DD}$ , the output is disabled. Thus the IN+ pin can be used like an enable pin that is based on active-high logic, while the IN– pin can be used like an enable pin that is based on active-low logic.

### 9.3.5 Output Stage

 23 shows the output stage of the UCC27511 and UCC27512 devices. The UCC27511 and UCC27512 devices feature a unique architecture on the output stage which delivers the highest peak-source current when the peak source current is most needed during the Miller plateau region of the power switch turnon transition (when the power-switch drain or collector voltage experiences  $dV/dt$ ). The device output stage features a hybrid pullup structure using a parallel arrangement of N-channel and P-channel MOSFET devices. By turning on the N-channel MOSFET during a narrow instant when the output changes state from low to high, the gate-driver device is able to deliver a brief boost in the peak-sourcing current enabling fast turnon.

Feature Description (接下页)



图 23. UCC27511 Gate Driver Output Structure

The  $R_{O(H)}$  parameter (see the [Electrical Characteristics](#) table) is a DC measurement and is representative of the on-resistance of the P-channel device only, because the N-Channel device is turned on only during output change of state from low to high. Thus the effective resistance of the hybrid pullup stage is much lower than what is represented by  $R_{O(H)}$  parameter. The pulldown structure is composed of a N-channel MOSFET only. The  $R_{O(L)}$  parameter (see the [Electrical Characteristics](#) table), which is also a DC measurement, is representative of true impedance of the pulldown stage in the device. In the UCC27511 and UCC27512 devices, the effective resistance of the hybrid pullup structure is approximately  $2.7 \times R_{O(L)}$ .

The UCC27511 device features a unique split output configuration where the gate-drive current is sourced through the OUTH pin and sunk through the OUTL pin. This unique pin arrangement allows users to apply independent turnon and turnoff resistors to the OUTH and OUTL pins respectively and easily control the turnon and turnoff switching  $dV/dt$ . This pin arrangement, along with the low pulldown impedance of the output driver stage, is especially useful in applications where a high  $C \times dV/dt$  Miller turnon immunity is needed (such as with GaN power switches, SR MOSFETs and other applications) and the OUTL pin can be directly tied to the gate of the power device.

The UCC27511 and UCC27512 devices are capable of delivering 4-A source, 8-A sink (asymmetrical drive) at  $V_{DD}$  equal to 12 V. Strong sink capability in asymmetrical drive results in a very-low pulldown impedance in the driver output stage which boosts immunity against parasitic, Miller turnon ( $C \times dV/dt$  turnon) effect, especially where the low gate-charge MOSFETs or emerging wide band-gap GaN-power switches are used.

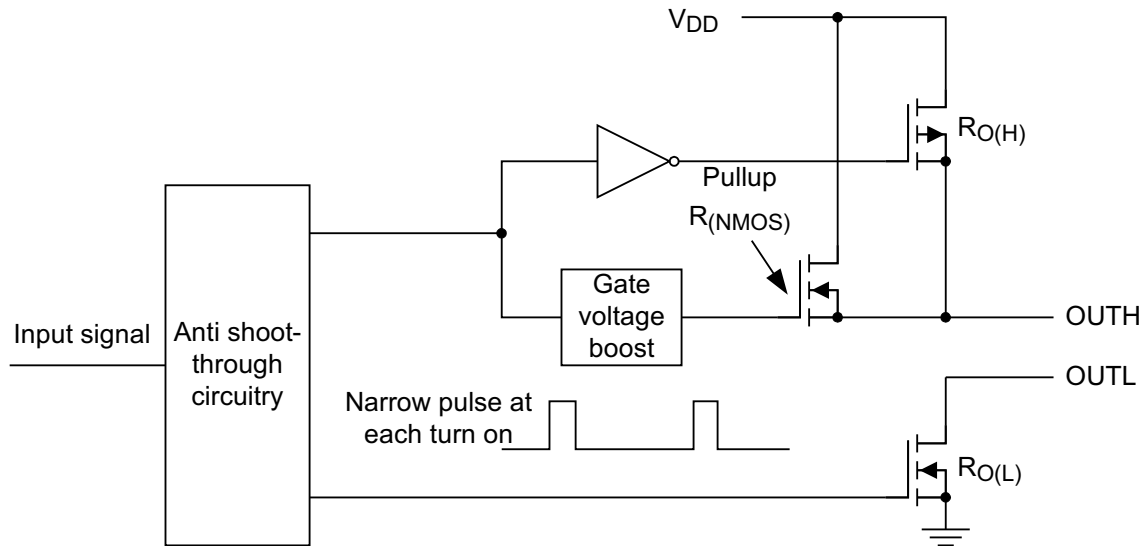
An example of a situation where the Miller turnon effect is a concern is synchronous rectification (SR). In an SR application, the  $dV/dt$  occurs on the MOSFET drain when the MOSFET is already held in off state by the gate driver. The current discharging the  $C_{(GD)}$  Miller capacitance during this  $dV/dt$  is shunted by the pulldown stage of the driver. If the pulldown impedance is not low enough then a voltage spike can result in the  $V_{GS}$  of the MOSFET, which can result in spurious turnon. This phenomenon is shown in [图 24](#). The UCC27511 and UCC27512 device offers a best-in-class, 0.375- $\Omega$  (typ) pulldown impedance boosting immunity against Miller turnon.

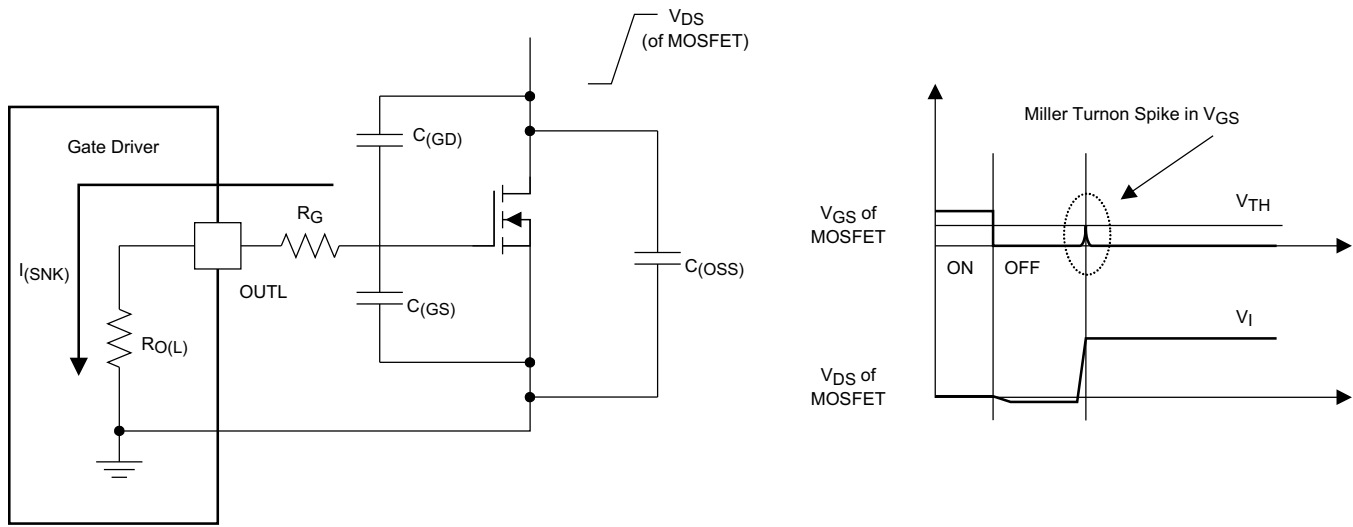
**Feature Description (接下页)**

**图 24. Very-Low Pulldown Impedance in UCC27511 and UCC27512, 4-A and 8-A Asymmetrical Drive (Output Stage Mitigates Miller Turnon Effect)**

The driver-output voltage swings between the  $V_{DD}$  and GND pins which provides rail-to-rail operation as a result of the MOS-output stage which delivers very-low dropout. The presence of the MOSFET-body diodes also offers low impedance to switching overshoots and undershoots. In many cases, external Schottky diode clamps are eliminated. The outputs of these drivers are designed to withstand 500-mA reverse current without either damage to the device or logic malfunction.

### 9.3.6 Low Propagation Delays

The UCC27511 and UCC27512 driver devices feature best-in-class input-to-output propagation delay of 13 ns (typ) at  $V_{DD} = 12$  V, which promises the lowest level of pulse transmission distortion available from industry-standard gate-driver devices for high-frequency switching applications. As seen in [图 14](#), there is very little variation of the propagation delay with temperature and supply voltage as well, offering typically less than 20-ns propagation delays across the entire range of application conditions.

## 9.4 Device Functional Modes

The device operates in normal mode and UVLO mode. See the *V<sub>DD</sub> and Undervoltage Lockout* section for information on UVLO operation mode. In the normal mode the output state is dependent on states of the IN+ and IN– pins. 表 3 lists the output states for different input pin combinations.

**表 3. Device Logic Table**

IN+ PIN	IN- PIN	OUTH PIN	OUTL PIN	OUT (OUTH and OUTL pins tied together in the UCC27511)
L	L	High impedance	L	L
L	H	High impedance	L	L
H	L	H	High impedance	H
H	H	High impedance	L	L
x <sup>(1)</sup>	Any	High impedance	L	L
Any	x <sup>(1)</sup>	High impedance	L	L

(1) x = Floating Condition

## 10 Application and Implementation

### 注

Information in the following applications sections is not part of the TI component specification, and TI does not warrant its accuracy or completeness. TI's customers are responsible for determining suitability of components for their purposes. Customers should validate and test their design implementation to confirm system functionality.

### 10.1 Application Information

High-current gate-driver devices are required in switching-power applications for a variety of reasons. In order to effect fast switching of power devices and reduce associated switching power losses, a powerful gate driver employs between the PWM output of controllers and the gates of the power-semiconductor devices. Further, gate drivers are indispensable when having the PWM controller directly drive the gates of the switching devices is impossible. With advent of digital power, this situation will be often encountered since the PWM signal from the digital controller is often a 3.3-V logic signal which is not capable of effectively turning on a power switch. A level-shifting circuitry is needed to boost the 3.3-V signal to the gate-drive voltage (such as 12 V) in order to fully turn on the power device and minimize conduction losses. Traditional buffer drive circuits based on NPN/PNP bipolar transistors in totem-pole arrangement, being emitter follower configurations, prove inadequate with digital power since they lack level-shifting capability. Gate drivers effectively combine both the level-shifting and buffer-drive functions. Gate drivers also find other needs such as minimizing the effect of high-frequency switching noise by locating the high-current driver physically close to the power switch, driving gate-drive transformers and controlling floating power-device gates, reducing power dissipation and thermal stress in controllers by moving gate charge power losses into itself. Finally, emerging wide band-gap power device technologies such as GaN based switches, which are capable of supporting very high switching frequency operation, are driving very special requirements in terms of gate drive capability. These requirements include operation at low  $V_{DD}$  voltages (5 V or lower), low propagation delays and availability in compact, low-inductance packages with good thermal capability. In summary gate-driver devices are extremely important components in switching power combining benefits of high-performance low-cost component count and board-space reduction and simplified system design.

### 10.2 Typical Application

Typical application diagrams of UCC27511 and UCC27512 devices are shown below illustrating use in non-inverting and inverting driver configurations. The UCC27511 device features a unique split output configuration where the gate-drive current is sourced through OUTH pin and sunk through OUTL pin. This unique pin arrangement allows user to apply independent turn-on and turn-off resistors to the OUTH and OUTL pins respectively and easily control the turn-on and turn-off switching  $dV/dt$ . This pin arrangement, along with the low pulldown impedance of the output driver stage, is especially handy in applications where a high  $C \times dV/dt$  Miller turnon immunity is needed (such as with GaN power switches, SR MOSFETs, and so forth) and OUTL pin can be directly tied to the gate of the power device.



图 25. Using Noninverting Input (IN– Is Grounded to Enable Output)

## Typical Application (接下页)

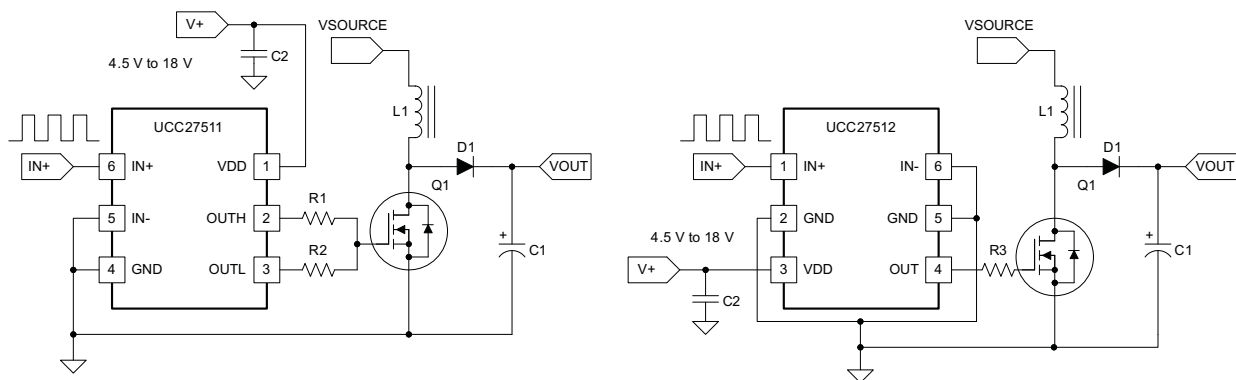

图 26. Using Inverting Input (IN+ Is Tied to  $V_{DD}$  Enable Output)

### 注

The UCC27512 features two ground pins, pin 2 and pin 5. TI recommends tying both pins together using PCB trace as close as possible to the device.

## 10.2.1 Design Requirements

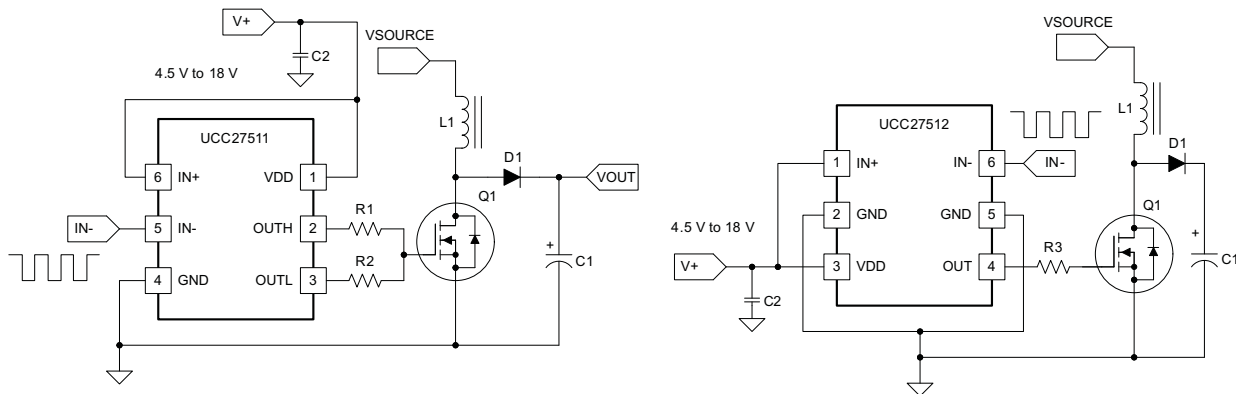
When selecting the proper gate driver device for an end application, some design considerations must be evaluated first in order to make the most appropriate selection. Among these considerations are input-to-output configuration, the input threshold type, bias supply voltage levels, peak source and sink currents, availability of independent enable and disable functions, propagation delay, power dissipation, and package type.

## 10.2.2 Detailed Design Procedure

### 10.2.2.1 Input-to-Output Logic

The design should specify which type of input-to-output configuration should be used. If turning on the power MOSFET or IGBT when the input signal is in high state is preferred, then the non-inverting configuration must be selected. If turning off the power MOSFET or IGBT when the input signal is in high state is preferred, the inverting configuration must be chosen. The UCC27511 and UCC27512 devices can be configured in either an inverting or noninverting input-to-output configuration using the IN– or IN+ pins respectively. To configure the device for use in inverting mode, tie the IN+ pin to  $V_{DD}$  and apply the input signal to the IN– pin. For the noninverting configuration, tie the IN– pin to GND and apply the input signal to the IN+ pin.

### 10.2.2.2 Input Threshold Type

The type of Input voltage threshold determines the type of controller that can be used with the gate driver device. The UCC27511 and UCC27512 devices feature a TTL and CMOS-compatible input threshold logic, with wide hysteresis. The threshold voltage levels are low voltage and independent of the  $V_{DD}$  supply voltage, which allows compatibility with both logic-level input signals from microcontrollers as well as higher-voltage input signals from analog controllers. See the [Electrical Characteristics](#) table for the actual input threshold voltage levels and hysteresis specifications for the UCC27511 and UCC27512 devices.

### 10.2.2.3 $V_{DD}$ Bias Supply Voltage

The bias supply voltage to be applied to the  $V_{DD}$  pin of the device should never exceed the values listed in the [Recommended Operating Conditions](#) table. However, different power switches demand different voltage levels to be applied at the gate terminals for effective turnon and turnoff. With certain power switches, a positive gate voltage may be required for turnon and a negative gate voltage may be required for turnoff, in which case the  $V_{DD}$  bias supply equals the voltage differential. With a wide operating range from 4.5 V to 18 V, the UCC27511 and UCC27512 devices can be used to drive a variety of power switches, such as Si MOSFETs (for example,  $V_{GS} = 4.5\text{ V}, 10\text{ V}, 12\text{ V}$ ), IGBTs ( $V_{GE} = 15\text{ V}, 18\text{ V}$ ), and wide-bandgap power semiconductors (such as GaN, certain types of which allow no higher than 6 V to be applied to the gate terminals).

## Typical Application (接下页)

### 10.2.2.4 Peak Source and Sink Currents

Generally, the switching speed of the power switch during turnon and turnoff should be as fast as possible in order to minimize switching power losses. The gate driver device must be able to provide the required peak current for achieving the targeted switching speeds for the targeted power MOSFET.

Using the example of a power MOSFET, the system requirement for the switching speed is typically described in terms of the slew rate of the drain-to-source voltage of the power MOSFET (such as  $dV_{DS}/dt$ ). For example, the system requirement might state that a SPP20N60C3 power MOSFET must be turned-on with a  $dV_{DS}/dt$  of 20 V/ns or higher under a DC bus voltage of 400 V in a continuous-conduction-mode (CCM) boost PFC-converter application. This type of application is an inductive hard-switching application and reducing switching power losses is critical. This requirement means that the entire drain-to-source voltage swing during power MOSFET turn-on event (from 400 V in the OFF state to  $V_{DS(on)}$  in on state) must be completed in approximately 20 ns or less. When the drain-to-source voltage swing occurs, the Miller charge of the power MOSFET ( $Q_{GD}$  parameter in SPP20N60C3 power MOSFET data sheet = 33 nC typical) is supplied by the peak current of gate driver. According to power MOSFET inductive switching mechanism, the gate-to-source voltage of the power MOSFET at this time is the Miller plateau voltage, which is typically a few volts higher than the threshold voltage of the power MOSFET,  $V_{GS(TH)}$ .

In order to achieve the targeted  $dV_{DS}/dt$ , the gate driver must be capable of providing the  $Q_{GD}$  charge in 20 ns or less. In other words a peak current of 1.65 A (= 33 nC / 20 ns) or higher must be provided by the gate driver. The UCC27511 and UCC27512 gate driver is capable of providing 4-A peak sourcing current which clearly exceeds the design requirement and has the capability to meet the switching speed needed. The 2.4x overdrive capability provides an extra margin against part-to-part variations in the  $Q_{GD}$  parameter of the power MOSFET along with additional flexibility to insert external gate resistors and fine tune the switching speed for efficiency versus EMI optimizations.

However, in practical designs the parasitic trace inductance in the gate drive circuit of the PCB will have a definitive role to play on the power MOSFET switching speed. The effect of this trace inductance is to limit the  $di/dt$  of the output current pulse of the gate driver. In order to illustrate this, consider output current pulse waveform from the gate driver to be approximated to a triangular profile, where the area under the triangle ( $\frac{1}{2} \times I_{PEAK} \times \text{time}$ ) would equal the total gate charge of the power MOSFET ( $Q_G$  parameter in SPP20N60C3 power MOSFET datasheet = 87 nC typical). If the parasitic trace inductance limits the  $di/dt$  then a situation may occur in which the full peak current capability of the gate driver is not fully achieved in the time required to deliver the  $Q_G$  required for the power MOSFET switching. In other words the time parameter in the equation would dominate and the  $I_{PEAK}$  value of the current pulse would be much less than the true peak current capability of the device, while the required  $Q_G$  is still delivered. Because of this, the desired switching speed may not be realized, even when theoretical calculations indicate the gate driver is capable of achieving the targeted switching speed. Thus, placing the gate driver device very close to the power MOSFET and designing a tight gate drive-loop with minimal PCB trace inductance is important to realize the full peak-current capability of the gate driver.

### 10.2.2.5 Enable and Disable Function

Certain applications demand independent control of the output state of the driver without involving the input signal. A pin which offers an enable and disable function achieves this requirement. The UCC27511 and UCC27512 devices offer 2 input pins, IN+ and IN–, both of which control the state of the output as listed in 表 3. Based on whether an inverting or noninverting input signal is provided to the driver, the appropriate input pin can be selected as the primary input for controlling the gate driver. The other *unused* input pin can be conveniently used for the enable and disable functionality. If the design does not require an enable function, the unused input pin can be tied to either the  $V_{DD}$  pin (in case IN+ is the unused pin), or GND (in case IN– is unused pin) in order to ensure it does not affect the output status.

### 10.2.2.6 Propagation Delay

The acceptable propagation delay from the gate driver is dependent on the switching frequency at which it is used and the acceptable level of pulse distortion to the system. The UCC27511 and UCC27512 devices feature industry best-in-class 13-ns (typical) propagation delays which ensures very little pulse distortion and allows operation at very high-frequencies. See the table for the propagation and switching characteristics of the UCC27511 and UCC27512 devices.

## Typical Application (接下页)

### 10.2.2.7 Thermal Information

The useful range of a driver is greatly affected by the drive-power requirements of the load and the thermal characteristics of the package. In order for a gate driver to be useful over a particular temperature range the package must allow for the efficient removal of the heat produced while keeping the junction temperature within rated limits. The thermal metrics for the driver package is listed in the table. For detailed information regarding the table, please refer to the Application Note from Texas Instruments entitled *IC Package Thermal Metrics (SPRA953)*.

The UCC27511 device is offered in a SOT-23, 6-pin package (DBV). The section lists the thermal performance metrics related to SOT-23 package. The  $\psi_{JT}$  and  $\psi_{JB}$  metrics are used when estimating the die temperature during actual application measurements.

Heat removal occurs primarily through the leads of the device and the PCB traces connected to the leads.

### 10.2.2.8 Power Dissipation

Power dissipation of the gate driver has two portions as shown in [公式 1](#).

$$P_{DISS} = P_{DC} + P_{SW} \quad (1)$$

The DC portion of the power dissipation is  $P_{DC} = I_Q \times V_{DD}$  where  $I_Q$  is the quiescent current for the driver. The quiescent current is the current consumed by the device to bias all internal circuits such as input stage, reference voltage, logic circuits, protections, and also any current associated with switching of internal devices when the driver output changes state (such as charging and discharging of parasitic capacitances, parasitic shoot-through, and so forth). The UCC27511 and UCC27512 features very low quiescent currents (less than 1 mA, refer [图 7](#)) and contains internal logic to eliminate any shoot-through in the output driver stage. Thus the effect of the  $P_{DC}$  on the total power dissipation within the gate driver can be safely assumed to be negligible.

The power dissipated in the gate-driver package during switching ( $P_{SW}$ ) depends on the following factors:

- Gate charge required of the power device (usually a function of the drive voltage  $V_G$ , which is very close to input bias supply voltage  $V_{DD}$  due to low  $V_{OH}$  drop-out).
- Switching frequency.
- Use of external gate resistors.

When a driver device is tested with a discrete, capacitive load calculating the power that is required from the bias supply is fairly simple. The energy that must be transferred from the bias supply to charge the capacitor is given by [公式 2](#).

$$E_G = \frac{1}{2} C_{LOAD} V_{DD}^2$$

where

- $C_{LOAD}$  is load capacitor
- $V_{DD}$  is bias voltage feeding the driver

There is an equal amount of energy dissipated when the capacitor is charged. This leads to a total power loss given by [公式 3](#).

$$P_G = C_{LOAD} V_{DD}^2 f_{SW}$$

where

- $f_{SW}$  is the switching frequency

The switching load presented by a power MOSFET/IGBT is converted to an equivalent capacitance by examining the gate charge required to switch the device. This gate charge includes the effects of the input capacitance plus the added charge needed to swing the drain voltage of the power device as it switches between the ON and OFF states. Most manufacturers provide specifications of typical and maximum gate charge, in nC, to switch the device under specified conditions. Using the gate charge  $Q_g$ , determine the power that must be dissipated when charging a capacitor which is calculated using the equation,  $Q_g = C_{LOAD} \times V_{DD}$ , to provide [公式 4](#) for power.

$$P_G = C_{LOAD} V_{DD}^2 f_{SW} = Q_g V_{DD} f_{SW} \quad (4)$$

### Typical Application (接下页)

This power  $P_G$  is dissipated in the resistive elements of the circuit when the MOSFET/IGBT is being turned on or off. Half of the total power is dissipated when the load capacitor is charged during turnon, and the other half is dissipated when the load capacitor is discharged during turnoff. When no external gate resistor is employed between the driver and MOSFET/IGBT, this power is completely dissipated inside the driver package. With the use of external gate-drive resistors, the power dissipation is shared between the internal resistance of driver and external gate resistor in accordance to the ratio of the resistances (more power dissipated in the higher resistance component). Based on this simplified analysis, the driver power dissipation during switching is calculated in 公式 5.

$$P_{SW} = 0.5 \times Q_G \times V_{DD} \times f_{SW} \times \left( \frac{R_{OFF}}{R_{OFF} + R_{GATE}} + \frac{R_{ON}}{R_{ON} + R_{GATE}} \right)$$

where

- $R_{OFF} = R_{OL}$
- $R_{ON}$  (effective resistance of pull-up structure) =  $2.7 \times R_{OL}$  (5)

### 10.2.3 Application Curves

图 27 和 图 28 show the typical switching characteristics of the UCC27511 device.

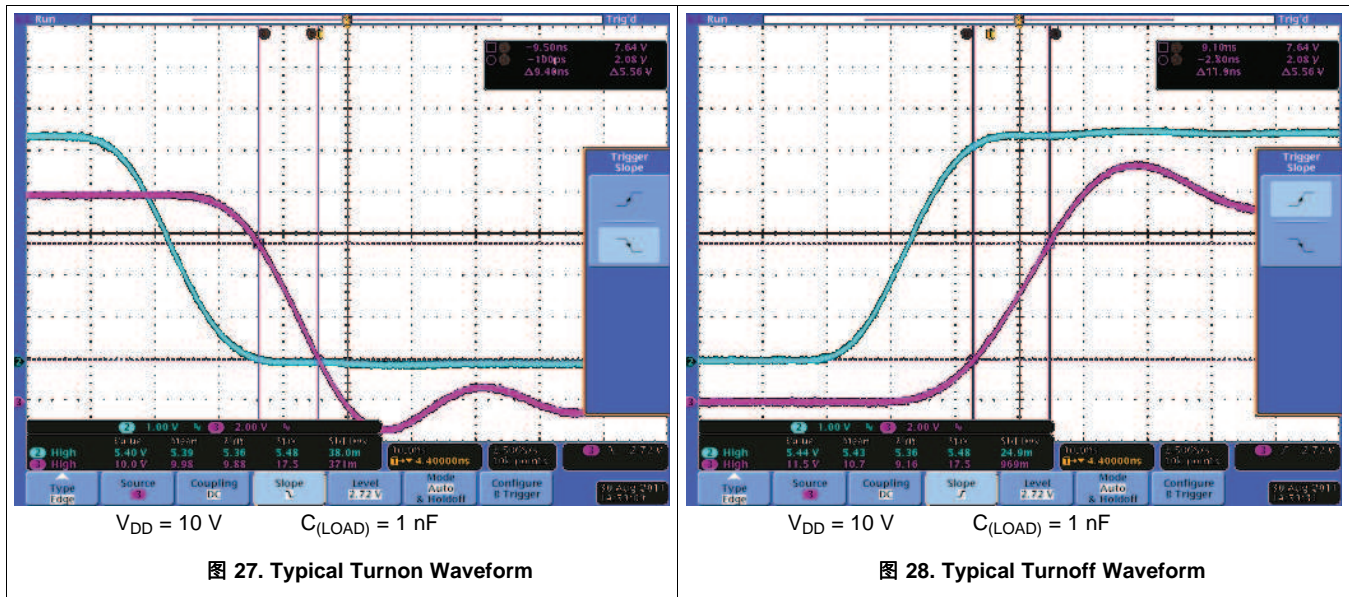

## 11 Power Supply Recommendations

The bias supply voltage range for which the UCC27511 and UCC27512 device is rated to operate is from 4.5 V to 18 V. The lower end of this range is governed by the internal undervoltage-lockout (UVLO) protection feature on the  $V_{DD}$  pin supply circuit blocks. Whenever the driver is in UVLO condition when the  $V_{DD}$  pin voltage is below the  $V_{(ON)}$  supply start threshold, this feature holds the output low, regardless of the status of the inputs. The upper end of this range is driven by the 20-V absolute maximum voltage rating of the  $V_{DD}$  pin of the device (which is a stress rating). Keeping a 2-V margin to allow for transient voltage spikes, the maximum recommended voltage for the  $V_{DD}$  pin is 18 V.

The UVLO protection feature also involves a hysteresis function. This means that when the  $V_{DD}$  pin bias voltage has exceeded the threshold voltage and device begins to operate, and if the voltage drops, then the device continues to deliver normal functionality unless the voltage drop exceeds the hysteresis specification  $V_{DD(hys)}$ . Therefore, ensuring that, while operating at or near the 4.5 V range, the voltage ripple on the auxiliary power supply output is smaller than the hysteresis specification of the device is important to avoid triggering device shutdown.

During system shutdown, the device operation continues until the  $V_{DD}$  pin voltage has dropped below the  $V_{(OFF)}$  threshold which must be accounted for while evaluating system shutdown timing design requirements. Likewise, at system startup, the device does not begin operation until the  $V_{DD}$  pin voltage has exceeded above the  $V_{(ON)}$  threshold.

The quiescent current consumed by the internal circuit blocks of the device is supplied through the  $V_{DD}$  pin. Although this fact is well known, recognizing that the charge for source current pulses delivered by the OUTH pin is also supplied through the same  $V_{DD}$  pin is important. As a result, every time a current is sourced out of the output pins (OUTH), a corresponding current pulse is delivered into the device through the  $V_{DD}$  pin. Thus ensuring that local bypass capacitors are provided between the  $V_{DD}$  and GND pins and located as close to the device as possible for the purpose of decoupling is important. A low ESR, ceramic surface mount capacitor is a must. TI recommends to have 2 capacitors; a 100-nF ceramic surface-mount capacitor which can be nudged very close to the pins of the device and another surface-mount capacitor of few microfarads added in parallel.

## 12 Layout

### 12.1 Layout Guidelines

Proper PCB layout is extremely important in a high-current fast-switching circuit to provide appropriate device operation and design robustness. The UCC27511 and UCC27512 gate driver incorporates short-propagation delays and powerful output stages capable of delivering large current peaks with very fast rise and fall times at the gate of power switch to facilitate voltage transitions very quickly. At higher  $V_{DD}$  voltages, the peak-current capability is even higher (4-A/8-A peak current is at  $V_{DD} = 12$  V). Very high  $di/dt$  causes unacceptable ringing if the trace lengths and impedances are not well controlled. The following circuit-layout guidelines are strongly recommended when designing with these high-speed drivers.

- Locate the driver device as close as possible to power device in order to minimize the length of high-current traces between the output pins and the gate of the power device.
- Locate the  $V_{DD}$ -bypass capacitors between  $V_{DD}$  and GND as close as possible to the driver with minimal trace length to improve the noise filtering. These capacitors support high-peak current being drawn from  $V_{DD}$  during turnon of power MOSFET. The use of low inductance SMD components such as chip resistors and chip capacitors is highly recommended.
- The turnon and turnoff current-loop paths (driver device, power MOSFET and  $V_{DD}$  bypass capacitor) should be minimized as much as possible in order to keep the stray inductance to a minimum. High  $di/dt$  is established in these loops at two instances – during turnon and turnoff transients, which will induce significant voltage transients on the output pin of the driver device and gate of the power switch.
- Wherever possible, parallel the source and return traces, taking advantage of flux cancellation.
- Separate power traces and signal traces, such as output and input signals.
- Star-point grounding is a good way to minimize noise coupling from one current loop to another. The GND of the driver should be connected to the other circuit nodes such as source of power switch, ground of PWM controller, and so forth, at one, single point. The connected paths should be as short as possible to reduce inductance and be as wide as possible to reduce resistance.
- Use a ground plane to provide noise shielding. Fast rise and fall times at OUT may corrupt the input signals

## Layout Guidelines (接下页)

during transition. The ground plane must not be a conduction path for any current loop. Instead the ground plane must be connected to the star-point with one single trace to establish the ground potential. In addition to noise shielding, the ground plane can help in power dissipation as well.

- In noisy environments, tying the unused Input pin of UCC27511 and UCC27512 to  $V_{DD}$  (in case of IN+) or GND (in case of IN-) using short traces in order to ensure that the output is enabled and to prevent noise from causing malfunction in the output may be necessary.
- The UCC27512 device offers two ground pins, pin 2 and pin 5. Shorting the two pins together using the PCB trace is extremely important. The shortest trace should be located as close as possible to the device.

## 12.2 Layout Example



图 29. UCC27511 Layout Example

## 13 器件和文档支持

### 13.1 相关链接

下面的表格列出了快速访问链接。范围包括技术文档、支持与社区资源、工具和软件，以及样片或购买的快速访问。

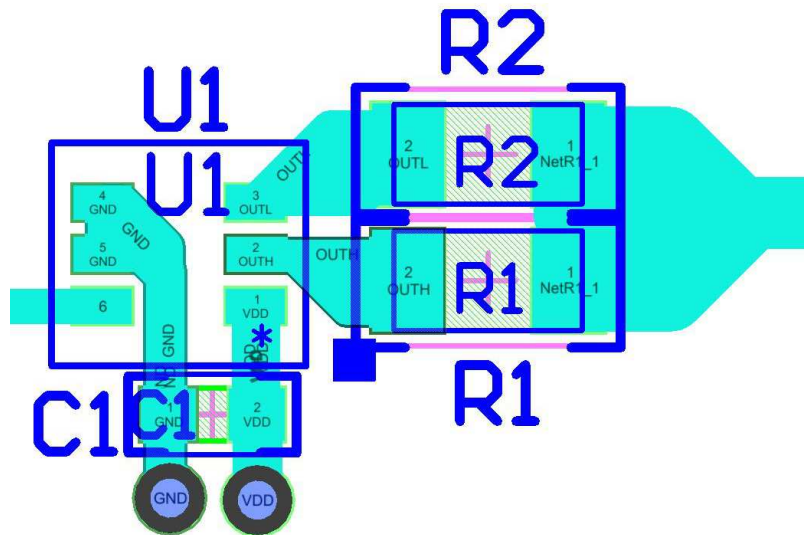
表 4. 相关链接

部件	产品文件夹	样片与购买	技术文档	工具与软件	支持与社区
UCC27511	<a href="#">请单击此处</a>	<a href="#">请单击此处</a>	<a href="#">请单击此处</a>	<a href="#">请单击此处</a>	<a href="#">请单击此处</a>
UCC27512	<a href="#">请单击此处</a>	<a href="#">请单击此处</a>	<a href="#">请单击此处</a>	<a href="#">请单击此处</a>	<a href="#">请单击此处</a>

### 13.2 商标

All trademarks are the property of their respective owners.

### 13.3 静电放电警告



这些装置包含有限的内置 ESD 保护。存储或装卸时，应将导线一起截短或将装置放置于导电泡棉中，以防止 MOS 门极遭受静电损伤。

### 13.4 术语表

[SLYZ022](#) — TI 术语表。

这份术语表列出并解释术语、首字母缩略词和定义。

## 14 机械、封装和可订购信息

以下页中包括机械、封装和可订购信息。这些信息是针对指定器件可提供的最新数据。这些数据会在无通知且不对本文档进行修订的情况下发生改变。欲获得该数据表的浏览器版本，请查阅左侧的导航栏。

## 重要声明

德州仪器(TI)及其下属子公司有权根据 JESD46 最新标准,对所提供的产品和服务进行更正、修改、增强、改进或其它更改,并有权根据 JESD48 最新标准中止提供任何产品和服务。客户在下订单前应获取最新的相关信息,并验证这些信息是否完整且是最新的。所有产品的销售都遵循在订单确认时所提供的TI 销售条款与条件。

TI 保证其所销售的组件的性能符合产品销售时 TI 半导体产品销售条件与条款的适用规范。仅在 TI 保证的范围内,且 TI 认为有必要时才会使用测试或其它质量控制技术。除非适用法律做出了硬性规定,否则没有必要对每种组件的所有参数进行测试。

TI 对应用帮助或客户产品设计不承担任何义务。客户应对其使用 TI 组件的产品和应用自行负责。为尽量减小与客户产品和应用相关的风险,客户应提供充分的设计与操作安全措施。

TI 不对任何 TI 专利权、版权、屏蔽作品权或其它与使用了 TI 组件或服务的组合设备、机器或流程相关的 TI 知识产权中授予的直接或隐含权限作出任何保证或解释。TI 所发布的与第三方产品或服务有关的信息,不能构成从 TI 获得使用这些产品或服务的许可、授权、或认可。使用此类信息可能需要获得第三方的专利权或其它知识产权方面的许可,或是 TI 的专利权或其它知识产权方面的许可。

对于 TI 的产品手册或数据表中 TI 信息的重要部分,仅在没有对内容进行任何篡改且带有相关授权、条件、限制和声明的情况下才允许进行复制。TI 对此类篡改过的文件不承担任何责任或义务。复制第三方的信息可能需要服从额外的限制条件。

在转售 TI 组件或服务时,如果对该组件或服务参数的陈述与 TI 标明的参数相比存在差异或虚假成分,则会失去相关 TI 组件或服务的所有明示或暗示授权,且这是不正当的、欺诈性商业行为。TI 对任何此类虚假陈述均不承担任何责任或义务。

客户认可并同意,尽管任何应用相关信息或支持仍可能由 TI 提供,但他们将独立负责满足与其产品及其在应用中使用的 TI 产品相关的所有法律、法规和安全相关要求。客户声明并同意,他们具备制定与实施安全措施所需的全部专业技术和知识,可预见故障的危险后果、监测故障及其后果、降低有可能造成人身伤害的故障的发生机率并采取适当的补救措施。客户将全额赔偿因在此类安全关键应用中使用任何 TI 组件而对 TI 及其代理造成的任何损失。

在某些场合中,为了推进安全相关应用有可能对 TI 组件进行特别的促销。TI 的目标是利用此类组件帮助客户设计和创立其特有的可满足适用的功能安全性标准和要求的终端产品解决方案。尽管如此,此类组件仍然服从这些条款。

TI 组件未获得用于 FDA Class III (或类似的生命攸关医疗设备)的授权许可,除非各方授权官员已经达成了专门管控此类使用的特别协议。

只有那些 TI 特别注明属于军用等级或“增强型塑料”的 TI 组件才是设计或专门用于军事/航空应用或环境的。购买者认可并同意,对并非指定面向军事或航空航天用途的 TI 组件进行军事或航空航天方面的应用,其风险由客户单独承担,并且由客户独立负责满足与此类使用相关的所有法律和法规要求。

TI 已明确指定符合 ISO/TS16949 要求的产品,这些产品主要用于汽车。在任何情况下,因使用非指定产品而无法达到 ISO/TS16949 要求, TI 不承担任何责任。

	产品		应用
数字音频	<a href="http://www.ti.com.cn/audio">www.ti.com.cn/audio</a>	通信与电信	<a href="http://www.ti.com.cn/telecom">www.ti.com.cn/telecom</a>
放大器和线性器件	<a href="http://www.ti.com.cn/amplifiers">www.ti.com.cn/amplifiers</a>	计算机及周边	<a href="http://www.ti.com.cn/computer">www.ti.com.cn/computer</a>
数据转换器	<a href="http://www.ti.com.cn/dataconverters">www.ti.com.cn/dataconverters</a>	消费电子	<a href="http://www.ti.com.cn/consumer-apps">www.ti.com.cn/consumer-apps</a>
DLP® 产品	<a href="http://www.dlp.com">www.dlp.com</a>	能源	<a href="http://www.ti.com.cn/energy">www.ti.com.cn/energy</a>
DSP - 数字信号处理器	<a href="http://www.ti.com.cn/dsp">www.ti.com.cn/dsp</a>	工业应用	<a href="http://www.ti.com.cn/industrial">www.ti.com.cn/industrial</a>
时钟和计时器	<a href="http://www.ti.com.cn/clockandtimers">www.ti.com.cn/clockandtimers</a>	医疗电子	<a href="http://www.ti.com.cn/medical">www.ti.com.cn/medical</a>
接口	<a href="http://www.ti.com.cn/interface">www.ti.com.cn/interface</a>	安防应用	<a href="http://www.ti.com.cn/security">www.ti.com.cn/security</a>
逻辑	<a href="http://www.ti.com.cn/logic">www.ti.com.cn/logic</a>	汽车电子	<a href="http://www.ti.com.cn/automotive">www.ti.com.cn/automotive</a>
电源管理	<a href="http://www.ti.com.cn/power">www.ti.com.cn/power</a>	视频和影像	<a href="http://www.ti.com.cn/video">www.ti.com.cn/video</a>
微控制器 (MCU)	<a href="http://www.ti.com.cn/microcontrollers">www.ti.com.cn/microcontrollers</a>		
RFID 系统	<a href="http://www.ti.com.cn/rfidsys">www.ti.com.cn/rfidsys</a>		
OMAP应用处理器	<a href="http://www.ti.com/omap">www.ti.com/omap</a>		
无线连通性	<a href="http://www.ti.com.cn/wirelessconnectivity">www.ti.com.cn/wirelessconnectivity</a>	德州仪器在线技术支持社区	<a href="http://www.deyisupport.com">www.deyisupport.com</a>

邮寄地址: 上海市浦东新区世纪大道1568号, 中建大厦32楼邮政编码: 200122  
Copyright © 2016, 德州仪器半导体技术(上海)有限公司

**PACKAGING INFORMATION**

Orderable Device	Status (1)	Package Type	Package Drawing	Pins	Package Qty	Eco Plan (2)	Lead/Ball Finish (6)	MSL Peak Temp (3)	Op Temp (°C)	Device Marking (4/5)	Samples
UCC27511DBVR	ACTIVE	SOT-23	DBV	6	3000	Green (RoHS & no Sb/Br)	CU NIPDAU	Level-1-260C-UNLIM	-40 to 140	7511	<a href="#">Samples</a>
UCC27511DBVT	ACTIVE	SOT-23	DBV	6	250	Green (RoHS & no Sb/Br)	CU NIPDAU	Level-1-260C-UNLIM	-40 to 140	7511	<a href="#">Samples</a>
UCC27512DRSR	ACTIVE	SON	DRS	6	3000	Green (RoHS & no Sb/Br)	CU NIPDAU	Level-2-260C-1 YEAR	-40 to 140	27512	<a href="#">Samples</a>
UCC27512DRST	ACTIVE	SON	DRS	6	250	Green (RoHS & no Sb/Br)	CU NIPDAU	Level-2-260C-1 YEAR	-40 to 140	27512	<a href="#">Samples</a>

(1) The marketing status values are defined as follows:

**ACTIVE:** Product device recommended for new designs.

**LIFEBUY:** TI has announced that the device will be discontinued, and a lifetime-buy period is in effect.

**NRND:** Not recommended for new designs. Device is in production to support existing customers, but TI does not recommend using this part in a new design.

**PREVIEW:** Device has been announced but is not in production. Samples may or may not be available.

**OBSOLETE:** TI has discontinued the production of the device.

(2) Eco Plan - The planned eco-friendly classification: Pb-Free (RoHS), Pb-Free (RoHS Exempt), or Green (RoHS & no Sb/Br) - please check <http://www.ti.com/productcontent> for the latest availability information and additional product content details.

**TBD:** The Pb-Free/Green conversion plan has not been defined.

**Pb-Free (RoHS):** TI's terms "Lead-Free" or "Pb-Free" mean semiconductor products that are compatible with the current RoHS requirements for all 6 substances, including the requirement that lead not exceed 0.1% by weight in homogeneous materials. Where designed to be soldered at high temperatures, TI Pb-Free products are suitable for use in specified lead-free processes.

**Pb-Free (RoHS Exempt):** This component has a RoHS exemption for either 1) lead-based flip-chip solder bumps used between the die and package, or 2) lead-based die adhesive used between the die and leadframe. The component is otherwise considered Pb-Free (RoHS compatible) as defined above.

**Green (RoHS & no Sb/Br):** TI defines "Green" to mean Pb-Free (RoHS compatible), and free of Bromine (Br) and Antimony (Sb) based flame retardants (Br or Sb do not exceed 0.1% by weight in homogeneous material)

(3) MSL, Peak Temp. - The Moisture Sensitivity Level rating according to the JEDEC industry standard classifications, and peak solder temperature.

(4) There may be additional marking, which relates to the logo, the lot trace code information, or the environmental category on the device.

(5) Multiple Device Markings will be inside parentheses. Only one Device Marking contained in parentheses and separated by a "~" will appear on a device. If a line is indented then it is a continuation of the previous line and the two combined represent the entire Device Marking for that device.

(6) Lead/Ball Finish - Orderable Devices may have multiple material finish options. Finish options are separated by a vertical ruled line. Lead/Ball Finish values may wrap to two lines if the finish value exceeds the maximum column width.

**Important Information and Disclaimer:** The information provided on this page represents TI's knowledge and belief as of the date that it is provided. TI bases its knowledge and belief on information provided by third parties, and makes no representation or warranty as to the accuracy of such information. Efforts are underway to better integrate information from third parties. TI has taken and continues to take reasonable steps to provide representative and accurate information but may not have conducted destructive testing or chemical analysis on incoming materials and chemicals. TI and TI suppliers consider certain information to be proprietary, and thus CAS numbers and other limited information may not be available for release.

In no event shall TI's liability arising out of such information exceed the total purchase price of the TI part(s) at issue in this document sold by TI to Customer on an annual basis.

**OTHER QUALIFIED VERSIONS OF UCC27512 :**

- Enhanced Product: [UCC27512-EP](#)

NOTE: Qualified Version Definitions:

- Enhanced Product - Supports Defense, Aerospace and Medical Applications

**TAPE AND REEL INFORMATION**

**QUADRANT ASSIGNMENTS FOR PIN 1 ORIENTATION IN TAPE**

\*All dimensions are nominal

Device	Package Type	Package Drawing	Pins	SPQ	Reel Diameter (mm)	Reel Width W1 (mm)	A0 (mm)	B0 (mm)	K0 (mm)	P1 (mm)	W (mm)	Pin1 Quadrant
UCC27511DBVR	SOT-23	DBV	6	3000	179.0	8.4	3.2	3.2	1.4	4.0	8.0	Q3
UCC27511DBVT	SOT-23	DBV	6	250	179.0	8.4	3.2	3.2	1.4	4.0	8.0	Q3
UCC27512DRSR	SON	DRS	6	3000	330.0	12.4	3.3	3.3	1.1	8.0	12.0	Q2
UCC27512DRST	SON	DRS	6	250	180.0	12.4	3.3	3.3	1.1	8.0	12.0	Q2

## TAPE AND REEL BOX DIMENSIONS



\*All dimensions are nominal

Device	Package Type	Package Drawing	Pins	SPQ	Length (mm)	Width (mm)	Height (mm)
UCC27511DBVR	SOT-23	DBV	6	3000	203.0	203.0	35.0
UCC27511DBVT	SOT-23	DBV	6	250	203.0	203.0	35.0
UCC27512DRSR	SON	DRS	6	3000	367.0	367.0	35.0
UCC27512DRST	SON	DRS	6	250	210.0	185.0	35.0

# MECHANICAL DATA

DBV (R-PDSO-G6)

PLASTIC SMALL-OUTLINE PACKAGE

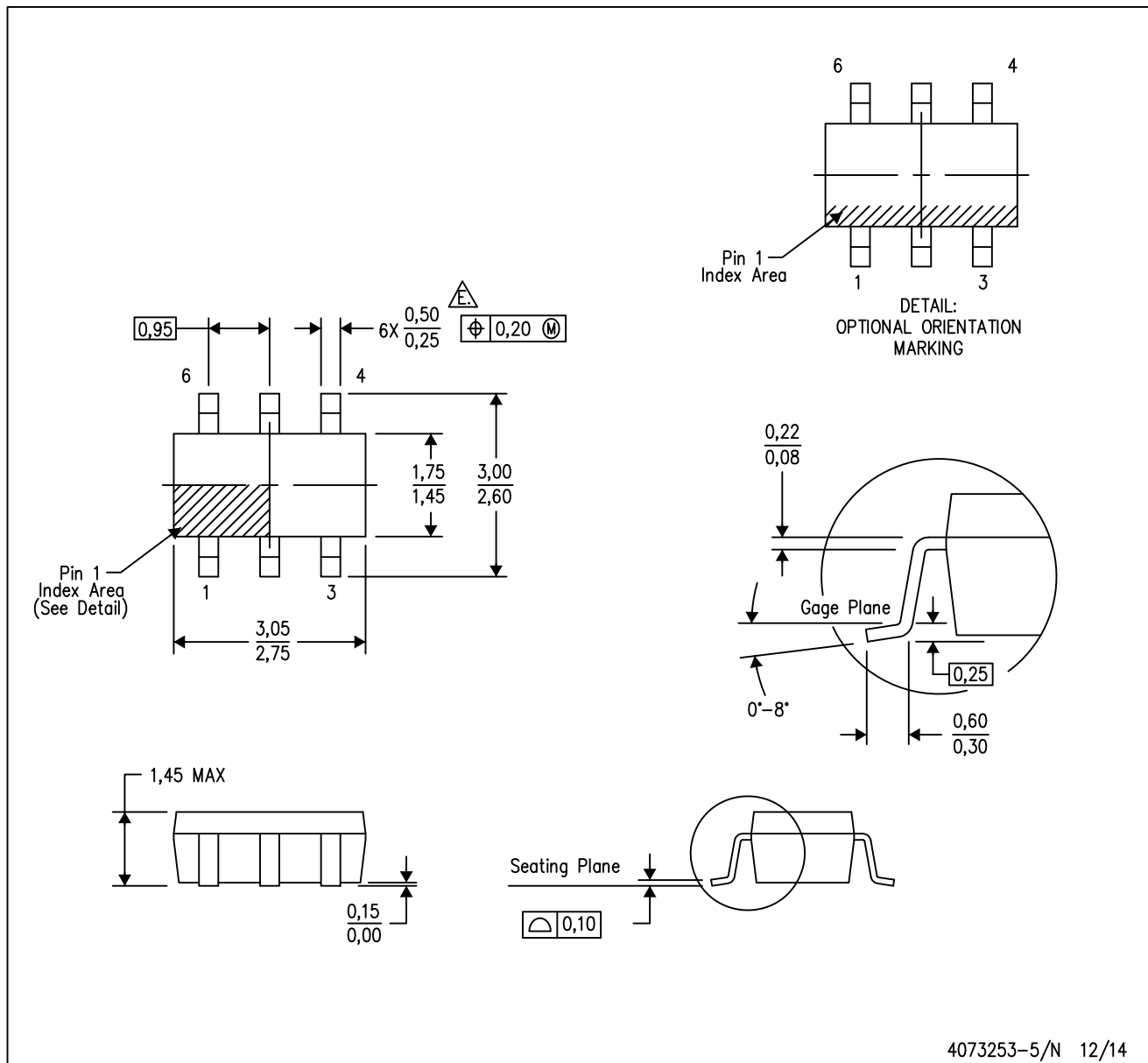

- NOTES:
- A. All linear dimensions are in millimeters.
  - B. This drawing is subject to change without notice.
  - C. Body dimensions do not include mold flash or protrusion. Mold flash and protrusion shall not exceed 0.15 per side.
  - D. Leads 1,2,3 may be wider than leads 4,5,6 for package orientation.
- Falls within JEDEC MO-178 Variation AB, except minimum lead width.

DBV (R-PDSO-G6)

PLASTIC SMALL OUTLINE

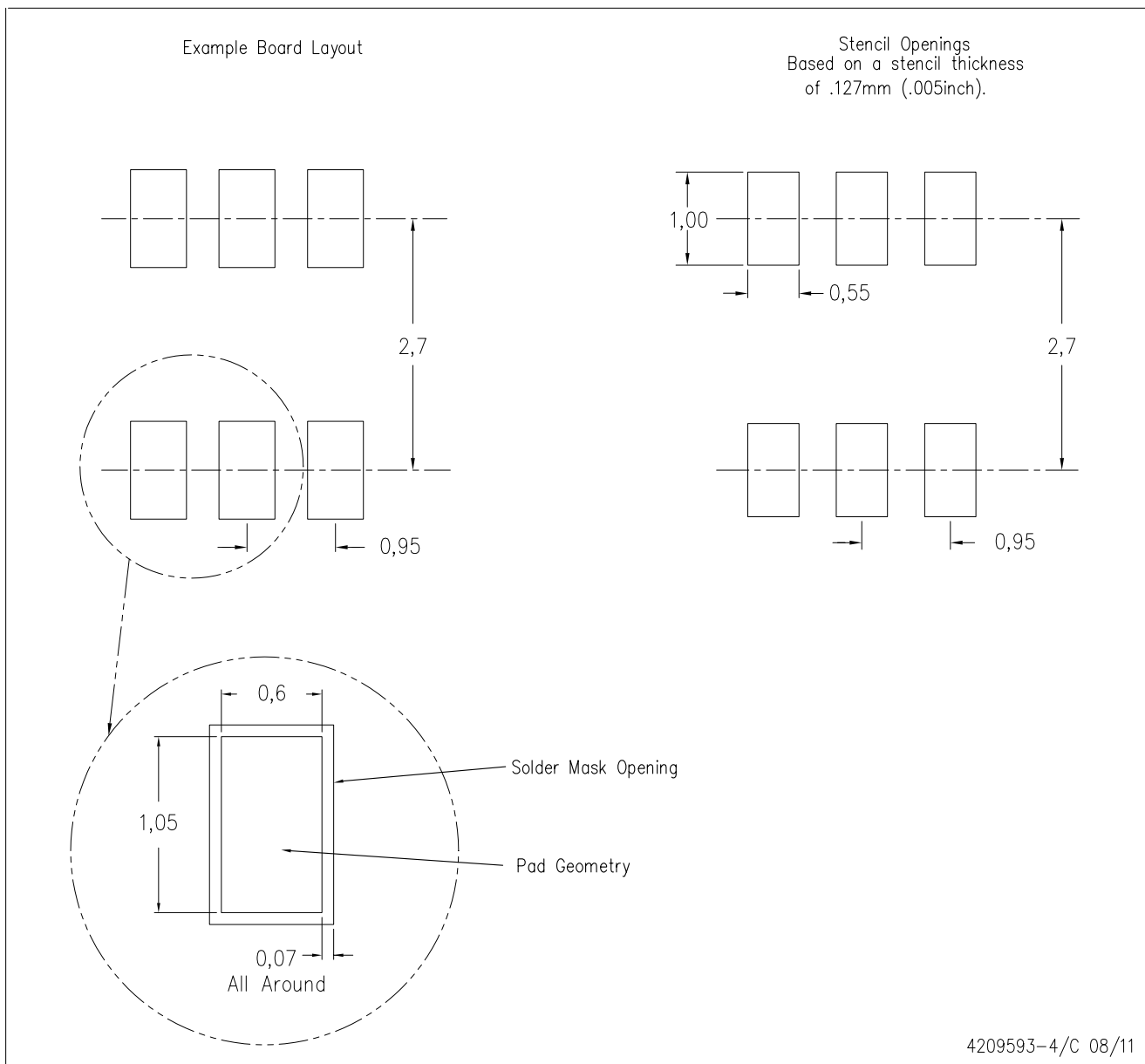

- NOTES:
- A. All linear dimensions are in millimeters.
  - B. This drawing is subject to change without notice.
  - C. Customers should place a note on the circuit board fabrication drawing not to alter the center solder mask defined pad.
  - D. Publication IPC-7351 is recommended for alternate designs.
  - E. Laser cutting apertures with trapezoidal walls and also rounding corners will offer better paste release. Customers should contact their board assembly site for stencil design recommendations. Example stencil design based on a 50% volumetric metal load solder paste. Refer to IPC-7525 for other stencil recommendations.

DRS (S-PWSON-N6)

PLASTIC SMALL OUTLINE NO-LEAD

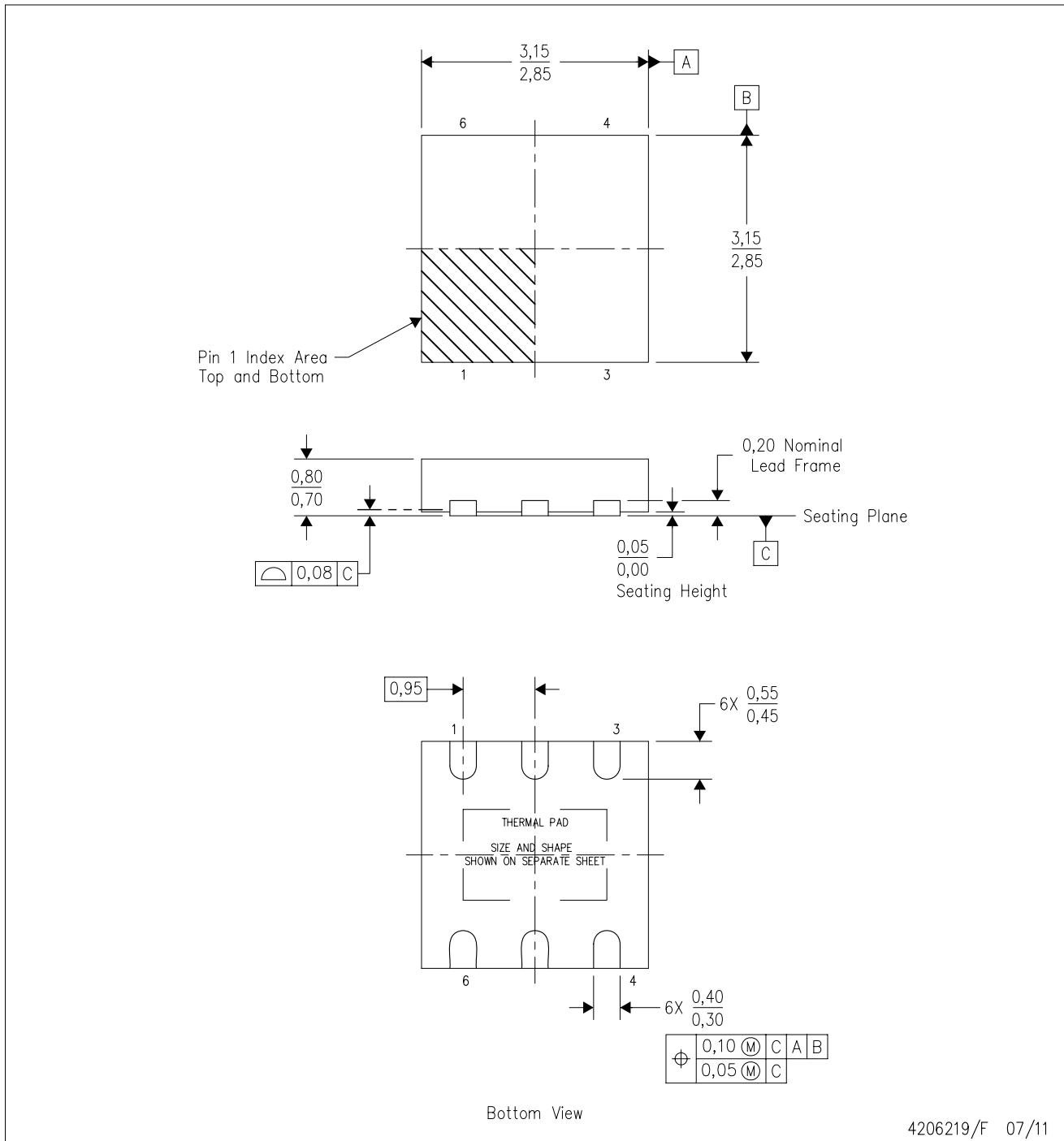

- NOTES:
- All linear dimensions are in millimeters. Dimensioning and tolerancing per ASME Y14.5M-1994.
  - This drawing is subject to change without notice.
  - SON (Small Outline No-Lead) package configuration.
  - The package thermal pad must be soldered to the board for thermal and mechanical performance.
  - See the additional figure in the Product Data Sheet for details regarding the exposed thermal pad features and dimensions.

## THERMAL PAD MECHANICAL DATA

DRS (S-PWSON-N6)

PLASTIC SMALL OUTLINE NO-LEAD

### THERMAL INFORMATION

This package incorporates an exposed thermal pad that is designed to be attached directly to an external heatsink. The thermal pad must be soldered directly to the printed circuit board (PCB). After soldering, the PCB can be used as a heatsink. In addition, through the use of thermal vias, the thermal pad can be attached directly to the appropriate copper plane shown in the electrical schematic for the device, or alternatively, can be attached to a special heatsink structure designed into the PCB. This design optimizes the heat transfer from the integrated circuit (IC).

For information on the Quad Flatpack No-Lead (QFN) package and its advantages, refer to Application Report, QFN/SON PCB Attachment, Texas Instruments Literature No. SLUA271. This document is available at [www.ti.com](http://www.ti.com).

The exposed thermal pad dimensions for this package are shown in the following illustration.

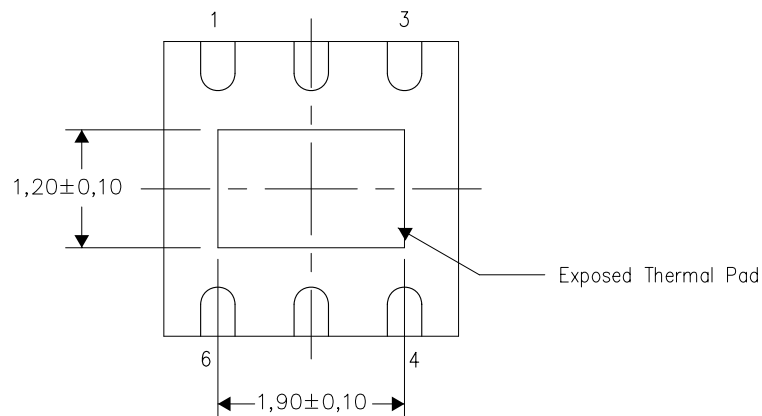

Bottom View

Exposed Thermal Pad Dimensions

4207663/E 07/11

NOTE: All linear dimensions are in millimeters

DRS (S-PWSON-N6)

PLASTIC SMALL OUTLINE NO-LEAD

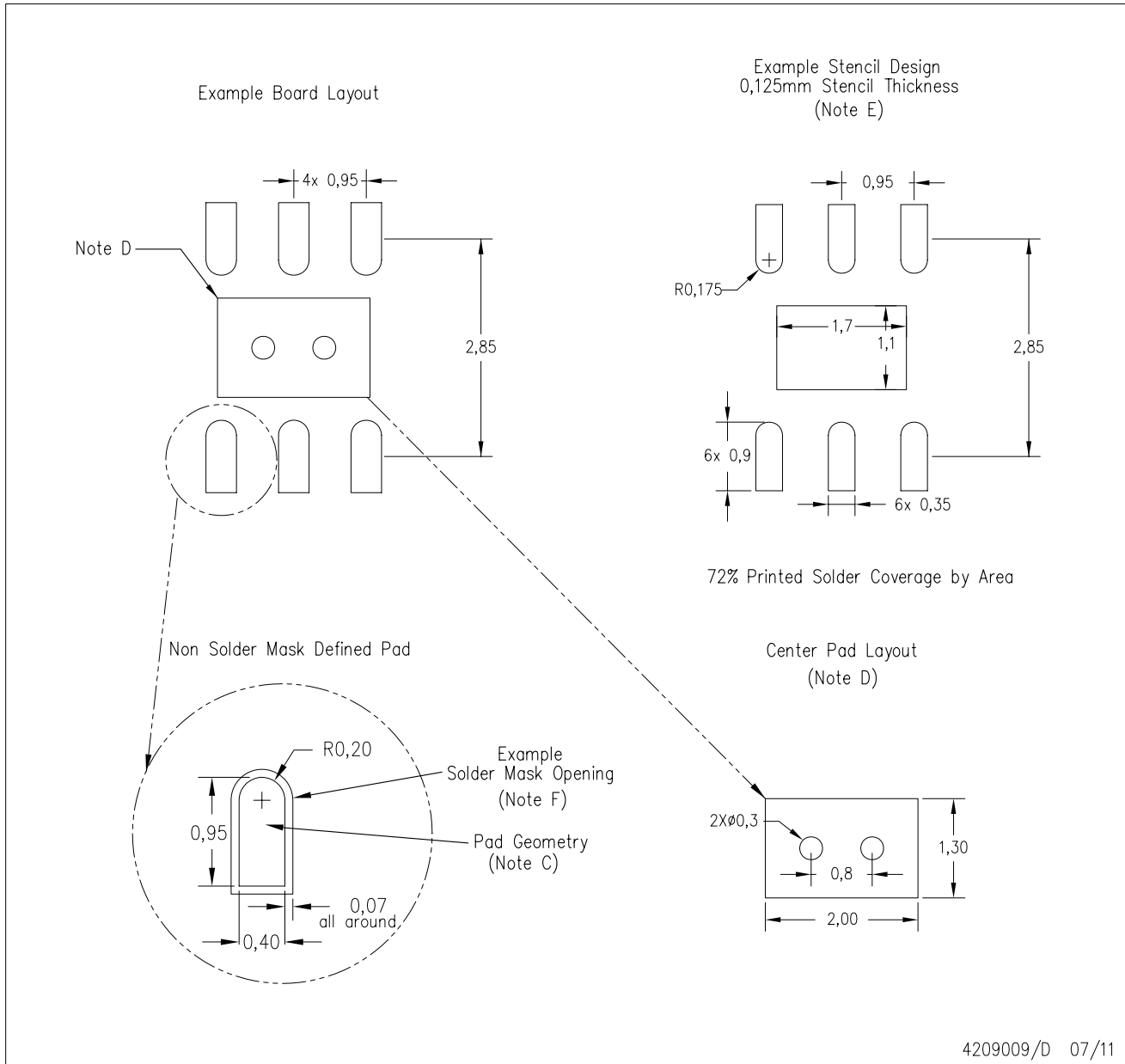

- NOTES:
- All linear dimensions are in millimeters.
  - This drawing is subject to change without notice.
  - Publication IPC-7351 is recommended for alternate designs.
  - This package is designed to be soldered to a thermal pad on the board. Refer to Application Note, QFN/SON PCB Attachment, Texas Instruments Literature No. SLUA271, and also the Product Data Sheets for specific thermal information, via requirements, and recommended board layout. These documents are available at [www.ti.com](http://www.ti.com) <<http://www.ti.com>>.
  - Laser cutting apertures with trapezoidal walls and also rounding corners will offer better paste release. Customers should contact their board assembly site for stencil design recommendations. Refer to IPC 7525 for stencil design considerations.
  - Customers should contact their board fabrication site for solder mask tolerances.

## 重要声明

德州仪器(TI) 及其下属子公司有权根据 JESD46 最新标准, 对所提供的产品和服务进行更正、修改、增强、改进或其它更改, 并有权根据 JESD48 最新标准中止提供任何产品和服务。客户在下订单前应获取最新的相关信息, 并验证这些信息是否完整且是最新的。所有产品的销售都遵循在订单确认时所提供的TI 销售条款与条件。

TI 保证其所销售的组件的性能符合产品销售时 TI 半导体产品销售条件与条款的适用规范。仅在 TI 保证的范围内, 且 TI 认为有必要时才会使用测试或其它质量控制技术。除非适用法律做出了硬性规定, 否则没有必要对每种组件的所有参数进行测试。

TI 对应用帮助或客户产品设计不承担任何义务。客户应对其使用 TI 组件的产品和应用自行负责。为尽量减小与客户产品和应用相关的风险, 客户应提供充分的设计与操作安全措施。

TI 不对任何 TI 专利权、版权、屏蔽作品权或其它与使用了 TI 组件或服务的组合设备、机器或流程相关的 TI 知识产权中授予的直接或间接版权限作出任何保证或解释。TI 所发布的与第三方产品或服务有关的信息, 不能构成从 TI 获得使用这些产品或服务的许可、授权、或认可。使用此类信息可能需要获得第三方的专利权或其它知识产权方面的许可, 或是 TI 的专利权或其它知识产权方面的许可。

对于 TI 的产品手册或数据表中 TI 信息的重要部分, 仅在没有对内容进行任何篡改且带有相关授权、条件、限制和声明的情况下才允许进行复制。TI 对此类篡改过的文件不承担任何责任或义务。复制第三方的信息可能需要服从额外的限制条件。

在转售 TI 组件或服务时, 如果对该组件或服务参数的陈述与 TI 标明的参数相比存在差异或虚假成分, 则会失去相关 TI 组件或服务的所有明示或暗示授权, 且这是不正当的、欺诈性商业行为。TI 对任何此类虚假陈述均不承担任何责任或义务。

客户认可并同意, 尽管任何应用相关信息或支持仍可能由 TI 提供, 但他们将独自负责满足与其产品及其应用中使用 TI 产品相关的所有法律、法规和安全相关要求。客户声明并同意, 他们具备制定与实施安全措施所需的全部专业技术和知识, 可预见故障的危险后果、监测故障及其后果、降低有可能造成人身伤害的故障的发生机率并采取适当的补救措施。客户将全额赔偿因在此类安全关键应用中使用任何 TI 组件而对 TI 及其代理造成的任何损失。

在某些场合中, 为了推进安全相关应用有可能对 TI 组件进行特别的促销。TI 的目标是利用此类组件帮助客户设计和创立其特有的可满足适用的功能安全性标准和要求的终端产品解决方案。尽管如此, 此类组件仍然服从这些条款。

TI 组件未获得用于 FDA Class III (或类似的生命攸关医疗设备) 的授权许可, 除非各方授权官员已经达成了专门管控此类使用的特别协议。

只有那些 TI 特别注明属于军用等级或“增强型塑料”的 TI 组件才是设计或专门用于军事/航空应用或环境的。购买者认可并同意, 对并非指定面向军事或航空航天用途的 TI 组件进行军事或航空航天方面的应用, 其风险由客户单独承担, 并且由客户独自负责满足与此类使用相关的所有法律和法规要求。

TI 已明确指定符合 ISO/TS16949 要求的产品, 这些产品主要用于汽车。在任何情况下, 因使用非指定产品而无法达到 ISO/TS16949 要求, TI 不承担任何责任。

	产品		应用
数字音频	<a href="http://www.ti.com.cn/audio">www.ti.com.cn/audio</a>	通信与电信	<a href="http://www.ti.com.cn/telecom">www.ti.com.cn/telecom</a>
放大器和线性器件	<a href="http://www.ti.com.cn/amplifiers">www.ti.com.cn/amplifiers</a>	计算机及周边	<a href="http://www.ti.com.cn/computer">www.ti.com.cn/computer</a>
数据转换器	<a href="http://www.ti.com.cn/dataconverters">www.ti.com.cn/dataconverters</a>	消费电子	<a href="http://www.ti.com.cn/consumer-apps">www.ti.com.cn/consumer-apps</a>
DLP® 产品	<a href="http://www.dlp.com">www.dlp.com</a>	能源	<a href="http://www.ti.com.cn/energy">www.ti.com.cn/energy</a>
DSP - 数字信号处理器	<a href="http://www.ti.com.cn/dsp">www.ti.com.cn/dsp</a>	工业应用	<a href="http://www.ti.com.cn/industrial">www.ti.com.cn/industrial</a>
时钟和计时器	<a href="http://www.ti.com.cn/clockandtimers">www.ti.com.cn/clockandtimers</a>	医疗电子	<a href="http://www.ti.com.cn/medical">www.ti.com.cn/medical</a>
接口	<a href="http://www.ti.com.cn/interface">www.ti.com.cn/interface</a>	安防应用	<a href="http://www.ti.com.cn/security">www.ti.com.cn/security</a>
逻辑	<a href="http://www.ti.com.cn/logic">www.ti.com.cn/logic</a>	汽车电子	<a href="http://www.ti.com.cn/automotive">www.ti.com.cn/automotive</a>
电源管理	<a href="http://www.ti.com.cn/power">www.ti.com.cn/power</a>	视频和影像	<a href="http://www.ti.com.cn/video">www.ti.com.cn/video</a>
微控制器 (MCU)	<a href="http://www.ti.com.cn/microcontrollers">www.ti.com.cn/microcontrollers</a>		
RFID 系统	<a href="http://www.ti.com.cn/rfidsys">www.ti.com.cn/rfidsys</a>		
OMAP应用处理器	<a href="http://www.ti.com.cn/omap">www.ti.com.cn/omap</a>		
无线连通性	<a href="http://www.ti.com.cn/wirelessconnectivity">www.ti.com.cn/wirelessconnectivity</a>	德州仪器在线技术支持社区	<a href="http://www.deyisupport.com">www.deyisupport.com</a>

Mailing Address: Texas Instruments, Post Office Box 655303, Dallas, Texas 75265  
Copyright © 2016, Texas Instruments Incorporated