

## 120-V Boot, 4-A Peak, High Frequency High-Side/Low-Side Driver

Check for Samples: [UCC27210](#), [UCC27211](#)

### FEATURES

- Drives Two N-Channel MOSFETs in High-Side/Low-Side Configuration with Independent Inputs
- Maximum Boot Voltage 120-V DC
- 4-A Sink, 4-A Source Output Currents
- 0.9- $\Omega$  Pull-Up/Pull-Down Resistance
- Input Pins can Tolerate -10 V to 20 V and are Independent of Supply Voltage Range
- TTL or Pseudo-CMOS Compatible Input Versions
- 8-V to 17-V VDD Operating Range, (20 V ABS MAX)
- 7.2-ns Rise and 5.5-ns Fall Time with 1000-pF Load
- Fast Propagation Delay Times (18 ns typical)
- 2-ns Delay Matching
- Symmetrical Under Voltage Lockout for High-Side and Low-Side Driver
- All Industry Standard Packages Available (SOIC-8, PowerPAD™ SOIC-8, 4-mm x 4-mm SON-8 and 4-mm x 4-mm SON-10)
- Specified from -40 to 140 °C

### APPLICATIONS

- Power Supplies for Telecom, Datacom, and Merchant
- Half-Bridge and Full-Bridge Converters
- Push-Pull Converters
- High Voltage Synchronous-Buck Converters
- Two-Switch Forward Converters
- Active-Clamp Forward Converters
- Class-D Audio Amplifiers

### DESCRIPTION

The UCC27210 and UCC27211 Drivers are based on the popular UCC27200 and UCC27201 MOSFET drivers, but offer several significant performance improvements. Peak output pull-up and pull-down current has been increased to 4-A source/4-A sink, and pull-up/pull-down resistance have been reduced to 0.9  $\Omega$ , thereby allowing for driving large power MOSFETs with minimized switching losses during the transition through the MOSFET's Miller Plateau. The input structure is now able to directly handle -10 VDC, which increases robustness and also allows direct interface to gate-drive transformers without using rectification diodes. The inputs are also independent of supply voltage and have a 20-V maximum rating.



Please be aware that an important notice concerning availability, standard warranty, and use in critical applications of Texas Instruments semiconductor products and disclaimers thereto appears at the end of this data sheet.

PowerPAD is a trademark of Texas Instruments.



These devices have limited built-in ESD protection. The leads should be shorted together or the device placed in conductive foam during storage or handling to prevent electrostatic damage to the MOS gates.

## DESCRIPTION (CONT.)

The UCC27210/1's switching node (HS pin) is able to handle -18 V maximum which allows the high-side channel to be protected from inherent negative voltages caused parasitic inductance and stray capacitance. The UCC27210 (Pseudo-CMOS inputs) and UCC27211 (TTL inputs) have increased hysteresis allowing for interface to analog or digital PWM controllers with enhanced noise immunity.

The low-side and high-side gate drivers are independently controlled and matched to 2 ns between the turn on and turn off of each other.

An on-chip 120-V rated bootstrap diode eliminates the external discrete diodes. Under-voltage lockout is provided for both the high-side and the low-side drivers providing symmetric turn-on/turn-off behavior and forcing the outputs low if the drive voltage is below the specified threshold.

Both devices are offered in 8-pin SOIC (D), PowerPAD™ SOIC-8 (DDA), 4-mm x 4-mm SON-8 (DRM) and SON-10 (DPR) packages.

## Typical Application Diagrams

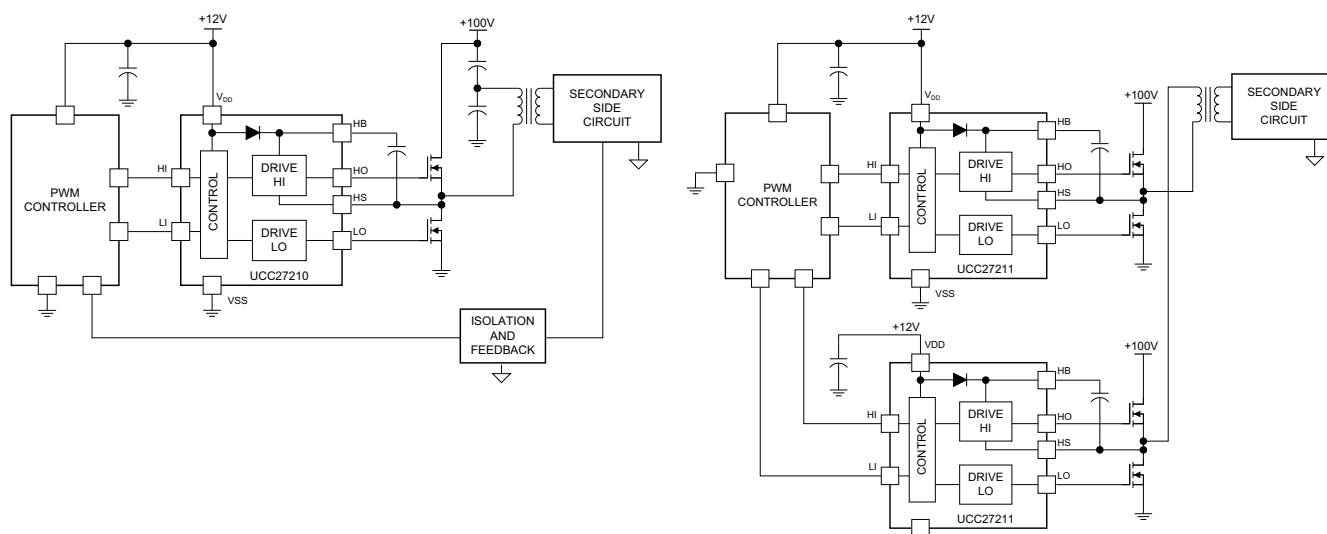

## ORDERING INFORMATION<sup>(1)</sup>

TEMPERATURE RANGE $T_A = T_J$	INPUT COMPATIBILITY	PACKAGED DEVICES <sup>(1)</sup>			
		SOIC-8 (D) <sup>(2)</sup>	PowerPAD™ SOIC-8 (DDA) <sup>(2)</sup>	SON-8 (DRM) <sup>(3)</sup>	SON-10 (DPR) <sup>(4)</sup>
-40°C to 140°C	Pseudo CMOS	UCC27210D	UCC27210DDA	UCC27210DRM	UCC27210DPR
	TTL	UCC27211D	UCC27211DDA	UCC27211DRM	UCC27211DPR

- (1) These products are packaged in Lead (Pb)-Free and green lead finish of PdNiAu which is compatible with MSL level 1 at 255°C to 260°C peak reflow temperature to be compatible with either lead free or Sn/Pb soldering operations.
- (2) D (SOIC-8) and DDA (Power Pad™ SOIC-8) packages are available taped and reeled. Add R suffix to device type (e.g. UCC27200ADR) to order quantities of 2,500 devices per reel.
- (3) DRM (SON-8) package comes either in a small reel of 250 pieces as part number UCC27200ADRMT, or larger reels of 3000 pieces as part number UCC27200A DRMR.
- (4) DPR (SON-10) package comes either in a small reel of 250 pieces as part number UCC27200ADPRT, or large reels pieces as part number UCC27200ADPRR.

## ABSOLUTE MAXIMUM RATINGS

over operating free-air temperature range (unless otherwise noted)

		MIN	MAX	UNIT
Supply voltage range, $V_{DD}^{(1)}$ , $V_{HB} - V_{HS}$		-0.3	20	V
Input voltages on LI and HI, $V_{LI}$ , $V_{HI}$		-10	20	
Output voltage on LO, $V_{LO}$	DC	-0.3	$V_{DD} + 0.3$	
	Repetitive pulse <100 ns <sup>(2)</sup>	-2	$V_{DD} + 0.3$	
Output voltage on HO, $V_{HO}$	DC	$V_{HS} - 0.3$	$V_{HB} + 0.3$	
	Repetitive pulse <100 ns <sup>(2)</sup>	$V_{HS} - 2$	$V_{HB} + 0.3$	
Voltage on HS, $V_{HS}$	DC	-1	115	
	Repetitive pulse <100 ns <sup>(2)</sup>	-18	115	
Voltage on HB, $V_{HB}$		-0.3	120	
ESD	Human Body Model (HBM)		2	
	Field Induced Charged Device Model (FICDM)		1	
Operating virtual junction temperature range, $T_J$		-40	150	°C
Storage temperature, $T_{STG}$		-65	150	
Lead temperature (soldering, 10 sec.)			300	

(1) All voltages are with respect to VSS unless otherwise noted. Currents are positive into, negative out of the specified terminal.

(2) Verified at bench characterization.

## RECOMMENDED OPERATING CONDITIONS

all voltages are with respect to  $V_{SS}$ ; currents are positive into and negative out of the specified terminal.  $-40^{\circ}\text{C} < T_J = T_A < 140^{\circ}\text{C}$  (unless otherwise noted)

PARAMETER	MIN	TYP	MAX	UNIT
Supply voltage range, $V_{DD}$ , $V_{HB}-V_{HS}$	8	12	17	V
Voltage on HS, $V_{HS}$	-1		105	
Voltage on HS, $V_{HS}$ (repetitive pulse <100 ns)	-15		110	
Voltage on HB, $V_{HB}$	$V_{HS} + 8$ , $V_{DD} - 1$		$V_{HS} + 17$ , 115	
Voltage slew rate on HS			50	V/ns
Operating junction temperature range	-40		140	°C

## THERMAL INFORMATION

THERMAL METRIC		UCC27210/11 <sup>(1)</sup>		UNITS
		D	DDA	
		8 PINS	8 PINS	
$\theta_{JA}$	Junction-to-ambient thermal resistance <sup>(2)</sup>	111.8	37.7	°C/W
$\theta_{JCTop}$	Junction-to-case (top) thermal resistance <sup>(3)</sup>	56.9	47.2	
$\theta_{JB}$	Junction-to-board thermal resistance <sup>(4)</sup>	53.0	9.6	
$\psi_{JT}$	Junction-to-top characterization parameter <sup>(5)</sup>	7.8	2.8	
$\psi_{JB}$	Junction-to-board characterization parameter <sup>(6)</sup>	52.3	9.4	
$\theta_{JCbott}$	Junction-to-case (bottom) thermal resistance <sup>(7)</sup>	n/a	3.6	

- (1) For more information about traditional and new thermal metrics, see the *IC Package Thermal Metrics* application report, [SPRA953](#).
- (2) The junction-to-ambient thermal resistance under natural convection is obtained in a simulation on a JEDEC-standard, high-K board, as specified in JESD51-7, in an environment described in JESD51-2a.
- (3) The junction-to-case (top) thermal resistance is obtained by simulating a cold plate test on the package top. No specific JEDEC-standard test exists, but a close description can be found in the ANSI SEMI standard G30-88.
- (4) The junction-to-board thermal resistance is obtained by simulating in an environment with a ring cold plate fixture to control the PCB temperature, as described in JESD51-8.
- (5) The junction-to-top characterization parameter,  $\psi_{JT}$ , estimates the junction temperature of a device in a real system and is extracted from the simulation data for obtaining  $\theta_{JA}$ , using a procedure described in JESD51-2a (sections 6 and 7).
- (6) The junction-to-board characterization parameter,  $\psi_{JB}$ , estimates the junction temperature of a device in a real system and is extracted from the simulation data for obtaining  $\theta_{JA}$ , using a procedure described in JESD51-2a (sections 6 and 7).
- (7) The junction-to-case (bottom) thermal resistance is obtained by simulating a cold plate test on the exposed (power) pad. No specific JEDEC standard test exists, but a close description can be found in the ANSI SEMI standard G30-88.

## THERMAL INFORMATION

THERMAL METRIC		UCC27210/11 <sup>(1)</sup>		UNITS
		DRM	DPR	
		8 PINS	10 PINS	
$\theta_{JA}$	Junction-to-ambient thermal resistance <sup>(2)</sup>	33.9	36.8	°C/W
$\theta_{JCTop}$	Junction-to-case (top) thermal resistance <sup>(3)</sup>	33.2	36.0	
$\theta_{JB}$	Junction-to-board thermal resistance <sup>(4)</sup>	11.4	14.0	
$\psi_{JT}$	Junction-to-top characterization parameter <sup>(5)</sup>	0.4	0.3	
$\psi_{JB}$	Junction-to-board characterization parameter <sup>(6)</sup>	11.7	14.2	
$\theta_{JCbott}$	Junction-to-case (bottom) thermal resistance <sup>(7)</sup>	2.3	3.4	

- (1) For more information about traditional and new thermal metrics, see the *IC Package Thermal Metrics* application report, [SPRA953](#).
- (2) The junction-to-ambient thermal resistance under natural convection is obtained in a simulation on a JEDEC-standard, high-K board, as specified in JESD51-7, in an environment described in JESD51-2a.
- (3) The junction-to-case (top) thermal resistance is obtained by simulating a cold plate test on the package top. No specific JEDEC-standard test exists, but a close description can be found in the ANSI SEMI standard G30-88.
- (4) The junction-to-board thermal resistance is obtained by simulating in an environment with a ring cold plate fixture to control the PCB temperature, as described in JESD51-8.
- (5) The junction-to-top characterization parameter,  $\psi_{JT}$ , estimates the junction temperature of a device in a real system and is extracted from the simulation data for obtaining  $\theta_{JA}$ , using a procedure described in JESD51-2a (sections 6 and 7).
- (6) The junction-to-board characterization parameter,  $\psi_{JB}$ , estimates the junction temperature of a device in a real system and is extracted from the simulation data for obtaining  $\theta_{JA}$ , using a procedure described in JESD51-2a (sections 6 and 7).
- (7) The junction-to-case (bottom) thermal resistance is obtained by simulating a cold plate test on the exposed (power) pad. No specific JEDEC standard test exists, but a close description can be found in the ANSI SEMI standard G30-88.

## ELECTRICAL CHARACTERISTICS

$V_{DD} = V_{HB} = 12\text{ V}$ ,  $V_{HS} = V_{SS} = 0\text{ V}$ , no load on LO or HO,  $T_A = T_J = -40^\circ\text{C}$  to  $140^\circ\text{C}$ , (unless otherwise noted)

PARAMETER		TEST CONDITION	MIN	TYP	MAX	UNITS	
<b>Supply Currents</b>							
$I_{DD}$	$V_{DD}$ quiescent current	$V(\text{LI}) = V(\text{HI}) = 0\text{ V}$	0.05	0.085	0.17	mA	
$I_{DDO}$	$V_{DD}$ operating current	UCC27210	2.4	2.6	4.3		
		UCC27211	2.4	2.5	4.3		
$I_{HB}$	Boot voltage quiescent current	$V(\text{LI}) = V(\text{HI}) = 0\text{ V}$	0.015	0.065	0.1		
$I_{HBO}$	Boot voltage operating current	$f = 500\text{ kHz}$ , $C_{\text{LOAD}} = 0$	1.5	2.5	4		
$I_{HBS}$	HB to $V_{SS}$ quiescent current	$V(\text{HS}) = V(\text{HB}) = 115\text{ V}$		0.0005	0.13	$\mu\text{A}$	
$I_{HBSO}$	HB to $V_{SS}$ operating current	$f = 500\text{ kHz}$ , $C_{\text{LOAD}} = 0$		0.07	0.9	mA	
<b>Input</b>							
$V_{\text{HIT}}$	Input voltage threshold	UCC27210	4.2	5.0	5.8	V	
$V_{\text{LIT}}$	Input voltage threshold		2.4	3.2	4.0		
$V_{\text{IHYS}}$	Input voltage hysteresis		1.8				
$R_{\text{IN}}$	Input pulldown resistance		102				k $\Omega$
$V_{\text{HIT}}$	Input voltage threshold	UCC27211	1.9	2.3	2.7	V	
$V_{\text{LIT}}$	Input voltage threshold		1.3	1.6	1.9		
$V_{\text{IHYS}}$	Input voltage hysteresis		700				mV
$R_{\text{IN}}$	Input pulldown resistance		68				k $\Omega$
<b>Under-Voltage Lockout (UVLO)</b>							
$V_{\text{DDR}}$	$V_{DD}$ turn-on threshold		6.2	7.0	7.8	V	
$V_{\text{DDHYS}}$	Hysteresis			0.5			
$V_{\text{HBR}}$	$V_{HB}$ turn-on threshold		5.6	6.7	7.9		
$V_{\text{HBHYS}}$	Hysteresis			1.1			
<b>Bootstrap Diode</b>							
$V_F$	Low-current forward voltage	$I_{V_{DD-HB}} = 100\ \mu\text{A}$		0.65	0.8	V	
$V_{FI}$	High-current forward voltage	$I_{V_{DD-HB}} = 100\ \text{mA}$		0.85	0.95		
$R_D$	Dynamic resistance, $\Delta V_F/\Delta I$	$I_{V_{DD-HB}} = 100\ \text{mA}$ and $80\ \text{mA}$	0.3	0.5	0.85	$\Omega$	
<b>LO Gate Driver</b>							
$V_{\text{LOL}}$	Low-level output voltage	$I_{LO} = 100\ \text{mA}$	0.05	0.09	0.15	V	
$V_{\text{LOH}}$	High level output voltage	$I_{LO} = -100\ \text{mA}$ , $V_{\text{LOH}} = V_{DD} - V_{LO}$	0.1	0.16	0.27		
	Peak pull-up current <sup>(1)</sup>	$V_{LO} = 0\ \text{V}$		3.7		A	
	Peak pull-down current <sup>(1)</sup>	$V_{LO} = 12\ \text{V}$		4.5			
<b>HO GATE Driver</b>							
$V_{\text{HOL}}$	Low-level output voltage	$I_{HO} = 100\ \text{mA}$	0.05	0.09	0.15	V	
$V_{\text{HOH}}$	High-level output voltage	$I_{HO} = -100\ \text{mA}$ , $V_{\text{HOH}} = V_{HB} - V_{HO}$	0.1	0.16	0.27		
	Peak pull-up current <sup>(1)</sup>	$V_{HO} = 0\ \text{V}$		3.7		A	
	Peak pull-down current <sup>(1)</sup>	$V_{HO} = 12\ \text{V}$		4.5			

(1) Ensured by design.

**ELECTRICAL CHARACTERISTICS (continued)**

$V_{DD} = V_{HB} = 12\text{ V}$ ,  $V_{HS} = V_{SS} = 0\text{ V}$ , no load on LO or HO,  $T_A = T_J = -40^\circ\text{C}$  to  $140^\circ\text{C}$ , (unless otherwise noted)

PARAMETER		TEST CONDITION	MIN	TYP	MAX	UNITS	
<b>Switching Parameters: Propagation Delays</b>							
$T_{DLFF}$	$V_{LI}$ falling to $V_{LO}$ falling	UCC27210, $C_{LOAD} = 0$	17	21	37	ns	
$T_{DHFF}$	$V_{HI}$ falling to $V_{HO}$ falling		17	21	37		
$T_{DLRR}$	$V_{LI}$ rising to $V_{LO}$ rising		18	24	46		
$T_{DHRR}$	$V_{HI}$ rising to $V_{HO}$ rising		18	24	46		
$T_{DLFF}$	$V_{LI}$ falling to $V_{LO}$ falling	UCC27211, $C_{LOAD} = 0$	10	17	30		
$T_{DHFF}$	$V_{HI}$ falling to $V_{HO}$ falling		10	17	30		
$T_{DLRR}$	$V_{LI}$ rising to $V_{LO}$ rising		10	18	40		
$T_{DHRR}$	$V_{HI}$ rising to $V_{HO}$ rising		10	18	40		
<b>Switching Parameters: Delay Matching</b>							
$T_{MON}$	From HO OFF to LO ON	UCC27210	$T_J = 25^\circ\text{C}$		3	11	ns
			$T_J = -40^\circ\text{C}$ to $140^\circ\text{C}$		3	14	
$T_{MOFF}$	From LO OFF to HO ON		$T_J = 25^\circ\text{C}$		3	11	ns
			$T_J = -40^\circ\text{C}$ to $140^\circ\text{C}$		3	14	
$T_{MON}$	From HO OFF to LO ON	UCC27211	$T_J = 25^\circ\text{C}$		2	9.5	ns
			$T_J = -40^\circ\text{C}$ to $140^\circ\text{C}$		2	14	
$T_{MOFF}$	From LO OFF to HO ON		$T_J = 25^\circ\text{C}$		2	9.5	ns
			$T_J = -40^\circ\text{C}$ to $140^\circ\text{C}$		2	14	
<b>Switching Parameters: Output Rise and Fall Time</b>							
$t_R$	LO rise time	$C_{LOAD} = 1000\text{ pF}$ , from 10% to 90%			7.2	ns	
$t_R$	HO rise time				7.2		
$t_F$	LO fall time	$C_{LOAD} = 1000\text{ pF}$ , from 90% to 10%			5.5		
$t_F$	HO fall time				5.5		
$t_R$	LO, HO	$C_{LOAD} = 0.1\text{ }\mu\text{F}$ , (3 V to 9 V)			0.36	0.6	$\mu\text{s}$
$t_F$	LO, HO	$C_{LOAD} = 0.1\text{ }\mu\text{F}$ , (9 V to 3 V)			0.15	0.4	
<b>Switching Parameters: Miscellaneous</b>							
	Minimum input pulse width that changes the output				50	ns	
	Bootstrap diode turn-off time <sup>(2)(3)</sup>	$I_F = 20\text{ mA}$ , $I_{REV} = 0.5\text{ A}$ <sup>(4)</sup>			20		

(2) Ensured by design.

(3)  $I_F$ : Forward current applied to bootstrap diode,  $I_{REV}$ : Reverse current applied to bootstrap diode.

(4) Typical values for  $T_A = 25^\circ\text{C}$ .

Timing Diagrams

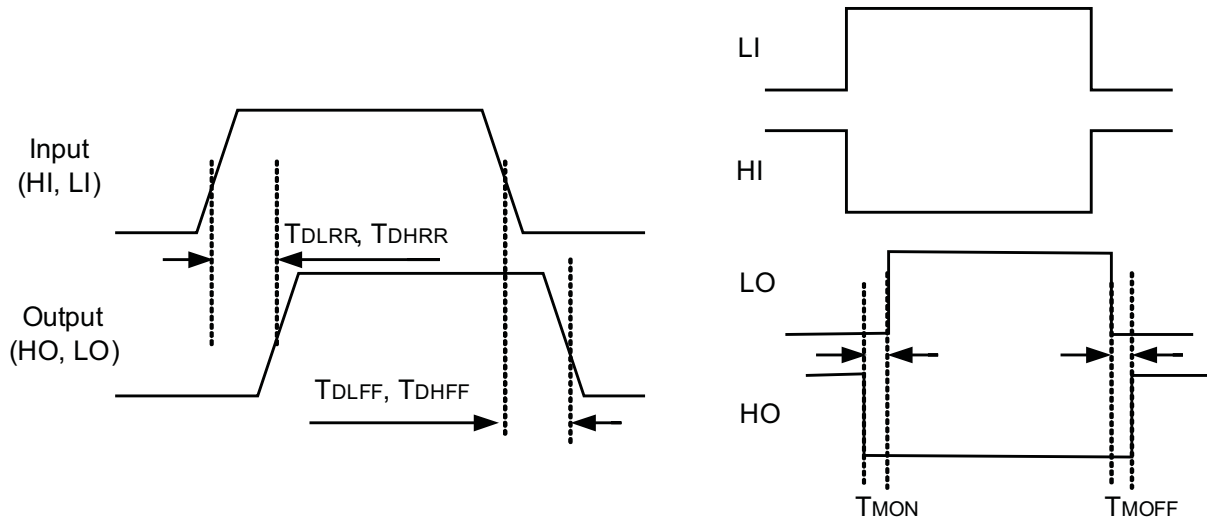

**DEVICE INFORMATION**

**Functional Block Diagram**

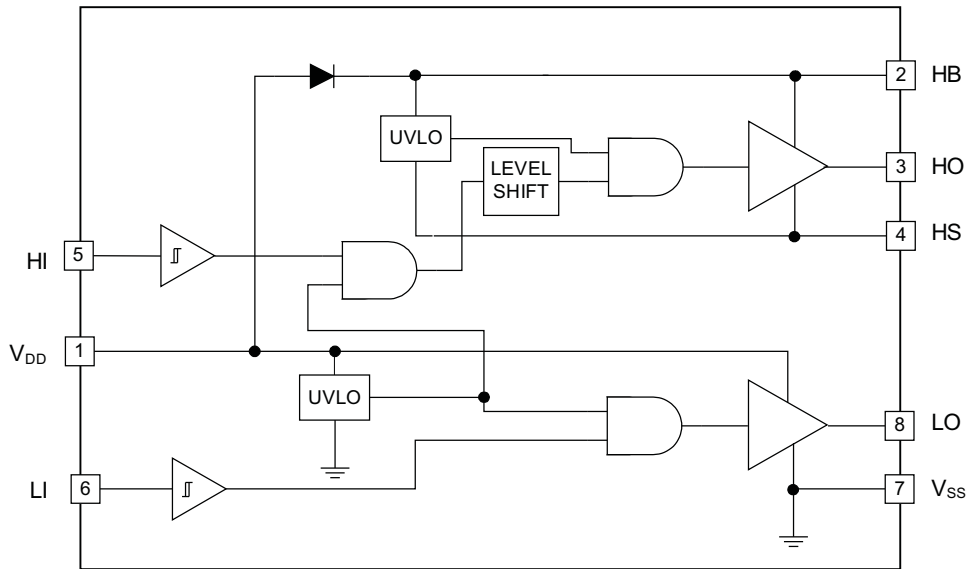

**SOIC-8 (D)**  
TOP VIEW

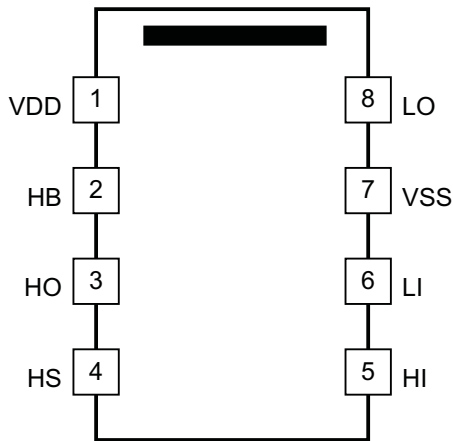

**Power Pad™ SOIC-8 (DDA)**  
TOP VIEW

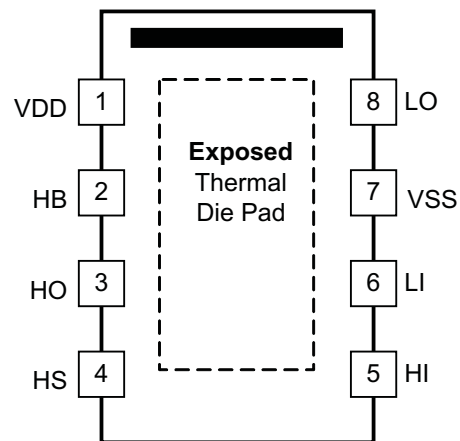

**SON-8 (DRM)**  
TOP VIEW

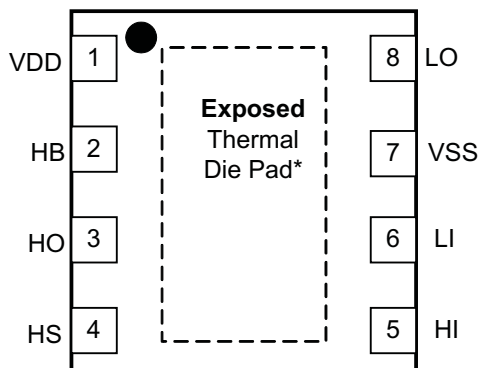

**SON-10 (DPR)**  
TOP VIEW

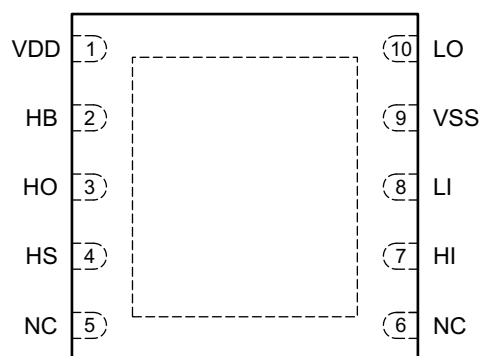

**TERMINAL FUNCTIONS**

PIN NAME	PIN		DESCRIPTION
	D/DDA/DRM	DPR	
VDD	1	1	Positive supply to the lower-gate driver. De-couple this pin to V <sub>SS</sub> (GND). Typical decoupling capacitor range is 0.22 $\mu$ F to 1.0 $\mu$ F.
HB	2	2	High-side bootstrap supply. The bootstrap diode is on-chip but the external bootstrap capacitor is required. Connect positive side of the bootstrap capacitor to this pin. Typical range of HB bypass capacitor is 0.022 $\mu$ F to 0.1 $\mu$ F. The capacitor value is dependant on the gate charge of the high-side MOSFET and should also be selected based on speed and ripple criteria
HO	3	3	High-side output. Connect to the gate of the high-side power MOSFET.
HS	4	4	High-side source connection. Connect to source of high-side power MOSFET. Connect the negative side of bootstrap capacitor to this pin.
HI	5	7	High-side input.
LI	6	8	Low-side input.
VSS	7	9	Negative supply terminal for the device which is generally grounded.
LO	8	10	Low-side output. Connect to the gate of the low-side power MOSFET.
N/C	-	5/6	Not Connected.
PowerPAD™ <sup>(1)</sup>	Pad	Pad	Utilized on the DDA, DRM and DPR packages only. Electrically referenced to V <sub>SS</sub> (GND). Connect to a large thermal mass trace or GND plane to dramatically improve thermal performance.

- (1) The PowerPAD™ is not directly connected to any leads of the package. However it is electrically and thermally connected to the substrate which is the ground of the device.

TYPICAL CHARACTERISTICS

QUIESCENT CURRENT  
vs  
SUPPLY VOLTAGE

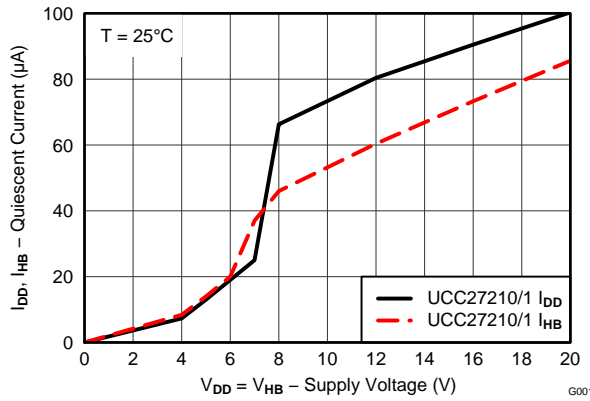

Figure 1.

UCC27210 IDD OPERATING CURRENT  
vs  
FREQUENCY

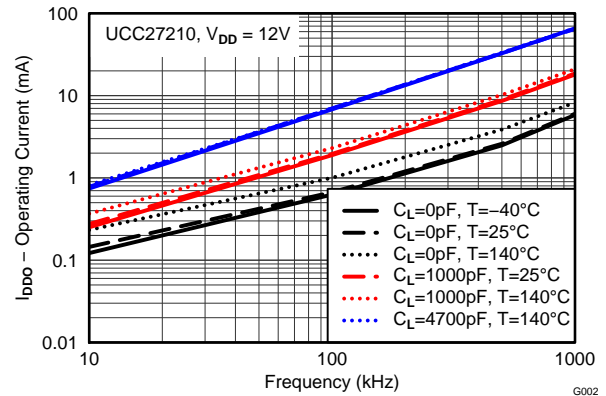

Figure 2.

UCC27211 IDD OPERATING CURRENT  
vs  
FREQUENCY

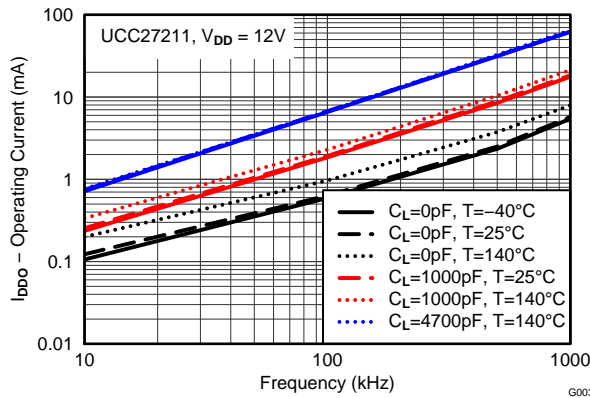

Figure 3.

BOOT VOLTAGE OPERATING CURRENT  
vs  
FREQUENCY (HB to HS)

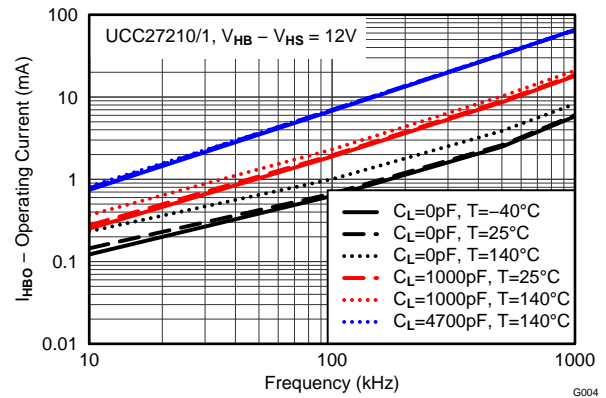

Figure 4.

UCC27210/11 INPUT THRESHOLD  
vs  
SUPPLY VOLTAGE

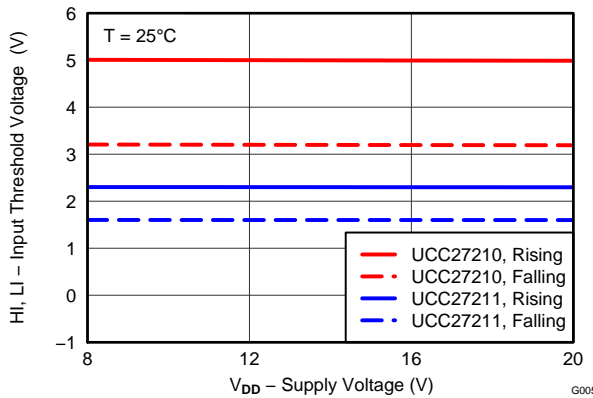

Figure 5.

UCC27210/11 INPUT THRESHOLDS  
vs  
TEMPERATURE

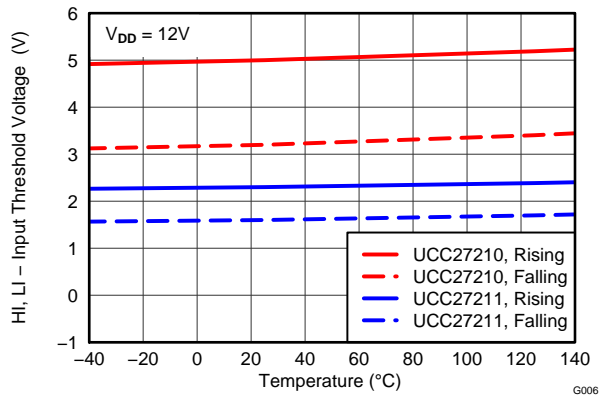

Figure 6.

**TYPICAL CHARACTERISTICS (continued)**

**LO AND HO HIGH LEVEL OUTPUT VOLTAGE vs TEMPERATURE**

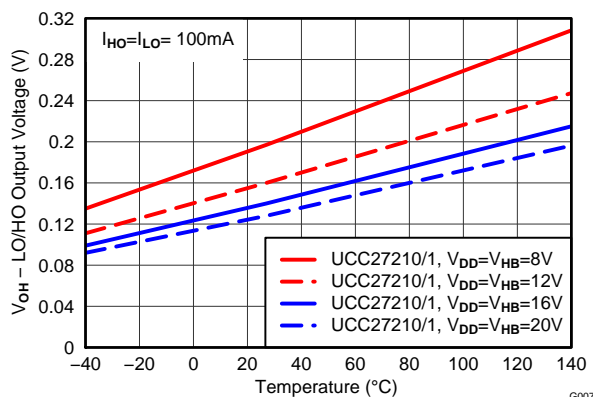

Figure 7.

**LO AND HO LOW LEVEL OUTPUT VOLTAGE vs TEMPERATURE**

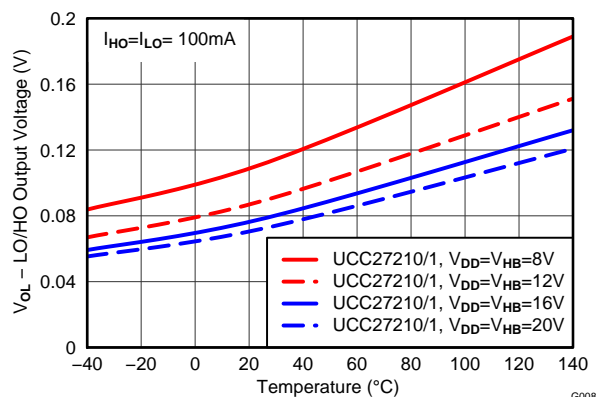

Figure 8.

**UNDERVOLTAGE LOCKOUT THRESHOLD vs TEMPERATURE**

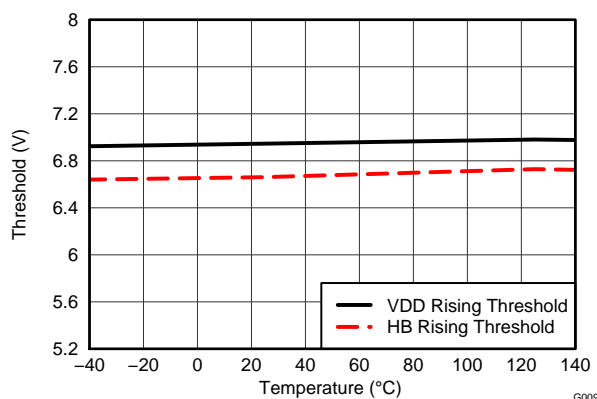

Figure 9.

**UNDERVOLTAGE LOCKOUT THRESHOLD Hysteresis vs TEMPERATURE**

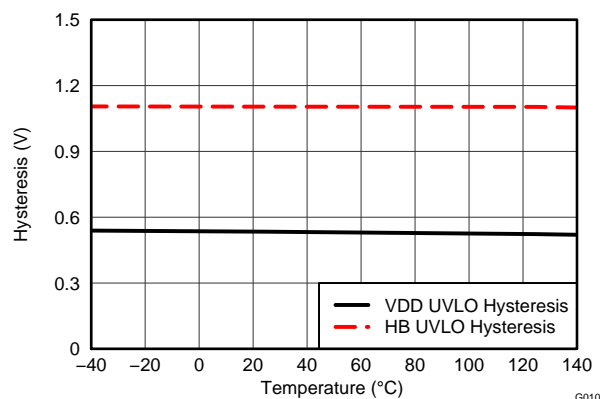

Figure 10.

**UCC27210 PROPAGATION DELAYS vs TEMPERATURE**

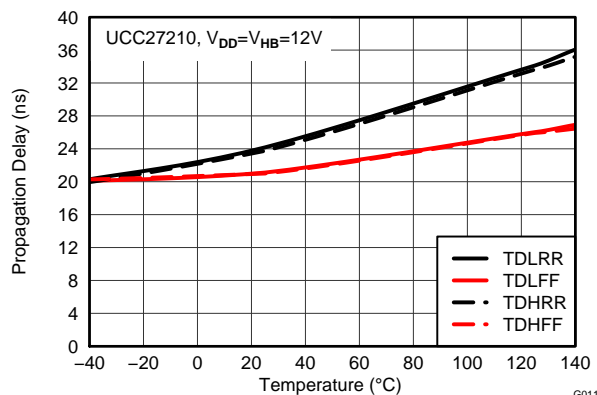

Figure 11.

**UCC27211 PROPAGATION DELAYS vs TEMPERATURE**

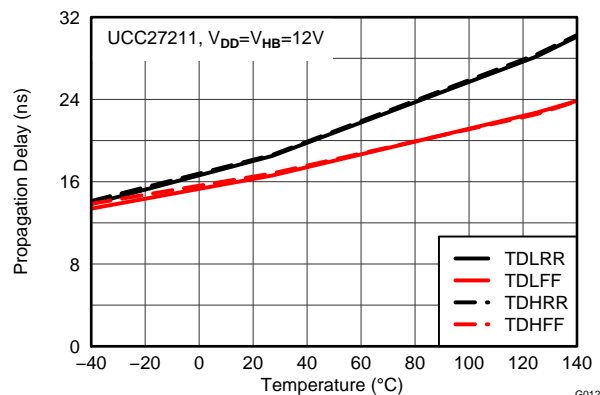
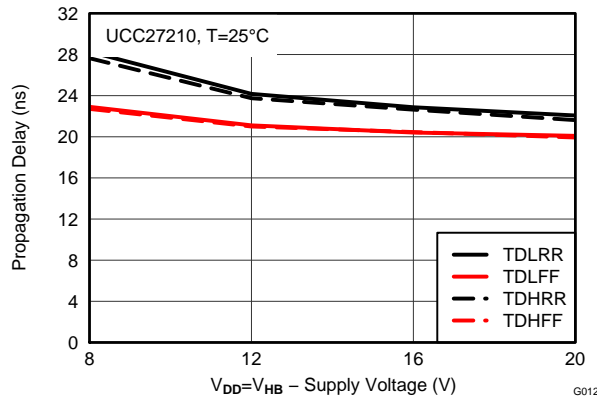

Figure 12.

**TYPICAL CHARACTERISTICS (continued)**

**UCC27210 PROPAGATION DELAYS**

**vs  
SUPPLY VOLTAGE**



**Figure 13.**

**UCC27211 PROPAGATION DELAYS**

**vs  
SUPPLY VOLTAGE**

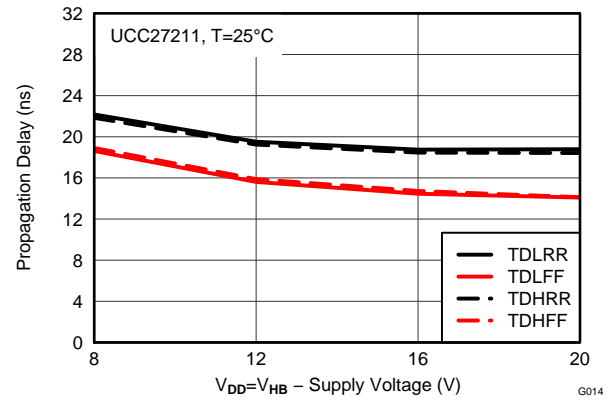

**Figure 14.**

**DELAY MATCHING**

**vs  
TEMPERATURE**

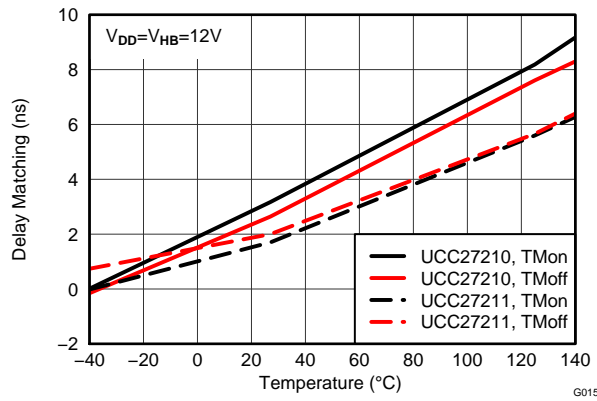

**Figure 15.**

**OUTPUT CURRENT**

**vs  
OUTPUT VOLTAGE**

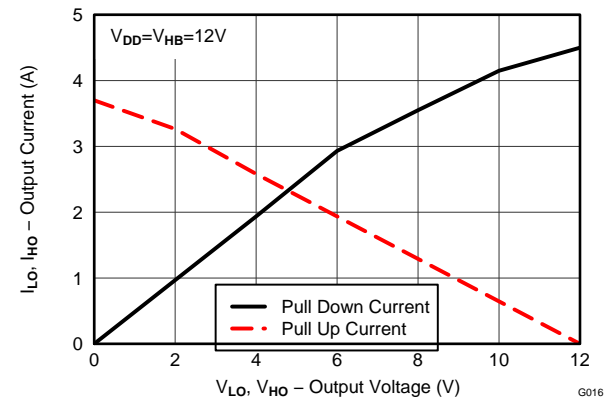

**Figure 16.**

TYPICAL CHARACTERISTICS (continued)

DIODE CURRENT  
vs  
DIODE VOLTAGE

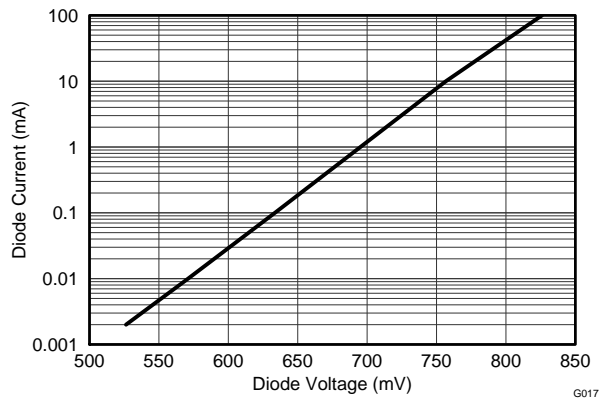

Figure 17.

NEGATIVE 10-V INPUT

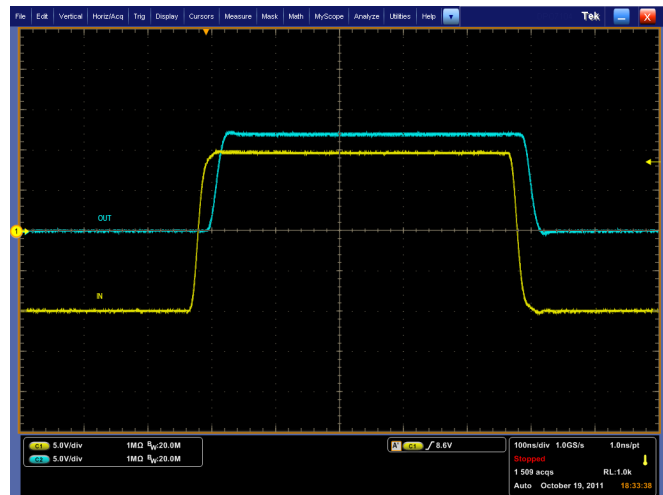

Figure 18.

STEP INPUT

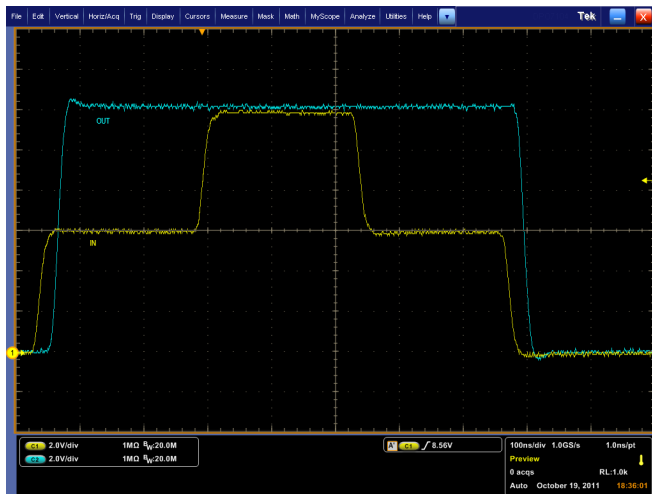

Figure 19.

SYMMETRICAL UVLO

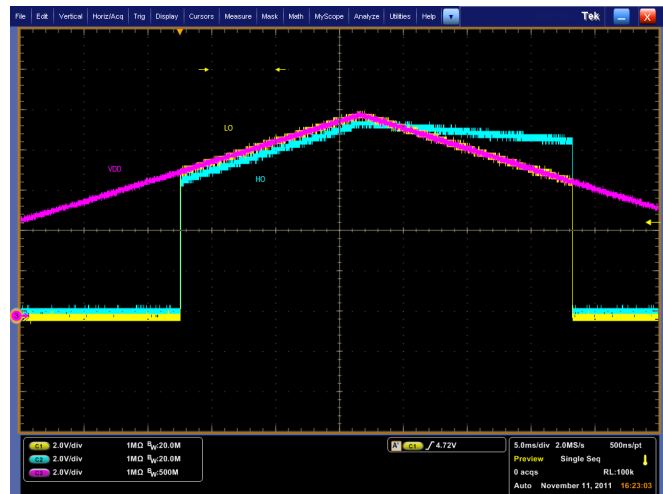

Figure 20.

## APPLICATION INFORMATION

### Functional Description

The UCC27210/11 represent Texas Instruments' latest generation of high voltage gate drivers which are designed to drive both the high-side and low-side of N-Channel MOSFETs in a half-/full-bridge or synchronous buck configuration. The floating high-side driver is capable of operating with supply voltages of up to 120 V. This allows for N-Channel MOSFET control in half-bridge, full-bridge, push pull, two-switch forward and active clamp forward converters.

The UCC27210/11 feature 4-A source/sink capability, industry best-in-class switching characteristics and a host of other features listed in the table below. These features combine to ensure efficient, robust and reliable operation in high-frequency switching power circuits.

**Table 1. UCC27210/11 Highlights**

FEATURE	BENEFIT
4-A source and sink current with 0.9-Ω output resistance	High peak current ideal for driving large power MOSFETs with minimal power loss (fast-drive capability at Miller plateau)
Input pins (HI and LI) can directly handle -10 VDC up to 20 VDC	Increased robustness and ability to handle under/overshoot. Can interface directly to gate-drive transformers without having to use rectification diodes
120-V internal boot diode	Provides voltage margin to meet telecom 100-V surge requirements
Switch node (HS pin) able to handle -18 V maximum for 100 ns	Allows the high-side channel to have extra protection from inherent negative voltages caused parasitic inductance and stray capacitance.
Robust ESD circuitry to handle voltage spikes	Excellent immunity to large dV/dT conditions
18-ns propagation delay with 7.2-ns / 5.5-ns rise/fall Times	Best-in-class switching characteristics and extremely low-pulse transmission distortion
2-ns (typ) delay matching between channels	Avoids transformer volt-second offset in bridge
Symmetrical UVLO circuit	Ensures high-side and low-side shut down at the same time
CMOS optimized threshold or TTL optimized thresholds with increased hysteresis	Complementary to analog or digital PWM controllers. Increased hysteresis offers added noise immunity

In UCC27210/11, the high side and low side each have independent inputs which allow maximum flexibility of input control signals in the application. The boot diode for the high-side driver bias supply is internal to the UCC27210 and UCC27211. The UCC27210 is the Pseudo-CMOS compatible input version and the UCC27211 is the TTL or logic compatible version. The high-side driver is referenced to the switch node (HS) which is typically the source pin of the high-side MOSFET and drain pin of the low-side MOSFET. The low-side driver is referenced to  $V_{SS}$  which is typically ground. The functions contained are the input stages, UVLO protection, level shift, boot diode, and output driver stages.

## Input Stages

The input stages provide the interface to the PWM output signals. The input impedance of the UCC27210 is 100 k $\Omega$  nominal and input capacitance is approximately 2 pF. The 100 k $\Omega$  is a pull-down resistance to  $V_{SS}$  (ground). The UCC27210 Pseudo-CMOS input structure has been designed to provide large hysteresis and at the same time to allow interfacing to a multitude of analog or digital PWM controllers. In some CMOS designs, the input thresholds are determined as a percentage of VDD. By doing so, the high-level input threshold can become unreasonably high and unusable. The UCC27210 recognizes the fact that VDD levels are trending downward and it therefore provides a rising threshold with 5.0 V (typ) and falling threshold with 3.2 V (typ). The input hysteresis of the UCC27210 is 1.8 V (typ).

The input stages of the UCC27211 have impedance of 70 k $\Omega$  nominal and input capacitance is approximately 2 pF. Pull-down resistance to  $V_{SS}$  (ground) is 70 k $\Omega$ . The logic level compatible input provides a rising threshold of 2.3 V and a falling threshold of 1.6 V.

## Under Voltage Lockout (UVLO)

The bias supplies for the high-side and low-side drivers have UVLO protection.  $V_{DD}$  as well as  $V_{HB}$  to  $V_{HS}$  differential voltages are monitored. The  $V_{DD}$  UVLO disables both drivers when  $V_{DD}$  is below the specified threshold. The rising  $V_{DD}$  threshold is 7.0 V with 0.5-V hysteresis. The VHB UVLO disables only the high-side driver when the  $V_{HB}$  to  $V_{HS}$  differential voltage is below the specified threshold. The  $V_{HB}$  UVLO rising threshold is 6.7 V with 1.1-V hysteresis.

## Level Shift

The level shift circuit is the interface from the high-side input to the high-side driver stage which is referenced to the switch node (HS). The level shift allows control of the HO output referenced to the HS pin and provides excellent delay matching with the low-side driver.

## Boot Diode

The boot diode necessary to generate the high-side bias is included in the UCC27210/11 family of drivers. The diode anode is connected to  $V_{DD}$  and cathode connected to  $V_{HB}$ . With the  $V_{HB}$  capacitor connected to HB and the HS pins, the  $V_{HB}$  capacitor charge is refreshed every switching cycle when HS transitions to ground. The boot diode provides fast recovery times, low diode resistance, and voltage rating margin to allow for efficient and reliable operation.

## Output Stages

The output stages are the interface to the power MOSFETs in the power train. High slew rate, low resistance and high peak current capability of both output drivers allow for efficient switching of the power MOSFETs. The low-side output stage is referenced from  $V_{DD}$  to  $V_{SS}$  and the high side is referenced from  $V_{HB}$  to  $V_{HS}$ .

## Layout Recommendations

To improve the switching characteristics and efficiency of a design, the following layout rules should be followed.

- Locate the driver as close as possible to the MOSFETs.
- Locate the  $V_{DD}$  and  $V_{HB}$  (bootstrap) capacitors as close as possible to the driver.
- Pay close attention to the GND trace. Use the thermal pad of the DDA and DRM package as GND by connecting it to the VSS pin (GND). The GND trace from the driver goes directly to the source of the MOSFET but should not be in the high current path of the MOSFET(S) drain or source current.
- Use similar rules for the HS node as for GND for the high-side driver.
- Use wide traces for LO and HO closely following the associated GND or HS traces. 60 to 100-mils width is preferable where possible.
- Use as least two or more vias if the driver outputs or SW node needs to be routed from one layer to another. For GND the number of vias needs to be a consideration of the thermal pad requirements as well as parasitic inductance.
- Avoid LI and HI (driver input) going close to the HS node or any other high  $dV/dT$  traces that can induce significant noise into the relatively high impedance leads.

Keep in mind that a poor layout can cause a significant drop in efficiency versus a good PCB layout and can even lead to decreased reliability of the whole system.

## Example Component Placement

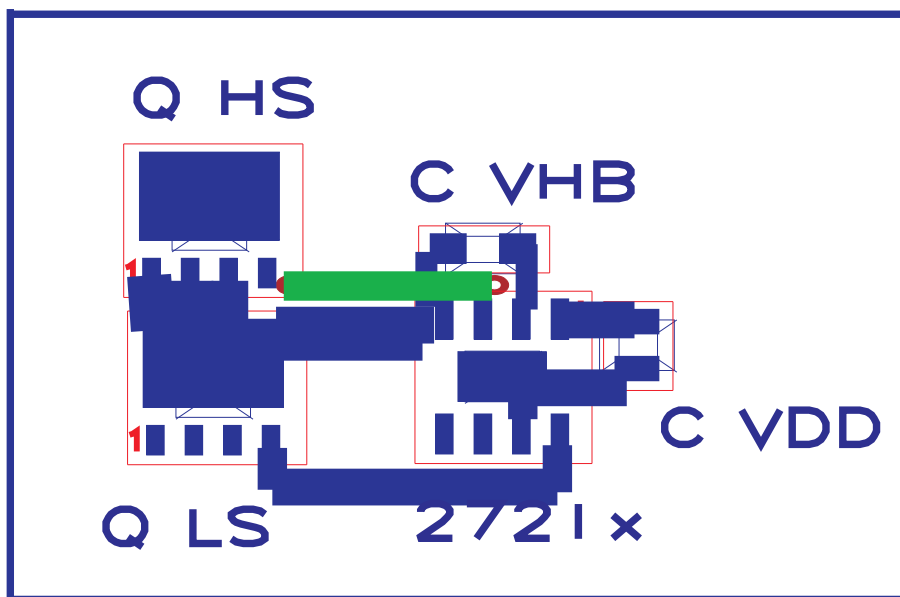

Figure 21. UCC27210/11 Component Placement

## Additional References

These references and links to additional information may be found at [www.ti.com](http://www.ti.com)

- Additional layout guidelines for PCB land patterns may be found in, *QFN/SON PCB Attachment*, Application Brief (Texas Instrument's Literature Number SLUA271)
- Additional thermal performance guidelines may be found in, *PowerPAD™ Thermally Enhanced Package Application Report*, Application Report (Texas Instrument's Literature Number SLMA002A)
- Additional thermal performance guidelines may be found in, *PowerPAD™ Made Easy*, Application Report (Texas Instrument's Literature Number SLMA004)

**PACKAGING INFORMATION**

Orderable Device	Status <sup>(1)</sup>	Package Type	Package Drawing	Pins	Package Qty	Eco Plan <sup>(2)</sup>	Lead/ Ball Finish	MSL Peak Temp <sup>(3)</sup>	Samples (Requires Login)
UCC27210D	ACTIVE	SOIC	D	8	75	Green (RoHS & no Sb/Br)	CU NIPDAU	Level-1-260C-UNLIM	
UCC27210DDA	PREVIEW	SO PowerPAD	DDA	8	75	Green (RoHS & no Sb/Br)	CU NIPDAUAG	Level-1-260C-UNLIM	
UCC27210DDAR	PREVIEW	SO PowerPAD	DDA	8	2500	Green (RoHS & no Sb/Br)	CU NIPDAUAG	Level-1-260C-UNLIM	
UCC27210DPRR	ACTIVE	WSON	DPR	10	3000	Green (RoHS & no Sb/Br)	CU NIPDAU	Level-2-260C-1 YEAR	
UCC27210DPRT	ACTIVE	WSON	DPR	10	250	Green (RoHS & no Sb/Br)	CU NIPDAU	Level-2-260C-1 YEAR	
UCC27210DR	ACTIVE	SOIC	D	8	2500	Green (RoHS & no Sb/Br)	CU NIPDAU	Level-1-260C-UNLIM	
UCC27210DRMR	ACTIVE	VSON	DRM	8	3000	Green (RoHS & no Sb/Br)	Call TI	Level-1-260C-UNLIM	
UCC27210DRMT	ACTIVE	VSON	DRM	8	250	Green (RoHS & no Sb/Br)	Call TI	Level-1-260C-UNLIM	
UCC27211D	ACTIVE	SOIC	D	8	75	Green (RoHS & no Sb/Br)	CU NIPDAU	Level-1-260C-UNLIM	
UCC27211DDA	PREVIEW	SO PowerPAD	DDA	8	75	Green (RoHS & no Sb/Br)	CU NIPDAUAG	Level-1-260C-UNLIM	
UCC27211DDAR	PREVIEW	SO PowerPAD	DDA	8	2500	Green (RoHS & no Sb/Br)	CU NIPDAUAG	Level-1-260C-UNLIM	
UCC27211DPRR	ACTIVE	WSON	DPR	10	3000	Green (RoHS & no Sb/Br)	CU NIPDAU	Level-2-260C-1 YEAR	
UCC27211DPRT	ACTIVE	WSON	DPR	10	250	Green (RoHS & no Sb/Br)	CU NIPDAU	Level-2-260C-1 YEAR	
UCC27211DR	ACTIVE	SOIC	D	8	2500	Green (RoHS & no Sb/Br)	CU NIPDAU	Level-1-260C-UNLIM	
UCC27211DRMR	ACTIVE	VSON	DRM	8	3000	Green (RoHS & no Sb/Br)	Call TI	Level-1-260C-UNLIM	
UCC27211DRMT	ACTIVE	VSON	DRM	8	250	Green (RoHS & no Sb/Br)	Call TI	Level-1-260C-UNLIM	

<sup>(1)</sup> The marketing status values are defined as follows:

---

**ACTIVE:** Product device recommended for new designs.

**LIFEBUY:** TI has announced that the device will be discontinued, and a lifetime-buy period is in effect.

**NRND:** Not recommended for new designs. Device is in production to support existing customers, but TI does not recommend using this part in a new design.

**PREVIEW:** Device has been announced but is not in production. Samples may or may not be available.

**OBSOLETE:** TI has discontinued the production of the device.

<sup>(2)</sup> Eco Plan - The planned eco-friendly classification: Pb-Free (RoHS), Pb-Free (RoHS Exempt), or Green (RoHS & no Sb/Br) - please check <http://www.ti.com/productcontent> for the latest availability information and additional product content details.

**TBD:** The Pb-Free/Green conversion plan has not been defined.

**Pb-Free (RoHS):** TI's terms "Lead-Free" or "Pb-Free" mean semiconductor products that are compatible with the current RoHS requirements for all 6 substances, including the requirement that lead not exceed 0.1% by weight in homogeneous materials. Where designed to be soldered at high temperatures, TI Pb-Free products are suitable for use in specified lead-free processes.

**Pb-Free (RoHS Exempt):** This component has a RoHS exemption for either 1) lead-based flip-chip solder bumps used between the die and package, or 2) lead-based die adhesive used between the die and leadframe. The component is otherwise considered Pb-Free (RoHS compatible) as defined above.

**Green (RoHS & no Sb/Br):** TI defines "Green" to mean Pb-Free (RoHS compatible), and free of Bromine (Br) and Antimony (Sb) based flame retardants (Br or Sb do not exceed 0.1% by weight in homogeneous material)

<sup>(3)</sup> MSL, Peak Temp. -- The Moisture Sensitivity Level rating according to the JEDEC industry standard classifications, and peak solder temperature.

**Important Information and Disclaimer:** The information provided on this page represents TI's knowledge and belief as of the date that it is provided. TI bases its knowledge and belief on information provided by third parties, and makes no representation or warranty as to the accuracy of such information. Efforts are underway to better integrate information from third parties. TI has taken and continues to take reasonable steps to provide representative and accurate information but may not have conducted destructive testing or chemical analysis on incoming materials and chemicals. TI and TI suppliers consider certain information to be proprietary, and thus CAS numbers and other limited information may not be available for release.

In no event shall TI's liability arising out of such information exceed the total purchase price of the TI part(s) at issue in this document sold by TI to Customer on an annual basis.

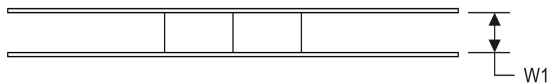
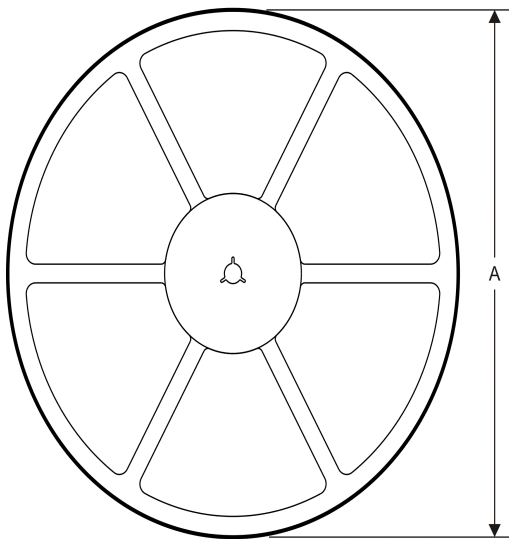
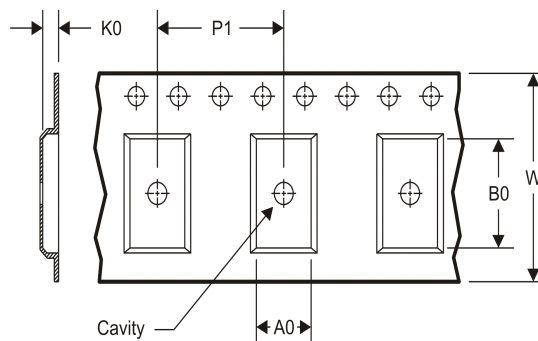
**TAPE AND REEL INFORMATION**
**REEL DIMENSIONS**

**TAPE DIMENSIONS**

A0	Dimension designed to accommodate the component width
B0	Dimension designed to accommodate the component length
K0	Dimension designed to accommodate the component thickness
W	Overall width of the carrier tape
P1	Pitch between successive cavity centers

**TAPE AND REEL INFORMATION**

\*All dimensions are nominal

Device	Package Type	Package Drawing	Pins	SPQ	Reel Diameter (mm)	Reel Width W1 (mm)	A0 (mm)	B0 (mm)	K0 (mm)	P1 (mm)	W (mm)	Pin1 Quadrant
UCC27210DPRR	WSO	DPR	10	3000	330.0	12.4	4.25	4.25	1.15	8.0	12.0	Q2
UCC27210DPRT	WSO	DPR	10	250	180.0	12.4	4.25	4.25	1.15	8.0	12.0	Q2
UCC27211DPRR	WSO	DPR	10	3000	330.0	12.4	4.25	4.25	1.15	8.0	12.0	Q2
UCC27211DPRT	WSO	DPR	10	250	180.0	12.4	4.25	4.25	1.15	8.0	12.0	Q2

**TAPE AND REEL BOX DIMENSIONS**

\*All dimensions are nominal

Device	Package Type	Package Drawing	Pins	SPQ	Length (mm)	Width (mm)	Height (mm)
UCC27210DPRR	WSON	DPR	10	3000	346.0	346.0	29.0
UCC27210DPRT	WSON	DPR	10	250	210.0	185.0	35.0
UCC27211DPRR	WSON	DPR	10	3000	346.0	346.0	29.0
UCC27211DPRT	WSON	DPR	10	250	210.0	185.0	35.0

DDA (R-PDSO-G8)

PowerPAD™ PLASTIC SMALL-OUTLINE

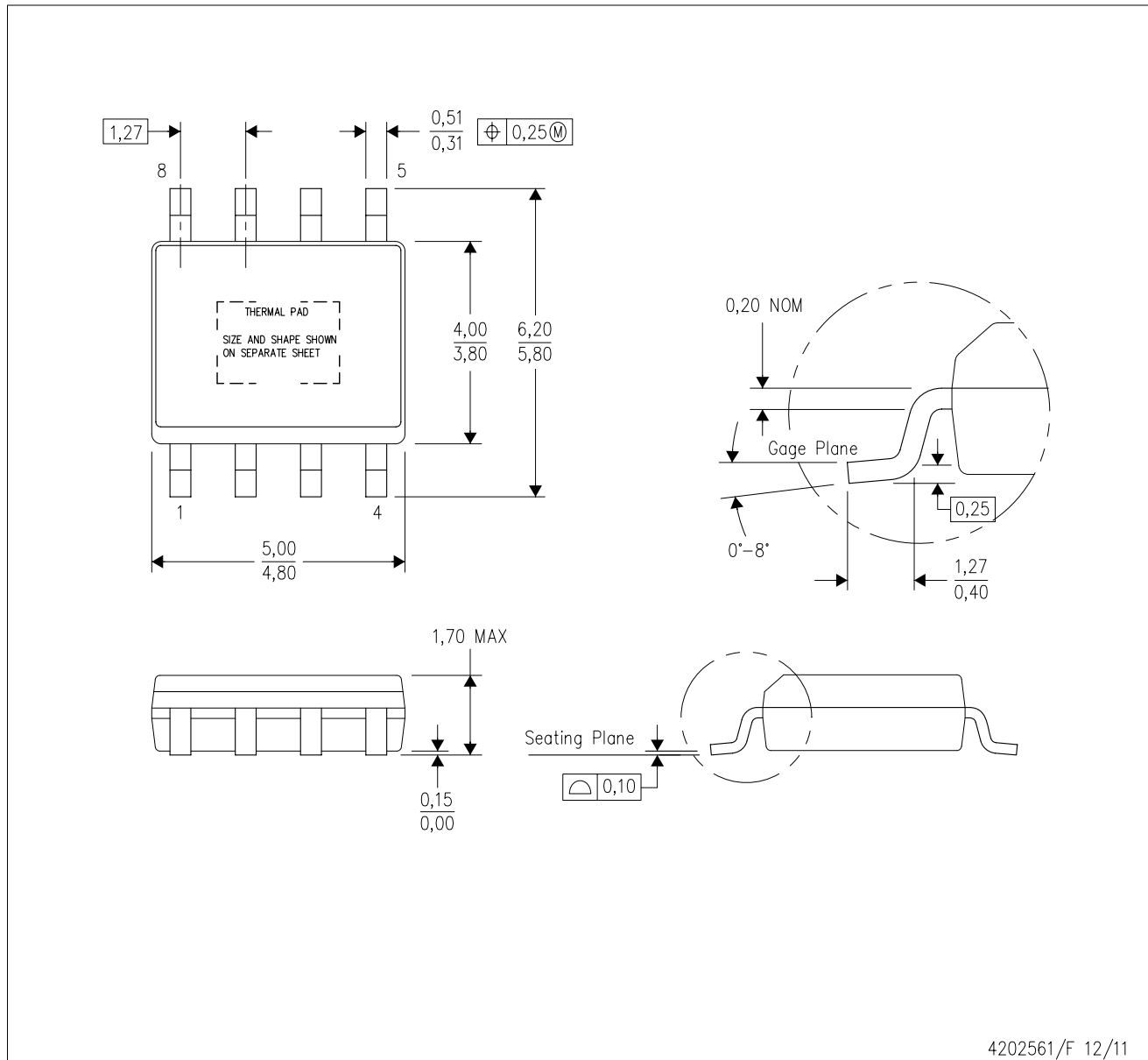

- NOTES:
- All linear dimensions are in millimeters. Dimensioning and tolerancing per ASME Y14.5-1994.
  - This drawing is subject to change without notice.
  - Body dimensions do not include mold flash or protrusion not to exceed 0,15.
  - This package is designed to be soldered to a thermal pad on the board. Refer to Technical Brief, PowerPad Thermally Enhanced Package, Texas Instruments Literature No. SLMA002 for information regarding recommended board layout. This document is available at [www.ti.com](http://www.ti.com) <<http://www.ti.com>>.
  - See the additional figure in the Product Data Sheet for details regarding the exposed thermal pad features and dimensions.
  - This package complies to JEDEC MS-012 variation BA

PowerPAD is a trademark of Texas Instruments.

DRM (S-PVSON-N8)

PLASTIC SMALL OUTLINE NO-LEAD

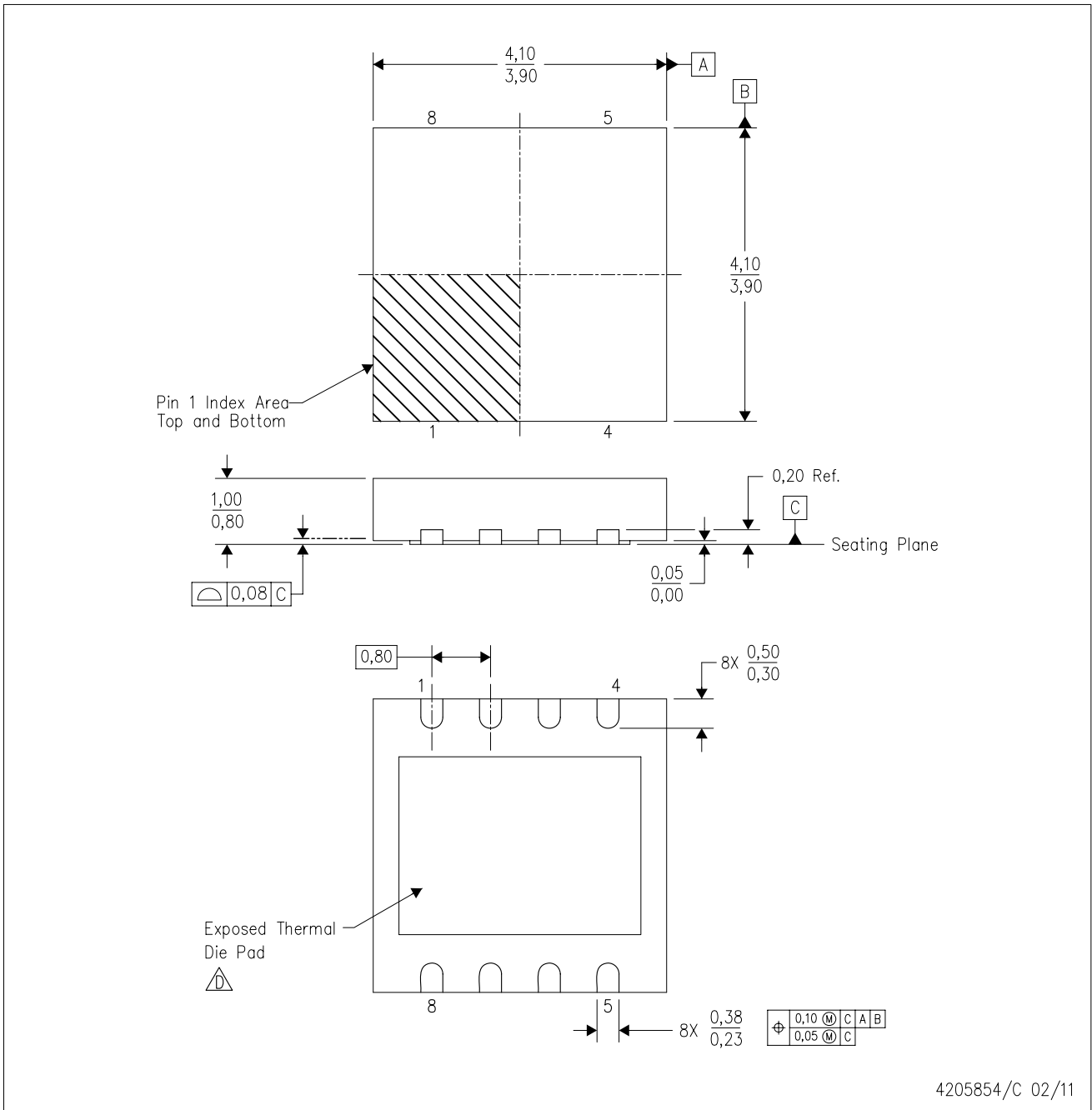

- NOTES:
- A. All linear dimensions are in millimeters. Dimensioning and tolerancing per ASME Y14.5M-1994.
  - B. This drawing is subject to change without notice.
  - C. SON (Small Outline No-Lead) package configuration.
  - The package thermal pad must be soldered to the board for thermal and mechanical performance. See the Product Data Sheet for details regarding the exposed thermal pad dimensions.

### THERMAL INFORMATION

This package incorporates an exposed thermal pad that is designed to be attached directly to an external heatsink. The thermal pad must be soldered directly to the printed circuit board (PCB). After soldering, the PCB can be used as a heatsink. In addition, through the use of thermal vias, the thermal pad can be attached directly to the appropriate copper plane shown in the electrical schematic for the device, or alternatively, can be attached to a special heatsink structure designed into the PCB. This design optimizes the heat transfer from the integrated circuit (IC).

For information on the Quad Flatpack No-Lead (QFN) package and its advantages, refer to Application Report, Quad Flatpack No-Lead Logic Packages, Texas Instruments Literature No. SCBA017. This document is available at [www.ti.com](http://www.ti.com).

The exposed thermal pad dimensions for this package are shown in the following illustration.

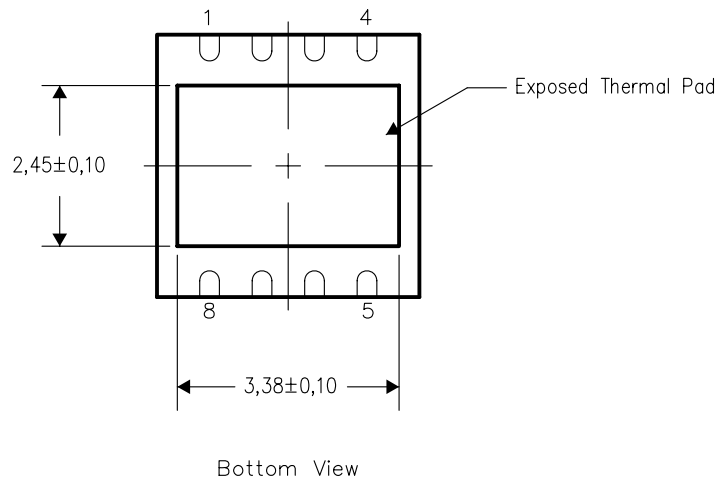

NOTE: All linear dimensions are in millimeters

Exposed Thermal Pad Dimensions



D (R-PDSO-G8)

PLASTIC SMALL OUTLINE



NOTES: A. All linear dimensions are in inches (millimeters).  
 B. This drawing is subject to change without notice.  
 C. Body length does not include mold flash, protrusions, or gate burrs. Mold flash, protrusions, or gate burrs shall not exceed 0.006 (0,15) each side.  
 D. Body width does not include interlead flash. Interlead flash shall not exceed 0.017 (0,43) each side.  
 E. Reference JEDEC MS-012 variation AA.

## IMPORTANT NOTICE

Texas Instruments Incorporated and its subsidiaries (TI) reserve the right to make corrections, modifications, enhancements, improvements, and other changes to its products and services at any time and to discontinue any product or service without notice. Customers should obtain the latest relevant information before placing orders and should verify that such information is current and complete. All products are sold subject to TI's terms and conditions of sale supplied at the time of order acknowledgment.

TI warrants performance of its hardware products to the specifications applicable at the time of sale in accordance with TI's standard warranty. Testing and other quality control techniques are used to the extent TI deems necessary to support this warranty. Except where mandated by government requirements, testing of all parameters of each product is not necessarily performed.

TI assumes no liability for applications assistance or customer product design. Customers are responsible for their products and applications using TI components. To minimize the risks associated with customer products and applications, customers should provide adequate design and operating safeguards.

TI does not warrant or represent that any license, either express or implied, is granted under any TI patent right, copyright, mask work right, or other TI intellectual property right relating to any combination, machine, or process in which TI products or services are used. Information published by TI regarding third-party products or services does not constitute a license from TI to use such products or services or a warranty or endorsement thereof. Use of such information may require a license from a third party under the patents or other intellectual property of the third party, or a license from TI under the patents or other intellectual property of TI.

Reproduction of TI information in TI data books or data sheets is permissible only if reproduction is without alteration and is accompanied by all associated warranties, conditions, limitations, and notices. Reproduction of this information with alteration is an unfair and deceptive business practice. TI is not responsible or liable for such altered documentation. Information of third parties may be subject to additional restrictions.

Resale of TI products or services with statements different from or beyond the parameters stated by TI for that product or service voids all express and any implied warranties for the associated TI product or service and is an unfair and deceptive business practice. TI is not responsible or liable for any such statements.

TI products are not authorized for use in safety-critical applications (such as life support) where a failure of the TI product would reasonably be expected to cause severe personal injury or death, unless officers of the parties have executed an agreement specifically governing such use. Buyers represent that they have all necessary expertise in the safety and regulatory ramifications of their applications, and acknowledge and agree that they are solely responsible for all legal, regulatory and safety-related requirements concerning their products and any use of TI products in such safety-critical applications, notwithstanding any applications-related information or support that may be provided by TI. Further, Buyers must fully indemnify TI and its representatives against any damages arising out of the use of TI products in such safety-critical applications.

TI products are neither designed nor intended for use in military/aerospace applications or environments unless the TI products are specifically designated by TI as military-grade or "enhanced plastic." Only products designated by TI as military-grade meet military specifications. Buyers acknowledge and agree that any such use of TI products which TI has not designated as military-grade is solely at the Buyer's risk, and that they are solely responsible for compliance with all legal and regulatory requirements in connection with such use.

TI products are neither designed nor intended for use in automotive applications or environments unless the specific TI products are designated by TI as compliant with ISO/TS 16949 requirements. Buyers acknowledge and agree that, if they use any non-designated products in automotive applications, TI will not be responsible for any failure to meet such requirements.

Following are URLs where you can obtain information on other Texas Instruments products and application solutions:

### Products

Audio	<a href="http://www.ti.com/audio">www.ti.com/audio</a>
Amplifiers	<a href="http://amplifier.ti.com">amplifier.ti.com</a>
Data Converters	<a href="http://dataconverter.ti.com">dataconverter.ti.com</a>
DLP® Products	<a href="http://www.dlp.com">www.dlp.com</a>
DSP	<a href="http://dsp.ti.com">dsp.ti.com</a>
Clocks and Timers	<a href="http://www.ti.com/clocks">www.ti.com/clocks</a>
Interface	<a href="http://interface.ti.com">interface.ti.com</a>
Logic	<a href="http://logic.ti.com">logic.ti.com</a>
Power Mgmt	<a href="http://power.ti.com">power.ti.com</a>
Microcontrollers	<a href="http://microcontroller.ti.com">microcontroller.ti.com</a>
RFID	<a href="http://www.ti-rfid.com">www.ti-rfid.com</a>
OMAP Mobile Processors	<a href="http://www.ti.com/omap">www.ti.com/omap</a>
Wireless Connectivity	<a href="http://www.ti.com/wirelessconnectivity">www.ti.com/wirelessconnectivity</a>

### Applications

Communications and Telecom	<a href="http://www.ti.com/communications">www.ti.com/communications</a>
Computers and Peripherals	<a href="http://www.ti.com/computers">www.ti.com/computers</a>
Consumer Electronics	<a href="http://www.ti.com/consumer-apps">www.ti.com/consumer-apps</a>
Energy and Lighting	<a href="http://www.ti.com/energy">www.ti.com/energy</a>
Industrial	<a href="http://www.ti.com/industrial">www.ti.com/industrial</a>
Medical	<a href="http://www.ti.com/medical">www.ti.com/medical</a>
Security	<a href="http://www.ti.com/security">www.ti.com/security</a>
Space, Avionics and Defense	<a href="http://www.ti.com/space-avionics-defense">www.ti.com/space-avionics-defense</a>
Transportation and Automotive	<a href="http://www.ti.com/automotive">www.ti.com/automotive</a>
Video and Imaging	<a href="http://www.ti.com/video">www.ti.com/video</a>

TI E2E Community Home Page

[e2e.ti.com](http://e2e.ti.com)

Mailing Address: Texas Instruments, Post Office Box 655303, Dallas, Texas 75265  
Copyright © 2011, Texas Instruments Incorporated