



# Programmable, Off-Line, PWM Controller

## FEATURES

- All Control, Driving, Monitoring, and Protection Functions Included
- Low-current, Off-line Start Circuit
- Voltage Feed Forward or Current Mode Control
- Guaranteed Duty Cycle Clamp
- PWM Latch for Single Pulse per Period
- Pulse-by-Pulse Current Limiting Plus Shutdown for Over-Current Fault
- No Start-up or Shutdown Transients
- Slow Turn-on Both Initially and After Fault Shutdown
- Shutdown Upon Over- or Under-Voltage Sensing
- Latch Off or Continuous Retry After Fault
- PWM Output Switch Usable to 1A Peak Current
- 1% Reference Accuracy
- 500kHz Operation
- 18 Pin DIL Package

## DESCRIPTION

The UC1841 family of PWM controllers has been designed to increase the level of versatility while retaining all of the performance features of the earlier UC1840 devices. While still optimized for highly-efficient bootstrapped primary-side operation in forward or flyback power converters, the UC1841 is equally adept in implementing both low and high voltage input DC to DC converters. Important performance features include a low-current starting circuit, linear feed-forward for constant volt-second operation, and compatibility with either voltage or current mode topologies.

In addition to start-up and normal regulating PWM functions, these devices include built in protection from over-voltage, under-voltage, and over-current fault conditions with the option for either latch-off or automatic restart.

While pin compatible with the UC1840 in all respects except that the polarity of the External Stop has been reversed, the UC1841 offers the following improvements:

1. Fault latch reset is accomplished with slow start discharge rather than recycling the input voltage to the chip.
2. The External Stop input can be used for a fault delay to resist shutdown from short duration transients.
3. The duty-cycle clamping function has been characterized and specified.

The UC1841 is characterized for -55°C to +125°C operation while the UC2841 and UC3841 are designed for -25°C to +85°C and 0° to +70°C, respectively.

## BLOCK DIAGRAM

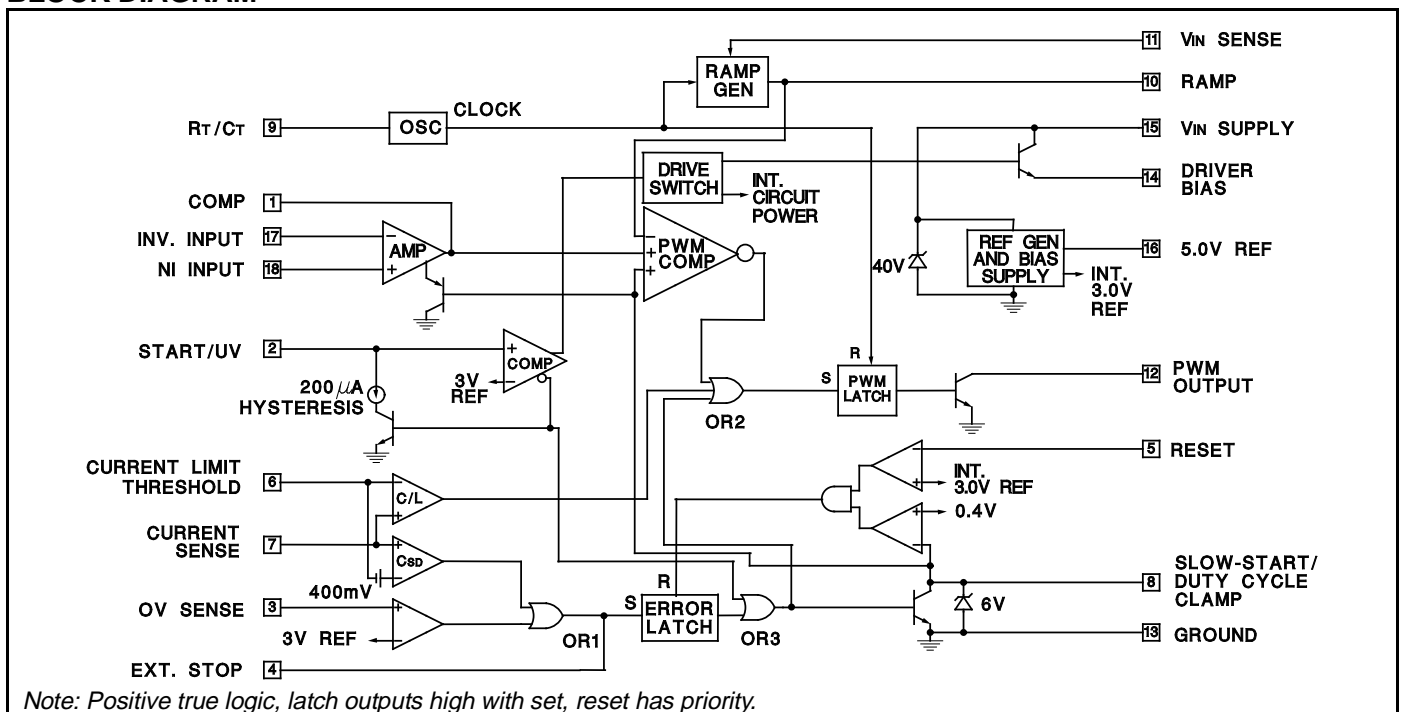

**ABSOLUTE MAXIMUM RATINGS**

Supply Voltage, +V<sub>IN</sub> (Pin 15) (Note 2)  
 Voltage Driven . . . . . +32V  
 Current Driven, 100mA maximum. . . . . Self-limiting  
 PWM Output Voltage (Pin 12) . . . . . 40V  
 PWM Output Current, Steady-State (Pin 12) . . . . . 400mA  
 PWM Output Peak Energy Discharge . . . . . 20μJoules  
 Driver Bias Current (Pin 14) . . . . . -200mA  
 Reference Output Current (Pin 16) . . . . . -50mA  
 Slow-Start Sink Current (Pin 8) . . . . . 20mA  
 V<sub>IN</sub> Sense Current (Pin 11) . . . . . 10mA  
 Current Limit Inputs (Pins 6 & 7) . . . . . -0.5 to +5.5V  
 Stop Input (Pin 4) . . . . . -0.3 to +5.5V  
 Comparator Inputs  
 (Pins 1, 7, 9-11, 16) . . . . . Internally clamped at 12V  
 Power Dissipation at T<sub>A</sub> = 25°C (Note 3) . . . . . 1000mW  
 Power Dissipation at T<sub>C</sub> = 25°C (Note 3) . . . . . 2000mW

Operating Junction Temperature . . . . . -55°C to +150°C  
 Storage Temperature Range. . . . . -65°C to +150°C  
 Lead Temperature (Soldering, 10 sec) . . . . . +300°C

Note 1: All voltages are with respect to ground, Pin 13.  
 Currents are positive-into, negative-out of the specified terminal.

Note 2: All pin numbers are referenced to DIL-18 package.

Note 3: Consult Packaging Section of Databook for thermal limitations and considerations of package.

**CONNECTION DIAGRAMS**

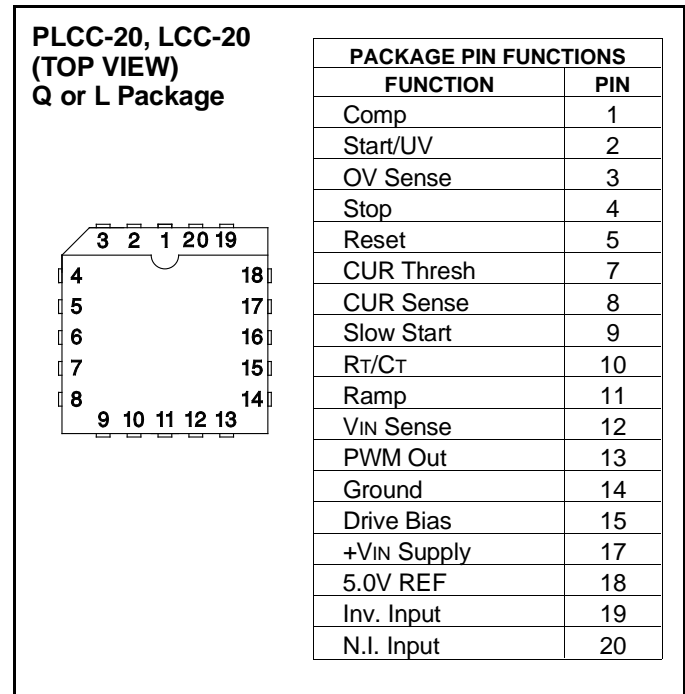
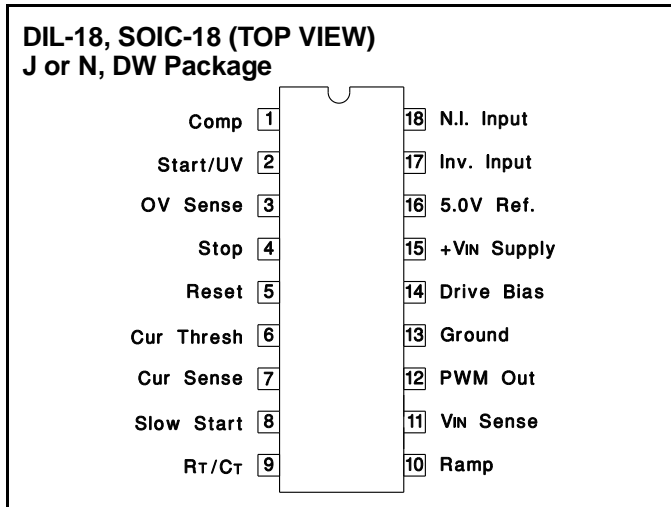

**ELECTRICAL CHARACTERISTICS:** Unless otherwise stated, these specifications apply for T<sub>A</sub> = -55°C to +125°C for the UC1841, -25°C to +85°C for the UC2841, and 0°C to +70°C for the UC3841; V<sub>IN</sub> = 20V, R<sub>T</sub> = 20kΩ, C<sub>T</sub> = .001mfd, R<sub>R</sub> = 10kΩ, C<sub>R</sub> = .001mfd, Current Limit Threshold = 200mV, T<sub>A</sub> = T<sub>J</sub>.

PARAMETER	TEST CONDITIONS	UC1841 / UC2841			UC3841			UNITS
		MIN	TYP	MAX	MIN	TYP	MAX	
<b>Power Inputs</b>								
Start-Up Current	V <sub>IN</sub> = 30V, Pin 2 = 2.5V		4.5	6		4.5	6	mA
Operating Current	V <sub>IN</sub> = 30V, Pin 2 = 3.5V		10	14		10	14	mA
Supply OV Clamp	I <sub>IN</sub> = 20mA	33	40	45	33	40	45	V
<b>Reference Section</b>								
Reference Voltage	T <sub>J</sub> = 25°C	4.95	5.0	5.05	4.9	5.0	5.1	V
Line Regulation	V <sub>IN</sub> = 8 to 30V		10	15		10	20	mV
Load Regulation	I <sub>L</sub> = 0 to 10mA		10	20		10	30	mV
Temperature Stability	Over Operating Temperature Range	4.9		5.1	4.85		5.15	V
Short Circuit Current	V <sub>REF</sub> = 0, T <sub>J</sub> = 25°C		-80	-100		-80	-100	mA
<b>Oscillator</b>								
Nominal Frequency	T <sub>J</sub> = 25°C	47	50	53	45	50	55	kHz
Voltage Stability	V <sub>IN</sub> = 8 to 30V		0.5	1		0.5	1	%
Temperature Stability	Over Operating Temperature Range	45		55	43		57	kHz
Maximum Frequency	R <sub>T</sub> = 2kΩ, C <sub>T</sub> = 330pF	500			500			kHz

**ELECTRICAL CHARACTERISTICS:** Unless otherwise stated, these specifications apply for  $T_A = -55^\circ\text{C}$  to  $+125^\circ\text{C}$  for the UC1841,  $-25^\circ\text{C}$  to  $+85^\circ\text{C}$  for the UC2841, and  $0^\circ\text{C}$  to  $+70^\circ\text{C}$  for the UC3841;  $V_{IN} = 20\text{V}$ ,  $R_T = 20\text{k}\Omega$ ,  $C_T = .001\text{mfd}$ ,  $R_R = 10\text{k}\Omega$ ,  $C_R = .001\text{mfd}$ , Current Limit Threshold =  $200\text{mV}$ ,  $T_A = T_J$ .

PARAMETER	TEST CONDITIONS	UC1841 / UC2841			UC3841			UNITS
		MIN	TYP	MAX	MIN	TYP	MAX	
<b>Ramp Generator</b>								
Ramp Current, Minimum	$I_{SENSE} = -10\mu\text{A}$		-11	-14		-11	-14	$\mu\text{A}$
Ramp Current, Maximum	$I_{SENSE} = 1.0\text{mA}$	-0.9	-95		-0.9	-95		$\text{mA}$
Ramp Valley		0.3	0.4	0.6	0.3	0.4	0.6	$\text{V}$
Ramp Peak	Clamping Level	3.9	4.2	4.5	3.9	4.2	4.5	$\text{V}$
<b>Error Amplifier</b>								
Input Offset Voltage	$V_{CM} = 5.0\text{V}$		0.5	5		2	10	$\text{mV}$
Input Bias Current			0.5	2		1	5	$\mu\text{A}$
Input Offset Current				0.5			0.5	$\mu\text{A}$
Open Loop Gain	$\Delta V_O = 1$ to $3\text{V}$	60	66		60	66		$\text{dB}$
Output Swing (Max. Output $\leq$ Ramp Peak - $100\text{mV}$ )	Minimum Total Range	0.3		3.5	0.3		3.5	$\text{V}$
CMRR	$V_{CM} = 1.5$ to $5.5\text{V}$	70	80		70	80		$\text{dB}$
PSRR	$V_{IN} = 8$ to $30\text{V}$	70	80		70	80		$\text{dB}$
Short Circuit Current	$V_{COMP} = 0\text{V}$		-4	-10		-4	-10	$\text{mA}$
Gain Bandwidth*	$T_J = 25^\circ\text{C}$ , $A_{VOL} = 0\text{dB}$	1	2		1	2		$\text{MHz}$
Slew Rate*	$T_J = 25^\circ\text{C}$ , $A_{VCL} = 0\text{dB}$		0.8			0.8		$\text{V}/\mu\text{s}$
<b>PWM Section</b>								
Continuous Duty Cycle Range* (other than zero)	Minimum Total Continuous Range, Ramp Peak $< 4.2\text{V}$	4		95	4		95	%
50% Duty Cycle Clamp	$R_{SENSE}$ to $V_{REF} = 10\text{k}$	42	47	52	42	47	52	%
Output Saturation	$I_{OUT} = 20\text{mA}$		0.2	0.4		0.2	0.4	$\text{V}$
	$I_{OUT} = 200\text{mA}$		1.7	2.2		1.7	2.2	$\text{V}$
Output Leakage	$V_{OUT} = 40\text{V}$		0.1	10		0.1	10	$\mu\text{A}$
Comparator Delay*	Pin 8 to Pin 12, $T_J = 25^\circ\text{C}$ , $R_L = 1\text{k}\Omega$		300	500		300	500	$\text{ns}$
<b>Sequencing Functions</b>								
Comparator Thresholds	Pins 2, 3, 5	2.8	3.0	3.2	2.8	3.0	3.2	$\text{V}$
Input Bias Current	Pins 3, 5 = $0\text{V}$		-1.0	-4.0		-1.0	-4.0	$\mu\text{A}$
Input Leakage	Pins 3, 5 = $10\text{V}$		0.1	2.0		0.1	2.0	$\mu\text{A}$
Start/UV Hysteresis Current	Pin 2 = $2.5\text{V}$	170	200	220	170	200	230	$\mu\text{A}$
Ext. Stop Threshold	Pin 4	0.8	1.6	2.4	0.8	1.6	2.4	$\text{V}$
Error Latch Activate Current	Pin 4 = $0\text{V}$ , Pin 3 $> 3\text{V}$		-120	-200		-120	-200	$\mu\text{A}$
Driver Bias Saturation Voltage, $V_{IN} - V_{OH}$	$I_B = -50\text{mA}$		2	3		2	3	$\text{V}$
Driver Bias Leakage	$V_B = 0\text{V}$		-0.1	-10		-0.1	-10	$\mu\text{A}$
Slow-Start Saturation	$I_S = 10\text{mA}$		0.2	0.5		0.2	0.5	$\text{V}$
Slow-Start Leakage	$V_S = 4.5\text{V}$		0.1	2.0		0.1	2.0	$\mu\text{A}$
<b>Current Control</b>								
Current Limit Offset			0	5		0	10	$\text{mV}$
Current Shutdown Offset		370	400	430	360	400	440	$\text{mV}$
Input Bias Current	Pin 7 = $0\text{V}$		-2	-5		-2	-5	$\mu\text{A}$
Common Mode Range*		-0.4		3.0	-0.4		3.0	$\text{V}$
Current Limit Delay*	$T_J = 25^\circ\text{C}$ , Pin 7 to 12, $R_L = 1\text{k}$		200	400		200	400	$\text{ns}$

\* These parameters are guaranteed by design but not 100% tested in production.

## FUNCTIONAL DESCRIPTION

<b>PWM CONTROL</b>	
1. Oscillator	Generates a fixed-frequency internal clock from an external $R_T$ and $C_T$ . Frequency = $\frac{K_C}{R_T C_T}$ where $K_C$ is a first order correction factor $\approx 0.3 \log(C_T \times 10^{12})$ .
2. Ramp Generator	Develops a linear ramp with a slope defined externally by $\frac{dv}{dt} = \frac{\text{sense voltage}}{R_R C_R}$ $C_R$ is normally selected $\leq C_T$ and its value will have some effect upon valley voltage. Limiting the minimum value for $I_{SENSE}$ will establish a maximum duty cycle clamp. $C_R$ terminal can be used as an input port for current mode control.
3. Error Amplifier	Conventional operational amplifier for closed-loop gain and phase compensation. Low output impedance; unity-gain stable. The output is held low by the slow start voltage at turn on in order to minimize overshoot.
4. Reference Generator	Precision 5.0V for internal and external usage to 50mA. Tracking 3.0V reference for internal usage only with nominal accuracy of $\pm 2\%$ . 40V clamp zener for chip OV protection, 100mA maximum current.
5. PWM Comparator	Generates output pulse which starts at termination of clock pulse and ends when the ramp input crosses the lowest of two positive inputs.
6. PWM Latch	Terminates the PWM output pulse when set by inputs from either the PWM comparator, the pulse-by-pulse current limit comparator, or the error latch. Resets with each internal clock pulse.
7. PWM Output Switch	Transistor capable of sinking current to ground which is off during the PWM on-time and turns on to terminate the power pulse. Current capacity is 400mA saturated with peak capacitance discharge in excess of one amp.
<b>SEQUENCING FUNCTIONS</b>	
1. Start/UV Sense	With an increasing voltage, it generates a turn-on signal and releases the slow-start clamp at a start threshold. With a decreasing voltage, it generates a turn-off command at a lower level separated by a 200 $\mu$ A hysteresis current.
2. Drive Switch	Disables most of the chip to hold internal current consumption low, and Driver Bias OFF, until input voltage reaches start threshold.
3. Driver Bias	Supplies drive current to external power switch to provide turn-on bias.
4. Slow Start	Clamps low to hold PWM OFF. Upon release, rises with rate controlled by $R_S C_S$ for slow increase of output pulse width. Can also be used as an alternate maximum duty cycle clamp with an external voltage divider.
<b>PROTECTION FUNCTIONS</b>	
1. Error Latch	When set by momentary input, this latch insures immediate PWM shutdown and hold off until reset. Inputs to Error Latch are: a. OV > 3.2V (typically 3V) b. Stop > 2.4V (typically 1.6V) c. Current Sense 400mV over threshold (typical). Error Latch resets when slow start voltage falls to 0.4V if Reset Pin 5 < 2.8V. With Pin 5 > 3.2V, Error Latch will remain set.
2. Current Limiting	Differential input comparator terminates individual output pulses each time sense voltage rises above threshold. When sense voltage rises to 400mV (typical) above threshold, a shutdown signal is sent to Error Latch.
3. External Stop	A voltage over 1.2V will set the Error Latch and hold the output off. A voltage less than 0.8V will defeat the error latch and prevent shutdown. A capacitor here will slow the action of the error latch for transient protection by providing a typical delay of 13ms/ $\mu$ F.

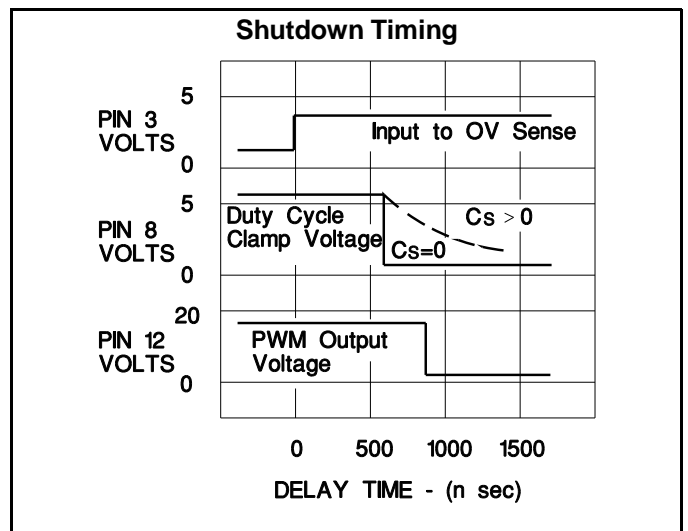
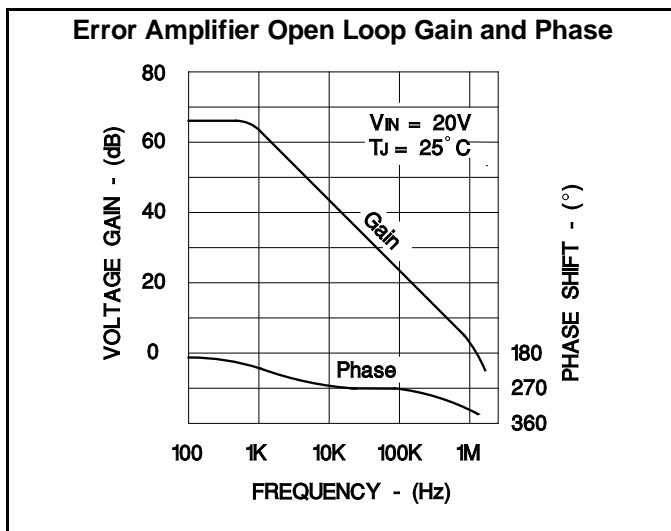
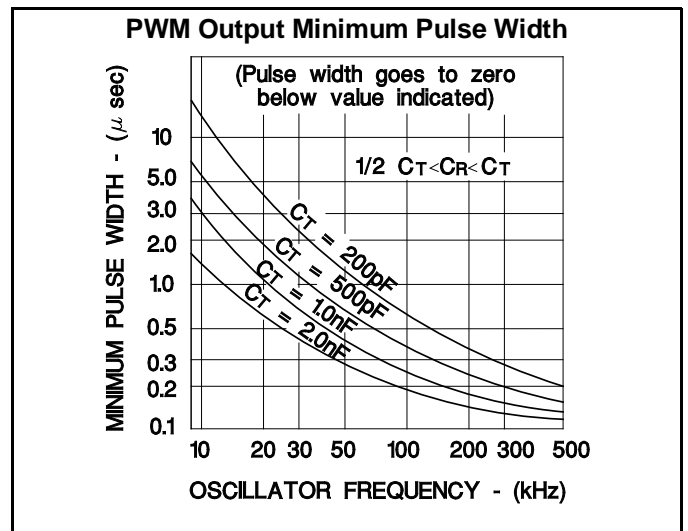
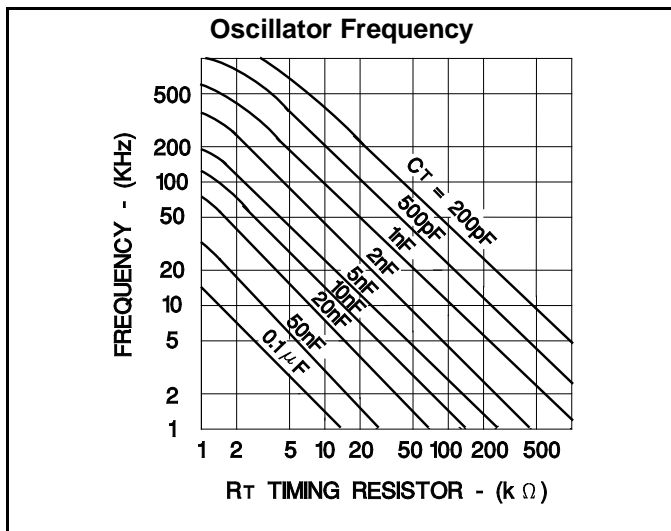
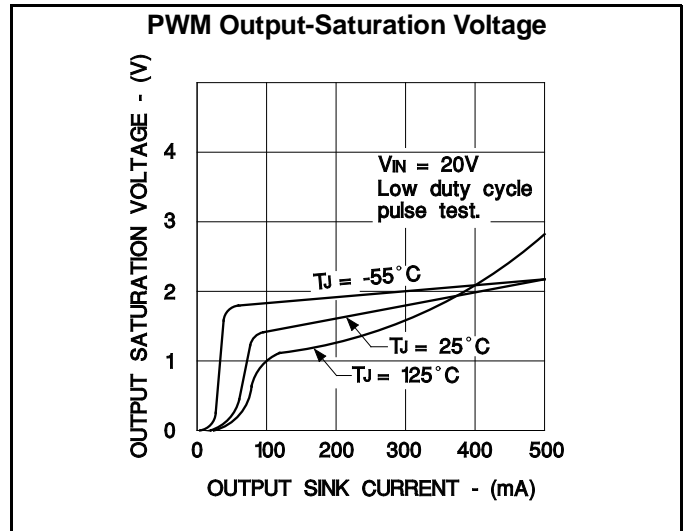
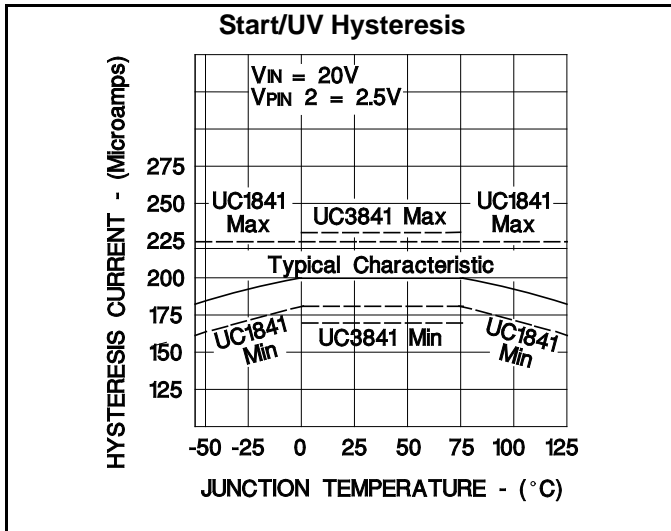

**OPEN-LOOP TEST CIRCUIT**

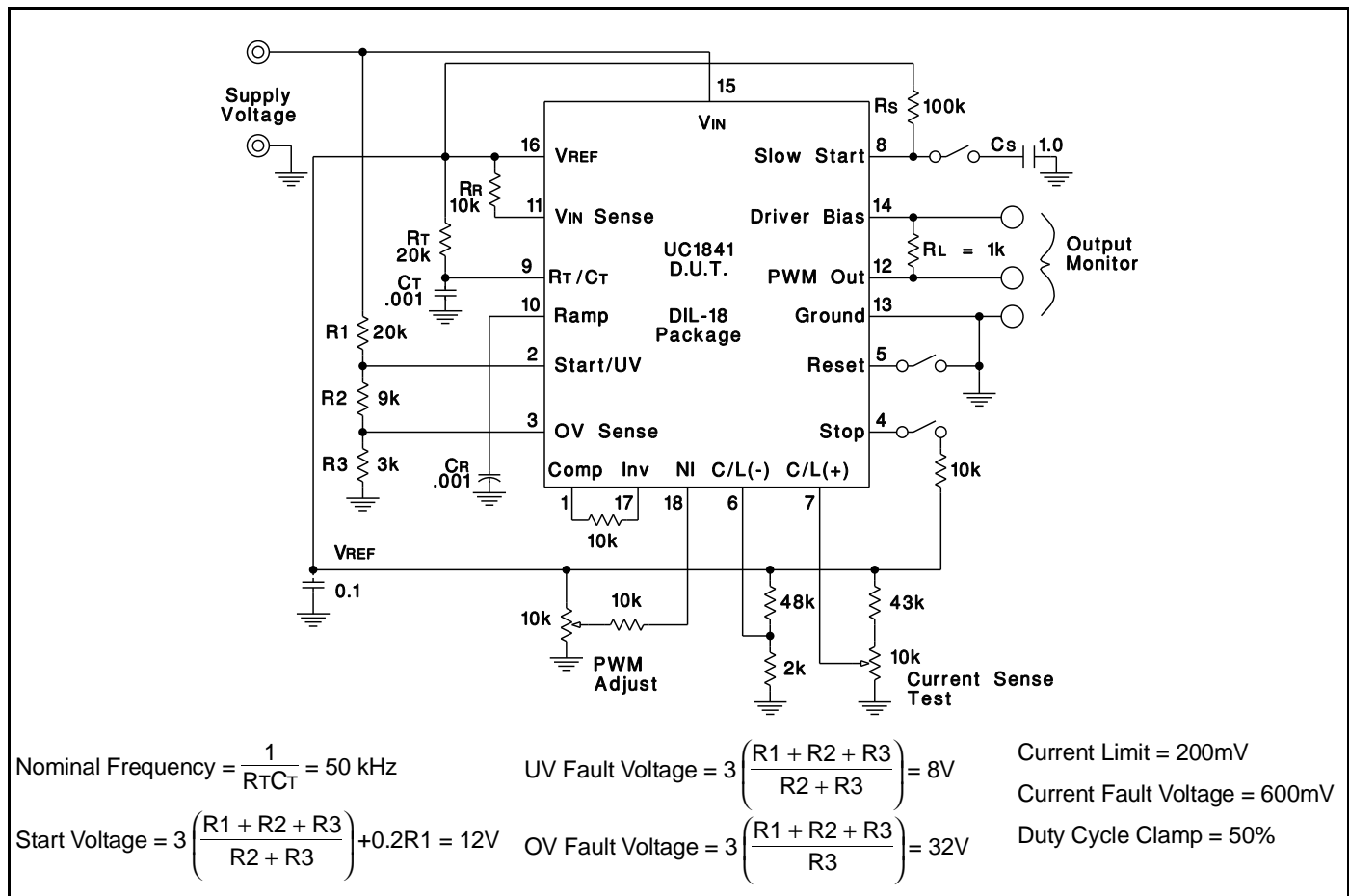

**FLYBACK APPLICATION (A)**

In this application (see Figure A, next page), complete control is maintained on the primary side. Control power is provided by  $R_{IN}$  and  $C_{IN}$  during start-up, and by a primary-referenced low voltage winding, N2, for efficient operation after start. The error amplifier loop is closed to regulate the DC voltage from N2 with other outputs following through their magnetic coupling – a task made even easier with the UC1841's feed-forward line regulation.

An extension to this application for more precise regulation would be the use of the UC1901 Isolated Feedback Generator for direct closed-loop control to an output.

Not shown, are protective snubbers or additional interface circuitry which may be required by the choice of the high-voltage switch,  $Q_s$ , or the application; however, one example of power transistor interfacing is provided on the following page.

**REGULATOR APPLICATION (B)**

With the addition of a level shifting transistor, Q1, the UC1841 is an ideal control circuit for DC to DC converters such as the buck regulator shown in Figure B opposite. In addition to providing constant current drive pulses to the PIC661 power switch, this circuit has full fault protection and high speed dynamic line regulation due to its feed-forward capability. An additional feature is the ability to

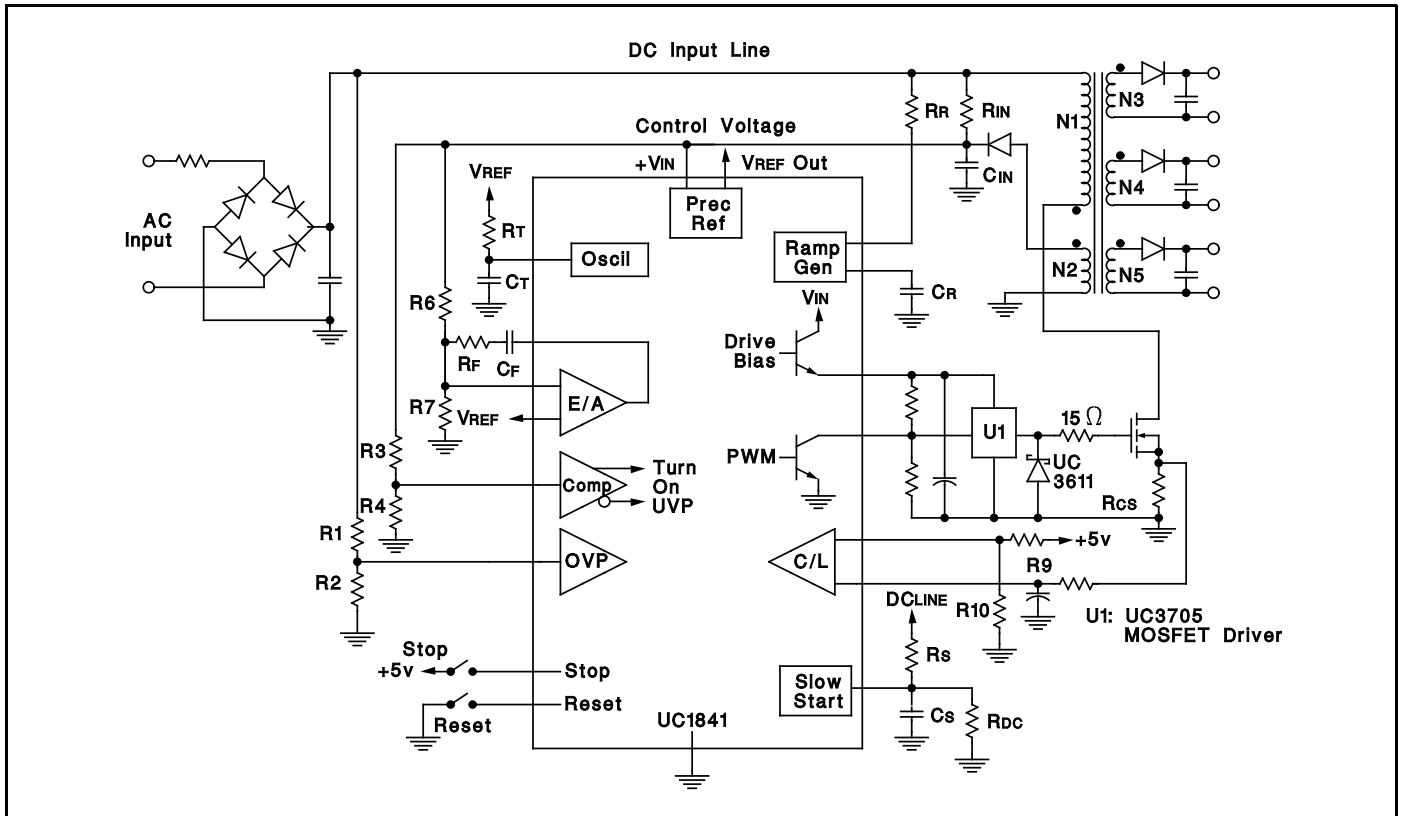

Figure A. UC1841 Programmable PWM Controller In A Simplified Flyback Regulator

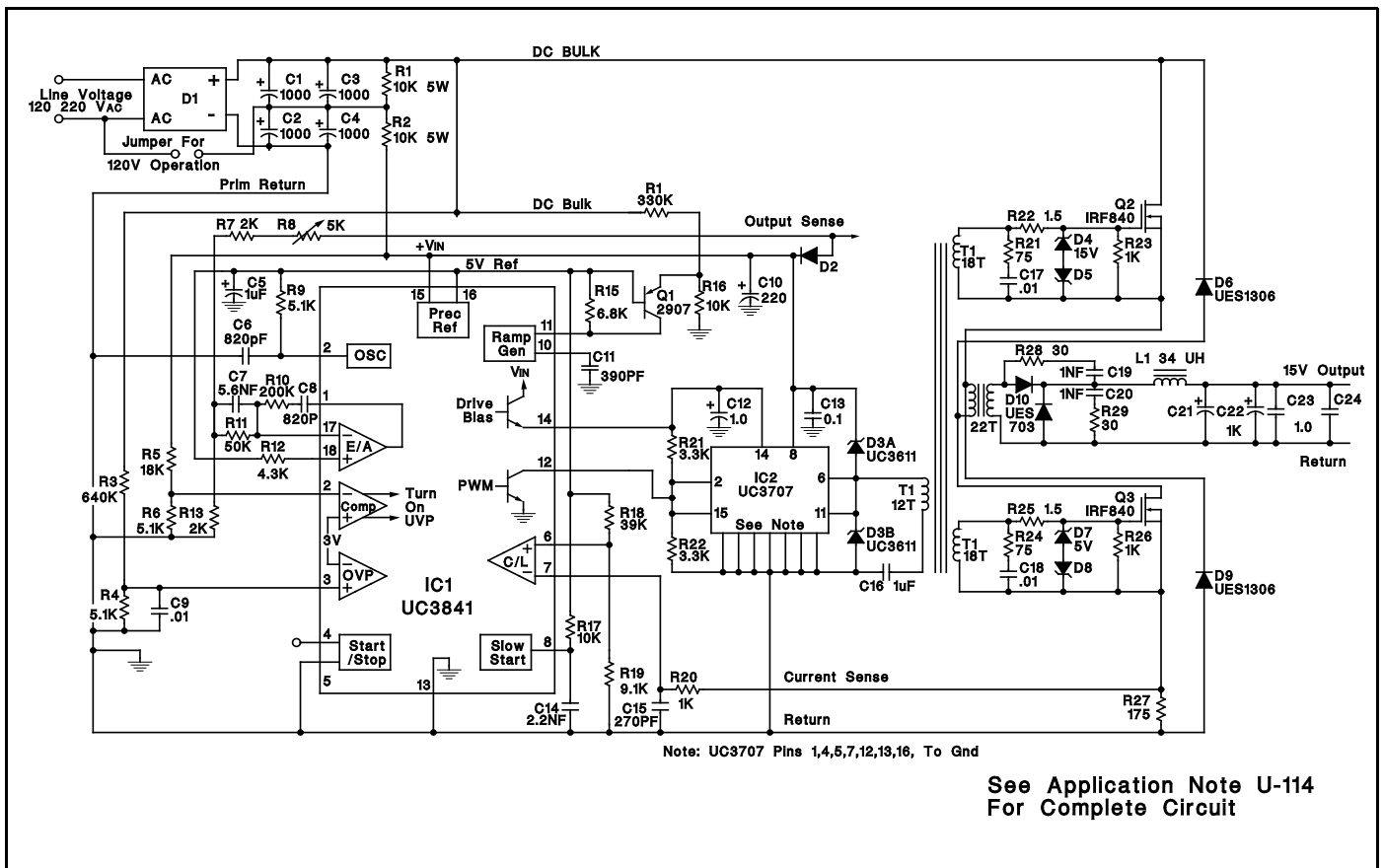
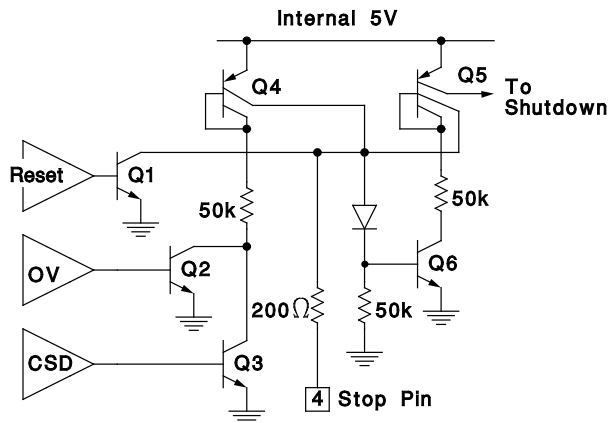

Figure B. Overall Schematic For A 300 Watt, Off-line Power Converter Using The UC3841 For Control

### ERROR LATCH INTERNAL CIRCUITRY



The Error Latch consists of Q5 and Q6 which, when both on, turns off the PWM Output and pulls the Slow-Start pin low. This latch is set by either the Over-Voltage or Current Shutdown comparators, or by a high signal on Pin 4. Reset is accomplished by either the Reset comparator or a low signal on Pin 4. An activation time delay can be provided with an external capacitor on Pin 4 in conjunction with the  $\approx 100\mu\text{A}$  collector current from Q4.

### PROGRAMMABLE SOFT START AND RESTART DELAY CIRCUIT

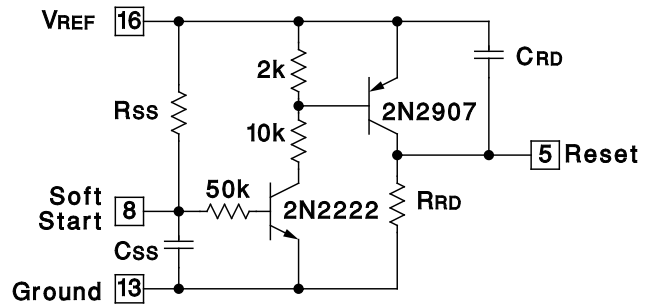

$$\text{Restart Delay} = (.51)(RRD)(CRD)$$

### CURRENT MODE CONTROL

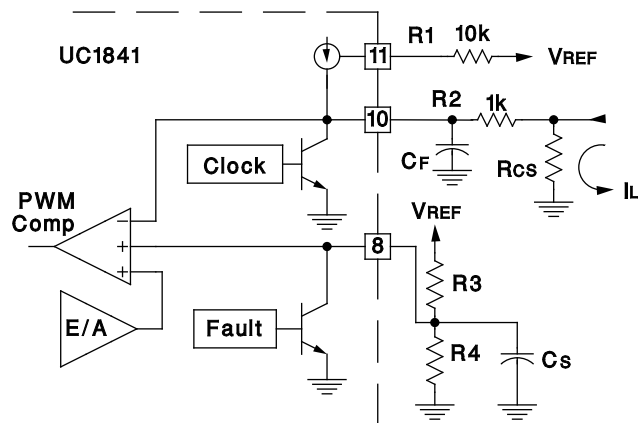

Since Pin 10 is a direct input to the PWM comparator, this point can also serve as a current sense port for current mode control. In this application, current sensing is ground referenced through  $R_{cs}$ . Resistor  $R_1$  sets a 400mV offset across  $R_2$  (assuming  $R_2 > R_{cs}$ ) so that both the Error Amplifier and Fault Shutdown can force the current completely to zero.  $R_2$  is also used along with  $C_f$  as a small filter to attenuate leading-edge spikes on the load current waveform. In this mode, current limiting can be accomplished by divider  $R_3/R_4$  which forms a clamp overriding the output of the Error Amplifier.

### VOLTAGE FEED-FORWARD COMBINED WITH MAXIMUM DUTY-CYCLE CLAMP

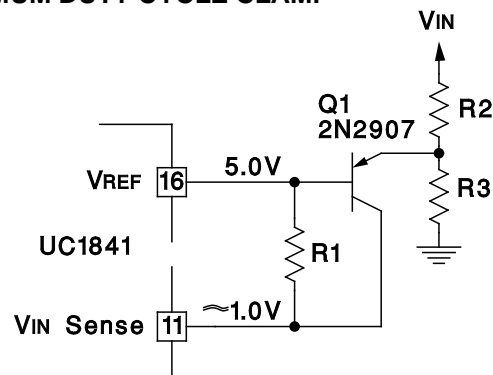

In this circuit,  $R_1$  is used in conjunction with  $C_R$  (not shown) to establish a minimum ramp charging current such that the ramp voltage reaches 4.2V at the required maximum output pulse width.

The purpose of  $Q_1$  is to provide an increasing ramp current above a threshold established by  $R_2$  and  $R_3$  such that the duty cycle is further reduced with increasing  $V_{IN}$ .

The minimum ramp current is:

$$I_R(\text{MIN}) = \frac{V_{REF} - V_{IN \text{ SENSE}}}{R_1} \approx \frac{4V}{R_1}$$

The threshold where  $V_{IN}$  begins to add extra ramp current is:

$$V_{IN} \approx 5.6V \left( \frac{R_2 + R_3}{R_3} \right)$$

Above the threshold, the ramp current will be:

$$I_R(\text{VARIABLE}) \approx \frac{4}{R_1} + \frac{V_{IN} - 5.6}{R_2} - \frac{5.6}{R_3}$$

to Customer on an annual basis.

**PACKAGING INFORMATION**

Orderable Device	Status <sup>(1)</sup>	Package Type	Package Drawing	Pins	Package Qty	Eco Plan <sup>(2)</sup>	Lead/Ball Finish	MSL Peak Temp <sup>(3)</sup>
5962-8992002VA	OBSOLETE	CDIP	J	18		TBD	Call TI	Call TI
UC1841J	OBSOLETE	CDIP	J	18		TBD	Call TI	Call TI
UC1841J883B	OBSOLETE	CDIP	J	18		TBD	Call TI	Call TI
UC1841L	OBSOLETE	LCCC	FK	20		TBD	Call TI	Call TI
UC1841L883B	OBSOLETE	LCCC	FK	20		TBD	Call TI	Call TI
UC2841DW	ACTIVE	SOIC	DW	18	40	Green (RoHS & no Sb/Br)	CU NIPDAU	Level-2-260C-1 YEAR
UC2841DWG4	ACTIVE	SOIC	DW	18	40	Green (RoHS & no Sb/Br)	CU NIPDAU	Level-2-260C-1 YEAR
UC2841DWTR	ACTIVE	SOIC	DW	18	2000	Green (RoHS & no Sb/Br)	CU NIPDAU	Level-2-260C-1 YEAR
UC2841DWTRG4	ACTIVE	SOIC	DW	18	2000	Green (RoHS & no Sb/Br)	CU NIPDAU	Level-2-260C-1 YEAR
UC2841J	OBSOLETE	CDIP	J	18		TBD	Call TI	Call TI
UC2841N	ACTIVE	PDIP	N	18	20	Green (RoHS & no Sb/Br)	CU NIPDAU	N / A for Pkg Type
UC2841NG4	ACTIVE	PDIP	N	18	20	Green (RoHS & no Sb/Br)	CU NIPDAU	N / A for Pkg Type
UC3841DW	ACTIVE	SOIC	DW	18	40	Green (RoHS & no Sb/Br)	CU NIPDAU	Level-2-260C-1 YEAR
UC3841DWG4	ACTIVE	SOIC	DW	18	40	Green (RoHS & no Sb/Br)	CU NIPDAU	Level-2-260C-1 YEAR
UC3841DWTR	ACTIVE	SOIC	DW	18	2000	Green (RoHS & no Sb/Br)	CU NIPDAU	Level-2-260C-1 YEAR
UC3841DWTRG4	ACTIVE	SOIC	DW	18	2000	Green (RoHS & no Sb/Br)	CU NIPDAU	Level-2-260C-1 YEAR
UC3841J	OBSOLETE	CDIP	J	18		TBD	Call TI	Call TI
UC3841N	ACTIVE	PDIP	N	18	20	Green (RoHS & no Sb/Br)	CU NIPDAU	N / A for Pkg Type
UC3841NG4	ACTIVE	PDIP	N	18	20	Green (RoHS & no Sb/Br)	CU NIPDAU	N / A for Pkg Type

<sup>(1)</sup> The marketing status values are defined as follows:

**ACTIVE:** Product device recommended for new designs.

**LIFEBUY:** TI has announced that the device will be discontinued, and a lifetime-buy period is in effect.

**NRND:** Not recommended for new designs. Device is in production to support existing customers, but TI does not recommend using this part in a new design.

**PREVIEW:** Device has been announced but is not in production. Samples may or may not be available.

**OBSOLETE:** TI has discontinued the production of the device.

<sup>(2)</sup> Eco Plan - The planned eco-friendly classification: Pb-Free (RoHS), Pb-Free (RoHS Exempt), or Green (RoHS & no Sb/Br) - please check <http://www.ti.com/productcontent> for the latest availability information and additional product content details.

**TBD:** The Pb-Free/Green conversion plan has not been defined.

**Pb-Free (RoHS):** TI's terms "Lead-Free" or "Pb-Free" mean semiconductor products that are compatible with the current RoHS requirements for all 6 substances, including the requirement that lead not exceed 0.1% by weight in homogeneous materials. Where designed to be soldered at high temperatures, TI Pb-Free products are suitable for use in specified lead-free processes.

**Pb-Free (RoHS Exempt):** This component has a RoHS exemption for either 1) lead-based flip-chip solder bumps used between the die and package, or 2) lead-based die adhesive used between the die and leadframe. The component is otherwise considered Pb-Free (RoHS compatible) as defined above.

**Green (RoHS & no Sb/Br):** TI defines "Green" to mean Pb-Free (RoHS compatible), and free of Bromine (Br) and Antimony (Sb) based flame retardants (Br or Sb do not exceed 0.1% by weight in homogeneous material)

<sup>(3)</sup> MSL, Peak Temp. -- The Moisture Sensitivity Level rating according to the JEDEC industry standard classifications, and peak solder temperature.

**Important Information and Disclaimer:**The information provided on this page represents TI's knowledge and belief as of the date that it is provided. TI bases its knowledge and belief on information provided by third parties, and makes no representation or warranty as to the accuracy of such information. Efforts are underway to better integrate information from third parties. TI has taken and continues to take reasonable steps to provide representative and accurate information but may not have conducted destructive testing or chemical analysis on incoming materials and chemicals. TI and TI suppliers consider certain information to be proprietary, and thus CAS numbers and other limited information may not be available for release.

In no event shall TI's liability arising out of such information exceed the total purchase price of the TI part(s) at issue in this document sold by TI to Customer on an annual basis.

## IMPORTANT NOTICE

Texas Instruments Incorporated and its subsidiaries (TI) reserve the right to make corrections, modifications, enhancements, improvements, and other changes to its products and services at any time and to discontinue any product or service without notice. Customers should obtain the latest relevant information before placing orders and should verify that such information is current and complete. All products are sold subject to TI's terms and conditions of sale supplied at the time of order acknowledgment.

TI warrants performance of its hardware products to the specifications applicable at the time of sale in accordance with TI's standard warranty. Testing and other quality control techniques are used to the extent TI deems necessary to support this warranty. Except where mandated by government requirements, testing of all parameters of each product is not necessarily performed.

TI assumes no liability for applications assistance or customer product design. Customers are responsible for their products and applications using TI components. To minimize the risks associated with customer products and applications, customers should provide adequate design and operating safeguards.

TI does not warrant or represent that any license, either express or implied, is granted under any TI patent right, copyright, mask work right, or other TI intellectual property right relating to any combination, machine, or process in which TI products or services are used. Information published by TI regarding third-party products or services does not constitute a license from TI to use such products or services or a warranty or endorsement thereof. Use of such information may require a license from a third party under the patents or other intellectual property of the third party, or a license from TI under the patents or other intellectual property of TI.

Reproduction of information in TI data books or data sheets is permissible only if reproduction is without alteration and is accompanied by all associated warranties, conditions, limitations, and notices. Reproduction of this information with alteration is an unfair and deceptive business practice. TI is not responsible or liable for such altered documentation.

Resale of TI products or services with statements different from or beyond the parameters stated by TI for that product or service voids all express and any implied warranties for the associated TI product or service and is an unfair and deceptive business practice. TI is not responsible or liable for any such statements.

Following are URLs where you can obtain information on other Texas Instruments products and application solutions:

### Products

Amplifiers	<a href="http://amplifier.ti.com">amplifier.ti.com</a>
Data Converters	<a href="http://dataconverter.ti.com">dataconverter.ti.com</a>
DSP	<a href="http://dsp.ti.com">dsp.ti.com</a>
Interface	<a href="http://interface.ti.com">interface.ti.com</a>
Logic	<a href="http://logic.ti.com">logic.ti.com</a>
Power Mgmt	<a href="http://power.ti.com">power.ti.com</a>
Microcontrollers	<a href="http://microcontroller.ti.com">microcontroller.ti.com</a>
Low Power Wireless	<a href="http://www.ti.com/lpw">www.ti.com/lpw</a>

### Applications

Audio	<a href="http://www.ti.com/audio">www.ti.com/audio</a>
Automotive	<a href="http://www.ti.com/automotive">www.ti.com/automotive</a>
Broadband	<a href="http://www.ti.com/broadband">www.ti.com/broadband</a>
Digital Control	<a href="http://www.ti.com/digitalcontrol">www.ti.com/digitalcontrol</a>
Military	<a href="http://www.ti.com/military">www.ti.com/military</a>
Optical Networking	<a href="http://www.ti.com/opticalnetwork">www.ti.com/opticalnetwork</a>
Security	<a href="http://www.ti.com/security">www.ti.com/security</a>
Telephony	<a href="http://www.ti.com/telephony">www.ti.com/telephony</a>
Video & Imaging	<a href="http://www.ti.com/video">www.ti.com/video</a>
Wireless	<a href="http://www.ti.com/wireless">www.ti.com/wireless</a>

Mailing Address: Texas Instruments  
Post Office Box 655303 Dallas, Texas 75265