

HIGH SPEED POWER DRIVER

 Check for Samples: [UC1705](#), [UC2705](#), [UC3705](#)

FEATURES

- 1.5 A Source/Sink Drive
- 100 nsec Delay
- 40 nsec Rise Fall into 1000 pF
- Inverting and Non-Inverting Inputs
- Low Cross-Conduction Current Spike
- Low Quiescent Current
- 5 V to 40 V Operation
- Thermal Shutdown Protection
- Minidip and Power Packages

DESCRIPTION

The UC1705 family of power drivers is made with a high speed Schottky process to interface between low-level control functions and high-power switching devices - particularly power MOSFETs. These devices are also an optimum choice for capacitive line drivers where up to 1.5 A may be switched in either direction. With both inverting and non-inverting inputs available, logic signals of either polarity may be accepted, or one input can be used to gate or strobe the other.

Supply voltages for both V_S and V_C can independently range from 5 V to 40 V. For additional application details, see the UC1707/3707 data sheet ([SLUS177](#)).

The UC1705 is packaged in an 8-pin hermetically sealed Cerdip for -55°C to 125°C operation. The UC3705 is specified for a temperature range of 0°C to 70°C and is available in either a plastic minidip or a 5-pin, power TO-220 package.

TRUTH TABLE⁽¹⁾⁽²⁾

INV	N.I	OUT
H	H	L
L	H	H
H	L	L
L	L	L

 (1) $\overline{OUT} = \overline{INV}$ and N.I.

 (2) $\overline{OUT} = INV$ and N.i.

BLOCK DIAGRAM

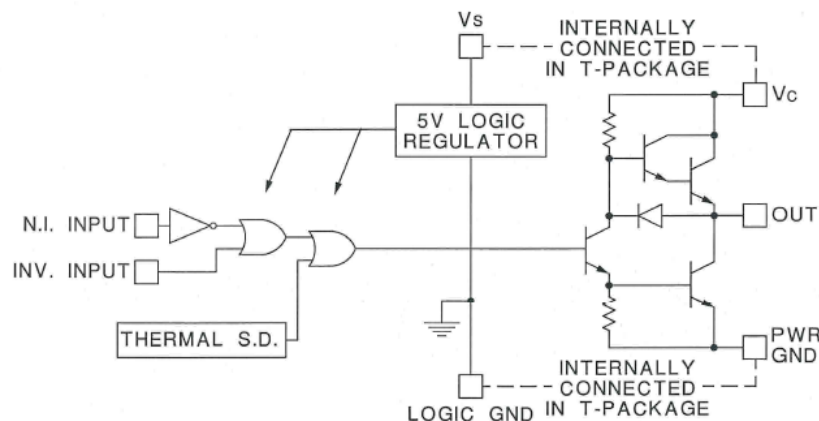

Please be aware that an important notice concerning availability, standard warranty, and use in critical applications of Texas Instruments semiconductor products and disclaimers thereto appears at the end of this data sheet.



These devices have limited built-in ESD protection. The leads should be shorted together or the device placed in conductive foam during storage or handling to prevent electrostatic damage to the MOS gates.

CONNECTION DIAGRAMS

**DIL-8 MINIDIP, SOIC-8
(TOP VIEW)
N, JG OR D PACKAGE**

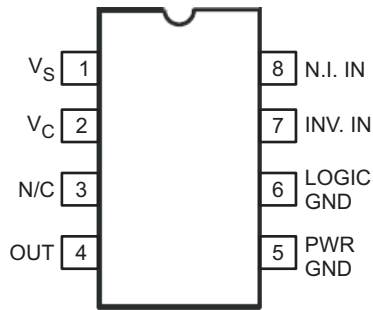

**5-PIN TO-220
(TOP VIEW)
T PACKAGE**

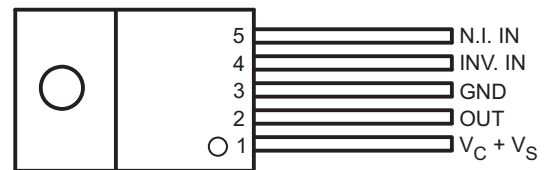

**LCCC-20
(TOP VIEW)
FK PACKAGE**

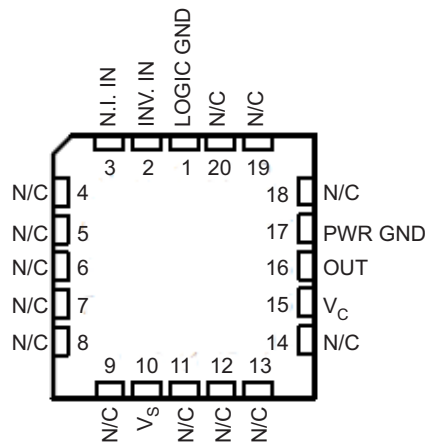

ABSOLUTE MAXIMUM RATINGS⁽¹⁾

	VALUE			UNIT
	N-Pkg	JG-Pkg	T-Pkg	
Supply Voltage (V_{IN})	40	40	40	V
Collector Supply Voltage, V_C	40	40	40	
Output current (source or sink)				
Steady-State	±500	±500	±1	A
Peak Transient	±1.5	±1	±2	A
Capacitive Discharge Energy	20	15	50	μJ
Digital Inputs ⁽²⁾	5.5	5.5	5.5	V
Power Dissipation at $T_A = 25^\circ\text{C}$ ⁽¹⁾	1	1	3	W
Power Dissipation at T_A (Lead/Case) = 25°C ⁽¹⁾	3	2	25	W
Operating Temperature Range	0 to 70	-55 to 125	0 to 70	°C
Storage temperature	-65 to 150	-65 to 150	-65 to 150	°C

(1) All currents are positive into, negative out of the specified terminal.

(2) Digital Drive can exceed 5.5 V if the input current is limited to 10 mA

ELECTRICAL CHARACTERISTICS

Unless otherwise stated, these specifications apply for $T_A = -55^\circ\text{C}$ to $+125^\circ\text{C}$ for the UC1705, -25°C to $+85^\circ\text{C}$ for the UC2707, and 0°C to $+70^\circ\text{C}$ for the UC3705; $V_{IN} = V_C = 20\text{ V}$. $T_A = T_J$.

PARAMETER		TEST CONDITIONS	MIN	TYP	MAX	UNIT
V_S	Supply current	$V_S = 40\text{ V}$, outputs high, T package		6	8	mA
		$V_C = 40\text{ V}$, outputs low, T package		6	12	mA
V_C	Supply current (N, JG Only)	$V_C = 40\text{ V}$, outputs low		2	4	mA
V_C	Leakage current (N, JG Only)	$V_S = 0$, $V_C = 30\text{ V}$		0.05	0.1	mA
	Digital input low level				0.8	V
	Digital input high level		2.2			V
	Input current	$V_I = 0$		-0.6	-1	mA
	Input leakage	$V_I = 5\text{ V}$		0.05	0.1	mA
$V_C - V_O$	Output high saturation	$I_O = -50\text{ mA}$			2	V
		$I_O = -500\text{ mA}$			2.5	V
V_O	Output low saturation	$I_O = -50\text{ mA}$			0.4	V
		$I_O = -500\text{ mA}$			2.5	V
	Thermal shutdown			155		°C

TYPICAL SWITCHING CHARACTERISTICS

$V_{IN} = V_C = 20\text{ V}$, $T_A = 25^\circ\text{C}$. Delays measured to 10% output change.

PARAMETER	TEST CONDITIONS	OUTPUT CL =			UNIT
From Inv. Input to Output		open	1	2.2	nF
Rise time delay		60	60	60	ns
10% to 90% rise		20	40	60	ns
Fall time delay		60	60	60	ns
90% to 10% fall		25	40	50	ns
From N.I. Input to Output					
Rise time delay		90	90	90	ns
10% to 90% rise		20	40	60	ns
Fall time delay		60	60	60	ns
90% to 10% fall		25	40	50	ns
V_C cross-conduction current spike duration	Output rise	25			ns
	Output fall	0			ns

APPLICATION INFORMATION

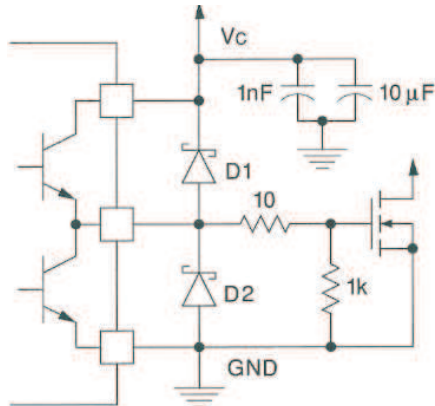

D1, D2: UC3611 Schottky Diodes

Figure 1. Power MOSFET Drive Circuit

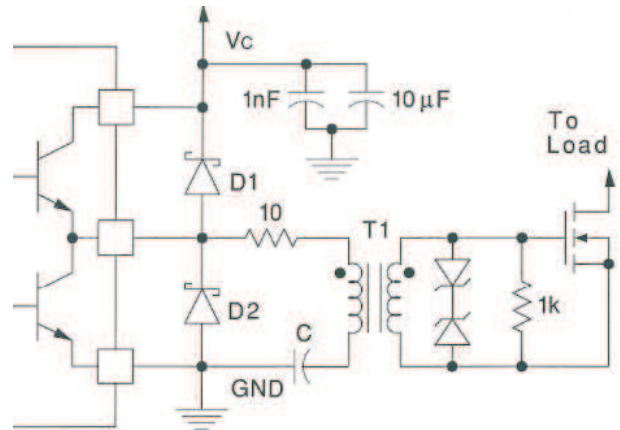

D1, D2: UC3611 Schottky Diodes

Figure 3. Transformer Coupled MOSFET DRIVE Circuit

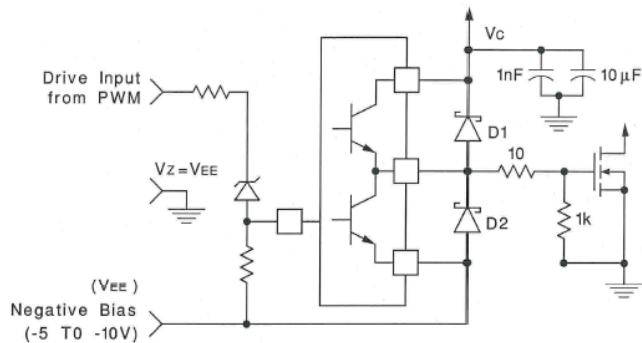

D1, D2: UC3611 Schottky Diodes

Figure 2. Power MOSFET Drive Circuit Using Negative Bias Voltage and Level Shifting to Ground Referenced PWMs

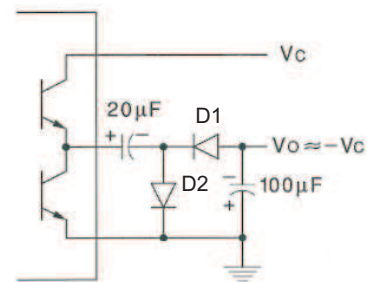
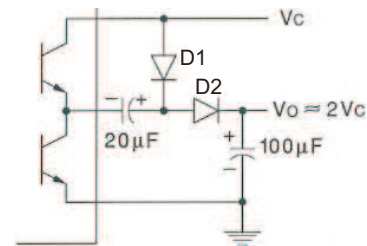

Figure 4. Charge Pump Circuit

REVISION HISTORY

Changes from Revision C (December, 2011) to Revision D	Page
• Deleted SN54BCT373 from title for FK package image	2

PACKAGING INFORMATION

Orderable Device	Status ⁽¹⁾	Package Type	Package Drawing	Pins	Package Qty	Eco Plan ⁽²⁾	Lead/ Ball Finish	MSL Peak Temp ⁽³⁾	Samples (Requires Login)
5962-9579801M2A	ACTIVE	LCCC	FK	20	1	TBD	Call TI	Call TI	
5962-9579801MPA	ACTIVE	CDIP	JG	8	1	TBD	Call TI	Call TI	
5962-9579801VPA	ACTIVE	CDIP	JG	8	1	TBD	A42	N / A for Pkg Type	
UC1705J	ACTIVE	CDIP	JG	8	1	TBD	A42	N / A for Pkg Type	
UC1705J883B	ACTIVE	CDIP	JG	8	1	TBD	A42	N / A for Pkg Type	
UC1705L883B	ACTIVE	LCCC	FK	20	1	TBD	POST-PLATE	N / A for Pkg Type	
UC2705D	ACTIVE	SOIC	D	8	75	Green (RoHS & no Sb/Br)	CU NIPDAU	Level-2-260C-1 YEAR	
UC2705DG4	ACTIVE	SOIC	D	8	75	Green (RoHS & no Sb/Br)	CU NIPDAU	Level-2-260C-1 YEAR	
UC2705N	ACTIVE	PDIP	P	8	50	Green (RoHS & no Sb/Br)	CU NIPDAU	N / A for Pkg Type	
UC2705NG4	ACTIVE	PDIP	P	8	50	Green (RoHS & no Sb/Br)	CU NIPDAU	N / A for Pkg Type	
UC3705D	ACTIVE	SOIC	D	8	75	Green (RoHS & no Sb/Br)	CU NIPDAU	Level-2-260C-1 YEAR	
UC3705DG4	ACTIVE	SOIC	D	8	75	Green (RoHS & no Sb/Br)	CU NIPDAU	Level-2-260C-1 YEAR	
UC3705DTR	ACTIVE	SOIC	D	8	2500	Green (RoHS & no Sb/Br)	CU NIPDAU	Level-2-260C-1 YEAR	
UC3705DTRG4	ACTIVE	SOIC	D	8	2500	Green (RoHS & no Sb/Br)	CU NIPDAU	Level-2-260C-1 YEAR	
UC3705J	ACTIVE	CDIP	JG	8	1	TBD	A42	N / A for Pkg Type	
UC3705N	ACTIVE	PDIP	P	8	50	Green (RoHS & no Sb/Br)	CU NIPDAU	N / A for Pkg Type	
UC3705NG4	ACTIVE	PDIP	P	8	50	Green (RoHS & no Sb/Br)	CU NIPDAU	N / A for Pkg Type	
UC3705T	ACTIVE	TO-220	KC	5	50	Green (RoHS & no Sb/Br)	CU SN	N / A for Pkg Type	
UC3705TG3	ACTIVE	TO-220	KC	5	50	Green (RoHS & no Sb/Br)	CU SN	N / A for Pkg Type	

⁽¹⁾ The marketing status values are defined as follows:

ACTIVE: Product device recommended for new designs.

LIFEBUY: TI has announced that the device will be discontinued, and a lifetime-buy period is in effect.

NRND: Not recommended for new designs. Device is in production to support existing customers, but TI does not recommend using this part in a new design.

PREVIEW: Device has been announced but is not in production. Samples may or may not be available.

OBSOLETE: TI has discontinued the production of the device.

⁽²⁾ Eco Plan - The planned eco-friendly classification: Pb-Free (RoHS), Pb-Free (RoHS Exempt), or Green (RoHS & no Sb/Br) - please check <http://www.ti.com/productcontent> for the latest availability information and additional product content details.

TBD: The Pb-Free/Green conversion plan has not been defined.

Pb-Free (RoHS): TI's terms "Lead-Free" or "Pb-Free" mean semiconductor products that are compatible with the current RoHS requirements for all 6 substances, including the requirement that lead not exceed 0.1% by weight in homogeneous materials. Where designed to be soldered at high temperatures, TI Pb-Free products are suitable for use in specified lead-free processes.

Pb-Free (RoHS Exempt): This component has a RoHS exemption for either 1) lead-based flip-chip solder bumps used between the die and package, or 2) lead-based die adhesive used between the die and leadframe. The component is otherwise considered Pb-Free (RoHS compatible) as defined above.

Green (RoHS & no Sb/Br): TI defines "Green" to mean Pb-Free (RoHS compatible), and free of Bromine (Br) and Antimony (Sb) based flame retardants (Br or Sb do not exceed 0.1% by weight in homogeneous material)

⁽³⁾ MSL, Peak Temp. -- The Moisture Sensitivity Level rating according to the JEDEC industry standard classifications, and peak solder temperature.

Important Information and Disclaimer: The information provided on this page represents TI's knowledge and belief as of the date that it is provided. TI bases its knowledge and belief on information provided by third parties, and makes no representation or warranty as to the accuracy of such information. Efforts are underway to better integrate information from third parties. TI has taken and continues to take reasonable steps to provide representative and accurate information but may not have conducted destructive testing or chemical analysis on incoming materials and chemicals. TI and TI suppliers consider certain information to be proprietary, and thus CAS numbers and other limited information may not be available for release.

In no event shall TI's liability arising out of such information exceed the total purchase price of the TI part(s) at issue in this document sold by TI to Customer on an annual basis.

OTHER QUALIFIED VERSIONS OF UC1705, UC1705-SP, UC3705, UC3705M :

● Catalog: [UC3705](#), [UC1705](#), [UC3705M](#), [UC3705](#)

● Military: [UC1705](#)

● Space: [UC1705-SP](#)

NOTE: Qualified Version Definitions:

● Catalog - TI's standard catalog product

● Military - QML certified for Military and Defense Applications

● Space - Radiation tolerant, ceramic packaging and qualified for use in Space-based application

TAPE AND REEL INFORMATION
REEL DIMENSIONS

TAPE DIMENSIONS

A0	Dimension designed to accommodate the component width
B0	Dimension designed to accommodate the component length
K0	Dimension designed to accommodate the component thickness
W	Overall width of the carrier tape
P1	Pitch between successive cavity centers

TAPE AND REEL INFORMATION

*All dimensions are nominal

Device	Package Type	Package Drawing	Pins	SPQ	Reel Diameter (mm)	Reel Width W1 (mm)	A0 (mm)	B0 (mm)	K0 (mm)	P1 (mm)	W (mm)	Pin1 Quadrant
UC3705DTR	SOIC	D	8	2500	330.0	12.4	6.4	5.2	2.1	8.0	12.0	Q1

TAPE AND REEL BOX DIMENSIONS



*All dimensions are nominal

Device	Package Type	Package Drawing	Pins	SPQ	Length (mm)	Width (mm)	Height (mm)
UC3705DTR	SOIC	D	8	2500	367.0	367.0	35.0

JG (R-GDIP-T8)

CERAMIC DUAL-IN-LINE

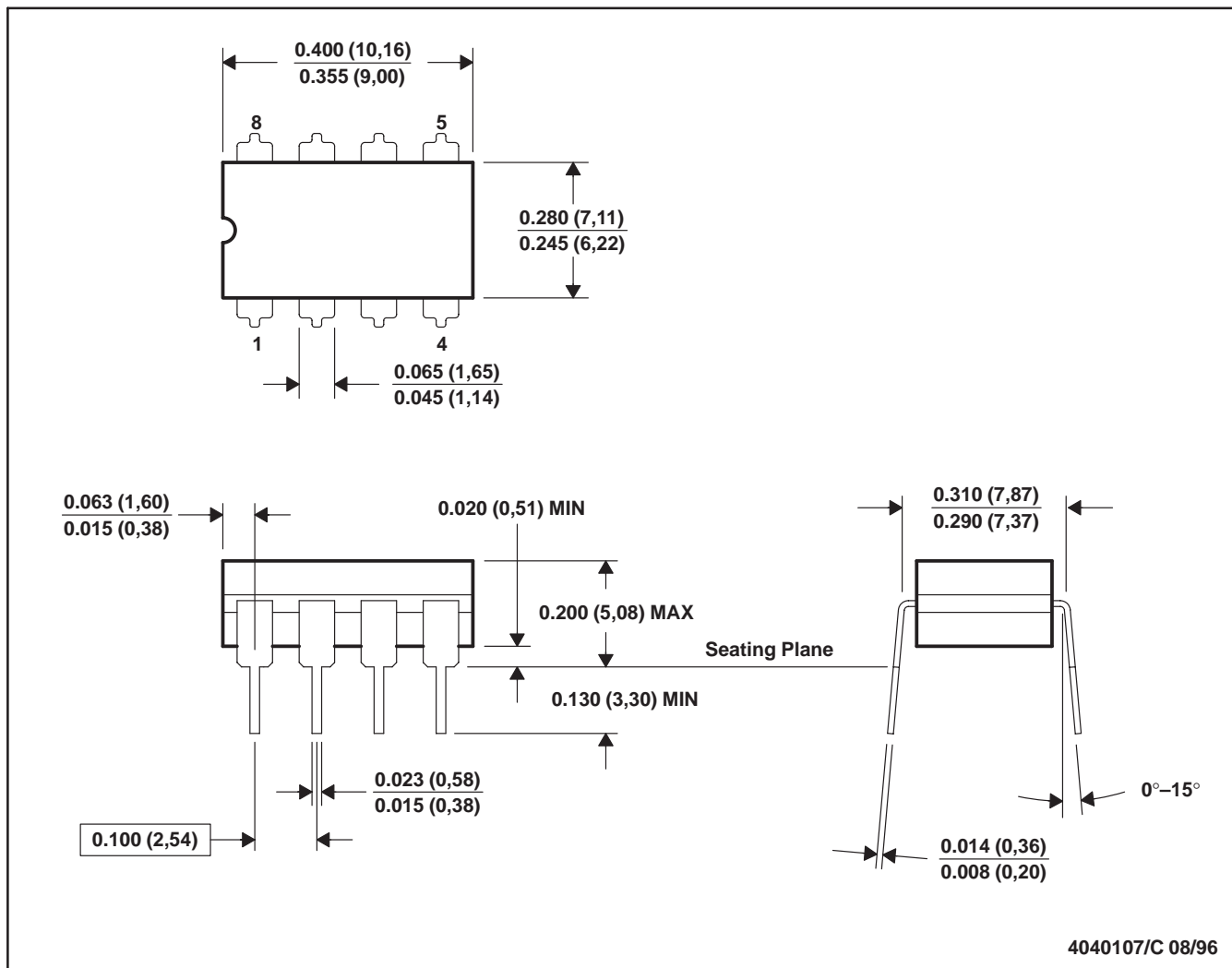

- NOTES: A. All linear dimensions are in inches (millimeters).
 B. This drawing is subject to change without notice.
 C. This package can be hermetically sealed with a ceramic lid using glass frit.
 D. Index point is provided on cap for terminal identification.
 E. Falls within MIL STD 1835 GDIP1-T8

FK (S-CQCC-N**)

LEADLESS CERAMIC CHIP CARRIER

28 TERMINAL SHOWN



NO. OF TERMINALS **	A		B	
	MIN	MAX	MIN	MAX
20	0.342 (8,69)	0.358 (9,09)	0.307 (7,80)	0.358 (9,09)
28	0.442 (11,23)	0.458 (11,63)	0.406 (10,31)	0.458 (11,63)
44	0.640 (16,26)	0.660 (16,76)	0.495 (12,58)	0.560 (14,22)
52	0.740 (18,78)	0.761 (19,32)	0.495 (12,58)	0.560 (14,22)
68	0.938 (23,83)	0.962 (24,43)	0.850 (21,6)	0.858 (21,8)
84	1.141 (28,99)	1.165 (29,59)	1.047 (26,6)	1.063 (27,0)



4040140/D 01/11

- NOTES:
- All linear dimensions are in inches (millimeters).
 - This drawing is subject to change without notice.
 - This package can be hermetically sealed with a metal lid.
 - Falls within JEDEC MS-004

P (R-PDIP-T8)

PLASTIC DUAL-IN-LINE PACKAGE



- NOTES:
- A. All linear dimensions are in inches (millimeters).
 - B. This drawing is subject to change without notice.
 - C. Falls within JEDEC MS-001 variation BA.

D (R-PDSO-G8)

PLASTIC SMALL OUTLINE

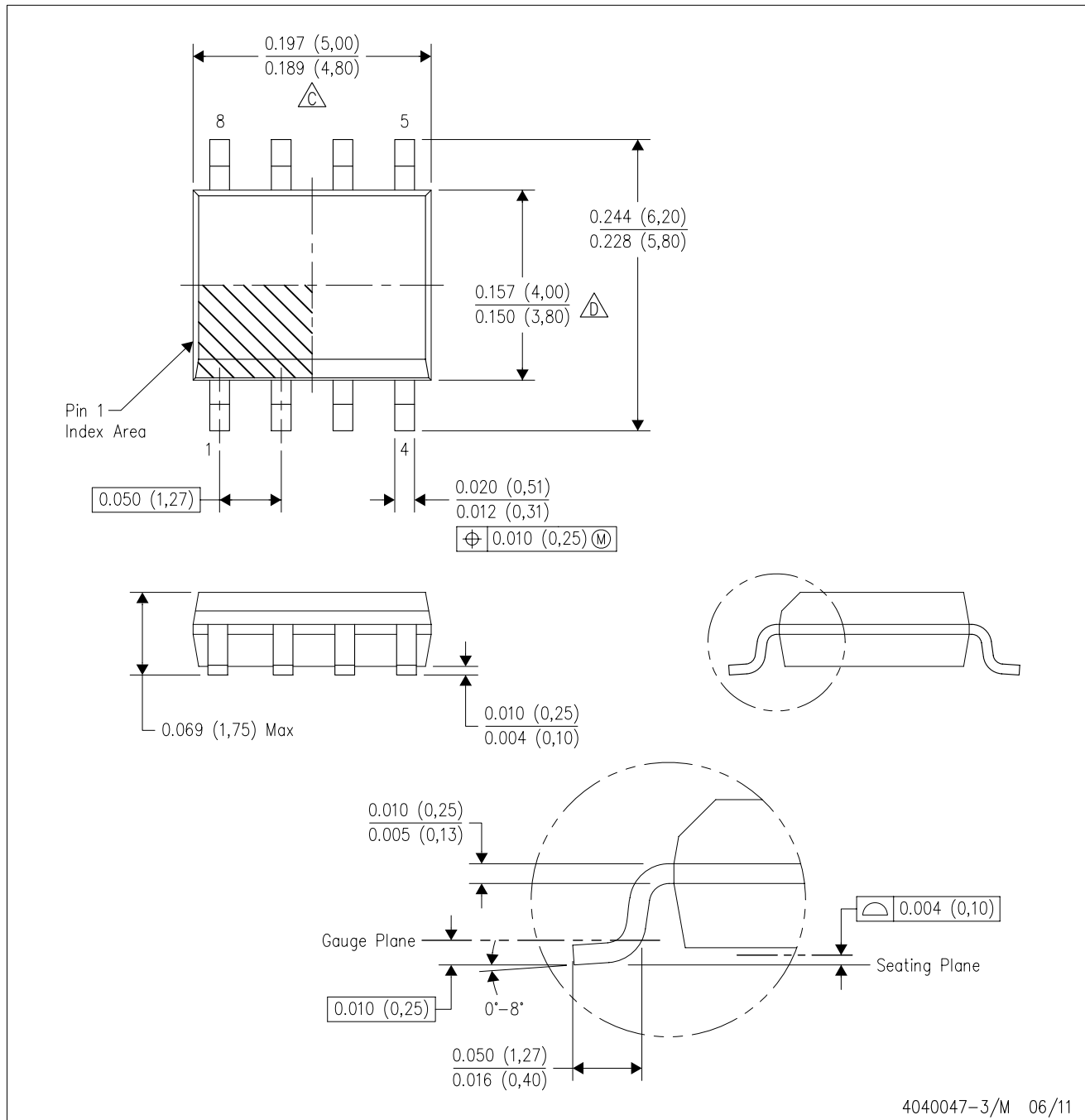

- NOTES:
- A. All linear dimensions are in inches (millimeters).
 - B. This drawing is subject to change without notice.
 - C. Body length does not include mold flash, protrusions, or gate burrs. Mold flash, protrusions, or gate burrs shall not exceed 0.006 (0,15) each side.
 - D. Body width does not include interlead flash. Interlead flash shall not exceed 0.017 (0,43) each side.
 - E. Reference JEDEC MS-012 variation AA.

D (R-PDSO-G8)

PLASTIC SMALL OUTLINE

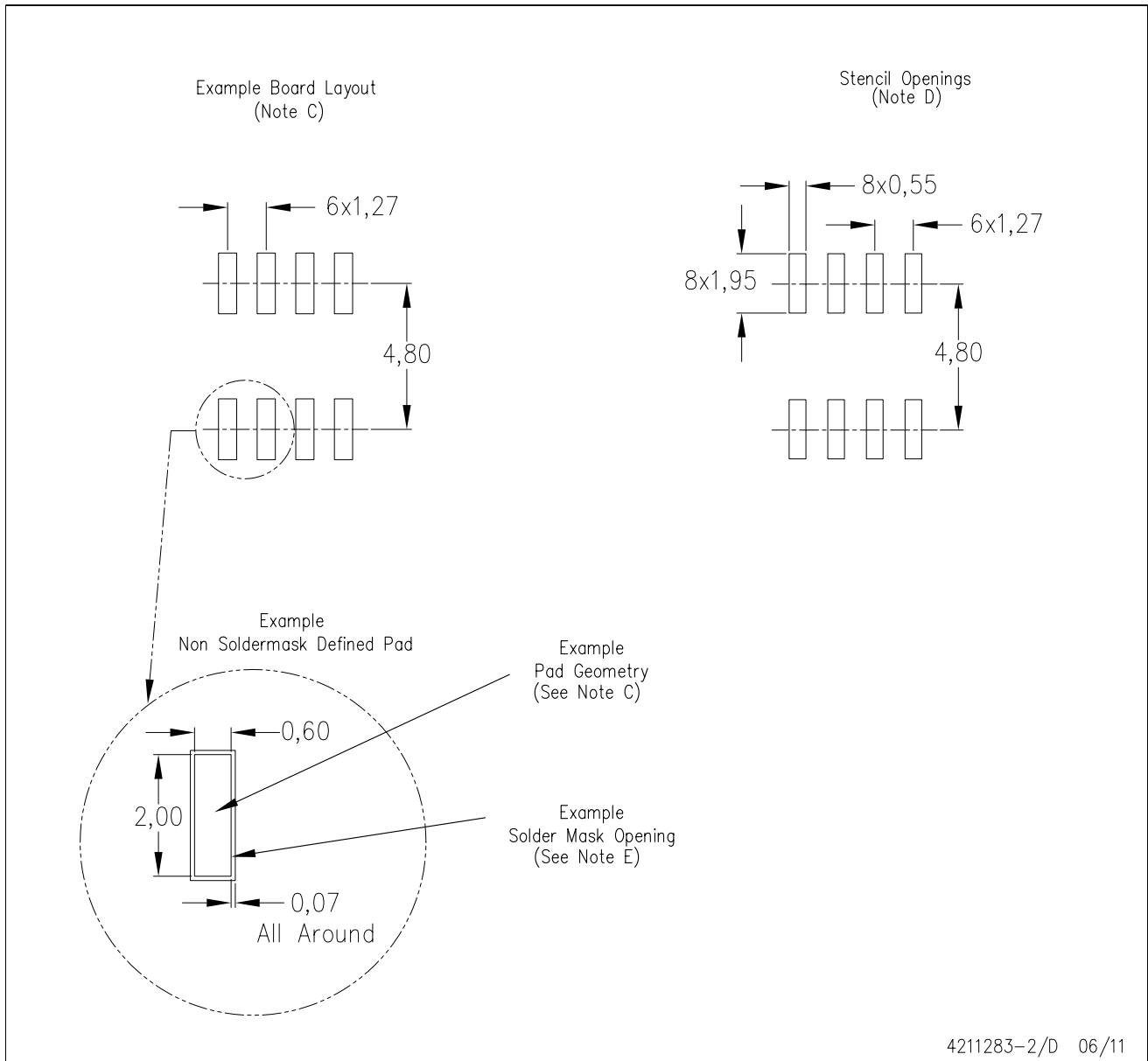

- NOTES:
- All linear dimensions are in millimeters.
 - This drawing is subject to change without notice.
 - Publication IPC-7351 is recommended for alternate designs.
 - Laser cutting apertures with trapezoidal walls and also rounding corners will offer better paste release. Customers should contact their board assembly site for stencil design recommendations. Refer to IPC-7525 for other stencil recommendations.
 - Customers should contact their board fabrication site for solder mask tolerances between and around signal pads.

KC (R-PSFM-T5)

PLASTIC FLANGE-MOUNT PACKAGE

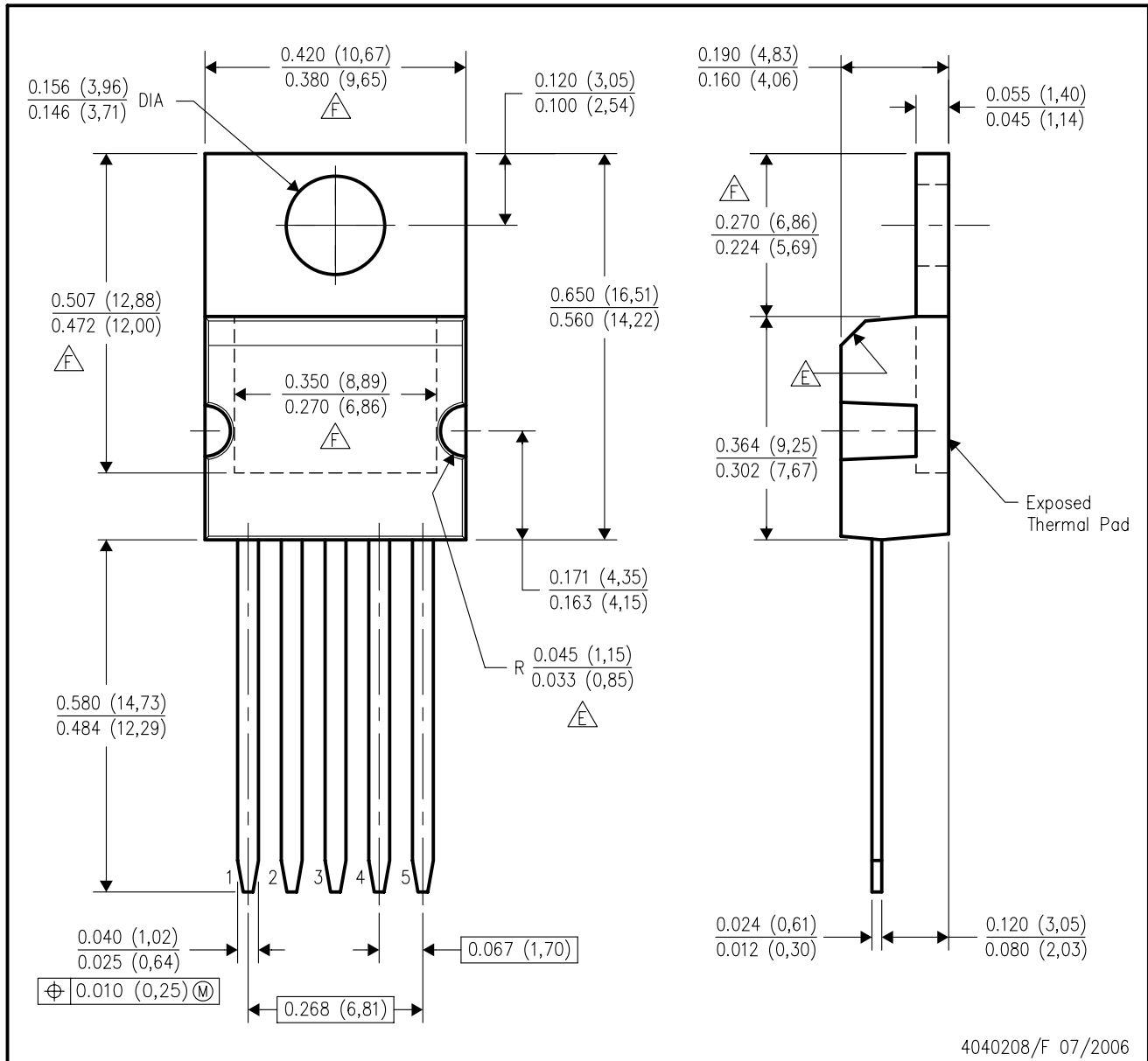

4040208/F 07/2006

- NOTES:
- A. All linear dimensions are in inches (millimeters).
 - B. This drawing is subject to change without notice.
 - C. All lead dimensions apply before solder dip.
 - D. The center lead is in electrical contact with the mounting tab.
 - ⚠ These features are optional.
 - ⚠ Thermal pad contour optional within these dimensions.

IMPORTANT NOTICE

Texas Instruments Incorporated and its subsidiaries (TI) reserve the right to make corrections, enhancements, improvements and other changes to its semiconductor products and services per JESD46C and to discontinue any product or service per JESD48B. Buyers should obtain the latest relevant information before placing orders and should verify that such information is current and complete. All semiconductor products (also referred to herein as "components") are sold subject to TI's terms and conditions of sale supplied at the time of order acknowledgment.

TI warrants performance of its components to the specifications applicable at the time of sale, in accordance with the warranty in TI's terms and conditions of sale of semiconductor products. Testing and other quality control techniques are used to the extent TI deems necessary to support this warranty. Except where mandated by applicable law, testing of all parameters of each component is not necessarily performed.

TI assumes no liability for applications assistance or the design of Buyers' products. Buyers are responsible for their products and applications using TI components. To minimize the risks associated with Buyers' products and applications, Buyers should provide adequate design and operating safeguards.

TI does not warrant or represent that any license, either express or implied, is granted under any patent right, copyright, mask work right, or other intellectual property right relating to any combination, machine, or process in which TI components or services are used. Information published by TI regarding third-party products or services does not constitute a license to use such products or services or a warranty or endorsement thereof. Use of such information may require a license from a third party under the patents or other intellectual property of the third party, or a license from TI under the patents or other intellectual property of TI.

Reproduction of significant portions of TI information in TI data books or data sheets is permissible only if reproduction is without alteration and is accompanied by all associated warranties, conditions, limitations, and notices. TI is not responsible or liable for such altered documentation. Information of third parties may be subject to additional restrictions.

Resale of TI components or services with statements different from or beyond the parameters stated by TI for that component or service voids all express and any implied warranties for the associated TI component or service and is an unfair and deceptive business practice. TI is not responsible or liable for any such statements.

Buyer acknowledges and agrees that it is solely responsible for compliance with all legal, regulatory and safety-related requirements concerning its products, and any use of TI components in its applications, notwithstanding any applications-related information or support that may be provided by TI. Buyer represents and agrees that it has all the necessary expertise to create and implement safeguards which anticipate dangerous consequences of failures, monitor failures and their consequences, lessen the likelihood of failures that might cause harm and take appropriate remedial actions. Buyer will fully indemnify TI and its representatives against any damages arising out of the use of any TI components in safety-critical applications.

In some cases, TI components may be promoted specifically to facilitate safety-related applications. With such components, TI's goal is to help enable customers to design and create their own end-product solutions that meet applicable functional safety standards and requirements. Nonetheless, such components are subject to these terms.

No TI components are authorized for use in FDA Class III (or similar life-critical medical equipment) unless authorized officers of the parties have executed a special agreement specifically governing such use.

Only those TI components which TI has specifically designated as military grade or "enhanced plastic" are designed and intended for use in military/aerospace applications or environments. Buyer acknowledges and agrees that any military or aerospace use of TI components which have **not** been so designated is solely at the Buyer's risk, and that Buyer is solely responsible for compliance with all legal and regulatory requirements in connection with such use.

TI has specifically designated certain components which meet ISO/TS16949 requirements, mainly for automotive use. Components which have not been so designated are neither designed nor intended for automotive use; and TI will not be responsible for any failure of such components to meet such requirements.

Products

Audio	www.ti.com/audio
Amplifiers	amplifier.ti.com
Data Converters	dataconverter.ti.com
DLP® Products	www.dlp.com
DSP	dsp.ti.com
Clocks and Timers	www.ti.com/clocks
Interface	interface.ti.com
Logic	logic.ti.com
Power Mgmt	power.ti.com
Microcontrollers	microcontroller.ti.com
RFID	www.ti-rfid.com
OMAP Mobile Processors	www.ti.com/omap
Wireless Connectivity	www.ti.com/wirelessconnectivity

Applications

Automotive and Transportation	www.ti.com/automotive
Communications and Telecom	www.ti.com/communications
Computers and Peripherals	www.ti.com/computers
Consumer Electronics	www.ti.com/consumer-apps
Energy and Lighting	www.ti.com/energy
Industrial	www.ti.com/industrial
Medical	www.ti.com/medical
Security	www.ti.com/security
Space, Avionics and Defense	www.ti.com/space-avionics-defense
Video and Imaging	www.ti.com/video

TI E2E Community e2e.ti.com