

Distributed by:

JAMECO[®]
ELECTRONICS

www.Jameco.com ♦ 1-800-831-4242

The content and copyrights of the attached
material are the property of its owner.

Jameco Part Number 1135281

REGULATING PULSE WIDTH MODULATORS

FEATURES

- 8-V to 35-V Operation
- 5.1-V Reference Trimmed to 1%
- 100-Hz to 500-kHz Oscillator Range
- Separate Oscillator Sync Terminal
- Adjustable Deadtime Control
- Internal Soft-Start
- Pulse-by-Pulse Shutdown
- Input Undervoltage Lockout With Hysteresis
- Latching PWM to Prevent Multiple Pulses
- Dual Source/Sink Output Drivers

DESCRIPTION

The UC1525A/1527A series of pulse width modulator integrated circuits are designed to offer improved performance and lowered external parts count when used in designing all types of switching power supplies. The on-chip +5.1-V reference is trimmed to 1% and the input common-mode range of the error amplifier includes the reference voltage, eliminating external resistors. A sync input to the oscillator allows multiple units to be slaved or a single unit to be synchronized to an external system clock. A single resistor between the C_T and the discharge terminals provides a wide range of dead-time adjustment. These devices also feature built-in soft-start circuitry with only an external timing capacitor required. A shutdown terminal controls both the soft-start circuitry and the output stages, providing instantaneous turn off through the PWM latch with pulsed shutdown, as well as soft-start recycle with longer shutdown commands.

BLOCK DIAGRAM

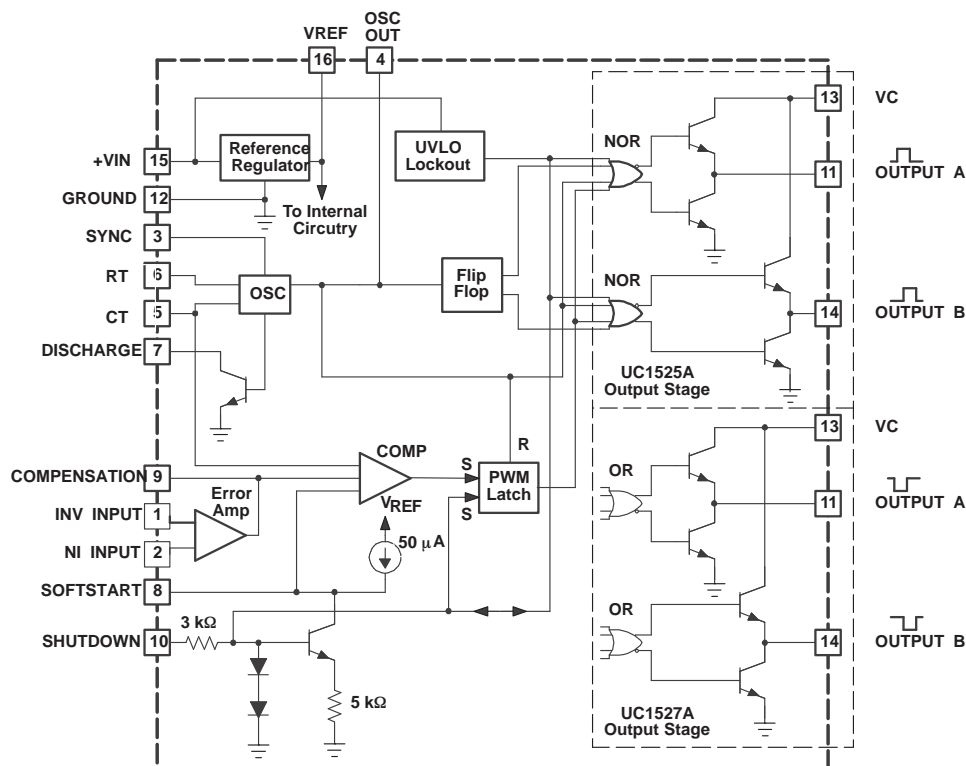

Please be aware that an important notice concerning availability, standard warranty, and use in critical applications of Texas Instruments semiconductor products and disclaimers thereto appears at the end of this data sheet.



These devices have limited built-in ESD protection. The leads should be shorted together or the device placed in conductive foam during storage or handling to prevent electrostatic damage to the MOS gates.

DESCRIPTION (continued)

These functions are also controlled by an undervoltage lockout which keeps the outputs off and the soft-start capacitor discharged for sub-normal input voltages. This lockout circuitry includes approximately 500 mV of hysteresis for jitter-free operation. Another feature of these PWM circuits is a latch following the comparator. Once a PWM pulse has been terminated for any reason, the outputs will remain off for the duration of the period. The latch is reset with each clock pulse. The output stages are totem-pole designs capable of sourcing or sinking in excess of 200 mA. The UC1525A output stage features NOR logic, giving a LOW output for an OFF state. The UC1527A utilizes OR logic which results in a HIGH output level when OFF.

ABSOLUTE MAXIMUM RATINGS⁽¹⁾

		UCx52xA	UNIT
+V _{IN}	Supply voltage	40	V
V _C	Collector supply voltage	40	
	Logic inputs	−0.3 to +5.5	
	Analog inputs	−0.3 to +V _{IN}	
	Output current, source or sink	500	mA
	Reference output current	50	
	Oscillator charging current	5	
	Power dissipation at T _A = +25°C ⁽²⁾	1000	mW
	Power dissipation at T _C = +25°C ⁽²⁾	2000	
	Operating junction temperature	−55 to 150	°C
	Storage temperature range	−65 to 150	
	Lead temperature (soldering, 10 seconds)	300	

(1) Values beyond which damage may occur.

(2) See Thermal Characteristics table.

RECOMMENDED OPERATING CONDITIONS⁽¹⁾

		MIN	MAX	UNIT	
+V _{IN}	Input voltage	8	35	V	
V _C	Collector supply voltage	4.5	35		
	Sink/source load current (steady state)	0	100	mA	
	Sink/source load current (peak)	0	400		
	Reference load current	0	20		
	Oscillator frequency range	100	400	Hz	
	Oscillator timing resistor	2	150	kΩ	
	Oscillator timing capacitorm	0.001	0.01	μF	
	Dead time resistor range	0	500	Ω	
	Operating ambient temperature range	UC1525A, UC1527A	−55	125	°C
		UC2525A, UC2527A	−25	85	
		UC3525A, UC3527A	0	70	

(1) Range over which the device is functional and parameter limits are assured.

THERMAL CHARACTERISTICS

over operating free-air temperature range (unless otherwise noted)

PACKAGE	θ_{JA}	θ_{JC}
J-16	80-120	28
N-16	90	45
DW-16	45-90	25
PLCC-20	43-75	34
LCC-20	70-80	20

CONNECTION DIAGRAMS

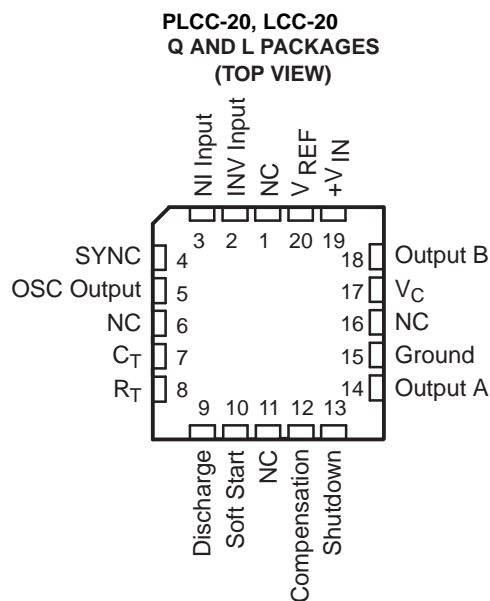
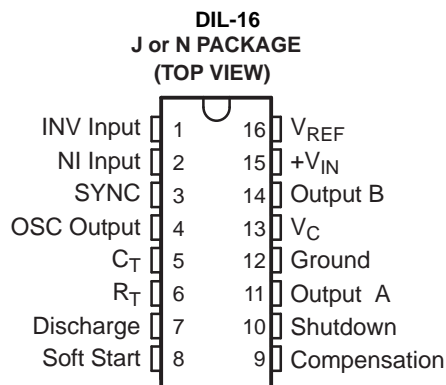

NC – No internal connection

ELECTRICAL CHARACTERISTICS

+V_{IN} = 20 V, and over operating temperature, unless otherwise specified, T_A = T_J

PARAMETER	TEST CONDITIONS	MIN	TYP	MAX	UNIT	
REFERENCE						
Output voltage	T _J = 25°C	UC152xA, UC252xA	5.05	5.10	5.15	V
		UC352xA	5.0	5.1	5.2	
Line regulation	V _{IN} = 8 V to 35 V		10	20	mV	
Load regulation	I _L = 0 mA to 20 mA		20	50		
Temperature stability ⁽¹⁾	Over operating range		20	50		
Total output variation ⁽¹⁾	Line, load, and temperature	UC152xA, UC252xA	5.0		5.2	V
		UC352xA	4.95		5.25	
Shorter circuit current	V _{REF} = 0, T _J = 25°C		80	100	mA	
Output noise Voltage ⁽¹⁾	10 Hz ≤ 10 kHz, T _J = 25°C		40	200	μVrms	
Long term stability ⁽¹⁾	T _J = 125°C		20	50	mV	
OSCILLATOR SECTION⁽²⁾						
Initial accuracy ^{(1) (2)}	T _J = 25°C		2%	6%		
Voltage stability ^{(1) (2)}	V _{IN} = 8 V to 35 V	UC152xA, UC252xA	0.3%	1%		
		UC352xA	1%	2%		
Temperature stability ⁽¹⁾	Over operating range		3%	6%		
Minimum frequency	R _T = 200 kΩ, C _T = 0.1 μF			120	Hz	
Maximum frequency	R _T = 2 kΩ, C _T = 470 pF	400			kHz	
Current mirror	I _{RT} = 2 mA	1.7	2.0	2.2	mA	
Clock amplitude ^{(1) (2)}		3.0	3.5		V	
Clock width ^{(1) (2)}	T _J = 25°C	0.3	0.5	1.0	μs	
Synchronization threshold ^{(1) (2)}		1.2	2.0	2.8	V	
Sync input current	Sync voltage = 3.5 V		1.0	2.5	mA	
ERROR AMPLIFIER SECTION (V_{CM} = 5.1 V)						
Input offset voltage		UC152xA, UC252xA	0.5	5	mV	
		UC352xA	2	10		
Input bias current			1	10	μA	
Input offset current				1		
DC open loop gain	R _L ≥ 10 MΩ	60	75		dB	
Gain-bandwidth product ⁽¹⁾	A _V = 0 dB, T _J = 25°C	1	2		MHz	
DC transconductanc ^{(1) (3)}	T _J = 25°C, 30 kΩ ≤ R _L ≤ 1 MΩ	1.1	1.5		mS	
Low-level output voltage			0.2	0.5	V	
High-level output voltage		3.8	5.6			
Common mode rejection	V _{CM} = 1.5 V to 5.2 V	60	75		dB	
Supply voltage rejection	V _{IN} = 8 V to 35 V	50	60			

(1) These parameters, although ensured over the recommended operating conditions, are not 100% tested in production.

(2) Tested at f_{OSC} = 40 kHz (R_T = 3.6 kΩ, C_T = 0.01 μF, R_D = 0. Approximate oscillator frequency is defined by:

$$f = \frac{1}{C_T(0.7R_T + 3R_D)}$$

(3) DC transconductance (g_M) relates to DC open-loop voltage gain (A_V) according to the following equation: A_V = g_MR_L where R_L is the resistance from pin 9 to ground. The minimum g_M specification is used to calculate minimum A_V when the error amplifier output is loaded.

ELECTRICAL CHARACTERISTICS (continued)

+V_{IN} = 20 V, and over operating temperature, unless otherwise specified, T_A = T_J

PARAMETER	TEST CONDITIONS	MIN	TYP	MAX	UNIT
PWM COMPARATOR					
Minimum duty-cycle				0%	
Maximum duty-cycle		45%	49%		
Input threshold ⁽⁴⁾	Zero duty-cycle	0.7	0.9		V
	Maximum duty-cycle		3.3	3.6	
Input bias current ⁽⁴⁾			0.05	1.0	μA
SHUTDOWN					
Soft-start current	V _{SD} = 0 V, V _{SS} = 0 V	25	50	80	μA
Soft-start low level	V _{SD} = 2.5 V		0.4	0.7	V
Shutdown threshold	To outputs, V _{SS} = 5.1 V, T _J = 25°C	0.6	0.8	1.0	
Shutdown input current	V _{SD} = 2.5 V		0.4	1.0	mA
Shutdown Delay ⁽⁵⁾	V _{SD} = 2.5 V, T _J = 25°C		0.2	0.5	μs
OUTPUT DRIVERS (each output) (V_C = 20 V)					
Low-level output voltage	I _{SINK} = 20 mA		0.2	0.4	V
	I _{SINK} = 100 mA		1.0	2.0	
High-level output voltage	I _{SOURCE} = 20 mA	18	19		
	I _{SOURCE} = 100 mA	17	18		
Undervoltage lockout	V _{COMP} and V _{SS} = High	6	7	8	
V _C OFF Current ⁽⁶⁾	V _C = 35 V			200	μA
Rise Time ⁽⁵⁾	C _L = 1 nF, T _J = 25°C		100	600	ns
Fall Time ⁽⁵⁾	C _L = 1 nF, T _J = 25°C		50	300	
TOTAL STANDBY CURRENT					
Supply Current	V _{IN} = 35 V		14	20	mA

(4) Tested at f_{OSC} = 40 kHz (R_T = 3.6 kΩ, C_T = 0.01 μF, R_D = 0 Ω).

(5) These parameters, although ensured over the recommended operating conditions, are not 100% tested in production.

(6) Collector off-state quiescent current measured at pin 13 with outputs low for UC1525A and high for UC1527A.

UC1525A Error Amplifier

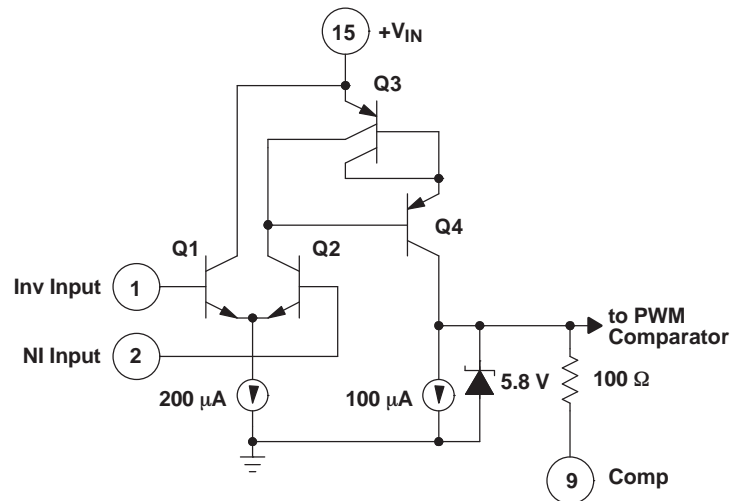

PRINCIPLES OF OPERATION AND TYPICAL CHARACTERISTICS

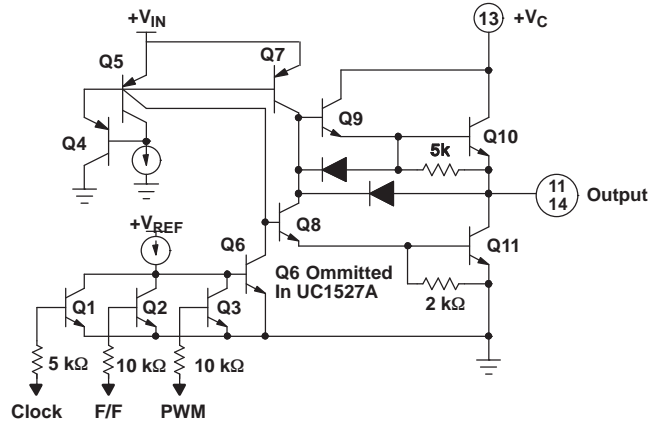

Figure 1. UC1525A Output Circuit (1/2 circuit shown)

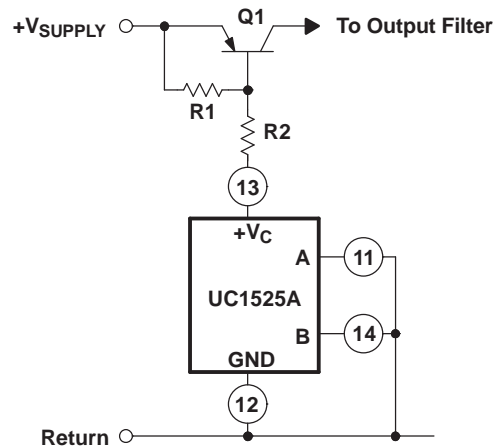

Figure 2. Grounded Driver Outputs For Single-Ended Supplies

For single-ended supplies, the driver outputs are grounded. The V_C terminal is switched to ground by the totem-pole source transistors on alternate oscillator cycles.

PRINCIPLES OF OPERATION AND TYPICAL CHARACTERISTICS (continued)

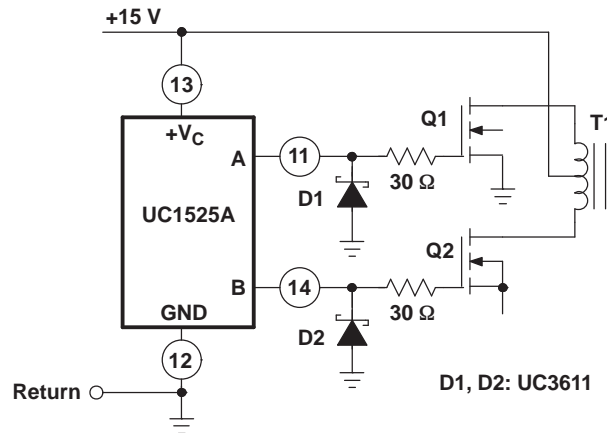

Figure 3. Output Drivers With Low Source Impedance

The low source impedance of the output drivers provides rapid charging of power FET input capacitance while minimizing external components.

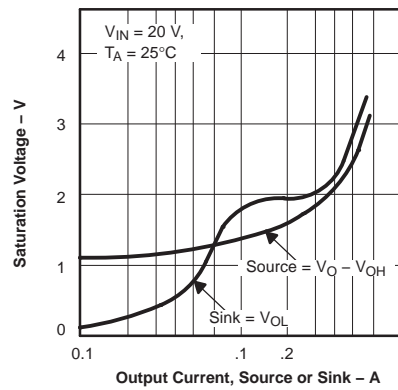

Figure 4. UC1525A Output Saturation Characteristics.

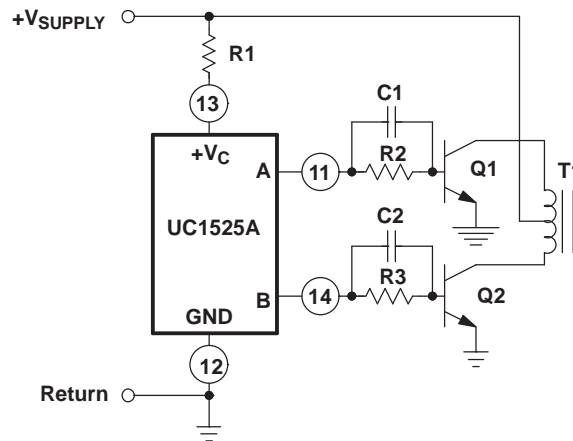

Figure 5. Conventional Push-Pull Bipolar Design

In conventional push-pull bipolar designs, forward base drive is controlled by R1–R3. Rapid turn-off times for the power devices are achieved with speed-up capacitors C1 and C2.

PRINCIPLES OF OPERATION AND TYPICAL CHARACTERISTICS (continued)

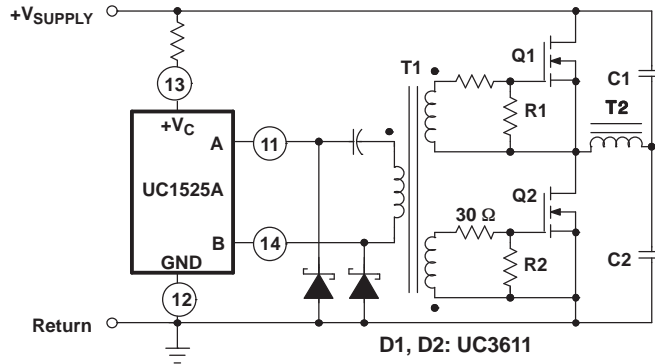

Figure 6. Low Power Transformers

Low power transformers can be driven by the UC1525A. Automatic reset occurs during dead time, when both ends of the primary winding are switched to ground.

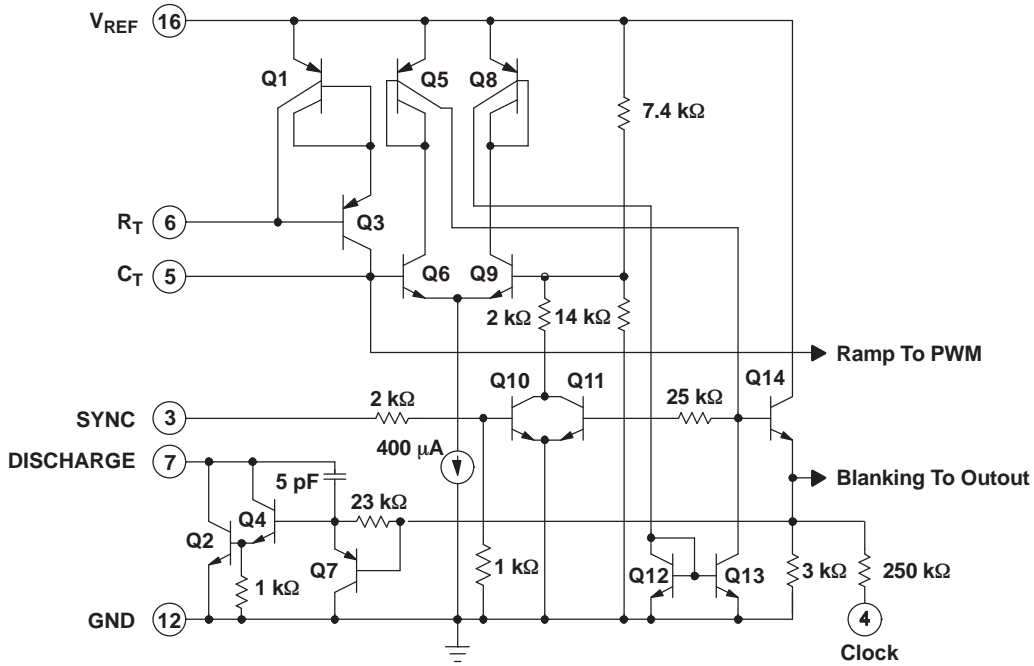

Figure 7. UC1525A Oscillator Schematic

PRINCIPLES OF OPERATION AND TYPICAL CHARACTERISTICS (continued)

Shutdown Options (See Block Diagram)

Since both the compensation and soft-start terminals (Pins 9 and 8) have current source pull-ups, either can readily accept a pull-down signal which only has to sink a maximum of 100 A to turn off the outputs. This is subject to the added requirement of discharging whatever external capacitance may be attached to these pins.

An alternate approach is the use of the shutdown circuitry of Pin 10 which has been improved to enhance the available shutdown options. Activating this circuit by applying a positive signal on Pin 10 performs two functions; the PWM latch is immediately set providing the fastest turn-off signal to the outputs; and a 150-A current sink begins to discharge the external soft-start capacitor. If the shutdown command is short, the PWM signal is terminated without significant discharge of the soft-start capacitor, thus, allowing, for example, a convenient implementation of pulse-by-pulse current limiting. Holding Pin 10 high for a longer duration, however, will ultimately discharge this external capacitor, recycling slow turn-on upon release.

Pin 10 should not be left floating as noise pickup could conceivably interrupt normal operation. All transitions of the voltage on pin 10 should be within the time frame of one clock cycle and not repeated at a frequency higher than 10 clock cycles.

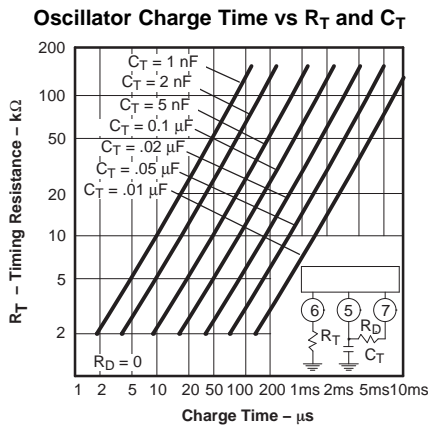

Figure 8.

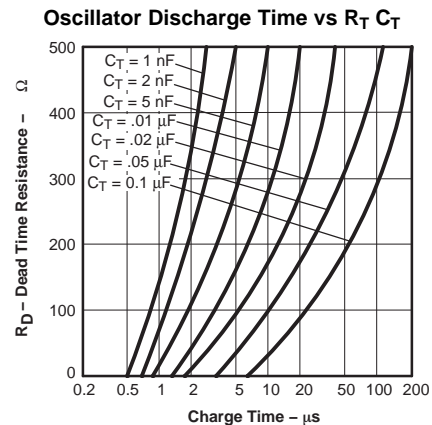

Figure 9.

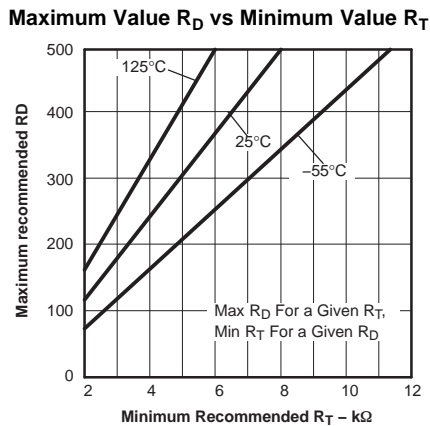

Figure 10.

Error Amplifier Voltage Gain and Phase vs Frequency

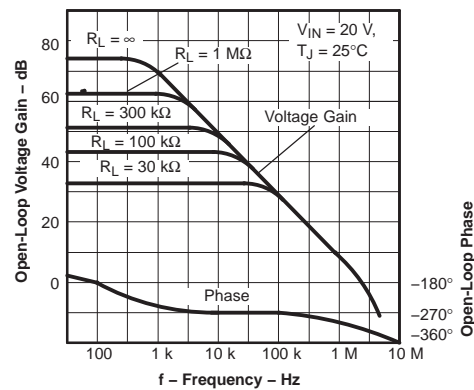

Figure 11.

PRINCIPLES OF OPERATION AND TYPICAL CHARACTERISTICS (continued)

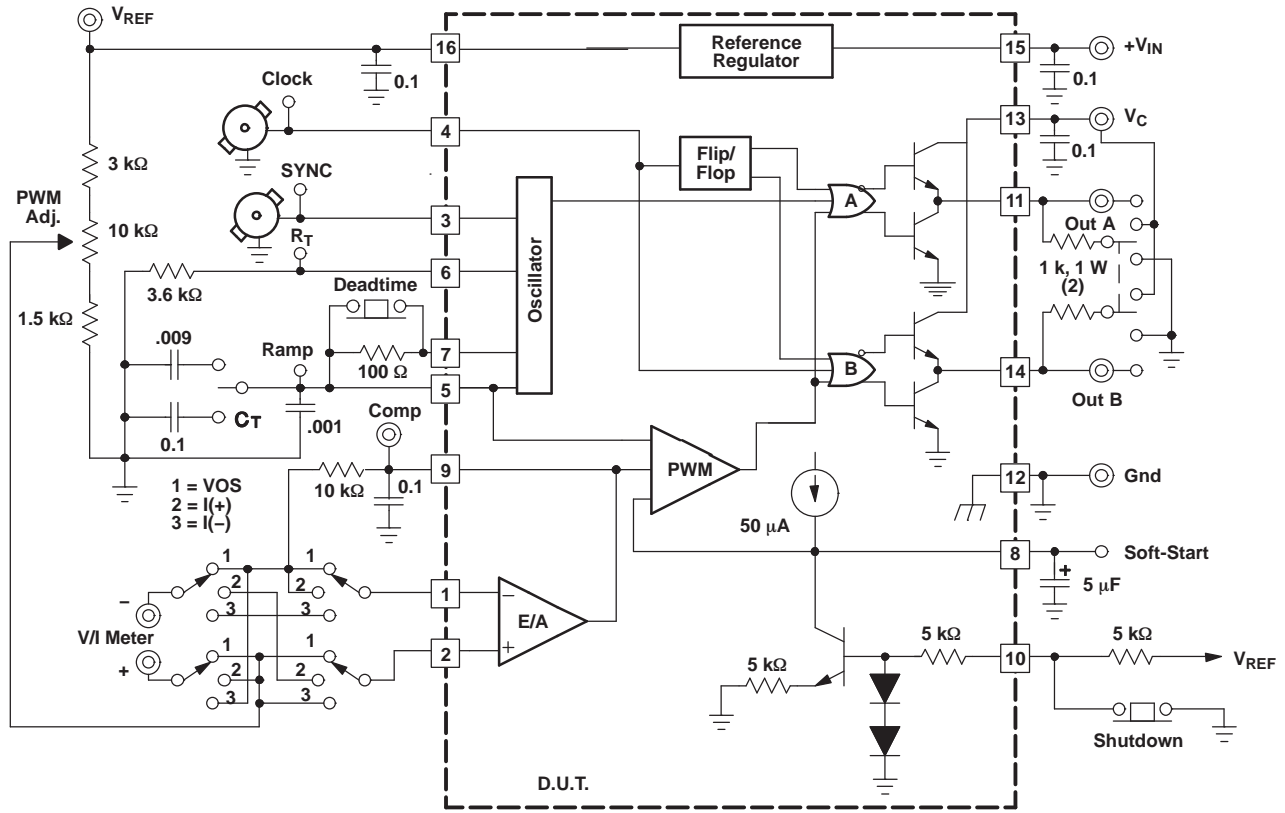

Figure 12. Lab Test Fixture

TAPE AND REEL INFORMATION



QUADRANT ASSIGNMENTS FOR PIN 1 ORIENTATION IN TAPE



*All dimensions are nominal

Device	Package Type	Package Drawing	Pins	SPQ	Reel Diameter (mm)	Reel Width W1 (mm)	A0 (mm)	B0 (mm)	K0 (mm)	P1 (mm)	W (mm)	Pin1 Quadrant
UC2525ADWTR	SOIC	DW	16	2000	330.0	16.4	10.85	10.8	2.7	12.0	16.0	Q1
UC3525ADWTR	SOIC	DW	16	2000	330.0	16.4	10.85	10.8	2.7	12.0	16.0	Q1

TAPE AND REEL BOX DIMENSIONS



*All dimensions are nominal

Device	Package Type	Package Drawing	Pins	SPQ	Length (mm)	Width (mm)	Height (mm)
UC2525ADWTR	SOIC	DW	16	2000	346.0	346.0	33.0
UC3525ADWTR	SOIC	DW	16	2000	346.0	346.0	33.0

IMPORTANT NOTICE

Texas Instruments Incorporated and its subsidiaries (TI) reserve the right to make corrections, modifications, enhancements, improvements, and other changes to its products and services at any time and to discontinue any product or service without notice. Customers should obtain the latest relevant information before placing orders and should verify that such information is current and complete. All products are sold subject to TI's terms and conditions of sale supplied at the time of order acknowledgment.

TI warrants performance of its hardware products to the specifications applicable at the time of sale in accordance with TI's standard warranty. Testing and other quality control techniques are used to the extent TI deems necessary to support this warranty. Except where mandated by government requirements, testing of all parameters of each product is not necessarily performed.

TI assumes no liability for applications assistance or customer product design. Customers are responsible for their products and applications using TI components. To minimize the risks associated with customer products and applications, customers should provide adequate design and operating safeguards.

TI does not warrant or represent that any license, either express or implied, is granted under any TI patent right, copyright, mask work right, or other TI intellectual property right relating to any combination, machine, or process in which TI products or services are used. Information published by TI regarding third-party products or services does not constitute a license from TI to use such products or services or a warranty or endorsement thereof. Use of such information may require a license from a third party under the patents or other intellectual property of the third party, or a license from TI under the patents or other intellectual property of TI.

Reproduction of TI information in TI data books or data sheets is permissible only if reproduction is without alteration and is accompanied by all associated warranties, conditions, limitations, and notices. Reproduction of this information with alteration is an unfair and deceptive business practice. TI is not responsible or liable for such altered documentation. Information of third parties may be subject to additional restrictions.

Resale of TI products or services with statements different from or beyond the parameters stated by TI for that product or service voids all express and any implied warranties for the associated TI product or service and is an unfair and deceptive business practice. TI is not responsible or liable for any such statements.

TI products are not authorized for use in safety-critical applications (such as life support) where a failure of the TI product would reasonably be expected to cause severe personal injury or death, unless officers of the parties have executed an agreement specifically governing such use. Buyers represent that they have all necessary expertise in the safety and regulatory ramifications of their applications, and acknowledge and agree that they are solely responsible for all legal, regulatory and safety-related requirements concerning their products and any use of TI products in such safety-critical applications, notwithstanding any applications-related information or support that may be provided by TI. Further, Buyers must fully indemnify TI and its representatives against any damages arising out of the use of TI products in such safety-critical applications.

TI products are neither designed nor intended for use in military/aerospace applications or environments unless the TI products are specifically designated by TI as military-grade or "enhanced plastic." Only products designated by TI as military-grade meet military specifications. Buyers acknowledge and agree that any such use of TI products which TI has not designated as military-grade is solely at the Buyer's risk, and that they are solely responsible for compliance with all legal and regulatory requirements in connection with such use.

TI products are neither designed nor intended for use in automotive applications or environments unless the specific TI products are designated by TI as compliant with ISO/TS 16949 requirements. Buyers acknowledge and agree that, if they use any non-designated products in automotive applications, TI will not be responsible for any failure to meet such requirements.

Following are URLs where you can obtain information on other Texas Instruments products and application solutions:

Products

Amplifiers	amplifier.ti.com
Data Converters	dataconverter.ti.com
DSP	dsp.ti.com
Clocks and Timers	www.ti.com/clocks
Interface	interface.ti.com
Logic	logic.ti.com
Power Mgmt	power.ti.com
Microcontrollers	microcontroller.ti.com
RFID	www.ti-rfid.com
RF/IF and ZigBee® Solutions	www.ti.com/lprf

Applications

Audio	www.ti.com/audio
Automotive	www.ti.com/automotive
Broadband	www.ti.com/broadband
Digital Control	www.ti.com/digitalcontrol
Medical	www.ti.com/medical
Military	www.ti.com/military
Optical Networking	www.ti.com/opticalnetwork
Security	www.ti.com/security
Telephony	www.ti.com/telephony
Video & Imaging	www.ti.com/video
Wireless	www.ti.com/wireless

Mailing Address: Texas Instruments, Post Office Box 655303, Dallas, Texas 75265
Copyright © 2008, Texas Instruments Incorporated