



Precision Low Dropout Linear Controllers

FEATURES

- Precision 1% Reference
- Over-Current Sense Threshold Accurate to 5%
- Programmable Duty-Ratio Over-Current Protection
- 4.5 V to 36 V Operation
- 100mA Output Drive, Source, or Sink
- Under-Voltage Lockout

Additional Features of the UC2832 series:

- Adjustable Current Limit to Current Sense Ratio
- Separate +VIN terminal
- Programmable Driver Current Limit
- Access to VREF and E/A(+)
- Logic-Level Disable Input

DESCRIPTION

The UC2832 and UC3833 series of precision linear regulators include all the control functions required in the design of very low dropout linear regulators. Additionally, they feature an innovative duty-ratio current limiting technique which provides peak load capability while limiting the average power dissipation of the external pass transistor during fault conditions. When the load current reaches an accurately programmed threshold, a gated-astable timer is enabled, which switches the regulator's pass device off and on at an externally programmable duty-ratio. During the on-time of the pass element, the output current is limited to a value slightly higher than the trip threshold of the duty-ratio timer. The constant-current-limit is programmable on the UCx832 to allow higher peak current during the on-time of the pass device. With duty-ratio control, high initial load demands and short circuit protection may both be accommodated without extra heat sinking or foldback current limiting. Additionally, if the timer pin is grounded, the duty-ratio timer is disabled, and the IC operates in constant-voltage/constant-current regulating mode.

These IC's include a 2 Volt ($\pm 1\%$) reference, error amplifier, UVLO, and a high current driver that has both source and sink outputs, allowing the use of either NPN or PNP external pass transistors. Safe operation is assured by the inclusion of under-voltage lockout (UVLO) and thermal shutdown.

The UC3833 family includes the basic functions of this design in a low-cost, 8-pin mini-dip package, while the UC2832 series provides added versatility with the availability of 14 pins. Packaging options include plastic (N suffix), or ceramic (J suffix). Specified operating temperature ranges are: commercial (0°C to 70°C), order UC3832/3 (N or J); and industrial (-40°C to 85°C), order UC2832/3 (N or J). Surface mount packaging is also available.

BLOCK DIAGRAMS

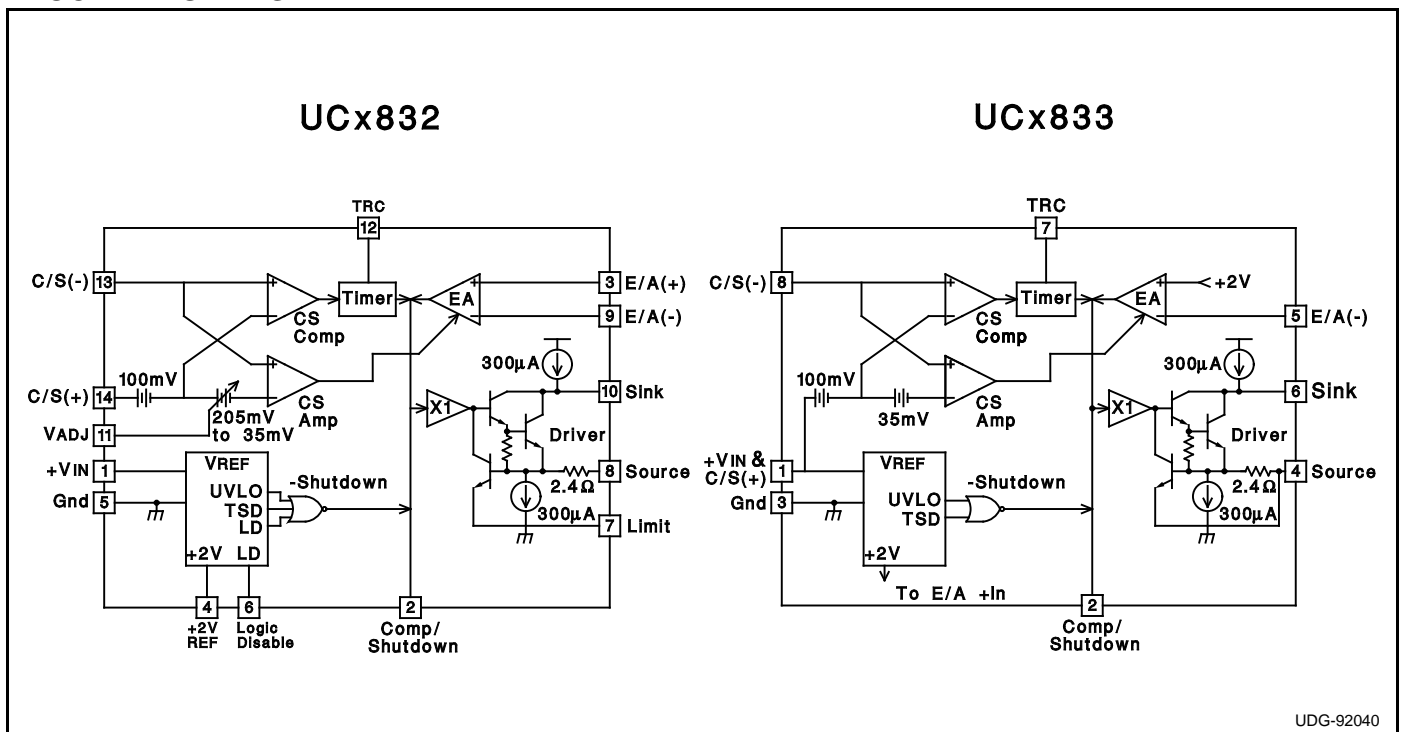

ABSOLUTE MAXIMUM RATINGS

Supply Voltage +VIN	40V
Driver Output Current (Sink or Source)	450mA
Driver Sink to Source Voltage	40V
TRC Pin Voltage	-0.3V to 3.2V
Other Input Voltages	-0.3V to +VIN
Operating Junction Temperature (note 2)	-55°C to +150°C
Storage Temperature	-65°C to +150°C
Lead Temperature (Soldering, 10 Seconds)	300°C

Note 1: Unless otherwise indicated, voltages are referenced to ground and currents are positive into, negative out of, the specified terminals.

Note 2: See Unitorde Integrated Circuits databook for information regarding thermal specifications and limitations of packages.

CONNECTION DIAGRAMS

UC2832

**DIL-14 (Top View)
J Or N Package**

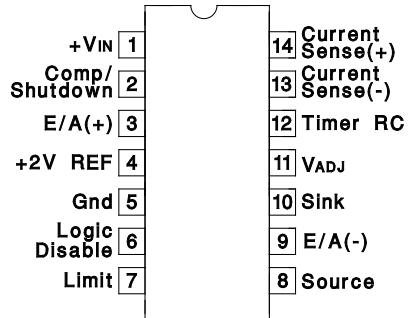

**SOIC-16 (Top View)
DW Package**

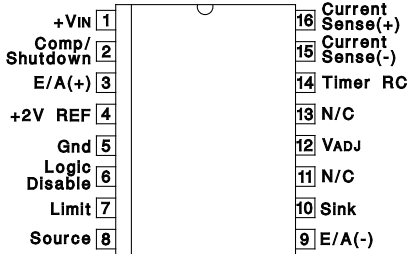

**LCC-20 & PLCC-20
L & Q Package
(Top View)**

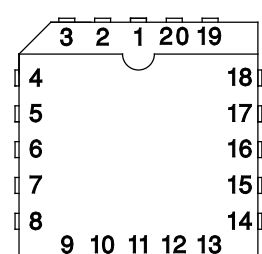

PACKAGE PIN FUNCTION	
FUNCTION	PIN
N/C	1
+VIN	2
Comp/Shutdown	3
E/A(+)	4
+2V REF	5
N/C	6
Gnd	7
Logic Disable	8
Limit	9
Source	10
N/C	11
E/A(-)	12
Sink	13
VADJ	14
N/C	15-17
Timer RC	18
Current Sense(-)	19
Current Sense(+)	20

UC3832

**DIL-8 (Top View)
J Or N Package**

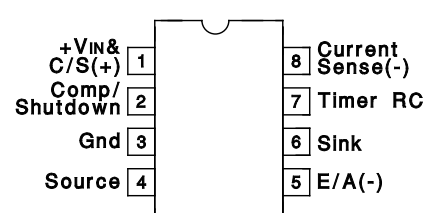

**SOIC-16 (Top View)
DW Package**

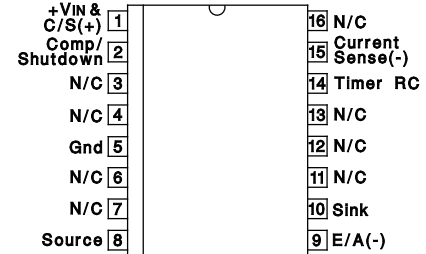

**LCC-20 & PLCC-20
L & Q Package
(Top View)**

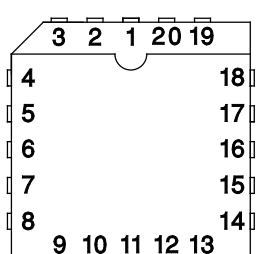

PACKAGE PIN FUNCTION	
FUNCTION	PIN
+VIN & C/S(+)	1
Comp/Shutdown	2
N/C	3
N/C	4
Gnd	5
N/C	6
N/C	7
Source	8
E/A(-)	9
Sink	10
N/C	11
N/C	12
N/C	13
Sink	15
Timer RC	16
Current Sense(+)	17
N/C	18-20

ELECTRICAL CHARACTERISTICS: Unless otherwise stated, specifications hold for
 $T_A = 0^\circ\text{C}$ to 70°C for the UC3832/3, -40°C to 85°C
for the UC2832/3, $+V_{IN} = 15\text{V}$, Driver sink = $+V_{IN}$, C/S(+) voltage = $+V_{IN}$. $T_A = T_J$.

PARAMETER	TEST CONDITIONS	MIN	TYP	MAX	UNITS
Input Supply					
Supply Current	$+V_{IN} = 6\text{V}$		6.5	10	mA
	$+V_{IN} = 36\text{V}$		9.5	15	mA
	Logic Disable = 2 V (UCx832 only)		3.3		mA
Reference Section					
Output Voltage (Note 3)	$T_J = 25^\circ\text{C}$, $I_{DRIVER} = 10\text{mA}$	1.98	2.00	2.02	V
	over temperature, $I_{DRIVER} = 10\text{mA}$	1.96	2.00	2.04	V
Load Regulation (UCx832 only)	$I_o = 0$ to 10m	-10	-5.0		mV
Line Regulation	$+V_{IN} = 4.5\text{V}$ to 36V , $I_{DRIVER} = 10\text{m}$		0.033	0.5	mV/V
Under-Voltage Lockout Threshold			3.6	4.5	V
Logic Disable Input (UCx832 only)					
Threshold Voltage		1.3	1.4	1.5	V
Input Bias Current	Logic Disable = 0 V	-5.0	-1.0		μA
Current Sense Section					
Comparator Offset		95	100	105	mV
	Over Temperature	93	100	107	mV
Amplifier Offset (UCx833 only)		110	135	170	mV
Amplifier Offset (UCx832 only)	$V_{ADJ} = \text{Open}$	110	135	170	mV
	$V_{ADJ} = 1\text{V}$	180	235	290	mV
	$V_{ADJ} = 0\text{V}$	250	305	360	mV
Input Bias Current	$V_{CM} = +V_{IN}$	65	100	135	μA
Input Offset Current (UCx832 only)	$V_{CM} = +V_{IN}$	-10		10	μA
Amplifier CMRR (UCx832 only)	$V_{CM} = 4.1\text{V}$ to $+V_{IN} + 0.3$		80		dB
Transconductance	$I_{COMP} = \pm 100\mu\text{A}$		6		mS
V_{ADJ} Input Current (UCx832 only)	$V_{ADJ} = 0\text{V}$	-10	-1		μA
Timer					
Inactive Leakage Current	$C/S(+) = C/S(-) = +V_{IN}$; TRC pin = 2 V		0.25	1.0	μA
Active Pullup Current	$C/S(+) = +V_{IN}$, $C/S(-) = +V_{IN} - 0.4\text{V}$; TRC pin = 0 V	-345	-270	-175	μA
Duty Ratio (note 4)	ontime/period, $R_T = 200\text{k}$, $C_T = 0.27\mu\text{F}$		4.8		%
Period (notes 4,5)	ontime + offtime, $R_T = 200\text{k}$, $C_T = 0.27\mu\text{F}$		36		ms
Upper Trip Threshold (V_u)			1.8		V
Lower Trip Threshold (V_l)			0.9		V
Trip Threshold Ratio	V_u/V_l		2.0		V/V
Error Amplifier					
Input Offset Voltage (UCx832 only)	$V_{CM} = V_{COMP} = 2\text{V}$	-8.0		8.0	mV
Input Bias Current	$V_{CM} = V_{COMP} = 2\text{V}$	-4.5	-1.1		μA
Input Offset Current (UCx832 only)	$V_{CM} = V_{COMP} = 2\text{V}$	-1.5		1.5	μA
AVOL	$V_{COMP} = 1\text{V}$ to 13V	50	70		dB
CMRR (UCx832 only)	$V_{CM} = 0\text{V}$ to $+V_{IN} - 3\text{V}$	60	80		dB
PSRR (UCx832 only)	$V_{CM} = 2\text{V}$, $+V_{IN} = 4.5\text{V}$ to 36		90		dB
Transconductance	$I_{COMP} = \pm 10\mu\text{A}$		43		mS
VOH	$I_{COMP} = 0$, Volts below $+V_{IN}$.95	1.3	V
VOL	$I_{COMP} = 0$.45	0.7	V
IOH	$V_{COMP} = 2\text{V}$	-700	-500	-100	μA

APPLICATION AND OPERATION INFORMATION (cont.)

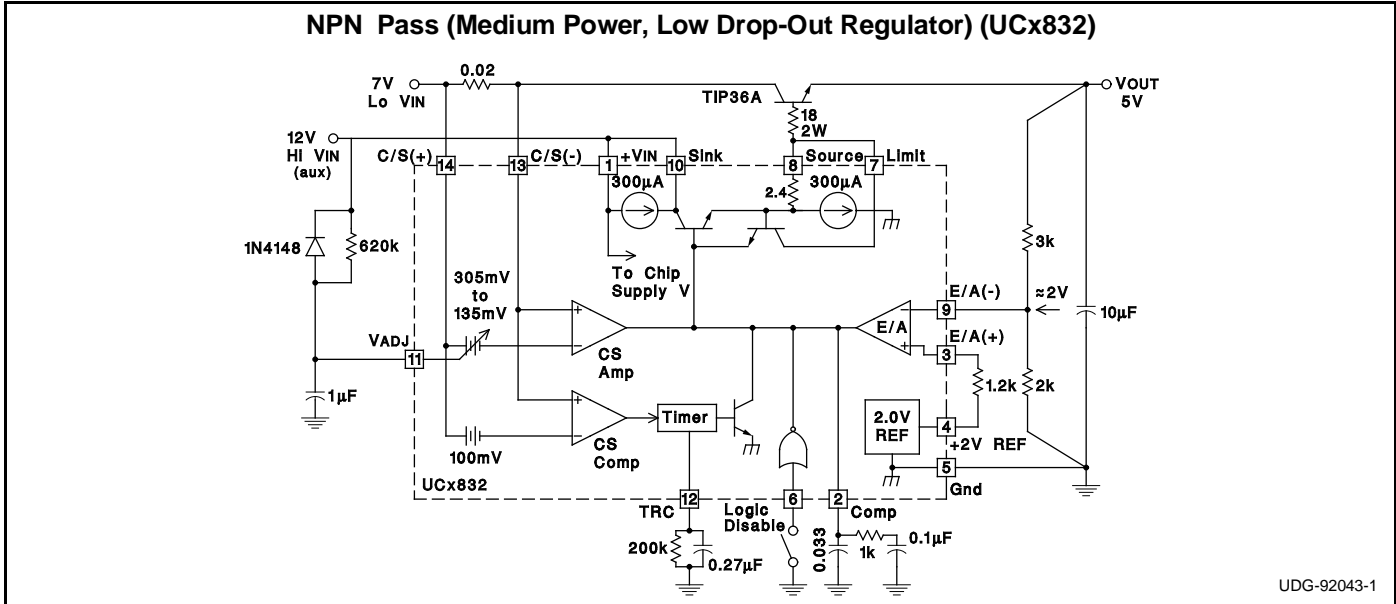
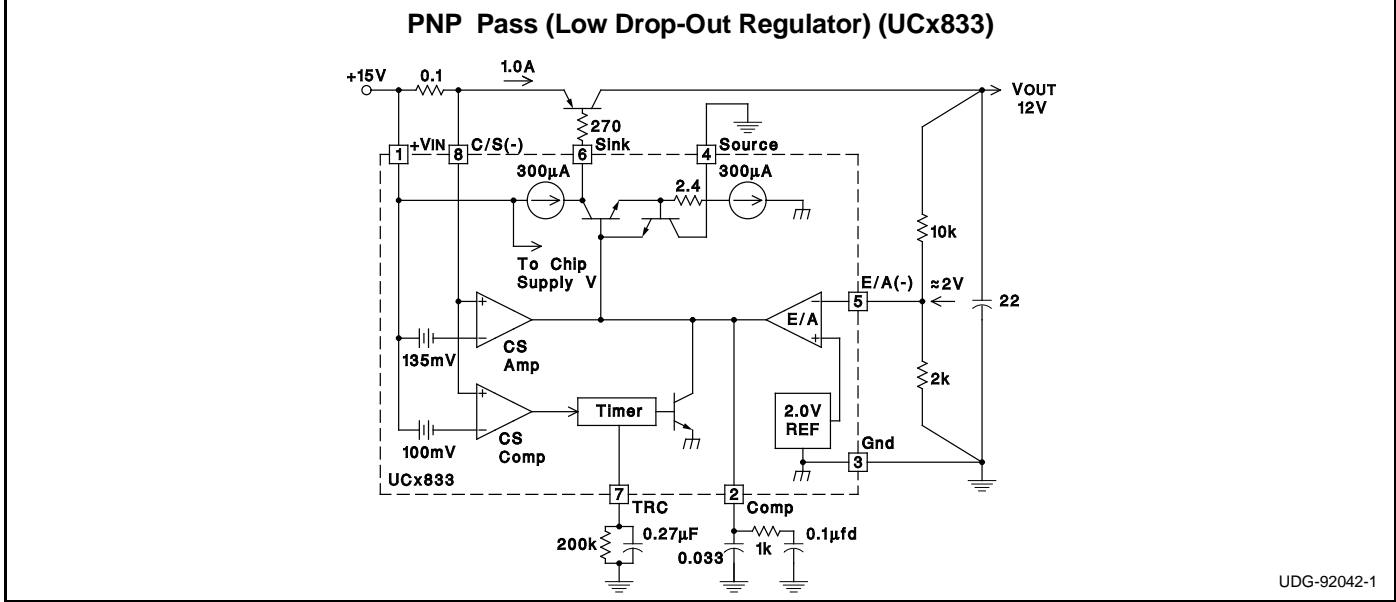

Estimating Maximum Load Capacitance

For any power supply, the rate at which the total output capacitance can be charged depends on the maximum output current available and on the nature of the load. For a constant-current current-limited power supply, the output will come up if the load asks for less than the maximum available short-circuit limit current.

To guarantee recovery of a duty-ratio current-limited power supply from a short-circuited load condition, there is a maximum total output capacitance which can be charged for a given unit ON time. The design value of ON time can be adjusted by changing the timing capacitor. Nominally, $T_{ON} = 0.693 \times 10k \times C_T$.

Typically, the IC regulates output current to a maximum of $I_{MAX} = K \times I_{TH}$, where I_{TH} is the timer trip-point current,

and
$$K = \frac{\text{Current Sense Amplifier Offset Voltage}}{100mA}$$

≈ 1.35 for UCx833, and is variable from 1.35 to 3.05 with V_{ADJ} for the UCx832.

For a worst-case constant-current load of value just less than I_{TH} , C_{MAX} can be estimated from:

$$C_{MAX} = ((K-1)I_{TH}) \left(\frac{T_{ON}}{V_{OUT}} \right),$$

where V_{OUT} is the nominal regulator output voltage.

For a resistive load of value R_L , the value of C_{MAX} can be estimated from:

$$C_{MAX} = \frac{T_{ON}}{R_L} \cdot \frac{1}{\ln \left[\left(1 - \frac{V_{OUT}}{K \cdot I_{TH} \cdot R_L} \right)^{-1} \right]}$$

APPLICATION AND OPERATION INFORMATION (cont.)

Current Sense Amplifier Offset Voltage vs VADJ

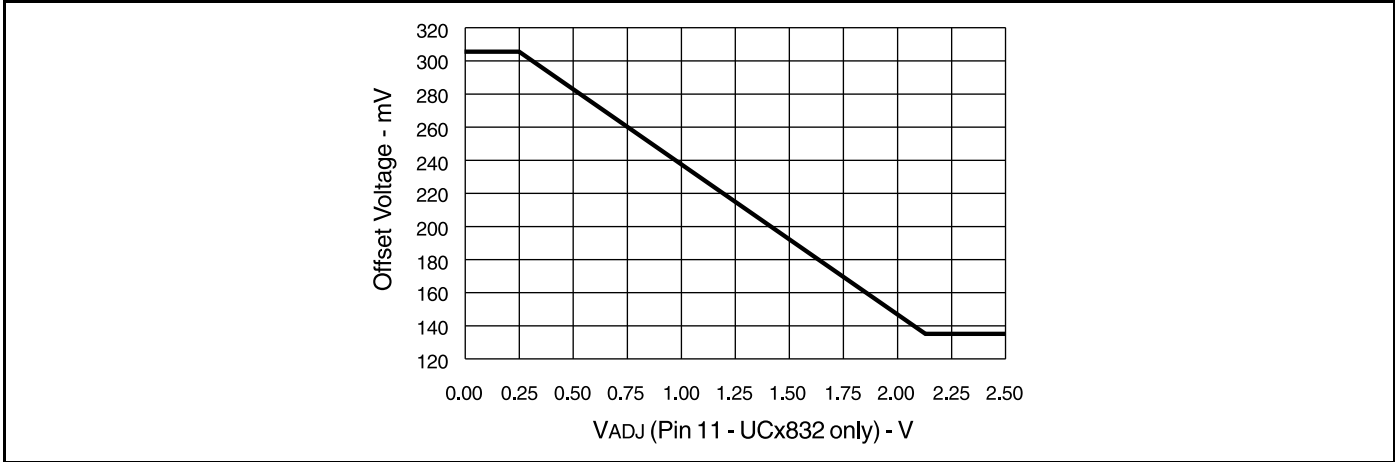

UCx832/33 Timer Function

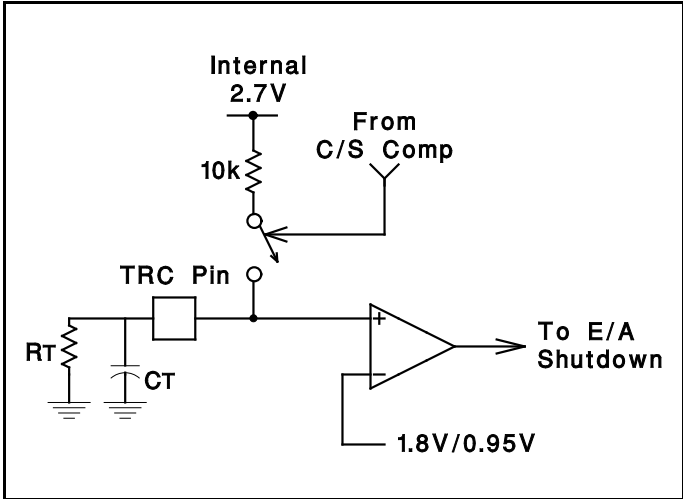

UCx832/33 Current Sense Input Configuration

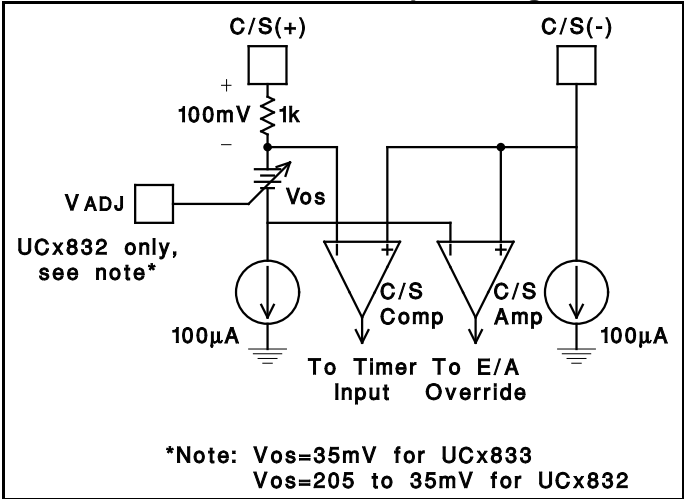

Load current, timing capacitor voltage, and output voltage of the regulator under fault conditions.

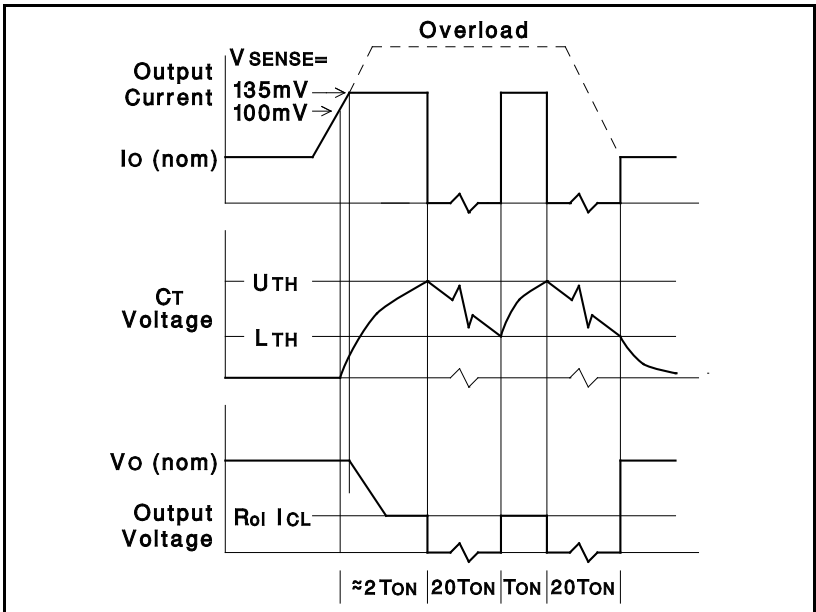

APPLICATION AND OPERATION INFORMATION (cont.)

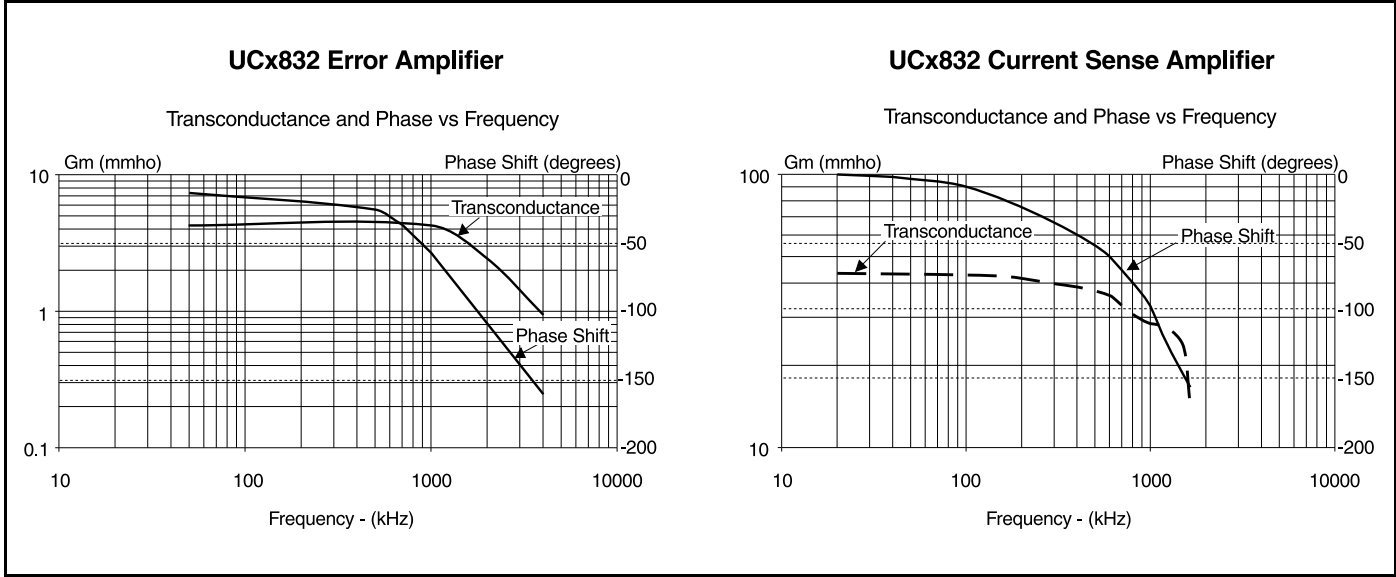
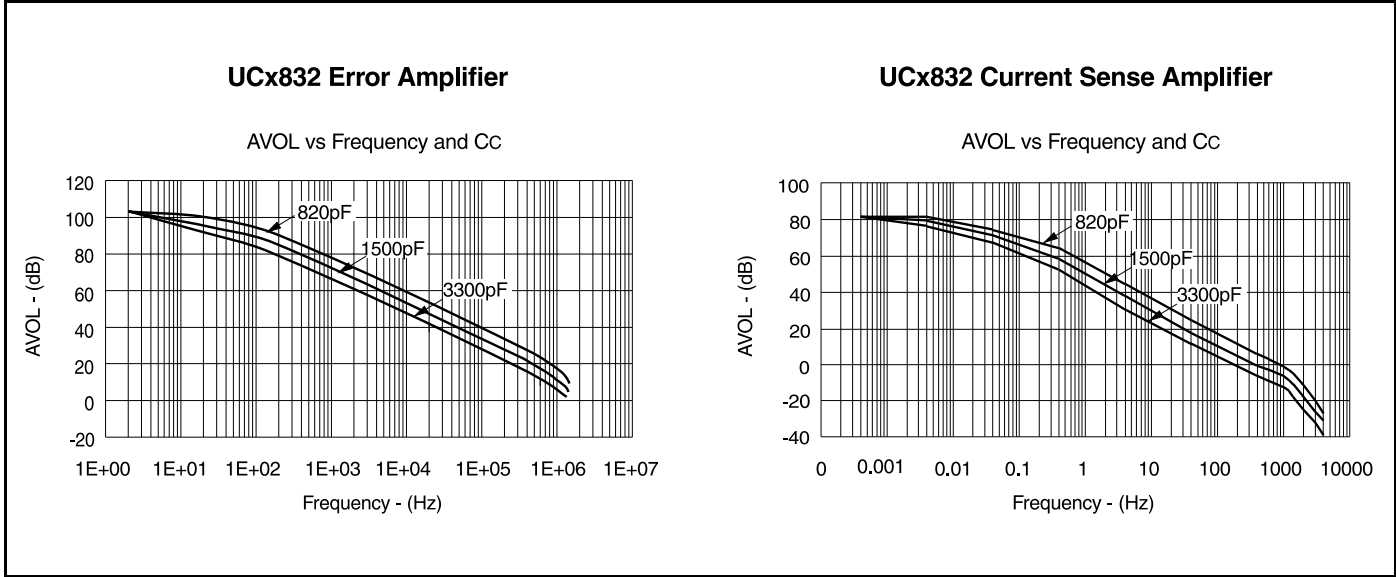

PACKAGING INFORMATION

Orderable Device	Status ⁽¹⁾	Package Type	Package Drawing	Pins	Package Qty	Eco Plan ⁽²⁾	Lead/ Ball Finish	MSL Peak Temp ⁽³⁾	Samples (Requires Login)
5962-9326501M2A	ACTIVE	LCCC	FK	20	1	TBD	Call TI	Call TI	
5962-9326501MCA	ACTIVE	CDIP	J	14	1	TBD	Call TI	Call TI	
5962-9326501V2A	ACTIVE	LCCC	FK	20	1	TBD	POST-PLATE	N / A for Pkg Type	
5962-9326501VCA	ACTIVE	CDIP	J	14	1	TBD	A42	N / A for Pkg Type	
UC1832J	ACTIVE	CDIP	J	14	1	TBD	A42	N / A for Pkg Type	
UC1832J883B	ACTIVE	CDIP	J	14	1	TBD	A42	N / A for Pkg Type	
UC1832L883B	ACTIVE	LCCC	FK	20	1	TBD	POST-PLATE	N / A for Pkg Type	
UC2832DW	ACTIVE	SOIC	DW	16	40	Green (RoHS & no Sb/Br)	CU NIPDAU	Level-2-260C-1 YEAR	
UC2832DWG4	ACTIVE	SOIC	DW	16	40	Green (RoHS & no Sb/Br)	CU NIPDAU	Level-2-260C-1 YEAR	
UC2832DWTR	ACTIVE	SOIC	DW	16	2000	Green (RoHS & no Sb/Br)	CU NIPDAU	Level-2-260C-1 YEAR	
UC2832DWTRG4	ACTIVE	SOIC	DW	16	2000	Green (RoHS & no Sb/Br)	CU NIPDAU	Level-2-260C-1 YEAR	
UC2833DW	ACTIVE	SOIC	DW	16	40	Green (RoHS & no Sb/Br)	CU NIPDAU	Level-2-260C-1 YEAR	
UC2833DWG4	ACTIVE	SOIC	DW	16	40	Green (RoHS & no Sb/Br)	CU NIPDAU	Level-2-260C-1 YEAR	
UC2833DWTR	ACTIVE	SOIC	DW	16	2000	Green (RoHS & no Sb/Br)	CU NIPDAU	Level-2-260C-1 YEAR	
UC2833DWTRG4	ACTIVE	SOIC	DW	16	2000	Green (RoHS & no Sb/Br)	CU NIPDAU	Level-2-260C-1 YEAR	
UC2833J	OBSOLETE	CDIP	JG	8		TBD	Call TI	Call TI	
UC2833N	ACTIVE	PDIP	P	8	50	Green (RoHS & no Sb/Br)	CU NIPDAU	N / A for Pkg Type	
UC2833NG4	ACTIVE	PDIP	P	8	50	Green (RoHS & no Sb/Br)	CU NIPDAU	N / A for Pkg Type	
UC3832DW	ACTIVE	SOIC	DW	16	40	Green (RoHS & no Sb/Br)	CU NIPDAU	Level-2-260C-1 YEAR	
UC3832DWG4	ACTIVE	SOIC	DW	16	40	Green (RoHS & no Sb/Br)	CU NIPDAU	Level-2-260C-1 YEAR	

Orderable Device	Status ⁽¹⁾	Package Type	Package Drawing	Pins	Package Qty	Eco Plan ⁽²⁾	Lead/ Ball Finish	MSL Peak Temp ⁽³⁾	Samples (Requires Login)
UC3832DWTR	ACTIVE	SOIC	DW	16	2000	Green (RoHS & no Sb/Br)	CU NIPDAU	Level-2-260C-1 YEAR	
UC3832DWTRG4	ACTIVE	SOIC	DW	16	2000	Green (RoHS & no Sb/Br)	CU NIPDAU	Level-2-260C-1 YEAR	
UC3832N	ACTIVE	PDIP	N	14	25	Green (RoHS & no Sb/Br)	CU NIPDAU	N / A for Pkg Type	
UC3832NG4	ACTIVE	PDIP	N	14	25	Green (RoHS & no Sb/Br)	CU NIPDAU	N / A for Pkg Type	
UC3833DW	ACTIVE	SOIC	DW	16	40	Green (RoHS & no Sb/Br)	CU NIPDAU	Level-2-260C-1 YEAR	
UC3833DWG4	ACTIVE	SOIC	DW	16	40	Green (RoHS & no Sb/Br)	CU NIPDAU	Level-2-260C-1 YEAR	
UC3833DWTR	ACTIVE	SOIC	DW	16	2000	Green (RoHS & no Sb/Br)	CU NIPDAU	Level-2-260C-1 YEAR	
UC3833DWTRG4	ACTIVE	SOIC	DW	16	2000	Green (RoHS & no Sb/Br)	CU NIPDAU	Level-2-260C-1 YEAR	
UC3833J	OBSOLETE	CDIP	JG	8		TBD	Call TI	Call TI	
UC3833N	ACTIVE	PDIP	P	8	50	Green (RoHS & no Sb/Br)	CU NIPDAU	N / A for Pkg Type	
UC3833NG4	ACTIVE	PDIP	P	8	50	Green (RoHS & no Sb/Br)	CU NIPDAU	N / A for Pkg Type	

⁽¹⁾ The marketing status values are defined as follows:

ACTIVE: Product device recommended for new designs.

LIFEBUY: TI has announced that the device will be discontinued, and a lifetime-buy period is in effect.

NRND: Not recommended for new designs. Device is in production to support existing customers, but TI does not recommend using this part in a new design.

PREVIEW: Device has been announced but is not in production. Samples may or may not be available.

OBSOLETE: TI has discontinued the production of the device.

⁽²⁾ Eco Plan - The planned eco-friendly classification: Pb-Free (RoHS), Pb-Free (RoHS Exempt), or Green (RoHS & no Sb/Br) - please check <http://www.ti.com/productcontent> for the latest availability information and additional product content details.

TBD: The Pb-Free/Green conversion plan has not been defined.

Pb-Free (RoHS): TI's terms "Lead-Free" or "Pb-Free" mean semiconductor products that are compatible with the current RoHS requirements for all 6 substances, including the requirement that lead not exceed 0.1% by weight in homogeneous materials. Where designed to be soldered at high temperatures, TI Pb-Free products are suitable for use in specified lead-free processes.

Pb-Free (RoHS Exempt): This component has a RoHS exemption for either 1) lead-based flip-chip solder bumps used between the die and package, or 2) lead-based die adhesive used between the die and leadframe. The component is otherwise considered Pb-Free (RoHS compatible) as defined above.

Green (RoHS & no Sb/Br): TI defines "Green" to mean Pb-Free (RoHS compatible), and free of Bromine (Br) and Antimony (Sb) based flame retardants (Br or Sb do not exceed 0.1% by weight in homogeneous material)

⁽³⁾ MSL, Peak Temp. -- The Moisture Sensitivity Level rating according to the JEDEC industry standard classifications, and peak solder temperature.

Important Information and Disclaimer: The information provided on this page represents TI's knowledge and belief as of the date that it is provided. TI bases its knowledge and belief on information provided by third parties, and makes no representation or warranty as to the accuracy of such information. Efforts are underway to better integrate information from third parties. TI has taken and continues to take reasonable steps to provide representative and accurate information but may not have conducted destructive testing or chemical analysis on incoming materials and chemicals. TI and TI suppliers consider certain information to be proprietary, and thus CAS numbers and other limited information may not be available for release.

In no event shall TI's liability arising out of such information exceed the total purchase price of the TI part(s) at issue in this document sold by TI to Customer on an annual basis.

OTHER QUALIFIED VERSIONS OF UC1832, UC1832-SP, UC2832, UC3832, UC3833 :

- Catalog: [UC3832](#), [UC1832](#)
- Enhanced Product: [UC2832-EP](#)
- Military: [UC1832](#), [UC1833](#)
- Space: [UC1832-SP](#)

NOTE: Qualified Version Definitions:

- Catalog - TI's standard catalog product
- Enhanced Product - Supports Defense, Aerospace and Medical Applications
- Military - QML certified for Military and Defense Applications
- Space - Radiation tolerant, ceramic packaging and qualified for use in Space-based application

TAPE AND REEL INFORMATION
REEL DIMENSIONS

TAPE DIMENSIONS

A0	Dimension designed to accommodate the component width
B0	Dimension designed to accommodate the component length
K0	Dimension designed to accommodate the component thickness
W	Overall width of the carrier tape
P1	Pitch between successive cavity centers

TAPE AND REEL INFORMATION

*All dimensions are nominal

Device	Package Type	Package Drawing	Pins	SPQ	Reel Diameter (mm)	Reel Width W1 (mm)	A0 (mm)	B0 (mm)	K0 (mm)	P1 (mm)	W (mm)	Pin1 Quadrant
UC2832DWTR	SOIC	DW	16	2000	330.0	16.4	10.75	10.7	2.7	12.0	16.0	Q1
UC2833DWTR	SOIC	DW	16	2000	330.0	16.4	10.75	10.7	2.7	12.0	16.0	Q1
UC3832DWTR	SOIC	DW	16	2000	330.0	16.4	10.75	10.7	2.7	12.0	16.0	Q1
UC3833DWTR	SOIC	DW	16	2000	330.0	16.4	10.75	10.7	2.7	12.0	16.0	Q1

TAPE AND REEL BOX DIMENSIONS

*All dimensions are nominal

Device	Package Type	Package Drawing	Pins	SPQ	Length (mm)	Width (mm)	Height (mm)
UC2832DWTR	SOIC	DW	16	2000	367.0	367.0	38.0
UC2833DWTR	SOIC	DW	16	2000	367.0	367.0	38.0
UC3832DWTR	SOIC	DW	16	2000	367.0	367.0	38.0
UC3833DWTR	SOIC	DW	16	2000	367.0	367.0	38.0

JG (R-GDIP-T8)

CERAMIC DUAL-IN-LINE

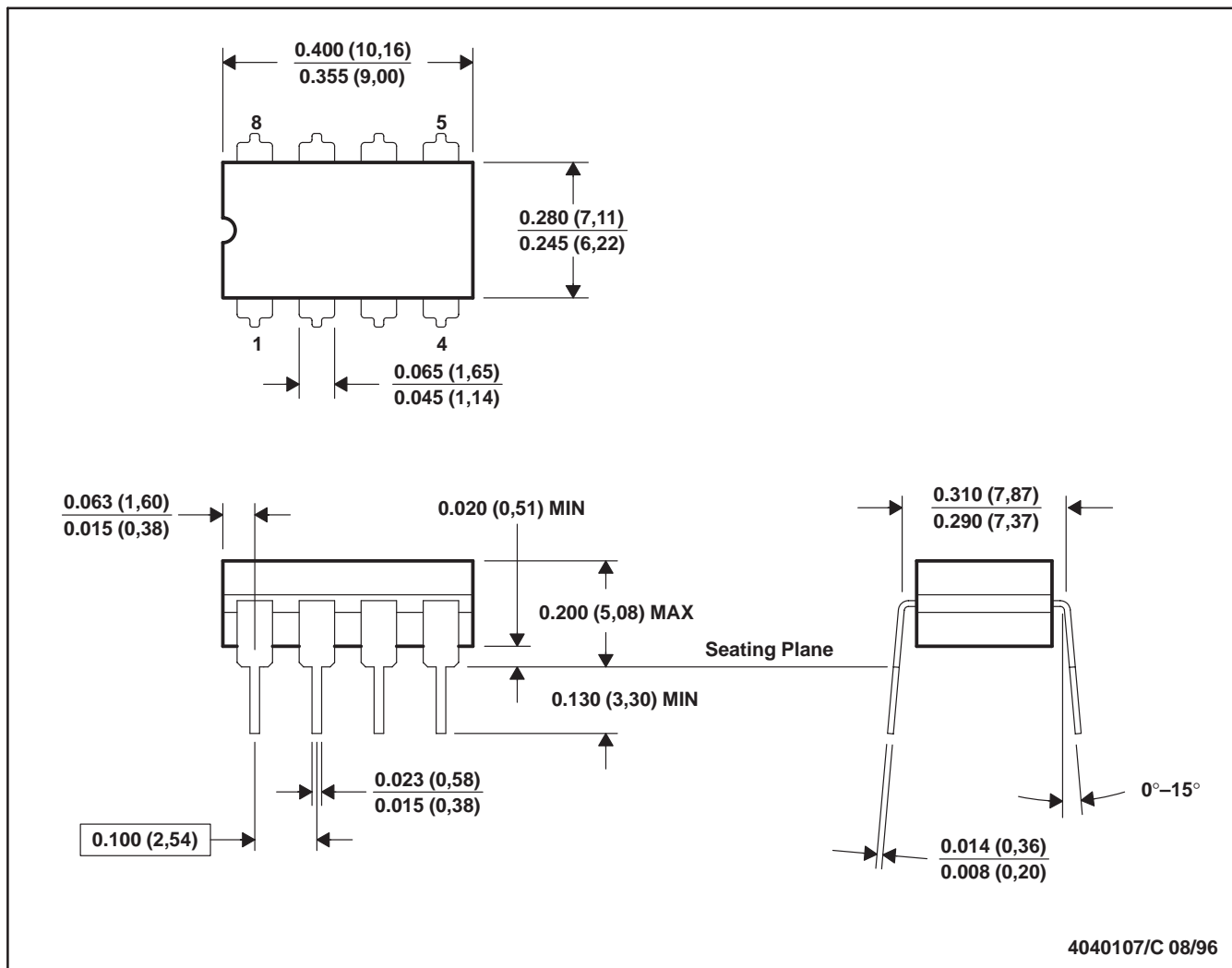

- NOTES: A. All linear dimensions are in inches (millimeters).
 B. This drawing is subject to change without notice.
 C. This package can be hermetically sealed with a ceramic lid using glass frit.
 D. Index point is provided on cap for terminal identification.
 E. Falls within MIL STD 1835 GDIP1-T8

J (R-GDIP-T**)

14 LEADS SHOWN

CERAMIC DUAL IN-LINE PACKAGE



DIM \ PINS **	14	16	18	20
A	0.300 (7,62) BSC	0.300 (7,62) BSC	0.300 (7,62) BSC	0.300 (7,62) BSC
B MAX	0.785 (19,94)	.840 (21,34)	0.960 (24,38)	1.060 (26,92)
B MIN	—	—	—	—
C MAX	0.300 (7,62)	0.300 (7,62)	0.310 (7,87)	0.300 (7,62)
C MIN	0.245 (6,22)	0.245 (6,22)	0.220 (5,59)	0.245 (6,22)



4040083/F 03/03

- NOTES:
- All linear dimensions are in inches (millimeters).
 - This drawing is subject to change without notice.
 - This package is hermetically sealed with a ceramic lid using glass frit.
 - Index point is provided on cap for terminal identification only on press ceramic glass frit seal only.
 - Falls within MIL STD 1835 GDIP1-T14, GDIP1-T16, GDIP1-T18 and GDIP1-T20.

FK (S-CQCC-N**)

LEADLESS CERAMIC CHIP CARRIER

28 TERMINAL SHOWN

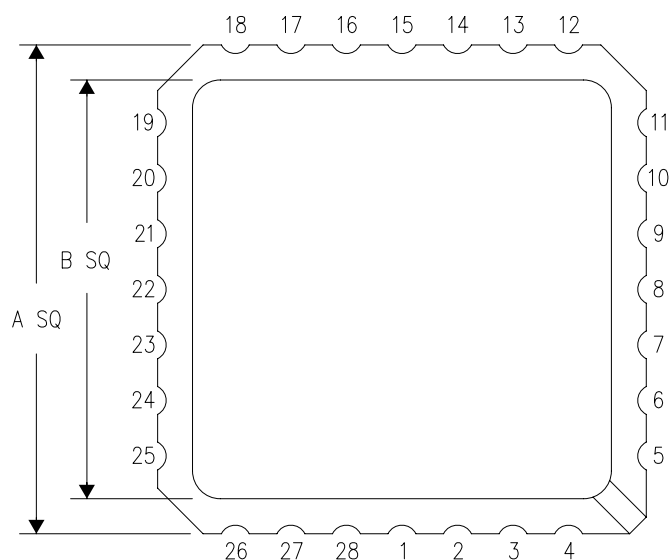

NO. OF TERMINALS **	A		B	
	MIN	MAX	MIN	MAX
20	0.342 (8,69)	0.358 (9,09)	0.307 (7,80)	0.358 (9,09)
28	0.442 (11,23)	0.458 (11,63)	0.406 (10,31)	0.458 (11,63)
44	0.640 (16,26)	0.660 (16,76)	0.495 (12,58)	0.560 (14,22)
52	0.740 (18,78)	0.761 (19,32)	0.495 (12,58)	0.560 (14,22)
68	0.938 (23,83)	0.962 (24,43)	0.850 (21,6)	0.858 (21,8)
84	1.141 (28,99)	1.165 (29,59)	1.047 (26,6)	1.063 (27,0)

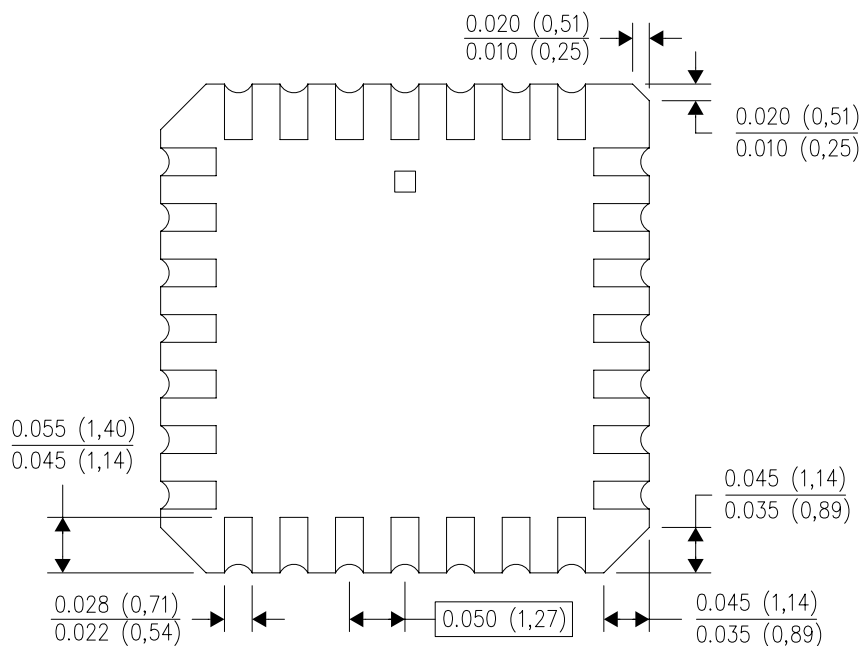

4040140/D 01/11

- NOTES:
- All linear dimensions are in inches (millimeters).
 - This drawing is subject to change without notice.
 - This package can be hermetically sealed with a metal lid.
 - Falls within JEDEC MS-004

P (R-PDIP-T8)

PLASTIC DUAL-IN-LINE PACKAGE



- NOTES:
- A. All linear dimensions are in inches (millimeters).
 - B. This drawing is subject to change without notice.
 - C. Falls within JEDEC MS-001 variation BA.

N (R-PDIP-T**)

PLASTIC DUAL-IN-LINE PACKAGE

16 PINS SHOWN



- NOTES:
- A. All linear dimensions are in inches (millimeters).
 - B. This drawing is subject to change without notice.
 - Falls within JEDEC MS-001, except 18 and 20 pin minimum body length (Dim A).
 - The 20 pin end lead shoulder width is a vendor option, either half or full width.

DW (R-PDSO-G16)

PLASTIC SMALL OUTLINE



- NOTES:
- A. All linear dimensions are in inches (millimeters). Dimensioning and tolerancing per ASME Y14.5M-1994.
 - B. This drawing is subject to change without notice.
 - C. Body dimensions do not include mold flash or protrusion not to exceed 0.006 (0,15).
 - D. Falls within JEDEC MS-013 variation AA.

DW (R-PDSO-G16)

PLASTIC SMALL OUTLINE

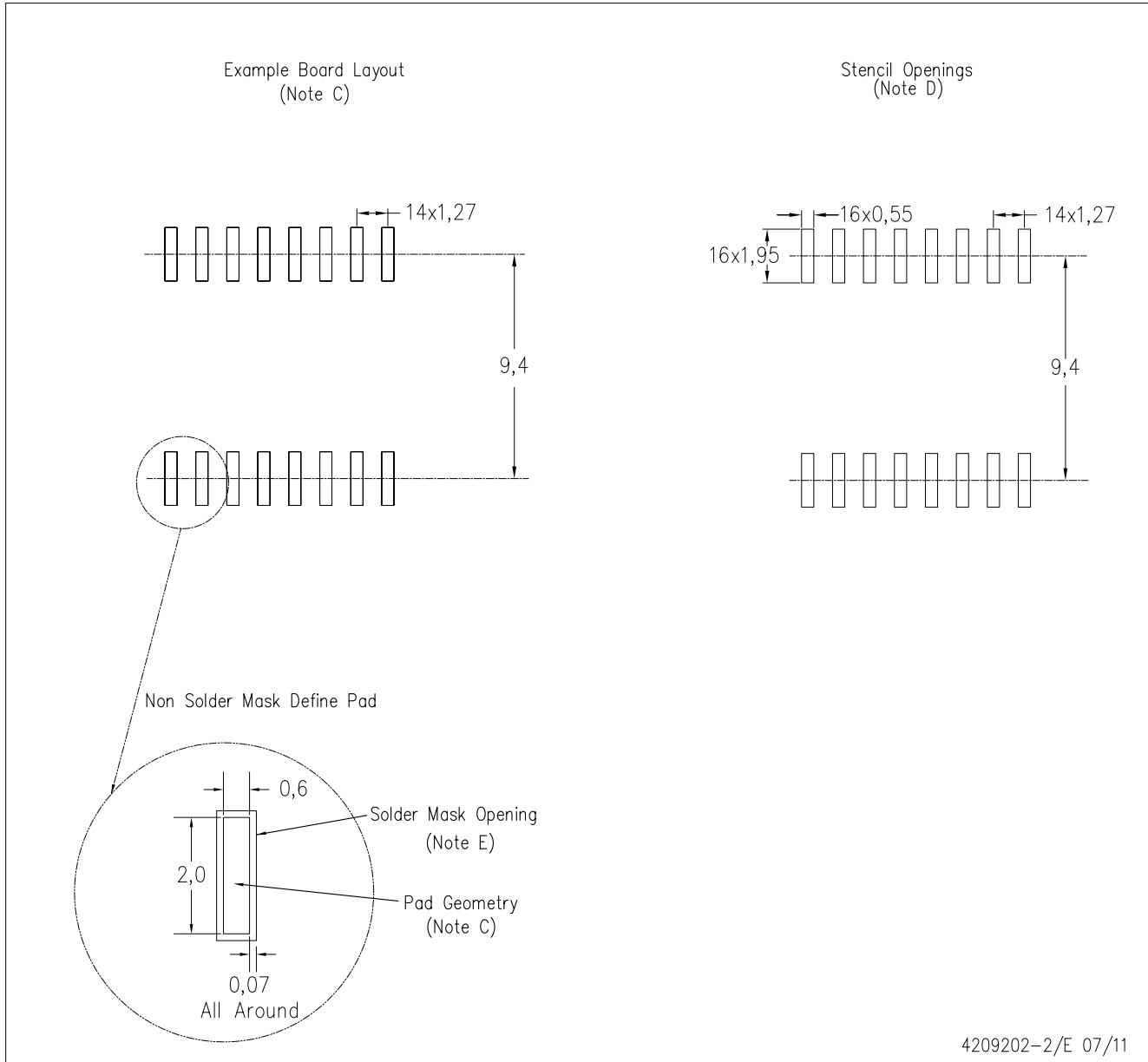

4209202-2/E 07/11

- NOTES:
- A. All linear dimensions are in millimeters.
 - B. This drawing is subject to change without notice.
 - C. Refer to IPC7351 for alternate board design.
 - D. Laser cutting apertures with trapezoidal walls and also rounding corners will offer better paste release. Customers should contact their board assembly site for stencil design recommendations. Refer to IPC-7525
 - E. Customers should contact their board fabrication site for solder mask tolerances between and around signal pads.

IMPORTANT NOTICE

Texas Instruments Incorporated and its subsidiaries (TI) reserve the right to make corrections, enhancements, improvements and other changes to its semiconductor products and services per JESD46, latest issue, and to discontinue any product or service per JESD48, latest issue. Buyers should obtain the latest relevant information before placing orders and should verify that such information is current and complete. All semiconductor products (also referred to herein as "components") are sold subject to TI's terms and conditions of sale supplied at the time of order acknowledgment.

TI warrants performance of its components to the specifications applicable at the time of sale, in accordance with the warranty in TI's terms and conditions of sale of semiconductor products. Testing and other quality control techniques are used to the extent TI deems necessary to support this warranty. Except where mandated by applicable law, testing of all parameters of each component is not necessarily performed.

TI assumes no liability for applications assistance or the design of Buyers' products. Buyers are responsible for their products and applications using TI components. To minimize the risks associated with Buyers' products and applications, Buyers should provide adequate design and operating safeguards.

TI does not warrant or represent that any license, either express or implied, is granted under any patent right, copyright, mask work right, or other intellectual property right relating to any combination, machine, or process in which TI components or services are used. Information published by TI regarding third-party products or services does not constitute a license to use such products or services or a warranty or endorsement thereof. Use of such information may require a license from a third party under the patents or other intellectual property of the third party, or a license from TI under the patents or other intellectual property of TI.

Reproduction of significant portions of TI information in TI data books or data sheets is permissible only if reproduction is without alteration and is accompanied by all associated warranties, conditions, limitations, and notices. TI is not responsible or liable for such altered documentation. Information of third parties may be subject to additional restrictions.

Resale of TI components or services with statements different from or beyond the parameters stated by TI for that component or service voids all express and any implied warranties for the associated TI component or service and is an unfair and deceptive business practice. TI is not responsible or liable for any such statements.

Buyer acknowledges and agrees that it is solely responsible for compliance with all legal, regulatory and safety-related requirements concerning its products, and any use of TI components in its applications, notwithstanding any applications-related information or support that may be provided by TI. Buyer represents and agrees that it has all the necessary expertise to create and implement safeguards which anticipate dangerous consequences of failures, monitor failures and their consequences, lessen the likelihood of failures that might cause harm and take appropriate remedial actions. Buyer will fully indemnify TI and its representatives against any damages arising out of the use of any TI components in safety-critical applications.

In some cases, TI components may be promoted specifically to facilitate safety-related applications. With such components, TI's goal is to help enable customers to design and create their own end-product solutions that meet applicable functional safety standards and requirements. Nonetheless, such components are subject to these terms.

No TI components are authorized for use in FDA Class III (or similar life-critical medical equipment) unless authorized officers of the parties have executed a special agreement specifically governing such use.

Only those TI components which TI has specifically designated as military grade or "enhanced plastic" are designed and intended for use in military/aerospace applications or environments. Buyer acknowledges and agrees that any military or aerospace use of TI components which have **not** been so designated is solely at the Buyer's risk, and that Buyer is solely responsible for compliance with all legal and regulatory requirements in connection with such use.

TI has specifically designated certain components which meet ISO/TS16949 requirements, mainly for automotive use. Components which have not been so designated are neither designed nor intended for automotive use; and TI will not be responsible for any failure of such components to meet such requirements.

Products

Audio	www.ti.com/audio
Amplifiers	amplifier.ti.com
Data Converters	dataconverter.ti.com
DLP® Products	www.dlp.com
DSP	dsp.ti.com
Clocks and Timers	www.ti.com/clocks
Interface	interface.ti.com
Logic	logic.ti.com
Power Mgmt	power.ti.com
Microcontrollers	microcontroller.ti.com
RFID	www.ti-rfid.com
OMAP Applications Processors	www.ti.com/omap
Wireless Connectivity	www.ti.com/wirelessconnectivity

Applications

Automotive and Transportation	www.ti.com/automotive
Communications and Telecom	www.ti.com/communications
Computers and Peripherals	www.ti.com/computers
Consumer Electronics	www.ti.com/consumer-apps
Energy and Lighting	www.ti.com/energy
Industrial	www.ti.com/industrial
Medical	www.ti.com/medical
Security	www.ti.com/security
Space, Avionics and Defense	www.ti.com/space-avionics-defense
Video and Imaging	www.ti.com/video

TI E2E Community

e2e.ti.com