

UC1842A-EP, UC1843A-EP, UC1844A-EP, UC1845A-EP CURRENT-MODE PWM CONTROLLER

SGLS134C – SEPTEMBER 2002 – REVISED FEBRUARY 2006

- **Controlled Baseline**
 - One Assembly/Test Site, One Fabrication Site
- **Extended Temperature Performance of –55°C to 125°C**
- **Enhanced Diminishing Manufacturing Sources (DMS) Support**
- **Enhanced Product Change Notification**
- **Qualification Pedigree†**
- **Optimized for Off-line and DC-to-DC Converters**
- **Low Start Up Current (<0.5 mA)**
- **Trimmed Oscillator Discharge Current**
- **Automatic Feed Forward Compensation**
- **Pulse-by-Pulse Current Limiting**
- **Enhanced Load Response Characteristics**
- **Under-Voltage Lockout With Hysteresis**
- **Double Pulse Suppression**
- **High Current Totem Pole Output**
- **Internally Trimmed Bandgap Reference**
- **500 kHz Operation**
- **Low R_O Error Amp**

† Component qualification in accordance with JEDEC and industry standards to ensure reliable operation over an extended temperature range. This includes, but is not limited to, Highly Accelerated Stress Test (HAST) or biased 85/85, temperature cycle, autoclave or unbiased HAST, electromigration, bond intermetallic life, and mold compound life. Such qualification testing should not be viewed as justifying use of this component beyond specified performance and environmental limits.

D PACKAGE
(TOP VIEW)

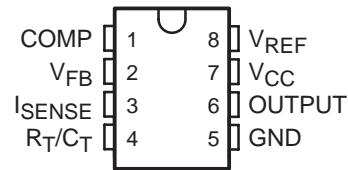

description

The UC1842A/3A/4A/5A family of control ICs is a pin-for-pin compatible improved version of the UC3842/3/4/5 family. Providing the necessary features to control current mode switched mode power supplies, this family has the following improved features. Start up current is guaranteed to be less than 0.5 mA. Oscillator discharge is trimmed to 8.3 mA. During under voltage lockout, the output stage can sink at least 10 mA at less than 1.2 V for V_{CC} over 5 V.

The difference between members of this family are shown in the table below.

PART NUMBER	UVLO ON	UVLO OFF	MAXIMUM DUTY CYCLE
UC1842A	16 V	10 V	<100%
UC1843A	8.5 V	7.9 V	<100%
UC1844A	16 V	10 V	<50%
UC1845A	8.5 V	7.9 V	<50%

ORDERING INFORMATION‡

T _A	PACKAGE‡		ORDERABLE PART NUMBER	TOP-SIDE MARKING
–55°C to 125°C	SOP – D	Tape and reel	UC1842AMDREP	1842AME
–55°C to 125°C	SOP – D	Tape and reel	UC1843AMDREP	1843AME
–55°C to 125°C	SOP – D	Tape and reel	UC1844AMDREP	1844AME
–55°C to 125°C	SOP – D	Tape and reel	UC1845AMDREP	1845AME

‡ Package drawings, standard packing quantities, thermal data, symbolization, and PCB design guidelines are available at www.ti.com/sc/package.



Please be aware that an important notice concerning availability, standard warranty, and use in critical applications of Texas Instruments semiconductor products and disclaimers thereto appears at the end of this data sheet.

PRODUCTION DATA information is current as of publication date. Products conform to specifications per the terms of Texas Instruments standard warranty. Production processing does not necessarily include testing of all parameters.

 **TEXAS
INSTRUMENTS**

POST OFFICE BOX 655303 • DALLAS, TEXAS 75265

Copyright © 2006, Texas Instruments Incorporated

UC1842A-EP, UC1843A-EP, UC1844A-EP, UC1845A-EP CURRENT-MODE PWM CONTROLLER

SGLS134C – SEPTEMBER 2002 – REVISED FEBRUARY 2006

block diagram

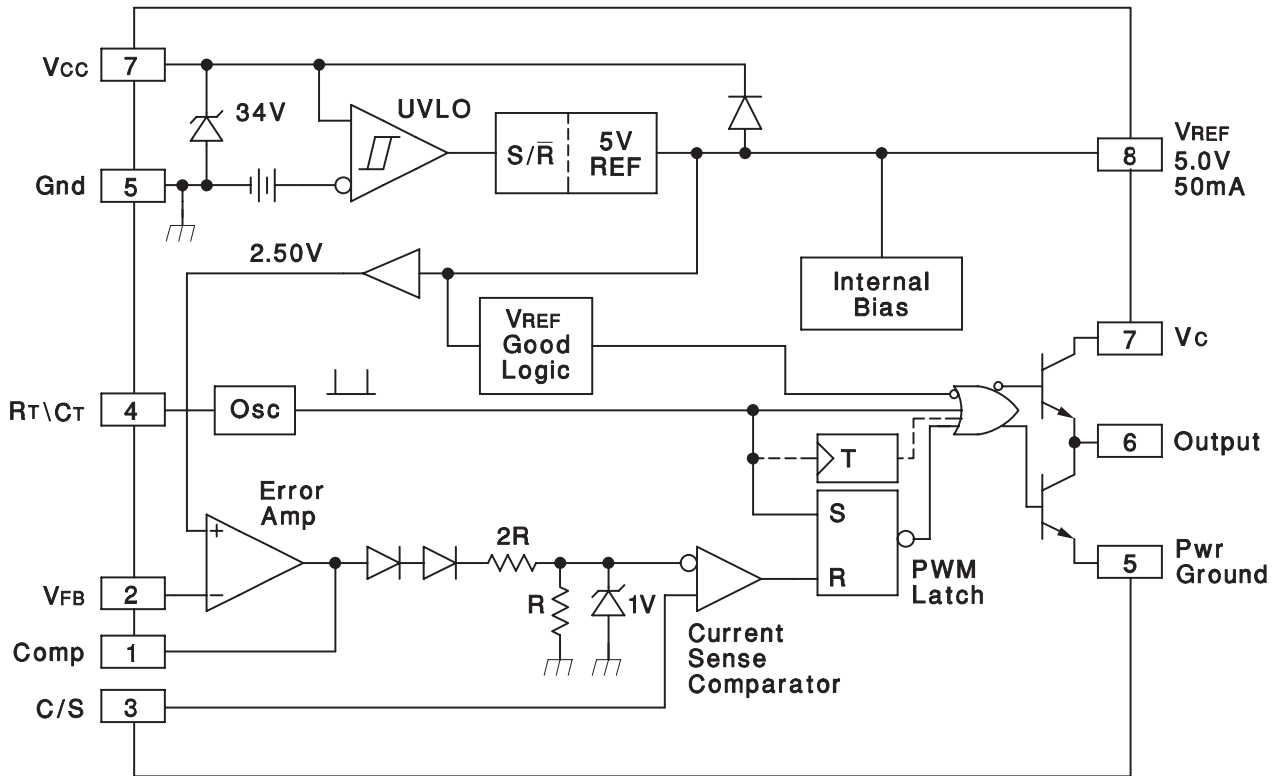

NOTES: 1. Toggle flip flop used only in 1844A and 1845A.

Ordering Information

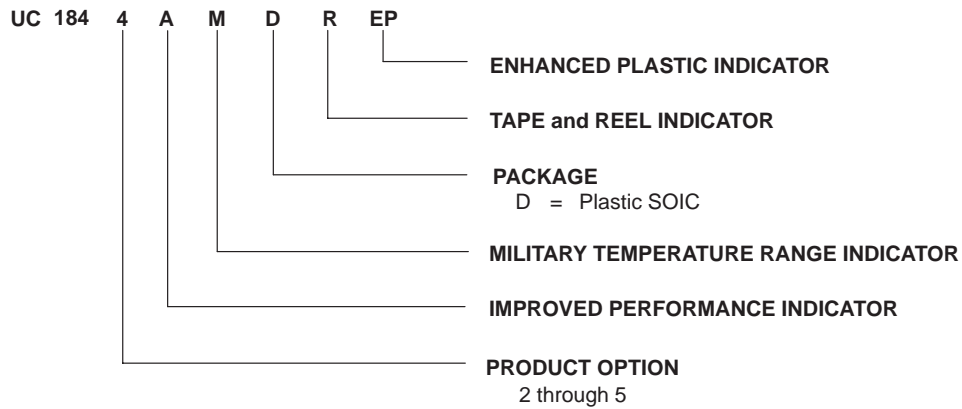

POST OFFICE BOX 655303 • DALLAS, TEXAS 75265

UC1842A-EP, UC1843A-EP, UC1844A-EP, UC1845A-EP CURRENT-MODE PWM CONTROLLER

SGLS134C – SEPTEMBER 2002 – REVISED FEBRUARY 2006

absolute maximum ratings over operating free-air temperature range (unless otherwise noted)^{†‡}

V_{CC} voltage (low impedance source)	30 V
V_{CC} voltage (I_{CC} mA)	self limiting
Output current, I_O	± 1 A
Output energy (capacitive load)	5 μ J
Analog Inputs (pins 2, 3)	-0.3 V to 6.3 V
Error Amp Output Sink current	10 mA
Power Dissipation at $T_A < 25^\circ\text{C}$	1 W
Package thermal impedance, θ_{JA} (see Note 1):	97°C/W
Storage temperature range, T_{stg}	-65°C to 150°C
Lead temperature soldering 1,6 mm (1/16 inch) from case for 10 seconds	260°C

[†] Stresses beyond those listed under “absolute maximum ratings” may cause permanent damage to the device. These are stress ratings only, and functional operation of the device at these or any other conditions beyond those indicated under “recommended operating conditions” is not implied. Exposure to absolute-maximum-rated conditions for extended periods may affect device reliability.

[‡] Unless otherwise indicated, voltages are reference to ground and currents are positive into and negative out of the specified terminals.

NOTE 1: Long term high-temperature storage and/or extended use at maximum recommended operating conditions may result in a reduction of overall device life. See http://www.ti.com/ep_quality for additional information on enhanced plastic packaging.

electrical characteristics, $T_A = -55^\circ\text{C}$ to 125°C for the UC184xAM-EP, $V_{CC} = 15$ V (see Note 1), $R_T = 10$ k Ω , $C_T = 3.3$ nF, and $T_A = T_J$ (unless otherwise stated)

PARAMETER	TEST CONDITIONS		MIN	TYP	MAX	UNITS
Reference Section						
Output voltage	$T_J = 25^\circ\text{C}$, $I_O = 1$ mA		4.95	5	5.05	V
Line regulation voltage	$V_{IN} = 12$ V to 25 V			6	20	mV
Load regulation voltage	$I_O = 1$ mA to 20 mA			6	25	mV
Temperature stability	See Notes NO TAG and NO TAG			0.2	0.4	mV/°C
Total output variation voltage	Line, Load, Temp.		4.9		5.1	V
Output noise voltage	f = 10 Hz to 10 kHz, See Note NO TAG	$T_J = 25^\circ\text{C}$		50		μ V
Long term stability	1000 hours, See Note 2	$T_A = 125^\circ\text{C}$		5	25	mV
Output short-circuit current			-30	-100	-180	mA
Oscillator Section						
Initial accuracy	See Note NO TAG	$T_J = 25^\circ\text{C}$	47	52	57	kHz
Voltage stability	$V_{CC} = 12$ V to 25 V			0.2%	1%	
Temperature stability	$T_A = \text{MIN}$ to MAX , See Note 2			5%		
Amplitude peak-to-peak	V pin 4, See Note 2			1.7		V
Discharge current	V pin 4 = 2 V, See Note 3	$T_J = 25^\circ\text{C}$	7.8	8.3	8.8	mA
		$T_J = \text{Full range}$	7.5		8.8	

- NOTES: 1. Adjust V_{CC} above the start threshold before setting at 15 V.
 2. Not production tested.
 3. This parameter is measured with $R_T = 10$ k Ω to V_{REF} . This contributes approximately 300 μ A of current to the measurement. The total current flowing into the R_T/C pin will be approximately 300 μ A higher than the measured value.



UC1842A-EP, UC1843A-EP, UC1844A-EP, UC1845A-EP CURRENT-MODE PWM CONTROLLER

SGLS134C – SEPTEMBER 2002 – REVISED FEBRUARY 2006

electrical characteristics, $T_A = -55^\circ\text{C}$ to 125°C for the UC184xAM-EP, $V_{CC} = 15\text{ V}$ (see Note 1), $R_T = 10\text{ k}\Omega$, $C_T = 3.3\text{ nF}$, and $T_A = T_J$ (unless otherwise stated)

PARAMETER	TEST CONDITIONS		MIN	TYP	MAX	UNITS
Error Amplifier Section						
Input voltage	COMP = 2.5 V		2.45	2.5	2.55	V
Input bias current				-0.3	-1	μA
Open loop voltage gain (A_{VOL})	$V_O = 2\text{ V}$ to 4 V		65	90		dB
Unity gain bandwidth	See Note 2	$T_J = 25^\circ\text{C}$	0.7	1		MHz
PSRR	$V_{CC} = 12\text{ V}$ to 25 V		60	70		dB
Output sink current	FB = 2.7 V, COMP = 1.1 V		2	6		mA
Output source current	FB = 2.3 V, COMP = 5 V		-0.5	-0.8		mA
V_{OUT} high	FB = 2.3 V, $R_L = 15\text{ k}\Omega$ to GND		5	6		V
V_{OUT} low	FB = 2.7 V, $R_L = 15\text{ k}\Omega$ to V_{REF}			0.7	1.1	V
Current Sense Section						
Gain	See Note 3 and Note 4		2.85	3	3.15	V/V
Maximum input signal	COMP = 5 V, See Note 3		0.9	1	1.1	V
PSRR	$V_{CC} = 12\text{ V}$ to 25 V , See Note 3			70		dB
Input bias current				-2	-10	μA
Delay to output	$I_{SENSE} = 0\text{ V}$ to 2 V , See Note 2			150	300	ns
Output Section (OUT)						
Low-level output voltage	$I_{OUT} = 20\text{ mA}$			0.1	0.4	V
	$I_{OUT} = 200\text{ mA}$			15	2.2	
High-level output voltage	$I_{OUT} = -20\text{ mA}$		13	13.5		V
	$I_{OUT} = -200\text{ mA}$		12	13.5		
Rise time	$C_L = 1\text{ nF}$, See Note 2	$T_J = 25^\circ\text{C}$		50	150	ns
Fall time	$C_L = 1\text{ nF}$, See Note 2	$T_J = 25^\circ\text{C}$		50	150	ns
UVLO saturation	$V_{CC} = 5\text{ V}$, $I_{OUT} = 10\text{ mA}$			0.7	1.2	V
Undervoltage Lockout Section						
Start threshold	UC1842A, UC1844A		15	16	17	V
	UC1843A, UC1845A		7.8	8.4	9	
Minimum operation voltage after turn on	UC1842A, UC1844A		9	10	11	V
	UC1843A, UC1845A		7	7.6	8.2	

- NOTES: 1. Adjust V_{CC} above the start threshold before setting at 15 V.
 2. Not production tested.
 3. Parameter measured at trip point of latch with V_{FB} at 0 V.
 4. Gain is defined by: $A = \frac{\Delta V_{COMP}}{\Delta V_{SENSE}}$; $0 \leq V_{SENSE} \leq 0.8\text{ V}$.



UC1842A-EP, UC1843A-EP, UC1844A-EP, UC1845A-EP CURRENT-MODE PWM CONTROLLER

SGLS134C – SEPTEMBER 2002 – REVISED FEBRUARY 2006

electrical characteristics, $T_A = -55^\circ\text{C}$ to 125°C for the UC184xAM-EP, $V_{CC} = 15\text{ V}$ (see Note 1), $R_T = 10\text{ k}\Omega$, $C_T = 3.3\text{ nF}$, and $T_A = T_J$ (unless otherwise stated)

PARAMETER	TEST CONDITIONS	MIN	TYP	MAX	UNITS
PWM Section					
Maximum duty cycle	UC1842A, UC1843A	94%	96%	100%	
	UC1844A, UC1845A	47%	48%	50%	
Minimum duty cycle				0%	
Total Standby Current					
Start-up current			0.3	0.5	mA
Operating supply current	FB = 0 V, SENSE = 0 V		11	17	mA
V_{CC} internal zener voltage	$I_{CC} = 25\text{ mA}$	30	34		V

NOTES: 1. Adjust V_{CC} above the start threshold before setting at 15 V.

PARAMETER MEASUREMENT INFORMATION

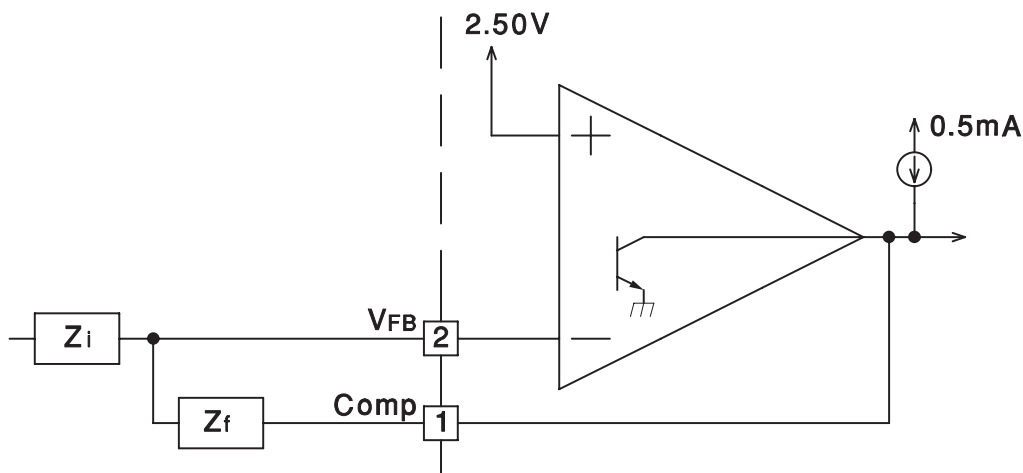

Error Amp can source and sink up to 0.5 mA and sink up to 2 mA.

Figure 1. Error Amp Configuration

UC1842A-EP, UC1843A-EP, UC1844A-EP, UC1845A-EP CURRENT-MODE PWM CONTROLLER

SGLS134C – SEPTEMBER 2002 – REVISED FEBRUARY 2006

PARAMETER MEASUREMENT INFORMATION

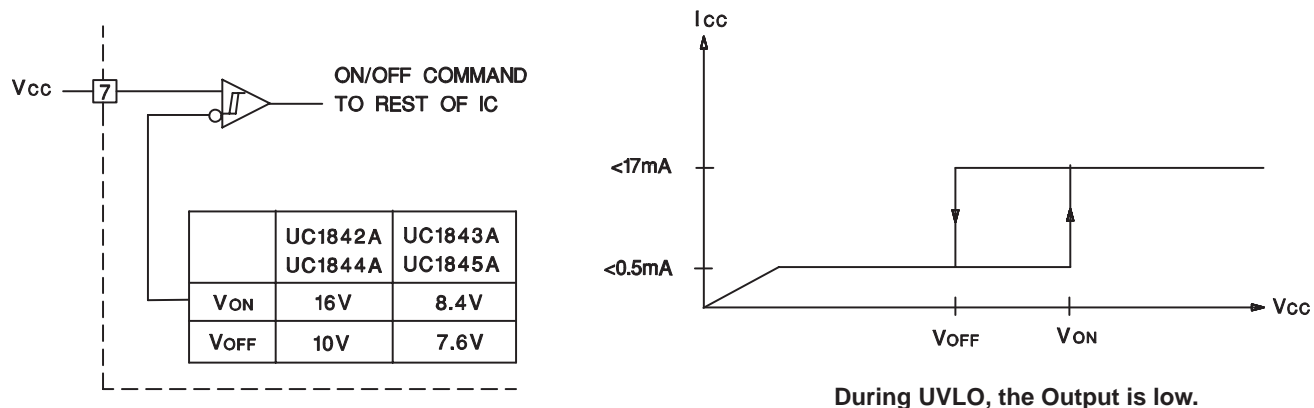
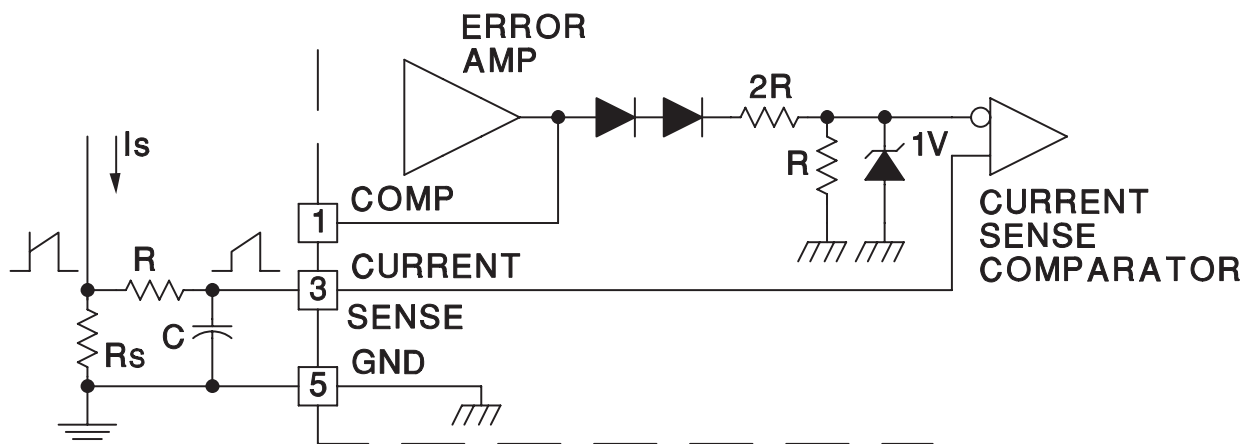

Figure 2. Under Voltage Lockout



Peak Current (I_s) is determined by the following formula:

$$I_{smax} = \frac{1V}{R_S}$$

A small RC filter may be required to suppress switch transients.

Figure 3. Current Sense Circuit

PARAMETER MEASUREMENT INFORMATION

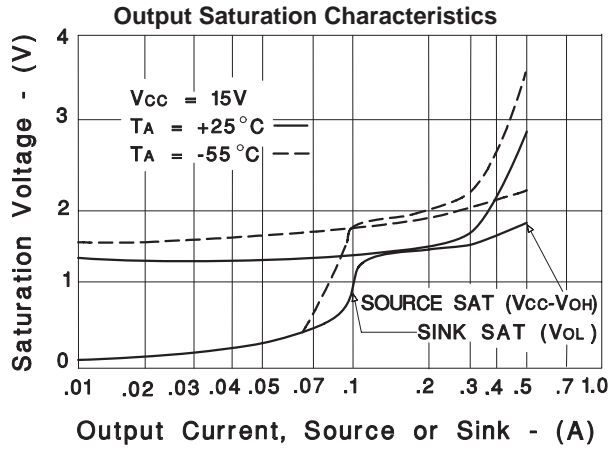

Figure 4

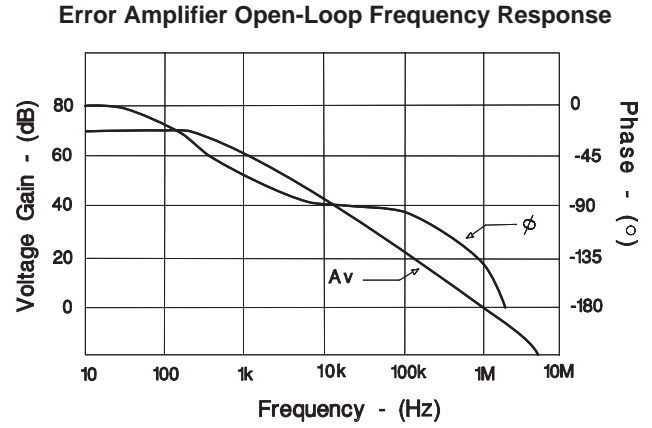

Figure 5

APPLICATION INFORMATION

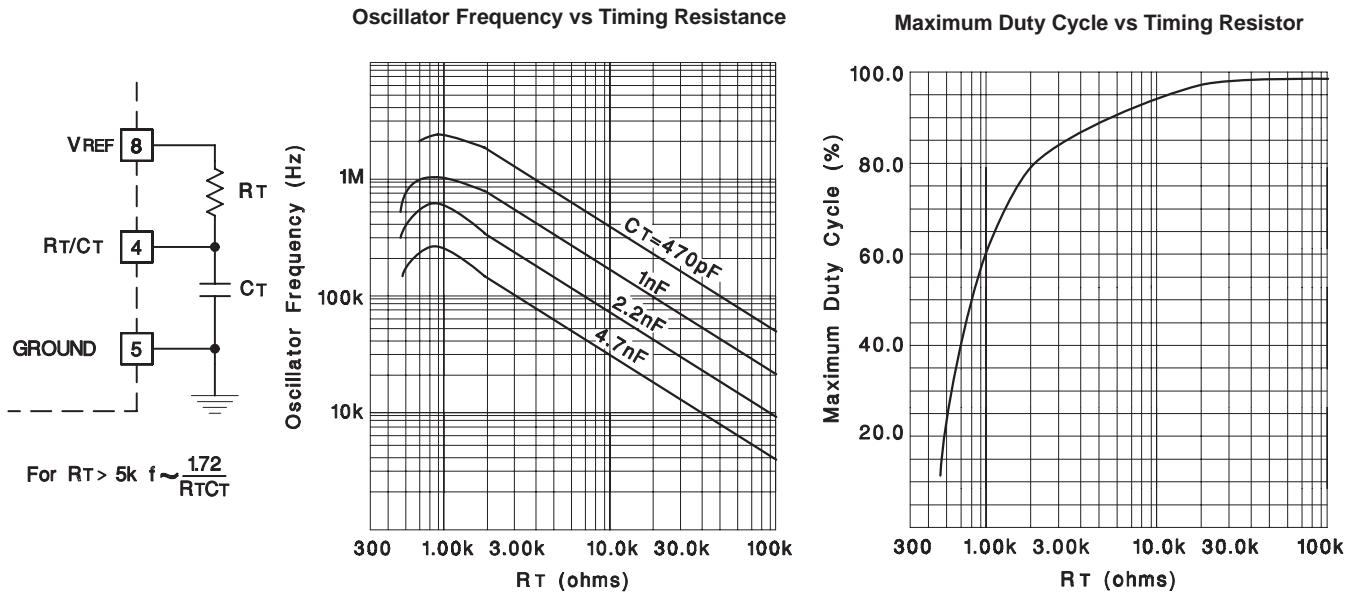
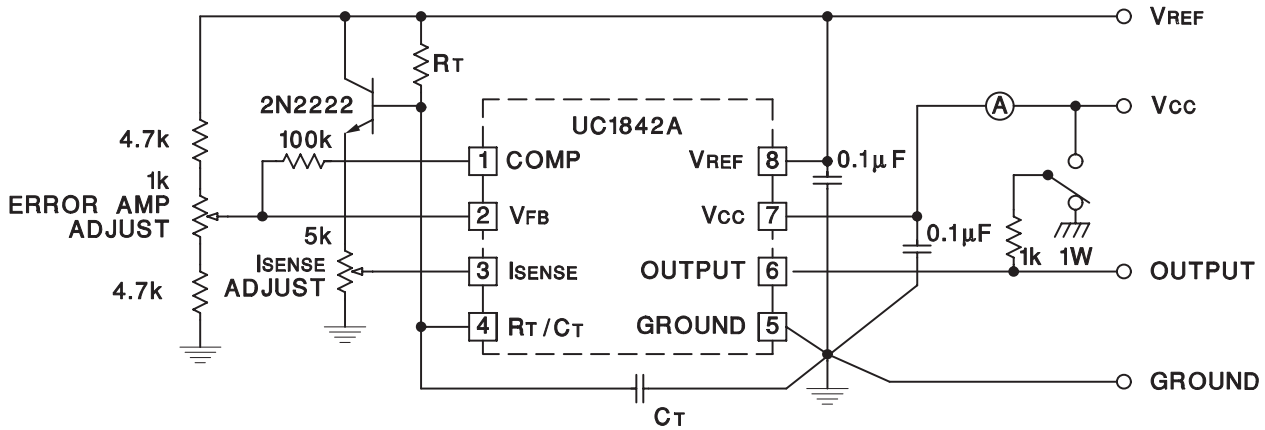

Figure 6. Oscillator

UC1842A-EP, UC1843A-EP, UC1844A-EP, UC1845A-EP CURRENT-MODE PWM CONTROLLER

SGLS134C – SEPTEMBER 2002 – REVISED FEBRUARY 2006

APPLICATION INFORMATION



High peak currents associated with capacitive loads necessitate careful grounding techniques. Timing and bypass capacitors should be connected close to pin 5 in a single point ground. The transistor and 5k potentiometer are used to sample the oscillator waveform and apply an adjustable ramp to pin 3.

Figure 7. Open-Loop Laboratory Text Fixture

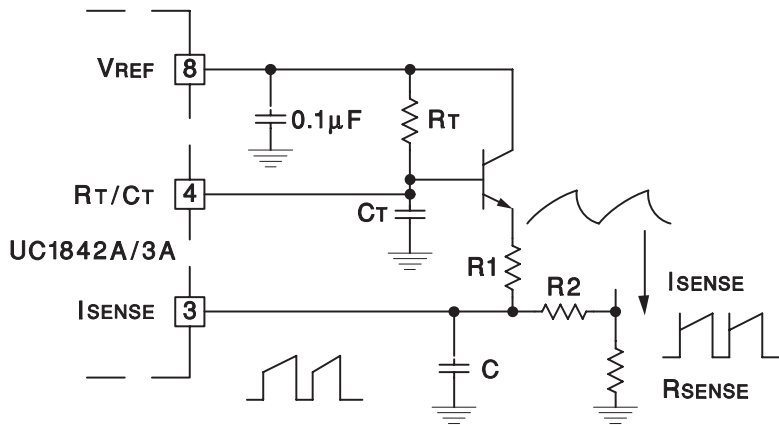

A fraction of the oscillator ramp can be resistively summed with the current sense signal to provide slope compensation for converters requiring duty cycles over 50%. Note that capacitor, C, forms a filter with R2 to suppress the leading edge switch spikes.

Figure 8. Slope Compression

APPLICATION INFORMATION

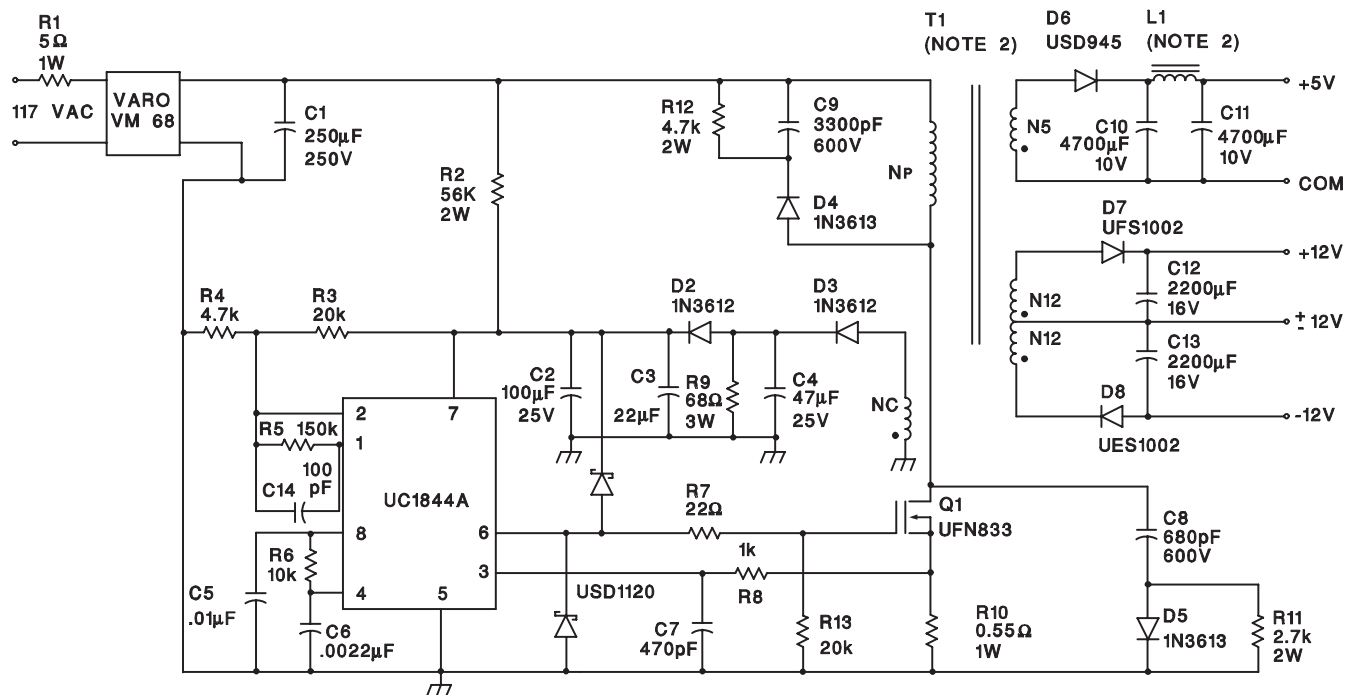

Power Supply Specifications

1. Input Voltage 95VAC to 130VAC (50 Hz/60 Hz)
2. Line Isolation 3750 V
3. Switching Frequency 40 kHz
4. Efficiency, Full Load 70%
5. Output Voltage:
 - A. +5V, $\pm 5\%$; 1A to 4A Load
 - B. +12V, $\pm 3\%$; 0.1A to 0.3A Load Ripple voltage: 100 mV P-P Max
 - C. -12V, $\pm 3\%$; 0.1A to 0.3A Load Ripple voltage: 100 mV P-P Max

Figure 9. Off-Line Flyback Regulator

PACKAGING INFORMATION

Orderable Device	Status ⁽¹⁾	Package Type	Package Drawing	Pins	Package Qty	Eco Plan ⁽²⁾	Lead/ Ball Finish	MSL Peak Temp ⁽³⁾	Samples (Requires Login)
UC1842AMDREP	ACTIVE	SOIC	D	8	2500	Green (RoHS & no Sb/Br)	CU NIPDAU	Level-1-260C-UNLIM	Add to cart
UC1843AMDREP	ACTIVE	SOIC	D	8	2500	Green (RoHS & no Sb/Br)	CU NIPDAU	Level-1-260C-UNLIM	Add to cart
UC1843AMDREPG4	ACTIVE	SOIC	D	8	2500	Green (RoHS & no Sb/Br)	CU NIPDAU	Level-1-260C-UNLIM	Add to cart
UC1844AMDREP	ACTIVE	SOIC	D	8	2500	Green (RoHS & no Sb/Br)	CU NIPDAU	Level-1-260C-UNLIM	Add to cart
UC1845AMDREP	ACTIVE	SOIC	D	8	2500	Green (RoHS & no Sb/Br)	CU NIPDAU	Level-1-260C-UNLIM	Add to cart
UC1845AMDREPG4	ACTIVE	SOIC	D	8	2500	Green (RoHS & no Sb/Br)	CU NIPDAU	Level-1-260C-UNLIM	Add to cart
V62/03625-01YE	ACTIVE	SOIC	D	8	2500	Green (RoHS & no Sb/Br)	CU NIPDAU	Level-1-260C-UNLIM	Add to cart
V62/03625-02YE	ACTIVE	SOIC	D	8	2500	Green (RoHS & no Sb/Br)	CU NIPDAU	Level-1-260C-UNLIM	Add to cart
V62/03625-03YE	ACTIVE	SOIC	D	8	2500	Green (RoHS & no Sb/Br)	CU NIPDAU	Level-1-260C-UNLIM	Add to cart
V62/03625-04YE	ACTIVE	SOIC	D	8	2500	Green (RoHS & no Sb/Br)	CU NIPDAU	Level-1-260C-UNLIM	Add to cart

⁽¹⁾ The marketing status values are defined as follows:

ACTIVE: Product device recommended for new designs.

LIFEBUY: TI has announced that the device will be discontinued, and a lifetime-buy period is in effect.

NRND: Not recommended for new designs. Device is in production to support existing customers, but TI does not recommend using this part in a new design.

PREVIEW: Device has been announced but is not in production. Samples may or may not be available.

OBSELETE: TI has discontinued the production of the device.

⁽²⁾ Eco Plan - The planned eco-friendly classification: Pb-Free (RoHS), Pb-Free (RoHS Exempt), or Green (RoHS & no Sb/Br) - please check <http://www.ti.com/productcontent> for the latest availability information and additional product content details.

TBD: The Pb-Free/Green conversion plan has not been defined.

Pb-Free (RoHS): TI's terms "Lead-Free" or "Pb-Free" mean semiconductor products that are compatible with the current RoHS requirements for all 6 substances, including the requirement that lead not exceed 0.1% by weight in homogeneous materials. Where designed to be soldered at high temperatures, TI Pb-Free products are suitable for use in specified lead-free processes.

Pb-Free (RoHS Exempt): This component has a RoHS exemption for either 1) lead-based flip-chip solder bumps used between the die and package, or 2) lead-based die adhesive used between the die and leadframe. The component is otherwise considered Pb-Free (RoHS compatible) as defined above.

Green (RoHS & no Sb/Br): TI defines "Green" to mean Pb-Free (RoHS compatible), and free of Bromine (Br) and Antimony (Sb) based flame retardants (Br or Sb do not exceed 0.1% by weight in homogeneous material)

⁽³⁾ MSL, Peak Temp. -- The Moisture Sensitivity Level rating according to the JEDEC industry standard classifications, and peak solder temperature.

Important Information and Disclaimer: The information provided on this page represents TI's knowledge and belief as of the date that it is provided. TI bases its knowledge and belief on information provided by third parties, and makes no representation or warranty as to the accuracy of such information. Efforts are underway to better integrate information from third parties. TI has taken and continues to take reasonable steps to provide representative and accurate information but may not have conducted destructive testing or chemical analysis on incoming materials and chemicals. TI and TI suppliers consider certain information to be proprietary, and thus CAS numbers and other limited information may not be available for release.

In no event shall TI's liability arising out of such information exceed the total purchase price of the TI part(s) at issue in this document sold by TI to Customer on an annual basis.

OTHER QUALIFIED VERSIONS OF UC1842A-EP, UC1843A-EP, UC1844A-EP, UC1845A-EP :

- Catalog: [UC1842A](#), [UC1843A](#), [UC1844A](#), [UC1845A](#)
- Space: [UC1842A-SP](#), [UC1843A-SP](#), [UC1844A-SP](#), [UC1845A-SP](#)

NOTE: Qualified Version Definitions:

- Catalog - TI's standard catalog product
- Space - Radiation tolerant, ceramic packaging and qualified for use in Space-based application

TAPE AND REEL INFORMATION

QUADRANT ASSIGNMENTS FOR PIN 1 ORIENTATION IN TAPE

*All dimensions are nominal

Device	Package Type	Package Drawing	Pins	SPQ	Reel Diameter (mm)	Reel Width W1 (mm)	A0 (mm)	B0 (mm)	K0 (mm)	P1 (mm)	W (mm)	Pin1 Quadrant
UC1842AMDREP	SOIC	D	8	2500	330.0	12.4	6.4	5.2	2.1	4.0	12.0	Q1
UC1843AMDREP	SOIC	D	8	2500	330.0	12.4	6.4	5.2	2.1	4.0	12.0	Q1
UC1844AMDREP	SOIC	D	8	2500	330.0	12.4	6.4	5.2	2.1	4.0	12.0	Q1
UC1845AMDREP	SOIC	D	8	2500	330.0	12.4	6.4	5.2	2.1	4.0	12.0	Q1

TAPE AND REEL BOX DIMENSIONS



*All dimensions are nominal

Device	Package Type	Package Drawing	Pins	SPQ	Length (mm)	Width (mm)	Height (mm)
UC1842AMDREP	SOIC	D	8	2500	367.0	367.0	35.0
UC1843AMDREP	SOIC	D	8	2500	367.0	367.0	35.0
UC1844AMDREP	SOIC	D	8	2500	367.0	367.0	35.0
UC1845AMDREP	SOIC	D	8	2500	367.0	367.0	35.0

D (R-PDSO-G8)

PLASTIC SMALL OUTLINE

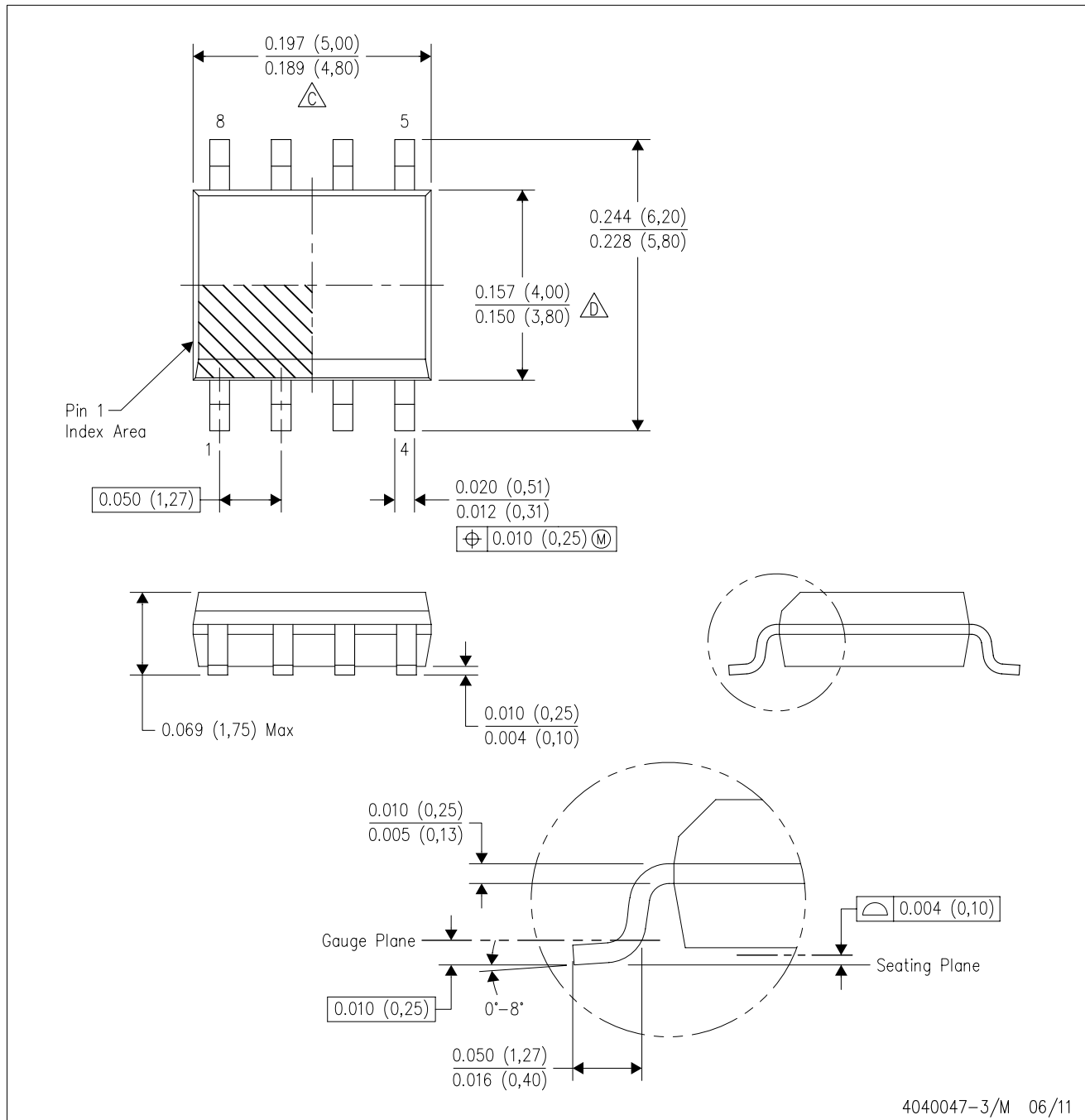

- NOTES:
- A. All linear dimensions are in inches (millimeters).
 - B. This drawing is subject to change without notice.
 - $\triangle C$ Body length does not include mold flash, protrusions, or gate burrs. Mold flash, protrusions, or gate burrs shall not exceed 0.006 (0,15) each side.
 - $\triangle D$ Body width does not include interlead flash. Interlead flash shall not exceed 0.017 (0,43) each side.
 - E. Reference JEDEC MS-012 variation AA.

IMPORTANT NOTICE

Texas Instruments Incorporated and its subsidiaries (TI) reserve the right to make corrections, modifications, enhancements, improvements, and other changes to its products and services at any time and to discontinue any product or service without notice. Customers should obtain the latest relevant information before placing orders and should verify that such information is current and complete. All products are sold subject to TI's terms and conditions of sale supplied at the time of order acknowledgment.

TI warrants performance of its hardware products to the specifications applicable at the time of sale in accordance with TI's standard warranty. Testing and other quality control techniques are used to the extent TI deems necessary to support this warranty. Except where mandated by government requirements, testing of all parameters of each product is not necessarily performed.

TI assumes no liability for applications assistance or customer product design. Customers are responsible for their products and applications using TI components. To minimize the risks associated with customer products and applications, customers should provide adequate design and operating safeguards.

TI does not warrant or represent that any license, either express or implied, is granted under any TI patent right, copyright, mask work right, or other TI intellectual property right relating to any combination, machine, or process in which TI products or services are used. Information published by TI regarding third-party products or services does not constitute a license from TI to use such products or services or a warranty or endorsement thereof. Use of such information may require a license from a third party under the patents or other intellectual property of the third party, or a license from TI under the patents or other intellectual property of TI.

Reproduction of TI information in TI data books or data sheets is permissible only if reproduction is without alteration and is accompanied by all associated warranties, conditions, limitations, and notices. Reproduction of this information with alteration is an unfair and deceptive business practice. TI is not responsible or liable for such altered documentation. Information of third parties may be subject to additional restrictions.

Resale of TI products or services with statements different from or beyond the parameters stated by TI for that product or service voids all express and any implied warranties for the associated TI product or service and is an unfair and deceptive business practice. TI is not responsible or liable for any such statements.

TI products are not authorized for use in safety-critical applications (such as life support) where a failure of the TI product would reasonably be expected to cause severe personal injury or death, unless officers of the parties have executed an agreement specifically governing such use. Buyers represent that they have all necessary expertise in the safety and regulatory ramifications of their applications, and acknowledge and agree that they are solely responsible for all legal, regulatory and safety-related requirements concerning their products and any use of TI products in such safety-critical applications, notwithstanding any applications-related information or support that may be provided by TI. Further, Buyers must fully indemnify TI and its representatives against any damages arising out of the use of TI products in such safety-critical applications.

TI products are neither designed nor intended for use in military/aerospace applications or environments unless the TI products are specifically designated by TI as military-grade or "enhanced plastic." Only products designated by TI as military-grade meet military specifications. Buyers acknowledge and agree that any such use of TI products which TI has not designated as military-grade is solely at the Buyer's risk, and that they are solely responsible for compliance with all legal and regulatory requirements in connection with such use.

TI products are neither designed nor intended for use in automotive applications or environments unless the specific TI products are designated by TI as compliant with ISO/TS 16949 requirements. Buyers acknowledge and agree that, if they use any non-designated products in automotive applications, TI will not be responsible for any failure to meet such requirements.

Following are URLs where you can obtain information on other Texas Instruments products and application solutions:

Products

Audio	www.ti.com/audio
Amplifiers	amplifier.ti.com
Data Converters	dataconverter.ti.com
DLP® Products	www.dlp.com
DSP	dsp.ti.com
Clocks and Timers	www.ti.com/clocks
Interface	interface.ti.com
Logic	logic.ti.com
Power Mgmt	power.ti.com
Microcontrollers	microcontroller.ti.com
RFID	www.ti-rfid.com
OMAP Mobile Processors	www.ti.com/omap
Wireless Connectivity	www.ti.com/wirelessconnectivity

Applications

Automotive and Transportation	www.ti.com/automotive
Communications and Telecom	www.ti.com/communications
Computers and Peripherals	www.ti.com/computers
Consumer Electronics	www.ti.com/consumer-apps
Energy and Lighting	www.ti.com/energy
Industrial	www.ti.com/industrial
Medical	www.ti.com/medical
Security	www.ti.com/security
Space, Avionics and Defense	www.ti.com/space-avionics-defense
Video and Imaging	www.ti.com/video

TI E2E Community Home Page

e2e.ti.com

Mailing Address: Texas Instruments, Post Office Box 655303, Dallas, Texas 75265
Copyright © 2012, Texas Instruments Incorporated