

μA7800 SERIES POSITIVE-VOLTAGE REGULATORS

SLVS056K – MAY 1976 – REVISED APRIL 2005

- 3-Terminal Regulators
- Output Current up to 1.5 A
- Internal Thermal-Overload Protection
- High Power-Dissipation Capability
- Internal Short-Circuit Current Limiting
- Output Transistor Safe-Area Compensation

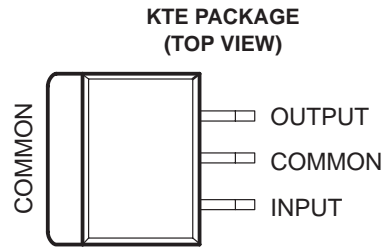
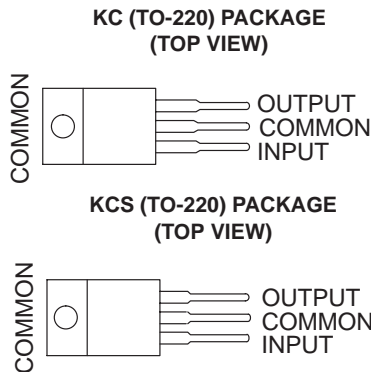

description/ordering information

This series of fixed-voltage integrated-circuit voltage regulators is designed for a wide range of applications. These applications include on-card regulation for elimination of noise and distribution problems associated with single-point regulation. Each of these regulators can deliver up to 1.5 A of output current. The internal current-limiting and thermal-shutdown features of these regulators essentially make them immune to overload. In addition to use as fixed-voltage regulators, these devices can be used with external components to obtain adjustable output voltages and currents, and also can be used as the power-pass element in precision regulators.

ORDERING INFORMATION

T _J	V _{O(NOM)} (V)	PACKAGE†		ORDERABLE PART NUMBER	TOP-SIDE MARKING
0°C to 125°C	5	PowerFLEX™ (KTE)	Reel of 2000	μA7805CKTER	μA7805C
		TO-220 (KC)	Tube of 50	μA7805CKC	μA7805C
		TO-220, short shoulder (KCS)	Tube of 20	μA7805CKCS	
	8	PowerFLEX (KTE)	Reel of 2000	μA7808CKTER	μA7808C
		TO-220 (KC)	Tube of 50	μA7808CKC	μA7808C
		TO-220, short shoulder (KCS)	Tube of 20	μA7808CKCS	
	10	PowerFLEX (KTE)	Reel of 2000	μA7810CKTER	μA7810C
		TO-220 (KC)	Tube of 50	μA7810CKC	μA7810C
	12	PowerFLEX (KTE)	Reel of 2000	μA7812CKTER	μA7812C
		TO-220 (KC)	Tube of 50	μA7812CKC	μA7812C
		TO-220, short shoulder (KCS)	Tube of 20	μA7812CKCS	
	15	PowerFLEX (KTE)	Reel of 2000	μA7815CKTER	μA7815C
		TO-220 (KC)	Tube of 50	μA7815CKC	μA7815C
		TO-220, short shoulder (KCS)	Tube of 20	μA7815CKCS	
	24	PowerFLEX (KTE)	Reel of 2000	μA7824CKTER	μA7824C
		TO-220 (KC)	Tube of 50	μA7824CKC	μA7824C

† Package drawings, standard packing quantities, thermal data, symbolization, and PCB design guidelines are available at www.ti.com/sc/package.



Please be aware that an important notice concerning availability, standard warranty, and use in critical applications of Texas Instruments semiconductor products and disclaimers thereto appears at the end of this data sheet.

PowerFLEX is a trademark of Texas Instruments.

PRODUCTION DATA information is current as of publication date. Products conform to specifications per the terms of Texas Instruments standard warranty. Production processing does not necessarily include testing of all parameters.



POST OFFICE BOX 655303 • DALLAS, TEXAS 75265

Copyright © 2005, Texas Instruments Incorporated

μA7800 SERIES POSITIVE-VOLTAGE REGULATORS

SLVS056K – MAY 1976 – REVISED APRIL 2005

schematic

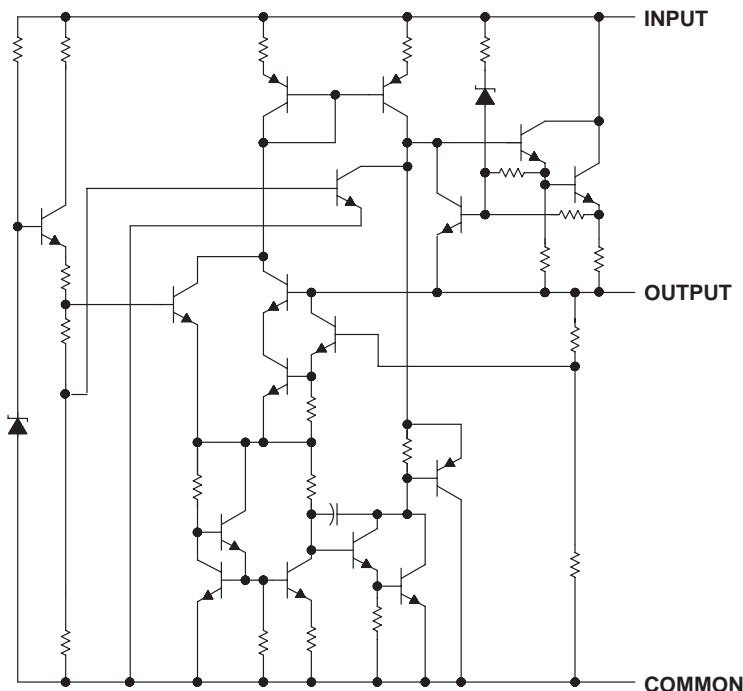

absolute maximum ratings over virtual junction temperature range (unless otherwise noted)†

Input voltage, V_I : μA7824C	40 V
All others	35 V
Operating virtual junction temperature, T_J	150°C
Lead temperature 1,6 mm (1/16 inch) from case for 10 seconds	260°C
Storage temperature range, T_{stg}	-65°C to 150°C

† Stresses beyond those listed under “absolute maximum ratings” may cause permanent damage to the device. These are stress ratings only, and functional operation of the device at these or any other conditions beyond those indicated under “recommended operating conditions” is not implied. Exposure to absolute-maximum-rated conditions for extended periods may affect device reliability.

package thermal data (see Note 1)

PACKAGE	BOARD	θ_{JC}	θ_{JA}	θ_{JP}^\ddagger
PowerFLEX (KTE)	High K, JESD 51-5	3°C/W	23°C/W	
TO-220 (KC/KCS)	High K, JESD 51-5	17°C/W	19°C/W	3°C/W

NOTE 1: Maximum power dissipation is a function of $T_J(\max)$, θ_{JA} , and T_A . The maximum allowable power dissipation at any allowable ambient temperature is $P_D = (T_J(\max) - T_A)/\theta_{JA}$. Operating at the absolute maximum T_J of 150°C can affect reliability.

‡ For packages with exposed thermal pads, such as QFN, PowerPAD, or PowerFLEX, θ_{JP} is defined as the thermal resistance between the die junction and the bottom of the exposed pad.



POST OFFICE BOX 655303 • DALLAS, TEXAS 75265

μA7800 SERIES POSITIVE-VOLTAGE REGULATORS

SLVS056K – MAY 1976 – REVISED APRIL 2005

recommended operating conditions

		MIN	MAX	UNIT
V_I Input voltage	μA7805C	7	25	V
	μA7808C	10.5	25	
	μA7810C	12.5	28	
	μA7812C	14.5	30	
	μA7815C	17.5	30	
	μA7824C	27	38	
I_O Output current		1.5		A
T_J Operating virtual junction temperature	μA7800C series	0	125	°C

electrical characteristics at specified virtual junction temperature, $V_I = 10\text{ V}$, $I_O = 500\text{ mA}$ (unless otherwise noted)

PARAMETER	TEST CONDITIONS	T_J †	μA7805C			UNIT	
			MIN	TYP	MAX		
Output voltage	$I_O = 5\text{ mA to }1\text{ A}$, $P_D \leq 15\text{ W}$	25°C	4.8	5	5.2	V	
		0°C to 125°C	4.75		5.25		
Input voltage regulation	$V_I = 7\text{ V to }25\text{ V}$	25°C		3	100	mV	
	$V_I = 8\text{ V to }12\text{ V}$			1	50		
Ripple rejection	$V_I = 8\text{ V to }18\text{ V}$, $f = 120\text{ Hz}$	0°C to 125°C	62	78		dB	
Output voltage regulation	$I_O = 5\text{ mA to }1.5\text{ A}$	25°C		15	100	mV	
	$I_O = 250\text{ mA to }750\text{ mA}$			5	50		
Output resistance	$f = 1\text{ kHz}$	0°C to 125°C	0.017			Ω	
Temperature coefficient of output voltage	$I_O = 5\text{ mA}$	0°C to 125°C	-1.1			mV/°C	
Output noise voltage	$f = 10\text{ Hz to }100\text{ kHz}$	25°C	40			μV	
Dropout voltage	$I_O = 1\text{ A}$	25°C	2			V	
Bias current		25°C	4.2			8	mA
Bias current change	$V_I = 7\text{ V to }25\text{ V}$	0°C to 125°C				1.3	mA
	$I_O = 5\text{ mA to }1\text{ A}$					0.5	
Short-circuit output current		25°C	750			mA	
Peak output current		25°C	2.2			A	

† Pulse-testing techniques maintain the junction temperature as close to the ambient temperature as possible. Thermal effects must be taken into account separately. All characteristics are measured with a 0.33-μF capacitor across the input and a 0.1-μF capacitor across the output.

μA7800 SERIES POSITIVE-VOLTAGE REGULATORS

SLVS056K – MAY 1976 – REVISED APRIL 2005

electrical characteristics at specified virtual junction temperature, $V_I = 14\text{ V}$, $I_O = 500\text{ mA}$ (unless otherwise noted)

PARAMETER	TEST CONDITIONS	T_J †	μA7808C			UNIT
			MIN	TYP	MAX	
Output voltage	$I_O = 5\text{ mA to }1\text{ A}$, $P_D \leq 15\text{ W}$	25°C	7.7	8	8.3	V
		0°C to 125°C	7.6		8.4	
Input voltage regulation	$V_I = 10.5\text{ V to }25\text{ V}$	25°C		6	160	mV
	$V_I = 11\text{ V to }17\text{ V}$			2	80	
Ripple rejection	$V_I = 11.5\text{ V to }21.5\text{ V}$, $f = 120\text{ Hz}$	0°C to 125°C	55	72		dB
Output voltage regulation	$I_O = 5\text{ mA to }1.5\text{ A}$	25°C		12	160	mV
	$I_O = 250\text{ mA to }750\text{ mA}$			4	80	
Output resistance	$f = 1\text{ kHz}$	0°C to 125°C	0.016			Ω
Temperature coefficient of output voltage	$I_O = 5\text{ mA}$	0°C to 125°C	-0.8			mV/°C
Output noise voltage	$f = 10\text{ Hz to }100\text{ kHz}$	25°C	52			μV
Dropout voltage	$I_O = 1\text{ A}$	25°C	2			V
Bias current		25°C	4.3		8	mA
Bias current change	$V_I = 10.5\text{ V to }25\text{ V}$	0°C to 125°C			1	mA
	$I_O = 5\text{ mA to }1\text{ A}$				0.5	
Short-circuit output current		25°C	450			mA
Peak output current		25°C	2.2			A

† Pulse-testing techniques maintain the junction temperature as close to the ambient temperature as possible. Thermal effects must be taken into account separately. All characteristics are measured with a 0.33-μF capacitor across the input and a 0.1-μF capacitor across the output.

electrical characteristics at specified virtual junction temperature, $V_I = 17\text{ V}$, $I_O = 500\text{ mA}$ (unless otherwise noted)

PARAMETER	TEST CONDITIONS	T_J †	μA7810C			UNIT
			MIN	TYP	MAX	
Output voltage	$I_O = 5\text{ mA to }1\text{ A}$, $P_D \leq 15\text{ W}$	25°C	9.6	10	10.4	V
		0°C to 125°C	9.5	10	10.5	
Input voltage regulation	$V_I = 12.5\text{ V to }28\text{ V}$	25°C		7	200	mV
	$V_I = 14\text{ V to }20\text{ V}$			2	100	
Ripple rejection	$V_I = 13\text{ V to }23\text{ V}$, $f = 120\text{ Hz}$	0°C to 125°C	55	71		dB
Output voltage regulation	$I_O = 5\text{ mA to }1.5\text{ A}$	25°C		12	200	mV
	$I_O = 250\text{ mA to }750\text{ mA}$			4	100	
Output resistance	$f = 1\text{ kHz}$	0°C to 125°C	0.018			Ω
Temperature coefficient of output voltage	$I_O = 5\text{ mA}$	0°C to 125°C	-1			mV/°C
Output noise voltage	$f = 10\text{ Hz to }100\text{ kHz}$	25°C	70			μV
Dropout voltage	$I_O = 1\text{ A}$	25°C	2			V
Bias current		25°C	4.3		8	mA
Bias current change	$V_I = 12.5\text{ V to }28\text{ V}$	0°C to 125°C			1	mA
	$I_O = 5\text{ mA to }1\text{ A}$				0.5	
Short-circuit output current		25°C	400			mA
Peak output current		25°C	2.2			A

† Pulse-testing techniques maintain the junction temperature as close to the ambient temperature as possible. Thermal effects must be taken into account separately. All characteristics are measured with a 0.33-μF capacitor across the input and a 0.1-μF capacitor across the output.



μA7800 SERIES POSITIVE-VOLTAGE REGULATORS

SLVS056K – MAY 1976 – REVISED APRIL 2005

electrical characteristics at specified virtual junction temperature, $V_I = 19\text{ V}$, $I_O = 500\text{ mA}$ (unless otherwise noted)

PARAMETER	TEST CONDITIONS	T_J †	μA7812C			UNIT	
			MIN	TYP	MAX		
Output voltage	$I_O = 5\text{ mA to }1\text{ A}$, $P_D \leq 15\text{ W}$	25°C	11.5	12	12.5	V	
		0°C to 125°C	11.4		12.6		
Input voltage regulation	$V_I = 14.5\text{ V to }30\text{ V}$	25°C		10	240	mV	
	$V_I = 16\text{ V to }22\text{ V}$			3	120		
Ripple rejection	$V_I = 15\text{ V to }25\text{ V}$, $f = 120\text{ Hz}$	0°C to 125°C	55	71		dB	
Output voltage regulation	$I_O = 5\text{ mA to }1.5\text{ A}$	25°C		12	240	mV	
	$I_O = 250\text{ mA to }750\text{ mA}$			4	120		
Output resistance	$f = 1\text{ kHz}$	0°C to 125°C	0.018			Ω	
Temperature coefficient of output voltage	$I_O = 5\text{ mA}$	0°C to 125°C	-1			mV/°C	
Output noise voltage	$f = 10\text{ Hz to }100\text{ kHz}$	25°C	75			μV	
Dropout voltage	$I_O = 1\text{ A}$	25°C	2			V	
Bias current		25°C	4.3			8	mA
Bias current change	$V_I = 14.5\text{ V to }30\text{ V}$	0°C to 125°C				1	mA
	$I_O = 5\text{ mA to }1\text{ A}$					0.5	
Short-circuit output current		25°C	350			mA	
Peak output current		25°C	2.2			A	

† Pulse-testing techniques maintain the junction temperature as close to the ambient temperature as possible. Thermal effects must be taken into account separately. All characteristics are measured with a 0.33-μF capacitor across the input and a 0.1-μF capacitor across the output.

electrical characteristics at specified virtual junction temperature, $V_I = 23\text{ V}$, $I_O = 500\text{ mA}$ (unless otherwise noted)

PARAMETER	TEST CONDITIONS	T_J †	μA7815C			UNIT	
			MIN	TYP	MAX		
Output voltage	$I_O = 5\text{ mA to }1\text{ A}$, $P_D \leq 15\text{ W}$	25°C	14.4	15	15.6	V	
		0°C to 125°C	14.25		15.75		
Input voltage regulation	$V_I = 17.5\text{ V to }30\text{ V}$	25°C		11	300	mV	
	$V_I = 20\text{ V to }26\text{ V}$			3	150		
Ripple rejection	$V_I = 18.5\text{ V to }28.5\text{ V}$, $f = 120\text{ Hz}$	0°C to 125°C	54	70		dB	
Output voltage regulation	$I_O = 5\text{ mA to }1.5\text{ A}$	25°C		12	300	mV	
	$I_O = 250\text{ mA to }750\text{ mA}$			4	150		
Output resistance	$f = 1\text{ kHz}$	0°C to 125°C	0.019			Ω	
Temperature coefficient of output voltage	$I_O = 5\text{ mA}$	0°C to 125°C	-1			mV/°C	
Output noise voltage	$f = 10\text{ Hz to }100\text{ kHz}$	25°C	90			μV	
Dropout voltage	$I_O = 1\text{ A}$	25°C	2			V	
Bias current		25°C	4.4			8	mA
Bias current change	$V_I = 17.5\text{ V to }30\text{ V}$	0°C to 125°C				1	mA
	$I_O = 5\text{ mA to }1\text{ A}$					0.5	
Short-circuit output current		25°C	230			mA	
Peak output current		25°C	2.1			A	

† Pulse-testing techniques maintain the junction temperature as close to the ambient temperature as possible. Thermal effects must be taken into account separately. All characteristics are measured with a 0.33-μF capacitor across the input and a 0.1-μF capacitor across the output.



μA7800 SERIES POSITIVE-VOLTAGE REGULATORS

SLVS056K – MAY 1976 – REVISED APRIL 2005

electrical characteristics at specified virtual junction temperature, $V_I = 33\text{ V}$, $I_O = 500\text{ mA}$ (unless otherwise noted)

PARAMETER	TEST CONDITIONS	T_J †	μA7824C			UNIT
			MIN	TYP	MAX	
Output voltage	$I_O = 5\text{ mA to }1\text{ A}$, $P_D \leq 15\text{ W}$	$V_I = 27\text{ V to }38\text{ V}$, 25°C	23	24	25	V
		$0^\circ\text{C to }125^\circ\text{C}$	22.8		25.2	
Input voltage regulation	$V_I = 27\text{ V to }38\text{ V}$	25°C		18	480	mV
	$V_I = 30\text{ V to }36\text{ V}$			6	240	
Ripple rejection	$V_I = 28\text{ V to }38\text{ V}$, $f = 120\text{ Hz}$	$0^\circ\text{C to }125^\circ\text{C}$	50	66		dB
Output voltage regulation	$I_O = 5\text{ mA to }1.5\text{ A}$	25°C		12	480	mV
	$I_O = 250\text{ mA to }750\text{ mA}$			4	240	
Output resistance	$f = 1\text{ kHz}$	$0^\circ\text{C to }125^\circ\text{C}$	0.028			Ω
Temperature coefficient of output voltage	$I_O = 5\text{ mA}$	$0^\circ\text{C to }125^\circ\text{C}$	-1.5			mV/°C
Output noise voltage	$f = 10\text{ Hz to }100\text{ kHz}$	25°C	170			μV
Dropout voltage	$I_O = 1\text{ A}$	25°C	2			V
Bias current		25°C	4.6	8		mA
Bias current change	$V_I = 27\text{ V to }38\text{ V}$	$0^\circ\text{C to }125^\circ\text{C}$			1	mA
	$I_O = 5\text{ mA to }1\text{ A}$				0.5	
Short-circuit output current		25°C	150			mA
Peak output current		25°C	2.1			A

† Pulse-testing techniques maintain the junction temperature as close to the ambient temperature as possible. Thermal effects must be taken into account separately. All characteristics are measured with a 0.33- μF capacitor across the input and a 0.1- μF capacitor across the output.



APPLICATION INFORMATION

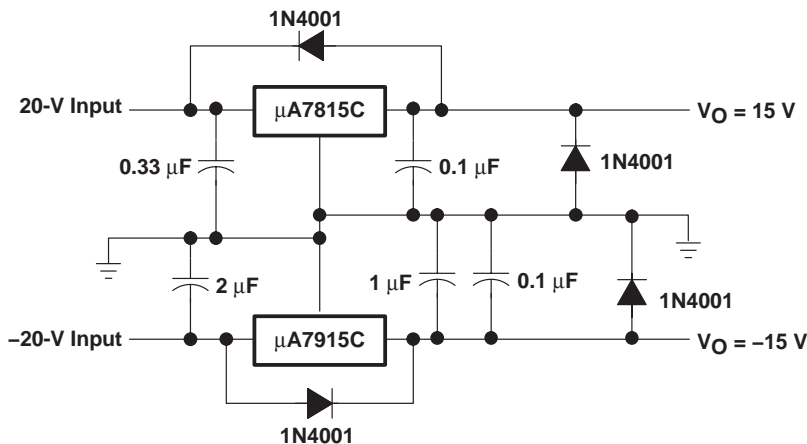

Figure 5. Regulated Dual Supply

operation with a load common to a voltage of opposite polarity

In many cases, a regulator powers a load that is not connected to ground but, instead, is connected to a voltage source of opposite polarity (e.g., operational amplifiers, level-shifting circuits, etc.). In these cases, a clamp diode should be connected to the regulator output as shown in Figure 6. This protects the regulator from output polarity reversals during startup and short-circuit operation.

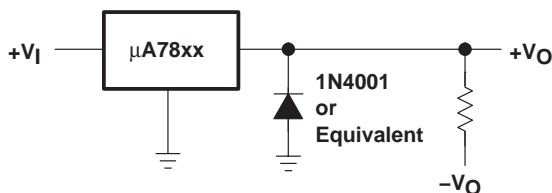

Figure 6. Output Polarity-Reversal-Protection Circuit

reverse-bias protection

Occasionally, the input voltage to the regulator can collapse faster than the output voltage. This can occur, for example, when the input supply is crowbarred during an output overvoltage condition. If the output voltage is greater than approximately 7 V, the emitter-base junction of the series-pass element (internal or external) could break down and be damaged. To prevent this, a diode shunt can be used as shown in Figure 7.

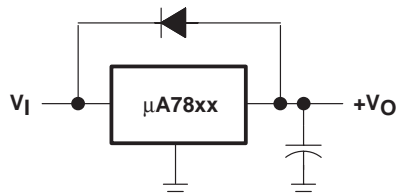

Figure 7. Reverse-Bias-Protection Circuit

PACKAGING INFORMATION

Orderable Device	Status ⁽¹⁾	Package Type	Package Drawing	Pins	Package Qty	Eco Plan ⁽²⁾	Lead/Ball Finish	MSL Peak Temp ⁽³⁾
UA7805CKC	ACTIVE	TO-220	KC	3	50	TBD	CU SNPB	Level-NC-NC-NC
UA7805CKCS	ACTIVE	TO-220	KCS	3	50	TBD	CU	Level-NC-NC-NC
UA7805CKTER	ACTIVE	PFM	KTE	3	2000	TBD	CU	Level-1-220C-UNLIM
UA7805QKC	OBSOLETE	TO-220	KC	3		TBD	Call TI	Call TI
UA7805QKTE	OBSOLETE	PFM	KTE	3		TBD	Call TI	Call TI
UA7806CKC	OBSOLETE	TO-220	KC	3		TBD	Call TI	Call TI
UA7806CKTER	OBSOLETE	PFM	KTE	3		TBD	Call TI	Call TI
UA7806QKTE	OBSOLETE	PFM	KTE	3		TBD	Call TI	Call TI
UA7806QKTER	OBSOLETE	PFM	KTE	3		TBD	Call TI	Call TI
UA7808CKC	ACTIVE	TO-220	KC	3	50	TBD	CU SNPB	Level-NC-NC-NC
UA7808CKCS	ACTIVE	TO-220	KCS	3	50	TBD	CU	Level-NC-NC-NC
UA7808CKTER	ACTIVE	PFM	KTE	3	2000	TBD	CU	Level-1-220C-UNLIM
UA7808QKTE	OBSOLETE	PFM	KTE	3		TBD	Call TI	Call TI
UA7810CKC	ACTIVE	TO-220	KC	3	50	TBD	CU SNPB	Level-NC-NC-NC
UA7810CKCS	ACTIVE	TO-220	KCS	3	50	TBD	CU SNPB	Level-NC-NC-NC
UA7810CKTER	ACTIVE	PFM	KTE	3	2000	TBD	CU	Level-1-220C-UNLIM
UA7810QKTE	OBSOLETE	PFM	KTE	3		TBD	Call TI	Call TI
UA7812CKC	ACTIVE	TO-220	KC	3	50	TBD	CU SNPB	Level-NC-NC-NC
UA7812CKCS	ACTIVE	TO-220	KCS	3	50	TBD	CU SNPB	Level-NC-NC-NC
UA7812CKTER	ACTIVE	PFM	KTE	3	2000	TBD	CU	Level-1-220C-UNLIM
UA7812QKTE	OBSOLETE	PFM	KTE	3		TBD	Call TI	Call TI
UA7815CKC	ACTIVE	TO-220	KC	3	50	TBD	CU SNPB	Level-NC-NC-NC
UA7815CKCS	ACTIVE	TO-220	KCS	3	50	TBD	CU	Level-NC-NC-NC
UA7815CKTER	ACTIVE	PFM	KTE	3	2000	TBD	CU	Level-1-220C-UNLIM
UA7815QKTE	OBSOLETE	PFM	KTE	3		TBD	Call TI	Call TI
UA7818CKC	OBSOLETE	TO-220	KC	3		TBD	Call TI	Call TI
UA7818CKTER	OBSOLETE	PFM	KTE	3		TBD	Call TI	Call TI
UA7824CKC	ACTIVE	TO-220	KC	3	50	TBD	CU SNPB	Level-NC-NC-NC
UA7824CKCS	ACTIVE	TO-220	KCS	3	50	TBD	CU SNPB	Level-NC-NC-NC
UA7824CKTER	ACTIVE	PFM	KTE	3	2000	TBD	CU	Level-1-220C-UNLIM
UA7885CKC	OBSOLETE	TO-220	KC	3		TBD	Call TI	Call TI
UA7885CKTER	OBSOLETE	PFM	KTE	3		TBD	Call TI	Call TI
UA7885QKTE	OBSOLETE	PFM	KTE	3		TBD	Call TI	Call TI

⁽¹⁾ The marketing status values are defined as follows:

ACTIVE: Product device recommended for new designs.

LIFEBUY: TI has announced that the device will be discontinued, and a lifetime-buy period is in effect.

NRND: Not recommended for new designs. Device is in production to support existing customers, but TI does not recommend using this part in a new design.

PREVIEW: Device has been announced but is not in production. Samples may or may not be available.

OBSOLETE: TI has discontinued the production of the device.

⁽²⁾ Eco Plan - The planned eco-friendly classification: Pb-Free (RoHS) or Green (RoHS & no Sb/Br) - please check <http://www.ti.com/productcontent> for the latest availability information and additional product content details.

TBD: The Pb-Free/Green conversion plan has not been defined.