

8-BIT BIDIRECTIONAL VOLTAGE-LEVEL TRANSLATOR FOR OPEN-DRAIN AND PUSH-PULL APPLICATIONS

FEATURES

- No Direction-Control Signal Needed
- Max Data Rates
 - 60 Mbps (Push Pull)
 - 2 Mbps (Open Drain)
- 1.2 V to 3.6 V on A Port and 1.65 V to 5.5 V on B Port ($V_{CCA} \leq V_{CCB}$)
- No Power-Supply Sequencing Required – Either V_{CCA} or V_{CCB} Can Be Ramped First
- Latch-Up Performance Exceeds 100 mA Per JESD 78, Class II
- ESD Protection Exceeds JESD 22 (A Port)
 - 2000-V Human-Body Model (A114-B)
 - 150-V Machine Model (A115-A)
 - 1000-V Charged-Device Model (C101)

- IEC 61000-4-2 ESD (B Port)
 - ± 8 -kV Contact Discharge
 - ± 6 -kV Air-Gap Discharge

ZXY PACKAGE
(BOTTOM VIEW)

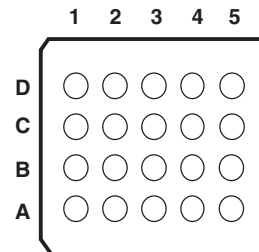

TERMINAL ASSIGNMENTS

	1	2	3	4	5
D	V_{CCB}	B2	B4	B6	B8
C	B1	B3	B5	B7	GND
B	A1	A3	A5	A7	OE
A	V_{CCA}	A2	A4	A6	A8

PW PACKAGE
(TOP VIEW)

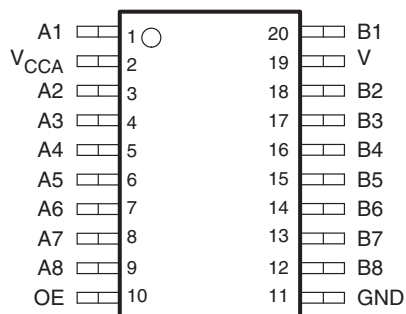

RGY PACKAGE
(TOP VIEW)

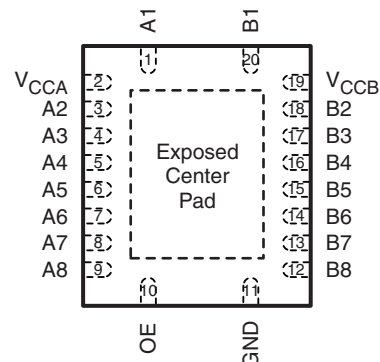

The exposed center pad, if used, must be connected as a secondary ground or left electrically open.



Please be aware that an important notice concerning availability, standard warranty, and use in critical applications of Texas Instruments semiconductor products and disclaimers thereto appears at the end of this data sheet.

DESCRIPTION/ORDERING INFORMATION

This 8-bit noninverting translator uses two separate configurable power-supply rails. The A port is designed to track V_{CCA} . V_{CCA} accepts any supply voltage from 1.2 V to 3.6 V. The B port is designed to track V_{CCB} . V_{CCB} accepts any supply voltage from 1.65 V to 5.5 V. This allows for low-voltage bidirectional translation between any of the 1.2-V, 1.5-V, 1.8-V, 2.5-V, 3.3-V, and 5-V voltage nodes.

When the output-enable (OE) input is low, all outputs are placed in the high-impedance state.

To ensure the high-impedance state during power up or power down, OE should be tied to GND through a pulldown resistor; the minimum value of the resistor is determined by the current-sourcing capability of the driver.

ORDERING INFORMATION

T _A	PACKAGE ⁽¹⁾⁽²⁾		ORDERABLE PART NUMBER	TOP-SIDE MARKING
–40°C to 85°C	QFN – RGY	Reel of 1000	TXS0108ERGYR	YF08E
	TSSOP – PW	Reel of 2000	TXS0108EPWR	YF08E
	UFBGA – ZXY	Reel of 2500	TXS0108EZXYR	YF08E

(1) Package drawings, thermal data, and symbolization are available at www.ti.com/packaging.

(2) For the most current package and ordering information, see the Package Option Addendum at the end of this document, or see the TI website at www.ti.com.

TYPICAL OPERATING CIRCUIT

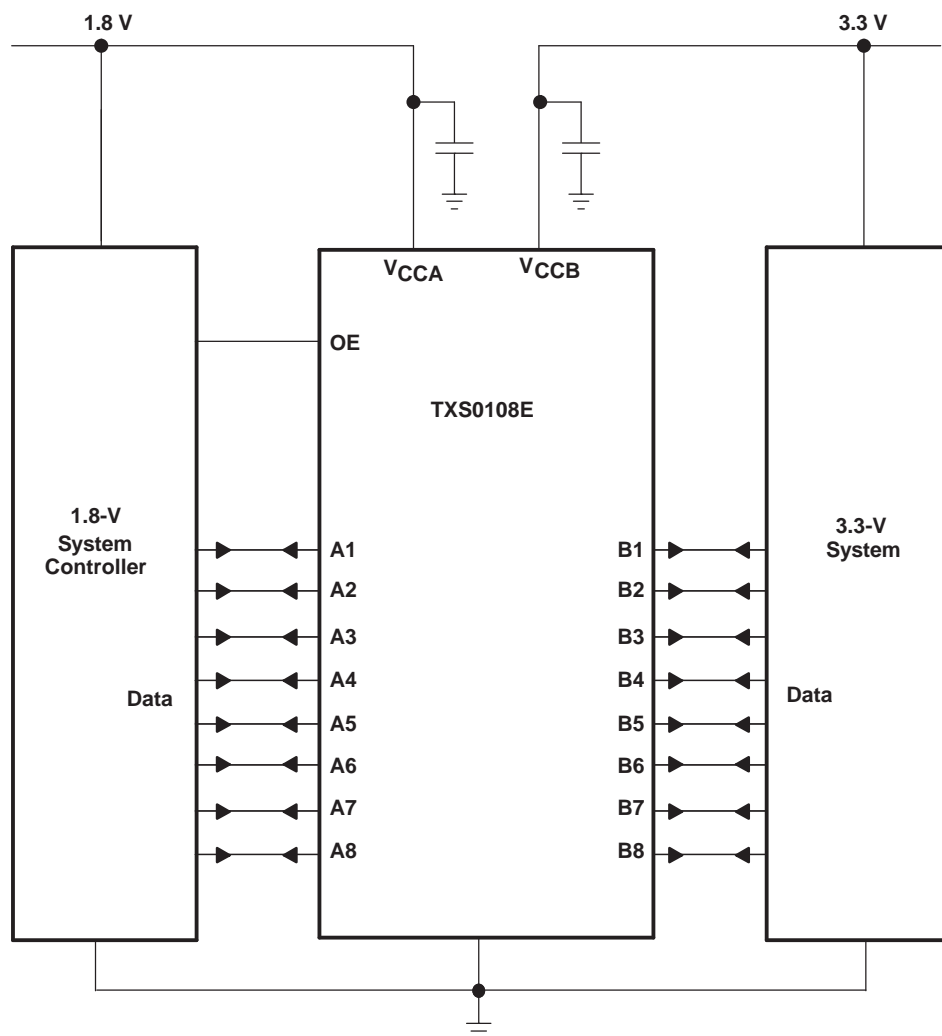

ABSOLUTE MAXIMUM RATINGS⁽¹⁾

over operating free-air temperature range (unless otherwise noted)

			MIN	MAX	UNIT
V_{CCA}	Supply voltage range		-0.5	4.6	V
V_{CCB}			-0.5	5.5	V
V_I	Input voltage range ⁽²⁾	A port	-0.5	4.6	V
		B port	-0.5	6.5	
V_O	Voltage range applied to any output in the high-impedance or power-off state ⁽²⁾	A port	-0.5	4.6	V
		B port	-0.5	6.5	
V_O	Voltage range applied to any output in the high or low state ⁽²⁾⁽³⁾	A port	-0.5	$V_{CCA} + 0.5$	V
		B port	-0.5	$V_{CCB} + 0.5$	
I_{IK}	Input clamp current	$V_I < 0$		-50	mA
I_{OK}	Output clamp current	$V_O < 0$		-50	mA
I_O	Continuous output current			±50	mA
	Continuous current through V_{CCA} , V_{CCB} , or GND			±100	mA
T_{stg}	Storage temperature range		-65	150	°C

- (1) Stresses beyond those listed under "absolute maximum ratings" may cause permanent damage to the device. These are stress ratings only, and functional operation of the device at these or any other conditions beyond those indicated under "recommended operating conditions" is not implied. Exposure to absolute-maximum-rated conditions for extended periods may affect device reliability.
- (2) The input and output negative-voltage ratings may be exceeded if the input and output current ratings are observed.
- (3) The value of V_{CCA} and V_{CCB} are provided in the recommended operating conditions table.

THERMAL IMPEDANCE RATINGS

			UNIT
θ_{JA}	Package thermal impedance	PW package ⁽¹⁾	70
		RGY package ⁽²⁾	80.9
		ZXY package ⁽¹⁾	47

- (1) The package thermal impedance is calculated in accordance with JESD 51-5.
- (2) The package thermal impedance is calculated in accordance with JESD 51-7.

RECOMMENDED OPERATING CONDITIONS⁽¹⁾⁽²⁾

		V_{CCA}	V_{CCB}	MIN	MAX	UNIT	
V_{CCA}	Supply voltage ⁽³⁾			1.2	3.6	V	
V_{CCB}				1.65	5.5		
V_{IH}	High-level input voltage	A-Port I/Os	1.2 V to 1.95 V 1.95 V to 3.6 V	1.65 V to 5.5 V	$V_{CCI} - 0.2$	V_{CCI}	V
					$V_{CCI} - 0.4$	V_{CCI}	
		B-Port I/Os OE	1.2 V to 3.6 V	1.65 V to 5.5 V	$V_{CCI} - 0.4$	V_{CCI}	
V_{IL}	Low-level input voltage	A-Port I/Os	1.2 V to 1.95 V 1.95 V to 3.6 V	1.65 V to 5.5 V	0	0.15	V
					0	0.15	
		B-Port I/Os OE	1.2 V to 3.6 V	1.65 V to 5.5 V	0	$V_{CCA} \times 0.35$	
$\Delta t/\Delta v$	Input transition rise or fall rate	A-Port I/Os push-pull driving	1.2 V to 3.6 V	1.65 V to 5.5 V		10	ns/V
		B-Port I/Os push-pull driving					
		Control input					
T_A	Operating free-air temperature			-40	85	°C	

(1) V_{CCI} is the V_{CC} associated with the data input port.

(2) V_{CCO} is the V_{CC} associated with the output port.

(3) V_{CCA} must be less than or equal to V_{CCB} , and V_{CCA} must not exceed 3.6 V.

ELECTRICAL CHARACTERISTICS⁽¹⁾⁽²⁾⁽³⁾

over recommended operating free-air temperature range (unless otherwise noted)

PARAMETER	TEST CONDITIONS	V _{CCA}	V _{CCB}	T _A = 25°C			–40°C to 85°C		UNIT		
				MIN	TYP	MAX	MIN	MAX			
V _{OHA}	I _{OH} = –20 μA, V _{IB} ≥ V _{CCB} – 0.4 V	1.2 V	1.65 V to 5.5 V	V _{CCA} × 0.67			V _{CCB} × 0.67		V		
		1.4 V to 3.6 V									
V _{OLA}	I _{OL} = 135 μA, V _{IB} ≤ 0.15 V	1.2 V	1.65 V to 5.5 V	0.25					V		
	I _{OL} = 180 μA, V _{IB} ≤ 0.15 V	1.4 V								0.4	
	I _{OL} = 220 μA, V _{IB} ≤ 0.15 V	1.65 V								0.4	
	I _{OL} = 300 μA, V _{IB} ≤ 0.15 V	2.3 V								0.4	
	I _{OL} = 400 μA, V _{IB} ≤ 0.15 V	3 V								0.55	
V _{OHB}	I _{OH} = –20 μA, V _{IA} ≥ V _{CCA} – 0.2 V	1.2 V	1.65 V to 5.5 V				V _{CCB} × 0.67		V		
		1.4 V to 3.6 V									
V _{OLB}	I _{OL} = 220 μA, V _{IA} ≤ 0.15 V	1.2 V to 3.6 V	1.65 V				0.4		V		
			2.3 V				0.4				
			3 V				0.55				
			4.5 V				0.55				
I _i	OE	V _i = V _{CC1} or GND	1.2 V	1.65 V to 5.5 V	±1			2	μA		
I _{OZ}	A or B port		1.2 V	1.65 V to 5.5 V	±1			±2	μA		
I _{CCA}	V _i = V _O = Open, I _O = 0		1.2 V	1.65 V to 5.5 V	1.5			±2	μA		
			1.4 V to 3.6 V	2.3 V to 5.5 V				2			
			3.6 V	0 V				2			
			0 V	5.5 V				–1			
I _{CCB}	V _i = V _O = Open, I _O = 0		1.2 V	1.65 V to 5.5 V	1.5				μA		
			1.4 V to 3.6 V	2.3 V to 5.5 V				6			
			3.6 V	0 V				–1			
			0 V	5.5 V				1			
I _{CCA} + I _{CCB}	V _i = V _{CC1} or GND, I _O = 0		1.2 V	2.3 V to 5.5 V	3				μA		
			1.4 V to 3.6 V					8			
I _{CCZA}	V _i = V _O = Open, I _O = 0, OE = GND		1.2 V	1.65 V to 5.5 V	0.05				μA		
			1.4 V to 3.6 V					2			
I _{CCZB}	V _i = V _O = Open, I _O = 0, OE = GND		1.2 V	1.65 V to 5.5 V	4				μA		
			1.4 V to 3.6 V					6			
C _i	OE		3.3 V	3.3 V	4.5			5.5	pF		
C _{io}	A port		3.3 V	3.3 V	6			7	pF		
	B port	5.5			6						

- (1) V_{CCO} is the V_{CC} associated with the output port.
- (2) V_{CC1} is the V_{CC} associated with the input port.
- (3) V_{CCA} must be less than or equal to V_{CCB}, and V_{CCA} must not exceed 3.6 V.

TIMING REQUIREMENTS

 $T_A = 25^\circ\text{C}$, $V_{CCA} = 1.2\text{ V}$

			$V_{CCB} = 1.8\text{ V}$	$V_{CCB} = 2.5\text{ V}$	$V_{CCB} = 3.3\text{ V}$	$V_{CCB} = 5\text{ V}$	UNIT
			TYP	TYP	TYP	TYP	
Data rate	Push-pull driving		20	20	20	20	Mbps
	Open-drain driving		2	2	2	2	
t_w Pulse duration	Push-pull driving		50	50	50	50	ns
	Open-drain driving		500	500	500	500	

TIMING REQUIREMENTS

 over recommended operating free-air temperature range, $V_{CCA} = 1.5\text{ V} \pm 0.1\text{ V}$ (unless otherwise noted)

			$V_{CCB} = 1.8\text{ V} \pm 0.15\text{ V}$		$V_{CCB} = 2.5\text{ V} \pm 0.2\text{ V}$		$V_{CCB} = 3.3\text{ V} \pm 0.3\text{ V}$		$V_{CCB} = 5\text{ V} \pm 0.5\text{ V}$		UNIT
			MIN	MAX	MIN	MAX	MIN	MAX	MIN	MAX	
Data rate	Push-pull driving		40		60		60		50		Mbps
	Open-drain driving		2		2		2		2		
t_w Pulse duration	Push-pull driving		25		16.7		16.7		20		ns
	Open-drain driving		500		500		500		500		

TIMING REQUIREMENTS

 over recommended operating free-air temperature range, $V_{CCA} = 1.8\text{ V} \pm 0.15\text{ V}$ (unless otherwise noted)

			$V_{CCB} = 1.8\text{ V} \pm 0.15\text{ V}$		$V_{CCB} = 2.5\text{ V} \pm 0.2\text{ V}$		$V_{CCB} = 3.3\text{ V} \pm 0.3\text{ V}$		$V_{CCB} = 5\text{ V} \pm 0.5\text{ V}$		UNIT
			MIN	MAX	MIN	MAX	MIN	MAX	MIN	MAX	
Data rate	Push-pull driving		40		60		60		60		Mbps
	Open-drain driving		2		2		2		2		
t_w Pulse duration	Push-pull driving		25		16.7		16.7		16.7		ns
	Open-drain driving		500		500		500		500		

TIMING REQUIREMENTS

 over recommended operating free-air temperature range, $V_{CCA} = 2.5\text{ V} \pm 0.2\text{ V}$ (unless otherwise noted)

			$V_{CCB} = 2.5\text{ V} \pm 0.2\text{ V}$		$V_{CCB} = 3.3\text{ V} \pm 0.3\text{ V}$		$V_{CC} = 5\text{ V} \pm 0.5\text{ V}$		UNIT
			MIN	MAX	MIN	MAX	MIN	MAX	
Data rate	Push-pull driving		60		60		60		Mbps
	Open-drain driving		2		2		2		
t_w Pulse duration	Push-pull driving		16.7		16.7		16.7		ns
	Open-drain driving		500		500		500		

TIMING REQUIREMENTS

 over recommended operating free-air temperature range, $V_{CCA} = 3.3\text{ V} \pm 0.3\text{ V}$ (unless otherwise noted)

			$V_{CCB} = 3.3\text{ V} \pm 0.3\text{ V}$		$V_{CC} = 5\text{ V} \pm 0.5\text{ V}$		UNIT
			MIN	MAX	MIN	MAX	
Data rate	Push-pull driving		60		60		Mbps
	Open-drain driving		2		2		
t_w Pulse duration	Push-pull driving		16.7		16.7		ns
	Open-drain driving		500		500		

SWITCHING CHARACTERISTICS

 over recommended operating free-air temperature range, $V_{CCA} = 1.2\text{ V}$ (unless otherwise noted)

PARAMETER	FROM (INPUT)	TO (OUTPUT)	TEST CONDITIONS	$V_{CCB} = 1.8\text{ V}$ $\pm 0.15\text{ V}$	$V_{CCB} = 2.5\text{ V}$ $\pm 0.2\text{ V}$	$V_{CCB} = 3.3\text{ V}$ $\pm 0.3\text{ V}$	$V_{CCB} = 5\text{ V}$ $\pm 0.5\text{ V}$	UNIT
				TYP	TYP	TYP	TYP	
t_{PHL}	A	B	Push-pull driving	6.5	5.9	5.7	5.5	ns
			Open-drain driving	11.9	11.1	11.0	11.1	
t_{PLH}			Push-pull driving	7.1	6.3	6.2	6.6	
			Open-drain driving	293	236	197	152	
t_{PHL}	B	A	Push-pull driving	6.4	6	5.8	5.6	ns
			Open-drain driving	8.5	6.8	6.2	5.9	
t_{PLH}			Push-pull driving	5.6	4.1	3.6	3.2	
			Open-drain driving	312	248	192	132	
t_{en}	OE	A or B	Push-pull driving	200	200	200	200	ns
t_{dis}	OE	A or B		16.8	13.9	13.2	13.5	ns
t_{rA}	A-port rise time		Push-pull driving	7.9	6.7	6.5	6.4	ns
			Open-drain driving	296	238	185	127	
t_{rB}	B-port rise time		Push-pull driving	6.3	3.3	1.8	1.5	ns
			Open-drain driving	236	164	115	60	
t_{fA}	A-port fall time		Push-pull driving	5.8	4.8	4.3	3.8	ns
			Open-drain driving	5.9	4.7	4.1	3.5	
t_{fB}	B-port fall time		Push-pull driving	4.6	2.8	2.2	1.9	ns
			Open-drain driving	4.5	2.7	2.2	1.9	
$t_{SK(O)}$	Channel-to-channel skew		Push-pull driving	1	1	1	1	ns
Max data rate	A or B		Push-pull driving	20	20	20	20	Mbps
			Open-drain driving	2	2	2	2	

SWITCHING CHARACTERISTICS

over recommended operating free-air temperature range, $V_{CCA} = 1.5 \text{ V} \pm 0.1 \text{ V}$ (unless otherwise noted)

PARAMETER	FROM (INPUT)	TO (OUTPUT)	TEST CONDITIONS	$V_{CCB} = 1.8 \text{ V}$ $\pm 0.15 \text{ V}$		$V_{CCB} = 2.5 \text{ V}$ $\pm 0.2 \text{ V}$		$V_{CCB} = 3.3 \text{ V}$ $\pm 0.3 \text{ V}$		$V_{CCB} = 5 \text{ V}$ $\pm 0.5 \text{ V}$		UNIT
				MIN	MAX	MIN	MAX	MIN	MAX	MIN	MAX	
t_{PHL}	A	B	Push-pull driving	11		9.2		8.6		8.6		ns
			Open-drain driving	4	14.4	3.6	12.8	3.5	12.2	3.5	12	
t_{PLH}			Push-pull driving	12		10		9.8		9.7		
			Open-drain driving	182	720	143	554	114	473	81	384	
t_{PHL}	B	A	Push-pull driving	12.7		11.1		11		12		ns
			Open-drain driving	3.4	13.2	3.1	9.6	2.8	8.5	2.5	7.5	
t_{PLH}			Push-pull driving	9.5		6.2		5.1		1.6		
			Open-drain driving	186	745	147	603	118	519	84	407	
t_{en}	OE	A or B	Push-pull driving	200		200		200		200		ns
t_{dis}	OE	A or B		28.1		22		20.1		19.6		ns
t_{rA}	A-port rise time		Push-pull driving	3.5	13.1	3	9.8	3.1	9	3.2	8.3	ns
			Open-drain driving	147	982	115	716	92	592	66	481	
t_{rB}	B-port rise time		Push-pull driving	2.9	11.4	1.9	7.4	0.9	4.7	0.7	2.6	ns
			Open-drain driving	135	1020	91	756	58	653	20	370	
t_{fA}	A-port fall time		Push-pull driving	2.3	9.9	1.7	7.7	1.6	6.8	1.7	6	ns
			Open-drain driving	2.4	10	2.1	7.9	1.7	7	1.5	6.2	
t_{fB}	B-port fall time		Push-pull driving	2	8.7	1.3	5.5	0.9	3.8	0.8	3.1	ns
			Open-drain driving	1.2	11.5	1.3	8.6	1	9.6	0.5	7.7	
$t_{SK(O)}$	Channel-to-channel skew		Push-pull driving	1		1	1	1.1		1		ns
Max data rate	A or B		Push-pull driving	40		60		60		50		Mbps
			Open-drain driving	2		2		2		2		

SWITCHING CHARACTERISTICS

 over recommended operating free-air temperature range, $V_{CCA} = 1.8 \text{ V} \pm 0.15 \text{ V}$ (unless otherwise noted)

PARAMETER	FROM (INPUT)	TO (OUTPUT)	TEST CONDITIONS	$V_{CCB} = 1.8 \text{ V} \pm 0.15 \text{ V}$		$V_{CCB} = 2.5 \text{ V} \pm 0.2 \text{ V}$		$V_{CCB} = 3.3 \text{ V} \pm 0.3 \text{ V}$		$V_{CCB} = 5 \text{ V} \pm 0.5 \text{ V}$		UNIT
				MIN	MAX	MIN	MAX	MIN	MAX	MIN	MAX	
t_{PHL}	A	B	Push-pull driving	8.2		6.4		5.7		5.6		ns
			Open-drain driving	3.6	11.4	3.2	9.9	3.1	9.3	3.1	8.9	
t_{PLH}			Push-pull driving	9		2.1		6.5		6.3		
			Open-drain driving	194	729	155	584	126	466	90	346	
t_{PHL}	B	A	Push-pull driving	9.8		8		7.4		7		ns
			Open-drain driving	3.4	12.1	2.8	8.5	2.5	7.3	2.1	6.2	
t_{PLH}			Push-pull driving	10.2		7		5.8		5		
			Open-drain driving	197	733	159	578	129	459	93	323	
t_{en}	OE	A or B	Push-pull driving	200		200		200		200		ns
t_{dis}	OE	A or B	Push-pull driving	25.1		18.8		16.5		15.3		ns
t_{rA}	A-port rise time		Push-pull driving	3.1	11.9	2.6	8.6	2.7	7.8	2.8	7.2	ns
			Open-drain driving	155	996	124	691	100	508	72	350	
t_{rB}	B-port rise time		Push-pull driving	2.8	10.5	1.8	7.2	1.2	5.2	0.7	2.7	ns
			Open-drain driving	132	1001	106	677	73	546	32	323	
t_{fA}	A-port fall time		Push-pull driving	2.1	8.8	1.6	6.6	1.4	5.7	1.4	4.9	ns
			Open-drain driving	2.2	9	1.7	6.7	1.4	5.8	1.2	5.2	
t_{fB}	B-port fall time		Push-pull driving	2	8.3	1.3	5.4	0.9	3.9	0.7	3	ns
			Open-drain driving	0.8	10.5	0.7	10.7	1	9.6	0.6	7.8	
$t_{SK(O)}$	Channel-to-channel skew		Push-pull driving	1		1		1		1		ns
Max data rate	A or B		Push-pull driving	40		60		60		60		Mbps
			Open-drain driving	2		2		2		2		

SWITCHING CHARACTERISTICS

over recommended operating free-air temperature range, $V_{CCA} = 2.5 \text{ V} \pm 0.2 \text{ V}$ (unless otherwise noted)

PARAMETER	FROM (INPUT)	TO (OUTPUT)	TEST CONDITIONS	$V_{CCB} = 2.5 \text{ V} \pm 0.2 \text{ V}$		$V_{CCB} = 3.3 \text{ V} \pm 0.3 \text{ V}$		$V_{CCB} = 5 \text{ V} \pm 0.5 \text{ V}$		UNIT
				MIN	MAX	MIN	MAX	MIN	MAX	
t_{PHL}	A	B	Push-pull driving	5		4		3.7		ns
			Open-drain driving	2.4	6.9	2.3	6.3	2.2	5.8	
t_{PLH}			Push-pull driving	5.2		4.3		3.9		
			Open-drain driving	149	592	125	488	93	368	
t_{PHL}	B	A	Push-pull driving	5.4		4.7		4.2		ns
			Open-drain driving	2.5	7.3	2.2	6	1.8	4.9	
t_{PLH}			Push-pull driving	5.9		4.4		3.5		
			Open-drain driving	150	595	126	481	94	345	
t_{en}	OE	A or B	Push-pull driving	200		200		200		ns
t_{dis}	OE	A or B		15.7		12.9		11.2		ns
t_{rA}	A-port rise time		Push-pull driving	2	7.3	2.1	6.4	2.2	5.8	ns
			Open-drain driving	110	692	93	529	68	369	
t_{rB}	B-port rise time		Push-pull driving	1.8	6.5	1.3	5.1	0.7	3.4	ns
			Open-drain driving	107	693	79	483	41	304	
t_{fA}	A-port fall time		Push-pull driving	1.5	5.7	1.2	4.7	1.3	3.8	ns
			Open-drain driving	1.5	5.6	1.2	4.7	1.1	4	
t_{fB}	B-port fall time		Push-pull driving	1.4	5.4	0.9	4.1	0.7	3	ns
			Open-drain driving	0.4	14.2	0.5	19.4	0.4	3	
$t_{SK(O)}$	Channel-to-channel skew		Push-pull driving	1		1.2		1		ns
Max data rate	A or B		Push-pull driving	60		60		60		Mbps
			Open-drain driving	2		2		2		

SWITCHING CHARACTERISTICS

 over recommended operating free-air temperature range, $V_{CCA} = 3.3 \text{ V} \pm 0.3 \text{ V}$ (unless otherwise noted)

PARAMETER	FROM (INPUT)	TO (OUTPUT)	TEST CONDITIONS	$V_{CCB} = 3.3 \text{ V} \pm 0.3 \text{ V}$		$V_{CCB} = 5 \text{ V} \pm 0.5 \text{ V}$		UNIT
				MIN	MAX	MIN	MAX	
t_{PHL}	A	B	Push-pull driving	3.8		3.1		ns
			Open-drain driving	2	5.3	1.9	4.8	
t_{PLH}			Push-pull driving	3.9		3.5		
			Open-drain driving	111	439	87	352	
t_{PHL}	B	A	Push-pull driving	4.2		3.8		ns
			Open-drain driving	2.1	5.5	1.7	4.5	
t_{PLH}			Push-pull driving	3.8		4.3		
			Open-drain driving	112	449	86	339	
t_{en}	OE	A or B	Push-pull driving	200		200		ns
t_{dis}	OE	A or B	Push-pull driving	11.9		9.8		ns
t_{rA}	A-port rise time		Push-pull driving	1.8	5.7	1.9	5	ns
			Open-drain driving	75	446	57	337	
t_{rB}	B-port rise time		Push-pull driving	1.5	5	1	3.6	ns
			Open-drain driving	72	427	40	290	
t_{fA}	A-port fall time		Push-pull driving	1.2	4.5	1.1	3.5	ns
			Open-drain driving	1.1	4.4	1	3.7	
t_{fB}	B-port fall time		Push-pull driving	1.1	4.2	0.8	3.1	ns
			Open-drain driving	1	4.2	0.8	3.1	
$t_{SK(O)}$	Channel-to-channel skew		Push-pull driving	1		1		ns
Max data rate	A or B		Push-pull driving	60		60		Mbps
			Open-drain driving	2		2		

OPERATING CHARACTERISTICS

 $T_A = 25^\circ\text{C}$

PARAMETER		TEST CONDITIONS	V_{CCA}						UNIT		
			1.2 V	1.2 V	1.5 V	1.8 V	2.5 V	2.5 V		3.3 V	
			V_{CCB}								
			5 V	1.8 V	1.8 V	1.8 V	2.5 V	5 V	3.3 V to 5 V		
			TYP	TYP	TYP	TYP	TYP	TYP	TYP		
C_{pdA}	A-port input, B-port output	$C_L = 0$, $f = 10 \text{ MHz}$, $t_r = t_f = 1 \text{ ns}$, $OE = V_{CCA}$ (outputs enabled)	5.9	5.7	5.9	5.9	6.7	6.9	8	pF	
	B-port input, A-port output		10.2	10.3	9.9	9.7	9.7	9.4	9.8		
C_{pdB}	A-port input, B-port output		29.9	22.2	21.5	20.8	21	23.4	23		
	B-port input, A-port output		22.9	16.7	16.7	16.8	17.8	20.8	20.9		
C_{pdA}	A-port input, B-port output		$C_L = 0$, $f = 10 \text{ MHz}$, $t_r = t_f = 1 \text{ ns}$, $OE = \text{GND}$ (outputs disabled)	0.01	0.01	0.01	0.01	0.01	0.01	0.01	pF
	B-port input, A-port output			0.06	0.01	0.01	0.01	0.01	0.01	0.01	
C_{pdB}	A-port input, B-port output			0.06	0.01	0.01	0.01	0.01	0.03	0.02	
	B-port input, A-port output			0.06	0.01	0.01	0.01	0.01	0.03	0.02	

PRINCIPLES OF OPERATION

Applications

The TXS0108E can be used in level-translation applications for interfacing devices or systems operating at different interface voltages with one another. The TXS0108E is ideal for use in applications where an open-drain driver is connected to the data I/Os. The TXS0108E can also be used in applications where a push-pull driver is connected to the data I/Os, but the TXB0104 might be a better option for such push-pull applications. The TXS0108E device is a semi-buffered auto-direction-sensing voltage translator design is optimized for translation applications (e.g. MMC Card Interfaces) that require the system to start out in a low-speed open-drain mode and then switch to a higher speed push-pull mode.

Architecture

To address these application requirements, a semi-buffered architecture design is used and is illustrated below (see Figure 1). Edge-rate accelerator circuitry (for both the high-to-low and low-to-high edges), a High-Ron n-channel pass-gate transistor (on the order of 300 Ω to 500 Ω) and pull-up resistors (to provide DC-bias and drive capabilities) are included to realize this solution. A direction-control signal (to control the direction of data flow from A to B or from B to A) is not needed. The resulting implementation supports both low-speed open-drain operation as well as high-speed push-pull operation.

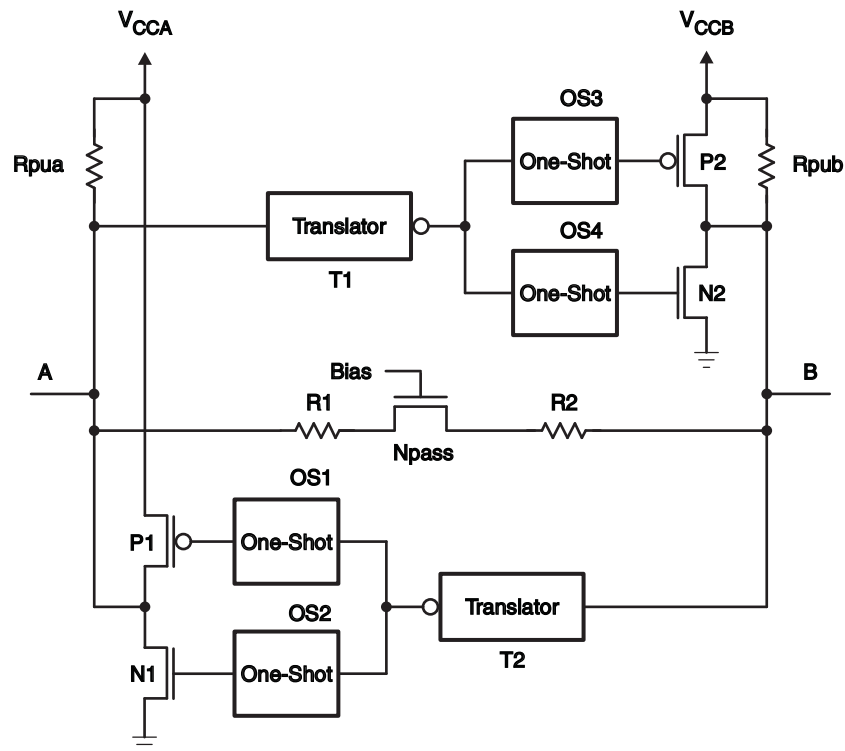

Figure 1. Architecture of a TXS01xx Cell

When transmitting data from A to B ports, during a rising edge the One-Shot (OS3) turns on the PMOS transistor (P2) for a short-duration and this speeds up the low-to-high transition. Similarly, during a falling edge, when transmitting data from A to B, the One-Shot (OS4) turns on NMOS transistor (N2) for a short-duration and this speeds up the high-to-low transition. The B-port edge-rate accelerator consists of one-shots OS3 and OS4, Transistors P2 and N2 and serves to rapidly force the B port high or low when a corresponding transition is detected on the A port.

When transmitting data from B to A ports, during a rising edge the One-Shot (OS1) turns on the PMOS transistor

(P1) for a short-duration and this speeds up the low-to-high transition. Similarly, during a falling edge, when transmitting data from B to A, the One-Shot (OS2) turns on NMOS transistor (N1) for a short-duration and this speeds up the high-to-low transition. The A-port edge-rate accelerator consists of one-shots OS1 and OS2, Transistors P1 and N1 components and form the edge-rate accelerator and serves to rapidly force the A port high or low when a corresponding transition is detected on the B port.

Power Up

During operation, ensure that $V_{CCA} \leq V_{CCB}$ at all times. During power-up sequencing, $V_{CCA} \geq V_{CCB}$ does not damage the device, so any power supply can be ramped up first.

Enable and Disable

The TXS0108E has an OE input that is used to disable the device by setting OE low, which places all I/Os in the Hi-Z state. The disable time (t_{dis}) indicates the delay between the time when OE goes low and when the outputs actually get disabled (Hi-Z). The enable time (t_{en}) indicates the amount of time the user must allow for the one-shot circuitry to become operational after OE is taken high.

Pullup or Pulldown Resistors on I/O Lines

Each A-port I/O has a pull-up resistor (R_{pua}) to V_{CCA} and each B-port I/O has a pull-up resistor (R_{pub}) to V_{CCB} . R_{pua} and R_{pub} have a value of 40 k Ω when the output is driving low. R_{pua} and R_{pub} have a value of 4 k Ω when the output is driving high. R_{pua} and R_{pub} are disabled when OE = Low.

PARAMETER MEASUREMENT INFORMATION

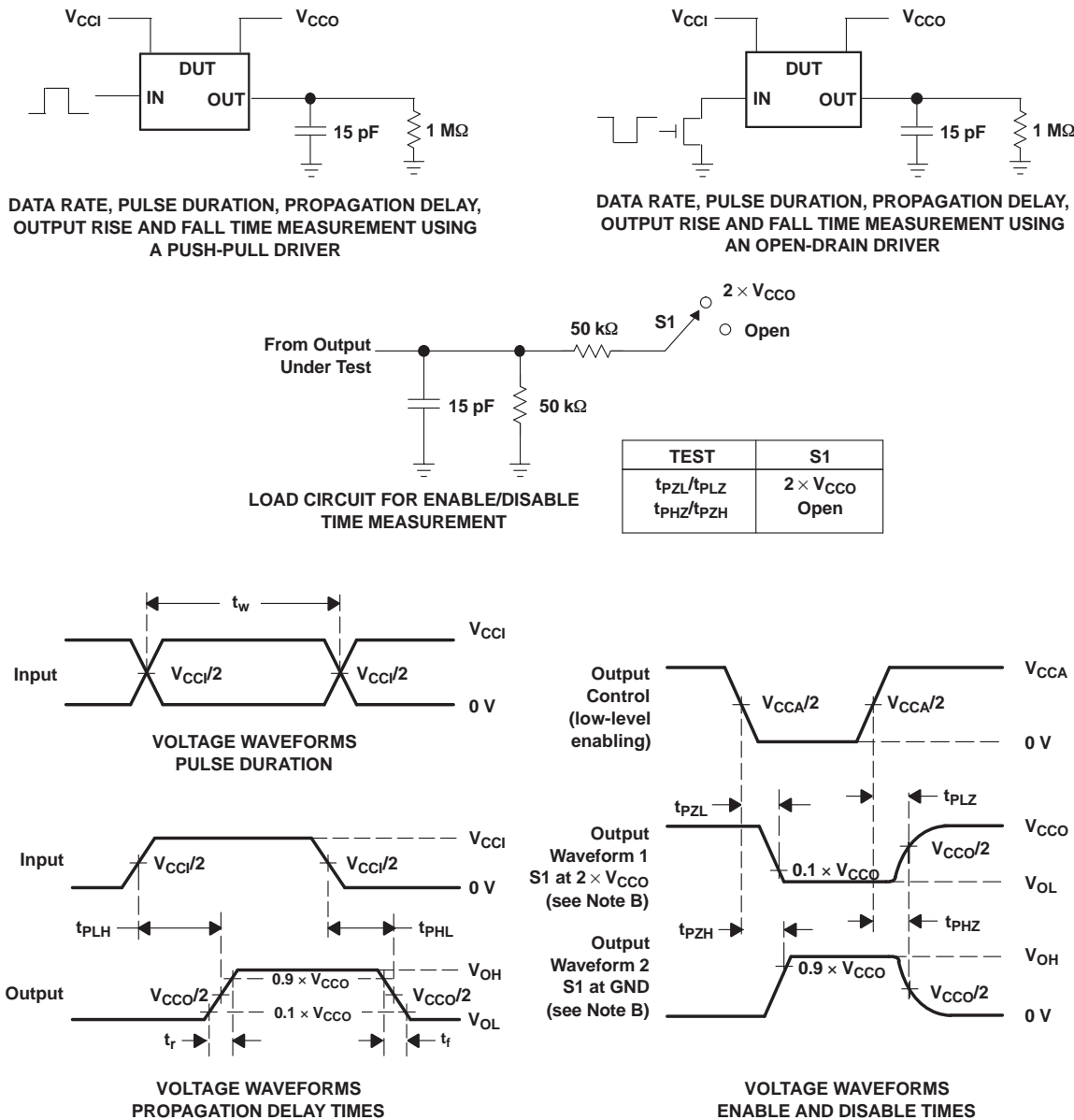

- A. C_L includes probe and jig capacitance.
- B. Waveform 1 is for an output with internal conditions such that the output is low, except when disabled by the output control. Waveform 2 is for an output with internal conditions such that the output is high, except when disabled by the output control.
- C. All input pulses are supplied by generators having the following characteristics: PRR \leq 10 MHz, $Z_O = 50 \Omega$, $dv/dt \geq 1$ V/ns.
- D. The outputs are measured one at a time, with one transition per measurement.
- E. t_{PLZ} and t_{PHZ} are the same as t_{dis} .
- F. t_{PZL} and t_{PZH} are the same as t_{en} .
- G. t_{PLH} and t_{PHL} are the same as t_{pd} .
- H. V_{CCI} is the V_{CC} associated with the input port.
- I. V_{CCO} is the V_{CC} associated with the output port.
- J. All parameters and waveforms are not applicable to all devices.

Figure 2. Load Circuit and Voltage Waveforms

PACKAGING INFORMATION

Orderable Device	Status ⁽¹⁾	Package Type	Package Drawing	Pins	Package Qty	Eco Plan ⁽²⁾	Lead/ Ball Finish	MSL Peak Temp ⁽³⁾	Samples (Requires Login)
TXS0108EPWR	ACTIVE	TSSOP	PW	20	2000	Green (RoHS & no Sb/Br)	CU NIPDAU	Level-1-260C-UNLIM	
TXS0108EPWRG4	ACTIVE	TSSOP	PW	20	2000	Green (RoHS & no Sb/Br)	CU NIPDAU	Level-1-260C-UNLIM	
TXS0108ERGYR	ACTIVE	VQFN	RGY	20	3000	Green (RoHS & no Sb/Br)	CU NIPDAU	Level-2-260C-1 YEAR	
TXS0108EZXYR	ACTIVE	BGA MICROSTAR JUNIOR	ZXY	20	2500	Green (RoHS & no Sb/Br)	SNAGCU	Level-1-260C-UNLIM	

⁽¹⁾ The marketing status values are defined as follows:

ACTIVE: Product device recommended for new designs.

LIFEBUY: TI has announced that the device will be discontinued, and a lifetime-buy period is in effect.

NRND: Not recommended for new designs. Device is in production to support existing customers, but TI does not recommend using this part in a new design.

PREVIEW: Device has been announced but is not in production. Samples may or may not be available.

OBSELETE: TI has discontinued the production of the device.

⁽²⁾ Eco Plan - The planned eco-friendly classification: Pb-Free (RoHS), Pb-Free (RoHS Exempt), or Green (RoHS & no Sb/Br) - please check <http://www.ti.com/productcontent> for the latest availability information and additional product content details.

TBD: The Pb-Free/Green conversion plan has not been defined.

Pb-Free (RoHS): TI's terms "Lead-Free" or "Pb-Free" mean semiconductor products that are compatible with the current RoHS requirements for all 6 substances, including the requirement that lead not exceed 0.1% by weight in homogeneous materials. Where designed to be soldered at high temperatures, TI Pb-Free products are suitable for use in specified lead-free processes.

Pb-Free (RoHS Exempt): This component has a RoHS exemption for either 1) lead-based flip-chip solder bumps used between the die and package, or 2) lead-based die adhesive used between the die and leadframe. The component is otherwise considered Pb-Free (RoHS compatible) as defined above.

Green (RoHS & no Sb/Br): TI defines "Green" to mean Pb-Free (RoHS compatible), and free of Bromine (Br) and Antimony (Sb) based flame retardants (Br or Sb do not exceed 0.1% by weight in homogeneous material)

⁽³⁾ MSL, Peak Temp. -- The Moisture Sensitivity Level rating according to the JEDEC industry standard classifications, and peak solder temperature.

Important Information and Disclaimer: The information provided on this page represents TI's knowledge and belief as of the date that it is provided. TI bases its knowledge and belief on information provided by third parties, and makes no representation or warranty as to the accuracy of such information. Efforts are underway to better integrate information from third parties. TI has taken and continues to take reasonable steps to provide representative and accurate information but may not have conducted destructive testing or chemical analysis on incoming materials and chemicals. TI and TI suppliers consider certain information to be proprietary, and thus CAS numbers and other limited information may not be available for release.

In no event shall TI's liability arising out of such information exceed the total purchase price of the TI part(s) at issue in this document sold by TI to Customer on an annual basis.

TAPE AND REEL INFORMATION
REEL DIMENSIONS

TAPE DIMENSIONS

A0	Dimension designed to accommodate the component width
B0	Dimension designed to accommodate the component length
K0	Dimension designed to accommodate the component thickness
W	Overall width of the carrier tape
P1	Pitch between successive cavity centers

TAPE AND REEL INFORMATION

*All dimensions are nominal

Device	Package Type	Package Drawing	Pins	SPQ	Reel Diameter (mm)	Reel Width W1 (mm)	A0 (mm)	B0 (mm)	K0 (mm)	P1 (mm)	W (mm)	Pin1 Quadrant
TXS0108EPWR	TSSOP	PW	20	2000	330.0	16.4	6.95	7.1	1.6	8.0	16.0	Q1
TXS0108ERGYR	VQFN	RGY	20	3000	330.0	12.4	3.8	4.8	1.6	8.0	12.0	Q1
TXS0108EZXYR	BGA MICROSTAR JUNIOR	ZXY	20	2500	330.0	12.4	2.8	3.3	1.0	4.0	12.0	Q2

TAPE AND REEL BOX DIMENSIONS

*All dimensions are nominal

Device	Package Type	Package Drawing	Pins	SPQ	Length (mm)	Width (mm)	Height (mm)
TXS0108EPWR	TSSOP	PW	20	2000	367.0	367.0	38.0
TXS0108ERGYR	VQFN	RGY	20	3000	367.0	367.0	35.0
TXS0108EZXYR	BGA MICROSTAR JUNIOR	ZXY	20	2500	340.5	338.1	20.6

ZXY (S-PBGA-N20)

PLASTIC BALL GRID ARRAY

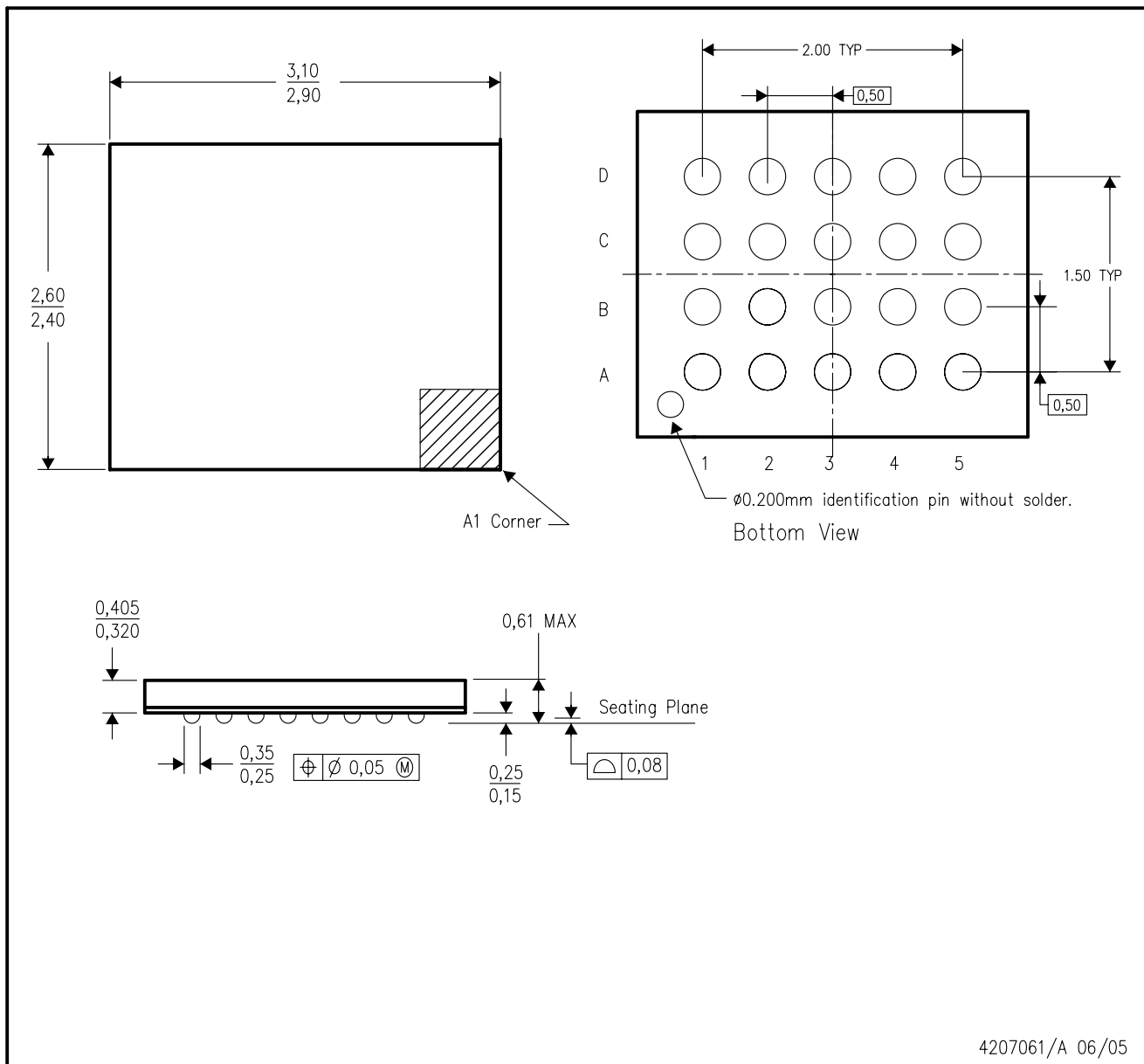

- NOTES:
- A. All linear dimensions are in millimeters.
 - B. This drawing is subject to change without notice.
 - C. This package is a lead-free solder ball design.

PW (R-PDSO-G20)

PLASTIC SMALL OUTLINE

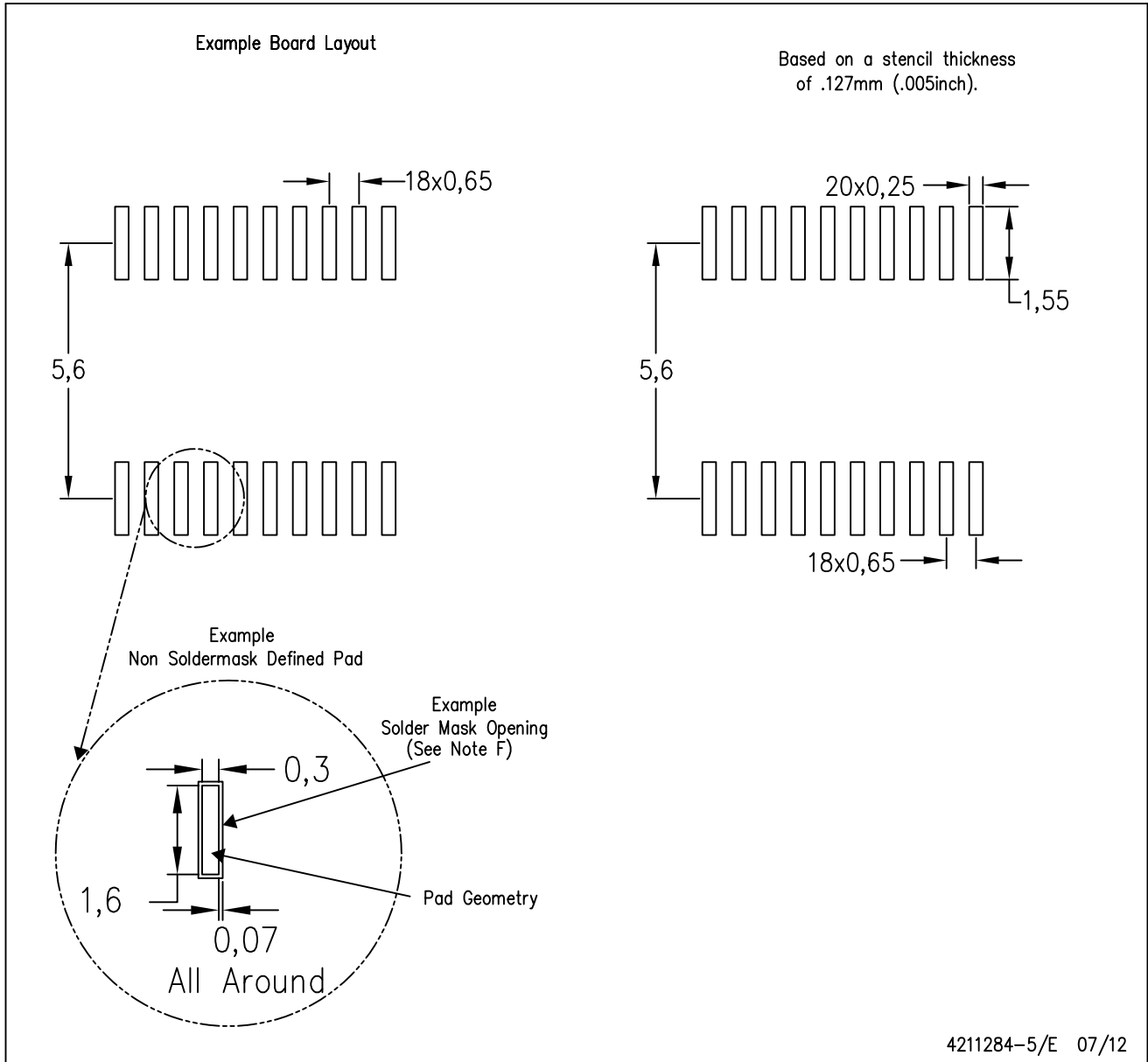

- NOTES:
- A. All linear dimensions are in millimeters.
 - B. This drawing is subject to change without notice.
 - C. Publication IPC-7351 is recommended for alternate design.
 - D. Laser cutting apertures with trapezoidal walls and also rounding corners will offer better paste release. Customers should contact their board assembly site for stencil design recommendations. Refer to IPC-7525 for other stencil recommendations.
 - E. Customers should contact their board fabrication site for solder mask tolerances between and around signal pads.

RGY (R-PVQFN-N20)

PLASTIC QUAD FLATPACK NO-LEAD

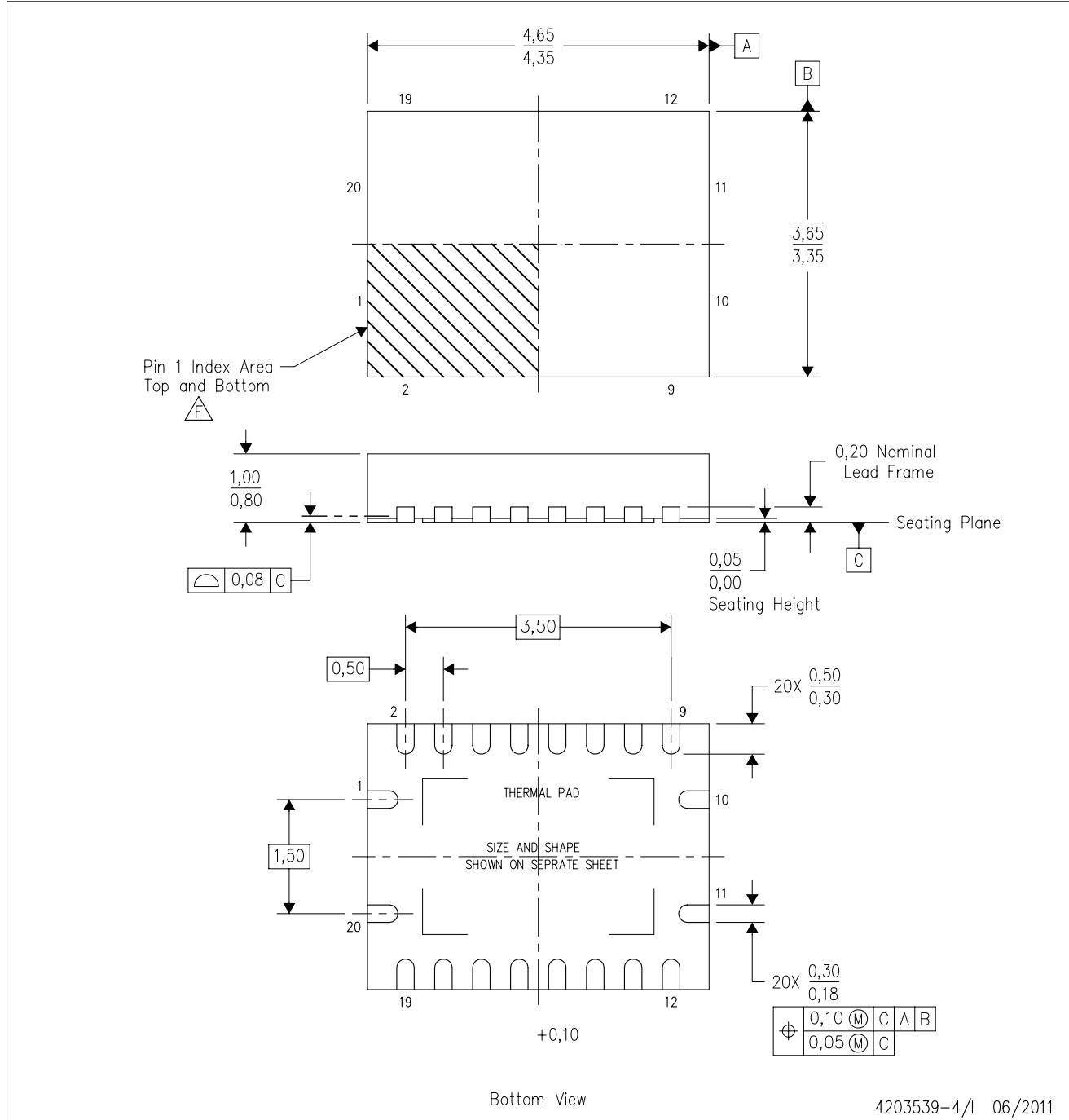

- NOTES:
- A. All linear dimensions are in millimeters. Dimensioning and tolerancing per ASME Y14.5M-1994.
 - B. This drawing is subject to change without notice.
 - C. QFN (Quad Flatpack No-Lead) package configuration.
 - D. The package thermal pad must be soldered to the board for thermal and mechanical performance.
 - E. See the additional figure in the Product Data Sheet for details regarding the exposed thermal pad features and dimensions.
 - F. Pin 1 identifiers are located on both top and bottom of the package and within the zone indicated. The Pin 1 identifiers are either a molded, marked, or metal feature.
 - G. Package complies to JEDEC MO-241 variation BA.

RGY (R-PVQFN-N20)

PLASTIC QUAD FLATPACK NO-LEAD

THERMAL INFORMATION

This package incorporates an exposed thermal pad that is designed to be attached directly to an external heatsink. The thermal pad must be soldered directly to the printed circuit board (PCB). After soldering, the PCB can be used as a heatsink. In addition, through the use of thermal vias, the thermal pad can be attached directly to the appropriate copper plane shown in the electrical schematic for the device, or alternatively, can be attached to a special heatsink structure designed into the PCB. This design optimizes the heat transfer from the integrated circuit (IC).

For information on the Quad Flatpack No-Lead (QFN) package and its advantages, refer to Application Report, QFN/SON PCB Attachment, Texas Instruments Literature No. SLUA271. This document is available at www.ti.com.

The exposed thermal pad dimensions for this package are shown in the following illustration.

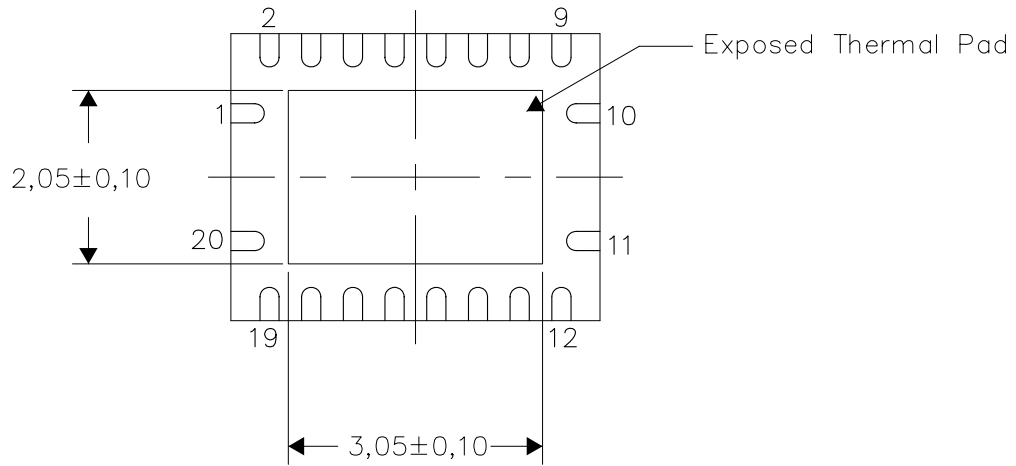

Bottom View

Exposed Thermal Pad Dimensions

4206353-4/0 11/11

NOTE: All linear dimensions are in millimeters

RGY (R-PVQFN-N20)

PLASTIC QUAD FLATPACK NO-LEAD

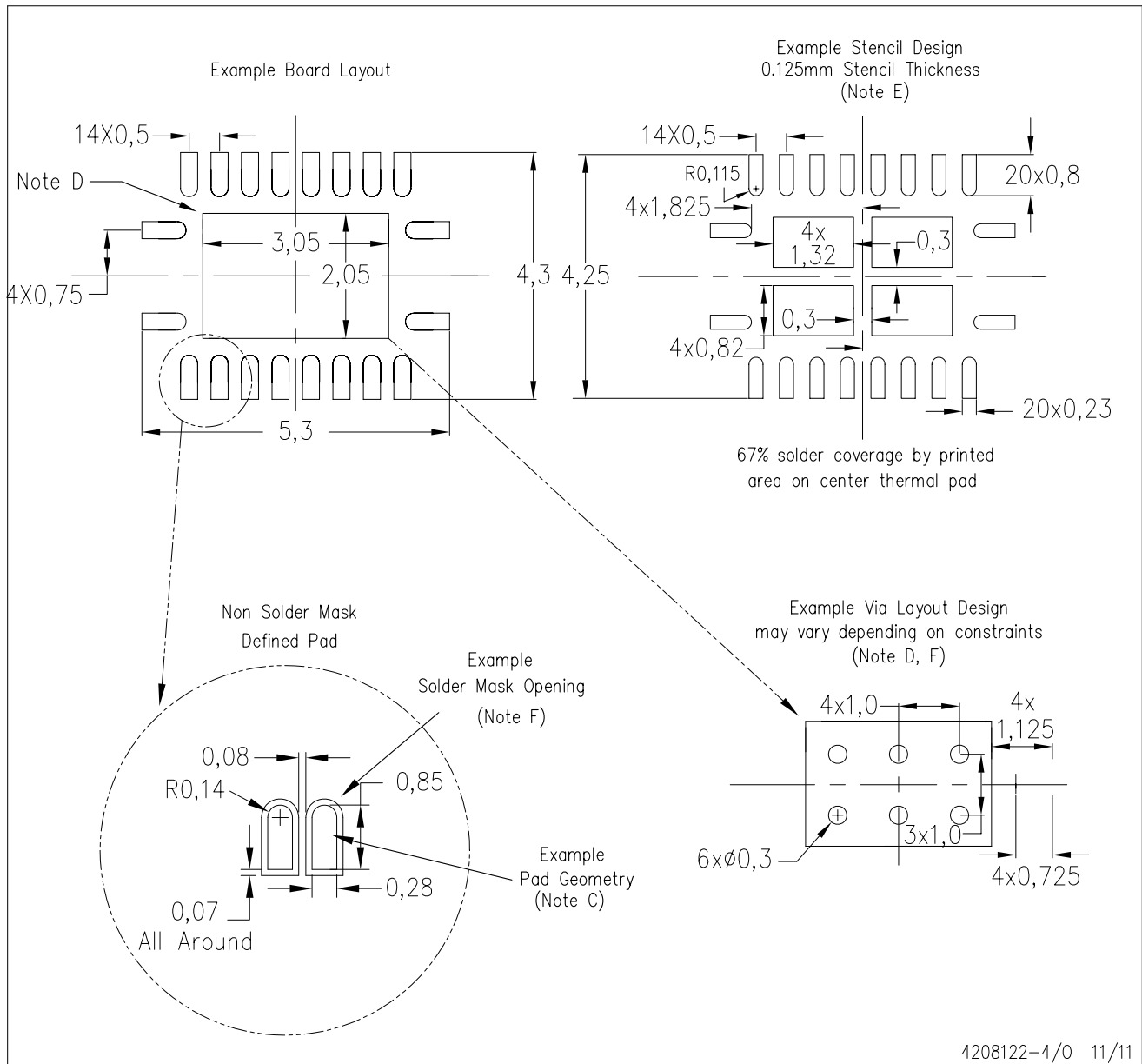

- NOTES:
- A. All linear dimensions are in millimeters.
 - B. This drawing is subject to change without notice.
 - C. Publication IPC-7351 is recommended for alternate designs.
 - D. This package is designed to be soldered to a thermal pad on the board. Refer to Application Note, Quad Flat-Pack QFN/SON PCB Attachment, Texas Instruments Literature No. SLUA271, and also the Product Data Sheets for specific thermal information, via requirements, and recommended board layout. These documents are available at www.ti.com <<http://www.ti.com>>.
 - E. Laser cutting apertures with trapezoidal walls and also rounding corners will offer better paste release. Customers should contact their board assembly site for stencil design recommendations. Refer to IPC 7525 for stencil design considerations.
 - F. Customers should contact their board fabrication site for minimum solder mask web tolerances between signal pads.

IMPORTANT NOTICE

Texas Instruments Incorporated and its subsidiaries (TI) reserve the right to make corrections, enhancements, improvements and other changes to its semiconductor products and services per JESD46C and to discontinue any product or service per JESD48B. Buyers should obtain the latest relevant information before placing orders and should verify that such information is current and complete. All semiconductor products (also referred to herein as "components") are sold subject to TI's terms and conditions of sale supplied at the time of order acknowledgment.

TI warrants performance of its components to the specifications applicable at the time of sale, in accordance with the warranty in TI's terms and conditions of sale of semiconductor products. Testing and other quality control techniques are used to the extent TI deems necessary to support this warranty. Except where mandated by applicable law, testing of all parameters of each component is not necessarily performed.

TI assumes no liability for applications assistance or the design of Buyers' products. Buyers are responsible for their products and applications using TI components. To minimize the risks associated with Buyers' products and applications, Buyers should provide adequate design and operating safeguards.

TI does not warrant or represent that any license, either express or implied, is granted under any patent right, copyright, mask work right, or other intellectual property right relating to any combination, machine, or process in which TI components or services are used. Information published by TI regarding third-party products or services does not constitute a license to use such products or services or a warranty or endorsement thereof. Use of such information may require a license from a third party under the patents or other intellectual property of the third party, or a license from TI under the patents or other intellectual property of TI.

Reproduction of significant portions of TI information in TI data books or data sheets is permissible only if reproduction is without alteration and is accompanied by all associated warranties, conditions, limitations, and notices. TI is not responsible or liable for such altered documentation. Information of third parties may be subject to additional restrictions.

Resale of TI components or services with statements different from or beyond the parameters stated by TI for that component or service voids all express and any implied warranties for the associated TI component or service and is an unfair and deceptive business practice. TI is not responsible or liable for any such statements.

Buyer acknowledges and agrees that it is solely responsible for compliance with all legal, regulatory and safety-related requirements concerning its products, and any use of TI components in its applications, notwithstanding any applications-related information or support that may be provided by TI. Buyer represents and agrees that it has all the necessary expertise to create and implement safeguards which anticipate dangerous consequences of failures, monitor failures and their consequences, lessen the likelihood of failures that might cause harm and take appropriate remedial actions. Buyer will fully indemnify TI and its representatives against any damages arising out of the use of any TI components in safety-critical applications.

In some cases, TI components may be promoted specifically to facilitate safety-related applications. With such components, TI's goal is to help enable customers to design and create their own end-product solutions that meet applicable functional safety standards and requirements. Nonetheless, such components are subject to these terms.

No TI components are authorized for use in FDA Class III (or similar life-critical medical equipment) unless authorized officers of the parties have executed a special agreement specifically governing such use.

Only those TI components which TI has specifically designated as military grade or "enhanced plastic" are designed and intended for use in military/aerospace applications or environments. Buyer acknowledges and agrees that any military or aerospace use of TI components which have **not** been so designated is solely at the Buyer's risk, and that Buyer is solely responsible for compliance with all legal and regulatory requirements in connection with such use.

TI has specifically designated certain components which meet ISO/TS16949 requirements, mainly for automotive use. Components which have not been so designated are neither designed nor intended for automotive use; and TI will not be responsible for any failure of such components to meet such requirements.

Products

Audio	www.ti.com/audio
Amplifiers	amplifier.ti.com
Data Converters	dataconverter.ti.com
DLP® Products	www.dlp.com
DSP	dsp.ti.com
Clocks and Timers	www.ti.com/clocks
Interface	interface.ti.com
Logic	logic.ti.com
Power Mgmt	power.ti.com
Microcontrollers	microcontroller.ti.com
RFID	www.ti-rfid.com
OMAP Mobile Processors	www.ti.com/omap
Wireless Connectivity	www.ti.com/wirelessconnectivity

Applications

Automotive and Transportation	www.ti.com/automotive
Communications and Telecom	www.ti.com/communications
Computers and Peripherals	www.ti.com/computers
Consumer Electronics	www.ti.com/consumer-apps
Energy and Lighting	www.ti.com/energy
Industrial	www.ti.com/industrial
Medical	www.ti.com/medical
Security	www.ti.com/security
Space, Avionics and Defense	www.ti.com/space-avionics-defense
Video and Imaging	www.ti.com/video

TI E2E Community e2e.ti.com