

TXS0108E面向开漏和推挽应用的 8 位双向电压电平转换 转换器

1 特性

- 无需方向控制信号
- 最大数据速率
 - 110Mbps (推挽)
 - 1.2Mbps (开漏)
- A 端口 1.2V 至 3.6V; B 端口 1.65V 至 5.5V ($V_{CCA} \leq V_{CCB}$)
- 无需电源排序 - V_{CCA} 或 V_{CCB} 均可优先斜升
- 锁断性能超过 100mA, 符合 JESD 78 II 类规范的要求
- 静电放电 (ESD) 保护性能超过 JESD 22 规范的要求 (A 端口)
 - 2000V 人体放电模式 (A114-B)
 - 150V 机器模型 (A115-A)
 - 1000V 充电器件模型 (C101)
- IEC 61000-4-2 ESD (B 端口)
 - $\pm 8kV$ 接触放电
 - $\pm 6kV$ 气隙放电

2 应用

- 手持终端
- 智能电话
- 平板电脑
- 台式计算机

3 说明

这款 8 位非反向转换器使用两个独立的可配置电源轨。A 端口跟踪 V_{CCA} 引脚的电源电压。 V_{CCA} 引脚可接受 1.2V 到 3.6V 范围内的任意电源电压。B 端口跟踪 V_{CCB} 引脚的电源电压。 V_{CCB} 引脚可接受 1.65V 到 5.5V 范围内的任意电源电压。这两个输入电源引脚可实现 1.2V、1.8V、2.5V、3.3V 和 5V 电压节点之间的任意低压双向转换。

输出使能 (OE) 输入为低电平时, 所有输出均将置于高阻抗 (Hi-Z) 状态。

为确保输出在上电或断电期间处于 Hi-Z 状态, 需通过一个下拉电阻将 OE 接至 GND。该电阻的最小值取决于驱动器的拉电流能力。

器件信息⁽¹⁾

器件型号	封装	封装尺寸 (标称值)
TXS0108E	TSSOP (20)	6.50mm x 6.40mm
	VQFN (20)	4.50mm x 3.50mm
	UFBGA (20)	3.00mm x 2.50mm

(1) 如需了解所有可用封装, 请参见数据表末尾的可订购产品附录。

简化应用

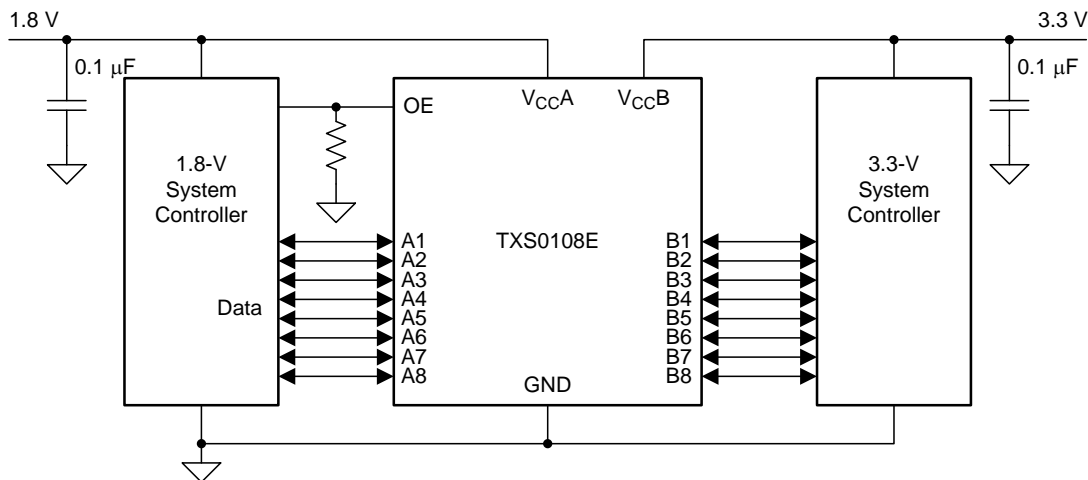

目录

1	特性	1	6.17	Typical Characteristics	14
2	应用	1	7	Parameter Measurement Information	15
3	说明	1	7.1	Load Circuits	15
4	修订历史记录	2	7.2	Voltage Waveforms	16
5	Pin Configuration and Functions	3	8	Detailed Description	17
6	Specifications	4	8.1	Overview	17
6.1	Absolute Maximum Ratings	4	8.2	Functional Block Diagram	17
6.2	ESD Ratings	4	8.3	Feature Description	17
6.3	Recommended Operating Conditions	5	8.4	Device Functional Modes	19
6.4	Thermal Information	5	9	Application and Implementation	20
6.5	Electrical Characteristics	6	9.1	Application Information	20
6.6	Timing Requirements: $V_{CCA} = 1.2\text{ V}$	7	9.2	Typical Application	20
6.7	Timing Requirements: $V_{CCA} = 1.5\text{ V} \pm 0.1\text{ V}$	7	10	Power Supply Recommendations	22
6.8	Timing Requirements: $V_{CCA} = 1.8\text{ V} \pm 0.15\text{ V}$	8	11	Layout	22
6.9	Timing Requirements: $V_{CCA} = 2.5\text{ V} \pm 0.2\text{ V}$	8	11.1	Layout Guidelines	22
6.10	Timing Requirements: $V_{CCA} = 3.3\text{ V} \pm 0.3\text{ V}$	8	11.2	Layout Example	22
6.11	Switching Characteristics: $V_{CCA} = 1.2\text{ V}$	9	12	器件和文档支持	23
6.12	Switching Characteristics: $V_{CCA} = 1.5\text{ V} \pm 0.1\text{ V}$..	10	12.1	社区资源	23
6.13	Switching Characteristics: $V_{CCA} = 1.8\text{ V} \pm 0.15\text{ V}$..	11	12.2	商标	23
6.14	Switching Characteristics: $V_{CCA} = 2.5\text{ V} \pm 0.2\text{ V}$..	12	12.3	静电放电警告	23
6.15	Switching Characteristics: $V_{CCA} = 3.3\text{ V} \pm 0.3\text{ V}$..	13	12.4	Glossary	23
6.16	Operating Characteristics	13	13	机械、封装和可订购信息	23

4 修订历史记录

Changes from Revision C (December 2014) to Revision D

Page

- | | | |
|---|---------------------|---|
| • | 已更改 ESD 额定值表, | 1 |
|---|---------------------|---|

Changes from Revision B (November 2013) to Revision C

Page

- | | | |
|---|--|---|
| • | 已添加 引脚配置和功能部分, ESD 额定值表, 特性 描述 部分, 器件功能模式, 应用和实施部分, 电源相关建议部分, 布局部分, 器件和文档支持部分以及机械、封装和可订购信息部分 | 1 |
|---|--|---|

5 Pin Configuration and Functions

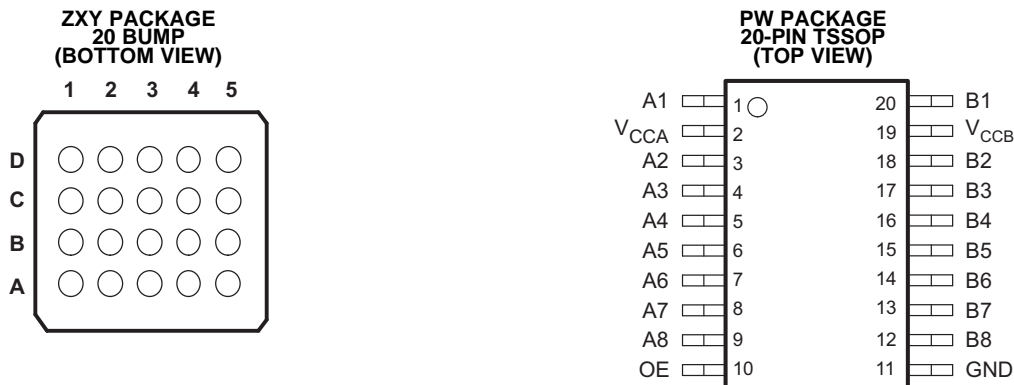

The exposed center pad, if used, must be connected as a secondary ground or left electrically open.

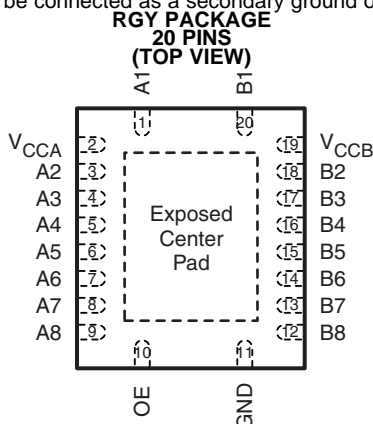

Pin Assignments

	1	2	3	4	5
D	V _{CCB}	B2	B4	B6	B8
C	B1	B3	B5	B7	GND
B	A1	A3	A5	A7	OE
A	V _{CCA}	A2	A4	A6	A8

Pin Functions

NAME	PIN NO.		TYPE	DESCRIPTION
	PW, RGY	ZXY		
A1	1	B1	I/O	Input/output 1. Referenced to V _{CCA}
A2	3	A2	I/O	Input/output 2. Referenced to V _{CCA}
A3	4	B2	I/O	Input/output 3. Referenced to V _{CCA}
A4	5	A3	I/O	Input/output 4. Referenced to V _{CCA}
A5	6	B3	I/O	Input/output 5. Referenced to V _{CCA}
A6	7	A4	I/O	Input/output 6. Referenced to V _{CCA}
A7	8	B4	I/O	Input/output 7. Referenced to V _{CCA}
A8	9	A5	I/O	Input/output 8. Referenced to V _{CCA}
B1	20	C 1	I/O	Input/output 1. Referenced to V _{CCB}
B2	18	D2	I/O	Input/output 2. Referenced to V _{CCB}
B3	17	C2	I/O	Input/output 3. Referenced to V _{CCB}
B4	16	D3	I/O	Input/output 4. Referenced to V _{CCB}

Pin Functions (continued)

PIN NO.			TYPE	DESCRIPTION
NAME	PW, RGY	ZXY		
B5	15	C3	I/O	Input/output 5. Referenced to V_{CCB}
B6	14	D4	I/O	Input/output 6. Referenced to V_{CCB}
B7	13	C4	I/O	Input/output 7. Referenced to V_{CCB}
B8	12	D5	I/O	Input/output 8. Referenced to V_{CCB}
GND	11	C5	S	Ground
OE	10	B5	I	3-state output-mode enable. Pull OE low to place all outputs in 3-state mode. Referenced to V_{CCA} .
V_{CCA}	2	A1	S	A-port supply voltage. $1.2\text{ V} \leq V_{CCA} \leq 3.6\text{ V}$, $V_{CCA} \leq V_{CCB}$.
V_{CCB}	19	D1	S	B-port supply voltage. $1.65\text{ V} \leq V_{CCB} \leq 5.5\text{ V}$.
Thermal Pad			—	For the RGY package, the exposed center thermal pad must be connected to ground

6 Specifications

6.1 Absolute Maximum Ratings⁽¹⁾

over operating free-air temperature range (unless otherwise noted)

			MIN	MAX	UNIT	
V_{CCA}	Supply voltage		-0.5	4.6	V	
V_{CCB}			-0.5	5.5	V	
V_I	Input voltage ⁽²⁾	A port	-0.5	4.6	V	
		B port	-0.5	6.5		
V_O	Voltage range applied to any output in the high-impedance or power-off state ⁽²⁾	A port	-0.5	4.6	V	
		B port	-0.5	6.5		
V_O	Voltage range applied to any output in the high or low state ^{(2) (3)}	A port	-0.5	$V_{CCA} + 0.5$	V	
		B port	-0.5	$V_{CCB} + 0.5$		
I_{IK}	Input clamp current	$V_I < 0$		-50	mA	
I_{OK}	Output clamp current	$V_O < 0$		-50	mA	
I_O	Continuous output current			-50	50	mA
	Continuous current through V_{CCA} , V_{CCB} , or GND			-100	100	mA
T_{stg}	Storage temperature			-65	150	°C

- (1) Stresses beyond those listed under Absolute Maximum Ratings may cause permanent damage to the device. These are stress ratings only, and functional operation of the device at these or any other conditions beyond those indicated under *Recommended Operating Conditions* is not implied. Exposure to absolute-maximum-rated conditions for extended periods may affect device reliability.
- (2) The input and output negative Voltage ratings may be exceeded if the input and output current ratings are observed.
- (3) The value of V_{CCA} and V_{CCB} are provided in the recommended operating conditions table.

6.2 ESD Ratings

			VALUE	UNIT
$V_{(ESD)}$	Electrostatic discharge	Human body model (HBM), per ANSI/ESDA/JEDEC JS-001 ⁽¹⁾	±2000	V
		Charged-device model (CDM), per JEDEC specification JESD22-C101 ⁽²⁾	±1000	
		Machine model (MM)	±150	
		IEC 61000-4-2 ESD (B Port) Contact Discharge	±8000	
		IEC 61000-4-2 ESD (B Port) Air-Gap Discharge	±6000	

- (1) JEDEC document JEP155 states that 500 V HBM allows safe manufacturing with a standard ESD control process.
- (2) JEDEC document JEP157 states that 250 V CDM allows safe manufacturing with a standard ESD control process.

6.3 Recommended Operating Conditions

over operating free-air temperature range (unless otherwise noted)⁽¹⁾⁽²⁾

			V _{CCA} (V)	V _{CCB} (V)	MIN	MAX	UNIT
V _{CCA}	Supply voltage ⁽³⁾			1.2		3.6	V
V _{CCB}				1.65		5.5	
V _{IH}	High-level input voltage	A-Port I/Os	1.2 to 1.95	1.65 to 5.5	V _{CCI} – 0.2	V _{CCI}	V
			1.95 to 3.6		V _{CCI} – 0.4	V _{CCI}	
		B-Port I/Os	1.2 to 3.6		V _{CCI} – 0.4	V _{CCI}	
			OE		V _{CCA} × 0.65	5.5	
V _{IL}	Low-level input voltage	A-Port I/Os	1.2 to 1.95		0	0.15	V
			1.95 to 3.6		0	0.15	
		B-Port I/Os	1.2 to 3.6		0	0.15	
			OE		0	V _{CCA} × 0.35	
Δt/Δv	Input transition rise or fall rate	A-Port I/Os Push-pull	1.2 to 3.6			10	ns/V
		B-Port I/Os Push-pull					
		Control input					
T _A	Operating free-air temperature			–40	125	°C	

(1) V_{CCI} is the V_{CC} associated with the data input port.

(2) V_{CCO} is the V_{CC} associated with the output port.

(3) V_{CCA} must be less than or equal to V_{CCB}, and V_{CCA} must not exceed 3.6 V.

6.4 Thermal Information

THERMAL METRIC ⁽¹⁾		TXS0108E			UNIT
		PW (TSSOP)	RGY	ZXY	
		20 PINS	20 PINS	20 PINS	
R _{θJA}	Junction-to-ambient thermal resistance	101.5	34.7	101.5	°C/W
R _{θJC(top)}	Junction-to-case (top) thermal resistance	35.9	39.5	35.9	
R _{θJB}	Junction-to-board thermal resistance	52.4	12.7	52.4	
Ψ _{JT}	Junction-to-top characterization parameter	2.3	0.9	2.3	
Ψ _{JB}	Junction-to-board characterization parameter	51.9	12.7	51.9	
R _{θJC(bot)}	Junction-to-case (bottom) thermal resistance	—	7.5	—	

(1) For more information about traditional and new thermal metrics, see the *IC Package Thermal Metrics* application report, [SPRA953](#).

6.5 Electrical Characteristics⁽¹⁾⁽²⁾⁽³⁾

over recommended operating free-air temperature range (unless otherwise noted)

PARAMETER	TEST CONDITIONS	V _{CCA} (V)	V _{CCB} (V)	T _A = 25°C			T _A = –40°C to 85°C		UNIT	
				MIN	TYP	MAX	MIN	MAX		
V _{OHA}	I _{OH} = –20 μA, V _{IB} ≥ V _{CCB} – 0.4 V	1.2	1.65 to 5.5	V _{CCA} × 0.67					V	
V _{OLA}	I _{OL} = 135 μA, V _{IB} ≤ 0.15 V	1.2	1.65 to 5.5			0.25			V	
	I _{OL} = 180 μA, V _{IB} ≤ 0.15 V	1.4					0.4			
	I _{OL} = 220 μA, V _{IB} ≤ 0.15 V	1.65					0.4			
	I _{OL} = 300 μA, V _{IB} ≤ 0.15 V	2.3					0.4			
	I _{OL} = 400 μA, V _{IB} ≤ 0.15 V	3					0.55			
V _{OHB}	I _{OH} = –20 μA, V _{IA} ≥ V _{CCA} – 0.2 V	1.2	1.65 to 5.5	V _{CCB} × 0.67					V	
V _{OLB}	I _{OL} = 220 μA, V _{IA} ≤ 0.15 V	1.2 to 3.6	1.65				0.4	V		
	I _{OL} = 300 μA, V _{IA} ≤ 0.15 V		2.3				0.4			
	I _{OL} = 400 μA, V _{IA} ≤ 0.15 V		3				0.55			
	I _{OL} = 620 μA, V _{IA} ≤ 0.15 V		4.5				0.55			
I _I	OE	V _I = V _{CCI} or GND	1.2	1.65 to 5.5	–1		1	2	μA	
I _{OZ}	A or B port		1.2	1.65 to 5.5	–1		1	–2	2	μA
I _{CCA}	V _I = V _O = Open, I _O = 0	1.2	1.65 to 5.5		1.5		–2	2	μA	
		1.5 to 3.6	2.3 to 5.5					2		
		3.6	0					2		
		0	5.5					–1		
I _{CCB}	V _I = V _O = Open, I _O = 0	1.2	1.65 to 5.5		1.5				μA	
		1.5 to 3.6	2.3 to 5.5					6		
		3.6	0					–1		
		0	5.5					1.2		
I _{CCA} + I _{CCB}	V _I = V _{CCI} or GND, I _O = 0	1.2	2.3 to 5.5		3				μA	
		1.5 to 3.6					8			
I _{CCZA}	V _I = V _O = Open, I _O = 0, OE = GND	1.2	1.65 to 5.5		0.05				μA	
I _{CCZB}	V _I = V _O = Open, I _O = 0, OE = GND	1.2	1.65 to 5.5		4				μA	
C _i	OE		3.3	3.3		4.5		5.5	pF	
C _{io}	A port		3.3	3.3		6		7	pF	
	B port					5.5		6		

- (1) V_{CCO} is the V_{CC} associated with the output port.
- (2) V_{CCI} is the V_{CC} associated with the input port.
- (3) V_{CCA} must be less than or equal to V_{CCB}, and V_{CCA} must not exceed 3.6 V.

6.6 Timing Requirements: $V_{CCA} = 1.2\text{ V}$

 $T_A = 25^\circ\text{C}$, $V_{CCA} = 1.2\text{ V}$

			$V_{CCB}\text{ (V)}$				UNIT
			1.8 (TYP)	2.5 (TYP)	3.3 (TYP)	5 (TYP)	
Data rate	Push-pull		20	20	20	20	Mbps
	Open-drain		2	2	2	2	
t_w Pulse duration	Push-pull	Data inputs	50	50	50	50	ns
	Open-drain		500	500	500	500	

6.7 Timing Requirements: $V_{CCA} = 1.5\text{ V} \pm 0.1\text{ V}$

 over recommended operating free-air temperature range, $V_{CCA} = 1.5\text{ V} \pm 0.1\text{ V}$ (unless otherwise noted)

			$V_{CCB} = 1.8\text{ V} \pm 0.15\text{ V}$		$V_{CCB} = 2.5\text{ V} \pm 0.2\text{ V}$		$V_{CCB} = 3.3\text{ V} \pm 0.3\text{ V}$		$V_{CCB} = 5\text{ V} \pm 0.5\text{ V}$		UNIT
			MIN	MAX	MIN	MAX	MIN	MAX	MIN	MAX	
Data rate	Push-pull	40		60		60		50		Mbps	
	Open-drain	2		2		2		2			
t_w Pulse duration	Push-pull	25		16.7		16.7		20		ns	
	Open-drain	500		500		500		500			

6.8 Timing Requirements: $V_{CCA} = 1.8\text{ V} \pm 0.15\text{ V}$

 over recommended operating free-air temperature range, $V_{CCA} = 1.8\text{ V} \pm 0.15\text{ V}$ (unless otherwise noted)

			$V_{CCB} = 1.8\text{ V} \pm 0.15\text{ V}$		$V_{CCB} = 2.5\text{ V} \pm 0.2\text{ V}$		$V_{CCB} = 3.3\text{ V} \pm 0.3\text{ V}$		$V_{CCB} = 5\text{ V} \pm 0.5\text{ V}$		UNIT
			MIN	MAX	MIN	MAX	MIN	MAX	MIN	MAX	
	Data rate	Push-pull	40		60		60		60		Mbps
		Open-drain	2		2		2		2		
t_w	Pulse duration	Push-pull	25		16.7		16.7		16.7		ns
		Open-drain	500		500		500		500		

6.9 Timing Requirements: $V_{CCA} = 2.5\text{ V} \pm 0.2\text{ V}$

 over recommended operating free-air temperature range, $V_{CCA} = 2.5\text{ V} \pm 0.2\text{ V}$ (unless otherwise noted)

			$V_{CCB} = 2.5\text{ V} \pm 0.2\text{ V}$		$V_{CCB} = 3.3\text{ V} \pm 0.3\text{ V}$		$V_{CC} = 5\text{ V} \pm 0.5\text{ V}$		UNIT
			MIN	MAX	MIN	MAX	MIN	MAX	
	Data rate	Push-pull	60		60		60		Mbps
		Open-drain	2		2		2		
t_w	Pulse duration	Push-pull	16.7		16.7		16.7		ns
		Open-drain	500		500		500		

6.10 Timing Requirements: $V_{CCA} = 3.3\text{ V} \pm 0.3\text{ V}$

 over recommended operating free-air temperature range, $V_{CCA} = 3.3\text{ V} \pm 0.3\text{ V}$ (unless otherwise noted)

			$V_{CCB} = 3.3\text{ V} \pm 0.3\text{ V}$		$V_{CC} = 5\text{ V} \pm 0.5\text{ V}$		UNIT
			MIN	MAX	MIN	MAX	
	Data rate	Push-pull	60		60		Mbps
		Open-drain	2		2		
t_w	Pulse duration	Push-pull	16.7		16.7		ns
		Open-drain	500		500		

6.11 Switching Characteristics: $V_{CCA} = 1.2\text{ V}$

over recommended operating free-air temperature range, $V_{CCA} = 1.2\text{ V}$ (unless otherwise noted)

PARAMETER	FROM (INPUT)	TO (OUTPUT)	TEST CONDITION (DRIVING)	$V_{CCB} = 1.8\text{ V} \pm 0.15\text{ V}$	$V_{CCB} = 2.5\text{ V} \pm 0.2\text{ V}$	$V_{CCB} = 3.3\text{ V} \pm 0.3\text{ V}$	$V_{CCB} = 5\text{ V} \pm 0.5\text{ V}$	UNIT
				TYP	TYP	TYP	TYP	
t_{PHL}	A	B	Push-pull	6.5	5.9	5.7	5.5	ns
			Open-drain	11.9	11.1	11.0	11.1	
t_{PLH}			Push-pull	7.1	6.3	6.2	6.6	
			Open-drain	293	236	197	152	
t_{PHL}	B	A	Push-pull	6.4	6	5.8	5.6	ns
			Open-drain	8.5	6.8	6.2	5.9	
t_{PLH}			Push-pull	5.6	4.1	3.6	3.2	
			Open-drain	312	248	192	132	
t_{en}	OE	A or B	Push-pull	200	200	200	200	ns
t_{dis}	OE	A or B	Push-pull	16.8	13.9	13.2	13.5	ns
t_{rA}	A-port rise time		Push-pull	7.9	6.7	6.5	6.4	ns
			Open-drain	296	238	185	127	
t_{rB}	B-port rise time		Push-pull	6.3	3.3	1.8	1.5	ns
			Open-drain	236	164	115	60	
t_{fA}	A-port fall time		Push-pull	5.8	4.8	4.3	3.8	ns
			Open-drain	5.9	4.7	4.1	3.5	
t_{fB}	B-port fall time		Push-pull	4.6	2.8	2.2	1.9	ns
			Open-drain	4.5	2.7	2.2	1.9	
$t_{SK(O)}$	Channel-to-channel skew		Push-pull	1	1	1	1	ns
Max data rate	A or B		Push-pull	20	20	20	20	Mbps
			Open-drain	2	2	2	2	

6.12 Switching Characteristics: $V_{CCA} = 1.5\text{ V} \pm 0.1\text{ V}$

 over recommended operating free-air temperature range, $V_{CCA} = 1.5\text{ V} \pm 0.1\text{ V}$ (unless otherwise noted)

PARAMETER	FROM (INPUT)	TO (OUTPUT)	TEST CONDITION (DRIVING)	$V_{CCB} = 1.8\text{ V} \pm 0.15\text{ V}$		$V_{CCB} = 2.5\text{ V} \pm 0.2\text{ V}$		$V_{CCB} = 3.3\text{ V} \pm 0.3\text{ V}$		$V_{CCB} = 5\text{ V} \pm 0.5\text{ V}$		UNIT
				MIN	MAX	MIN	MAX	MIN	MAX	MIN	MAX	
t_{PHL}	A	B	Push-pull		11		9.2		8.6		8.6	ns
			Open-drain	4	14.4	3.6	12.8	3.5	12.2	3.5	12	
t_{PLH}			Push-pull		12		10		9.8		9.7	
			Open-drain	182	720	143	554	114	473	81	384	
t_{PHL}	B	A	Push-pull		12.7		11.1		11		12	ns
			Open-drain	3.4	13.2	3.1	9.6	2.8	8.5	2.5	7.5	
t_{PLH}			Push-pull		9.5		6.2		5.1		1.6	
			Open-drain	186	745	147	603	118	519	84	407	
t_{en}	OE	A or B	Push-pull		200		200		200		200	ns
t_{dis}	OE	A or B			28.1		22		20.1		19.6	ns
t_{rA}	A-port rise time		Push-pull	3.5	13.1	3	9.8	3.1	9	3.2	8.3	ns
			Open-drain	147	982	115	716	92	592	66	481	
t_{rB}	B-port rise time		Push-pull	2.9	11.4	1.9	7.4	0.9	4.7	0.7	2.6	ns
			Open-drain	135	1020	91	756	58	653	20	370	
t_{fA}	A-port fall time		Push-pull	2.3	9.9	1.7	7.7	1.6	6.8	1.7	6	ns
			Open-drain	2.4	10	2.1	7.9	1.7	7	1.5	6.2	
t_{fB}	B-port fall time		Push-pull	2	8.7	1.3	5.5	0.9	3.8	0.8	3.1	ns
			Open-drain	1.2	11.5	1.3	8.6	1	9.6	0.5	7.7	
$t_{SK(O)}$	Channel-to-channel skew		Push-pull		1	1	1		1.1		1	ns
Max data rate	A or B		Push-pull	40		60		60		50		Mbps
			Open-drain	2		2		2		2		

6.13 Switching Characteristics: $V_{CCA} = 1.8 \text{ V} \pm 0.15 \text{ V}$

 over recommended operating free-air temperature range, $V_{CCA} = 1.8 \text{ V} \pm 0.15 \text{ V}$ (unless otherwise noted)

PARAMETER	FROM (INPUT)	TO (OUTPUT)	TEST CONDITION (DRIVING)	$V_{CCB} = 1.8 \text{ V} \pm 0.15 \text{ V}$		$V_{CCB} = 2.5 \text{ V} \pm 0.2 \text{ V}$		$V_{CCB} = 3.3 \text{ V} \pm 0.3 \text{ V}$		$V_{CCB} = 5 \text{ V} \pm 0.5 \text{ V}$		UNIT
				MIN	MAX	MIN	MAX	MIN	MAX	MIN	MAX	
t_{PHL}	A	B	Push-pull		8.2		6.4		5.7		5.6	ns
			Open-drain	3.6	11.4	3.2	9.9	3.1	9.3	3.1	8.9	
t_{PLH}			Push-pull		9		2.1		6.5		6.3	
			Open-drain	194	729	155	584	126	466	90	346	
t_{PHL}	B	A	Push-pull		9.8		8		7.4		7	ns
			Open-drain	3.4	12.1	2.8	8.5	2.5	7.3	2.1	6.2	
t_{PLH}			Push-pull		10.2		7		5.8		5	
			Open-drain	197	733	159	578	129	459	93	323	
t_{en}	OE	A or B	Push-pull		200		200		200		200	ns
t_{dis}	OE	A or B			25.1		18.8		16.5		15.3	ns
t_{rA}	A-port rise time		Push-pull	3.1	11.9	2.6	8.6	2.7	7.8	2.8	7.2	ns
			Open-drain	155	996	124	691	100	508	72	350	
t_{rB}	B-port rise time		Push-pull	2.8	10.5	1.8	7.2	1.2	5.2	0.7	2.7	ns
			Open-drain	132	1001	106	677	73	546	32	323	
t_{fA}	A-port fall time		Push-pull	2.1	8.8	1.6	6.6	1.4	5.7	1.4	4.9	ns
			Open-drain	2.2	9	1.7	6.7	1.4	5.8	1.2	5.2	
t_{fB}	B-port fall time		Push-pull	2	8.3	1.3	5.4	0.9	3.9	0.7	3	ns
			Open-drain	0.8	10.5	0.7	10.7	1	9.6	0.6	7.8	
$t_{SK(O)}$	Channel-to-channel skew		Push-pull		1		1		1		1	ns
Max data rate	A or B		Push-pull		40		60		60		60	Mbps
			Open-drain		2		2		2		2	

6.14 Switching Characteristics: $V_{CCA} = 2.5\text{ V} \pm 0.2\text{ V}$

 over recommended operating free-air temperature range, $V_{CCA} = 2.5\text{ V} \pm 0.2\text{ V}$ (unless otherwise noted)

PARAMETER	FROM (INPUT)	TO (OUTPUT)	TEST CONDITION (DRIVING)	$V_{CCB} = 2.5\text{ V} \pm 0.2\text{ V}$		$V_{CCB} = 3.3\text{ V} \pm 0.3\text{ V}$		$V_{CCB} = 5\text{ V} \pm 0.5\text{ V}$		UNIT
				MIN	MAX	MIN	MAX	MIN	MAX	
t_{PHL}	A	B	Push-pull		5		4		3.7	ns
			Open-drain	2.4	6.9	2.3	6.3	2.2	5.8	
t_{PLH}			Push-pull		5.2		4.3		3.9	
			Open-drain	149	592	125	488	93	368	
t_{PHL}	B	A	Push-pull		5.4		4.7		4.2	ns
			Open-drain	2.5	7.3	2.2	6	1.8	4.9	
t_{PLH}			Push-pull		5.9		4.4		3.5	
			Open-drain	150	595	126	481	94	345	
t_{en}	OE	A or B	Push-pull		200		200		200	ns
t_{dis}	OE	A or B			15.7		12.9		11.2	ns
t_{rA}	A-port rise time		Push-pull	2	7.3	2.1	6.4	2.2	5.8	ns
			Open-drain	110	692	93	529	68	369	
t_{rB}	B-port rise time		Push-pull	1.8	6.5	1.3	5.1	0.7	3.4	ns
			Open-drain	107	693	79	483	41	304	
t_{fA}	A-port fall time		Push-pull	1.5	5.7	1.2	4.7	1.3	3.8	ns
			Open-drain	1.5	5.6	1.2	4.7	1.1	4	
t_{fB}	B-port fall time		Push-pull	1.4	5.4	0.9	4.1	0.7	3	
			Open-drain	0.4	14.2	0.5	19.4	0.4	3	
$t_{SK(O)}$	Channel-to-channel skew		Push-pull		1		1.2		1	ns
Max data rate	A or B		Push-pull	60		60		60		Mbps
			Open-drain	2		2		2		

6.15 Switching Characteristics: $V_{CCA} = 3.3 \text{ V} \pm 0.3 \text{ V}$

over recommended operating free-air temperature range, $V_{CCA} = 3.3 \text{ V} \pm 0.3 \text{ V}$ (unless otherwise noted)

PARAMETER	FROM (INPUT)	TO (OUTPUT)	TEST CONDITION (DRIVING)	$V_{CCB} = 3.3 \text{ V} \pm 0.3 \text{ V}$		$V_{CCB} = 5 \text{ V} \pm 0.5 \text{ V}$		UNIT
				MIN	MAX	MIN	MAX	
t_{PHL}	A	B	Push-pull		3.8		3.1	ns
			Open-drain	2	5.3	1.9	4.8	
t_{PLH}			Push-pull		3.9		3.5	
			Open-drain	111	439	87	352	
t_{PHL}	B	A	Push-pull		4.2		3.8	ns
			Open-drain	2.1	5.5	1.7	4.5	
t_{PLH}			Push-pull		3.8		4.3	
			Open-drain	112	449	86	339	
t_{en}	OE	A or B	Push-pull		200		200	ns
t_{dis}	OE	A or B			11.9		9.8	ns
t_{rA}	A-port rise time		Push-pull	1.8	5.7	1.9	5	ns
			Open-drain	75	446	57	337	
t_{rB}	B-port rise time		Push-pull	1.5	5	1	3.6	ns
			Open-drain	72	427	40	290	
t_{fA}	A-port fall time		Push-pull	1.2	4.5	1.1	3.5	ns
			Open-drain	1.1	4.4	1	3.7	
t_{fB}	B-port fall time		Push-pull	1.1	4.2	0.8	3.1	ns
			Open-drain	1	4.2	0.8	3.1	
$t_{SK(O)}$	Channel-to-channel skew		Push-pull		1		1	ns
Max data rate	A or B		Push-pull	60		60		Mbps
			Open-drain	2		2		

6.16 Operating Characteristics

 $T_A = 25^\circ\text{C}$

PARAMETER		TEST CONDITIONS	V_{CCA}						UNIT			
			1.2 V	1.2 V	1.5 V	1.8 V	2.5 V	2.5 V		3.3 V		
			V_{CCB}									
			5 V	1.8 V	1.8 V	1.8 V	2.5 V	5 V		3.3 V to 5 V		
			TYP	TYP	TYP	TYP	TYP	TYP	TYP			
C_{pdA}	A-port input, B-port output	$C_L = 0$, $f = 10 \text{ MHz}$, $t_r = t_f = 1 \text{ ns}$, $OE = V_{CCA}$ (outputs enabled)	5.9	5.7	5.9	5.9	6.7	6.9	8	pF		
	B-port input, A-port output		10.2	10.3	9.9	9.7	9.7	9.4	9.8			
C_{pdB}	A-port input, B-port output		29.9	22.2	21.5	20.8	21	23.4	23			
	B-port input, A-port output		22.9	16.7	16.7	16.8	17.8	20.8	20.9			
C_{pdA}	A-port input, B-port output		$C_L = 0$, $f = 10 \text{ MHz}$, $t_r = t_f = 1 \text{ ns}$, $OE = \text{GND}$ (outputs disabled)	0.01	0.01	0.01	0.01	0.01	0.01		0.01	pF
	B-port input, A-port output			0.06	0.01	0.01	0.01	0.01	0.01		0.01	
C_{pdB}	A-port input, B-port output	0.06		0.01	0.01	0.01	0.01	0.03	0.02			
	B-port input, A-port output	0.06		0.01	0.01	0.01	0.01	0.03	0.02			

6.17 Typical Characteristics

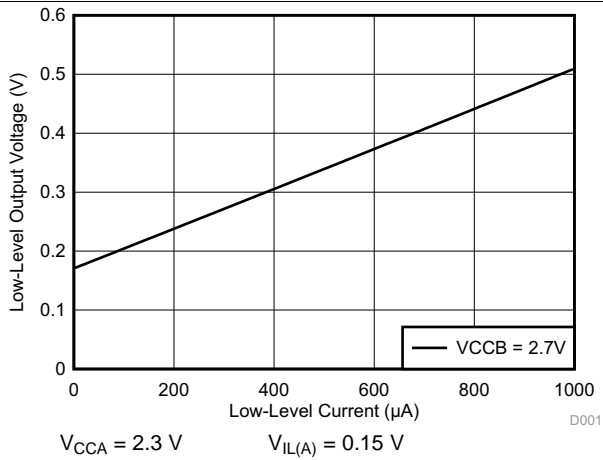

Figure 1. Low-Level Output Voltage ($V_{OL(Bx)}$) vs Low-Level Current ($I_{OL(Bx)}$)

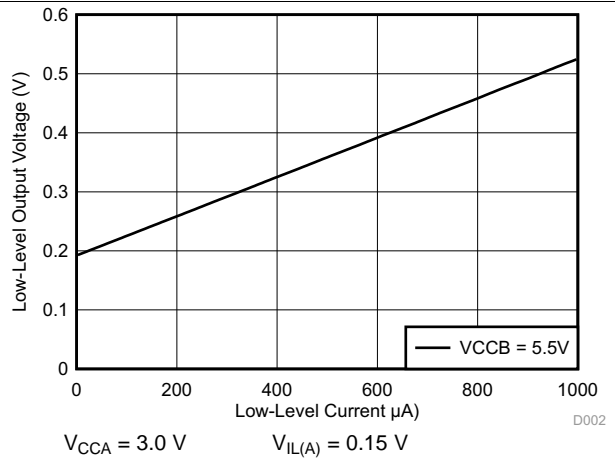

Figure 2. Low-Level Output Voltage ($V_{OL(Bx)}$) vs Low-Level Current ($I_{OL(Bx)}$)

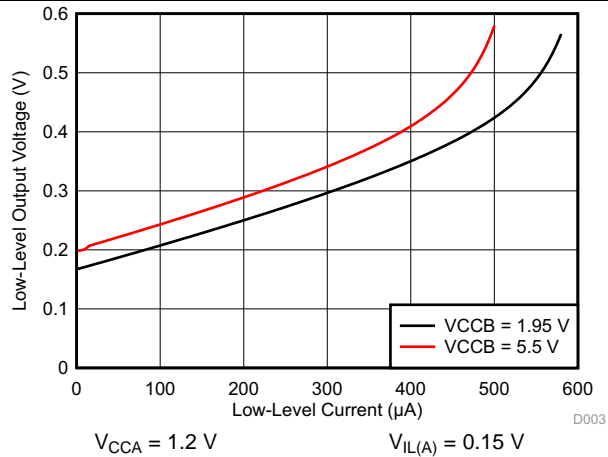

Figure 3. Low-Level Output Voltage ($V_{OL(Bx)}$) vs Low-Level Current ($I_{OL(Bx)}$)

7 Parameter Measurement Information

7.1 Load Circuits

Figure 4 shows the push-pull driver circuit used for measuring data rate, pulse duration, propagation delay, output rise-time and fall-time. Figure 5 shows the open-drain driver circuit used for measuring data rate, pulse duration, propagation delay, output rise-time and fall-time.

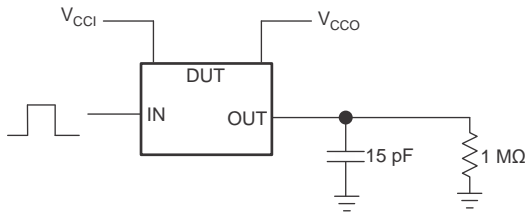

Figure 4. Data Rate, Pulse Duration, Propagation Delay, Output Rise-Time and Fall-Time Measurement Using a Push-Pull Driver

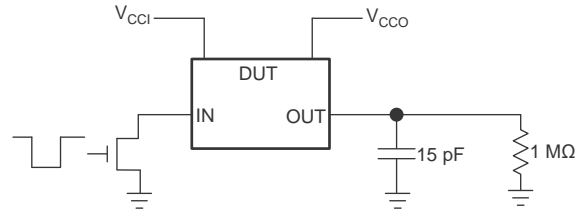
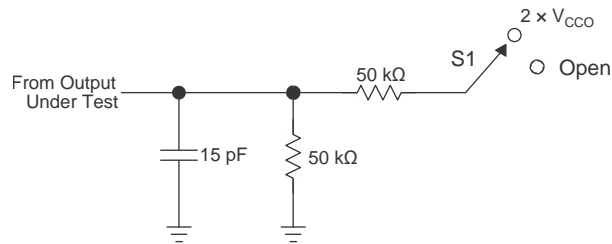

Figure 5. Data Rate (10 pF), Pulse Duration (10 pF), Propagation Delay, Output Rise-Time and Fall-Time Measurement Using an Open-Drain Driver



TEST	S1
t_{PZL} / t_{PLZ} (t_{dis})	$2 \times V_{CCO}$
t_{PHZ} / t_{PZH} (t_{en})	Open

Figure 6. Load Circuit for Enable-Time and Disable-Time Measurement

1. t_{PLZ} and t_{PHZ} are the same as t_{dis} .
2. t_{PZL} and t_{PZH} are the same as t_{en} .
3. V_{CCI} is the V_{CC} associated with the input port.
4. V_{CCO} is the V_{CC} associated with the output port.

7.2 Voltage Waveforms

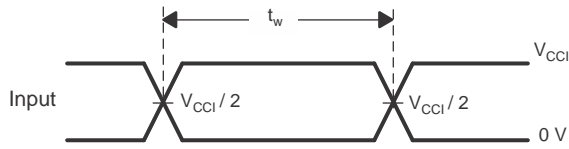

Figure 7. Pulse Duration (Push-Pull)

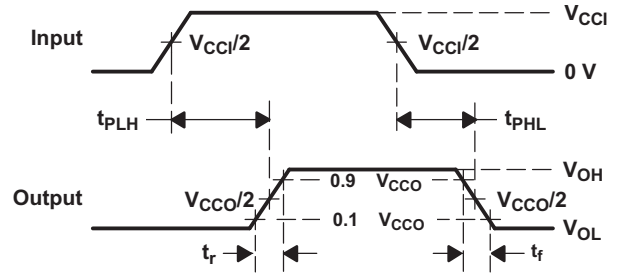

Figure 8. Propagation Delay Times

8 Detailed Description

8.1 Overview

The TXS0108E device is a directionless voltage-level translator specifically designed for translating logic voltage levels. The A-port accepts I/O voltages ranging from 1.2 V to 3.6 V. The B-port accepts I/O voltages from 1.65 V to 5.5 V. The device uses pass gate architecture with edge rate accelerators (one shots) to improve the overall data rate. The pull-up resistors, commonly used in open-drain applications, have been conveniently integrated so that an external resistor is not needed. While this device is designed for open-drain applications, the device can also translate push-pull CMOS logic outputs.

8.2 Functional Block Diagram

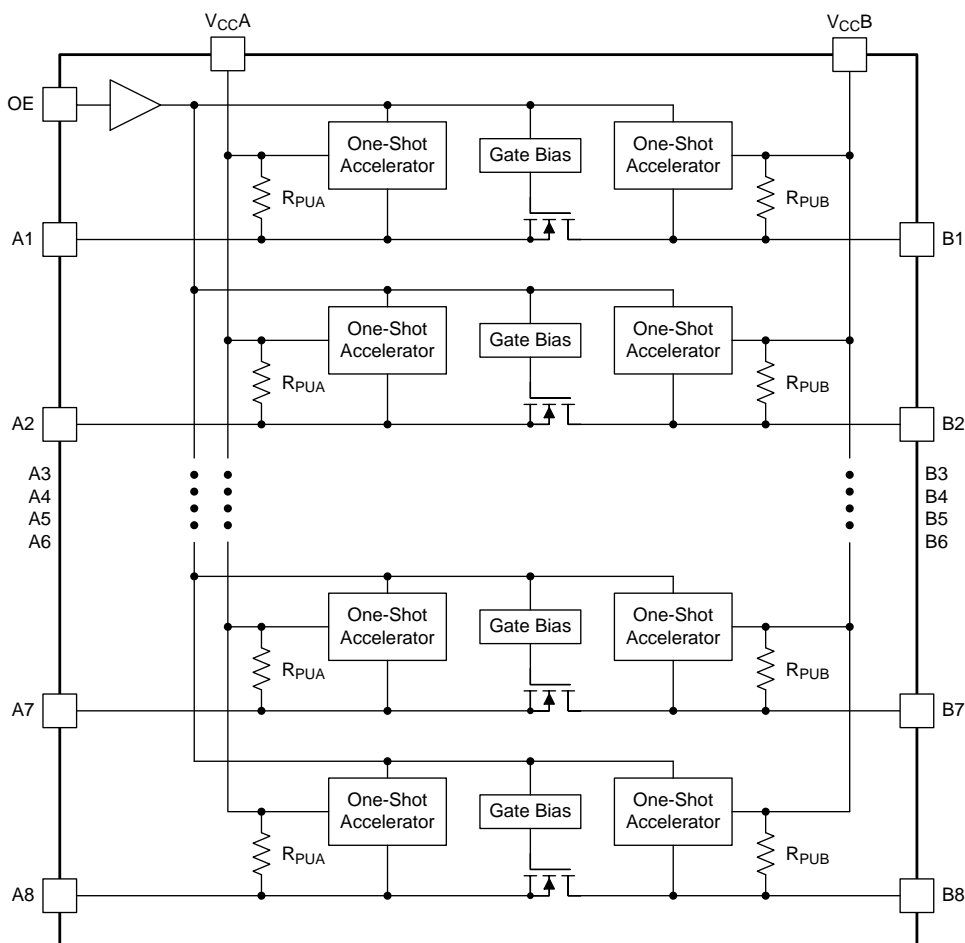

Each A-port I/O has a pull-up resistor (R_{PUA}) to V_{CCA} and each B-port I/O has a pull-up resistor (R_{PUB}) to V_{CCB} . R_{PUA} and R_{PUB} have a value of 40 k Ω when the output is driving low. R_{PUA} and R_{PUB} have a value of 4 k Ω when the output is driving high. R_{PUA} and R_{PUB} are disabled when OE = Low.

8.3 Feature Description

8.3.1 Architecture

Figure 9 describes semi-buffered architecture design this application requires for both push-pull and open-drain mode. This application uses edge-rate accelerator circuitry (for both the high-to-low and low-to-high edges), a high-on-resistance N-channel pass-gate transistor (on the order of 300 Ω to 500 Ω) and pull-up resistors (to provide DC-bias and drive capabilities) to meet these requirements. This design needs no direction-control signal (to control the direction of data flow from A to B or from B to A). The resulting implementation supports both low-speed open-drain operation as well as high-speed push-pull operation.

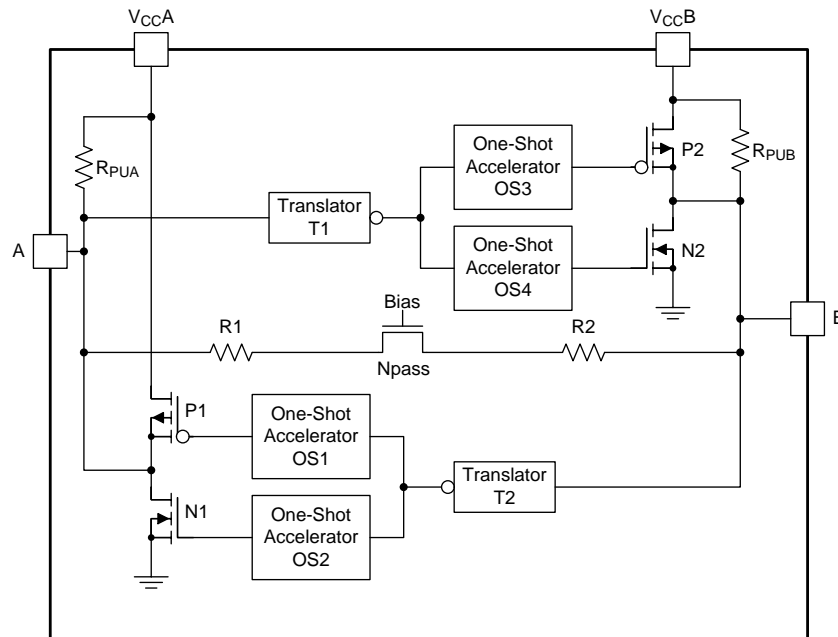
Feature Description (continued)

Figure 9. Architecture of a TXS0108E Cell

When transmitting data from A-ports to B-ports, during a rising edge the one-shot circuit (OS3) turns on the PMOS transistor (P2) for a short-duration which reduces the low-to-high transition time. Similarly, during a falling edge, when transmitting data from A to B, the one-shot circuit (OS4) turns on the N-channel MOSFET transistor (N2) for a short-duration which speeds up the high-to-low transition. The B-port edge-rate accelerator consists of one-shot circuits OS3 and OS4, transistors P2 and N2 and serves to rapidly force the B port high or low when a corresponding transition is detected on the A port.

When transmitting data from B- to A-ports, during a rising edge the one-shot circuit (OS1) turns on the PMOS transistor (P1) for a short-duration which reduces the low-to-high transition time. Similarly, during a falling edge, when transmitting data from B to A, the one-shot circuit (OS2) turns on NMOS transistor (N1) for a short-duration and this speeds up the high-to-low transition. The A-port edge-rate accelerator consists of one-shots OS1 and OS2, transistors P1 and N1 components and form the edge-rate accelerator and serves to rapidly force the A port high or low when a corresponding transition is detected on the B port.

8.3.2 Input Driver Requirements

The continuous DC-current *sinking* capability is determined by the external system-level open-drain (or push-pull) drivers that are interfaced to the TXS0108E I/O pins. Because the high bandwidth of these bidirectional I/O circuits is used to facilitate this fast change from an input to an output and an output to an input, they have a modest DC-current *sourcing* capability of hundreds of micro-amperes, as determined by the internal pull-up resistors.

The fall time (t_{fA} , t_{fB}) of a signal depends on the edge-rate and output impedance of the external device driving TXS0108E data I/Os, as well as the capacitive loading on the data lines.

Similarly, the t_{PHL} and maximum data rates also depend on the output impedance of the external driver. The values for t_{fA} , t_{fB} , t_{PHL} , and maximum data rates in the data sheet assume that the output impedance of the external driver is less than 50 Ω .

Feature Description (continued)

8.3.3 Output Load Considerations

TI recommends careful PCB layout practices with short PCB trace lengths to avoid excessive capacitive loading and to ensure that proper one-shot triggering takes place. PCB signal trace-lengths should be kept short enough such that the round trip delay of any reflection is less than the one-shot duration. This improves signal integrity by ensuring that any reflection sees a low impedance at the driver. The one-shot circuits have been designed to stay on for approximately 30 ns. The maximum capacitance of the lumped load that can be driven also depends directly on the one-shot duration. With very heavy capacitive loads, the one-shot can time-out before the signal is driven fully to the positive rail. The one-shot duration has been set to best optimize trade-offs between dynamic I_{CC} , load driving capability, and maximum bit-rate considerations. Both PCB trace length and connectors add to the capacitance of the TXS0108E output. Therefore, TI recommends that this lumped-load capacitance is considered in order to avoid one-shot retriggering, bus contention, output signal oscillations, or other adverse system-level affects.

8.3.4 Enable and Disable

The TXS0108E has an OE pin input that is used to disable the device by setting the OE pin low, which places all I/Os in the Hi-Z state. The disable time (t_{dis}) indicates the delay between the time when the OE pin goes low and when the outputs actually get disabled (Hi-Z). The enable time (t_{en}) indicates the amount of time the design must allow for the one-shot circuitry to become operational after the OE pin goes high.

8.3.5 Pull-up or Pull-down Resistors on I/O Lines

The TXS0108E has the smart pull-up resistors dynamically change value based on whether a low or a high is being passed through the I/O line. Each A-port I/O has a pull-up resistor (R_{PUA}) to V_{CCA} and each B-port I/O has a pull-up resistor (R_{PUB}) to V_{CCB} . R_{PUA} and R_{PUB} have a value of 40 k Ω when the output is driving low. R_{PUA} and R_{PUB} have a value of 4 k Ω when the output is driving high. R_{PUA} and R_{PUB} are disabled when OE = Low. This feature provides lower static power consumption (when the I/Os are passing a low), and supports lower V_{OL} values for the same size pass-gate transistor, and helps improve simultaneous switching performance.

8.4 Device Functional Modes

The TXS0108E device has two functional modes, enabled and disabled. To disable the device set the OE pin input low, which places all I/Os in a high impedance state. Setting the OE pin input high enables the device.

9 Application and Implementation

NOTE

Information in the following applications sections is not part of the TI component specification, and TI does not warrant its accuracy or completeness. TI's customers are responsible for determining suitability of components for their purposes. Customers should validate and test their design implementation to confirm system functionality.

9.1 Application Information

The TXS0108E can be used in level-translation applications for interfacing devices or systems operating at different interface voltages with one another. The device is ideal for use in applications where an open-drain driver is connected to the data I/Os. The device is appropriate for applications where a push-pull driver is connected to the data I/Os, but the TXB0104 device, (SCES650) *4-Bit Bidirectional Voltage-Level Translator* might be a better option for such push-pull applications. The device is a semi-buffered auto-direction-sensing voltage translator design is optimized for translation applications (for example, MMC Card Interfaces) that require the system to start out in a low-speed open-drain mode and then switch to a higher speed push-pull mode.

9.2 Typical Application

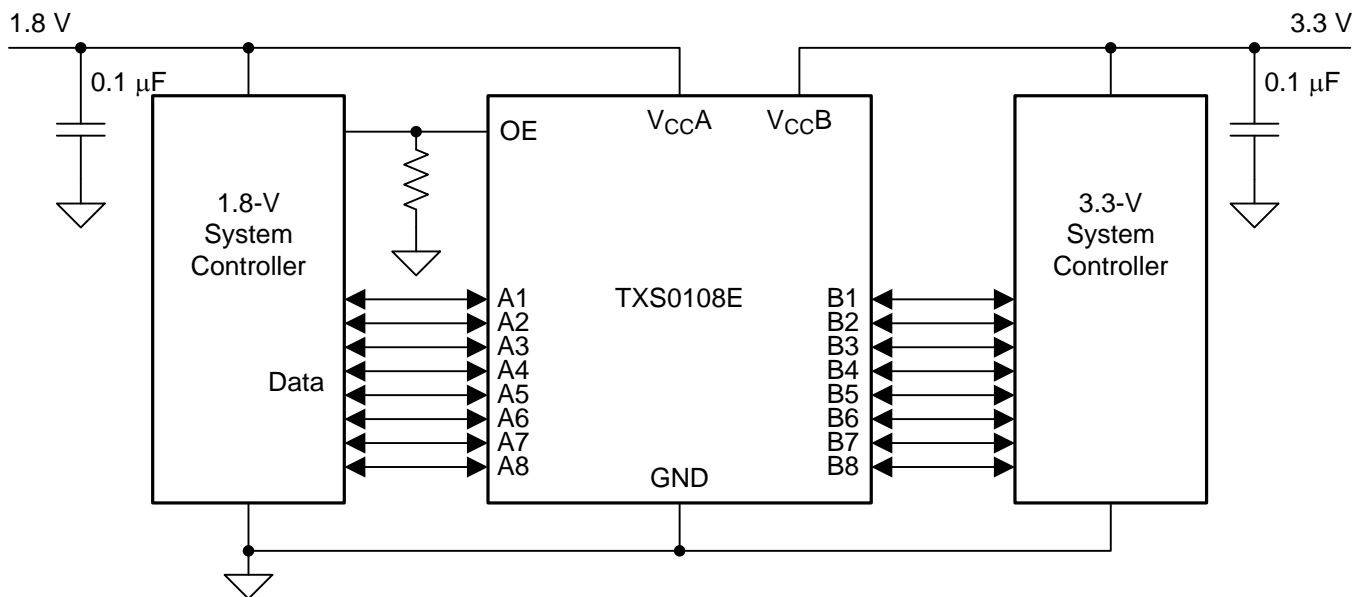

Figure 10. Typical Application Circuit

9.2.1 Design Requirements

For this design example, use the parameters listed in Table 1. Ensure that $V_{CCA} \leq V_{CCB}$.

Table 1. Design Parameters

DESIGN PARAMETER	EXAMPLE VALUE
Input voltage range	1.4 V to 3.6 V
Output voltage range	1.65 V to 5.5 V

9.2.2 Detailed Design Procedure

To begin the design process, determine the following:

- Input voltage range
 - Use the supply voltage of the device that is driving the TXS0108E device to determine the input voltage range. For a valid logic high the value must exceed the V_{IH} of the input port. For a valid logic low the value must be less than the V_{IL} of the input port.

- Output voltage range
 - Use the supply voltage of the device that the TXS0108E device is driving to determine the output voltage range.
 - The TXS0108E device has smart internal pull-up resistors. External pull-up resistors can be added to reduce the total RC of a signal trace if necessary.
- An external pull-down resistor decreases the output VOH and VOL. Use [Equation 1](#) to calculate the VOH as a result of an external pull-down resistor.

$$V_{OH} = V_{CCx} \times R_{PD} / (R_{PD} + 4 \text{ k}\Omega) \tag{1}$$

9.2.3 Application Curves

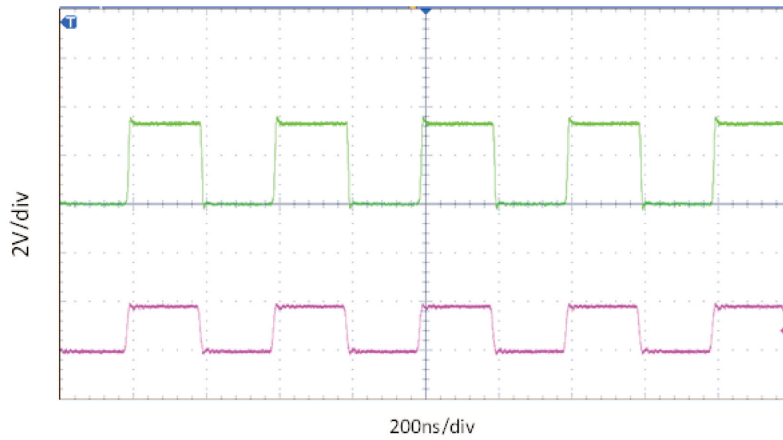

$V_{CCA} = 1.8 \text{ V}$

$V_{CCB} = 3.3 \text{ V}$

Figure 11. Level-Translation of a 2.5-MHz Signal

10 Power Supply Recommendations

During operation, ensure that $V_{CCA} \leq V_{CCB}$ at all times. The sequencing of each power supply will not damage the device during the power up operation, so either power supply can be ramped up first. The output-enable (OE) input circuit is designed so that it is supplied by V_{CCA} and when the (OE) input is low, all outputs are placed in the high-impedance state. To ensure the high-impedance state of the outputs during power up or power down, the OE input pin must be tied to GND through a pull-down resistor and must not be enabled until V_{CCA} and V_{CCB} are fully ramped and stable. The minimum value of the pull-down resistor to ground is determined by the current-sourcing capability of the driver.

11 Layout

11.1 Layout Guidelines

To ensure reliability of the device, following common printed-circuit board layout guidelines is recommended.

- Bypass capacitors should be used on power supplies. Place the capacitors as close as possible to the VCCA, VCCB pin and GND pin.
- Short trace lengths should be used to avoid excessive loading.
- PCB signal trace-lengths must be kept short enough so that the round-trip delay of any reflection is less than the one shot duration, approximately 30 ns, ensuring that any reflection encounters low impedance at the source driver.

11.2 Layout Example

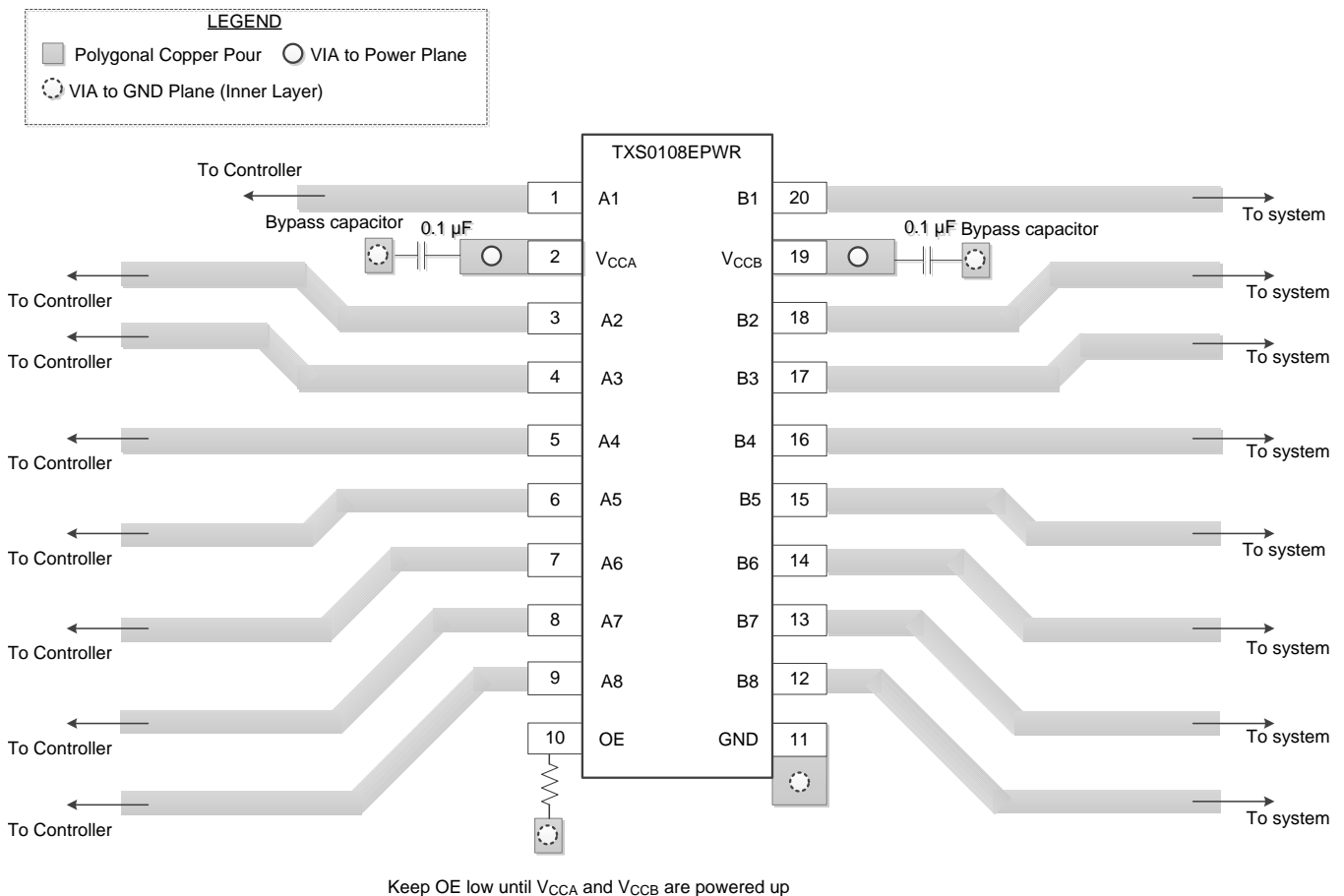

Figure 12. Layout Example

12 器件和文档支持

12.1 社区资源

The following links connect to TI community resources. Linked contents are provided "AS IS" by the respective contributors. They do not constitute TI specifications and do not necessarily reflect TI's views; see TI's [Terms of Use](#).

TI E2E™ Online Community *TI's Engineer-to-Engineer (E2E) Community*. Created to foster collaboration among engineers. At e2e.ti.com, you can ask questions, share knowledge, explore ideas and help solve problems with fellow engineers.

Design Support *TI's Design Support* Quickly find helpful E2E forums along with design support tools and contact information for technical support.

12.2 商标

E2E is a trademark of Texas Instruments.
All other trademarks are the property of their respective owners.

12.3 静电放电警告



这些装置包含有限的内置 ESD 保护。存储或装卸时，应将导线一起截短或将装置放置于导电泡棉中，以防止 MOS 门极遭受静电损伤。

12.4 Glossary

[SLYZ022](#) — *TI Glossary*.

This glossary lists and explains terms, acronyms, and definitions.

13 机械、封装和可订购信息

以下页中包括机械、封装和可订购信息。这些信息是针对指定器件可提供的最新数据。这些数据会在无通知且不对本文档进行修订的情况下发生改变。欲获得该数据表的浏览器版本，请查阅左侧的导航栏。

重要声明

德州仪器(TI)及其下属子公司有权根据 JESD46 最新标准,对所提供的产品和服务进行更正、修改、增强、改进或其它更改,并有权根据 JESD48 最新标准中止提供任何产品和服务。客户在下订单前应获取最新的相关信息,并验证这些信息是否完整且是最新的。所有产品的销售都遵循在订单确认时所提供的TI 销售条款与条件。

TI 保证其所销售的组件的性能符合产品销售时 TI 半导体产品销售条件与条款的适用规范。仅在 TI 保证的范围内,且 TI 认为有必要时才会使用测试或其它质量控制技术。除非适用法律做出了硬性规定,否则没有必要对每种组件的所有参数进行测试。

TI 对应用帮助或客户产品设计不承担任何义务。客户应对其使用 TI 组件的产品和应用自行负责。为尽量减小与客户产品和应用相关的风险,客户应提供充分的设计与操作安全措施。

TI 不对任何 TI 专利权、版权、屏蔽作品权或其它与使用了 TI 组件或服务的组合设备、机器或流程相关的 TI 知识产权中授予的直接或隐含权限作出任何保证或解释。TI 所发布的与第三方产品或服务有关的信息,不能构成从 TI 获得使用这些产品或服务的许可、授权、或认可。使用此类信息可能需要获得第三方的专利权或其它知识产权方面的许可,或是 TI 的专利权或其它知识产权方面的许可。

对于 TI 的产品手册或数据表中 TI 信息的重要部分,仅在没有对内容进行任何篡改且带有相关授权、条件、限制和声明的情况下才允许进行复制。TI 对此类篡改过的文件不承担任何责任或义务。复制第三方的信息可能需要服从额外的限制条件。

在转售 TI 组件或服务时,如果对该组件或服务参数的陈述与 TI 标明的参数相比存在差异或虚假成分,则会失去相关 TI 组件或服务的所有明示或暗示授权,且这是不正当的、欺诈性商业行为。TI 对任何此类虚假陈述均不承担任何责任或义务。

客户认可并同意,尽管任何应用相关信息或支持仍可能由 TI 提供,但他们将独立负责满足与其产品及其在应用中使用的 TI 产品相关的所有法律、法规和安全相关要求。客户声明并同意,他们具备制定与实施安全措施所需的全部专业技术和知识,可预见故障的危险后果、监测故障及其后果、降低有可能造成人身伤害的故障的发生机率并采取适当的补救措施。客户将全额赔偿因在此类安全关键应用中使用任何 TI 组件而对 TI 及其代理造成的任何损失。

在某些场合中,为了推进安全相关应用有可能对 TI 组件进行特别的促销。TI 的目标是利用此类组件帮助客户设计和创立其特有的可满足适用的功能安全性标准和要求的终端产品解决方案。尽管如此,此类组件仍然服从这些条款。

TI 组件未获得用于 FDA Class III (或类似的生命攸关医疗设备)的授权许可,除非各方授权官员已经达成了专门管控此类使用的特别协议。

只有那些 TI 特别注明属于军用等级或“增强型塑料”的 TI 组件才是设计或专门用于军事/航空应用或环境的。购买者认可并同意,对并非指定面向军事或航空航天用途的 TI 组件进行军事或航空航天方面的应用,其风险由客户单独承担,并且由客户独立负责满足与此类使用相关的所有法律和法规要求。

TI 已明确指定符合 ISO/TS16949 要求的产品,这些产品主要用于汽车。在任何情况下,因使用非指定产品而无法达到 ISO/TS16949 要求, TI 不承担任何责任。

	产品		应用
数字音频	www.ti.com.cn/audio	通信与电信	www.ti.com.cn/telecom
放大器和线性器件	www.ti.com.cn/amplifiers	计算机及周边	www.ti.com.cn/computer
数据转换器	www.ti.com.cn/dataconverters	消费电子	www.ti.com.cn/consumer-apps
DLP® 产品	www.dlp.com	能源	www.ti.com.cn/energy
DSP - 数字信号处理器	www.ti.com.cn/dsp	工业应用	www.ti.com.cn/industrial
时钟和计时器	www.ti.com.cn/clockandtimers	医疗电子	www.ti.com.cn/medical
接口	www.ti.com.cn/interface	安防应用	www.ti.com.cn/security
逻辑	www.ti.com.cn/logic	汽车电子	www.ti.com.cn/automotive
电源管理	www.ti.com.cn/power	视频和影像	www.ti.com.cn/video
微控制器 (MCU)	www.ti.com.cn/microcontrollers		
RFID 系统	www.ti.com.cn/rfidsys		
OMAP应用处理器	www.ti.com/omap		
无线连通性	www.ti.com.cn/wirelessconnectivity	德州仪器在线技术支持社区	www.deyisupport.com

邮寄地址: 上海市浦东新区世纪大道1568号, 中建大厦32楼邮政编码: 200122
Copyright © 2016, 德州仪器半导体技术(上海)有限公司

PACKAGING INFORMATION

Orderable Device	Status (1)	Package Type	Package Drawing	Pins	Package Qty	Eco Plan (2)	Lead/Ball Finish (6)	MSL Peak Temp (3)	Op Temp (°C)	Device Marking (4/5)	Samples
TXS0108EPWR	ACTIVE	TSSOP	PW	20	2000	Green (RoHS & no Sb/Br)	CU NIPDAU	Level-1-260C-UNLIM	-40 to 85	YF08E	Samples
TXS0108EPWRG4	ACTIVE	TSSOP	PW	20	2000	Green (RoHS & no Sb/Br)	CU NIPDAU	Level-1-260C-UNLIM	-40 to 85	YF08E	Samples
TXS0108ERGYR	ACTIVE	VQFN	RGY	20	3000	Green (RoHS & no Sb/Br)	CU NIPDAU	Level-2-260C-1 YEAR	-40 to 85	YF08E	Samples
TXS0108EZXYR	ACTIVE	BGA MICROSTAR JUNIOR	ZXY	20	2500	Green (RoHS & no Sb/Br)	SNAGCU	Level-1-260C-UNLIM	-40 to 85	YF08E	Samples

(1) The marketing status values are defined as follows:

ACTIVE: Product device recommended for new designs.

LIFEBUY: TI has announced that the device will be discontinued, and a lifetime-buy period is in effect.

NRND: Not recommended for new designs. Device is in production to support existing customers, but TI does not recommend using this part in a new design.

PREVIEW: Device has been announced but is not in production. Samples may or may not be available.

OBSOLETE: TI has discontinued the production of the device.

(2) Eco Plan - The planned eco-friendly classification: Pb-Free (RoHS), Pb-Free (RoHS Exempt), or Green (RoHS & no Sb/Br) - please check <http://www.ti.com/productcontent> for the latest availability information and additional product content details.

TBD: The Pb-Free/Green conversion plan has not been defined.

Pb-Free (RoHS): TI's terms "Lead-Free" or "Pb-Free" mean semiconductor products that are compatible with the current RoHS requirements for all 6 substances, including the requirement that lead not exceed 0.1% by weight in homogeneous materials. Where designed to be soldered at high temperatures, TI Pb-Free products are suitable for use in specified lead-free processes.

Pb-Free (RoHS Exempt): This component has a RoHS exemption for either 1) lead-based flip-chip solder bumps used between the die and package, or 2) lead-based die adhesive used between the die and leadframe. The component is otherwise considered Pb-Free (RoHS compatible) as defined above.

Green (RoHS & no Sb/Br): TI defines "Green" to mean Pb-Free (RoHS compatible), and free of Bromine (Br) and Antimony (Sb) based flame retardants (Br or Sb do not exceed 0.1% by weight in homogeneous material)

(3) MSL, Peak Temp. - The Moisture Sensitivity Level rating according to the JEDEC industry standard classifications, and peak solder temperature.

(4) There may be additional marking, which relates to the logo, the lot trace code information, or the environmental category on the device.

(5) Multiple Device Markings will be inside parentheses. Only one Device Marking contained in parentheses and separated by a "~" will appear on a device. If a line is indented then it is a continuation of the previous line and the two combined represent the entire Device Marking for that device.

(6) Lead/Ball Finish - Orderable Devices may have multiple material finish options. Finish options are separated by a vertical ruled line. Lead/Ball Finish values may wrap to two lines if the finish value exceeds the maximum column width.

Important Information and Disclaimer: The information provided on this page represents TI's knowledge and belief as of the date that it is provided. TI bases its knowledge and belief on information provided by third parties, and makes no representation or warranty as to the accuracy of such information. Efforts are underway to better integrate information from third parties. TI has taken and continues to take reasonable steps to provide representative and accurate information but may not have conducted destructive testing or chemical analysis on incoming materials and chemicals. TI and TI suppliers consider certain information to be proprietary, and thus CAS numbers and other limited information may not be available for release.

In no event shall TI's liability arising out of such information exceed the total purchase price of the TI part(s) at issue in this document sold by TI to Customer on an annual basis.

OTHER QUALIFIED VERSIONS OF TXS0108E :

- Automotive: [TXS0108E-Q1](#)

NOTE: Qualified Version Definitions:

- Automotive - Q100 devices qualified for high-reliability automotive applications targeting zero defects

TAPE AND REEL INFORMATION



QUADRANT ASSIGNMENTS FOR PIN 1 ORIENTATION IN TAPE



*All dimensions are nominal

Device	Package Type	Package Drawing	Pins	SPQ	Reel Diameter (mm)	Reel Width W1 (mm)	A0 (mm)	B0 (mm)	K0 (mm)	P1 (mm)	W (mm)	Pin1 Quadrant
TXS0108EPWR	TSSOP	PW	20	2000	330.0	16.4	6.95	7.1	1.6	8.0	16.0	Q1
TXS0108ERGYR	VQFN	RGY	20	3000	330.0	12.4	3.8	4.8	1.6	8.0	12.0	Q1
TXS0108EZXYR	BGA MICROSTAR JUNIOR	ZXY	20	2500	330.0	12.4	2.8	3.3	1.0	4.0	12.0	Q2

TAPE AND REEL BOX DIMENSIONS

*All dimensions are nominal

Device	Package Type	Package Drawing	Pins	SPQ	Length (mm)	Width (mm)	Height (mm)
TXS0108EPWR	TSSOP	PW	20	2000	367.0	367.0	38.0
TXS0108ERGYR	VQFN	RGY	20	3000	367.0	367.0	35.0
TXS0108EZXYR	BGA MICROSTAR JUNIOR	ZXY	20	2500	336.6	336.6	28.6

EXAMPLE BOARD LAYOUT

ZXY0020A

VFBGA - 0.61 mm max height

PLASTIC BALL GRID ARRAY

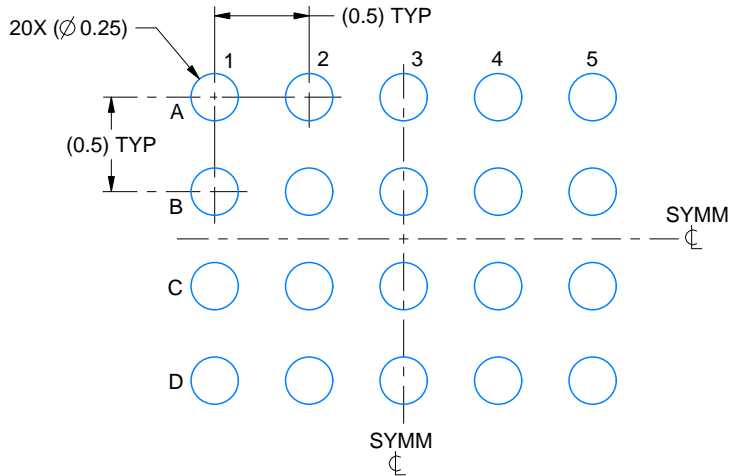

LAND PATTERN EXAMPLE
EXPOSED METAL SHOWN
SCALE:25X

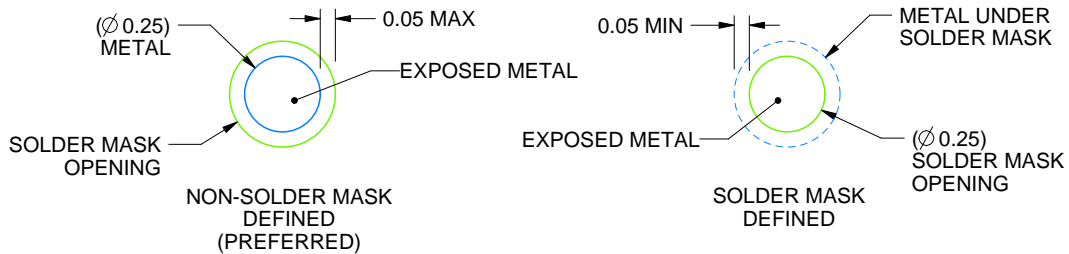

SOLDER MASK DETAILS
NOT TO SCALE

4222996/A 12/2016

NOTES: (continued)

- Final dimensions may vary due to manufacturing tolerance considerations and also routing constraints. For information, see Texas Instruments literature number SPRAA99 (www.ti.com/lit/spraa99).

EXAMPLE STENCIL DESIGN

ZXY0020A

VFBGA - 0.61 mm max height

PLASTIC BALL GRID ARRAY

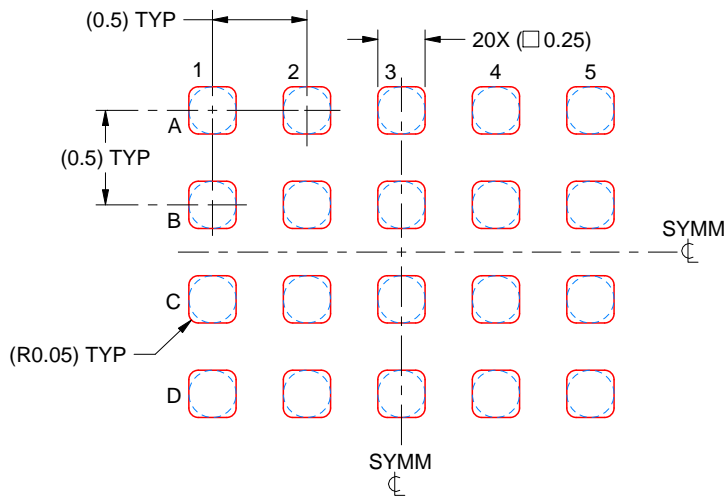

SOLDER PASTE EXAMPLE
BASED ON 0.1 mm THICK STENCIL
SCALE: 25X

4222996/A 12/2016

NOTES: (continued)

4. Laser cutting apertures with trapezoidal walls and rounded corners may offer better paste release.

RGY (R-PVQFN-N20)

PLASTIC QUAD FLATPACK NO-LEAD

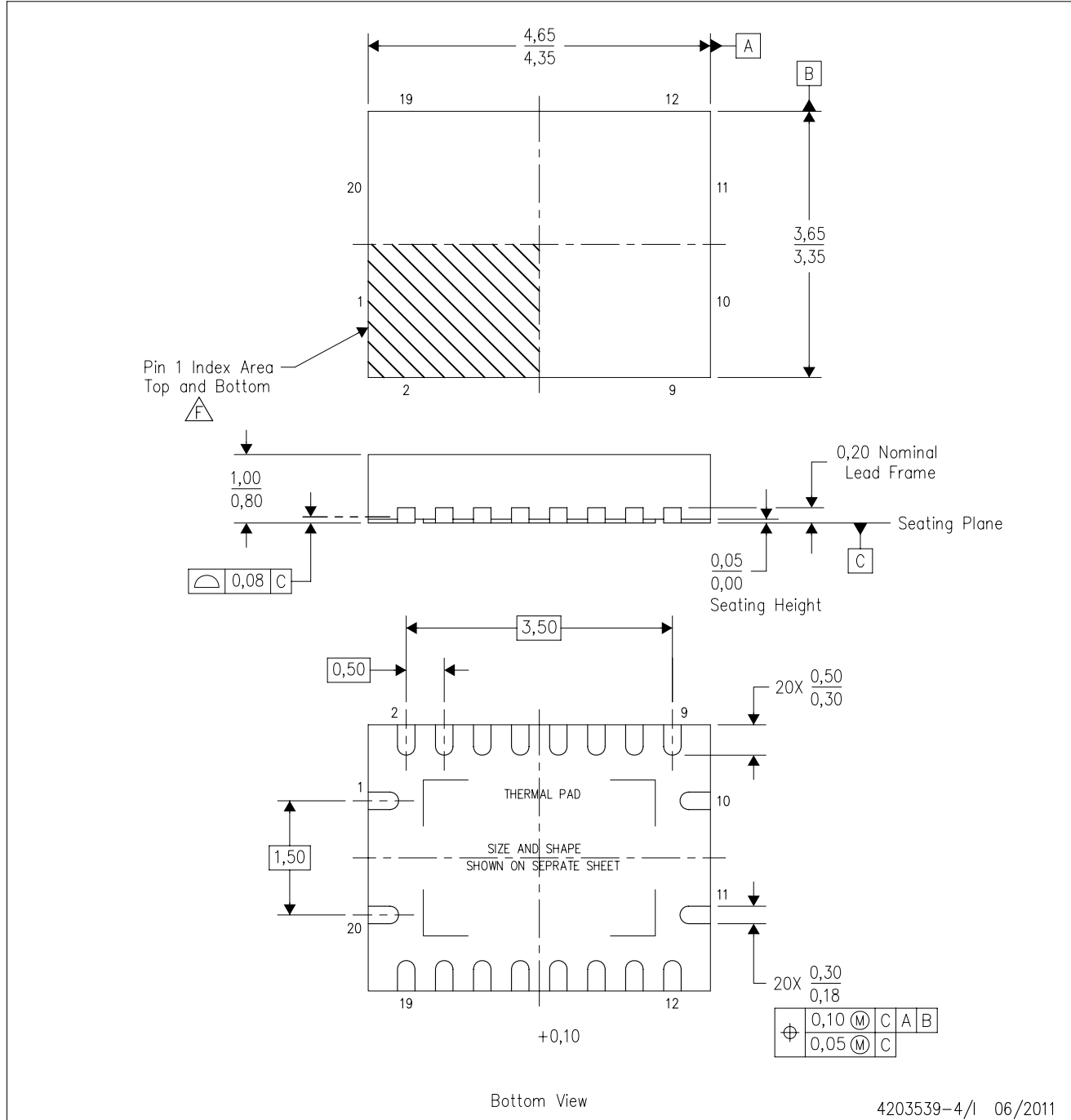

- NOTES:
- All linear dimensions are in millimeters. Dimensioning and tolerancing per ASME Y14.5M-1994.
 - This drawing is subject to change without notice.
 - QFN (Quad Flatpack No-Lead) package configuration.
 - The package thermal pad must be soldered to the board for thermal and mechanical performance.
 - See the additional figure in the Product Data Sheet for details regarding the exposed thermal pad features and dimensions.
 - △ Pin 1 identifiers are located on both top and bottom of the package and within the zone indicated. The Pin 1 identifiers are either a molded, marked, or metal feature.
 - Package complies to JEDEC MO-241 variation BA.

RGY (R-PVQFN-N20)

PLASTIC QUAD FLATPACK NO-LEAD

THERMAL INFORMATION

This package incorporates an exposed thermal pad that is designed to be attached directly to an external heatsink. The thermal pad must be soldered directly to the printed circuit board (PCB). After soldering, the PCB can be used as a heatsink. In addition, through the use of thermal vias, the thermal pad can be attached directly to the appropriate copper plane shown in the electrical schematic for the device, or alternatively, can be attached to a special heatsink structure designed into the PCB. This design optimizes the heat transfer from the integrated circuit (IC).

For information on the Quad Flatpack No-Lead (QFN) package and its advantages, refer to Application Report, QFN/SON PCB Attachment, Texas Instruments Literature No. SLUA271. This document is available at www.ti.com.

The exposed thermal pad dimensions for this package are shown in the following illustration.

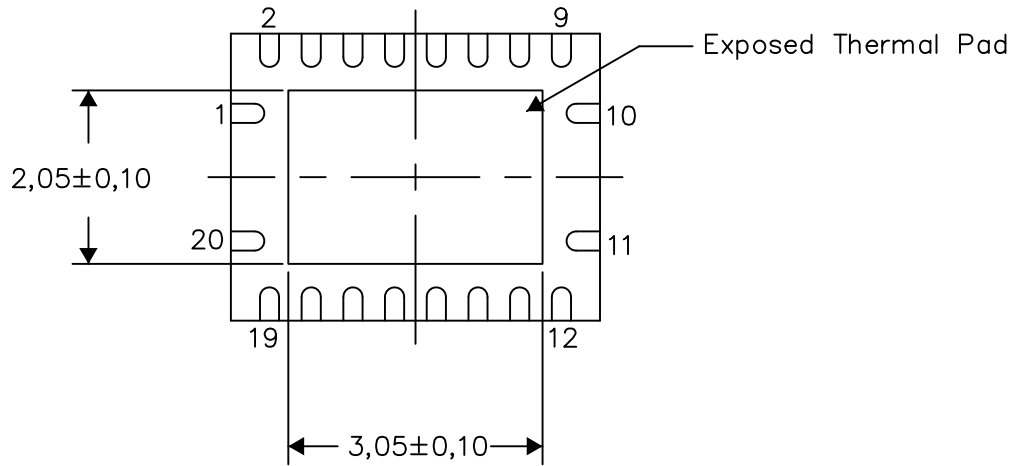

Bottom View

Exposed Thermal Pad Dimensions

4206353-4/P 03/14

NOTE: All linear dimensions are in millimeters

RGY (R-PVQFN-N20)

PLASTIC QUAD FLATPACK NO-LEAD

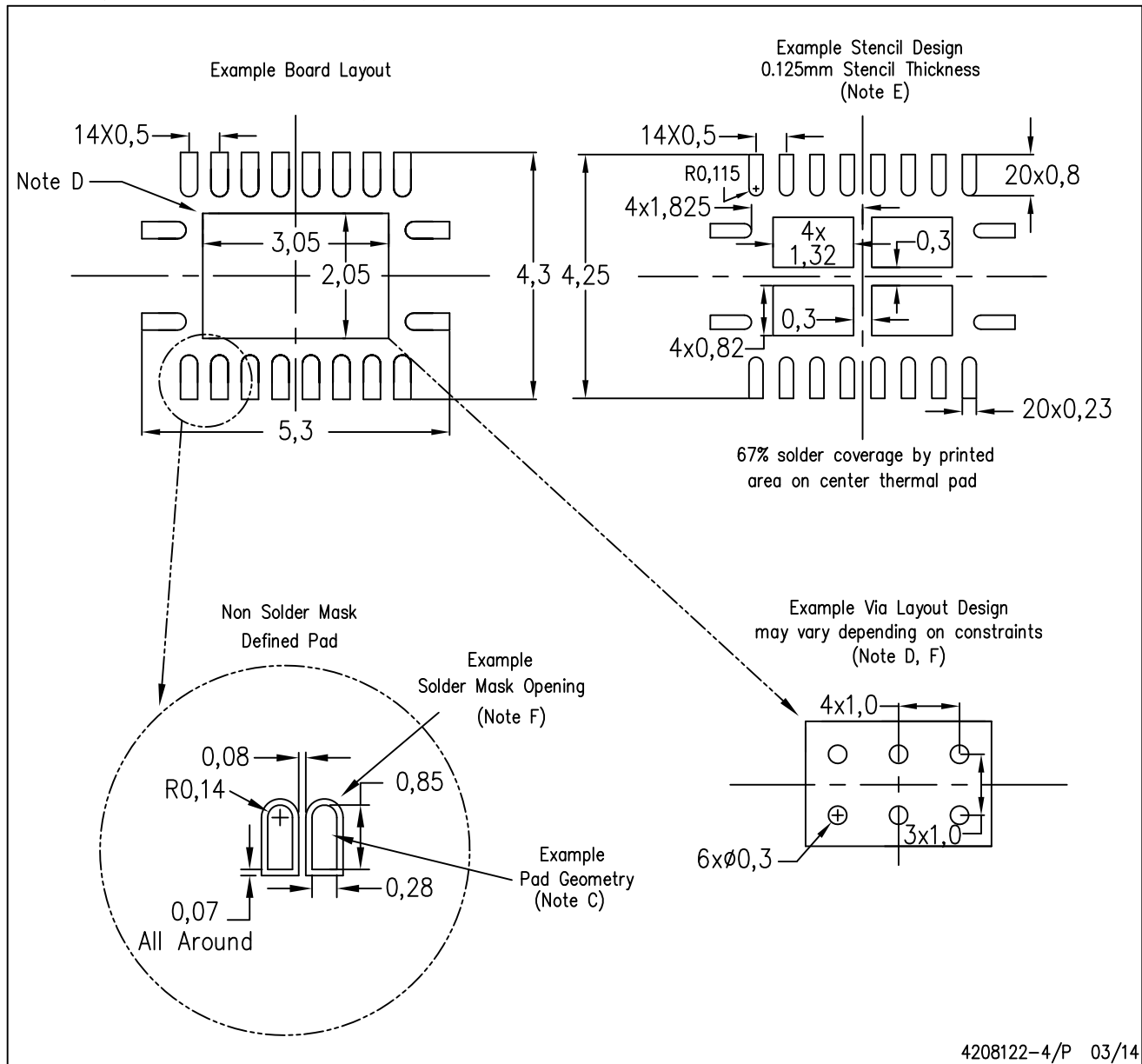

- NOTES:
- A. All linear dimensions are in millimeters.
 - B. This drawing is subject to change without notice.
 - C. Publication IPC-7351 is recommended for alternate designs.
 - D. This package is designed to be soldered to a thermal pad on the board. Refer to Application Note, Quad Flat-Pack QFN/SON PCB Attachment, Texas Instruments Literature No. SLUA271, and also the Product Data Sheets for specific thermal information, via requirements, and recommended board layout. These documents are available at www.ti.com <<http://www.ti.com>>.
 - E. Laser cutting apertures with trapezoidal walls and also rounding corners will offer better paste release. Customers should contact their board assembly site for stencil design recommendations. Refer to IPC 7525 for stencil design considerations.
 - F. Customers should contact their board fabrication site for minimum solder mask web tolerances between signal pads.

PW (R-PDSO-G20)

PLASTIC SMALL OUTLINE

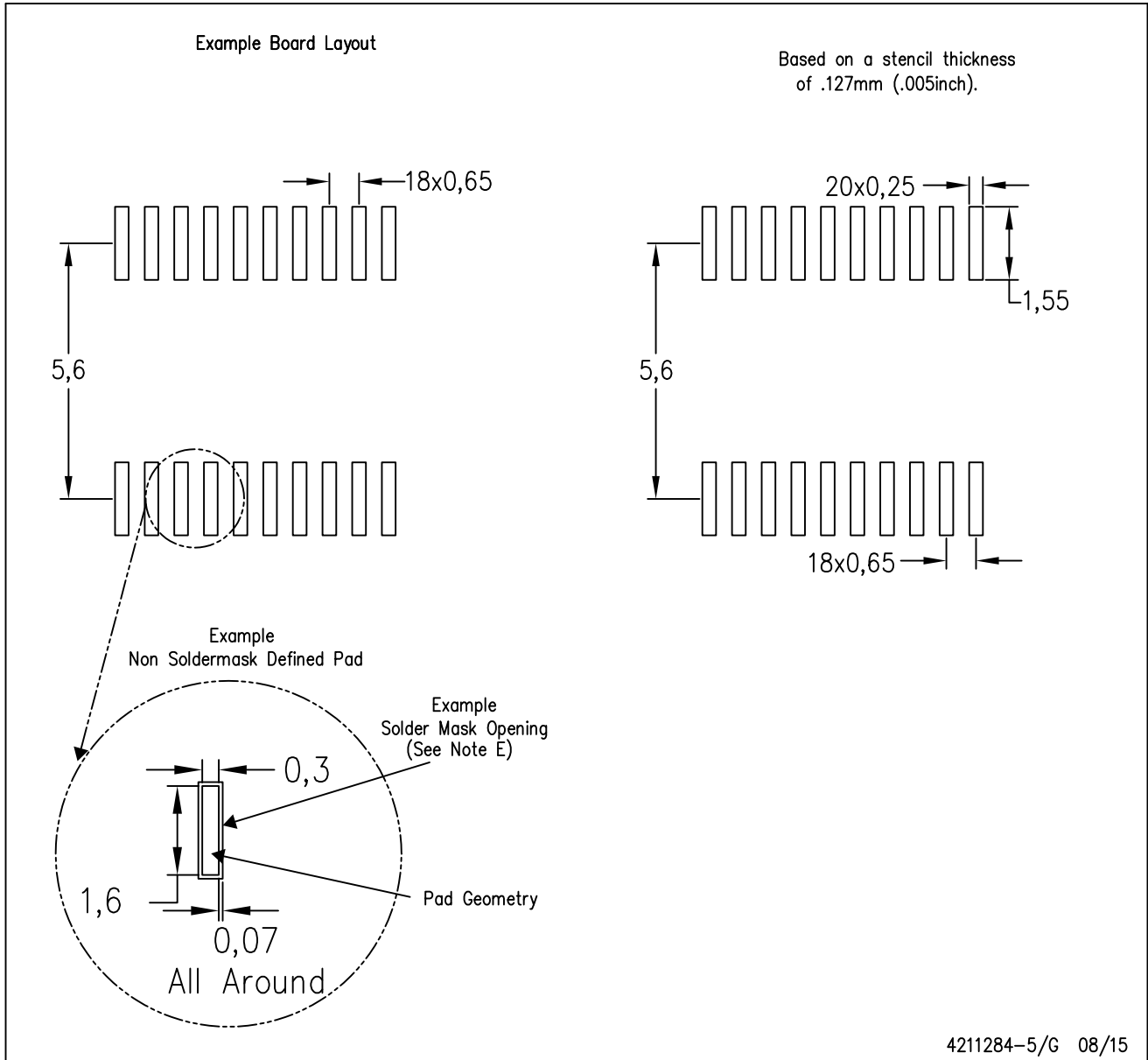

- NOTES:
- A. All linear dimensions are in millimeters.
 - B. This drawing is subject to change without notice.
 - C. Publication IPC-7351 is recommended for alternate design.
 - D. Laser cutting apertures with trapezoidal walls and also rounding corners will offer better paste release. Customers should contact their board assembly site for stencil design recommendations. Refer to IPC-7525 for other stencil recommendations.
 - E. Customers should contact their board fabrication site for solder mask tolerances between and around signal pads.

重要声明

德州仪器(TI) 及其下属子公司有权根据 JESD46 最新标准, 对所提供的产品和服务进行更正、修改、增强、改进或其它更改, 并有权根据 JESD48 最新标准中止提供任何产品和服务。客户在下订单前应获取最新的相关信息, 并验证这些信息是否完整且是最新的。所有产品的销售都遵循在订单确认时所提供的TI 销售条款与条件。

TI 保证其所销售的组件的性能符合产品销售时 TI 半导体产品销售条件与条款的适用规范。仅在 TI 保证的范围内, 且 TI 认为有必要时才会使用测试或其它质量控制技术。除非适用法律做出了硬性规定, 否则没有必要对每种组件的所有参数进行测试。

TI 对应用帮助或客户产品设计不承担任何义务。客户应对其使用 TI 组件的产品和应用自行负责。为尽量减小与客户产品和应用相关的风险, 客户应提供充分的设计与操作安全措施。

TI 不对任何 TI 专利权、版权、屏蔽作品权或其它与使用了 TI 组件或服务的组合设备、机器或流程相关的 TI 知识产权中授予的直接或间接权利作出任何保证或解释。TI 所发布的与第三方产品或服务有关的信息, 不能构成从 TI 获得使用这些产品或服务的许可、授权、或认可。使用此类信息可能需要获得第三方的专利权或其它知识产权方面的许可, 或是 TI 的专利权或其它知识产权方面的许可。

对于 TI 的产品手册或数据表中 TI 信息的重要部分, 仅在没有对内容进行任何篡改且带有相关授权、条件、限制和声明的情况下才允许进行复制。TI 对此类篡改过的文件不承担任何责任或义务。复制第三方的信息可能需要服从额外的限制条件。

在转售 TI 组件或服务时, 如果对该组件或服务参数的陈述与 TI 标明的参数相比存在差异或虚假成分, 则会失去相关 TI 组件或服务的所有明示或暗示授权, 且这是不正当的、欺诈性商业行为。TI 对任何此类虚假陈述均不承担任何责任或义务。

客户认可并同意, 尽管任何应用相关信息或支持仍可能由 TI 提供, 但他们将独自负责满足与其产品及其应用中使用 TI 产品相关的所有法律、法规和安全相关要求。客户声明并同意, 他们具备制定与实施安全措施所需的全部专业技术和知识, 可预见故障的危险后果、监测故障及其后果、降低有可能造成人身伤害的故障的发生机率并采取适当的补救措施。客户将全额赔偿因在此类安全关键应用中使用任何 TI 组件而对 TI 及其代理造成的任何损失。

在某些场合中, 为了推进安全相关应用有可能对 TI 组件进行特别的促销。TI 的目标是利用此类组件帮助客户设计和创立其特有的可满足适用的功能安全性标准和要求的终端产品解决方案。尽管如此, 此类组件仍然服从这些条款。

TI 组件未获得用于 FDA Class III (或类似的生命攸关医疗设备) 的授权许可, 除非各方授权官员已经达成了专门管控此类使用的特别协议。

只有那些 TI 特别注明属于军用等级或“增强型塑料”的 TI 组件才是设计或专门用于军事/航空应用或环境的。购买者认可并同意, 对并非指定面向军事或航空航天用途的 TI 组件进行军事或航空航天方面的应用, 其风险由客户单独承担, 并且由客户独自负责满足与此类使用相关的所有法律和法规要求。

TI 已明确指定符合 ISO/TS16949 要求的产品, 这些产品主要用于汽车。在任何情况下, 因使用非指定产品而无法达到 ISO/TS16949 要求, TI 不承担任何责任。

	产品		应用
数字音频	www.ti.com.cn/audio	通信与电信	www.ti.com.cn/telecom
放大器和线性器件	www.ti.com.cn/amplifiers	计算机及周边	www.ti.com.cn/computer
数据转换器	www.ti.com.cn/dataconverters	消费电子	www.ti.com.cn/consumer-apps
DLP® 产品	www.dlp.com	能源	www.ti.com.cn/energy
DSP - 数字信号处理器	www.ti.com.cn/dsp	工业应用	www.ti.com.cn/industrial
时钟和计时器	www.ti.com.cn/clockandtimers	医疗电子	www.ti.com.cn/medical
接口	www.ti.com.cn/interface	安防应用	www.ti.com.cn/security
逻辑	www.ti.com.cn/logic	汽车电子	www.ti.com.cn/automotive
电源管理	www.ti.com.cn/power	视频和影像	www.ti.com.cn/video
微控制器 (MCU)	www.ti.com.cn/microcontrollers		
RFID 系统	www.ti.com.cn/rfidsys		
OMAP应用处理器	www.ti.com.cn/omap		
无线连通性	www.ti.com.cn/wirelessconnectivity	德州仪器在线技术支持社区	www.deyisupport.com

Mailing Address: Texas Instruments, Post Office Box 655303, Dallas, Texas 75265
Copyright © 2016, Texas Instruments Incorporated