

DUAL-CHANNEL 10-Ω SPST ANALOG SWITCH

Check for Samples: [TS5A2066](#)

FEATURES

- Low ON-State Resistance (10 Ω)
- Control Inputs Are 5-V Tolerant
- Low Charge Injection
- Excellent ON-State Resistance Matching
- Low Total Harmonic Distortion (THD)
- 1.65-V to 5.5-V Single-Supply Operation
- Latch-Up Performance Exceeds 100 mA Per JESD 78, Class II
- ESD Performance Tested Per JESD 22
 - 2000-V Human-Body Model (A114-B, Class II)
 - 1000-V Charged-Device Model (C101)

APPLICATIONS

- Sample-and-Hold Circuits
- Battery-Powered Equipment
- Audio and Video Signal Routing
- Communication Circuits
- Cell Phones
- Low-Voltage Data-Acquisition Systems
- PDAs

DESCRIPTION/ORDERING INFORMATION

The TS5A2066 is a dual single-pole single-throw (SPST) analog switch that is designed to operate from 1.65 V to 5.5 V. This device can handle both digital and analog signals, and signals up to V_+ can be transmitted in either direction.

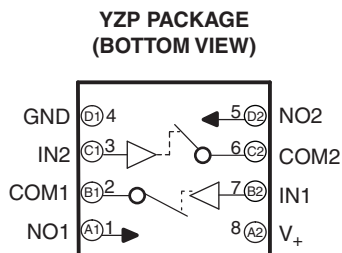
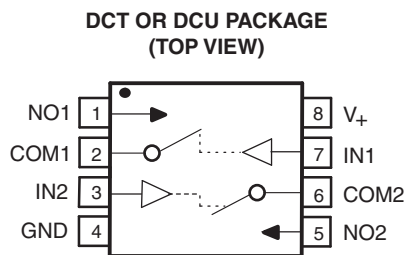
Table 1. Summary of Characteristics⁽¹⁾

Configuration	Dual Single Pole Single Throw (2 × SPST)
Number of channels	2
ON-state resistance (r_{on})	7.5 Ω
ON-state resistance match (Δr_{on})	0.4 Ω
ON-state resistance flatness ($r_{on(flat)}$)	3.5 Ω
Turn-on/turn-off time (t_{ON}/t_{OFF})	5.8 ns/3.6 ns
Charge injection (Q_C)	1 pC
Bandwidth (BW)	400 MHz
OFF isolation (O_{ISO})	−68 dB
Crosstalk (X_{TALK})	−66 dB
Total harmonic distortion (THD)	0.01%
Leakage current ($I_{COM(OFF)}/I_{NC(OFF)}$)	±50 nA
Power-supply current (I_+)	0.1 μA
Package options	8-pin DSBGA, SSOP, or VSSOP

⁽¹⁾ $V_+ = 5\text{ V}$ and $T_A = 25^\circ\text{C}$

Please be aware that an important notice concerning availability, standard warranty, and use in critical applications of Texas Instruments semiconductor products and disclaimers thereto appears at the end of this data sheet.

NanoFree is a trademark of Texas Instruments.

ORDERING INFORMATION⁽¹⁾

T _A	PACKAGE ⁽²⁾		ORDERABLE PART NUMBER	TOP-SIDE MARKING ⁽³⁾
-40°C to 85°C	NanoFree™ – WCSP (DSBGA) 0.23-mm Large Bump – YZP (Pb-free)	Reel of 3000	TS5A2066YZPR	___J4_
	SSOP – DCT	Reel of 3000	TS5A2066DCTR	JAG___
	VSSOP – DCU	Reel of 3000	TS5A2066DCUR	JAG_

- (1) For the most current package and ordering information, see the Package Option Addendum at the end of this document, or see the TI web site at www.ti.com.
- (2) Package drawings, thermal data, and symbolization are available at www.ti.com/packaging.
- (3) DCT: The actual top-side marking has three additional characters that designate the year, month, and wafer fab/assembly site.
DCU: The actual top-side marking has one additional character that designates the wafer fab/assembly site.
YZP: The actual top-side marking has three preceding characters to denote year, month, and sequence code, and one following character to designate the wafer fab/assembly site. Pin 1 identifier indicates solder-bump composition (1 = SnPb, ● = Pb-free).

FUNCTION TABLE

IN	NO TO COM, COM TO NO
L	OFF
H	ON

Absolute Minimum and Maximum Ratings^{(1) (2)}

over operating free-air temperature range (unless otherwise noted)

		MIN	MAX	UNIT
V ₊	Supply voltage range ⁽³⁾	-0.5	6.5	V
V _{NO} V _{COM}	Analog voltage range ^{(3) (4) (5)}	-0.5	V ₊ + 0.5	V
I _K	Analog port diode current	V _{NO} , V _{COM} < 0 or V _{NO} , V _{COM} > V ₊		mA
I _{NO} I _{COM}	On-state switch current	V _{NO} , V _{COM} = 0 to V ₊		mA
V _I	Digital input voltage range ^{(3) (4)}	-0.5	6.5	V
I _{IK}	Digital input clamp current	V _I < 0		mA
I ₊	Continuous current through V ₊		100	mA
I _{GND}	Continuous current through GND	-100	100	mA
θ _{JA}	Package thermal impedance ⁽⁶⁾	DCT package		°C/W
		DCU package		
		YZP package		
T _{stg}	Storage temperature range	-65	150	°C

- (1) Stresses beyond those listed under "absolute maximum ratings" may cause permanent damage to the device. These are stress ratings only, and functional operation of the device at these or any other conditions beyond those indicated under "recommended operating conditions" is not implied. Exposure to absolute-maximum-rated conditions for extended periods may affect device reliability.
- (2) The algebraic convention, whereby the most negative value is a minimum and the most positive value is a maximum
- (3) All voltages are with respect to ground, unless otherwise specified.
- (4) The input and output voltage ratings may be exceeded if the input and output clamp-current ratings are observed.
- (5) This value is limited to 5.5 V maximum.
- (6) The package thermal impedance is calculated in accordance with JESD 51-7.

Electrical Characteristics for 5-V Supply⁽¹⁾
 $V_+ = 4.5\text{ V to }5.5\text{ V}$, $T_A = -40^\circ\text{C to }85^\circ\text{C}$ (unless otherwise noted)

PARAMETER	SYMBOL	TEST CONDITIONS	T_A	V_+	MIN	TYP	MAX	UNIT
Analog Switch								
Analog signal range	V_{COM}, V_{NO}				0		V_+	V
ON-state resistance	r_{on}	$0 \leq V_{NO} \leq V_+$, $I_{COM} = -32\text{ mA}$, Switch ON, See Figure 13	25°C Full	4.5 V		7.5	10 15	Ω
ON-state resistance match between channels	Δr_{on}	$V_{NO} = 3.15\text{ V}$, $I_{COM} = -32\text{ mA}$, Switch ON, See Figure 13	25°C Full	4.5 V		0.4	1 3	Ω
ON-state resistance flatness	$r_{on(Flat)}$	$0 \leq V_{NO} \leq V_+$, $I_{COM} = -32\text{ mA}$, Switch ON, See Figure 13	25°C Full	4.5 V		2 4	3.5 8	Ω
NO OFF leakage current	$I_{NO(OFF)}$	$V_{NO} = 1\text{ V}$, $V_{COM} = 4.5\text{ V}$, or $V_{NO} = 4.5\text{ V}$, $V_{COM} = 1\text{ V}$, Switch OFF, See Figure 14	25°C Full	5.5 V		-30 -40	-10 40	nA
COM OFF leakage current	$I_{COM(OFF)}$	$V_{COM} = 1\text{ V}$, $V_{NO} = 4.5\text{ V}$, or $V_{COM} = 4.5\text{ V}$, $V_{NO} = 1\text{ V}$, Switch OFF, See Figure 14	25°C Full	5.5 V		-50 -50	-8 50	nA
NO ON leakage current	$I_{NO(ON)}$	$V_{NO} = 1\text{ V}$, $V_{COM} = \text{Open}$, or $V_{NO} = 4.5\text{ V}$, $V_{COM} = \text{Open}$, Switch ON, See Figure 15	25°C Full	5.5 V		-40 -4	-12 40	nA
COM ON leakage current	$I_{COM(ON)}$	$V_{COM} = 1\text{ V}$, $V_{NO} = \text{Open}$, or $V_{COM} = 4.5\text{ V}$, $V_{NO} = \text{Open}$, Switch ON, See Figure 15	25°C Full	5.5 V		-70 -70	-30 70	nA
Digital Control Input (IN)								
Input logic high	V_{IH}		Full		$V_+ \times 0.7$		5.5	V
Input logic low	V_{IL}		Full		0		$V_+ \times 0.3$	V
Input leakage current	I_{IH}, I_{IL}	$V_I = 5.5\text{ V or }0$	25°C Full	5.5 V		-0.1 -1	0.05 1	μA

(1) The algebraic convention, whereby the most negative value is a minimum and the most positive value is a maximum

Electrical Characteristics for 5-V Supply ⁽¹⁾ (continued)V₊ = 4.5 V to 5.5 V, T_A = –40°C to 85°C (unless otherwise noted)

PARAMETER	SYMBOL	TEST CONDITIONS	T _A	V ₊	MIN	TYP	MAX	UNIT
Dynamic								
Turn-on time	t _{ON}	V _{COM} = 3 V, R _L = 300 Ω, C _L = 35 pF, See Figure 17	25°C	5 V	4.4	5.2	5.8	ns
			Full	4.5 V to 5.5 V	3.4		6.1	
Turn-off time	t _{OFF}	V _{COM} = 3 V, R _L = 300 Ω, C _L = 35 pF, See Figure 17	25°C	5 V	1.7	2.6	3.6	ns
			Full	4.5 V to 5.5 V	1.3		4.2	
Charge injection	Q _C	V _{GEN} = 0, R _{GEN} = 0, C _L = 0.1 nF, See Figure 21	25°C	5 V		1		pC
NO OFF capacitance	C _{NO(OFF)}	V _{NO} = V ₊ or GND, Switch OFF, See Figure 16	25°C	5 V		5.5		pF
COM OFF capacitance	C _{COM(OFF)}	V _{COM} = V ₊ or GND, Switch OFF, See Figure 16	25°C	5 V		5.5		pF
NO ON capacitance	C _{NO(ON)}	V _{NO} = V ₊ or GND, Switch ON, See Figure 16	25°C	5 V		13.5		pF
COM ON capacitance	C _{COM(ON)}	V _{COM} = V ₊ or GND, Switch ON, See Figure 16	25°C	5 V		13.5		pF
Digital input capacitance	C _I	V _I = V ₊ or GND, See Figure 16	25°C	5 V		2.5		pF
Bandwidth	BW	R _L = 50 Ω, Switch ON, See Figure 18	25°C	5 V		300		MHz
OFF isolation	O _{ISO}	R _L = 50 Ω, f = 10 MHz, Switch OFF, See Figure 19	25°C	5 V		–68		dB
Crosstalk	X _{TALK}	R _L = 50 Ω, f = 10 MHz, Switch ON, See Figure 20	25°C	5 V		–66		dB
Total harmonic distortion	THD	R _L = 600 Ω, C _L = 50 pF, f = 20 Hz to 20 kHz, See Figure 22	25°C	5 V		0.01		%
Supply								
Positive supply current	I ₊	V _I = V ₊ or GND, Switch ON or OFF	25°C	5.5 V	0.1			μA
			Full		1			
					5			

Electrical Characteristics for 3.3-V Supply⁽¹⁾
 $V_+ = 3\text{ V to }3.6\text{ V}$, $T_A = -40^\circ\text{C to }85^\circ\text{C}$ (unless otherwise noted)

PARAMETER	SYMBOL	TEST CONDITIONS	T_A	V_+	MIN	TYP	MAX	UNIT
Analog Switch								
Analog signal range	V_{COM}, V_{NO}				0		V_+	V
ON-state resistance	r_{on}	$0 \leq V_{NO} \leq V_+$, $I_{COM} = -24\text{ mA}$, Switch ON, See Figure 13	25°C	3 V	10	12	15	Ω
			Full		12		20	
ON-state resistance match between channels	Δr_{on}	$V_{NO} = 2.1\text{ V}$, $I_{COM} = -24\text{ mA}$, Switch ON, See Figure 13	25°C	3 V	0.04	0.5	1.5	Ω
			Full		0.01		3.5	
ON-state resistance flatness	$r_{on(flat)}$	$0 \leq V_{NO} \leq V_+$, $I_{COM} = -24\text{ mA}$, Switch ON, See Figure 13	25°C	3 V	6	7	8	Ω
			Full		9		12	
NO OFF leakage current	$I_{NO(OFF)}$	$V_{NO} = 1\text{ V}$, $V_{COM} = 3\text{ V}$, or $V_{NO} = 3\text{ V}$, $V_{COM} = 1\text{ V}$, Switch OFF, See Figure 14	25°C	3.6 V	-30	-6	30	nA
			Full		-40		40	
COM OFF leakage current	$I_{COM(OFF)}$	$V_{COM} = 1\text{ V}$, $V_{NO} = 3\text{ V}$, or $V_{COM} = 3\text{ V}$, $V_{NO} = 1\text{ V}$, Switch OFF, See Figure 14	25°C	3.6 V	-50	-7	50	nA
			Full		-50		50	
NO ON leakage current	$I_{NO(ON)}$	$V_{NO} = 1\text{ V}$, $V_{COM} = \text{Open}$, or $V_{NO} = 3\text{ V}$, $V_{COM} = \text{Open}$, Switch ON, See Figure 15	25°C	3.6 V	-40	-7	40	nA
			Full		-40		40	
COM ON leakage current	$I_{COM(ON)}$	$V_{COM} = 1\text{ V}$, $V_{NO} = \text{Open}$, or $V_{COM} = 3\text{ V}$, $V_{NO} = \text{Open}$, Switch ON, See Figure 15	25°C	3.6 V	-70	-20	70	nA
			Full		-70		70	
Digital Control Input (IN)								
Input logic high	V_{IH}		Full		$V_+ \times 0.7$		5.5	V
Input logic low	V_{IL}		Full		0		$V_+ \times 0.3$	V
Input leakage current	I_{IH}, I_{IL}	$V_I = 5.5\text{ V or }0$	25°C	3.6 V	-0.1	0.05	0.1	μA
			Full		-1		1	

(1) The algebraic convention, whereby the most negative value is a minimum and the most positive value is a maximum

Electrical Characteristics for 3.3-V Supply ⁽¹⁾ (continued) $V_+ = 3\text{ V to }3.6\text{ V}$, $T_A = -40^\circ\text{C to }85^\circ\text{C}$ (unless otherwise noted)

PARAMETER	SYMBOL	TEST CONDITIONS	T_A	V_+	MIN	TYP	MAX	UNIT	
Dynamic									
Turn-on time	t_{ON}	$V_{COM} = 2\text{ V}$, $R_L = 300\ \Omega$,	$C_L = 35\text{ pF}$, See Figure 17	25°C	3.3 V	4.9	5.6	6.4	ns
				Full	3 V to 3.6 V	4.3		7.1	
Turn-off time	t_{OFF}	$V_{COM} = 2\text{ V}$, $R_L = 300\ \Omega$,	$C_L = 35\text{ pF}$, See Figure 17	25°C	3.3 V	2	2.7	3.7	ns
				Full	3 V to 3.6 V	1.3		4.7	
Charge injection	Q_C	$V_{GEN} = 0$, $R_{GEN} = 0$,	$C_L = 0.1\text{ nF}$, See Figure 21	25°C	3.3 V		0.5	pC	
NO OFF capacitance	$C_{NO(OFF)}$	$V_{NO} = V_+$ or GND, Switch OFF,	See Figure 16	25°C	3.3 V		5.5	pF	
COM OFF capacitance	$C_{COM(OFF)}$	$V_{COM} = V_+$ or GND, Switch OFF,	See Figure 16	25°C	3.3 V		6	pF	
NO ON capacitance	$C_{NO(ON)}$	$V_{NO} = V_+$ or GND, Switch ON,	See Figure 16	25°C	3.3 V		14	pF	
COM ON capacitance	$C_{COM(ON)}$	$V_{COM} = V_+$ or GND, Switch ON,	See Figure 16	25°C	3.3 V		14	pF	
Digital input capacitance	C_I	$V_I = V_+$ or GND,	See Figure 16	25°C	3.3 V		3	pF	
Bandwidth	BW	$R_L = 50\ \Omega$, Switch ON,	See Figure 18	25°C	3.3 V		300	MHz	
OFF isolation	O_{ISO}	$R_L = 50\ \Omega$, $f = 10\text{ MHz}$,	Switch OFF, See Figure 19	25°C	3.3 V		-68	dB	
Crosstalk	X_{TALK}	$R_L = 50\ \Omega$, $f = 10\text{ MHz}$,	Switch ON, See Figure 20	25°C	3.3 V		-66	dB	
Total harmonic distortion	THD	$R_L = 600\ \Omega$, $C_L = 50\text{ pF}$,	$f = 20\text{ Hz to }20\text{ kHz}$, See Figure 22	25°C	3.3 V		0.065	%	
Supply									
Positive supply current	I_+	$V_I = V_+$ or GND,	Switch ON or OFF	25°C	3.6 V		0.1	1	μA
				Full				5	

Electrical Characteristics for 2.5-V Supply⁽¹⁾
 $V_+ = 2.3\text{ V to }2.7\text{ V}$, $T_A = -40^\circ\text{C to }85^\circ\text{C}$ (unless otherwise noted)

PARAMETER	SYMBOL	TEST CONDITIONS	T_A	V_+	MIN	TYP	MAX	UNIT
Analog Switch								
Analog signal range	V_{COM}, V_{NO}				0		V_+	V
ON-state resistance	r_{on}	$0 \leq V_{NO} \leq V_+$, $I_{COM} = -8\text{ mA}$, Switch ON, See Figure 13	25°C	2.3 V	20	22		Ω
			Full				30	
ON-state resistance match between channels	Δr_{on}	$V_{NO} = 1.6\text{ V}$, $I_{COM} = -8\text{ mA}$, Switch ON, See Figure 13	25°C	2.3 V	0.04	0.5	1.5	Ω
			Full		0.02		5	
ON-state resistance flatness	$r_{on(Flat)}$	$0 \leq V_{NO} \leq V_+$, $I_{COM} = -8\text{ mA}$, Switch ON, See Figure 13	25°C	2.3 V	12	16	18	Ω
			Full		15		25	
NO OFF leakage current	$I_{NO(OFF)}$	$V_{NO} = 0.5\text{ V}$, $V_{COM} = 2.2\text{ V}$, or $V_{NO} = 2.2\text{ V}$, $V_{COM} = 0.5\text{ V}$, Switch OFF, See Figure 14	25°C	2.7 V	-30	-5.5	30	nA
			Full		-40		40	
COM OFF leakage current	$I_{COM(OFF)}$	$V_{COM} = 0.5\text{ V}$, $V_{NO} = 2.2\text{ V}$, or $V_{COM} = 2.2\text{ V}$, $V_{NO} = 0.5\text{ V}$, Switch OFF, See Figure 14	25°C	2.7 V	-50	-7.5	50	nA
			Full		-50		50	
NO ON leakage current	$I_{NO(ON)}$	$V_{NO} = 0.5\text{ V}$, $V_{COM} = \text{Open}$, or $V_{NO} = 2.2\text{ V}$, $V_{COM} = \text{Open}$, Switch ON, See Figure 15	25°C	2.7 V	-40	-5	40	nA
			Full		-40		40	
COM ON leakage current	$I_{COM(ON)}$	$V_{COM} = 0.5\text{ V}$, $V_{NO} = \text{Open}$, or $V_{COM} = 2.2\text{ V}$, $V_{NO} = \text{Open}$, Switch ON, See Figure 15	25°C	2.7 V	-70	-12	70	nA
			Full		-70		70	
Digital Control Input (IN)								
Input logic high	V_{IH}		Full		$V_+ \times 0.7$		5.5	V
Input logic low	V_{IL}		Full		0		$V_+ \times 0.3$	V
Input leakage current	I_{IH}, I_{IL}	$V_I = 5.5\text{ V or }0$	25°C	2.7 V	-0.1	0.05	0.1	μA
			Full		-1		1	

(1) The algebraic convention, whereby the most negative value is a minimum and the most positive value is a maximum

Electrical Characteristics for 2.5-V Supply ⁽¹⁾ (continued) $V_+ = 2.3 \text{ V to } 2.7 \text{ V}$, $T_A = -40^\circ\text{C to } 85^\circ\text{C}$ (unless otherwise noted)

PARAMETER	SYMBOL	TEST CONDITIONS	T_A	V_+	MIN	TYP	MAX	UNIT	
Dynamic									
Turn-on time	t_{ON}	$V_{COM} = 1.5 \text{ V}$, $R_L = 300 \Omega$,	$C_L = 35 \text{ pF}$, See Figure 17	25°C	2.5 V	5.7	6.4	8.1	ns
				Full	2.3 V to 2.7 V	4.4		8.5	
Turn-off time	t_{OFF}	$V_{COM} = 1.5 \text{ V}$, $R_L = 300 \Omega$,	$C_L = 35 \text{ pF}$, See Figure 17	25°C	2.5 V	2.1	3.1	4.3	ns
				Full	2.3 V to 2.7 V	1.8		4.8	
Charge injection	Q_C	$V_{GEN} = 0$, $R_{GEN} = 0$,	$C_L = 0.1 \text{ nF}$, See Figure 20	25°C	2.5 V	0.5		pC	
NO OFF capacitance	$C_{NO(OFF)}$	$V_{NO} = V_+$ or GND, Switch OFF,	See Figure 16	25°C	2.5 V	6		pF	
COM OFF capacitance	$C_{COM(OFF)}$	$V_{COM} = V_+$ or GND, Switch OFF,	See Figure 16	25°C	2.5 V	6		pF	
NO ON capacitance	$C_{NO(ON)}$	$V_{NO} = V_+$ or GND, Switch ON,	See Figure 16	25°C	2.5 V	14		pF	
COM ON capacitance	$C_{COM(ON)}$	$V_{COM} = V_+$ or GND, Switch ON,	See Figure 16	25°C	2.5 V	14		pF	
Digital input capacitance	C_I	$V_I = V_+$ or GND,	See Figure 16	25°C	2.5 V	3		pF	
Bandwidth	BW	$R_L = 50 \Omega$, Switch ON,	See Figure 18	25°C	2.5 V	300		MHz	
OFF isolation	O_{ISO}	$R_L = 50 \Omega$, $f = 10 \text{ MHz}$,	Switch OFF, See Figure 19	25°C	2.5 V	-68		dB	
Crosstalk	X_{TALK}	$R_L = 50 \Omega$, $f = 10 \text{ MHz}$,	Switch ON, See Figure 20	25°C	2.5 V	-66		dB	
Total harmonic distortion	THD	$R_L = 600 \Omega$, $C_L = 50 \text{ pF}$,	$f = 20 \text{ Hz to } 20 \text{ kHz}$, See Figure 22	25°C	2.5 V	0.35		%	
Supply									
Positive supply current	I_+	$V_I = V_+$ or GND,	Switch ON or OFF	25°C	2.7 V	0.1		1	μA
				Full				5	

Electrical Characteristics for 1.8-V Supply⁽¹⁾
 $V_+ = 1.65\text{ V to }1.95\text{ V}$, $T_A = -40^\circ\text{C to }85^\circ\text{C}$ (unless otherwise noted)

PARAMETER	SYMBOL	TEST CONDITIONS	T_A	V_+	MIN	TYP	MAX	UNIT
Analog Switch								
Analog signal range	V_{COM}, V_{NO}				0		V_+	V
ON-state resistance	r_{on}	$0 \leq V_{NO} \leq V_+$, $I_{COM} = -4\text{ mA}$,	Switch ON, See Figure 13	25°C	1.65 V	80	85	Ω
				Full		90	120	
ON-state resistance match between channels	Δr_{on}	$V_{NO} = 1.15\text{ V}$, $I_{COM} = -4\text{ mA}$,	Switch ON, See Figure 13	25°C	1.65 V	0	0.9	Ω
				Full		0	6	
ON-state resistance flatness	$r_{on(Flat)}$	$0 \leq V_{NO} \leq V_+$, $I_{COM} = -4\text{ mA}$,	Switch ON, See Figure 13	25°C	1.65 V	70	75	Ω
				Full		85	100	
NO OFF leakage current	$I_{NO(OFF)}$	$V_{NO} = 0.3\text{ V}$, $V_{COM} = 1.65\text{ V}$, or $V_{NO} = 1.65\text{ V}$, $V_{COM} = 0.3\text{ V}$,	Switch OFF, See Figure 14	25°C	1.95 V	-30	-6	nA
				Full		-40	40	
COM OFF leakage current	$I_{COM(OFF)}$	$V_{COM} = 0.3\text{ V}$, $V_{NO} = 1.65\text{ V}$, or $V_{COM} = 1.65\text{ V}$, $V_{NO} = 0.3\text{ V}$,	Switch OFF, See Figure 14	25°C	1.95 V	-50	-7	nA
				Full		-50	50	
NO ON leakage current	$I_{NO(ON)}$	$V_{NO} = 0.3\text{ V}$, $V_{COM} = \text{Open}$, or $V_{NO} = 1.65\text{ V}$, $V_{COM} = \text{Open}$,	Switch ON, See Figure 15	25°C	1.95 V	-40	7	nA
				Full		-40	40	
COM ON leakage current	$I_{COM(ON)}$	$V_{COM} = 0.3\text{ V}$, $V_{NO} = \text{Open}$, or $V_{COM} = 1.65\text{ V}$, $V_{NO} = \text{Open}$,	Switch ON, See Figure 15	25°C	1.95 V	-70	-8.5	nA
				Full		-70	70	
Digital Control Input (IN)								
Input logic high	V_{IH}		Full		$V_+ \times 0.65$		5.5	V
Input logic low	V_{IL}		Full		0		$V_+ \times 0.35$	V
Input leakage current	I_{IH}, I_{IL}	$V_I = 5.5\text{ V or }0$	25°C	1.95 V	-0.1	0.05	0.1	μA
			Full		-1	1		

(1) The algebraic convention, whereby the most negative value is a minimum and the most positive value is a maximum

Electrical Characteristics for 1.8-V Supply ⁽¹⁾ (continued)
 $V_+ = 1.65 \text{ V to } 1.95 \text{ V}$, $T_A = -40^\circ\text{C to } 85^\circ\text{C}$ (unless otherwise noted)

PARAMETER	SYMBOL	TEST CONDITIONS	T_A	V_+	MIN	TYP	MAX	UNIT	
Dynamic									
Turn-on time	t_{ON}	$V_{COM} = 1.3 \text{ V}$, $R_L = 300 \Omega$, $C_L = 35 \text{ pF}$, See Figure 17	25°C	1.8 V	9.3	10.4	11.5	ns	
			Full	1.65 V to 1.95 V	6.8		12.9		
Turn-off time	t_{OFF}	$V_{COM} = 1.3 \text{ V}$, $R_L = 300 \Omega$, $C_L = 35 \text{ pF}$, See Figure 17	25°C	1.8 V	3.3	4.3	5.2	ns	
			Full	1.65 V to 1.95 V	2.4		6.5		
Charge injection	Q_C	$V_{GEN} = 0$, $R_{GEN} = 0$, $C_L = 0.1 \text{ nF}$, See Figure 21	25°C	1.8 V		0.5		pC	
NO OFF capacitance	$C_{NO(OFF)}$	$V_{NO} = V_+$ or GND, Switch OFF, See Figure 16	25°C	1.8 V		6		pF	
COM OFF capacitance	$C_{COM(OFF)}$	$V_{COM} = V_+$ or GND, Switch OFF, See Figure 16	25°C	1.8 V		6		pF	
NO ON capacitance	$C_{NO(ON)}$	$V_{NO} = V_+$ or GND, Switch ON, See Figure 16	25°C	1.8 V		14.5		pF	
COM ON capacitance	$C_{COM(ON)}$	$V_{COM} = V_+$ or GND, Switch ON, See Figure 16	25°C	1.8 V		14.5		pF	
Digital input capacitance	C_I	$V_I = V_+$ or GND, See Figure 16	25°C	1.8 V		3		pF	
Bandwidth	BW	$R_L = 50 \Omega$, Switch ON, See Figure 18	25°C	1.8 V		293		MHz	
OFF isolation	O_{ISO}	$R_L = 50 \Omega$, $f = 10 \text{ MHz}$, Switch OFF, See Figure 19	25°C	1.8 V		-68		dB	
Crosstalk	X_{TALK}	$R_L = 50 \Omega$, $f = 10 \text{ MHz}$, Switch ON, See Figure 20	25°C	1.8 V		-66		dB	
Total harmonic distortion	THD	$R_L = 10 \text{ k}\Omega$, $C_L = 50 \text{ pF}$, $f = 20 \text{ Hz to } 20 \text{ kHz}$, See Figure 22	25°C	1.8 V		2.7		%	
Supply									
Positive supply current	I_+	$V_I = V_+$ or GND, Switch ON or OFF	25°C	1.95 V	0.1			1	μA
			Full					5	

TYPICAL PERFORMANCE

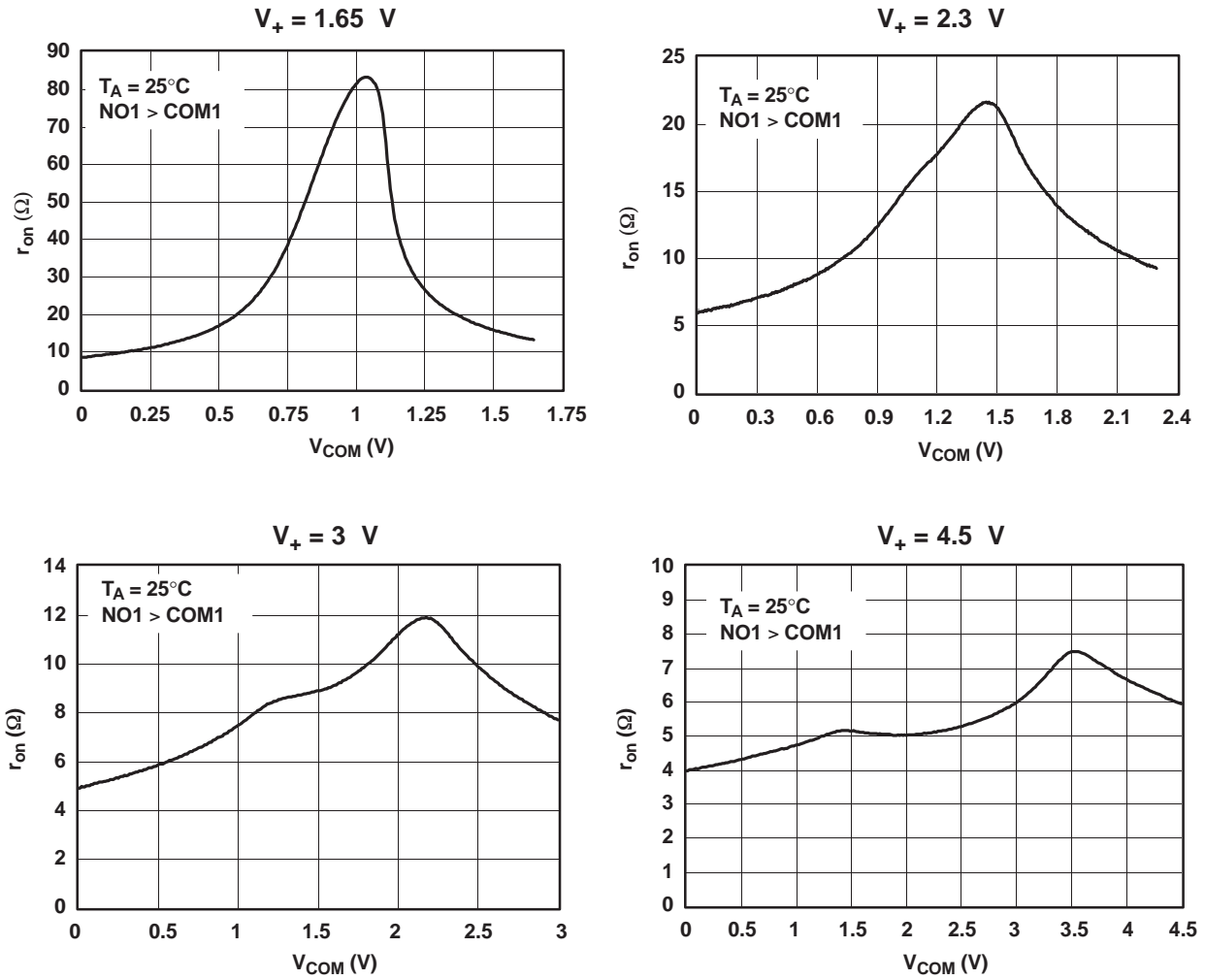

Figure 1. r_{on} vs V_{COM}

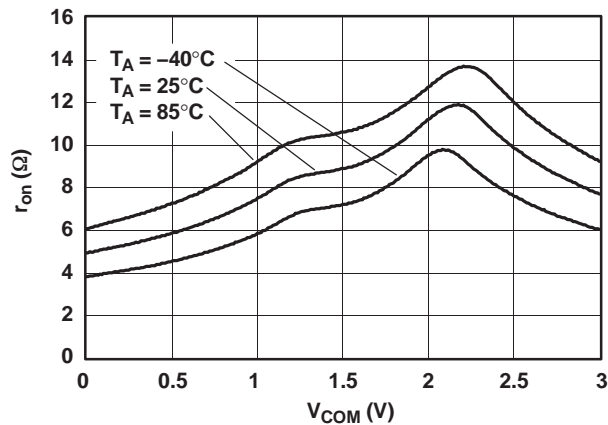

Figure 2. r_{on} vs V_{COM} ($V_+ = 3\text{ V}$)

TYPICAL PERFORMANCE (continued)

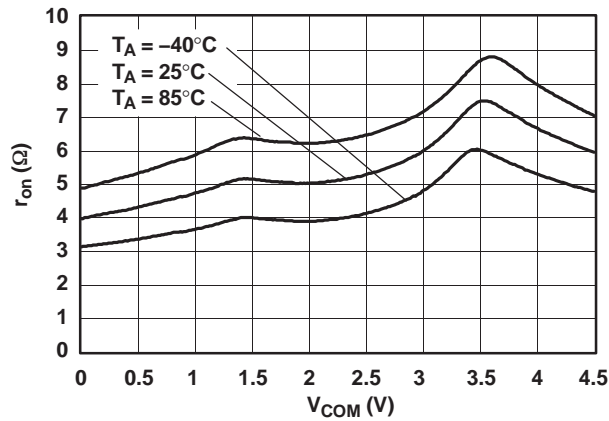

Figure 3. r_{on} vs V_{COM} ($V_+ = 4.5\text{ V}$)

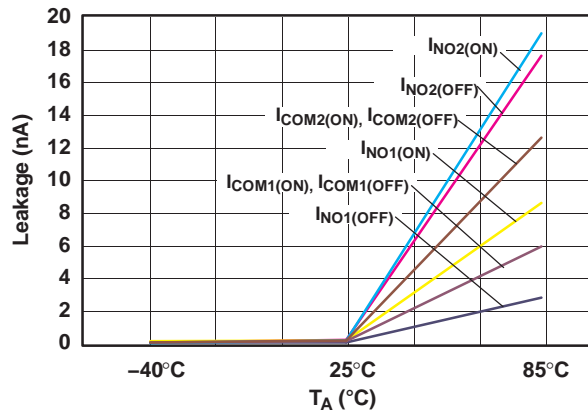

Figure 4. Leakage Current vs Temperature

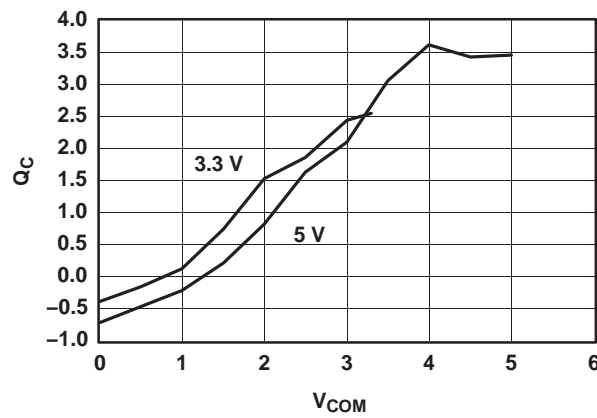

Figure 5. Charge Injection (Q_C) vs V_{COM}

TYPICAL PERFORMANCE (continued)

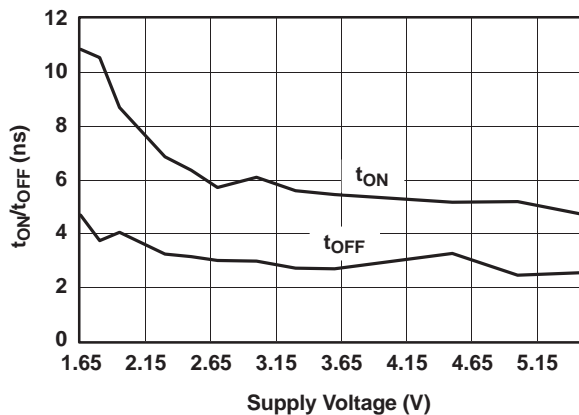

Figure 6. t_{ON} and t_{OFF} vs V₊

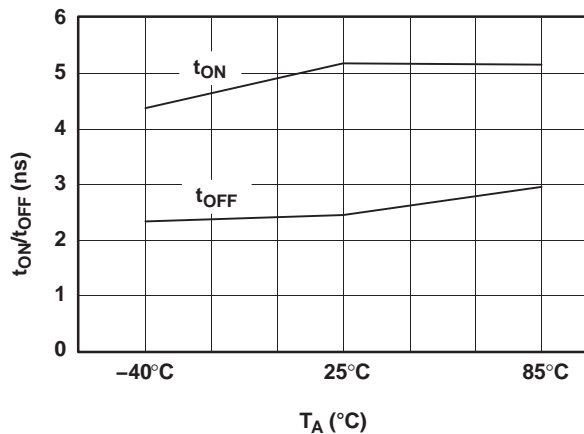

Figure 7. t_{ON} and t_{OFF} vs Temperature (V₊ = 5 V)

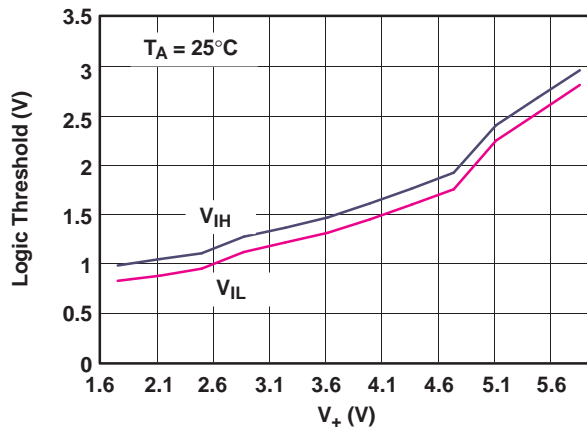

Figure 8. Logic Threshold vs V₊

TYPICAL PERFORMANCE (continued)

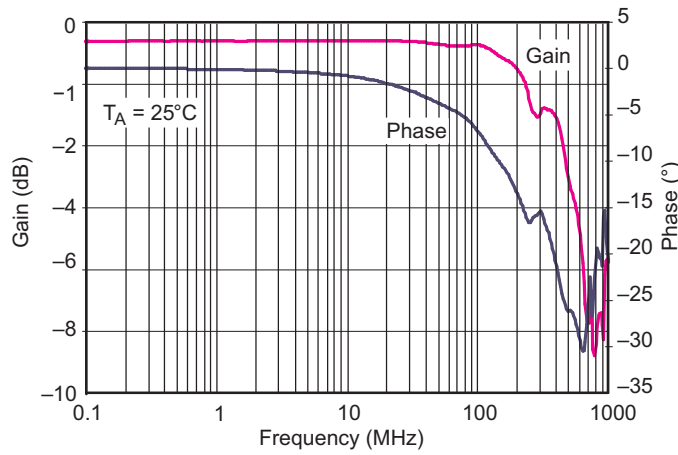

Figure 9. Bandwidth ($V_+ = 5\text{ V}$)

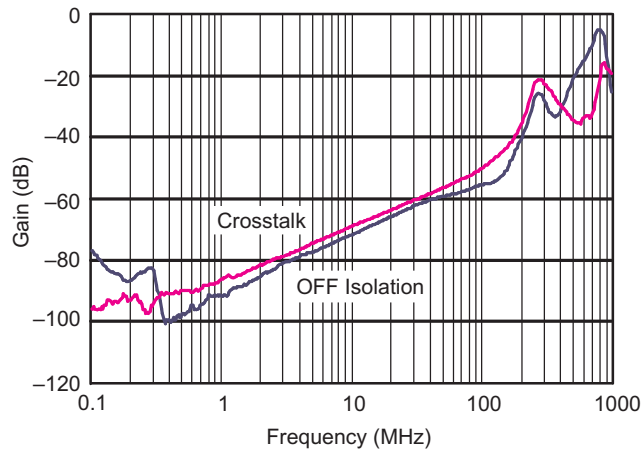

Figure 10. OFF Isolation and Crosstalk ($V_+ = 5\text{ V}$)

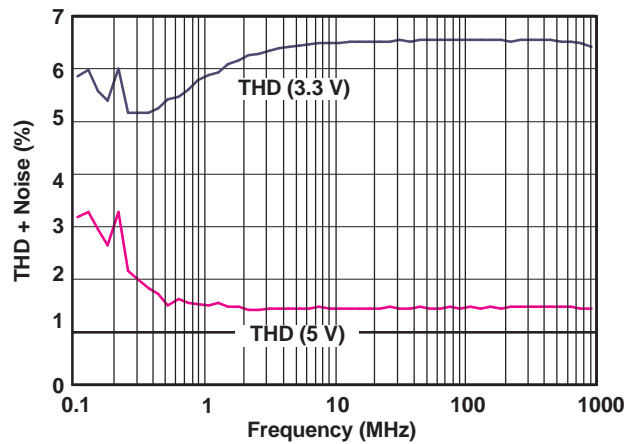
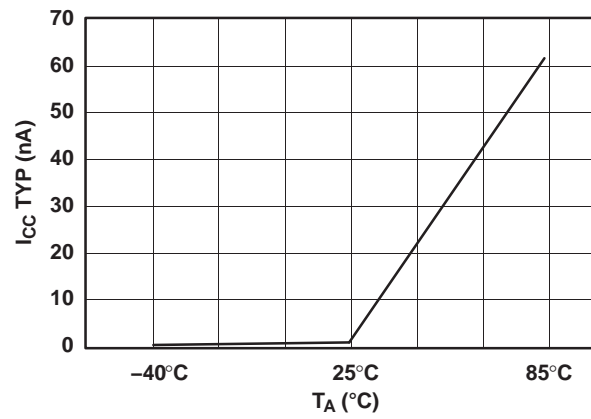

Figure 11. Total Harmonic Distortion vs Frequency

TYPICAL PERFORMANCE (continued)



**Figure 12. Power-Supply Current vs Temperature
(V₊ = 5 V)**

Table 2. PIN DESCRIPTION

NO.	NAME	DESCRIPTION
1	NO1	Normally open
2	COM1	Common
3	IN2	Digital control to connect COM to NO
4	GND	Digital ground
5	NO2	Normally open
6	COM2	Common
7	IN1	Digital control to connect COM to NO
8	V ₊	Power supply

Table 3. PARAMETER DESCRIPTION

SYMBOL	DESCRIPTION
V _{COM}	Voltage at COM
V _{NO}	Voltage at NO
r _{on}	Resistance between COM and NO ports when the channel is ON
Δr _{on}	Difference of r _{on} between channels in a specific device
r _{on(flat)}	Difference between the maximum and minimum value of r _{on} in a channel over the specified range of conditions
I _{NO(OFF)}	Leakage current measured at the NO port, with the corresponding channel (NO to COM) in the OFF state
I _{NO(ON)}	Leakage current measured at the NO port, with the corresponding channel (NO to COM) in the ON state and the output (COM) open
I _{COM(OFF)}	Leakage current measured at the COM port, with the corresponding channel (COM to NO) in the OFF state
I _{COM(ON)}	Leakage current measured at the COM port, with the corresponding channel (COM to NO) in the ON state and the output (NO) open
V _{IH}	Minimum input voltage for logic high for the control input (IN)
V _{IL}	Maximum input voltage for logic low for the control input (IN)
V _I	Voltage at the control input (IN)
I _{IH} , I _{IL}	Leakage current measured at the control input (IN)
t _{ON}	Turn-on time for the switch. This parameter is measured under the specified range of conditions and by the propagation delay between the digital control (IN) signal and analog output (COM or NO) signal when the switch is turning ON.
t _{OFF}	Turn-off time for the switch. This parameter is measured under the specified range of conditions and by the propagation delay between the digital control (IN) signal and analog output (COM or NO) signal when the switch is turning OFF.
Q _C	Charge injection is a measurement of unwanted signal coupling from the control (IN) input to the analog (NO or COM) output. This is measured in coulomb (C) and measured by the total charge induced due to switching of the control input. Charge injection, Q _C = C _L × ΔV _{COM} , C _L is the load capacitance and ΔV _{COM} is the change in analog output voltage.
C _{NO(OFF)}	Capacitance at the NO port when the corresponding channel (NO to COM) is OFF
C _{NO(ON)}	Capacitance at the NO port when the corresponding channel (NO to COM) is ON
C _{COM(OFF)}	Capacitance at the COM port when the corresponding channel (COM to NO) is OFF
C _{COM(ON)}	Capacitance at the COM port when the corresponding channel (COM to NO) is ON
C _I	Capacitance of IN
O _{ISO}	OFF isolation of the switch is a measurement of OFF-state switch impedance. This is measured in dB in a specific frequency, with the corresponding channel (NO to COM) in the OFF state.
X _{TALK}	Crosstalk is a measurement of unwanted signal coupling from an ON channel to an adjacent ON channel (NC1 to NC2). This is measured in a specific frequency and in dB.
BW	Bandwidth of the switch. This is the frequency in which the gain of an ON channel is –3 dB below the DC gain.
THD	Total harmonic distortion is defined as the ratio of the root mean square (RMS) value of the second, third, and higher harmonics to the magnitude of fundamental harmonic.
I ₊	Static power-supply current with the control (IN) pin at V ₊ or GND

PARAMETER MEASUREMENT INFORMATION

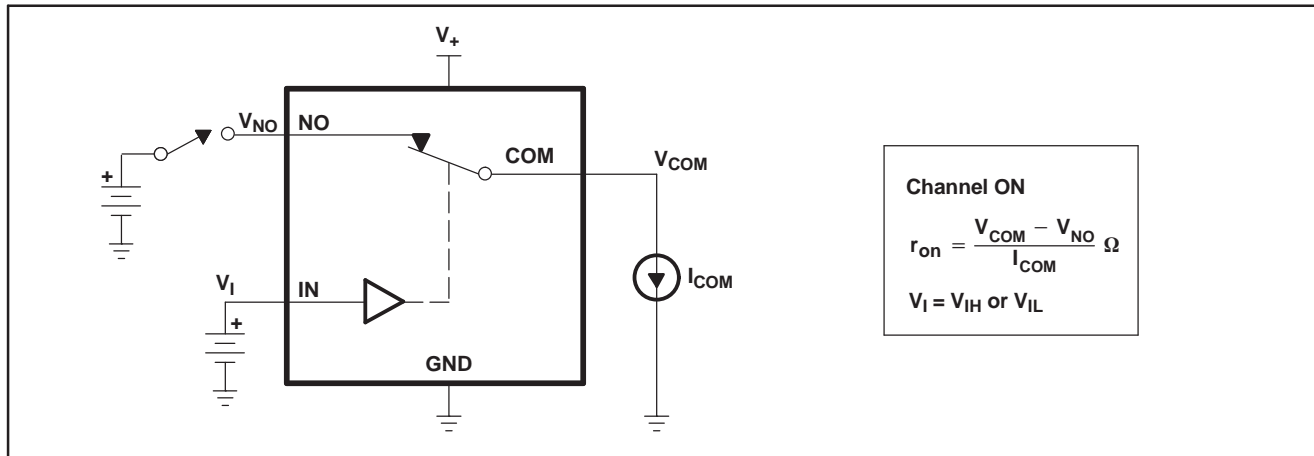

Figure 13. ON-State Resistance (r_{on})

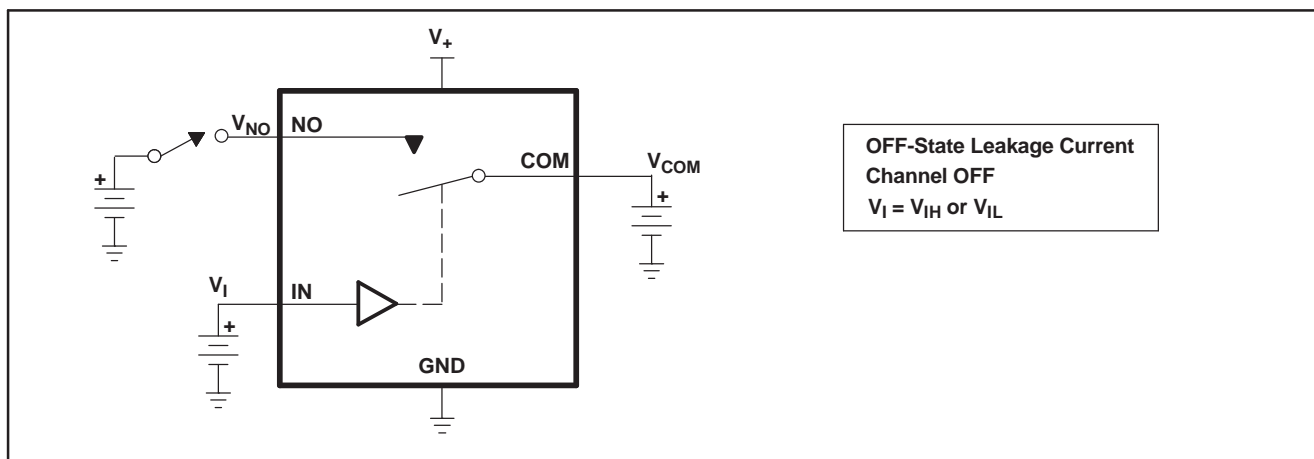

Figure 14. OFF-State Leakage Current ($I_{COM(OFF)}$, $I_{NO(OFF)}$)

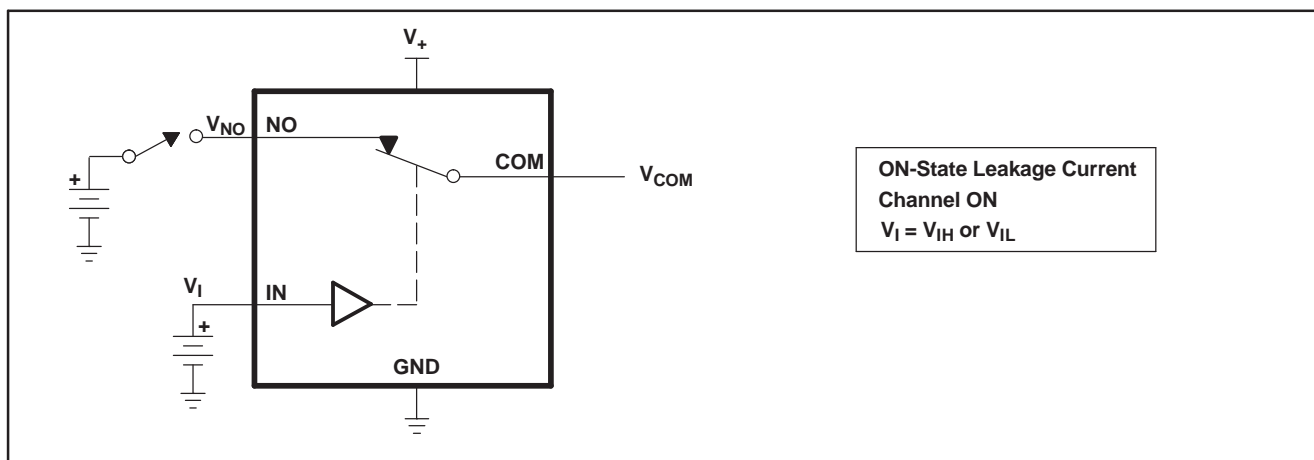

Figure 15. ON-State Leakage Current ($I_{COM(ON)}$, $I_{NO(ON)}$)

PARAMETER MEASUREMENT INFORMATION (continued)

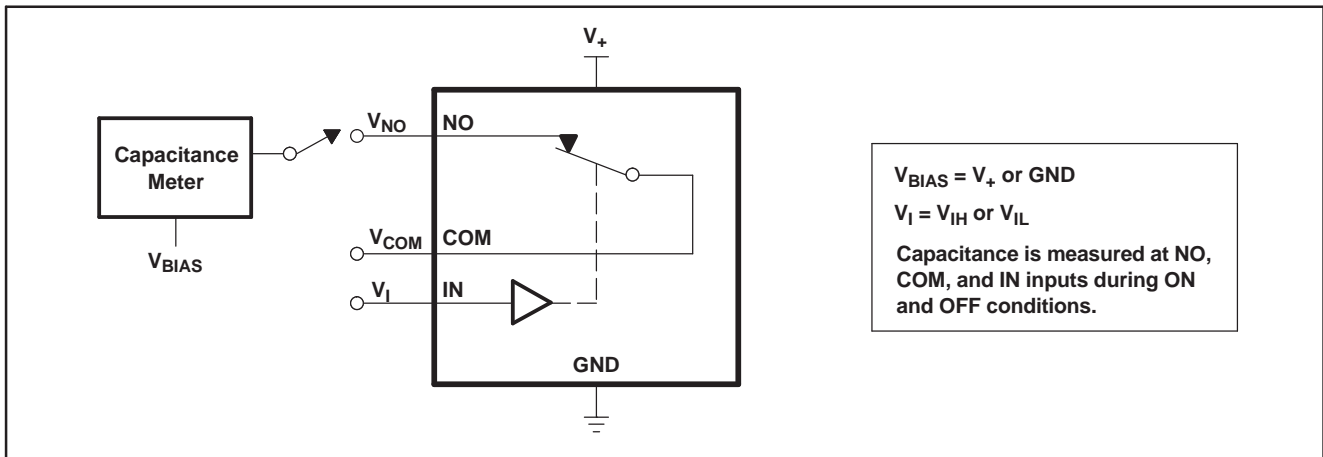

Figure 16. Capacitance (C_I , $C_{COM(OFF)}$, $C_{COM(ON)}$, $C_{NO(OFF)}$, $C_{NO(ON)}$)

- (1) All input pulses are supplied by generators having the following characteristics: $PRR \leq 10$ MHz, $Z_O = 50 \Omega$, $t_r < 5$ ns, $t_f < 5$ ns.
- (2) C_L includes probe and jig capacitance.
- (3) See Electrical Characteristics for V_{COM} .

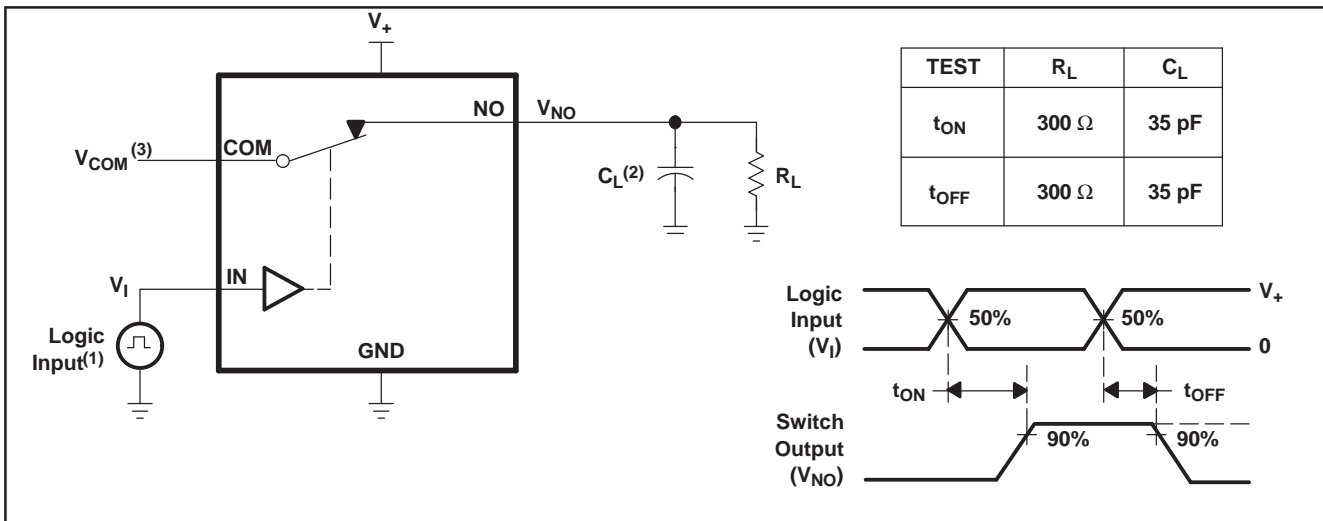

Figure 17. Turn-On (t_{ON}) and Turn-Off Time (t_{OFF})

PARAMETER MEASUREMENT INFORMATION (continued)

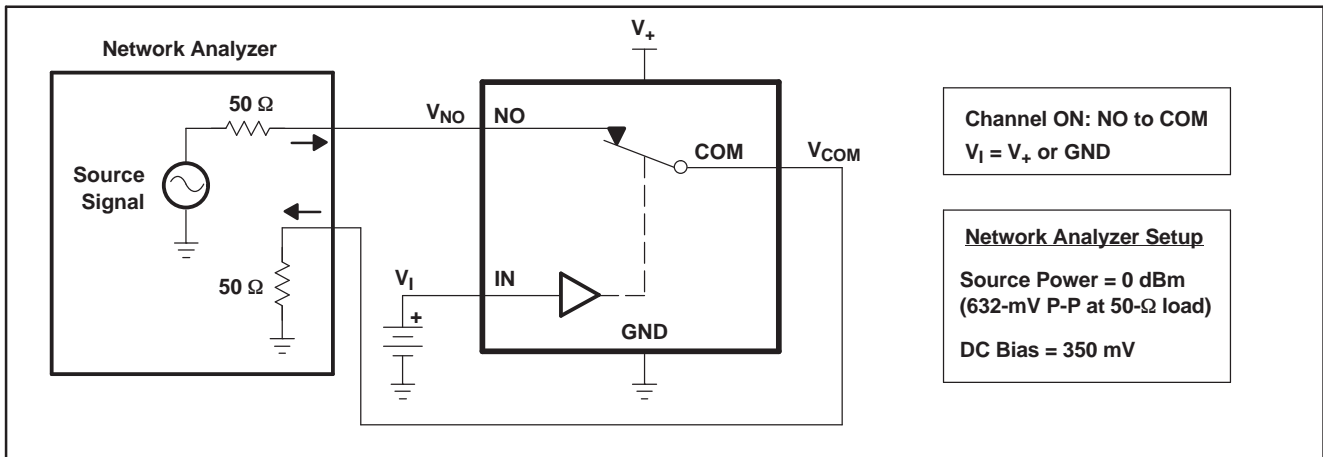

Figure 18. Bandwidth (BW)

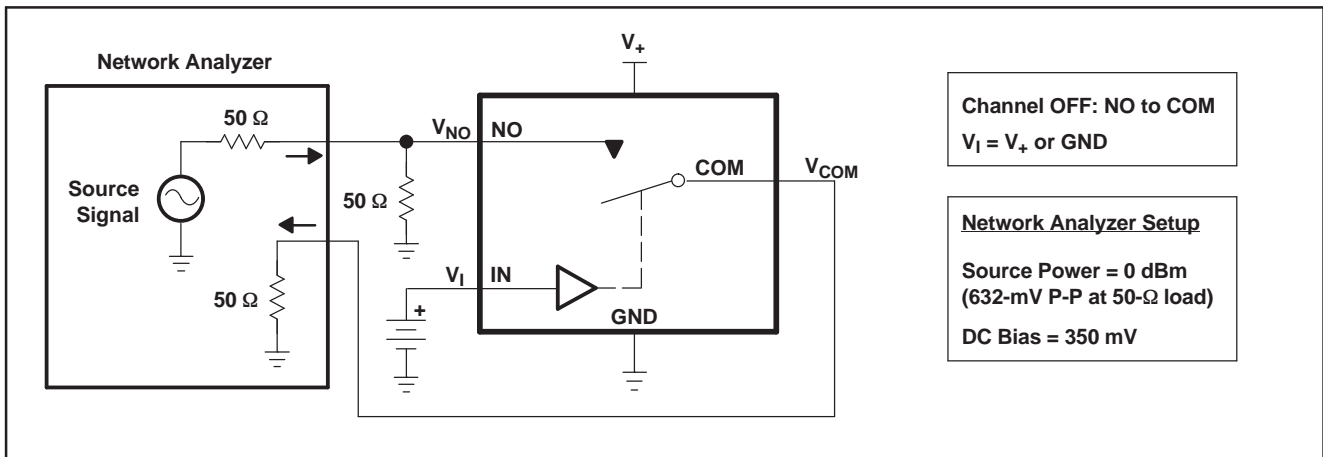

Figure 19. OFF Isolation (O_{ISO})

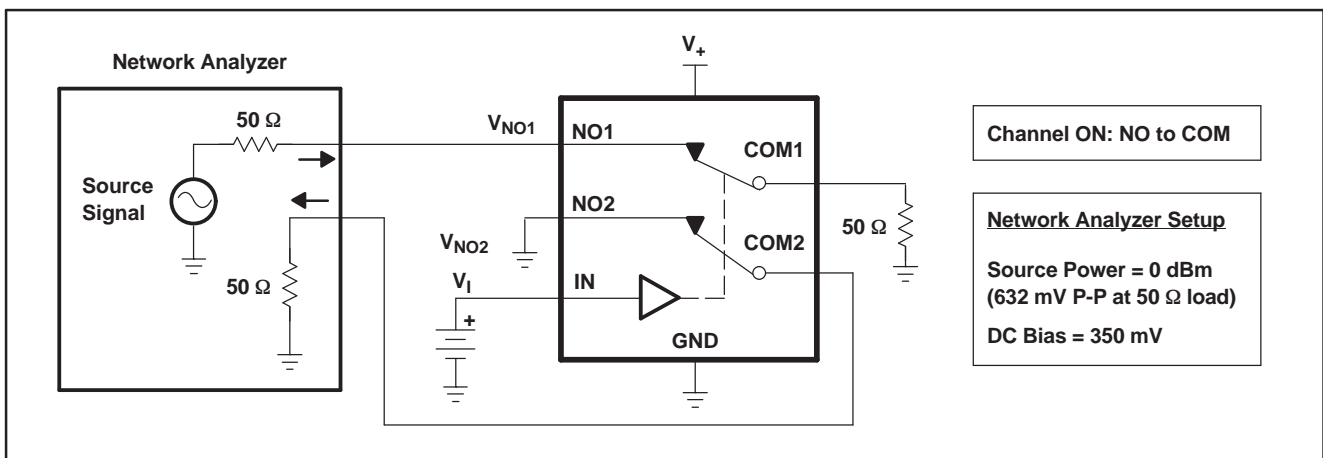

Figure 20. Crosstalk (X_{TALK})

- (4) All input pulses are supplied by generators having the following characteristics: $PRR \leq 10$ MHz, $Z_O = 50 \Omega$, $t_r < 5$ ns, $t_f < 5$ ns.
- (5) C_L includes probe and jig capacitance.

PARAMETER MEASUREMENT INFORMATION (continued)

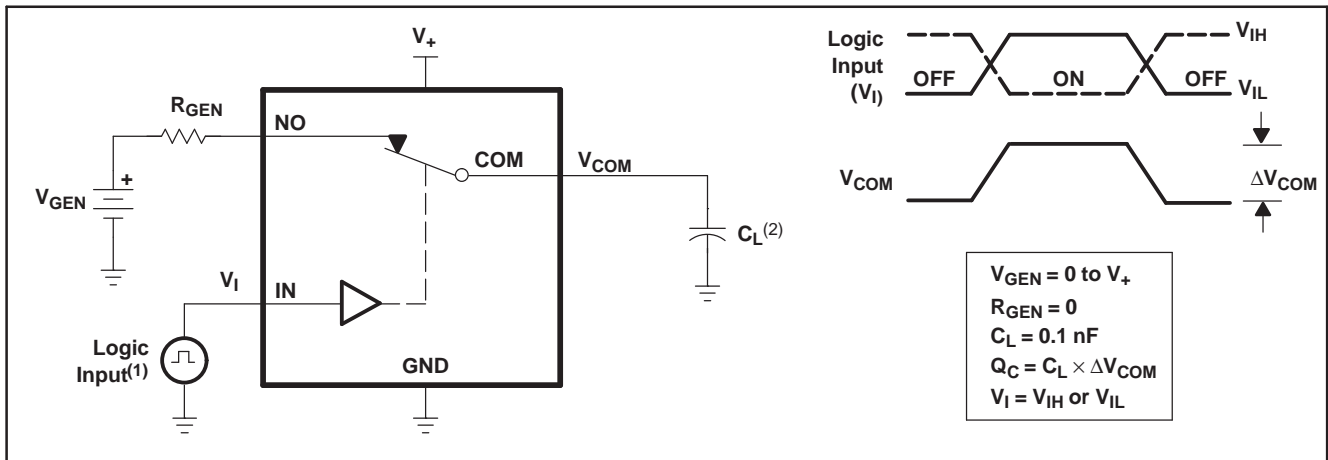

Figure 21. Charge Injection (Q_C)

(6) C_L includes probe and jig capacitance.

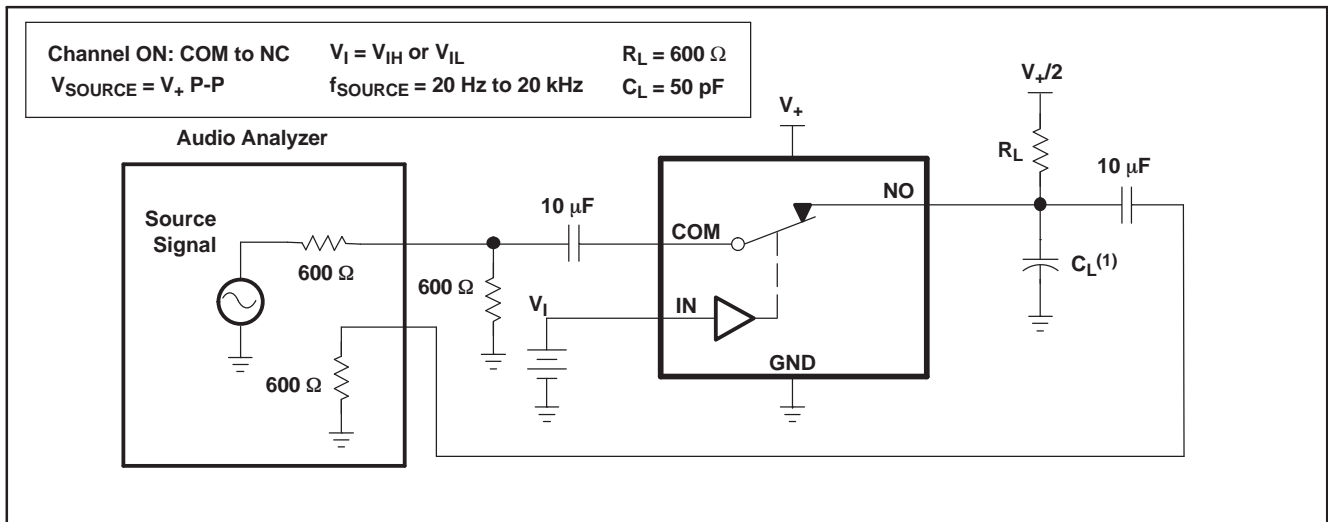

Figure 22. Total Harmonic Distortion (THD)

PACKAGING INFORMATION

Orderable Device	Status ⁽¹⁾	Package Type	Package Drawing	Pins	Package Qty	Eco Plan ⁽²⁾	Lead/Ball Finish	MSL Peak Temp ⁽³⁾
TS5A2066DCTR	ACTIVE	SM8	DCT	8	3000	Green (RoHS & no Sb/Br)	CU NIPDAU	Level-1-260C-UNLIM
TS5A2066DCTRE4	ACTIVE	SM8	DCT	8	3000	Green (RoHS & no Sb/Br)	CU NIPDAU	Level-1-260C-UNLIM
TS5A2066DCTRG4	ACTIVE	SM8	DCT	8	3000	Green (RoHS & no Sb/Br)	CU NIPDAU	Level-1-260C-UNLIM
TS5A2066DCUR	ACTIVE	US8	DCU	8	3000	Green (RoHS & no Sb/Br)	CU NIPDAU	Level-1-260C-UNLIM
TS5A2066DCURE4	ACTIVE	US8	DCU	8	3000	Green (RoHS & no Sb/Br)	CU NIPDAU	Level-1-260C-UNLIM
TS5A2066DCURG4	ACTIVE	US8	DCU	8	3000	Green (RoHS & no Sb/Br)	CU NIPDAU	Level-1-260C-UNLIM
TS5A2066YZPR	ACTIVE	DSBGA	YZP	8	3000	Green (RoHS & no Sb/Br)	SNAGCU	Level-1-260C-UNLIM

⁽¹⁾ The marketing status values are defined as follows:

ACTIVE: Product device recommended for new designs.

LIFEBUY: TI has announced that the device will be discontinued, and a lifetime-buy period is in effect.

NRND: Not recommended for new designs. Device is in production to support existing customers, but TI does not recommend using this part in a new design.

PREVIEW: Device has been announced but is not in production. Samples may or may not be available.

OBSELETE: TI has discontinued the production of the device.

⁽²⁾ Eco Plan - The planned eco-friendly classification: Pb-Free (RoHS), Pb-Free (RoHS Exempt), or Green (RoHS & no Sb/Br) - please check <http://www.ti.com/productcontent> for the latest availability information and additional product content details.

TBD: The Pb-Free/Green conversion plan has not been defined.

Pb-Free (RoHS): TI's terms "Lead-Free" or "Pb-Free" mean semiconductor products that are compatible with the current RoHS requirements for all 6 substances, including the requirement that lead not exceed 0.1% by weight in homogeneous materials. Where designed to be soldered at high temperatures, TI Pb-Free products are suitable for use in specified lead-free processes.

Pb-Free (RoHS Exempt): This component has a RoHS exemption for either 1) lead-based flip-chip solder bumps used between the die and package, or 2) lead-based die adhesive used between the die and leadframe. The component is otherwise considered Pb-Free (RoHS compatible) as defined above.

Green (RoHS & no Sb/Br): TI defines "Green" to mean Pb-Free (RoHS compatible), and free of Bromine (Br) and Antimony (Sb) based flame retardants (Br or Sb do not exceed 0.1% by weight in homogeneous material)

⁽³⁾ MSL, Peak Temp. -- The Moisture Sensitivity Level rating according to the JEDEC industry standard classifications, and peak solder temperature.

Important Information and Disclaimer:The information provided on this page represents TI's knowledge and belief as of the date that it is provided. TI bases its knowledge and belief on information provided by third parties, and makes no representation or warranty as to the accuracy of such information. Efforts are underway to better integrate information from third parties. TI has taken and continues to take reasonable steps to provide representative and accurate information but may not have conducted destructive testing or chemical analysis on incoming materials and chemicals. TI and TI suppliers consider certain information to be proprietary, and thus CAS numbers and other limited information may not be available for release.

In no event shall TI's liability arising out of such information exceed the total purchase price of the TI part(s) at issue in this document sold by TI to Customer on an annual basis.

TAPE AND REEL INFORMATION
REEL DIMENSIONS

TAPE DIMENSIONS

A0	Dimension designed to accommodate the component width
B0	Dimension designed to accommodate the component length
K0	Dimension designed to accommodate the component thickness
W	Overall width of the carrier tape
P1	Pitch between successive cavity centers

TAPE AND REEL INFORMATION

*All dimensions are nominal

Device	Package Type	Package Drawing	Pins	SPQ	Reel Diameter (mm)	Reel Width W1 (mm)	A0 (mm)	B0 (mm)	K0 (mm)	P1 (mm)	W (mm)	Pin1 Quadrant
TS5A2066DCUR	US8	DCU	8	3000	180.0	8.4	2.25	3.35	1.05	4.0	8.0	Q3
TS5A2066YZPR	DSBGA	YZP	8	3000	180.0	8.4	1.02	2.02	0.63	4.0	8.0	Q1
TS5A2066YZPR	DSBGA	YZP	8	3000	178.0	9.2	1.02	2.02	0.63	4.0	8.0	Q1

TAPE AND REEL BOX DIMENSIONS

*All dimensions are nominal

Device	Package Type	Package Drawing	Pins	SPQ	Length (mm)	Width (mm)	Height (mm)
TS5A2066DCUR	US8	DCU	8	3000	202.0	201.0	28.0
TS5A2066YZPR	DSBGA	YZP	8	3000	220.0	220.0	34.0
TS5A2066YZPR	DSBGA	YZP	8	3000	220.0	220.0	35.0

DCT (R-PDSO-G8)

PLASTIC SMALL-OUTLINE PACKAGE

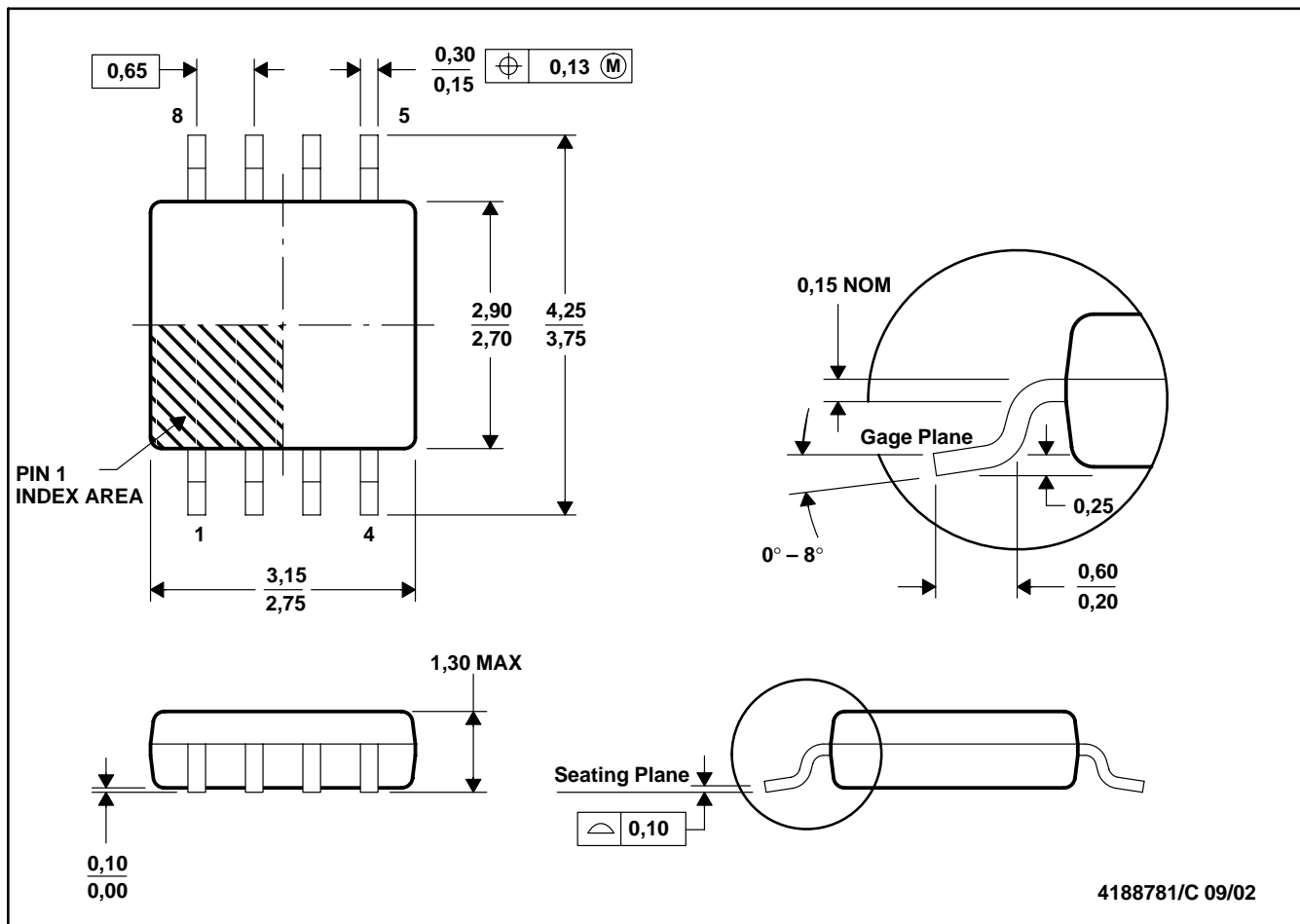

4188781/C 09/02

- NOTES:
- A. All linear dimensions are in millimeters.
 - B. This drawing is subject to change without notice.
 - C. Body dimensions do not include mold flash or protrusion
 - D. Falls within JEDEC MO-187 variation DA.

DCT (R-PDSO-G8)

PLASTIC SMALL OUTLINE

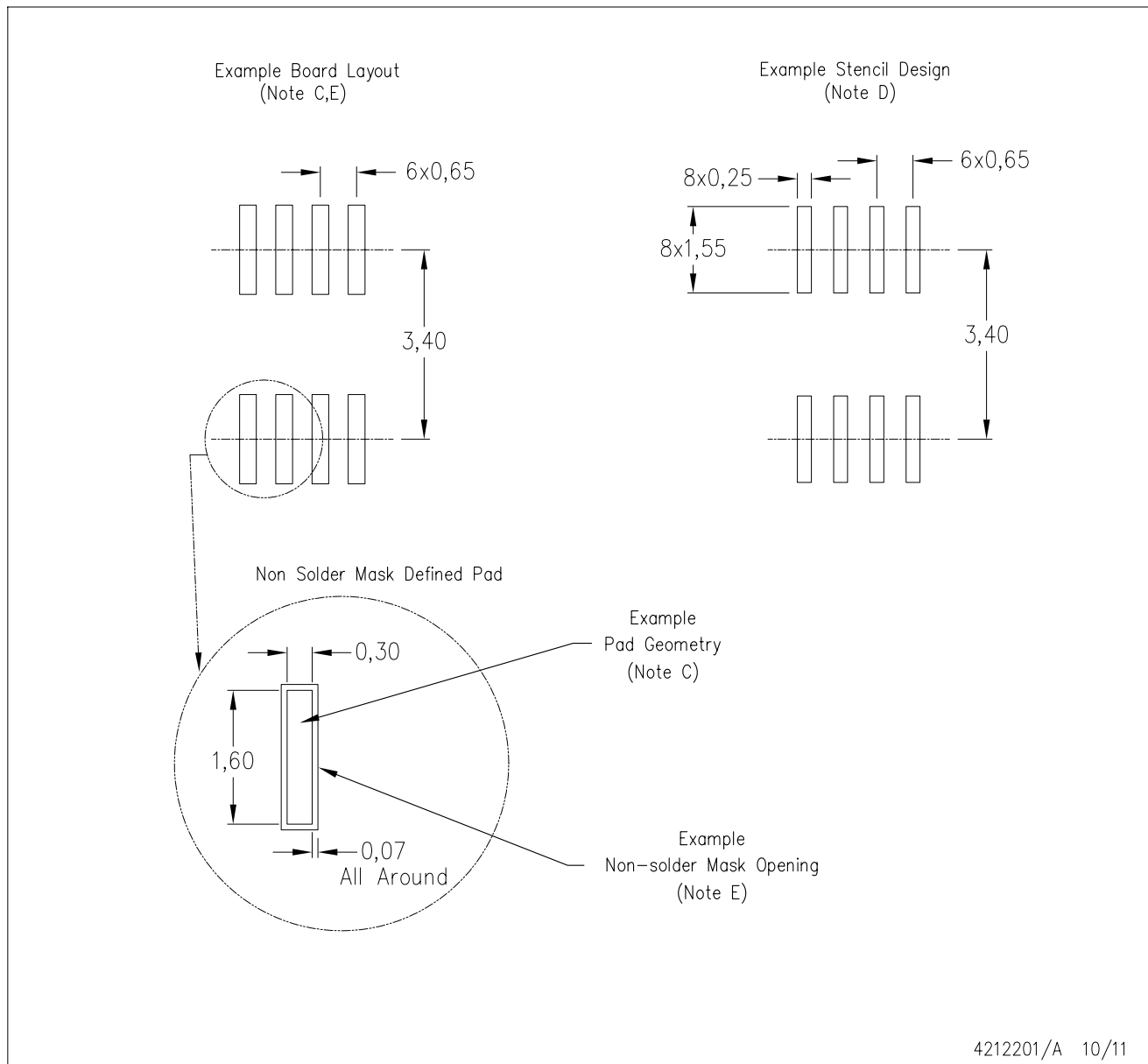

- NOTES:
- A. All linear dimensions are in millimeters.
 - B. This drawing is subject to change without notice.
 - C. Publication IPC-7351 is recommended for alternate designs.
 - D. Laser cutting apertures with trapezoidal walls and also rounding corners will offer better paste release. Customers should contact their board assembly site for stencil design recommendations. Refer to IPC-7525.
 - E. Customers should contact their board fabrication site for solder mask tolerances between and around signal pads.

DCU (S-PDSO-G8)

PLASTIC SMALL OUTLINE PACKAGE (DIE DOWN)

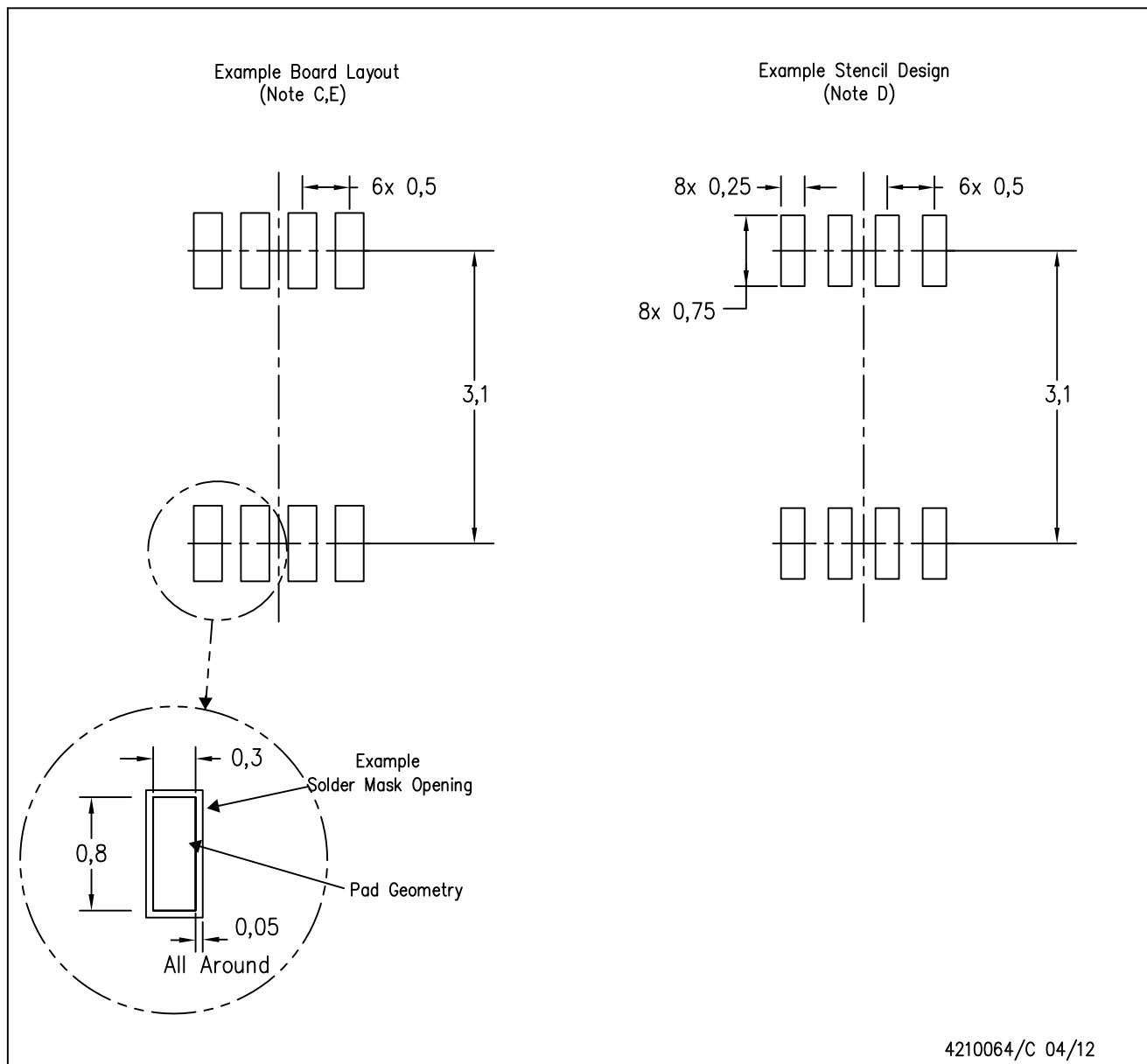

- NOTES:
- A. All linear dimensions are in millimeters.
 - B. This drawing is subject to change without notice.
 - C. Publication IPC-7351 is recommended for alternate designs.
 - D. Laser cutting apertures with trapezoidal walls and also rounding corners will offer better paste release. Customers should contact their board assembly site for stencil design recommendations. Refer to IPC-7525 for other stencil recommendations.
 - E. Customers should contact their board fabrication site for solder mask tolerances between and around signal pads.

YZP (R-XBGA-N8)

DIE-SIZE BALL GRID ARRAY

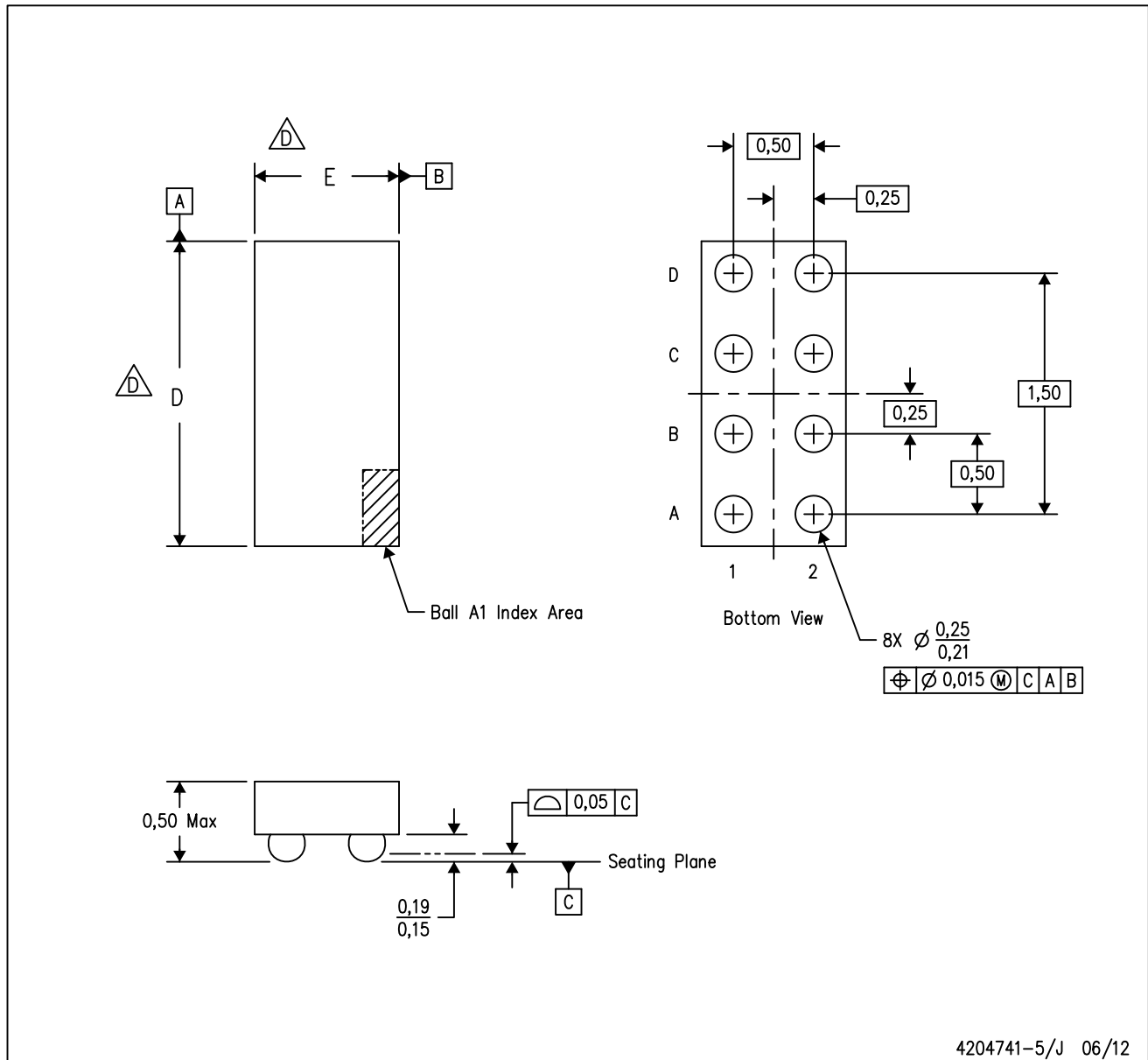

- NOTES:
- A. All linear dimensions are in millimeters. Dimensioning and tolerancing per ASME Y14.5M-1994.
 - B. This drawing is subject to change without notice.
 - C. NanoFree™ package configuration.
 - \triangle The package size (Dimension D and E) of a particular device is specified in the device Product Data Sheet version of this drawing, in case it cannot be found in the product data sheet please contact a local TI representative.
 - E. This package is a Pb-free solder ball design. Refer to the 8 YEP package (drawing 4204725) for tin-lead (SnPb).

NanoFree is a trademark of Texas Instruments.

IMPORTANT NOTICE

Texas Instruments Incorporated and its subsidiaries (TI) reserve the right to make corrections, modifications, enhancements, improvements, and other changes to its products and services at any time and to discontinue any product or service without notice. Customers should obtain the latest relevant information before placing orders and should verify that such information is current and complete. All products are sold subject to TI's terms and conditions of sale supplied at the time of order acknowledgment.

TI warrants performance of its hardware products to the specifications applicable at the time of sale in accordance with TI's standard warranty. Testing and other quality control techniques are used to the extent TI deems necessary to support this warranty. Except where mandated by government requirements, testing of all parameters of each product is not necessarily performed.

TI assumes no liability for applications assistance or customer product design. Customers are responsible for their products and applications using TI components. To minimize the risks associated with customer products and applications, customers should provide adequate design and operating safeguards.

TI does not warrant or represent that any license, either express or implied, is granted under any TI patent right, copyright, mask work right, or other TI intellectual property right relating to any combination, machine, or process in which TI products or services are used. Information published by TI regarding third-party products or services does not constitute a license from TI to use such products or services or a warranty or endorsement thereof. Use of such information may require a license from a third party under the patents or other intellectual property of the third party, or a license from TI under the patents or other intellectual property of TI.

Reproduction of TI information in TI data books or data sheets is permissible only if reproduction is without alteration and is accompanied by all associated warranties, conditions, limitations, and notices. Reproduction of this information with alteration is an unfair and deceptive business practice. TI is not responsible or liable for such altered documentation. Information of third parties may be subject to additional restrictions.

Resale of TI products or services with statements different from or beyond the parameters stated by TI for that product or service voids all express and any implied warranties for the associated TI product or service and is an unfair and deceptive business practice. TI is not responsible or liable for any such statements.

TI products are not authorized for use in safety-critical applications (such as life support) where a failure of the TI product would reasonably be expected to cause severe personal injury or death, unless officers of the parties have executed an agreement specifically governing such use. Buyers represent that they have all necessary expertise in the safety and regulatory ramifications of their applications, and acknowledge and agree that they are solely responsible for all legal, regulatory and safety-related requirements concerning their products and any use of TI products in such safety-critical applications, notwithstanding any applications-related information or support that may be provided by TI. Further, Buyers must fully indemnify TI and its representatives against any damages arising out of the use of TI products in such safety-critical applications.

TI products are neither designed nor intended for use in military/aerospace applications or environments unless the TI products are specifically designated by TI as military-grade or "enhanced plastic." Only products designated by TI as military-grade meet military specifications. Buyers acknowledge and agree that any such use of TI products which TI has not designated as military-grade is solely at the Buyer's risk, and that they are solely responsible for compliance with all legal and regulatory requirements in connection with such use.

TI products are neither designed nor intended for use in automotive applications or environments unless the specific TI products are designated by TI as compliant with ISO/TS 16949 requirements. Buyers acknowledge and agree that, if they use any non-designated products in automotive applications, TI will not be responsible for any failure to meet such requirements.

Following are URLs where you can obtain information on other Texas Instruments products and application solutions:

Products

Audio	www.ti.com/audio
Amplifiers	amplifier.ti.com
Data Converters	dataconverter.ti.com
DLP® Products	www.dlp.com
DSP	dsp.ti.com
Clocks and Timers	www.ti.com/clocks
Interface	interface.ti.com
Logic	logic.ti.com
Power Mgmt	power.ti.com
Microcontrollers	microcontroller.ti.com
RFID	www.ti-rfid.com
OMAP Mobile Processors	www.ti.com/omap
Wireless Connectivity	www.ti.com/wirelessconnectivity

Applications

Automotive and Transportation	www.ti.com/automotive
Communications and Telecom	www.ti.com/communications
Computers and Peripherals	www.ti.com/computers
Consumer Electronics	www.ti.com/consumer-apps
Energy and Lighting	www.ti.com/energy
Industrial	www.ti.com/industrial
Medical	www.ti.com/medical
Security	www.ti.com/security
Space, Avionics and Defense	www.ti.com/space-avionics-defense
Video and Imaging	www.ti.com/video

TI E2E Community Home Page

e2e.ti.com

Mailing Address: Texas Instruments, Post Office Box 655303, Dallas, Texas 75265
Copyright © 2012, Texas Instruments Incorporated