

## IEC LEVEL 4 ESD-PROTECTED 0.75-Ω SPDT ANALOG SWITCH WITH 1.8-V COMPATIBLE INPUT LOGIC

Check for Samples: [TS5A12301E](#)

### FEATURES

- Low ON-State Resistance (0.75 Ω)
- Low Charge Injection
- Excellent ON-State Resistance Matching
- Isolation in Power-Down Mode,  $V_{+} = 0$
- Specified Break-Before-Make Switching
- 2.25-V to 5.5-V Power Supply ( $V_{+}$ )
- 6-MΩ Input Pulldown Allows Control Input (IN) to Be Unconnected
- 1.8-V Compatible Control Input Threshold Independent of  $V_{+}$
- Latch-Up Performance Exceeds 100 mA Per JESD 78, Class II
- ESD Performance Tested Per JESD 22
  - 3000-V Human-Body Model (A114-B, Class II)
  - 1000-V Charged-Device Model (C101)
- ESD Performance COM Port to GND
  - 8000-V Human-Body Model (A114-B, Class II)
  - ±8-kV Contact Discharge (IEC 61000-4-2)
  - ±15-kV Air-Gap Discharge (IEC 61000-4-2)

### APPLICATIONS

- Cell Phones
- PDAs
- Portable Instrumentation
- MP3 Players
- Portable Media Players

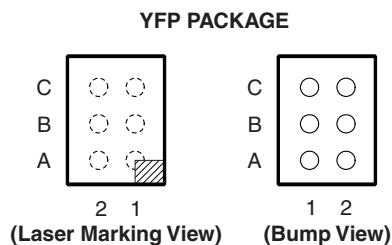

**Table 1. TERMINAL ASSIGNMENTS**

<b>C</b>	$V_{+}$	NC
<b>B</b>	COM	GND
<b>A</b>	IN	NO
	<b>2</b>	<b>1</b>

### DESCRIPTION/ORDERING INFORMATION

The TS5A12301E is a single-pole double-throw (SPDT) analog switch that is designed to operate from 2.25 V to 5.5 V. The device offers a low ON-state resistance with an excellent channel-to-channel ON-state resistance matching, and the break-before-make feature to prevent signal distortion during the transferring of a signal from one path to another.

The device has excellent total harmonic distortion (THD) performance and consumes very low power. These features make this device suitable for portable audio applications. The control input (IN) pin can be connected to low-voltage GPIOs, allowing it to be controlled by 1.8-V signals.

The TS5A12301E has ±15-kV Air-Gap Discharge and ±8-kV Contact Discharge ESD protection for the COM port to GND, which make it compliant with the IEC Level 4 ESD standard (IEC 61000-4-2).



Please be aware that an important notice concerning availability, standard warranty, and use in critical applications of Texas Instruments semiconductor products and disclaimers thereto appears at the end of this data sheet.

**Table 2. ORDERING INFORMATION<sup>(1)</sup>**

T <sub>A</sub>	PACKAGE <sup>(2)</sup>		ORDERABLE PART NUMBER	TOP-SIDE MARKING <sup>(3)</sup>
-40°C to 85°C	WCSP (DSBGA) 0.4-mm Pitch – YFP (Pb-free)	Tape and reel	TS5A12301EYFPR	___ 3W_

- (1) For the most current package and ordering information, see the Package Option Addendum at the end of this document, or see the TI website at [www.ti.com](http://www.ti.com).
- (2) Package drawings, thermal data, and symbolization are available at [www.ti.com/packaging](http://www.ti.com/packaging).
- (3) YFP: The actual top-side marking has three preceding characters to denote year, month, and sequence code, and one following character to designate the wafer fab/assembly site. Pin 1 identifier indicates solder-bump composition (1 = SnPb, • = Pb-free).

**SUMMARY OF CHARACTERISTICS<sup>(1)</sup>**

Configuration	2:1 Multiplexer/Demultiplexer (1 × SPDT)
Number of channels	1
ON-state resistance (r <sub>on</sub> )	0.75 Ω max
ON-state resistance match (Δr <sub>on</sub> )	0.1 Ω max
ON-state resistance flatness (r <sub>on(flat)</sub> )	0.1 Ω max
Turn-on/turn-off time (t <sub>ON</sub> /t <sub>OFF</sub> )	110 ns/100 ns
Break-before-make time (t <sub>BBM</sub> )	10 ns
Charge injection (Q <sub>C</sub> )	97 pC
Bandwidth (BW)	55 MHz
OFF isolation (O <sub>ISO</sub> )	-63 dB at 1 MHz
Crosstalk (X <sub>TALK</sub> )	-63 dB at 1 MHz
Total harmonic distortion (THD)	0.003%
Leakage current (I <sub>NO(OFF)</sub> /I <sub>NC(OFF)</sub> )	20 nA
Package option	6-pin WCSP, 0.4-mm pitch

(1) V<sub>+</sub> = 5 V, T<sub>A</sub> = 25°C

**FUNCTION TABLE**

IN	NC TO COM, COM TO NC	NO TO COM, COM TO NO
L or Open	ON	OFF
H	OFF	ON

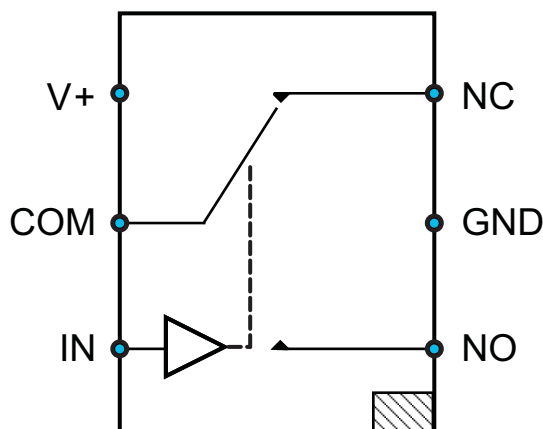

**Figure 1. Logic Diagram**

**ABSOLUTE MAXIMUM RATINGS<sup>(1) (2)</sup>**

over operating free-air temperature range (unless otherwise noted)

		MIN	MAX	UNIT
$V_+$	Supply voltage range <sup>(3)</sup>	-0.5	6.5	V
$V_{NC}$ $V_{NO}$ $V_{COM}$	Analog voltage range <sup>(3) (4) (5)</sup>	-0.5	$V_+ + 0.5$	V
$I_{IK}$	Analog port diode current	$V_+ < V_{NC}, V_{NO}, V_{COM}$ or $V_{NC}, V_{NO}, V_{COM} < 0$		mA
$I_{NC}$ $I_{NO}$ $I_{COM}$	On-state switch current	-450	450	mA
	On-state peak switch current <sup>(6)</sup>	-700	700	
$V_I$	Digital input voltage range <sup>(3) (4)</sup>	-0.5	6.5	V
$I_{IK}$	Digital input clamp current	$V_I < 0$		mA
$I_+$ $I_{GND}$	Continuous current through $V_+$ or GND	-100	100	mA
$T_{stg}$	Storage temperature range	-65	150	°C

- (1) Stresses beyond those listed under "absolute maximum ratings" may cause permanent damage to the device. These are stress ratings only, and functional operation of the device at these or any other conditions beyond those indicated under "recommended operating conditions" is not implied. Exposure to absolute-maximum-rated conditions for extended periods may affect device reliability.
- (2) The algebraic convention, whereby the most negative value is a minimum and the most positive value is a maximum
- (3) All voltages are with respect to ground, unless otherwise specified.
- (4) The input and output voltage ratings may be exceeded if the input and output clamp-current ratings are observed.
- (5) This value is limited to 5.5 V maximum.
- (6) Pulse at 1-ms duration < 10% duty cycle

**THERMAL IMPEDANCE RATINGS**

			UNIT
$\theta_{JA}$	Package thermal impedance <sup>(1)</sup>	YFP package	154.2 °C/W

- (1) The package thermal impedance is calculated in accordance with JESD 51-7.

**ELECTRICAL CHARACTERISTICS FOR 5-V SUPPLY<sup>(1)</sup>**
 $V_+ = 4.5\text{ V to }5.5\text{ V}$ ,  $T_A = -40^\circ\text{C to }85^\circ\text{C}$  (unless otherwise noted)

PARAMETER	SYMBOL	TEST CONDITIONS	$T_A$	$V_+$	MIN	TYP	MAX	UNIT	
<b>Analog Switch</b>									
Analog signal range	$V_{COM}, V_{NO}, V_{NC}$				0		$V_+$	V	
ON-state resistance	$r_{on}$	$V_{NO}$ or $V_{NC} = 2.5\text{ V}$ , $I_{COM} = -100\text{ mA}$ , See Figure 15	25°C Full	4.5 V		0.5	0.75 0.8	$\Omega$	
ON-state resistance match between channels	$\Delta r_{on}$	$V_{NO}$ or $V_{NC} = 2.5\text{ V}$ , $I_{COM} = -100\text{ mA}$ , See Figure 15	25°C Full	4.5 V		0.05	0.1 0.1	$\Omega$	
ON-state resistance flatness	$r_{on(flat)}$	$0 \leq (V_{NO} \text{ or } V_{NC}) \leq V_+$ , $I_{COM} = -100\text{ mA}$ , See Figure 15	25°C	4.5 V		0.15		$\Omega$	
		$V_{NO}$ or $V_{NC} = 1\text{ V}, 1.5\text{ V}, 2.5\text{ V}$ , $I_{COM} = -100\text{ mA}$ , See Figure 15	25°C Full			0.1 0.25			
NO, NC OFF leakage current	$I_{NO(OFF)}, I_{NC(OFF)}$	$V_{NO} = 1\text{ V}, 4.5\text{ V}$ , $V_{COM} = 4.5\text{ V}, 1\text{ V}$ , $V_{NC} = \text{Open}$ , or $V_{NO} = 1\text{ V}, 4.5\text{ V}$ , $V_{COM} = 4.5\text{ V}, 1\text{ V}$ , $V_{NC} = \text{Open}$ , See Figure 16	25°C	5.5 V		-20	2	20	nA
			Full			-100		100	
	$I_{NO(PWROFF)}, I_{NC(PWROFF)}$	$V_{NO}$ or $V_{NC} = 0$ to $5.5\text{ V}$ , $V_{COM} = 5.5\text{ V to }0$	25°C	0 V		-10		10	$\mu\text{A}$
			Full			-10		10	
NC, NO ON leakage current	$I_{NO(ON)}$	$V_{NO} = 1\text{ V}, 4.5\text{ V}$ , $V_{COM}, V_{NC} = \text{Open}$ , or $V_{NC} = 1\text{ V}, 4.5\text{ V}$ , $V_{COM}, V_{NO} = \text{Open}$ , See Figure 17	25°C Full	5.5 V		-20	2	20 200	nA
COM ON leakage current	$I_{COM(ON)}$	$V_{COM} = 1\text{ V}, 4.5\text{ V}$ , $V_{NO}$ and $V_{NC} = \text{Open}$ , or $V_{COM} = 1\text{ V}, 4.5\text{ V}$ , $V_{NO}$ or $V_{NC} = \text{Open}$ , See Figure 17	25°C Full	5.5 V		-20	2	20 200	nA
COM OFF leakage current	$I_{COM(PWROFF)}$	$V_{NO}$ or $V_{NC} = 0$ to $5.5\text{ V}$ , $V_{COM} = 5.5\text{ V to }0$ , See Figure 16	25°C Full	0 V		-10		10 10	$\mu\text{A}$
<b>Digital Control Input (IN)</b>									
Input logic high	$V_{IH}$		Full	5.5 V	1.05			5.5	V
Input logic low	$V_{IL}$		Full	5.5 V	0			0.65	V
Input leakage current	$I_{IH}, I_{IL}$	$V_I = 1.95\text{ V or }0$	Full	5.5 V	-0.05			0.5	$\mu\text{A}$
Input resistance	$r_{IN}$	$V_I = 1.95\text{ V}$	Full	5.5 V		6			M $\Omega$

(1) The algebraic convention, whereby the most negative value is a minimum and the most positive value is a maximum

**ELECTRICAL CHARACTERISTICS FOR 5-V SUPPLY<sup>(1)</sup> (continued)**
 $V_+ = 4.5\text{ V to }5.5\text{ V}$ ,  $T_A = -40^\circ\text{C to }85^\circ\text{C}$  (unless otherwise noted)

PARAMETER	SYMBOL	TEST CONDITIONS	$T_A$	$V_+$	MIN	TYP	MAX	UNIT	
<b>Dynamic</b>									
Turn-on time	$t_{ON}$	$V_{COM} = V_+$ , $R_L = 50\ \Omega$ ,	$C_L = 35\text{ pF}$ , See <a href="#">Figure 19</a>	25°C	5 V	110	225	ns	
				Full	4.5 V		250		
Turn-off time	$t_{OFF}$	$V_{COM} = V_+$ , $R_L = 50\ \Omega$ ,	$C_L = 35\text{ pF}$ , See <a href="#">Figure 19</a>	25°C	5 V	100	215	ns	
				Full	4.5 V		225		
Break-before-make time	$t_{BBM}$	$V_{COM} = V_+$ , $R_L = 50\ \Omega$ ,	$C_L = 35\text{ pF}$ , See <a href="#">Figure 20</a>	25°C	5 V	1	10	15	ns
				Full	4.5 V	1		20	
Charge injection	$Q_C$	$V_{GEN} = 0$ , $R_{GEN} = 0$ ,	$C_L = 1\text{ nF}$ , See <a href="#">Figure 24</a>	25°C	5 V		97	pC	
NO OFF capacitance	$C_{NO(OFF)}$	$V_{NC}$ or $V_{NO} = V_+$ or GND, Switch OFF,	See <a href="#">Figure 18</a>	25°C	5 V		28	pF	
NC, NO ON capacitance	$C_{NC(ON)}$ , $C_{NO(ON)}$	$V_{NC}$ or $V_{NO} = V_+$ or GND, Switch ON,	See <a href="#">Figure 18</a>	25°C	5 V		112	pF	
COM ON capacitance	$C_{COM(ON)}$	$V_{COM} = V_+$ or GND, Switch ON,	See <a href="#">Figure 18</a>	25°C	5 V		112	pF	
Digital input capacitance	$C_I$	$V_I = V_+$ or GND,	See <a href="#">Figure 18</a>	25°C	5 V		3	pF	
Bandwidth	BW	$R_L = 50\ \Omega$ , Switch ON,	See <a href="#">Figure 21</a>	25°C	5 V		55	MHz	
OFF isolation	$O_{ISO}$	$R_L = 50\ \Omega$ , $f = 1\text{ MHz}$ ,	See <a href="#">Figure 22</a>	25°C	5 V		-63	dB	
Crosstalk	$X_{TALK}$	$R_L = 50\ \Omega$ , $f = 1\text{ MHz}$ ,	See <a href="#">Figure 23</a>	25°C	5 V		-63	dB	
Total harmonic distortion	THD	$R_L = 600\ \Omega$ , $C_L = 50\text{ pF}$ ,	$f = 20\text{ Hz to }20\text{ kHz}$ , See <a href="#">Figure 25</a>	25°C	5 V		0.003	%	
<b>Supply</b>									
Positive supply current	$I_+$	$V_I = V_+$ or GND		Full	5.5 V		10	$\mu\text{A}$	

**ELECTRICAL CHARACTERISTICS FOR 3.3-V SUPPLY<sup>(1)</sup>**
 $V_+ = 3\text{ V to }3.6\text{ V}$ ,  $T_A = -40^\circ\text{C to }85^\circ\text{C}$  (unless otherwise noted)

PARAMETER	SYMBOL	TEST CONDITIONS	$T_A$	$V_+$	MIN	TYP	MAX	UNIT
<b>Analog Switch</b>								
Analog signal range	$V_{COM}, V_{NO}$				0		$V_+$	V
ON-state resistance	$r_{on}$	$V_{NO}$ or $V_{NC} = 2\text{ V}$ , $I_{COM} = -100\text{ mA}$ , Switch ON, See <a href="#">Figure 15</a>	25°C Full	3 V		0.75	0.9 1.2	$\Omega$
ON-state resistance match between channels	$\Delta r_{on}$	$V_{NO}$ or $V_{NC} = 2\text{ V}, 0.8\text{ V}$ , $I_{COM} = -100\text{ mA}$ , Switch ON, See <a href="#">Figure 15</a>	25°C Full	3 V		0.1	0.15 0.15	$\Omega$
ON-state resistance flatness	$r_{on(flat)}$	$0 \leq (V_{NO} \text{ or } V_{NC}) \leq V_+$ , $I_{COM} = -100\text{ mA}$ , Switch ON, See <a href="#">Figure 15</a>	25°C Full	3 V		0.2 0.1	0.2 0.2 0.3	$\Omega$
NO, NC OFF leakage current	$I_{NO(OFF)}, I_{NC(OFF)}$ $I_{NO(PWROFF)}, I_{NC(PWROFF)}$	$V_{NO} = 1\text{ V}, 3\text{ V}$ , $V_{COM} = 3\text{ V}, 1\text{ V}$ , $V_{NC} = \text{Open}$ , or $V_{NC} = 1\text{ V}, 3\text{ V}$ , $V_{COM} = 3\text{ V}, 1\text{ V}$ , $V_{NO} = \text{Open}$ , $V_{NO}$ or $V_{NC} = 0$ to $3.6\text{ V}$ , $V_{COM} = 3.6\text{ V to }0$	25°C Full	3.6 V 0 V	-20 -50 -10 -10	2 50 10 10	20	nA $\mu\text{A}$
NC, NO ON leakage current	$I_{NO(ON)}$	$V_{NO} = 1\text{ V}, 3\text{ V}$ , $V_{NC}$ and $V_{COM} = \text{Open}$ , or $V_{NC} = 1\text{ V}, 3\text{ V}$ , $V_{NO}$ and $V_{COM} = \text{Open}$ , Switch ON, See <a href="#">Figure 17</a>	25°C Full	3.6 V	-20 -100	2 100	20	nA
COM ON leakage current	$I_{COM(ON)}$	$V_{COM} = 1\text{ V}$ , $V_{NO}$ and $V_{NC} = \text{Open}$ , or $V_{COM} = 3\text{ V}$ , $V_{NO}$ and $V_{NC} = \text{Open}$ , See <a href="#">Figure 17</a>	25°C Full	3.6 V	-20 -100	2 100	20	nA
COM OFF leakage current	$I_{COM(PWROFF)}$	$V_{NO}$ or $V_{NC} = 0$ to $3.6\text{ V}$ , $V_{COM} = 3.6\text{ V to }0$ , See <a href="#">Figure 16</a>	25°C Full	0 V	-10 -10	10 10		$\mu\text{A}$
<b>Digital Control Input (IN)</b>								
Input logic high	$V_{IH}$		Full	3.6 V	1.05		5.5	V
Input logic low	$V_{IL}$		Full	3.6 V	0		0.65	V
Input leakage current	$I_{IH}, I_{IL}$	$V_I = 1.95\text{ V or }0$	Full	3.6 V	-0.05		0.5	$\mu\text{A}$
Input resistance	$r_{IN}$	$V_I = 1.95\text{ V}$	Full	3.6 V		6		M $\Omega$

(1) The algebraic convention, whereby the most negative value is a minimum and the most positive value is a maximum

**ELECTRICAL CHARACTERISTICS FOR 3.3-V SUPPLY<sup>(1)</sup> (continued)**
 $V_+ = 3\text{ V to }3.6\text{ V}$ ,  $T_A = -40^\circ\text{C to }85^\circ\text{C}$  (unless otherwise noted)

PARAMETER	SYMBOL	TEST CONDITIONS	$T_A$	$V_+$	MIN	TYP	MAX	UNIT	
<b>Dynamic</b>									
Turn-on time	$t_{ON}$	$V_{COM} = V_+$ , $R_L = 50\ \Omega$ ,	$C_L = 35\text{ pF}$ , See <a href="#">Figure 19</a>	25°C	3.3 V	72	175	ns	
				Full	3 V		185		
Turn-off time	$t_{OFF}$	$V_{COM} = V_+$ , $R_L = 50\ \Omega$ ,	$C_L = 35\text{ pF}$ , See <a href="#">Figure 19</a>	25°C	3.3 V	105	165	ns	
				Full	3 V		170		
Break-before-make time	$t_{BBM}$	$V_{COM} = V_+$ , $R_L = 50\ \Omega$ ,	$C_L = 35\text{ pF}$ , See <a href="#">Figure 20</a>	25°C	3.3 V	1	16	30	ns
				Full	3 V	1		35	
Charge injection	$Q_C$	$V_{GEN} = 0$ , $R_{GEN} = 0$ ,	$C_L = 1\text{ nF}$ , See <a href="#">Figure 24</a>	25°C	3.3V	97		pC	
NO OFF capacitance	$C_{NO(OFF)}$	$V_{NO} = V_+$ or GND, Switch OFF,	See <a href="#">Figure 18</a>	25°C	3.3 V	28		pF	
NC, NO ON capacitance	$C_{NC(ON)}$ , $C_{NO(ON)}$	$V_{NC}$ or $V_{NO} = V_+$ or GND, Switch ON,	See <a href="#">Figure 18</a>	25°C	3.3 V	115		pF	
COM ON capacitance	$C_{COM(ON)}$	$V_{COM} = V_+$ or GND, Switch ON,	See <a href="#">Figure 18</a>	25°C	3.3 V	115		pF	
Digital input capacitance	$C_I$	$V_I = V_+$ or GND,	See <a href="#">Figure 18</a>	25°C	3.3 V	3		pF	
Bandwidth	BW	$R_L = 50\ \Omega$ , Switch ON,	See <a href="#">Figure 21</a>	25°C	3.3 V	54		MHz	
OFF isolation	$O_{ISO}$	$R_L = 50\ \Omega$ , $f = 1\text{ MHz}$ ,	See <a href="#">Figure 22</a>	25°C	3.3 V	-63		dB	
Crosstalk	$X_{TALK}$	$R_L = 50\ \Omega$ , $f = 1\text{ MHz}$ ,	See <a href="#">Figure 23</a>	25°C	3.3 V	-63		dB	
Total harmonic distortion	THD	$R_L = 600\ \Omega$ , $C_L = 50\text{ pF}$ ,	$f = 20\text{ Hz to }20\text{ kHz}$ , See <a href="#">Figure 25</a>	25°C	3.3 V	0.004		%	
<b>Supply</b>									
Positive supply current	$I_+$	$V_I = 1.95\text{ V or GND}$	25°C	3.6 V			10	$\mu\text{A}$	

**ELECTRICAL CHARACTERISTICS FOR 2.5-V SUPPLY<sup>(1)</sup>**
 $V_+ = 2.25\text{ V to }2.75\text{ V}$ ,  $T_A = -40^\circ\text{C to }85^\circ\text{C}$  (unless otherwise noted)

PARAMETER	SYMBOL	TEST CONDITIONS	$T_A$	$V_+$	MIN	TYP	MAX	UNIT	
<b>Analog Switch</b>									
Analog signal range	$V_{COM}, V_{NO}$				0		$V_+$	V	
ON-state resistance	$r_{on}$	$V_{NO}$ or $V_{NC} = 1.8\text{ V}$ , $I_{COM} = -100\text{ mA}$ ,	Switch ON, See <a href="#">Figure 15</a>	25°C	2.25 V	1.1	1.3	$\Omega$	
				Full		1.6			
ON-state resistance match between channels	$\Delta r_{on}$	$V_{NO}$ or $V_{NC} = 1.8\text{ V}$ , $0.8\text{ V}$ , $I_{COM} = -100\text{ mA}$ ,	Switch ON, See <a href="#">Figure 15</a>	25°C	2.25 V	0.15	0.2	$\Omega$	
				Full		0.2			
ON-state resistance flatness	$r_{on(flat)}$	$0 \leq (V_{NO} \text{ or } V_{NC}) \leq V_+$ , $I_{COM} = -100\text{ mA}$ ,	Switch ON, See <a href="#">Figure 15</a>	25°C	2.25 V	0.4		$\Omega$	
				25°C		0.25	0.5		
				Full		0.6			
NO, NC OFF leakage current	$I_{NO(OFF)}, I_{NC(OFF)}$	$V_{NO} = 0.5\text{ V}, 2.2\text{ V}$ , $V_{COM} = 2.2\text{ V}, 0.5\text{ V}$ , $V_{NC} = \text{Open}$ , or $V_{NC} = 0.5\text{ V}, 2.2\text{ V}$ , $V_{COM} = 2.2\text{ V}, 0.5\text{ V}$ , $V_{NO} = \text{Open}$ ,	Switch OFF, See <a href="#">Figure 16</a>	25°C	2.75 V	-20	2	20	nA
				Full		-50	50		
	$I_{NO(PWROFF)}, I_{NC(PWROFF)}$	$V_{NO}$ or $V_{NC} = 0$ to $2.75\text{ V}$ , $V_{COM} = 2.75\text{ V to }0$	25°C	0 V	-10	10	$\mu\text{A}$		
NC, NO ON leakage current	$I_{NO(ON)}$	$V_{NO} = 0.5\text{ V}, 2.2\text{ V}$ , $V_{NC}$ and $V_{COM} = \text{Open}$ , or $V_{NC} = 2.2\text{ V}, 0.5\text{ V}$ , $V_{NO}$ and $V_{COM} = \text{Open}$ ,	Switch ON, See <a href="#">Figure 17</a>	25°C	2.75 V	-20	2	20	nA
				Full		-100	100		
COM ON leakage current	$I_{COM(ON)}$	$V_{COM} = 0.5\text{ V}$ , $V_{NO}$ and $V_{NC} = \text{Open}$ , or $V_{COM} = 2.2\text{ V}$ , $V_{NO}$ and $V_{NC} = \text{Open}$ ,	Switch ON, See <a href="#">Figure 17</a>	25°C	2.75 V	-20	2	20	nA
				Full		-100	100		
COM OFF leakage current	$I_{COM(PWROFF)}$	$V_{NO}$ or $V_{NC} = 0$ to $2.75\text{ V}$ , $V_{COM} = 2.75\text{ V to }0$	See <a href="#">Figure 16</a>	25°C	0 V	-10	10	$\mu\text{A}$	
				Full		-10	10		
<b>Digital Control Input (IN)</b>									
Input logic high	$V_{IH}$		Full	2.75 V	1.05		5.5	V	
Input logic low	$V_{IL}$		Full	2.75 V	0		0.65	V	
Input leakage current	$I_{IH}, I_{IL}$	$V_I = 1.95\text{ V or }0$	Full	2.75 V	-0.05		0.5	$\mu\text{A}$	
Input resistance	$r_{IN}$	$V_I = 1.95\text{ V}$	Full	2.75 V		6		$\text{M}\Omega$	

(1) The algebraic convention, whereby the most negative value is a minimum and the most positive value is a maximum

**ELECTRICAL CHARACTERISTICS FOR 2.5-V SUPPLY<sup>(1)</sup> (continued)**
 $V_+ = 2.25\text{ V to }2.75\text{ V}$ ,  $T_A = -40^\circ\text{C to }85^\circ\text{C}$  (unless otherwise noted)

PARAMETER	SYMBOL	TEST CONDITIONS	$T_A$	$V_+$	MIN	TYP	MAX	UNIT	
<b>Dynamic</b>									
Turn-on time	$t_{ON}$	$V_{COM} = V_+$ , $R_L = 50\ \Omega$ ,	$C_L = 35\text{ pF}$ , See <a href="#">Figure 19</a>	25°C	2.5 V	97	170	ns	
				Full	2.25 V		175		
Turn-off time	$t_{OFF}$	$V_{COM} = V_+$ , $R_L = 50\ \Omega$ ,	$C_L = 35\text{ pF}$ , See <a href="#">Figure 19</a>	25°C	2.5 V	80	155	ns	
				Full	2.25 V		160		
Break-before-make time	$t_{BBM}$	$V_{COM} = V_+$ , $R_L = 50\ \Omega$ ,	$C_L = 35\text{ pF}$ , See <a href="#">Figure 20</a>	25°C	2.5 V	5	18	35	ns
				Full	2.25 V	5		40	
Charge injection	$Q_C$	$V_{GEN} = 0$ , $R_{GEN} = 0$ ,	$C_L = 1\text{ nF}$ , See <a href="#">Figure 24</a>	25°C	2.5 V	82		pC	
NO OFF capacitance	$C_{NO(OFF)}$	$V_{NO} = V_+$ or GND, Switch OFF,	See <a href="#">Figure 18</a>	25°C	2.5 V	29		pF	
NC, NO ON capacitance	$C_{NC(ON)}$ , $C_{NO(ON)}$	$V_{NC}$ or $V_{NO} = V_+$ or GND, Switch ON,	See <a href="#">Figure 18</a>	25°C	2.5 V	116		pF	
COM ON capacitance	$C_{COM(ON)}$	$V_{COM} = V_+$ or GND, Switch ON,	See <a href="#">Figure 18</a>	25°C	2.5 V	116		pF	
Digital input capacitance	$C_I$	$V_I = V_+$ or GND,	See <a href="#">Figure 18</a>	25°C	2.5 V	3		pF	
Bandwidth	BW	$R_L = 50\ \Omega$ , Switch ON,	See <a href="#">Figure 21</a>	25°C	2.5 V	54		MHz	
OFF isolation	$O_{ISO}$	$R_L = 50\ \Omega$ , $f = 1\text{ MHz}$ ,	See <a href="#">Figure 22</a>	25°C	2.5 V	-63		dB	
Crosstalk	$X_{TALK}$	$R_L = 50\ \Omega$ , $f = 1\text{ MHz}$ ,	See <a href="#">Figure 23</a>	25°C	2.5 V	-63		dB	
Total harmonic distortion	THD	$R_L = 600\ \Omega$ , $C_L = 50\text{ pF}$ ,	$f = 20\text{ Hz to }20\text{ kHz}$ , See <a href="#">Figure 25</a>	25°C	2.5 V	0.008		%	
<b>Supply</b>									
Positive supply current	$I_+$	$V_I = 1.95\text{ V or GND}$	Full	2.75 V			10	$\mu\text{A}$	

TYPICAL PERFORMANCE

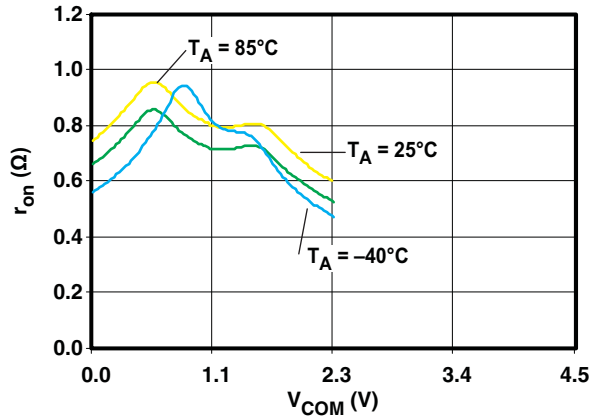

Figure 2.  $r_{on}$  vs  $V_{COM}$  ( $V_+ = 2.25$  V)

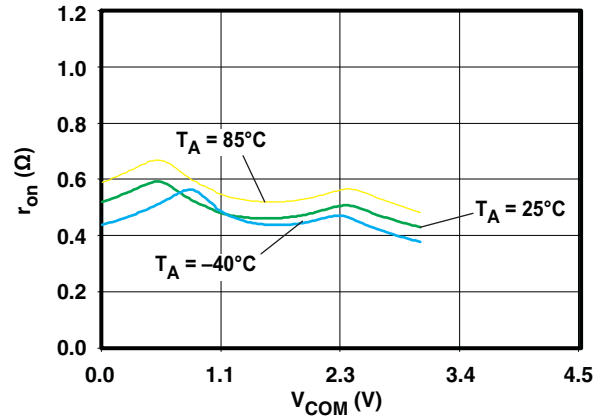

Figure 3.  $r_{on}$  vs  $V_{COM}$  ( $V_+ = 3$  V)

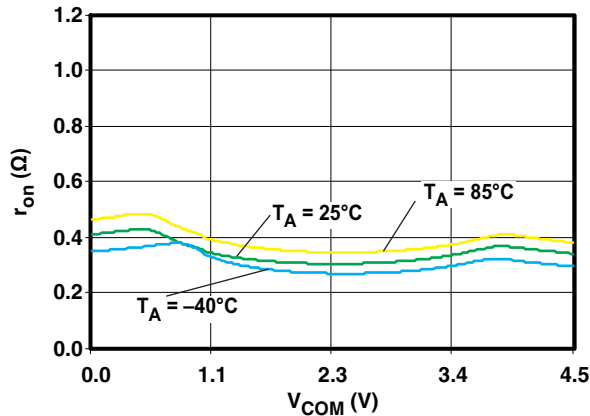

Figure 4.  $r_{on}$  vs  $V_{COM}$  ( $V_+ = 4.5$  V)

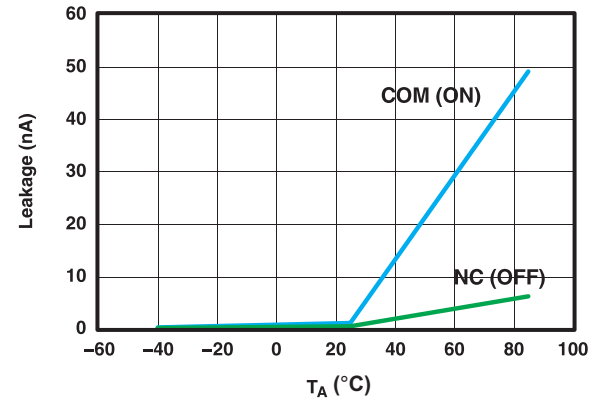

Figure 5. Leakage Current vs Temperature ( $V_+ = 5$  V)

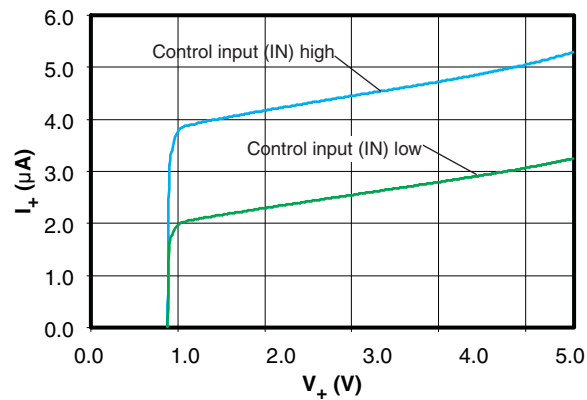

Figure 6.  $I_+$  vs  $V_+$  ( $T_A = 25^\circ\text{C}$ )

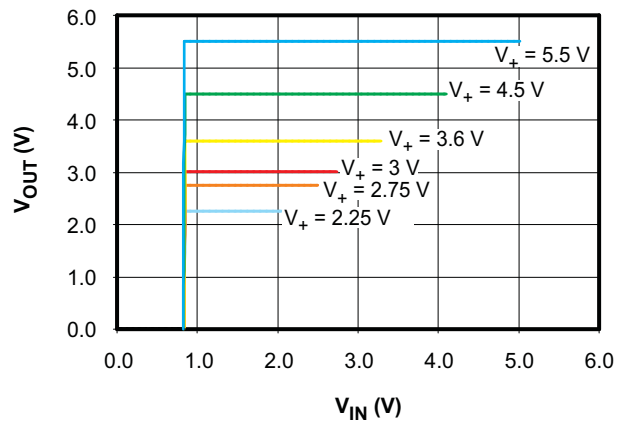

Figure 7. Control Input Thresholds

TYPICAL PERFORMANCE (continued)

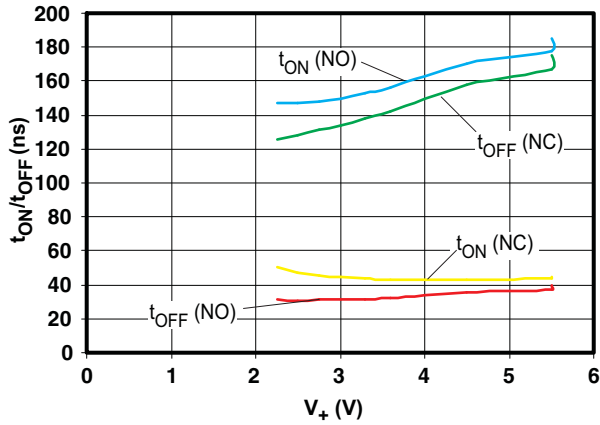

Figure 8.  $t_{ON}/t_{OFF}$  vs Supply Voltage

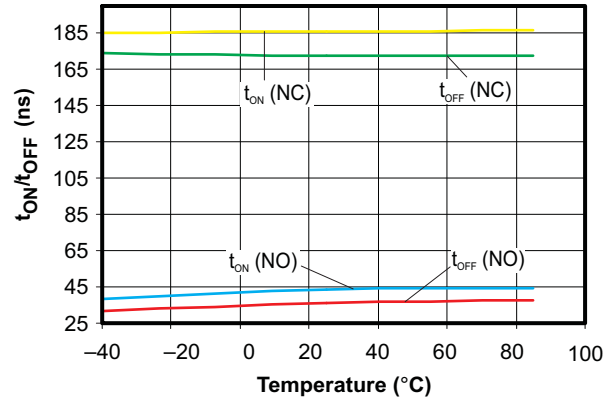

Figure 9.  $t_{ON}/t_{OFF}$  vs Temperature

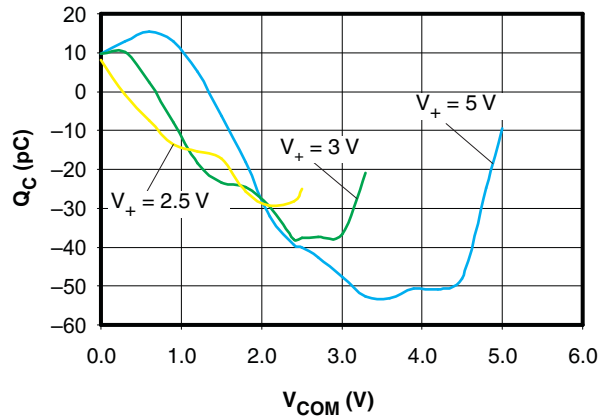

Figure 10. Charge Injection ( $Q_C$ ) vs  $V_{COM}$

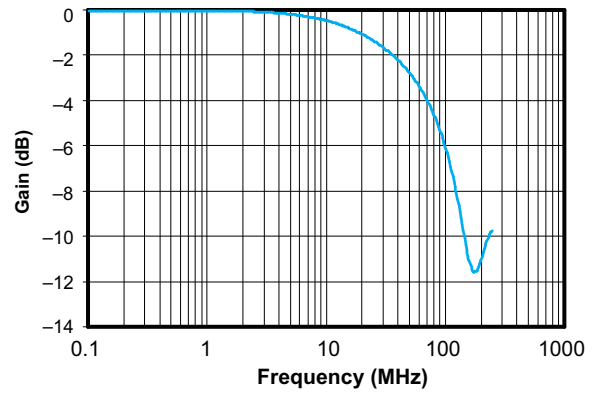

Figure 11. Gain vs Frequency

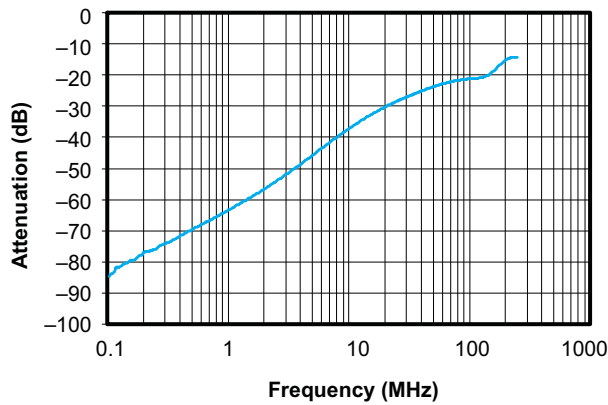

Figure 12. OFF Isolation vs Frequency

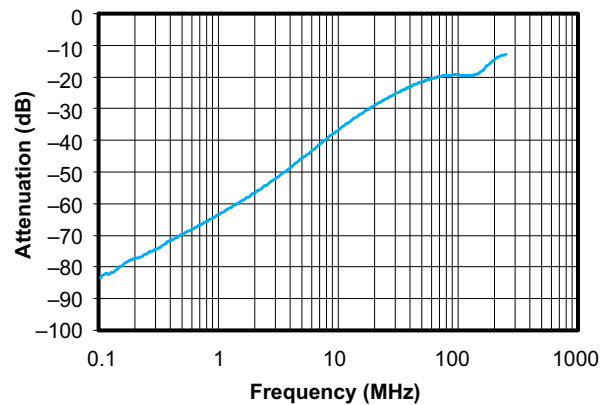
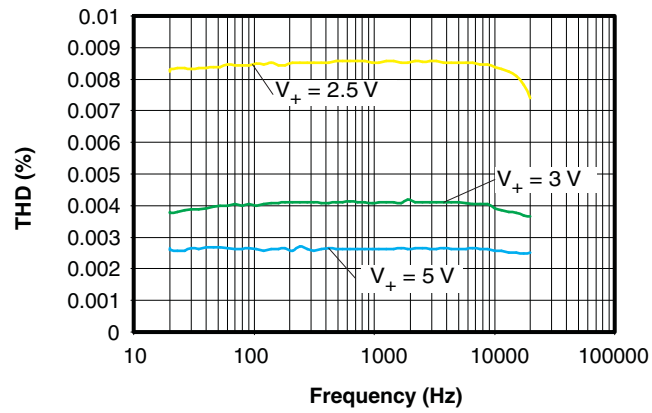

Figure 13. Crosstalk vs Frequency

**TYPICAL PERFORMANCE (continued)**



**Figure 14. Total Harmonic Distortion (THD) vs Frequency**

PARAMETER MEASUREMENT INFORMATION

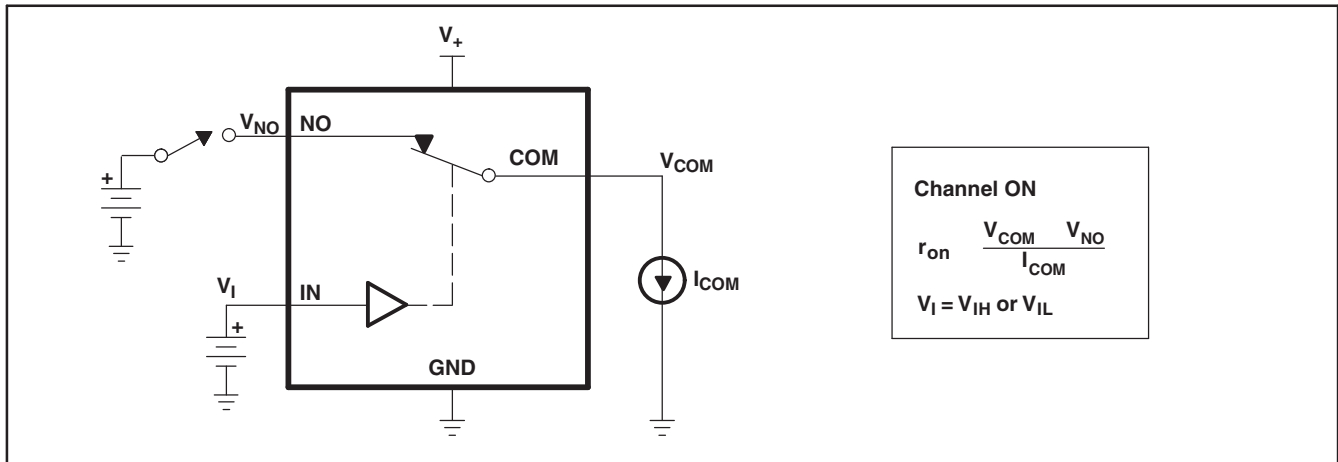

Figure 15. ON-State Resistance ( $r_{on}$ )

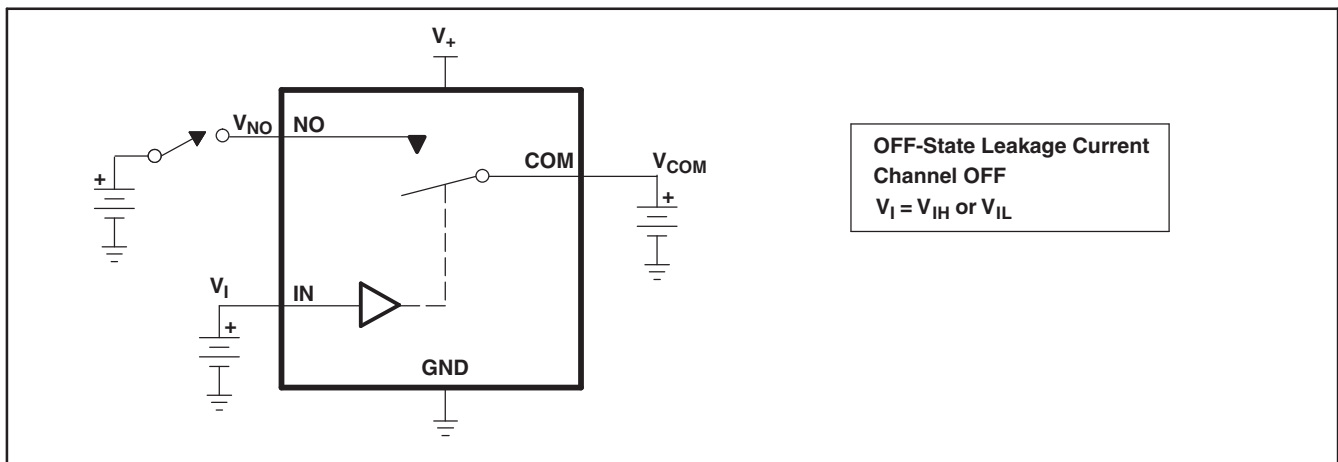

Figure 16. OFF-State Leakage Current ( $I_{COM(OFF)}$ ,  $I_{NC(OFF)}$ ,  $I_{COM(PWROFF)}$ ,  $I_{NC(PWRFF)}$ )

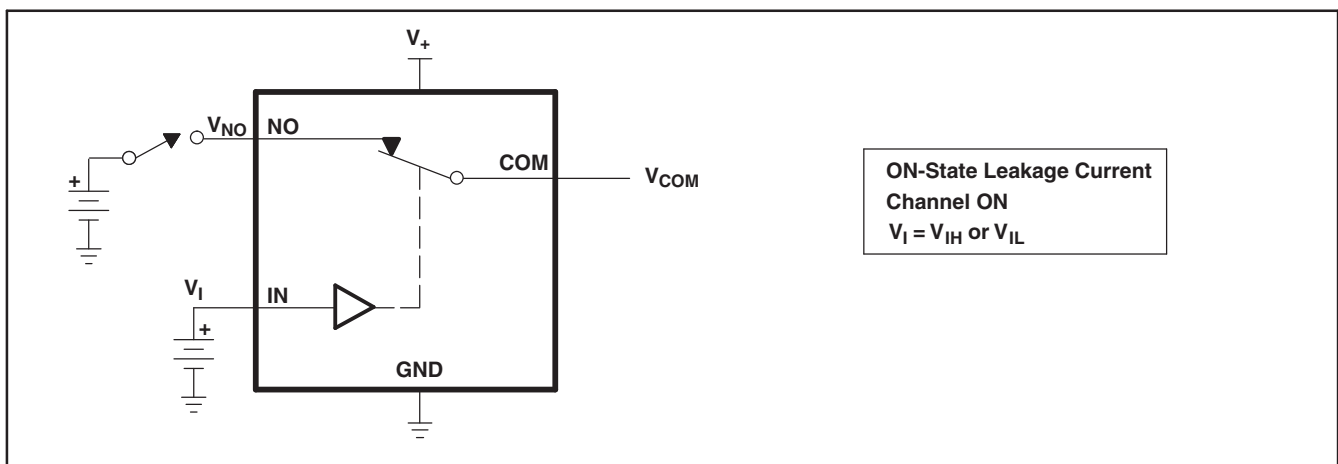
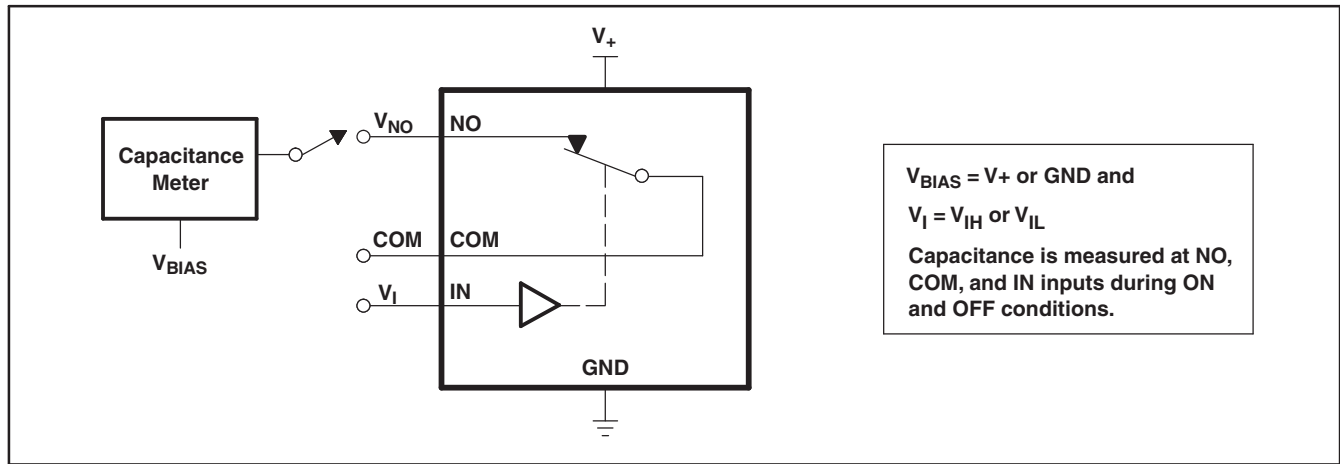
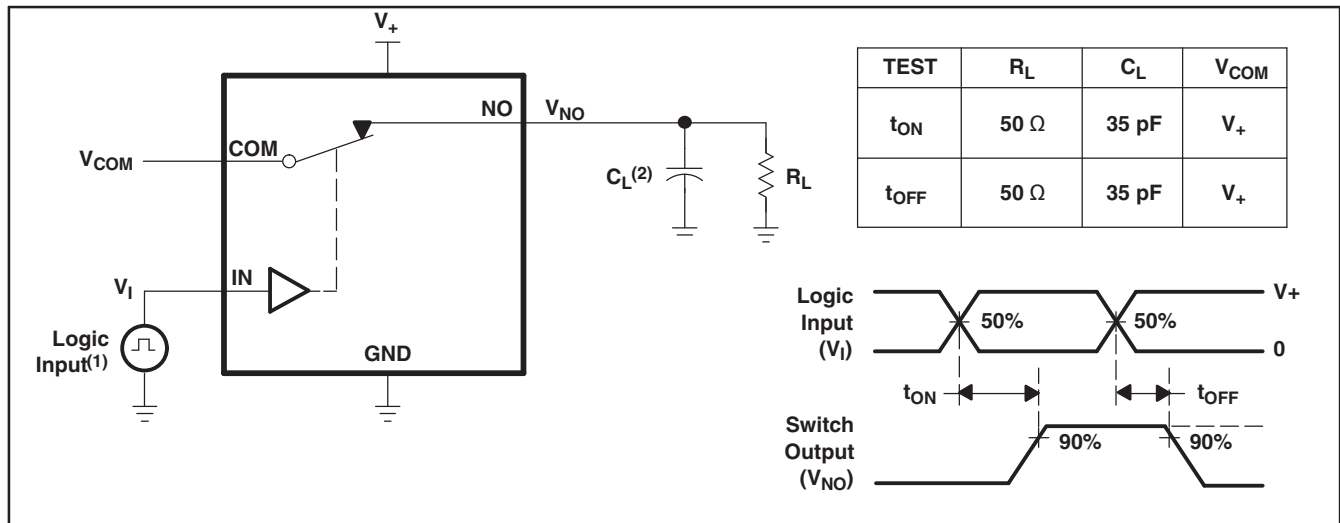

Figure 17. ON-State Leakage Current ( $I_{COM(ON)}$ ,  $I_{NC(ON)}$ )

**PARAMETER MEASUREMENT INFORMATION (continued)**



**Figure 18. Capacitance ( $C_I$ ,  $C_{COM(OFF)}$ ,  $C_{COM(ON)}$ ,  $C_{NC(OFF)}$ ,  $C_{NC(ON)}$ )**



- A. All input pulses are supplied by generators having the following characteristics:  $PRR \leq 10 \text{ MHz}$ ,  $Z_O = 50 \Omega$ ,  $t_r < 5 \text{ ns}$ ,  $t_f < 5 \text{ ns}$ .
- B.  $C_L$  includes probe and jig capacitance.

**Figure 19. Turn-On ( $t_{ON}$ ) and Turn-Off Time ( $t_{OFF}$ )**

PARAMETER MEASUREMENT INFORMATION (continued)

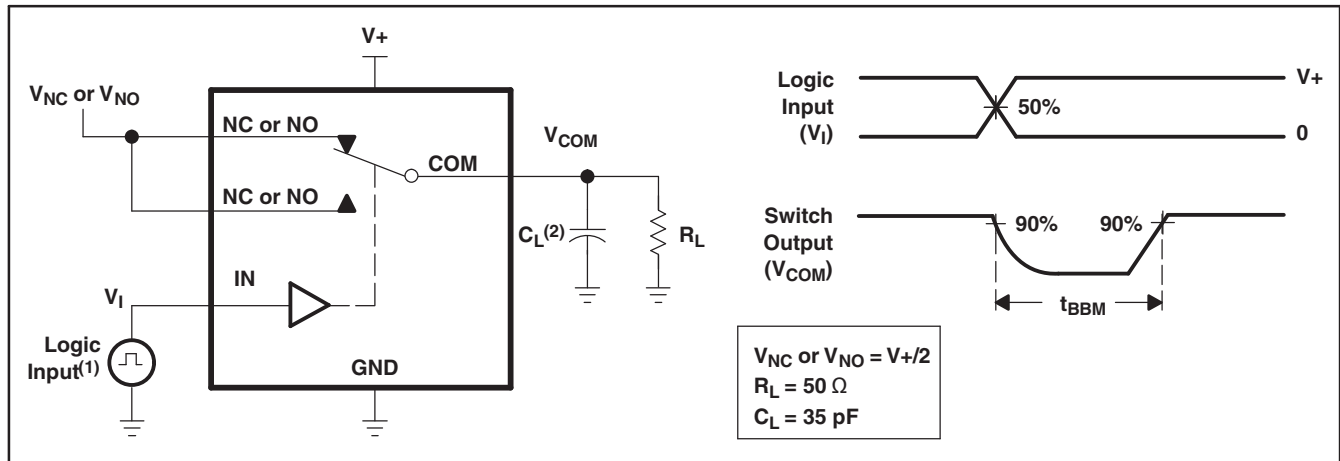

- A. All input pulses are supplied by generators having the following characteristics: PRR ≤ 10 MHz, Z<sub>O</sub> = 50 Ω, t<sub>r</sub> < 5 ns, t<sub>f</sub> < 5 ns.
- B. C<sub>L</sub> includes probe and jig capacitance.

Figure 20. Break-Before-Make Time (t<sub>BBM</sub>)

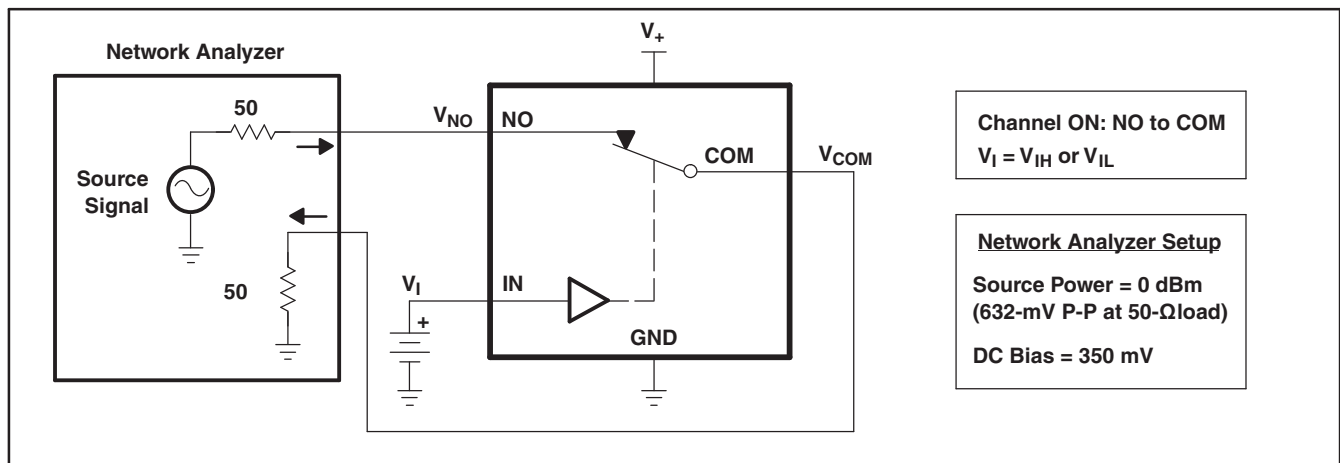
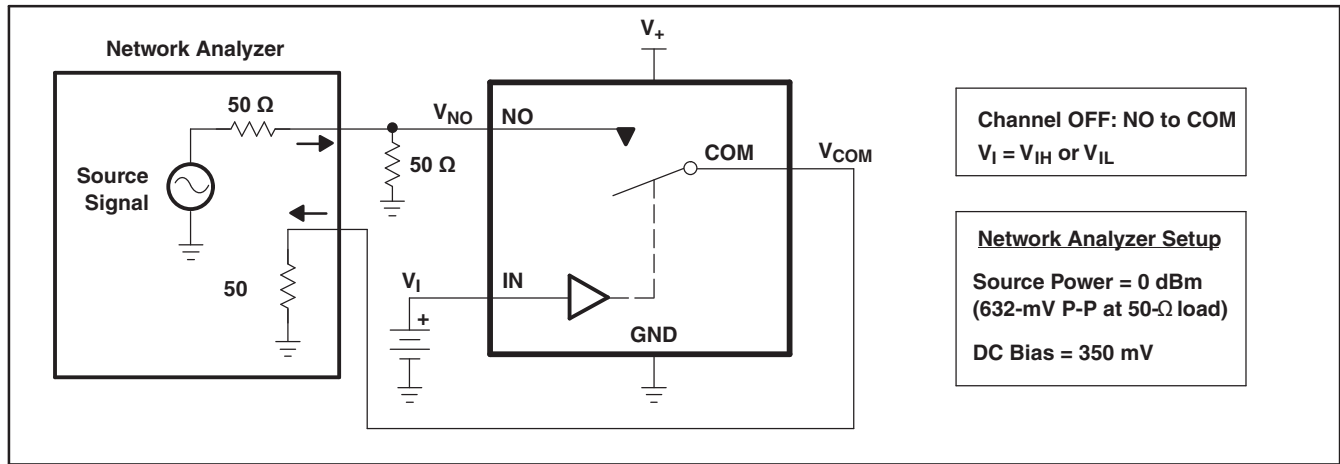
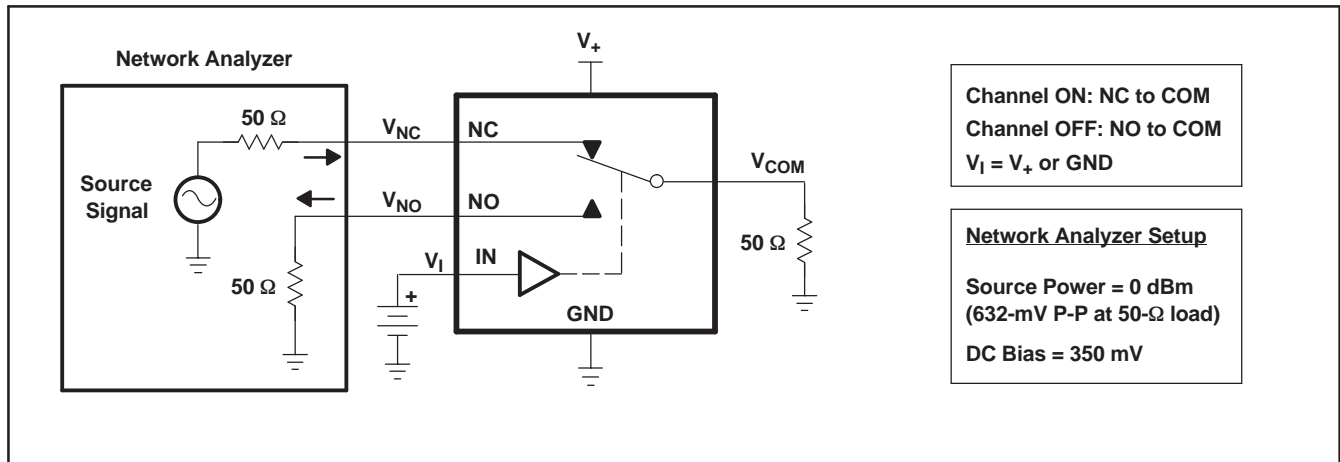

Figure 21. Bandwidth (BW)

**PARAMETER MEASUREMENT INFORMATION (continued)**

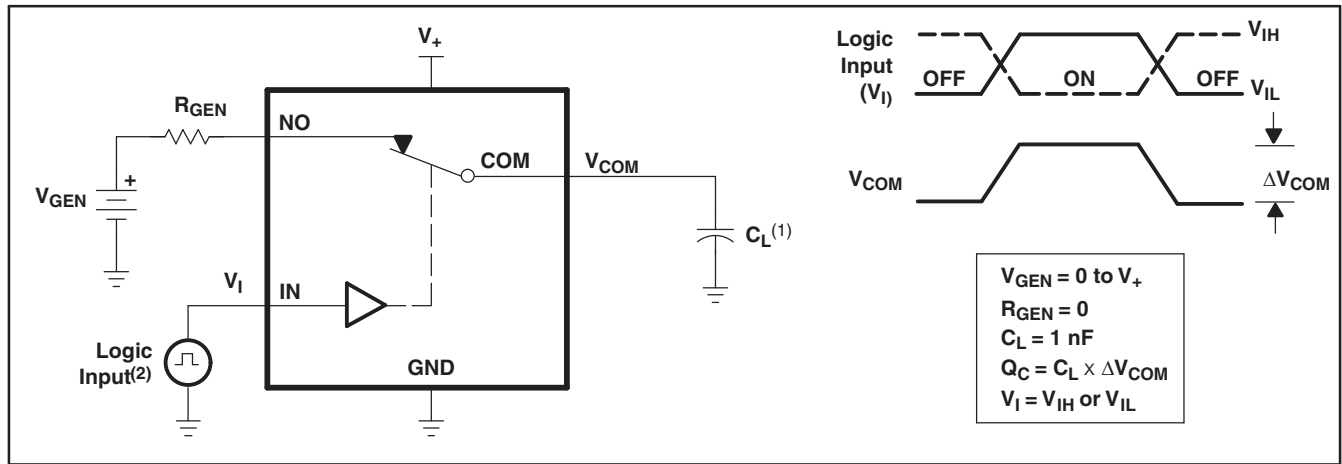

**Figure 22. OFF Isolation ( $O_{ISO}$ )**



**Figure 23. Crosstalk ( $X_{TALK}$ )**

PARAMETER MEASUREMENT INFORMATION (continued)



- A. All input pulses are supplied by generators having the following characteristics: PRR ≤ 10 MHz, Z<sub>O</sub> = 50 Ω, t<sub>r</sub> < 5 ns, t<sub>f</sub> < 5 ns.
- B. C<sub>L</sub> includes probe and jig capacitance.

Figure 24. Charge Injection (Q<sub>C</sub>)

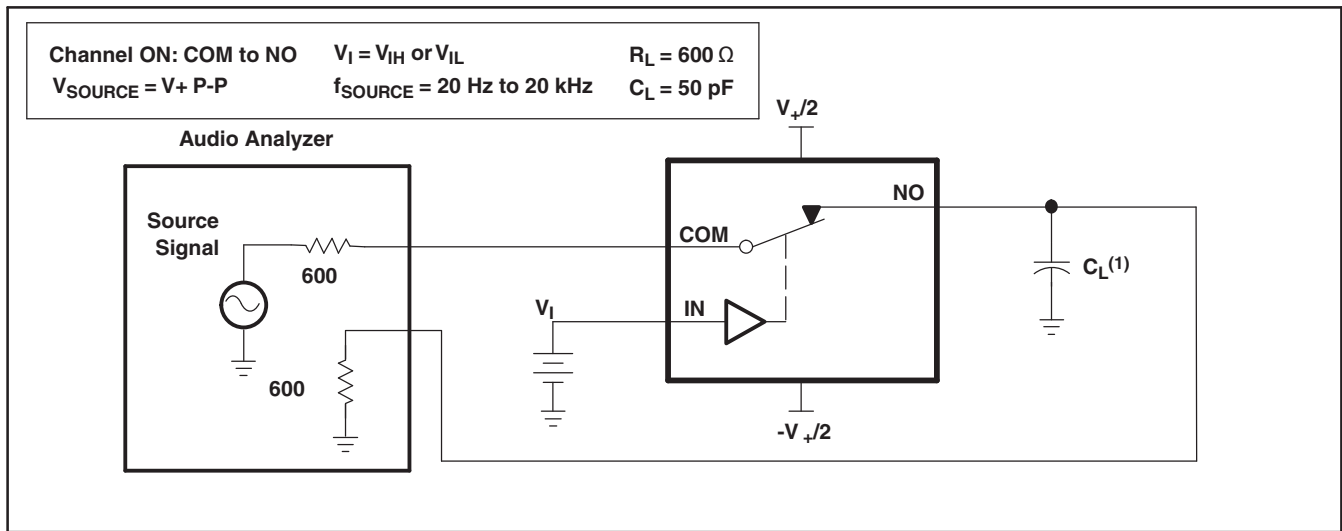

- A. C<sub>L</sub> includes probe and jig capacitance.

Figure 25. Total Harmonic Distortion (THD)

---

## REVISION HISTORY

Changes from Revision A (December 2009) to Revision B	Page
• Added Logic Diagram. ....	<a href="#">2</a>

---

**PACKAGING INFORMATION**

Orderable Device	Status <sup>(1)</sup>	Package Type	Package Drawing	Pins	Package Qty	Eco Plan <sup>(2)</sup>	Lead/ Ball Finish	MSL Peak Temp <sup>(3)</sup>	Samples (Requires Login)
TS5A12301EYFPR	ACTIVE	DSBGA	YFP	6	3000	Green (RoHS & no Sb/Br)	SNAGCU	Level-1-260C-UNLIM	

<sup>(1)</sup> The marketing status values are defined as follows:

**ACTIVE:** Product device recommended for new designs.

**LIFEBUY:** TI has announced that the device will be discontinued, and a lifetime-buy period is in effect.

**NRND:** Not recommended for new designs. Device is in production to support existing customers, but TI does not recommend using this part in a new design.

**PREVIEW:** Device has been announced but is not in production. Samples may or may not be available.

**OBSOLETE:** TI has discontinued the production of the device.

<sup>(2)</sup> Eco Plan - The planned eco-friendly classification: Pb-Free (RoHS), Pb-Free (RoHS Exempt), or Green (RoHS & no Sb/Br) - please check <http://www.ti.com/productcontent> for the latest availability information and additional product content details.

**TBD:** The Pb-Free/Green conversion plan has not been defined.

**Pb-Free (RoHS):** TI's terms "Lead-Free" or "Pb-Free" mean semiconductor products that are compatible with the current RoHS requirements for all 6 substances, including the requirement that lead not exceed 0.1% by weight in homogeneous materials. Where designed to be soldered at high temperatures, TI Pb-Free products are suitable for use in specified lead-free processes.

**Pb-Free (RoHS Exempt):** This component has a RoHS exemption for either 1) lead-based flip-chip solder bumps used between the die and package, or 2) lead-based die adhesive used between the die and leadframe. The component is otherwise considered Pb-Free (RoHS compatible) as defined above.

**Green (RoHS & no Sb/Br):** TI defines "Green" to mean Pb-Free (RoHS compatible), and free of Bromine (Br) and Antimony (Sb) based flame retardants (Br or Sb do not exceed 0.1% by weight in homogeneous material)

<sup>(3)</sup> MSL, Peak Temp. -- The Moisture Sensitivity Level rating according to the JEDEC industry standard classifications, and peak solder temperature.

**Important Information and Disclaimer:** The information provided on this page represents TI's knowledge and belief as of the date that it is provided. TI bases its knowledge and belief on information provided by third parties, and makes no representation or warranty as to the accuracy of such information. Efforts are underway to better integrate information from third parties. TI has taken and continues to take reasonable steps to provide representative and accurate information but may not have conducted destructive testing or chemical analysis on incoming materials and chemicals. TI and TI suppliers consider certain information to be proprietary, and thus CAS numbers and other limited information may not be available for release.

In no event shall TI's liability arising out of such information exceed the total purchase price of the TI part(s) at issue in this document sold by TI to Customer on an annual basis.

## TAPE AND REEL INFORMATION

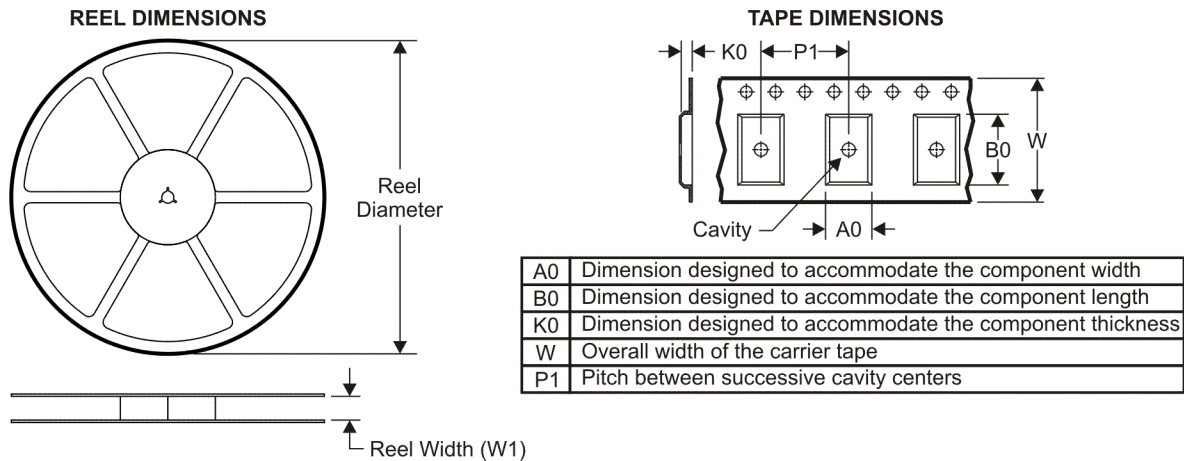

### QUADRANT ASSIGNMENTS FOR PIN 1 ORIENTATION IN TAPE



\*All dimensions are nominal

Device	Package Type	Package Drawing	Pins	SPQ	Reel Diameter (mm)	Reel Width W1 (mm)	A0 (mm)	B0 (mm)	K0 (mm)	P1 (mm)	W (mm)	Pin1 Quadrant
TS5A12301EYFPR	DSBGA	YFP	6	3000	180.0	8.4	0.89	1.29	0.62	4.0	8.0	Q1

**TAPE AND REEL BOX DIMENSIONS**

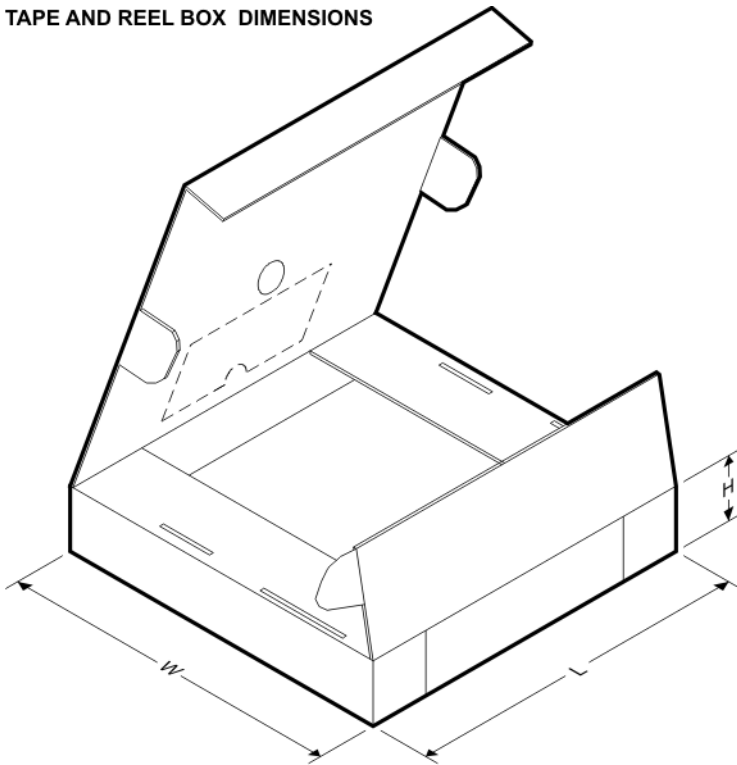

\*All dimensions are nominal

Device	Package Type	Package Drawing	Pins	SPQ	Length (mm)	Width (mm)	Height (mm)
TS5A12301EYFPR	DSBGA	YFP	6	3000	220.0	220.0	34.0

YFP (R-XBGA-N6)

DIE-SIZE BALL GRID ARRAY

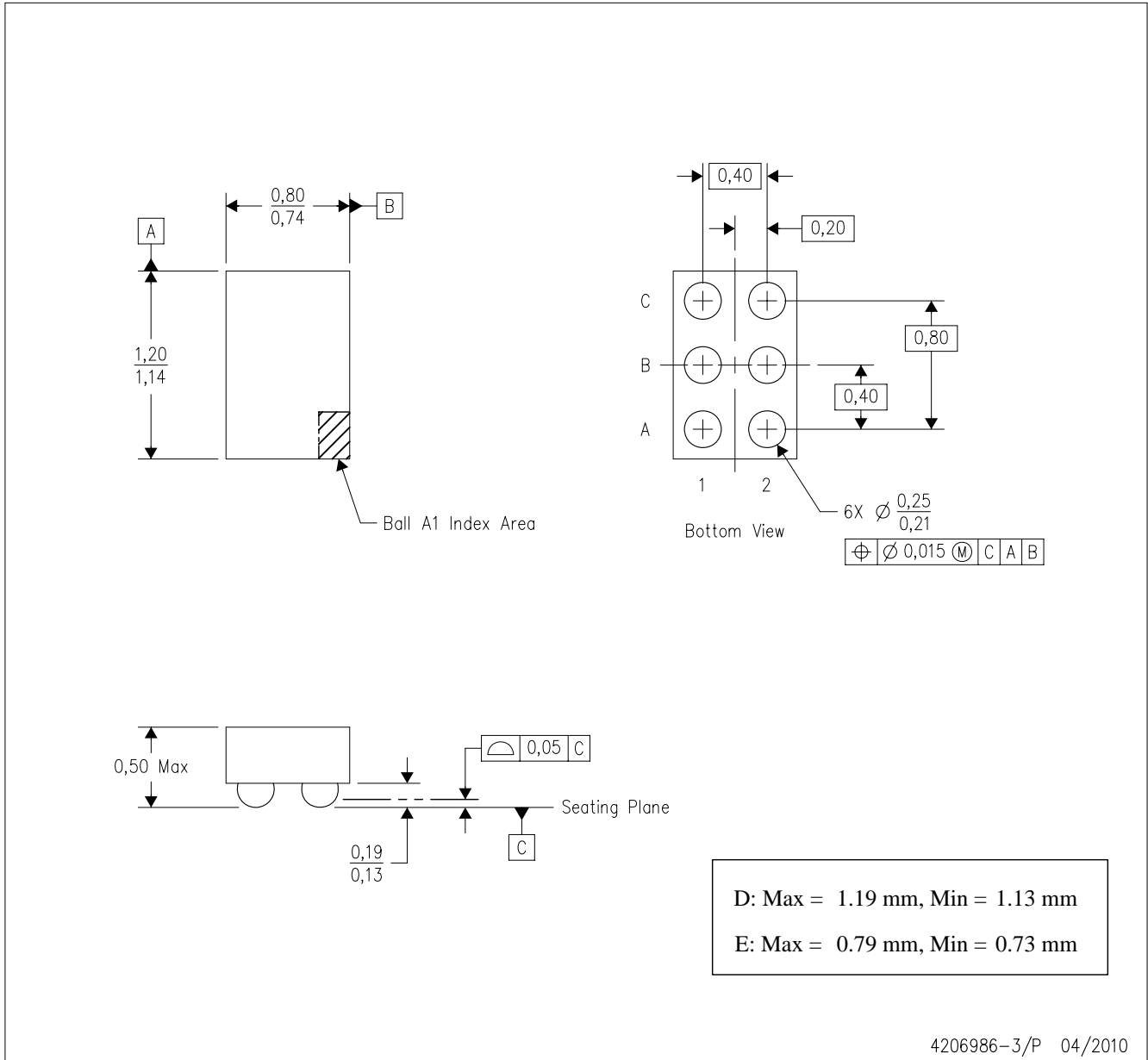

- NOTES:
- A. All linear dimensions are in millimeters. Dimensioning and tolerancing per ASME Y14.5M-1994.
  - B. This drawing is subject to change without notice.
  - C. NanoFree™ package configuration.
  - D. This is a Pb-free solder ball design.

# MECHANICAL DATA

YFP (S-XBGA-N16)

DIE-SIZE BALL GRID ARRAY

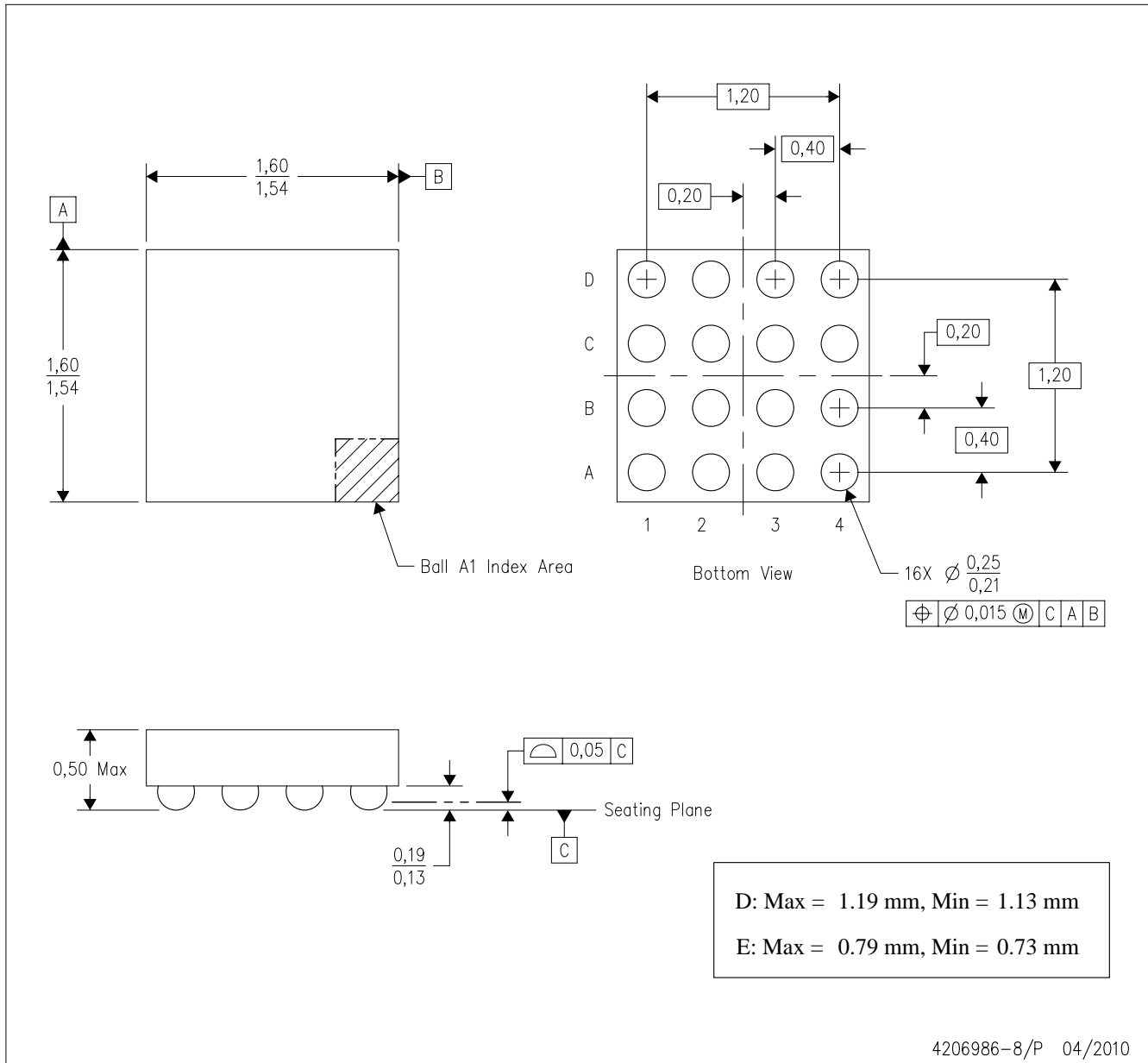

- NOTES:
- All linear dimensions are in millimeters. Dimensioning and tolerancing per ASME Y14.5M-1994.
  - This drawing is subject to change without notice.
  - NanoFree™ package configuration.
  - This is a Pb-free solder ball design.

NanoFree is a trademark of Texas Instruments.

## IMPORTANT NOTICE

Texas Instruments Incorporated and its subsidiaries (TI) reserve the right to make corrections, modifications, enhancements, improvements, and other changes to its products and services at any time and to discontinue any product or service without notice. Customers should obtain the latest relevant information before placing orders and should verify that such information is current and complete. All products are sold subject to TI's terms and conditions of sale supplied at the time of order acknowledgment.

TI warrants performance of its hardware products to the specifications applicable at the time of sale in accordance with TI's standard warranty. Testing and other quality control techniques are used to the extent TI deems necessary to support this warranty. Except where mandated by government requirements, testing of all parameters of each product is not necessarily performed.

TI assumes no liability for applications assistance or customer product design. Customers are responsible for their products and applications using TI components. To minimize the risks associated with customer products and applications, customers should provide adequate design and operating safeguards.

TI does not warrant or represent that any license, either express or implied, is granted under any TI patent right, copyright, mask work right, or other TI intellectual property right relating to any combination, machine, or process in which TI products or services are used. Information published by TI regarding third-party products or services does not constitute a license from TI to use such products or services or a warranty or endorsement thereof. Use of such information may require a license from a third party under the patents or other intellectual property of the third party, or a license from TI under the patents or other intellectual property of TI.

Reproduction of TI information in TI data books or data sheets is permissible only if reproduction is without alteration and is accompanied by all associated warranties, conditions, limitations, and notices. Reproduction of this information with alteration is an unfair and deceptive business practice. TI is not responsible or liable for such altered documentation. Information of third parties may be subject to additional restrictions.

Resale of TI products or services with statements different from or beyond the parameters stated by TI for that product or service voids all express and any implied warranties for the associated TI product or service and is an unfair and deceptive business practice. TI is not responsible or liable for any such statements.

TI products are not authorized for use in safety-critical applications (such as life support) where a failure of the TI product would reasonably be expected to cause severe personal injury or death, unless officers of the parties have executed an agreement specifically governing such use. Buyers represent that they have all necessary expertise in the safety and regulatory ramifications of their applications, and acknowledge and agree that they are solely responsible for all legal, regulatory and safety-related requirements concerning their products and any use of TI products in such safety-critical applications, notwithstanding any applications-related information or support that may be provided by TI. Further, Buyers must fully indemnify TI and its representatives against any damages arising out of the use of TI products in such safety-critical applications.

TI products are neither designed nor intended for use in military/aerospace applications or environments unless the TI products are specifically designated by TI as military-grade or "enhanced plastic." Only products designated by TI as military-grade meet military specifications. Buyers acknowledge and agree that any such use of TI products which TI has not designated as military-grade is solely at the Buyer's risk, and that they are solely responsible for compliance with all legal and regulatory requirements in connection with such use.

TI products are neither designed nor intended for use in automotive applications or environments unless the specific TI products are designated by TI as compliant with ISO/TS 16949 requirements. Buyers acknowledge and agree that, if they use any non-designated products in automotive applications, TI will not be responsible for any failure to meet such requirements.

Following are URLs where you can obtain information on other Texas Instruments products and application solutions:

### Products

Audio	<a href="http://www.ti.com/audio">www.ti.com/audio</a>
Amplifiers	<a href="http://amplifier.ti.com">amplifier.ti.com</a>
Data Converters	<a href="http://dataconverter.ti.com">dataconverter.ti.com</a>
DLP® Products	<a href="http://www.dlp.com">www.dlp.com</a>
DSP	<a href="http://dsp.ti.com">dsp.ti.com</a>
Clocks and Timers	<a href="http://www.ti.com/clocks">www.ti.com/clocks</a>
Interface	<a href="http://interface.ti.com">interface.ti.com</a>
Logic	<a href="http://logic.ti.com">logic.ti.com</a>
Power Mgmt	<a href="http://power.ti.com">power.ti.com</a>
Microcontrollers	<a href="http://microcontroller.ti.com">microcontroller.ti.com</a>
RFID	<a href="http://www.ti-rfid.com">www.ti-rfid.com</a>
RF/IF and ZigBee® Solutions	<a href="http://www.ti.com/lprf">www.ti.com/lprf</a>

### Applications

Communications and Telecom	<a href="http://www.ti.com/communications">www.ti.com/communications</a>
Computers and Peripherals	<a href="http://www.ti.com/computers">www.ti.com/computers</a>
Consumer Electronics	<a href="http://www.ti.com/consumer-apps">www.ti.com/consumer-apps</a>
Energy and Lighting	<a href="http://www.ti.com/energy">www.ti.com/energy</a>
Industrial	<a href="http://www.ti.com/industrial">www.ti.com/industrial</a>
Medical	<a href="http://www.ti.com/medical">www.ti.com/medical</a>
Security	<a href="http://www.ti.com/security">www.ti.com/security</a>
Space, Avionics and Defense	<a href="http://www.ti.com/space-avionics-defense">www.ti.com/space-avionics-defense</a>
Transportation and Automotive	<a href="http://www.ti.com/automotive">www.ti.com/automotive</a>
Video and Imaging	<a href="http://www.ti.com/video">www.ti.com/video</a>
Wireless	<a href="http://www.ti.com/wireless-apps">www.ti.com/wireless-apps</a>

TI E2E Community Home Page

[e2e.ti.com](http://e2e.ti.com)

Mailing Address: Texas Instruments, Post Office Box 655303, Dallas, Texas 75265  
Copyright © 2011, Texas Instruments Incorporated