

TPS735 500-mA, Low Quiescent Current, Ultra-Low Noise, High PSRR, Low-Dropout Linear Regulator

1 Features

- Input Voltage: 2.7 V to 6.5 V
- 500-mA Low-Dropout Regulator With EN
- Low I_Q : 46 μ A
- Multiple Output Voltage Versions Available:
 - Fixed Outputs of 1.2 V to 4.3 V
 - Adjustable Outputs from 1.25 V to 6 V
- High PSRR: 68 dB at 1 kHz
- Ultra-low Noise: 13.2 μ V_{RMS}
- Fast Start-Up Time: 45 μ s
- Stable with a Standard, 2.2- μ F, Low-ESR Output Capacitor
- Excellent Load and Line Transient Response
- 2% Overall Accuracy (Load, Line, and Temperature, $V_{OUT} > 2.2$ V)
- Very Low Dropout: 280 mV at 500 mA
- 2-mm x 2-mm SON-6 and 3-mm x 3-mm SON-8 Packages

2 Applications

- Printers
- WiFi®, WiMax Modules
- Cellular Phones, Smart Phones
- Microprocessor Power

4 Typical Application

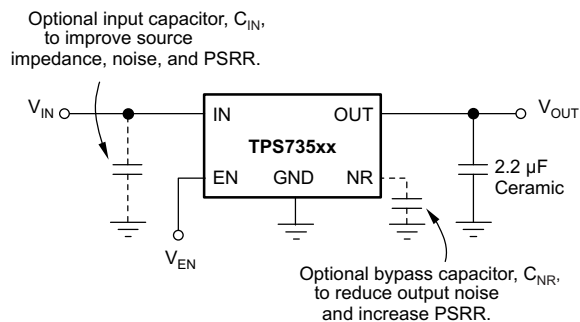

3 Description

The TPS735 family of low-dropout (LDO), low-power linear regulators offers excellent ac performance with very low ground current. High power-supply rejection ratio (PSRR), low noise, fast start-up, and excellent line and load transient responses are provided while consuming a very low 46- μ A (typical) ground current.

The TPS735 family of devices is stable with ceramic capacitors and uses an advanced BiCMOS fabrication process to yield a typical dropout voltage of 280 mV at 500-mA output. The TPS735 family of devices uses a precision voltage reference and feedback loop to achieve overall accuracy of 2% ($V_{OUT} > 2.2$ V) over all load, line, process, and temperature variations. This family of devices is fully specified from $T_A = -40^\circ\text{C}$ to 125°C and is offered in a low-profile, 3-mm x 3-mm SON-8 package and a 2-mm x 2-mm SON-6 package.

Device Information⁽¹⁾

PART NUMBER	PACKAGE	BODY SIZE (NOM)
TPS735	VSON (6)	2.00 mm x 2.00 mm
	VSON (8)	3.00 mm x 3.00 mm

(1) For all available packages, see the orderable addendum at the end of the data sheet.



Table of Contents

<p>1 Features 1</p> <p>2 Applications 1</p> <p>3 Description 1</p> <p>4 Typical Application 1</p> <p>5 Revision History..... 2</p> <p>6 Pin Configuration and Functions 4</p> <p>7 Specifications..... 5</p> <p style="padding-left: 20px;">7.1 Absolute Maximum Ratings 5</p> <p style="padding-left: 20px;">7.2 ESD Ratings..... 5</p> <p style="padding-left: 20px;">7.3 Recommended Operating Conditions..... 5</p> <p style="padding-left: 20px;">7.4 Thermal Information 6</p> <p style="padding-left: 20px;">7.5 Electrical Characteristics..... 7</p> <p style="padding-left: 20px;">7.6 Typical Characteristics 8</p> <p>8 Detailed Description 10</p> <p style="padding-left: 20px;">8.1 Overview 10</p> <p style="padding-left: 20px;">8.2 Functional Block Diagrams 10</p> <p style="padding-left: 20px;">8.3 Feature Description..... 11</p> <p style="padding-left: 20px;">8.4 Device Functional Modes..... 12</p>	<p>9 Application and Implementation 13</p> <p style="padding-left: 20px;">9.1 Application Information..... 13</p> <p style="padding-left: 20px;">9.2 Typical Applications 13</p> <p>10 Power-Supply Recommendations 16</p> <p>11 Layout..... 16</p> <p style="padding-left: 20px;">11.1 Layout Guidelines 16</p> <p style="padding-left: 20px;">11.2 Layout Example 16</p> <p style="padding-left: 20px;">11.3 Power Dissipation 17</p> <p style="padding-left: 20px;">11.4 Estimating Junction Temperature 18</p> <p style="padding-left: 20px;">11.5 Package Mounting 19</p> <p>12 Device and Documentation Support 20</p> <p style="padding-left: 20px;">12.1 Device Support..... 20</p> <p style="padding-left: 20px;">12.2 Documentation Support 20</p> <p style="padding-left: 20px;">12.3 Trademarks 20</p> <p style="padding-left: 20px;">12.4 Electrostatic Discharge Caution..... 20</p> <p style="padding-left: 20px;">12.5 Glossary 20</p> <p>13 Mechanical, Packaging, and Orderable Information 20</p>
--	---

5 Revision History

NOTE: Page numbers for previous revisions may differ from page numbers in the current version.

Changes from Revision K (August, 2013) to Revision L

Page

<ul style="list-style-type: none"> • Added <i>ESD Ratings</i> table, <i>Feature Description</i> section, <i>Device Functional Modes</i>, <i>Application and Implementation</i> section, <i>Power Supply Recommendations</i> section, <i>Layout</i> section, <i>Device and Documentation Support</i> section, and <i>Mechanical, Packaging, and Orderable Information</i> sections 1 • Added first bullet item in <i>Features</i> list 1 • Changed fourth bullet item in <i>Features</i> list to "fixed outputs of 1.2 V" 1 • Changed eighth bullet item in <i>Features</i> list 1 • Changed last bullet in <i>Features</i> list 1 • Changed last <i>Applications</i> list item 1 • Changed <i>Pin Configuration and Functions</i> section; updated table format and pin descriptions to meet new standards 4 • Changed C_{NR} value notation from 0.01 μF to 10 nF throughout <i>Electrical Characteristics</i>..... 7 • Changed feedback voltage parameter values and measured test conditions 7 • Changed output current limit maximum specified value 7 • Changed power-supply rejection ratio typical specified values for 100 Hz, 10 kHz, and 100 kHz frequency test conditions 7 • Added note (1) to Figure 1 8 • Changed y-axis title for Figure 6 8 • Changed y-axis title for Figure 7 8 • Changed footnote for Figure 13..... 10 • Changed reference to noise-reduction capacitor (C_{NR}) to feed-forward capacitor (C_{FF}) in Transient Response..... 11 • Changed noise-reduction capacitor to feed-forward capacitor in Figure 16 13 • Changed references to "noise-reduction capacitor" (C_{NR}) to "feed-forward capacitor" (C_{FF}) and section title from "Feedback Capacitor Requirements" to "Feed-forward Capacitor Requirements" in Feed-Forward Capacitor Requirements (TPS73501 Only) section 14 • Changed C_{NR} value notation from 0.01 μF to 10 nF in Output Noise section..... 14 	<p>1</p> <p>1</p> <p>1</p> <p>1</p> <p>1</p> <p>1</p> <p>4</p> <p>7</p> <p>7</p> <p>7</p> <p>7</p> <p>8</p> <p>8</p> <p>8</p> <p>10</p> <p>11</p> <p>13</p> <p>14</p> <p>14</p>
--	---

Changes from Revision J (May, 2011) to Revision K **Page**

- Added last sentence to first paragraph of *Startup and Noise Reduction Capacitor* section 11
-

Changes from Revision I (April, 2011) to Revision J **Page**

- Replaced the *Dissipation Ratings* with *Thermal Information*..... 6
 - Revised conditions for *Typical Characteristics* to include statement about TPS73525 device availability 8
 - Added *Estimating Junction Temperature* section 18
 - Updated *Power Dissipation* section 19
-

Changes from Revision H (November, 2009) to Revision I **Page**

- Corrected typo in *Electrical Characteristics* table for V_{OUT} specification, DRV package test conditions, $V_{OUT} \leq 2.2V$ 7
-

Changes from Revision G (March 2009) to Revision H **Page**

- Revised bullet point in *Features* list to show very low dropout of 280mV 1
 - Changed dropout voltage typical specification from 250mV to 280mV 7
-

6 Pin Configuration and Functions

DRB PACKAGE
3-mm × 3-mm VSON-8
(TOP VIEW)

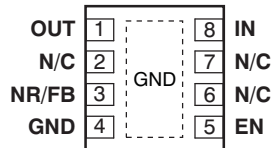

DRV PACKAGE
2-mm × 2-mm VSON-6
(TOP VIEW)

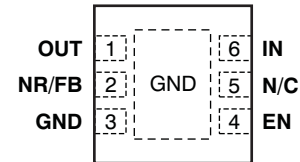

N/C - No internal connection

Pin Functions

NAME	PIN		I/O	DESCRIPTION
	NO			
	DRV	DRB		
IN	6	8	I	Input supply. A 0.1- μ F to 1- μ F, low ESR capacitor should be placed from this pin to ground, near the device.
GND	3, Pad	4	—	Ground. The pad must be tied to GND.
EN	4	5	I	Driving the enable pin (EN) high turns on the regulator. Driving this pin low puts the regulator into shutdown mode. The EN pin can be connected to the IN pin if not used.
NR	2	3	—	This pin is only available for the fixed voltage versions. Connecting an external capacitor to this pin bypasses noise generated by the internal band gap and allows the output noise to be reduced to very low levels. The maximum recommended capacitor is 0.01 μ F.
FB	2	3	I	This pin is only available for the adjustable version. The FB pin is the input to the control-loop error amplifier, and is used to set the output voltage of the device. This pin must not be left floating.
OUT	1	1	O	This pin is the output of the regulator. A small, 2.2- μ F ceramic capacitor is required from this pin to ground to assure stability. The minimum output capacitance needed for stability is 2 μ F.
N/C	5	2, 6, 7	—	Not internally connected.

7 Specifications

7.1 Absolute Maximum Ratings

At $-40^{\circ}\text{C} \leq T_J$ and $T_A \leq 125^{\circ}\text{C}$ (unless otherwise noted). All voltages are with respect to GND.⁽¹⁾

		MIN	MAX	UNIT
Voltage	V_{IN}	-0.3	+7	V
	V_{EN}	-0.3	$V_{IN} + 0.3$	V
	V_{FB}	-0.3	+1.6	V
	V_{OUT}	-0.3	$V_{IN} + 0.3$	V
Current	I_{OUT}	Internally limited		A
Continuous total power dissipation	$P_{D(\text{tot})}$	See Thermal Information		
Temperature	Operating junction, T_J	-40	150	$^{\circ}\text{C}$
	Storage, T_{stg}	-55	150	$^{\circ}\text{C}$

- (1) Stresses beyond those listed as *absolute maximum ratings* may cause permanent damage to the device. These are stress ratings only, and functional operation of the device at these or any other conditions beyond those indicated as *recommended operating conditions* is not implied. Exposure to absolute-maximum-rated conditions for extended periods may affect device reliability.

7.2 ESD Ratings

		VALUE	UNIT
V_{ESD} Electrostatic discharge	Human body model (HBM), per ANSI/ESDA/JEDEC JS-001, all pins ⁽¹⁾	± 2000	V
	Charged device model (CDM), per JEDEC specification JESD22-C101, all pins ⁽²⁾	± 500	V

- (1) JEDEC document JEP155 states that 500-V HBM allows safe manufacturing with a standard ESD control process.
(2) JEDEC document JEP157 states that 250-V CDM allows safe manufacturing with a standard ESD control process.

7.3 Recommended Operating Conditions

over operating junction temperature range (unless otherwise noted)

		MIN	NOM	MAX	UNIT
V_{IN}	Input voltage	2.7		6.5	V
V_{OUT}	Output voltage	V_{FB}		6	V
I_{OUT}	Output current ⁽¹⁾	0		500	mA
T_A	Operating free-air temperature	-40		125	$^{\circ}\text{C}$
C_{IN}	Input capacitor		1		μF
C_{OUT}	Output capacitor		2		μF
C_{NR}	Noise reduction capacitor		10		nF
C_{FF} ⁽²⁾	Feed-forward capacitor	3	22	1000	pF
R_2 ⁽²⁾			110		k Ω

- (1) When operating at T_J near 125°C , $I_{OUT(\text{min})}$ is 500 μA .
(2) Adjustable version only (TPS73501).

7.4 Thermal Information

THERMAL METRIC ⁽¹⁾		TPS735 ⁽²⁾		UNIT
		DRB VSON	DRV ⁽³⁾ VSON	
		8 PINS	6 PINS	
R _{θJA}	Junction-to-ambient thermal resistance ⁽⁴⁾	52.2	65.1	°C/W
R _{θJC(top)}	Junction-to-case (top) thermal resistance ⁽⁵⁾	59.4	85.6	
R _{θJB}	Junction-to-board thermal resistance ⁽⁶⁾	19.3	34.7	
Ψ _{JT}	Junction-to-top characterization parameter ⁽⁷⁾	2	1.6	
Ψ _{JB}	Junction-to-board characterization parameter ⁽⁸⁾	19.3	35.1	
R _{θJC(bot)}	Junction-to-case (bottom) thermal resistance ⁽⁹⁾	11.8	5.8	

- (1) For more information about traditional and new thermal metrics, see the *IC Package Thermal Metrics* application report, [SPRA953A](#).
- (2) Thermal data for the DRB, DCQ, and DRV packages are derived by thermal simulations based on JEDEC-standard methodology as specified in the JESD51 series. The following assumptions are used in the simulations:
 - (a) i. DRB: The exposed pad is connected to the PCB ground layer through a 2x2 thermal via array.
 - ii. DRV: The exposed pad is connected to the PCB ground layer through a 2x2 thermal via array. Due to size limitation of thermal pad, 0.8-mm pitch array is used which is off the JEDEC standard.
 - (b) i. DRB: The top and bottom copper layers are assumed to have a 20% thermal conductivity of copper representing a 20% copper coverage.
 - ii. DRV: The top and bottom copper layers are assumed to have a 20% thermal conductivity of copper representing a 20% copper coverage.
 - (c) These data were generated with only a single device at the center of a JEDEC high-K (2s2p) board with 3-in x 3-in copper area. To understand the effects of the copper area on thermal performance, see the [Power Dissipation](#) and [Estimating Junction Temperature](#) sections.
- (3) Power dissipation may limit operating range.
- (4) The junction-to-ambient thermal resistance under natural convection is obtained in a simulation on a JEDEC-standard, high-K board, as specified in JESD51-7, in an environment described in JESD51-2a.
- (5) The junction-to-case (top) thermal resistance is obtained by simulating a cold plate test on the top of the package. No specific JEDEC-standard test exists, but a close description can be found in the ANSI SEMI standard G30-88.
- (6) The junction-to-board thermal resistance is obtained by simulating in an environment with a ring cold plate fixture to control the PCB temperature, as described in JESD51-8.
- (7) The junction-to-top characterization parameter, Ψ_{JT}, estimates the junction temperature of a device in a real system and is extracted from the simulation data to obtain θ_{JA} using a procedure described in JESD51-2a (sections 6 and 7).
- (8) The junction-to-board characterization parameter, Ψ_{JB}, estimates the junction temperature of a device in a real system and is extracted from the simulation data to obtain θ_{JA} using a procedure described in JESD51-2a (sections 6 and 7).
- (9) The junction-to-case (bottom) thermal resistance is obtained by simulating a cold plate test on the exposed (power) pad. No specific JEDEC standard test exists, but a close description can be found in the ANSI SEMI standard G30-88.

7.5 Electrical Characteristics

Over operating temperature range ($-40^{\circ}\text{C} \leq T_J \leq 125^{\circ}\text{C}$), $V_{IN} = V_{OUT(nom)} + 0.5\text{ V}$ or 2.7 V (whichever is greater), $I_{OUT} = 1\text{ mA}$, $V_{EN} = V_{IN}$, $C_{OUT} = 2.2\text{ }\mu\text{F}$, and $C_{NR} = 10\text{ nF}$, unless otherwise noted. For the adjustable version (TPS73501), $V_{OUT} = 3\text{ V}$. Typical values are at $T_A = 25^{\circ}\text{C}$.

PARAMETER	TEST CONDITIONS	MIN	TYP	MAX	UNIT		
V_{IN}	Input voltage ⁽¹⁾	2.7		6.5	V		
V_{FB}	Internal reference (adjustable version only)	1.196	1.208	1.220	V		
V_{OUT}	Output voltage range (adjustable version only)	V_{FB}		6	V		
DC output accuracy ⁽¹⁾	$1\text{ mA} \leq I_{OUT} \leq 500\text{ mA}$, $V_{OUT} + 0.5\text{ V} \leq V_{IN} < 6.5\text{ V}$	$V_{OUT} > 2.2\text{ V}$	-2%	$\pm 1\%$	2%		
		$V_{OUT} \leq 2.2\text{ V}$	-3%	$\pm 1\%$	3%		
$\Delta V_{OUT(\Delta V_{IN})}$	Line regulation ⁽¹⁾	$V_{OUT(nom)} + 0.5\text{ V} \leq V_{IN} \leq 6.5\text{ V}$		0.02	%/V		
$\Delta V_{OUT(\Delta I_{OUT})}$	Load regulation	$500\text{ }\mu\text{A} \leq I_{OUT} \leq 500\text{ mA}$		0.005	%/mA		
V_{DO}	Dropout voltage ⁽²⁾ ($V_{IN} = V_{OUT(nom)} - 0.1\text{ V}$)	$I_{OUT} = 500\text{ mA}$		280	500	mV	
I_{LIM}	Output current limit	$V_{OUT} = 0.9 \times V_{OUT(nom)}$, $V_{IN} = V_{OUT(nom)} + 0.9\text{ V}$, $V_{IN} \geq 2.7\text{ V}$		800	1170	1900	mA
I_{GND}	Ground pin current	$10\text{ mA} \leq I_{OUT} \leq 500\text{ mA}$		45	65	μA	
I_{SHDN}	Shutdown current	$V_{EN} \leq 0\text{ V}$		0.15	1	μA	
I_{FB}	Feedback pin current (adjustable version only)	$V_{OUT(nom)} = 1.2\text{ V}$		-0.5	0.5	μA	
PSRR	Power-supply rejection ratio	$V_{IN} = 3.85\text{ V}$, $V_{OUT} = 2.85\text{ V}$, $C_{NR} = 0.01\text{ }\mu\text{F}$, $I_{OUT} = 100\text{ mA}$	$f = 100\text{ Hz}$	66	dB		
			$f = 1\text{ kHz}$	68			
			$f = 10\text{ kHz}$	44			
			$f = 100\text{ kHz}$	22			
V_n	Output noise voltage	BW = 10 Hz to 100 kHz, $V_{OUT} = 2.8\text{ V}$	$C_{NR} = 10\text{ nF}$	$11 \times V_{OUT}$	μV_{RMS}		
			$C_{NR} = \text{none}$	$95 \times V_{OUT}$			
t_{STR}	Start-up time	$C_{NR} = \text{none}$	$C_{NR} = \text{none}$	45	μs		
			$C_{NR} = 1\text{ nF}$	45			
			$C_{NR} = 10\text{ nF}$	50			
			$C_{NR} = 47\text{ nF}$	50			
$V_{EN(HI)}$	Enable high (enabled)	1.2			V		
$V_{EN(LO)}$	Enable low (shutdown)			0.4	V		
$I_{EN(HI)}$	Enable pin current, enabled	$V_{EN} = V_{IN} = 6.5\text{ V}$		0.03	1	μA	
T_{sd}	Thermal shutdown temperature	Shutdown, temperature increasing		165	$^{\circ}\text{C}$		
		Reset, temperature decreasing		145			
UVLO	Undervoltage lockout	V_{IN} rising		1.9	2.2	2.65	V
V_{hys}	Hysteresis	V_{IN} falling		70		mV	

(1) Minimum $V_{IN} = V_{OUT} + V_{DO}$ or 2.7 V , whichever is greater.

(2) V_{DO} is not measured for this family of devices with $V_{OUT(nom)} < 2.8\text{ V}$ because the minimum $V_{IN} = 2.7\text{ V}$.

7.6 Typical Characteristics

Over operating temperature range ($T_J = -40^{\circ}\text{C}$ to 125°C), $V_{IN} = V_{OUT(nom)} + 0.5\text{ V}$ or 2.7 V , whichever is greater; $I_{OUT} = 1\text{ mA}$, $V_{EN} = V_{IN}$, $C_{OUT} = 2.2\text{ }\mu\text{F}$, $C_{NR} = 10\text{ nF}$, unless otherwise noted. Typical values are at $T_J = 25^{\circ}\text{C}$.

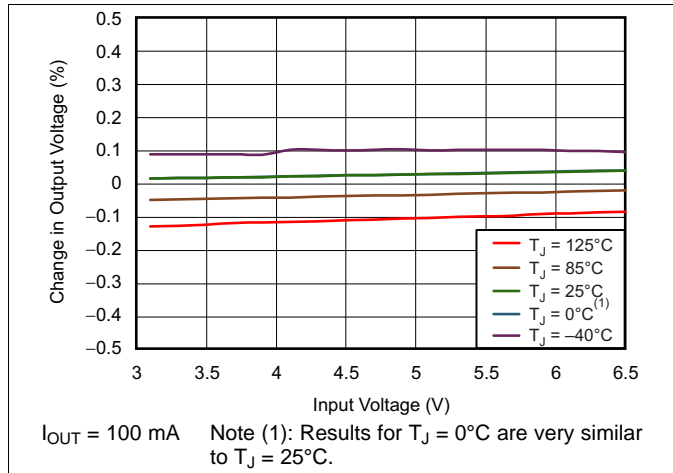

Figure 1. TPS73501 Line Regulation

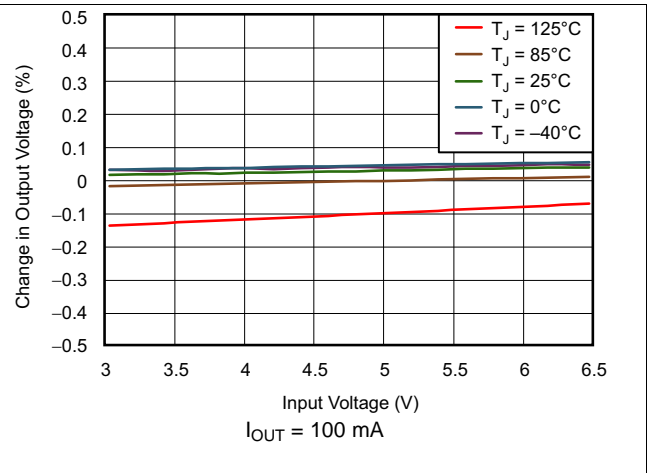

Figure 2. TPS73525 Line Regulation

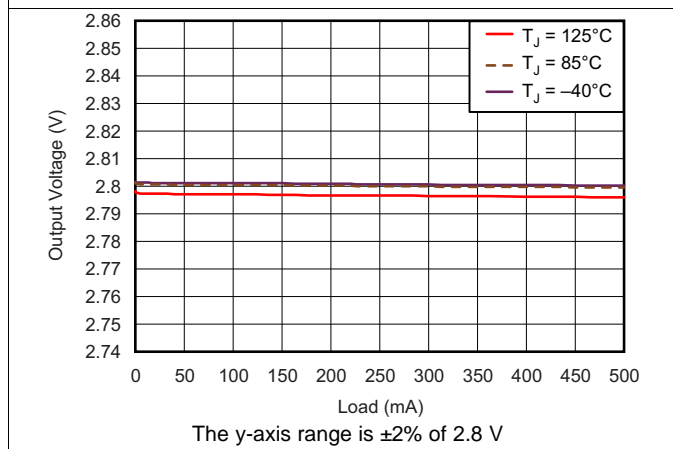

Figure 3. TPS73501 Load Regulation

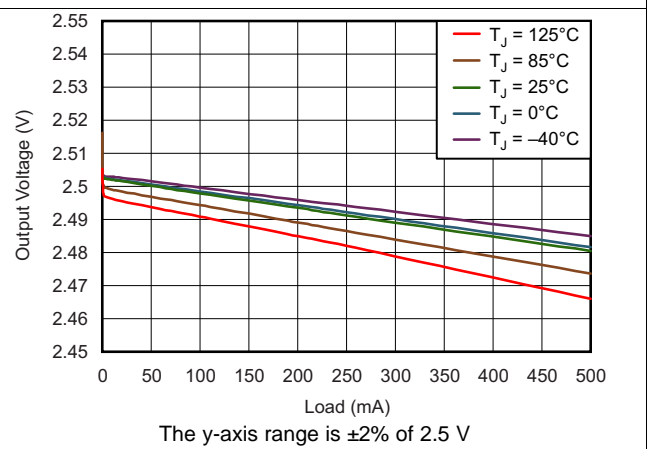

Figure 4. TPS73525 Load Regulation

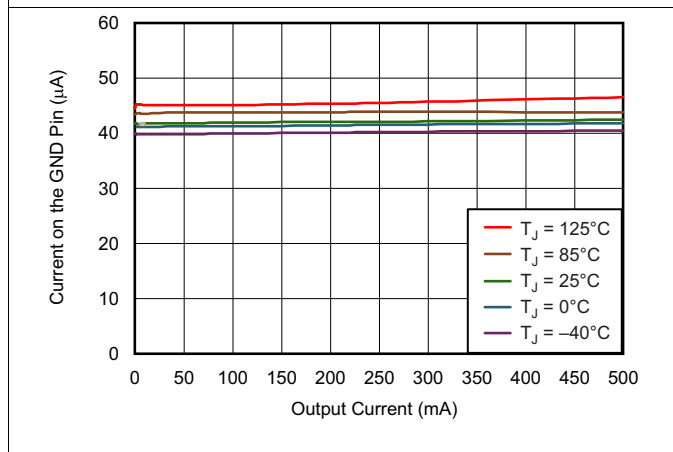

Figure 5. TPS73525 Ground Pin Current vs Output Current

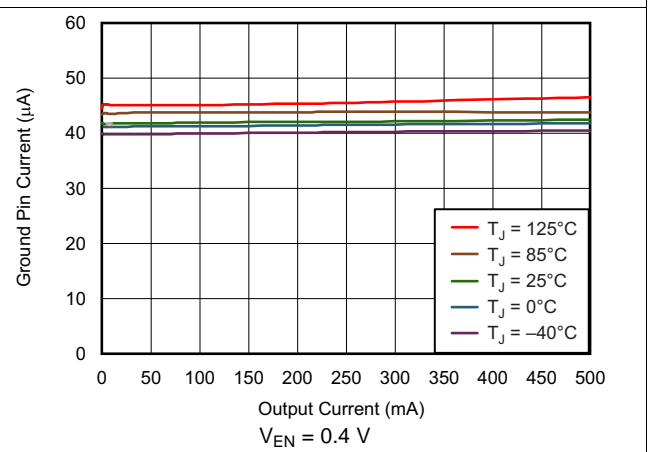

Figure 6. TPS73525 Ground Pin Current (Disable) vs Temperature

Typical Characteristics (continued)

Over operating temperature range ($T_J = -40^{\circ}\text{C}$ to 125°C), $V_{IN} = V_{OUT(nom)} + 0.5\text{ V}$ or 2.7 V , whichever is greater; $I_{OUT} = 1\text{ mA}$, $V_{EN} = V_{IN}$, $C_{OUT} = 2.2\text{ }\mu\text{F}$, $C_{NR} = 10\text{ nF}$, unless otherwise noted. Typical values are at $T_J = 25^{\circ}\text{C}$.

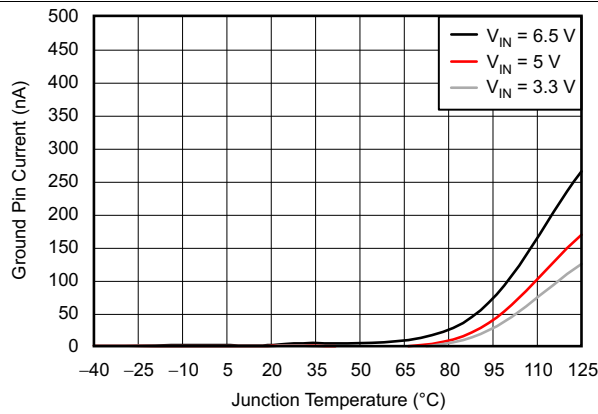

Figure 7. TPS73501 Dropout Voltage vs Output Current

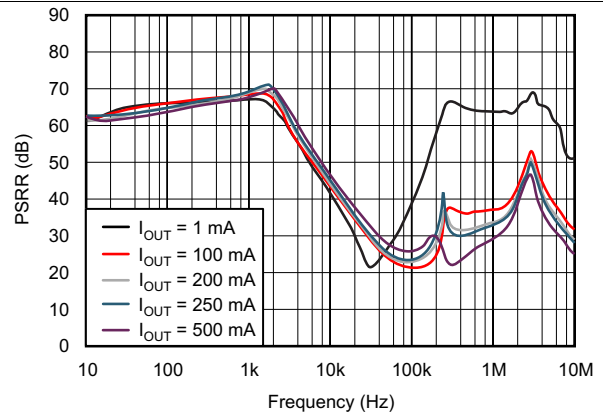

Figure 8. Power-Supply Ripple Rejection vs Frequency ($V_{IN} - V_{OUT} = 1\text{ V}$)

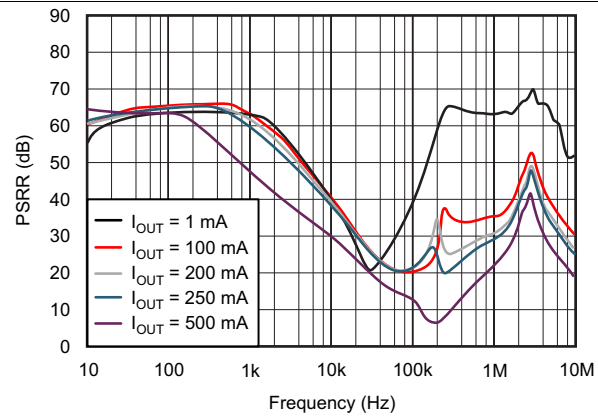

Figure 9. Power-Supply Ripple Rejection vs Frequency ($V_{IN} - V_{OUT} = 0.5\text{ V}$)

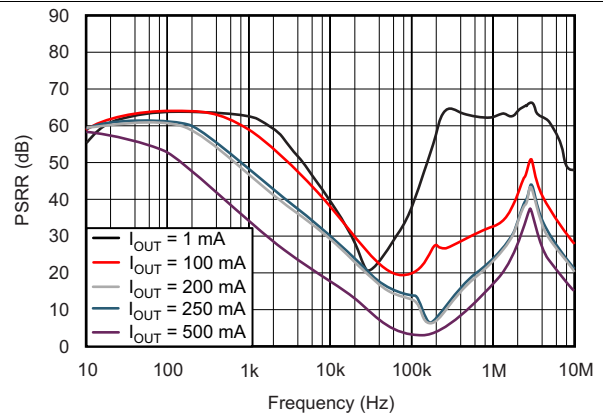

Figure 10. Power-Supply Ripple Rejection vs Frequency ($V_{IN} - V_{OUT} = 0.3\text{ V}$)

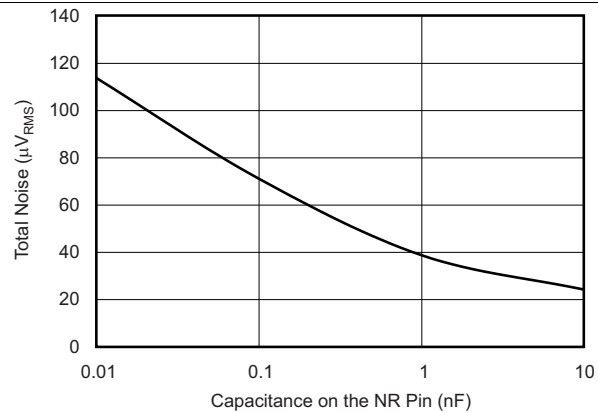

Figure 11. TPS73525 RMS Noise vs C_{NR}

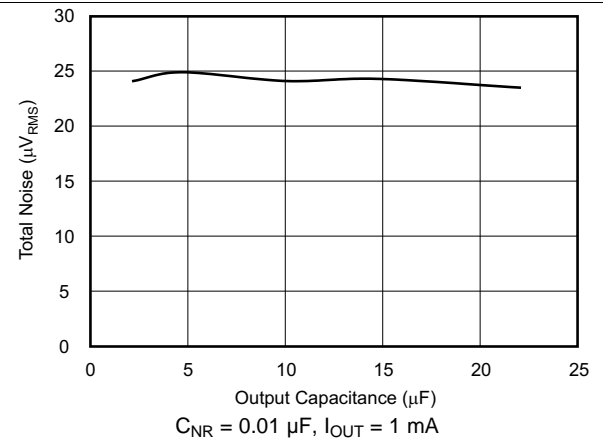

Figure 12. TPS73525 RMS Noise vs C_{OUT}

8 Detailed Description

8.1 Overview

The TPS735 family of low dropout (LDO) regulators combines the high performance required by many radio frequency (RF) and precision analog applications with ultra-low current consumption. High PSRR is provided by a high-gain, high-bandwidth error loop with good supply rejection and very low headroom ($V_{IN} - V_{OUT}$). Fixed voltage versions provide a noise reduction pin to bypass noise generated by the band-gap reference and to improve PSRR. A quick-start circuit fast-charges this capacitor at start-up. The combination of high performance and low ground current also make the TPS735 family of devices an excellent choice for portable applications. All versions have thermal and overcurrent protection and are fully specified from $-40^{\circ}\text{C} \leq T_J \leq 125^{\circ}\text{C}$.

8.2 Functional Block Diagrams

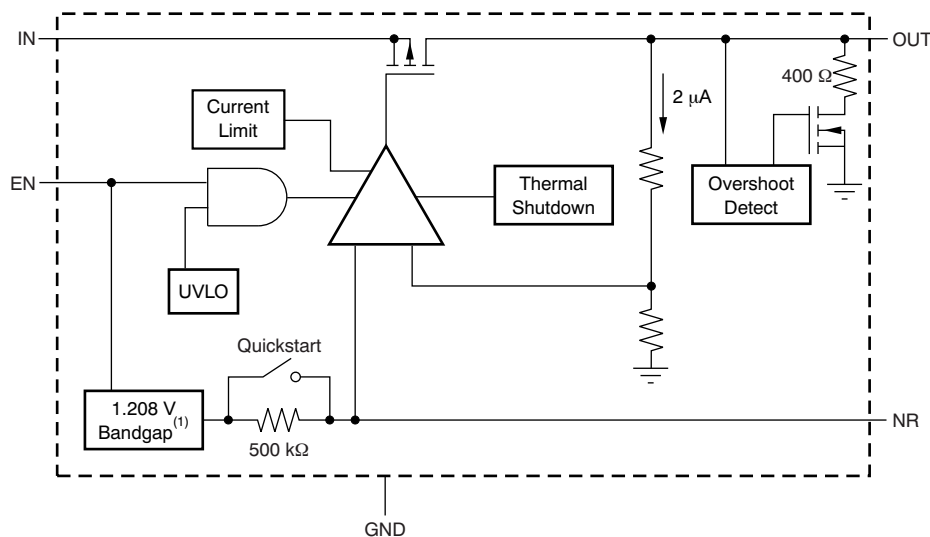

(1) The 1.2-V fixed voltage version has a 1.0-V bandgap instead of a 1.208-V circuit.

Figure 13. Fixed Voltage Versions

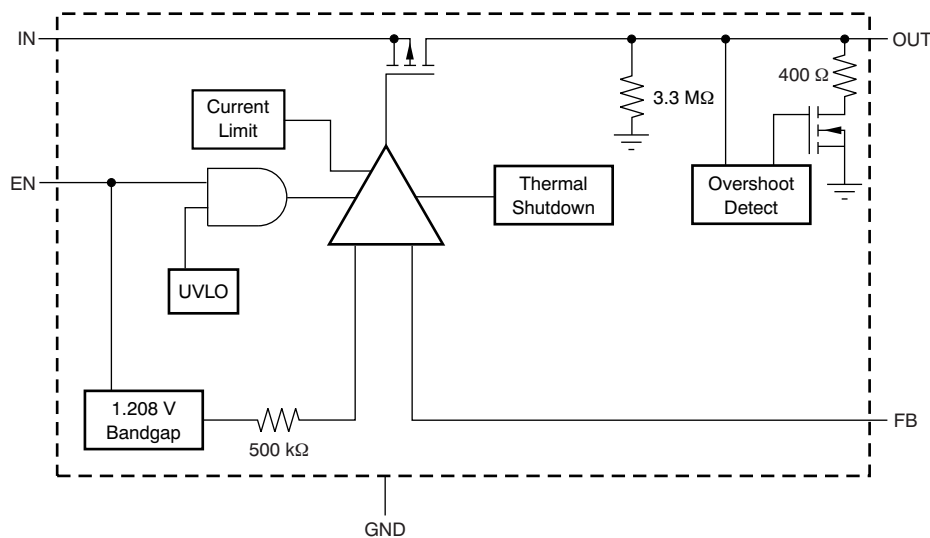

Figure 14. Adjustable Voltage Versions

8.3 Feature Description

8.3.1 Internal Current Limit

The TPS735 internal current-limit helps protect the regulator during fault conditions. During current-limit, the output sources a fixed amount of current that is largely independent of the output voltage. For reliable operation, do not operate the device in current-limit for extended periods of time.

The PMOS pass element in the TPS735 family of devices has a built-in body diode that conducts current when the voltage at the OUT pin exceeds the voltage at the IN pin. This current is not limited, so if extended reverse voltage operation is anticipated, external limiting is appropriate.

8.3.2 Shutdown

The enable pin (EN) is active high and is compatible with standard and low-voltage TTL-CMOS levels. When shutdown capability is not required, the EN pin can be connected to the IN pin.

8.3.3 Dropout Voltage

The TPS735 family of devices uses a PMOS pass transistor to achieve low dropout. When $(V_{IN} - V_{OUT})$ is less than the dropout voltage (V_{DO}), the PMOS pass device is in the linear region of operation and the input-to-output resistance ($R_{(IN/OUT)}$) of the PMOS pass element. V_{DO} scales with the output current because the PMOS device behaves like a resistor in dropout.

As with any linear regulator, PSRR and transient response are degraded as $(V_{IN} - V_{OUT})$ approaches dropout. This effect is shown in the [Typical Characteristics](#) section (see [Figure 8](#) through [Figure 10](#)).

8.3.4 Start-up and Noise Reduction Capacitor

Fixed voltage versions of the TPS735 use a quick-start circuit to fast-charge the noise reduction capacitor, C_{NR} , if present (see the [Functional Block Diagrams](#)). This architecture allows the combination of very low output noise and fast start-up times. The NR pin is high impedance so a low-leakage C_{NR} capacitor must be used. Most ceramic capacitors are appropriate in this configuration. A high-quality, COG-type (NPO) dielectric ceramic capacitor is recommended for C_{NR} when used in environments where abrupt changes in temperature can occur.

For the fastest start-up, V_{IN} should be applied first, then the enable pin (EN) driven high. If EN is tied to IN, start-up is somewhat slower. Refer to the [Typical Applications](#) section. The quick-start switch is closed for approximately 135 μ s. To ensure that C_{NR} is fully charged during the quick-start time, use a capacitor with a value of no more than 0.01 μ F.

8.3.5 Transient Response

As with any regulator, increasing the size of the output capacitor reduces overshoot and undershoot magnitude but increases the transient response duration. In the adjustable version, adding C_{FF} between the OUT and FB pins improves stability and transient response performance. The transient response of the TPS735 family of devices is enhanced by an active pulldown that engages when the output overshoots by approximately 5% or more when the device is enabled. When enabled, the pull-down device behaves like a 400- Ω resistor to ground.

8.3.6 Undervoltage Lockout

The TPS735 family of devices uses an undervoltage lockout circuit to keep the output disabled until the internal circuitry is operating properly. The UVLO circuit has a deglitch feature so that the UVLO typically ignores undershoot transients on the input if the transients are less than 50 μ s in duration.

8.3.7 Minimum Load

The TPS735 family of devices is stable and well-behaved with no output load. To meet the specified accuracy, a minimum load of 500 μ A is required. Below 500 μ A and at junction temperatures near 125°C, the output can drift up enough to cause the output pulldown to turn on. The output pulldown limits voltage drift to 5% (typically) but ground current can increase by approximately 50 μ A. In most applications, the junction does not reach high temperatures at light loads because very little power is dissipated. Therefore, the specified ground current is valid at no load in most applications.

Feature Description (continued)

8.3.8 Thermal Protection

Thermal protection disables the output when the junction temperature rises to approximately 165°C, allowing the device to cool. When the junction temperature cools to approximately 145°C, the output circuitry is again enabled. Depending on power dissipation, thermal resistance, and ambient temperature, the thermal protection circuit can cycle on and off. This cycling limits the dissipation of the regulator, protecting it from damage as a result of overheating.

Any tendency to activate the thermal protection circuit indicates excessive power dissipation or an inadequate heatsink. For reliable operation, limit junction temperature to 125°C maximum. To estimate the thermal margin in a complete design (including heatsink), increase the ambient temperature until the thermal protection is triggered; use worst-case loads and signal conditions. For good reliability, trigger thermal protection at least 40°C above the maximum expected ambient condition of a particular application. This configuration produces a worst-case junction temperature of 125°C at the highest expected ambient temperature and worst-case load.

The internal protection circuitry of the TPS735 has been designed to protect against overload conditions. This protection circuitry is not intended to replace proper heatsinking. Continuously running the TPS735 into thermal shutdown degrades device reliability.

8.4 Device Functional Modes

8.4.1 Normal Operation

The device regulates to the nominal output voltage under the following conditions:

- The input voltage has previously exceeded the UVLO voltage and has not decreased below the UVLO threshold minus V_{hys} .
- The input voltage is greater than the nominal output voltage added to the dropout voltage.
- The enable voltage has previously exceeded the enable rising threshold voltage and has not decreased below the enable falling threshold.
- The output current is less than the current limit.
- The device junction temperature is in the specified range.

8.4.2 Dropout Operation

If the input voltage is lower than the nominal output voltage plus the specified dropout voltage, but all other conditions are met for normal operation, the device operates in dropout mode. In this condition, the output voltage is equal to the input voltage minus the dropout voltage. The transient performance of the device is significantly degraded because the pass device is in a triode state and the LDO behaves like a resistor. Line or load transients in dropout can result in large output voltage deviations.

8.4.3 Disabled

The device is disabled under the following conditions:

- The input voltage is less than the UVLO threshold minus V_{hys} , or has not yet exceeded the UVLO threshold.
- The enable voltage is less than the enable falling threshold voltage or has not yet exceeded the enable rising threshold.
- The device junction temperature is greater than the thermal shutdown temperature.

Table 1 lists the conditions that lead to the different modes of operation.

Table 1. Device Functional Mode Comparison

OPERATING MODE	PARAMETER			
	V_{IN}	V_{EN}	I_{OUT}	T_J
Normal mode	$V_{IN} > V_{OUTnom} + V_{DO}$ and $V_{IN} > UVLO$	$V_{EN} > V_{EN(HI)}$	$I_{OUT} < I_{LIM}$	$T_J < 125^{\circ}C$
Dropout mode	$UVLO < V_{IN} < V_{OUTnom} + V_{DO}$	$V_{EN} > V_{EN(HI)}$	—	$T_J < 165^{\circ}C$
Disabled mode (any true condition disables the device)	$V_{IN} < UVLO - V_{hys}$	$V_{EN} < V_{EN(LO)}$	—	$T_J > 165^{\circ}C$

9 Application and Implementation

NOTE

Information in the following applications sections is not part of the TI component specification, and TI does not warrant its accuracy or completeness. TI's customers are responsible for determining suitability of components for their purposes. Customers should validate and test their design implementation to confirm system functionality.

9.1 Application Information

The TPS735 family of LDO regulators provides a design with an ultra-low noise, high PSRR, low-dropout linear regulation with a very small ground current (46 μ A, typical).

The devices are stable with ceramic capacitors, and have a dropout voltage of 280 mV at the full output rating of 500 mA. The features of the TPS735 family of devices enables the LDO regulators to be suitable for a wide variety of applications, with minimal design complexity.

9.2 Typical Applications

Figure 15 shows the basic circuit connections for fixed-voltage models. Figure 16 shows the connections for the adjustable output version (TPS73501). R_1 and R_2 can be calculated for any output voltage using the formula in Figure 16.

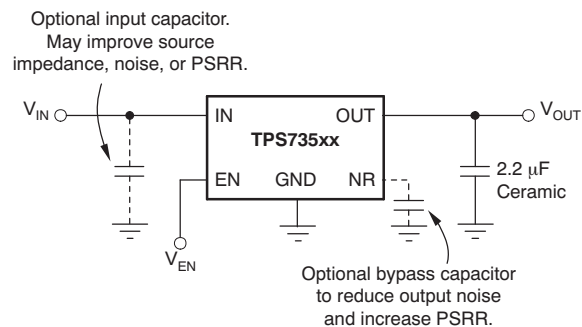

Figure 15. Typical Application Circuit for Fixed-Voltage Versions

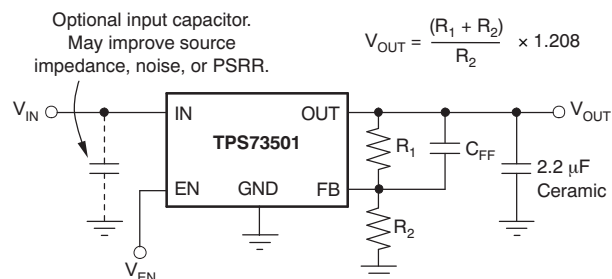

Figure 16. Typical Application Circuit for Adjustable-Voltage Versions

Typical Applications (continued)

9.2.1 Design Requirements

9.2.1.1 Input and Output Capacitor Requirements

Although an input capacitor is not required for stability, connecting a 0.1- μ F to 1- μ F low-equivalent series-resistance (ESR) capacitor across the input supply near the regulator is good analog design practice. This capacitor counteracts reactive input sources and improves transient response and ripple rejection. A higher-value capacitor can be necessary if large, fast, rise-time load transients are anticipated or if the device is located several inches from the power source. If source impedance is not sufficiently low, a 0.1- μ F input capacitor can be necessary to ensure stability.

The TPS735 family of devices is designed to be stable with standard ceramic output capacitors of values 2 μ F or larger. X5R- and X7R-type capacitors are best because they have minimal variation in value and ESR over temperature. Maximum ESR of the output capacitor is $< 1 \Omega$ and, therefore, the output capacitor type must either be ceramic or conductive polymer electrolytic.

9.2.1.2 Feed-Forward Capacitor Requirements (TPS73501 Only)

The feed-forward capacitor (C_{FF}), shown in [Figure 16](#), is required for stability. For a parallel combination of R_1 and R_2 equal to 250 k Ω , any value between 3 pF to 1 nF can be used. Fixed-voltage versions have an internal 30-pF feed-forward capacitor that is quick-charged at start-up. Larger value capacitors also improve noise slightly. The TPS73501 device is stable in unity-gain configurations (the OUT pin is tied to the FB pin) without C_{FF} .

9.2.2 Detailed Design Procedure

9.2.2.1 Output Noise

In most LDO regulators, the band gap is the dominant noise source. If a noise-reduction capacitor (C_{NR}) is used with the TPS735 family of devices, the band gap does not contribute significantly to noise. Instead, noise is dominated by the output-resistor divider and the error-amplifier input. To minimize noise in a given application, use a 10-nF noise reduction capacitor. For the adjustable version, smaller value resistors in the output resistor divider reduce noise. A parallel combination that gives 2 μ A of divider current has the same noise performance as a fixed voltage version with a C_{NR} . To further optimize noise, ESR of the output capacitor can be set to approximately 0.2 Ω . This configuration maximizes phase margin in the control loop, reducing the total output noise up to 10%. The maximum recommended capacitor is 10 nF.

[Equation 1](#) calculates the approximate integrated output noise from 10 Hz to 100 kHz with a C_{NR} value of 10 nF.

$$V_n (\mu V_{RMS}) = 11 (\mu V_{RMS} / V) \times V_{OUT} (V) \quad (1)$$

The TPS73501 adjustable version does not have the noise-reduction pin available, so ultra-low noise operation is not possible. Noise can be minimized according to the previously listed recommendations.

Typical Applications (continued)

9.2.3 Application Curves

At $V_{IN} = V_{OUT(nom)} + 0.5\text{ V}$ or 2.7 V , whichever is greater; $I_{OUT} = 1\text{ mA}$, $V_{EN} = V_{IN}$, $C_{OUT} = 2.2\text{ }\mu\text{F}$, $C_{NR} = 10\text{ nF}$, and $T_J = 25^\circ\text{C}$, unless otherwise noted.

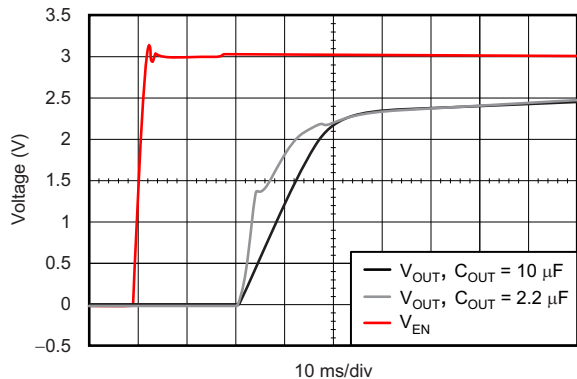

Figure 17. TPS73525 Turnon Response ($V_{IN} = V_{EN}$)

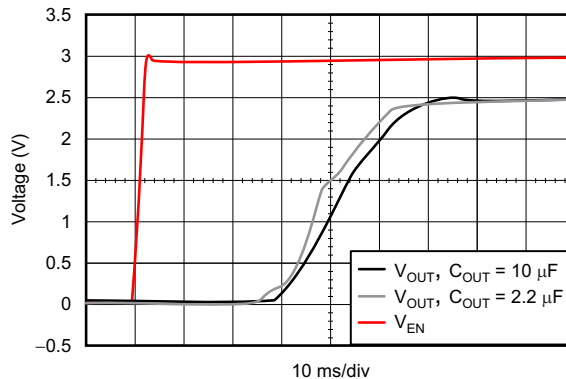

Figure 18. TPS73525 Turnon Response Using EN

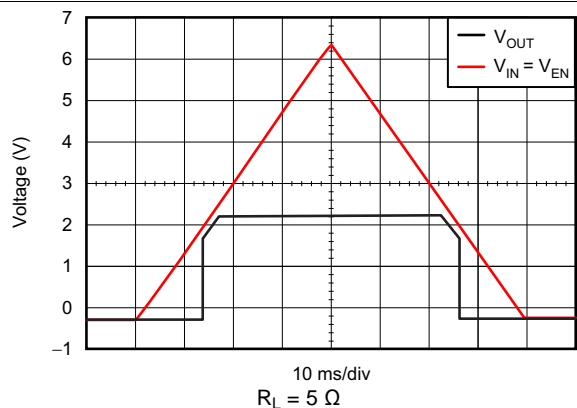

Figure 19. TPS73525 Power-Up and Power-Down ($V_{IN} = V_{EN}$)

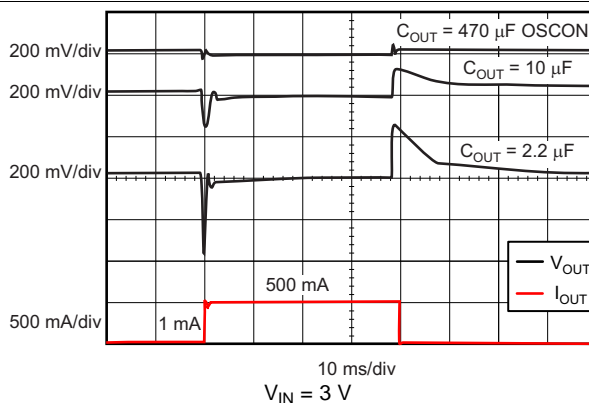

Figure 20. TPS73525 Load Transient Response

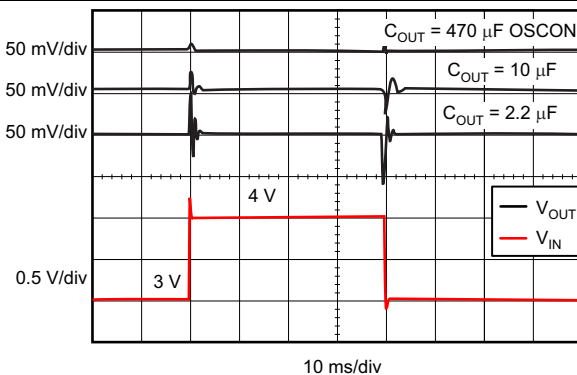

Figure 21. TPS73525 Line Transient Response

10 Power-Supply Recommendations

The device is designed to operate from an input voltage supply range between 2.7 V and 6.5 V. The input voltage range must provide adequate headroom in order for the device to have a regulated output. This input supply must be well regulated. If the input supply is noisy, additional input capacitors with low ESR can help improve output noise.

11 Layout

11.1 Layout Guidelines

For best overall performance, place all circuit components on the same side of the circuit board and as near as practical to the respective LDO pin connections. Place ground return connections to the input and output capacitor, and to the LDO ground pin as close to each other as possible, connected by a wide, component-side, copper surface. The use of vias and long traces to create LDO component connections is strongly discouraged and negatively affects system performance. This grounding and layout scheme minimizes inductive parasitics, and thereby reduces load-current transients, minimizes noise, and increases circuit stability. A ground reference plane is also recommended and is either embedded in the printed circuit board (PCB) itself or located on the bottom side of the PCB opposite the components. This reference plane serves to assure accuracy of the output voltage, shields the LDO from noise, and behaves similar to a thermal plane to spread (or sink) heat from the LDO device when connected to the exposed thermal pad. In most applications, this ground plane is necessary to meet thermal requirements.

11.1.1 Board Layout Recommendations to Improve PSRR and Noise Performance

To improve ac performance (such as PSRR, output noise, and transient response), designing the board with separate ground planes for V_{IN} and V_{OUT} is recommended, with each ground plane connected only at the GND pin of the device. In addition, the ground connection for the bypass capacitor must connect directly to the GND pin of the device.

11.2 Layout Example

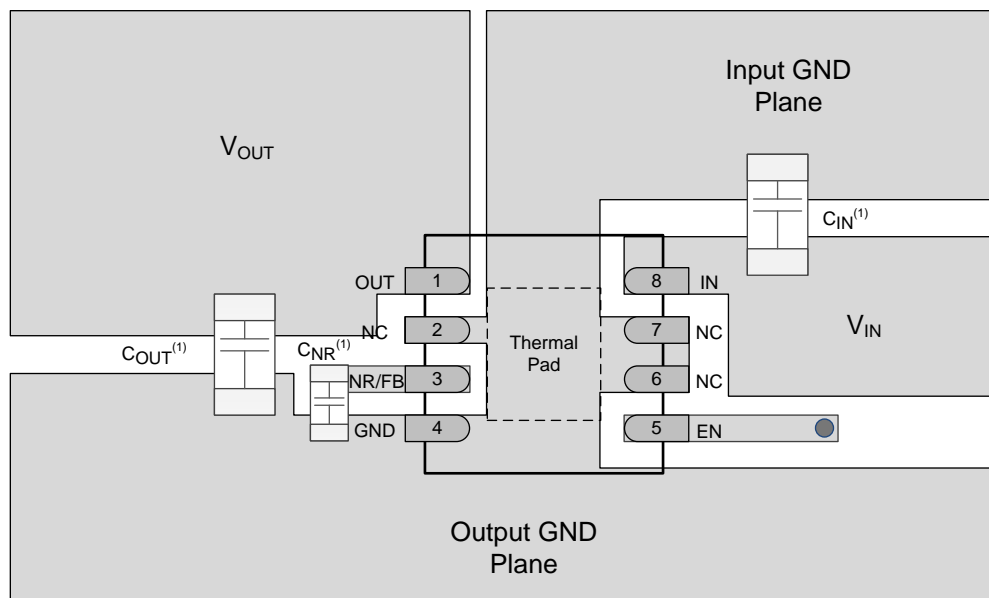

(1) C_{IN} and C_{OUT} are 0603 capacitors and C_{NR} is a 0402 capacitor. The footprint is shown to scale with package size.

Figure 22. TPS735 Fixed Version Layout Reference Diagram

11.3 Power Dissipation

The ability to remove heat from the die is different for each package type, presenting different considerations in the PCB layout. The PCB area around the device that is free of other components moves the heat from the device to the ambient air. Performance data for JEDEC low- and high-K boards are given in the [Thermal Information](#) table. Using heavier copper increases the effectiveness in removing heat from the device. The addition of plated through-holes to heat-dissipating layers also improves the heatsink effectiveness.

Power dissipation depends on input voltage and load conditions. Power dissipation can be approximated by the product of the product of the output current and the voltage drop across the output pass element, as shown in [Equation 2](#).

$$P_D = (V_{IN} - V_{OUT}) \times I_{OUT} \quad (2)$$

NOTE

When the device is used in a condition of high input and low output voltages, P_D can exceed the junction temperature rating even when the ambient temperature is at room temperature.

[Equation 3](#) is an example calculation for the power dissipation (P_D) of the DRB package.

$$P_D = (6.5 \text{ V} - 1.2 \text{ V}) \times 500 \text{ mA} = 2.65 \text{ W} \quad (3)$$

Power dissipation can be minimized and greater efficiency can be achieved by using the lowest possible input voltage necessary to achieve the required output performance.

On the DRB package, the primary conduction path for heat is through the exposed thermal pad to the PCB. The pad can be connected to ground or left floating; however, the pad must be attached to an appropriate amount of copper PCB area to ensure the device does not overheat. The maximum allowable junction-to-ambient thermal resistance depends on the maximum ambient temperature, maximum device junction temperature, and power dissipation of the device. Use [Equation 4](#) to calculate the maximum junction-to-ambient thermal resistance.

$$R_{\theta JA} = \frac{(125^\circ\text{C} - T_A)}{P_D} \quad (4)$$

Power Dissipation (continued)

Knowing the maximum $R_{\theta JA}$, the minimum amount of PCB copper area needed for appropriate heatsinking can be estimated using [Figure 23](#).

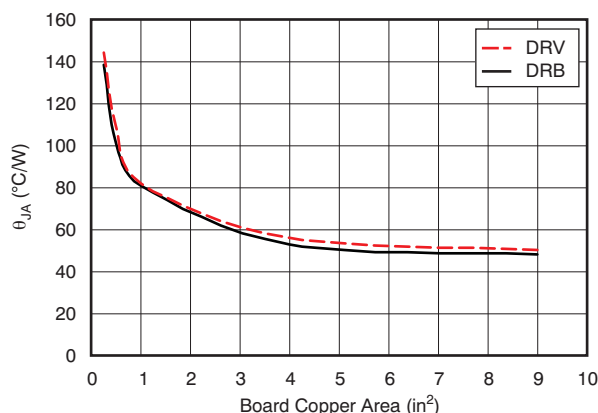

Note: θ_{JA} value at board size of 9 in² (that is, 3 in × 3 in) is a JEDEC standard.

Figure 23. θ_{JA} vs Board Size

[Figure 23](#) illustrates the variation of θ_{JA} as a function of ground plane copper area in the board. It is intended only as a guideline to demonstrate the effects of heat spreading in the ground plane and should not be used to estimate actual thermal performance in real application environments.

NOTE

When the device is mounted on an application PCB, it is strongly recommended to use Ψ_{JT} and Ψ_{JB} , as explained in the [Estimating Junction Temperature](#) section.

11.4 Estimating Junction Temperature

Using the thermal metrics Ψ_{JT} and Ψ_{JB} , as shown in the [Thermal Information](#) table, the junction temperature can be estimated with corresponding formulas (given in [Equation 5](#)), which are more accurate than the value of T_J through calculation with θ_{JA} .

$$\Psi_{JT}: T_J = T_T + \Psi_{JT} \cdot P_D$$

$$\Psi_{JB}: T_J = T_B + \Psi_{JB} \cdot P_D$$

where:

- P_D is the power dissipation calculated with [Equation 2](#),
- T_T is the temperature at the center-top of the device package, and
- T_B is the PCB temperature measured 1 mm away from the device package on the PCB surface (as shown in [Figure 25](#)). (5)

NOTE

Both T_T and T_B can be measured on actual application boards using a thermo-gun (an infrared thermometer).

For more information about measuring T_T and T_B , see the application note [SBVA025, Using New Thermal Metrics](#), available for download at www.ti.com.

Estimating Junction Temperature (continued)

According to Figure 24, the new thermal metrics (Ψ_{JT} and Ψ_{JB}) have very little dependency on copper area. Using Ψ_{JT} or Ψ_{JB} with Equation 5 is a good way to estimate T_J by simply measuring T_T or T_B on an application board.

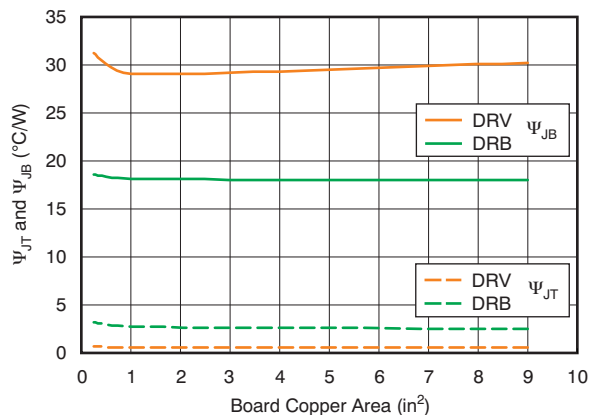
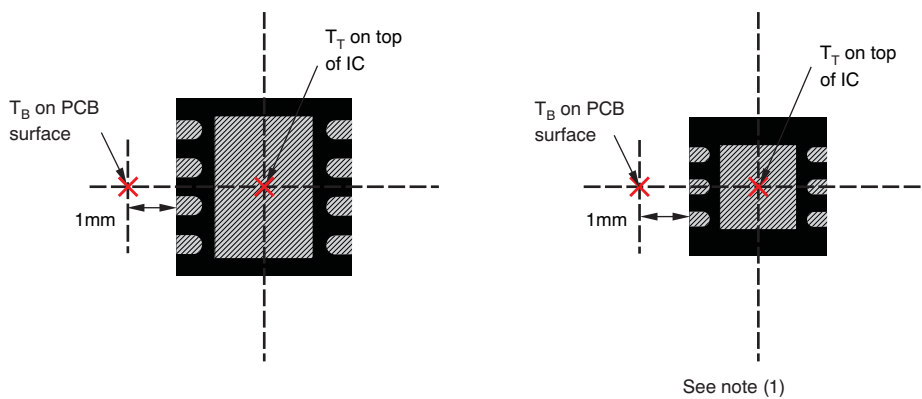

Figure 24. Ψ_{JT} and Ψ_{JB} vs Board Size



(a) Example DRB (SON) Package Measurement

(b) Example DRV (SON) Package Measurement

(1) Power dissipation may limit operating range. Check *Thermal Information* table.

Figure 25. Measuring Points for T_T and T_B

11.5 Package Mounting

Solder pad footprint recommendations for the TPS735 family of devices are available from the TI website at www.ti.com.

12 Device and Documentation Support

12.1 Device Support

12.1.1 Development Support

12.1.1.1 Evaluation Modules

Two evaluation modules (EVMs) are available to assist in the initial circuit performance evaluation using the TPS735. The [TPS73501EVM-276 evaluation module](#) and the [TPS73525EVM-276 Evaluation Module](#) (and related [user guide](#)) can be requested at the TI website through the product folders or purchased directly from the [TI eStore](#).

12.1.2 Device Nomenclature

Table 2. Device Nomenclature⁽¹⁾

PRODUCT	V _{OUT}
TPS735xx(x)yyyz	<p>xx(x) is the nominal output voltage. For output voltages with a resolution of 100 mV, two digits are used in the ordering number; otherwise, three digits are used (for example, 33 = 3.3 V; 125 = 1.25 V).</p> <p>yyy is the package designator.</p> <p>z is the tape and reel quantity (R = 3000, T = 250).</p> <p>01 is the adjustable version.</p>

(1) For the most current package and ordering information see the Package Option Addendum at the end of this document, or see the TI web site at www.ti.com.

12.2 Documentation Support

12.2.1 Related Documentation

For related documentation, see the following:

- Application note. *IC Package Thermal Metrics*. Literature number [SPRA953](#).
- Application note. *Using New Thermal Metrics*. Literature number [SBVA025](#).
- TPS735EVM-276 User Guide. Literature number [SLVU256](#).

12.3 Trademarks

WiFi is a registered trademark of WiFi Alliance.
All other trademarks are the property of their respective owners.

12.4 Electrostatic Discharge Caution



This integrated circuit can be damaged by ESD. Texas Instruments recommends that all integrated circuits be handled with appropriate precautions. Failure to observe proper handling and installation procedures can cause damage.

ESD damage can range from subtle performance degradation to complete device failure. Precision integrated circuits may be more susceptible to damage because very small parametric changes could cause the device not to meet its published specifications.

12.5 Glossary

[SLYZ022](#) — *TI Glossary*.

This glossary lists and explains terms, acronyms, and definitions.

13 Mechanical, Packaging, and Orderable Information

The following pages include mechanical, packaging, and orderable information. This information is the most current data available for the designated devices. This data is subject to change without notice and revision of this document. For browser-based versions of this data sheet, refer to the left-hand navigation.

PACKAGING INFORMATION

Orderable Device	Status (1)	Package Type	Package Drawing	Pins	Package Qty	Eco Plan (2)	Lead/Ball Finish (6)	MSL Peak Temp (3)	Op Temp (°C)	Device Marking (4/5)	Samples
TPS73501DRBR	ACTIVE	SON	DRB	8	3000	Green (RoHS & no Sb/Br)	CU NIPDAU	Level-2-260C-1 YEAR	-40 to 125	CBK	Samples
TPS73501DRBT	ACTIVE	SON	DRB	8	250	Green (RoHS & no Sb/Br)	CU NIPDAU	Level-2-260C-1 YEAR	-40 to 125	CBK	Samples
TPS73501DRVR	ACTIVE	SON	DRV	6	3000	Green (RoHS & no Sb/Br)	CU NIPDAU	Level-1-260C-UNLIM	-40 to 125	SDR	Samples
TPS73501DRVT	ACTIVE	SON	DRV	6	250	Green (RoHS & no Sb/Br)	CU NIPDAU	Level-1-260C-UNLIM	-40 to 125	SDR	Samples
TPS73512DRBR	ACTIVE	SON	DRB	8	3000	Green (RoHS & no Sb/Br)	CU NIPDAU	Level-2-260C-1 YEAR	-40 to 125	QTT	Samples
TPS73512DRBT	ACTIVE	SON	DRB	8	250	Green (RoHS & no Sb/Br)	CU NIPDAU	Level-2-260C-1 YEAR	-40 to 125	QTT	Samples
TPS73515DRBR	ACTIVE	SON	DRB	8	3000	Green (RoHS & no Sb/Br)	CU NIPDAU	Level-2-260C-1 YEAR	-40 to 125	QWH	Samples
TPS73515DRBT	ACTIVE	SON	DRB	8	250	Green (RoHS & no Sb/Br)	CU NIPDAU	Level-2-260C-1 YEAR	-40 to 125	QWH	Samples
TPS73525DRBR	ACTIVE	SON	DRB	8	3000	Green (RoHS & no Sb/Br)	CU NIPDAU	Level-2-260C-1 YEAR	-40 to 125	CBM	Samples
TPS73525DRBRG4	ACTIVE	SON	DRB	8	3000	Green (RoHS & no Sb/Br)	CU NIPDAU	Level-2-260C-1 YEAR	-40 to 125	CBM	Samples
TPS73525DRBT	ACTIVE	SON	DRB	8	250	Green (RoHS & no Sb/Br)	CU NIPDAU	Level-2-260C-1 YEAR	-40 to 125	CBM	Samples
TPS73525DRVR	ACTIVE	SON	DRV	6	3000	Green (RoHS & no Sb/Br)	CU NIPDAU	Level-1-260C-UNLIM	-40 to 125	NSW	Samples
TPS73525DRVT	ACTIVE	SON	DRV	6	250	Green (RoHS & no Sb/Br)	CU NIPDAU	Level-1-260C-UNLIM	-40 to 125	NSW	Samples
TPS73527DRVR	ACTIVE	SON	DRV	6	3000	Green (RoHS & no Sb/Br)	CU NIPDAU	Level-1-260C-UNLIM	-40 to 125	RAK	Samples
TPS73527DRVT	ACTIVE	SON	DRV	6	250	Green (RoHS & no Sb/Br)	CU NIPDAU	Level-1-260C-UNLIM	-40 to 125	RAK	Samples
TPS735285DRVR	ACTIVE	SON	DRV	6	3000	Green (RoHS & no Sb/Br)	CU NIPDAU	Level-1-260C-UNLIM	-40 to 125	RAW	Samples
TPS735285DRVT	ACTIVE	SON	DRV	6	250	Green (RoHS & no Sb/Br)	CU NIPDAU	Level-1-260C-UNLIM	-40 to 125	RAW	Samples

Orderable Device	Status (1)	Package Type	Package Drawing	Pins	Package Qty	Eco Plan (2)	Lead/Ball Finish (6)	MSL Peak Temp (3)	Op Temp (°C)	Device Marking (4/5)	Samples
TPS73533DRBR	ACTIVE	SON	DRB	8	3000	Green (RoHS & no Sb/Br)	CU NIPDAU	Level-2-260C-1 YEAR	-40 to 125	CVY	Samples
TPS73533DRBT	ACTIVE	SON	DRB	8	250	Green (RoHS & no Sb/Br)	CU NIPDAU	Level-2-260C-1 YEAR	-40 to 125	CVY	Samples
TPS73533DRVR	ACTIVE	SON	DRV	6	3000	Green (RoHS & no Sb/Br)	CU NIPDAU	Level-1-260C-UNLIM	-40 to 125	CVY	Samples
TPS73533DRVT	ACTIVE	SON	DRV	6	250	Green (RoHS & no Sb/Br)	CU NIPDAU	Level-1-260C-UNLIM	-40 to 125	CVY	Samples

(1) The marketing status values are defined as follows:

ACTIVE: Product device recommended for new designs.

LIFEBUY: TI has announced that the device will be discontinued, and a lifetime-buy period is in effect.

NRND: Not recommended for new designs. Device is in production to support existing customers, but TI does not recommend using this part in a new design.

PREVIEW: Device has been announced but is not in production. Samples may or may not be available.

OBSOLETE: TI has discontinued the production of the device.

(2) Eco Plan - The planned eco-friendly classification: Pb-Free (RoHS), Pb-Free (RoHS Exempt), or Green (RoHS & no Sb/Br) - please check <http://www.ti.com/productcontent> for the latest availability information and additional product content details.

TBD: The Pb-Free/Green conversion plan has not been defined.

Pb-Free (RoHS): TI's terms "Lead-Free" or "Pb-Free" mean semiconductor products that are compatible with the current RoHS requirements for all 6 substances, including the requirement that lead not exceed 0.1% by weight in homogeneous materials. Where designed to be soldered at high temperatures, TI Pb-Free products are suitable for use in specified lead-free processes.

Pb-Free (RoHS Exempt): This component has a RoHS exemption for either 1) lead-based flip-chip solder bumps used between the die and package, or 2) lead-based die adhesive used between the die and leadframe. The component is otherwise considered Pb-Free (RoHS compatible) as defined above.

Green (RoHS & no Sb/Br): TI defines "Green" to mean Pb-Free (RoHS compatible), and free of Bromine (Br) and Antimony (Sb) based flame retardants (Br or Sb do not exceed 0.1% by weight in homogeneous material)

(3) MSL, Peak Temp. - The Moisture Sensitivity Level rating according to the JEDEC industry standard classifications, and peak solder temperature.

(4) There may be additional marking, which relates to the logo, the lot trace code information, or the environmental category on the device.

(5) Multiple Device Markings will be inside parentheses. Only one Device Marking contained in parentheses and separated by a "~" will appear on a device. If a line is indented then it is a continuation of the previous line and the two combined represent the entire Device Marking for that device.

(6) Lead/Ball Finish - Orderable Devices may have multiple material finish options. Finish options are separated by a vertical ruled line. Lead/Ball Finish values may wrap to two lines if the finish value exceeds the maximum column width.

Important Information and Disclaimer: The information provided on this page represents TI's knowledge and belief as of the date that it is provided. TI bases its knowledge and belief on information provided by third parties, and makes no representation or warranty as to the accuracy of such information. Efforts are underway to better integrate information from third parties. TI has taken and

continues to take reasonable steps to provide representative and accurate information but may not have conducted destructive testing or chemical analysis on incoming materials and chemicals. TI and TI suppliers consider certain information to be proprietary, and thus CAS numbers and other limited information may not be available for release.

In no event shall TI's liability arising out of such information exceed the total purchase price of the TI part(s) at issue in this document sold by TI to Customer on an annual basis.

TAPE AND REEL INFORMATION

QUADRANT ASSIGNMENTS FOR PIN 1 ORIENTATION IN TAPE

*All dimensions are nominal

Device	Package Type	Package Drawing	Pins	SPQ	Reel Diameter (mm)	Reel Width W1 (mm)	A0 (mm)	B0 (mm)	K0 (mm)	P1 (mm)	W (mm)	Pin1 Quadrant
TPS73501DRBR	SON	DRB	8	3000	330.0	12.4	3.3	3.3	1.1	8.0	12.0	Q2
TPS73501DRBT	SON	DRB	8	250	180.0	12.5	3.3	3.3	1.1	8.0	12.0	Q2
TPS73501DRVR	SON	DRV	6	3000	179.0	8.4	2.2	2.2	1.2	4.0	8.0	Q2
TPS73501DRVR	SON	DRV	6	3000	180.0	8.4	2.25	2.25	1.0	4.0	8.0	Q2
TPS73501DRVT	SON	DRV	6	250	179.0	8.4	2.2	2.2	1.2	4.0	8.0	Q2
TPS73501DRVT	SON	DRV	6	250	180.0	8.4	2.25	2.25	1.0	4.0	8.0	Q2
TPS73512DRBR	SON	DRB	8	3000	330.0	12.4	3.3	3.3	1.1	8.0	12.0	Q2
TPS73512DRBT	SON	DRB	8	250	180.0	12.4	3.3	3.3	1.1	8.0	12.0	Q2
TPS73515DRBR	SON	DRB	8	3000	330.0	12.4	3.3	3.3	1.1	8.0	12.0	Q2
TPS73515DRBT	SON	DRB	8	250	180.0	12.5	3.3	3.3	1.1	8.0	12.0	Q2
TPS73525DRBR	SON	DRB	8	3000	330.0	12.4	3.3	3.3	1.1	8.0	12.0	Q2
TPS73525DRBT	SON	DRB	8	250	180.0	12.5	3.3	3.3	1.1	8.0	12.0	Q2
TPS73525DRVR	SON	DRV	6	3000	179.0	8.4	2.2	2.2	1.2	4.0	8.0	Q2
TPS73525DRVT	SON	DRV	6	250	179.0	8.4	2.2	2.2	1.2	4.0	8.0	Q2
TPS73527DRVR	SON	DRV	6	3000	180.0	8.4	2.25	2.25	1.0	4.0	8.0	Q2
TPS73527DRVR	SON	DRV	6	3000	179.0	8.4	2.2	2.2	1.2	4.0	8.0	Q2
TPS73527DRVT	SON	DRV	6	250	179.0	8.4	2.2	2.2	1.2	4.0	8.0	Q2
TPS735285DRVR	SON	DRV	6	3000	179.0	8.4	2.2	2.2	1.2	4.0	8.0	Q2

Device	Package Type	Package Drawing	Pins	SPQ	Reel Diameter (mm)	Reel Width W1 (mm)	A0 (mm)	B0 (mm)	K0 (mm)	P1 (mm)	W (mm)	Pin1 Quadrant
TPS735285DRVT	SON	DRV	6	250	179.0	8.4	2.2	2.2	1.2	4.0	8.0	Q2
TPS73533DRBR	SON	DRB	8	3000	330.0	12.4	3.3	3.3	1.1	8.0	12.0	Q2
TPS73533DRBT	SON	DRB	8	250	180.0	12.5	3.3	3.3	1.1	8.0	12.0	Q2
TPS73533DRVR	SON	DRV	6	3000	179.0	8.4	2.2	2.2	1.2	4.0	8.0	Q2
TPS73533DRVT	SON	DRV	6	250	179.0	8.4	2.2	2.2	1.2	4.0	8.0	Q2

TAPE AND REEL BOX DIMENSIONS



*All dimensions are nominal

Device	Package Type	Package Drawing	Pins	SPQ	Length (mm)	Width (mm)	Height (mm)
TPS73501DRBR	SON	DRB	8	3000	338.0	355.0	50.0
TPS73501DRBT	SON	DRB	8	250	338.0	355.0	50.0
TPS73501DRVR	SON	DRV	6	3000	203.0	203.0	35.0
TPS73501DRVR	SON	DRV	6	3000	205.0	200.0	33.0
TPS73501DRVT	SON	DRV	6	250	203.0	203.0	35.0
TPS73501DRVT	SON	DRV	6	250	205.0	200.0	33.0
TPS73512DRBR	SON	DRB	8	3000	367.0	367.0	35.0
TPS73512DRBT	SON	DRB	8	250	210.0	185.0	35.0
TPS73515DRBR	SON	DRB	8	3000	338.0	355.0	50.0
TPS73515DRBT	SON	DRB	8	250	338.0	355.0	50.0
TPS73525DRBR	SON	DRB	8	3000	338.0	355.0	50.0
TPS73525DRBT	SON	DRB	8	250	338.0	355.0	50.0

Device	Package Type	Package Drawing	Pins	SPQ	Length (mm)	Width (mm)	Height (mm)
TPS73525DRVR	SON	DRV	6	3000	203.0	203.0	35.0
TPS73525DRVT	SON	DRV	6	250	203.0	203.0	35.0
TPS73527DRVR	SON	DRV	6	3000	205.0	200.0	33.0
TPS73527DRVR	SON	DRV	6	3000	203.0	203.0	35.0
TPS73527DRVT	SON	DRV	6	250	203.0	203.0	35.0
TPS735285DRVR	SON	DRV	6	3000	203.0	203.0	35.0
TPS735285DRVT	SON	DRV	6	250	203.0	203.0	35.0
TPS73533DRBR	SON	DRB	8	3000	338.0	355.0	50.0
TPS73533DRBT	SON	DRB	8	250	338.0	355.0	50.0
TPS73533DRVR	SON	DRV	6	3000	203.0	203.0	35.0
TPS73533DRVT	SON	DRV	6	250	203.0	203.0	35.0

DRB (S-PVSON-N8)

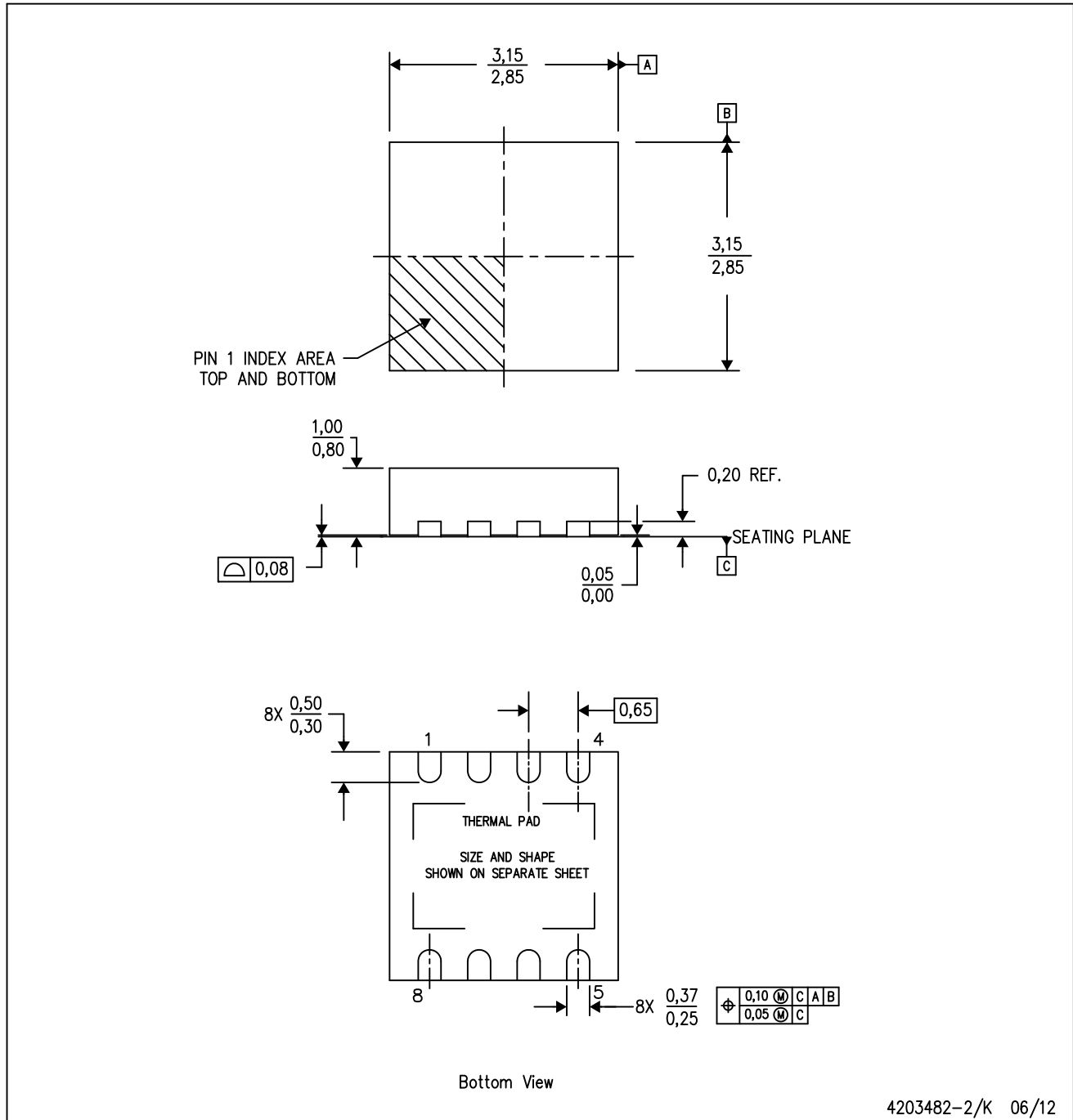
PLASTIC SMALL OUTLINE NO-LEAD



4203482-2/K 06/12

- NOTES:
- All linear dimensions are in millimeters. Dimensioning and tolerancing per ASME Y14.5M-1994.
 - This drawing is subject to change without notice.
 - Small Outline No-Lead (SON) package configuration.
 - The package thermal pad must be soldered to the board for thermal and mechanical performance.
 - See the additional figure in the Product Data Sheet for details regarding the exposed thermal pad features and dimensions.

THERMAL INFORMATION

This package incorporates an exposed thermal pad that is designed to be attached directly to an external heatsink. The thermal pad must be soldered directly to the printed circuit board (PCB). After soldering, the PCB can be used as a heatsink. In addition, through the use of thermal vias, the thermal pad can be attached directly to the appropriate copper plane shown in the electrical schematic for the device, or alternatively, can be attached to a special heatsink structure designed into the PCB. This design optimizes the heat transfer from the integrated circuit (IC).

For information on the Quad Flatpack No-Lead (QFN) package and its advantages, refer to Application Report, QFN/SON PCB Attachment, Texas Instruments Literature No. SLUA271. This document is available at www.ti.com.

The exposed thermal pad dimensions for this package are shown in the following illustration.

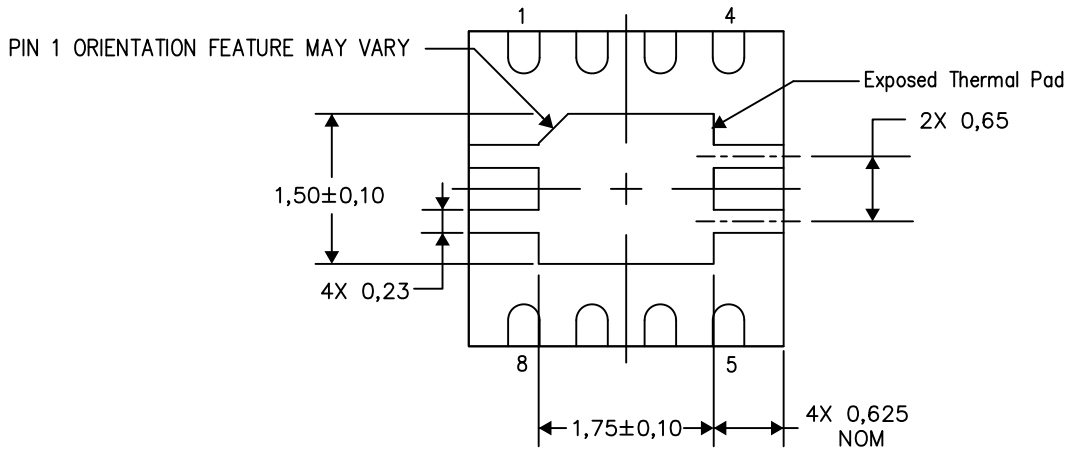

Bottom View

Exposed Thermal Pad Dimensions

4206340-2/P 07/14

NOTE: All linear dimensions are in millimeters

DRB (S-PVSON-N8)

PLASTIC SMALL OUTLINE NO-LEAD

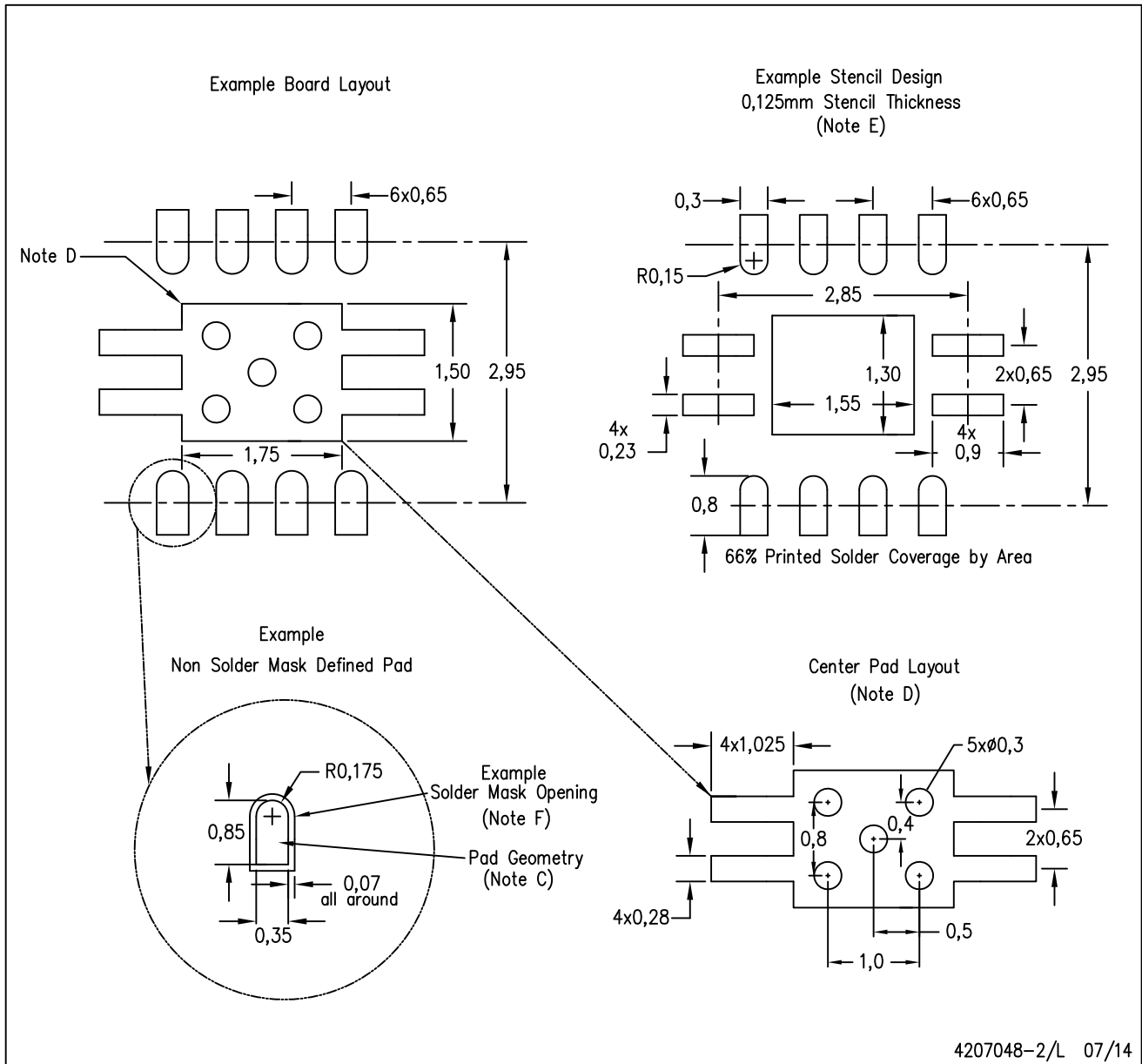

- NOTES:
- All linear dimensions are in millimeters.
 - This drawing is subject to change without notice.
 - Publication IPC-7351 is recommended for alternate designs.
 - This package is designed to be soldered to a thermal pad on the board. Refer to Application Note, QFN Packages, Texas Instruments Literature No. SLUA271, and also the Product Data Sheets for specific thermal information, via requirements, and recommended board layout. These documents are available at www.ti.com <<http://www.ti.com>>.
 - Laser cutting apertures with trapezoidal walls and also rounding corners will offer better paste release. Customers should contact their board assembly site for stencil design recommendations. Refer to IPC 7525 for stencil design considerations.
 - Customers should contact their board fabrication site for solder mask tolerances.

MECHANICAL DATA

DRV (S-PWSON-N6)

PLASTIC SMALL OUTLINE NO-LEAD

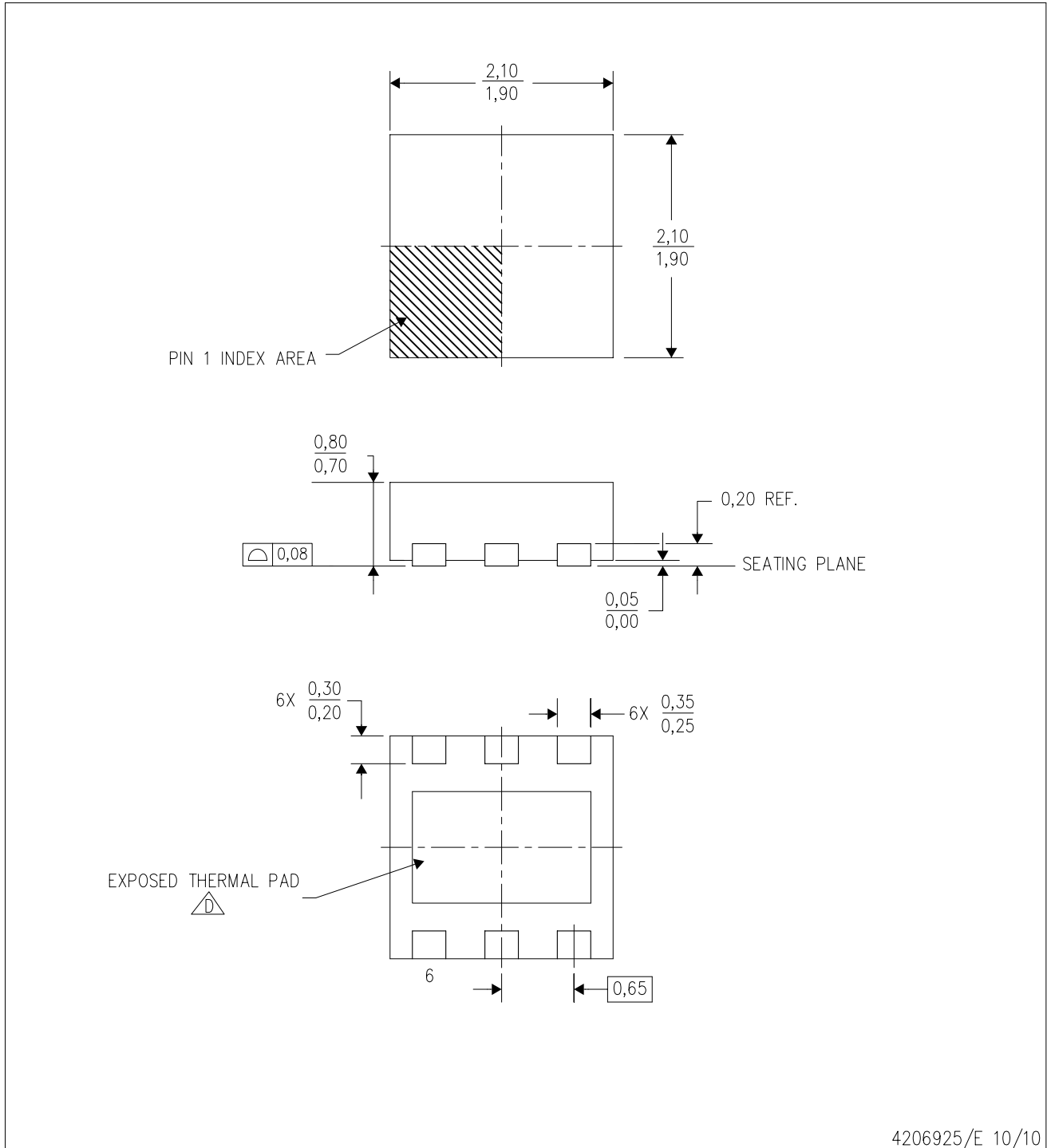

4206925/E 10/10

- NOTES:
- All linear dimensions are in millimeters. Dimensioning and tolerancing per ASME Y14.5M-1994.
 - This drawing is subject to change without notice.
 - Small Outline No-Lead (SON) package configuration.
-  The package thermal pad must be soldered to the board for thermal and mechanical performance. See the Product Data Sheet for details regarding the exposed thermal pad dimensions.

THERMAL PAD MECHANICAL DATA

DRV (S-PWSON-N6)

PLASTIC SMALL OUTLINE NO-LEAD

THERMAL INFORMATION

This package incorporates an exposed thermal pad that is designed to be attached directly to an external heatsink. The thermal pad must be soldered directly to the printed circuit board (PCB). After soldering, the PCB can be used as a heatsink. In addition, through the use of thermal vias, the thermal pad can be attached directly to the appropriate copper plane shown in the electrical schematic for the device, or alternatively, can be attached to a special heatsink structure designed into the PCB. This design optimizes the heat transfer from the integrated circuit (IC).

For information on the Quad Flatpack No-Lead (QFN) package and its advantages, refer to Application Report, QFN/SON PCB Attachment, Texas Instruments Literature No. SLUA271. This document is available at www.ti.com.

The exposed thermal pad dimensions for this package are shown in the following illustration.

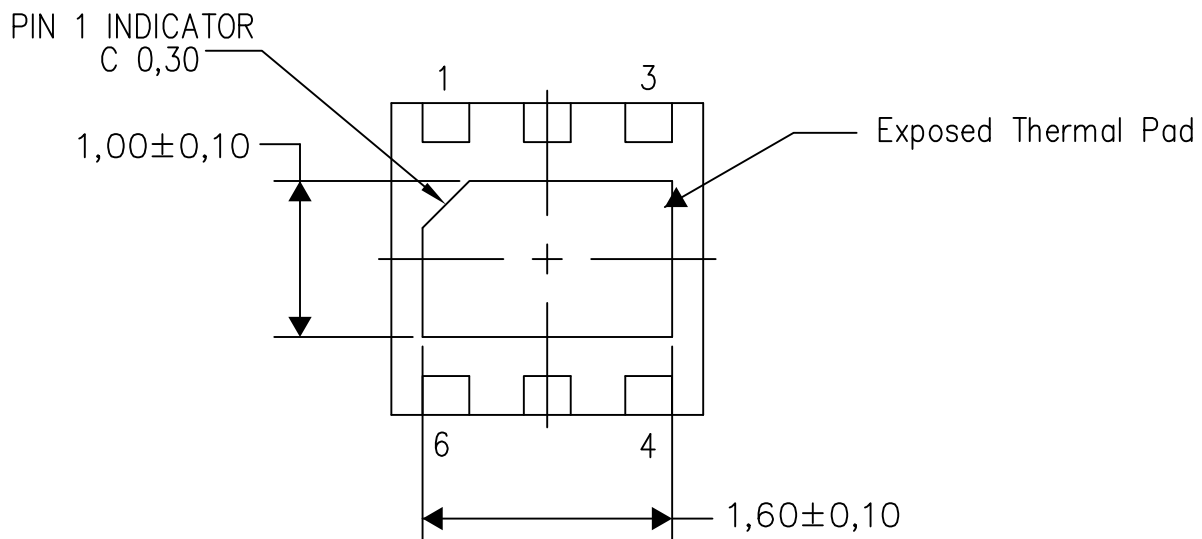

Bottom View

Exposed Thermal Pad Dimensions

4206926/0 01/14

NOTE: All linear dimensions are in millimeters

DRV (S-PWSON-N6)

PLASTIC SMALL OUTLINE NO-LEAD

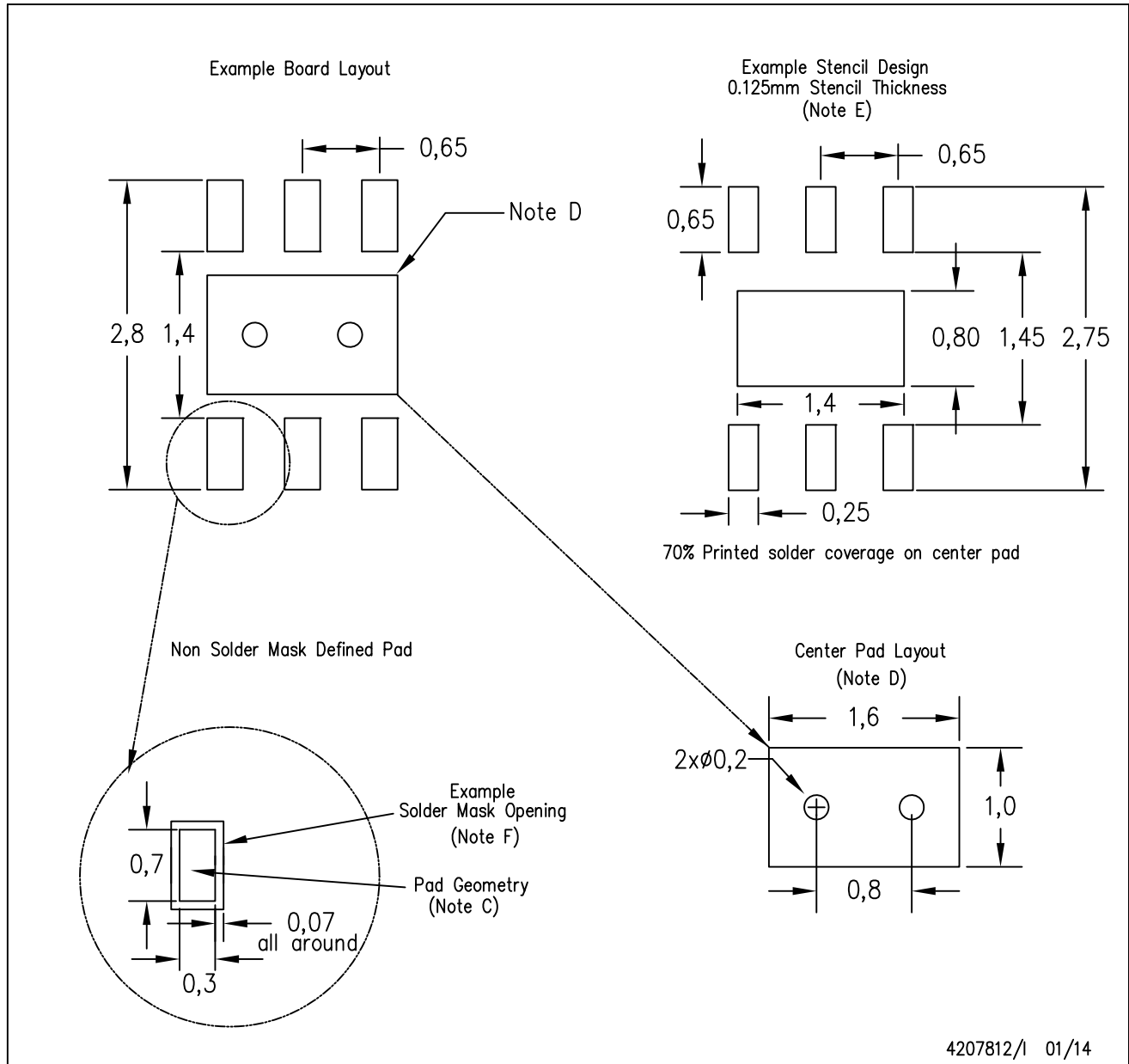

- NOTES:
- All linear dimensions are in millimeters.
 - This drawing is subject to change without notice.
 - Publication IPC-7351 is recommended for alternate designs.
 - This package is designed to be soldered to a thermal pad on the board. Refer to Application Note, QFN/SON PCB Attachment, Texas Instruments Literature No. SLUA271, and also the Product Data Sheets for specific thermal information, via requirements, and recommended board layout. These documents are available at www.ti.com <<http://www.ti.com>>.
 - Laser cutting apertures with trapezoidal walls and also rounding corners will offer better paste release. Customers should contact their board assembly site for stencil design recommendations. Refer to IPC 7525 for stencil design considerations.
 - Customers should contact their board fabrication site for solder mask tolerances.

IMPORTANT NOTICE

Texas Instruments Incorporated and its subsidiaries (TI) reserve the right to make corrections, enhancements, improvements and other changes to its semiconductor products and services per JESD46, latest issue, and to discontinue any product or service per JESD48, latest issue. Buyers should obtain the latest relevant information before placing orders and should verify that such information is current and complete. All semiconductor products (also referred to herein as "components") are sold subject to TI's terms and conditions of sale supplied at the time of order acknowledgment.

TI warrants performance of its components to the specifications applicable at the time of sale, in accordance with the warranty in TI's terms and conditions of sale of semiconductor products. Testing and other quality control techniques are used to the extent TI deems necessary to support this warranty. Except where mandated by applicable law, testing of all parameters of each component is not necessarily performed.

TI assumes no liability for applications assistance or the design of Buyers' products. Buyers are responsible for their products and applications using TI components. To minimize the risks associated with Buyers' products and applications, Buyers should provide adequate design and operating safeguards.

TI does not warrant or represent that any license, either express or implied, is granted under any patent right, copyright, mask work right, or other intellectual property right relating to any combination, machine, or process in which TI components or services are used. Information published by TI regarding third-party products or services does not constitute a license to use such products or services or a warranty or endorsement thereof. Use of such information may require a license from a third party under the patents or other intellectual property of the third party, or a license from TI under the patents or other intellectual property of TI.

Reproduction of significant portions of TI information in TI data books or data sheets is permissible only if reproduction is without alteration and is accompanied by all associated warranties, conditions, limitations, and notices. TI is not responsible or liable for such altered documentation. Information of third parties may be subject to additional restrictions.

Resale of TI components or services with statements different from or beyond the parameters stated by TI for that component or service voids all express and any implied warranties for the associated TI component or service and is an unfair and deceptive business practice. TI is not responsible or liable for any such statements.

Buyer acknowledges and agrees that it is solely responsible for compliance with all legal, regulatory and safety-related requirements concerning its products, and any use of TI components in its applications, notwithstanding any applications-related information or support that may be provided by TI. Buyer represents and agrees that it has all the necessary expertise to create and implement safeguards which anticipate dangerous consequences of failures, monitor failures and their consequences, lessen the likelihood of failures that might cause harm and take appropriate remedial actions. Buyer will fully indemnify TI and its representatives against any damages arising out of the use of any TI components in safety-critical applications.

In some cases, TI components may be promoted specifically to facilitate safety-related applications. With such components, TI's goal is to help enable customers to design and create their own end-product solutions that meet applicable functional safety standards and requirements. Nonetheless, such components are subject to these terms.

No TI components are authorized for use in FDA Class III (or similar life-critical medical equipment) unless authorized officers of the parties have executed a special agreement specifically governing such use.

Only those TI components which TI has specifically designated as military grade or "enhanced plastic" are designed and intended for use in military/aerospace applications or environments. Buyer acknowledges and agrees that any military or aerospace use of TI components which have **not** been so designated is solely at the Buyer's risk, and that Buyer is solely responsible for compliance with all legal and regulatory requirements in connection with such use.

TI has specifically designated certain components as meeting ISO/TS16949 requirements, mainly for automotive use. In any case of use of non-designated products, TI will not be responsible for any failure to meet ISO/TS16949.

Products

Audio	www.ti.com/audio
Amplifiers	amplifier.ti.com
Data Converters	dataconverter.ti.com
DLP® Products	www.dlp.com
DSP	dsp.ti.com
Clocks and Timers	www.ti.com/clocks
Interface	interface.ti.com
Logic	logic.ti.com
Power Mgmt	power.ti.com
Microcontrollers	microcontroller.ti.com
RFID	www.ti-rfid.com
OMAP Applications Processors	www.ti.com/omap
Wireless Connectivity	www.ti.com/wirelessconnectivity

Applications

Automotive and Transportation	www.ti.com/automotive
Communications and Telecom	www.ti.com/communications
Computers and Peripherals	www.ti.com/computers
Consumer Electronics	www.ti.com/consumer-apps
Energy and Lighting	www.ti.com/energy
Industrial	www.ti.com/industrial
Medical	www.ti.com/medical
Security	www.ti.com/security
Space, Avionics and Defense	www.ti.com/space-avionics-defense
Video and Imaging	www.ti.com/video

TI E2E Community

e2e.ti.com