

## DC-DC INVERTER

 Check for Samples: [TPS63700](#)

### FEATURES

- Adjustable Output Voltage Down to  $-15\text{ V}$
- 2.7-V to 5.5-V Input Voltage Range
- Up to 360-mA Output Current
- 1000-mA Typical Switch Current Limit
- Up to 84% Efficiency
- Typical 1.4-MHz Fixed-Frequency PWM Operation
- Thermal Shutdown
- Typical  $-19\text{ V}$  Output Overvoltage Protection
- $1.5\text{-}\mu\text{A}$  Shutdown Current
- Small 3-mm x 3-mm SON-10 Package (DRC)

### APPLICATIONS

- Generic Negative Voltage Supply
- Small-to-Medium Size OLED Displays
- PDAs, Pocket PCs, Smartphones
- Bias Supply

### DESCRIPTION

The TPS63700 is an inverting dc-dc converter generating a negative output voltage down to  $-15\text{ V}$  with output currents up to 360-mA, depending on input-voltage to output-voltage ratio. With a total efficiency up to 84%, the device is ideal for portable battery-powered equipment. The input voltage range of 2.7-V to 5.5-V allows the TPS63700 to be directly powered from a Li-ion battery, from 3-cell NiMH/NiCd, from a 3.3-V or 5-V supply rail. The TPS63700 comes in a small 3-mm x 3-mm SON-10 package. Furthermore, the high switching frequency of typically 1.4 MHz allows the use of small external components. This, and the small package make a small power supply solution possible.

The inverter operates with a fixed-frequency PWM control topology. The device has an internal current limit, overvoltage protection, and a thermal shutdown for highest reliability under fault conditions.

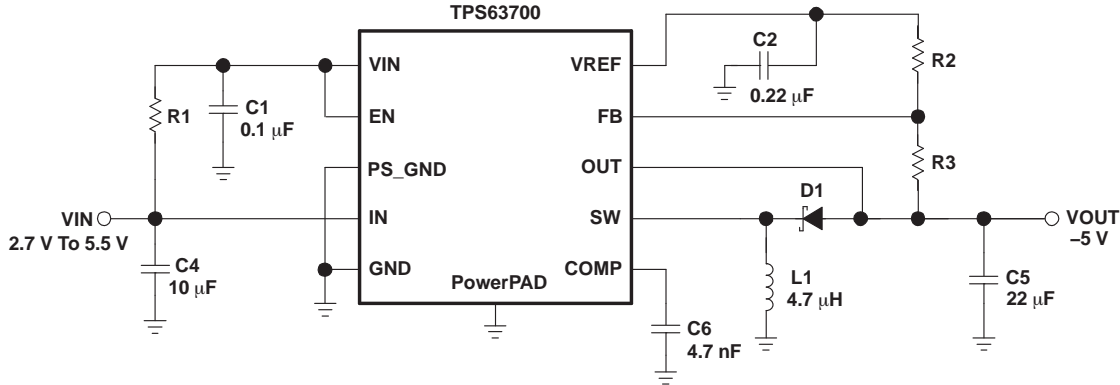

Please be aware that an important notice concerning availability, standard warranty, and use in critical applications of Texas Instruments semiconductor products and disclaimers thereto appears at the end of this data sheet.

PowerPAD is a trademark of Texas Instruments.



This integrated circuit can be damaged by ESD. Texas Instruments recommends that all integrated circuits be handled with appropriate precautions. Failure to observe proper handling and installation procedures can cause damage.

ESD damage can range from subtle performance degradation to complete device failure. Precision integrated circuits may be more susceptible to damage because very small parametric changes could cause the device not to meet its published specifications.

**ORDERING INFORMATION<sup>(1)</sup>**

T <sub>A</sub>	SWITCH CURRENT LIMIT	PACKAGE TYPE	SYMBOL	PART NUMBER <sup>(2)</sup>
-40°C to 85°C	1000 mA	SON-10	NUB	TPS63700DRC

- (1) For the most current package and ordering information, see the Package Option Addendum at the end of this document, or see the TI Web site at [www.ti.com](http://www.ti.com).
- (2) The DRC package is available taped and reeled. Add an R suffix to the device type (i.e., TPS63700DRCR) to order quantities of 3000 devices per reel. Add a T suffix to the device type (i.e., TPS63700DRCT) to order quantities of 250 devices per reel.

**ABSOLUTE MAXIMUM RATINGS**

over operating free-air temperature range unless otherwise noted<sup>(1)</sup>

	TPS63700
Input voltage range at V <sub>IN</sub> <sup>(2)</sup>	-0.3 V to +6.0 V
Input voltage range at I <sub>N</sub> <sup>(2)</sup>	V <sub>IN</sub>
Minimum voltage at V <sub>OUT</sub> <sup>(2)</sup>	-18 V
Voltage at EN, FB, COMP, PS <sup>(2)</sup>	-0.3 V to V <sub>IN</sub> + 0.3 V
Differential voltage between OUT to V <sub>IN</sub> <sup>(2)</sup>	24 V
Operating virtual junction temperature, T <sub>J</sub>	-40°C to 150°C
Storage temperature range, T <sub>STG</sub>	-65°C to 150°C

- (1) Stresses beyond those listed under "absolute maximum ratings" may cause permanent damage to the device. These are stress ratings only, and functional operation of the device at these or any other conditions beyond those indicated under "recommended operating conditions" is not implied. Exposure to absolute-maximum-rated conditions for extended periods may affect device reliability.
- (2) All voltage values are with respect to network ground terminal, unless otherwise noted.

**THERMAL INFORMATION**

THERMAL METRIC <sup>(1)</sup>		TPS63700	UNITS
		DRC 10 PINS	
θ <sub>JA</sub>	Junction-to-ambient thermal resistance	41.2	°C/W
θ <sub>JC(TOP)</sub>	Junction-to-case(top) thermal resistance	62.8	
θ <sub>JB</sub>	Junction-to-board thermal resistance	16.6	
ψ <sub>JT</sub>	Junction-to-top characterization parameter	1.2	
ψ <sub>JB</sub>	Junction-to-board characterization parameter	16.8	
θ <sub>JC(BOTTOM)</sub>	Junction-to-case(bottom) thermal resistance	4.1	

- (1) For more information about traditional and new thermal metrics, see the *IC Package Thermal Metrics* application report, [SPRA953](http://SPRA953).

**RECOMMENDED OPERATING CONDITIONS**

	MIN	NOM	MAX	UNIT
Input voltage range, V <sub>I</sub>	2.7		5.5	V
Operating free-air temperature range, T <sub>A</sub>	-40		85	°C
Operating virtual junction temperature range, T <sub>J</sub>	-40		125	°C

**ELECTRICAL CHARACTERISTICS**

–40°C to 85°C, over recommended input voltage range, typical at an ambient temperature of 25°C (unless otherwise noted)

PARAMETER		TEST CONDITIONS	MIN	TYP	MAX	UNIT
<b>DC-DC STAGE</b>						
V <sub>OUT</sub>	Adjustable output voltage range		–15		–2	V
V <sub>IN</sub>	Input voltage range	PIN VIN, IN	2.7		5.5	V
V <sub>REF</sub>	Reference voltage	I <sub>REF</sub> = 10 μA	1.2	1.213	1.225	V
I <sub>FBN</sub>	Negative feedback input bias current	V <sub>FBN</sub> = 0.1 V <sub>REF</sub>		2		nA
V <sub>FBN</sub>	Negative feedback regulation voltage	V <sub>IN</sub> = 2.7 V to 5.5 V	–0.024	0	0.024	V
V <sub>OUT</sub>	DC output accuracy	PWM mode, device switching,		±3		%
V <sub>OVLP</sub>	Output overvoltage protection			–19		V
R <sub>DS(ON)</sub>	Inverter switch on-resistance	V <sub>IN</sub> = 3.6 V		440	600	mΩ
		V <sub>IN</sub> = 5 V		370	500	
I <sub>LIM</sub>	Inverter switch current limit	2.7 V < V <sub>IN</sub> < 5.5 V	860	1000	1140	mA
D <sub>MAX</sub>	Maximum duty cycle inverting converter			87.5%		
D <sub>MIN</sub>	Minimum duty cycle inverting converter			12.5%		
<b>CONTROL STAGE</b>						
f <sub>S</sub>	Oscillator frequency		1250	1380	1500	kHz
V <sub>EN</sub>	High level input voltage		1.4			V
V <sub>EN</sub>	Low level input voltage				0.4	V
I <sub>EN</sub>	Input current	EN = V <sub>IN</sub> or GND		0.01	0.1	μA
I <sub>(Q)</sub>	Quiescent current	V <sub>IN</sub>	V <sub>IN</sub> = 3.6 V, I <sub>OUT</sub> = 0, EN = V <sub>IN</sub> , no switching V <sub>OUT</sub> = –5 V	330	400	μA
		IN		640	750	μA
I <sub>SD</sub>	Shutdown supply current	EN = GND		0.2	1.5	μA
UVLO	Undervoltage lockout threshold		2.1	2.35	2.7	V
	Thermal shutdown			150		°C
	Thermal shutdown hysteresis	Junction temperature decreasing		5		°C

## PIN ASSIGNMENTS

DRC PACKAGE PowerPAD™  
(TOP VIEW)

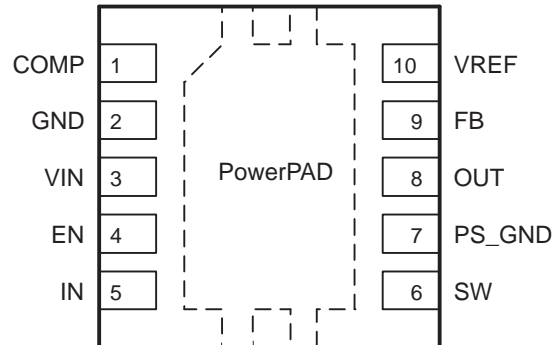

### Terminal Functions

TERMINAL NAME	NO.	I/O	DESCRIPTION
COMP	1	I/O	Compensation pin for control, connect a 4.7nF capacitor between this pin and GND
EN	4	I	Enable pin (EN=GND: disabled; EN=VIN: enabled)
FB	9	I	Feedback pin for the voltage divider
GND	2		Ground pin
IN	5	I	supply voltage for the power switch
OUT	8	I	Output voltage sense input
PS_GND	7	I	Connect to GND for control logic
SW	6	O	Inverter switch output
VIN	3	I	supply voltage input for control logic, connect a RC circuit of 10R and 100nF to filter this supply voltage
VREF	10	O	Reference voltage output. Connect a 220-nF capacitor to ground. Connect the lower resistor of the negative output voltage divider to this pin.



TYPICAL CHARACTERISTICS

PARAMETER MEASUREMENT INFORMATION

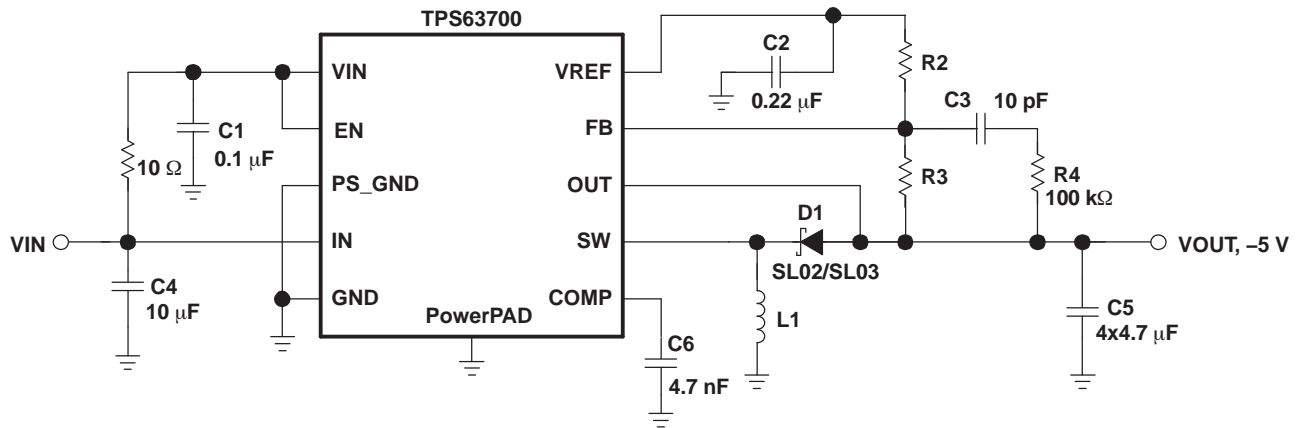

Table 1. List of Components

REFERENCE	DESCRIPTION
C1, C2, C3, C4,	X7R/X5R ceramic
C5	4 x 4.7 μF X7R/X5R ceramic
D1	SL03/SL02 Vishay
L1	-5V: TDK VLF4012 4R7, TDK SLF6025-4R7, Coilcraft LPS4018-472, -12V: Sumida CDRH5D18 10 μH

**Table 2. Table of Graphs**

GRAPH	DESCRIPTION
<a href="#">Figure 2</a>	Maximum output current versus input voltage, $V_{OUT} = -5\text{ V}, -12\text{ V}, -15\text{ V}$
<a href="#">Figure 3</a>	Efficiency versus output current, $V_{OUT} = -5\text{ V}$
<a href="#">Figure 4</a>	Efficiency versus output current, $V_{OUT} = -12\text{ V}$
<a href="#">Figure 5</a>	Efficiency versus output current, $V_{OUT} = -15\text{ V}$
<a href="#">Figure 6</a>	Efficiency versus input voltage, $V_{OUT} = -5\text{ V}$
<a href="#">Figure 7</a>	Efficiency versus input voltage, $V_{OUT} = -12\text{ V}$
<a href="#">Figure 8</a>	Output voltage versus output current, $V_{OUT} = -5\text{ V}$
<a href="#">Figure 9</a>	Output voltage versus output current, $V_{OUT} = -12\text{ V}$
<a href="#">Figure 10</a>	Output voltage in discontinuous conduction mode, $V_{IN} = 3.6\text{ V}, V_{OUT} = -5\text{ V}$
<a href="#">Figure 11</a>	Output voltage in continuous conduction mode, $V_{IN} = 3.6\text{ V}, V_{OUT} = -5\text{ V}$
<a href="#">Figure 12</a>	Load transient response, $V_{IN} = 3.6\text{ V}, V_{OUT} = -5\text{ V}, 45\text{ to }150\text{ mA}$
<a href="#">Figure 13</a>	Line transient response, $V_{IN} = 3.6\text{ V to }4.2\text{ V}, V_{OUT} = -5\text{ V}$
<a href="#">Figure 14</a>	Start-up after enable, $V_I = 3.6\text{ V}, V_{OUT} = -5\text{ V}$

**PERFORMANCE GRAPHS**

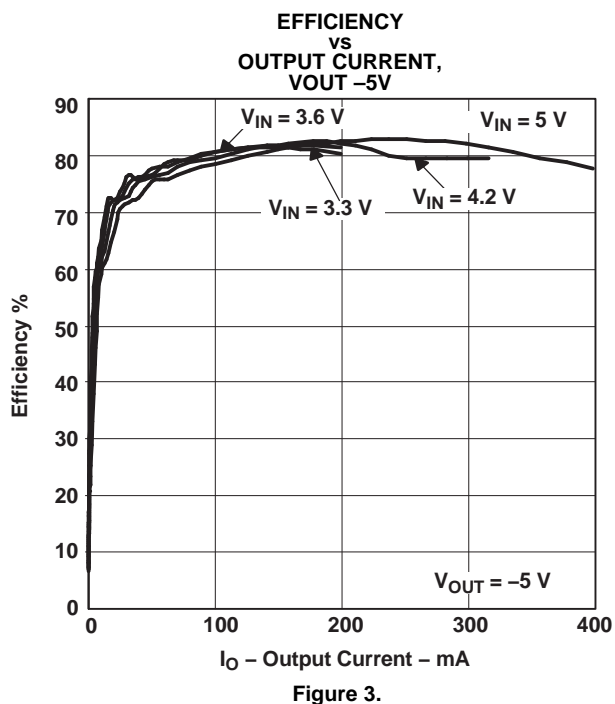
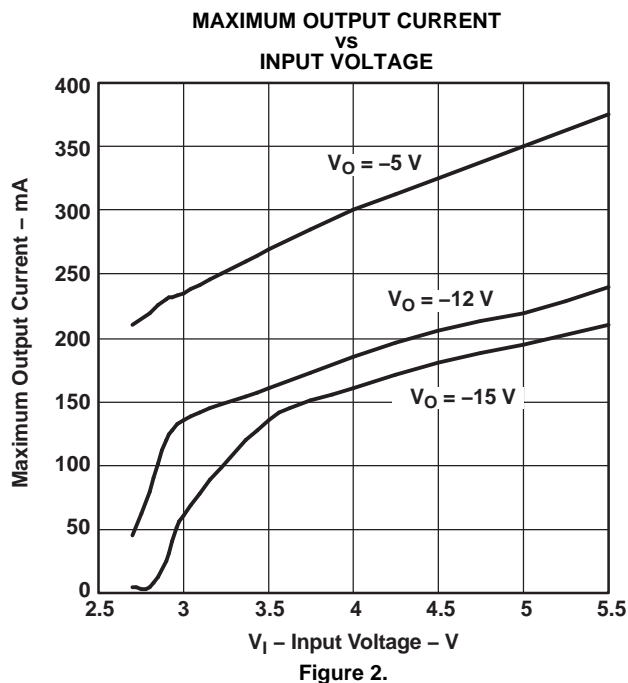

PERFORMANCE GRAPHS (continued)

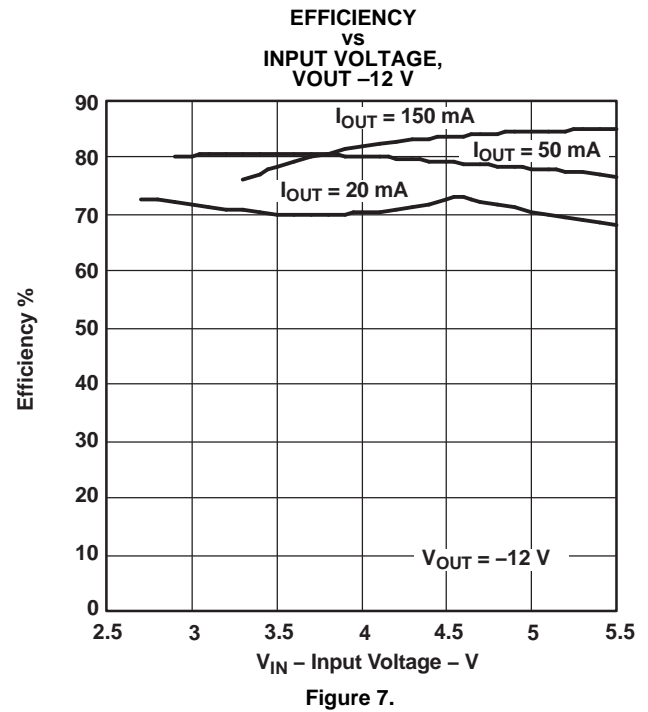
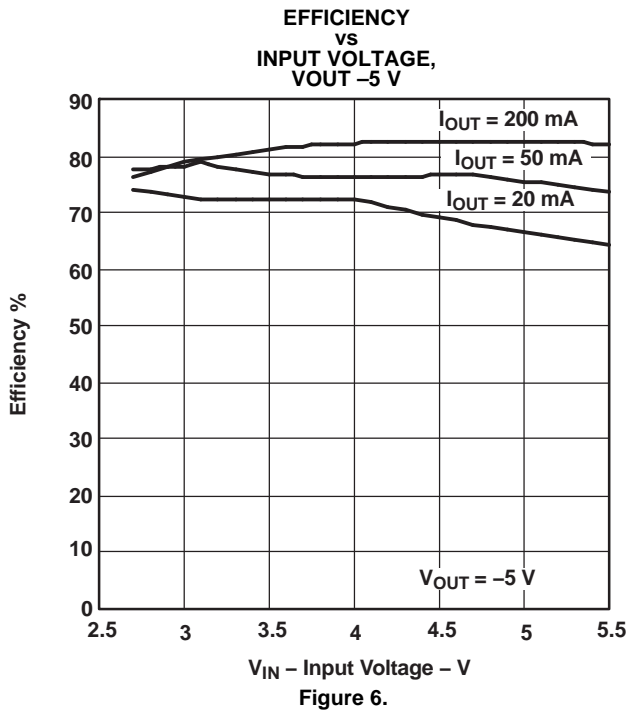
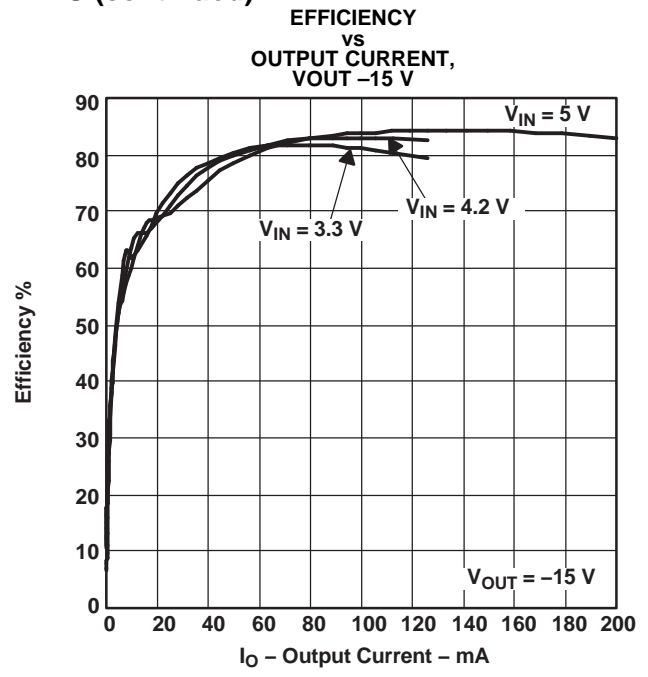
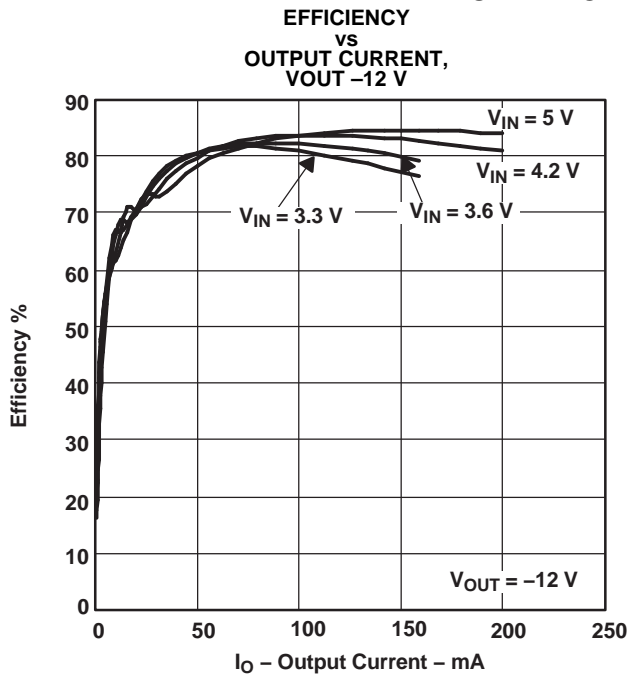

PERFORMANCE GRAPHS (continued)

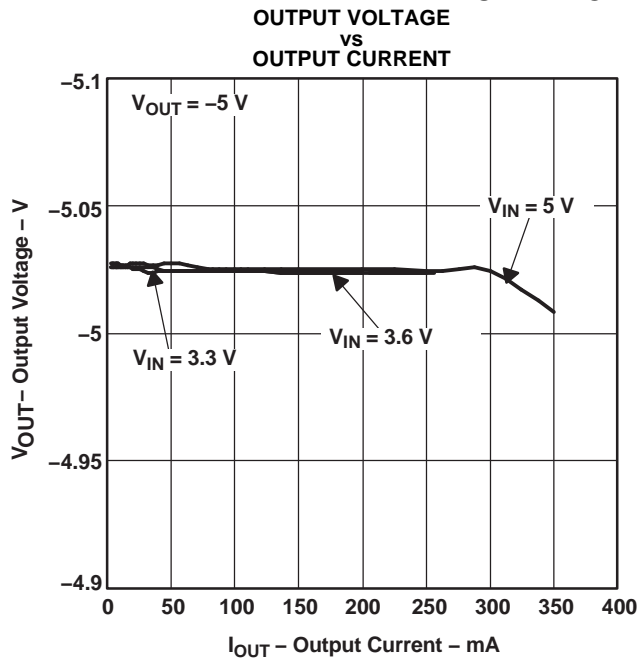

Figure 8.

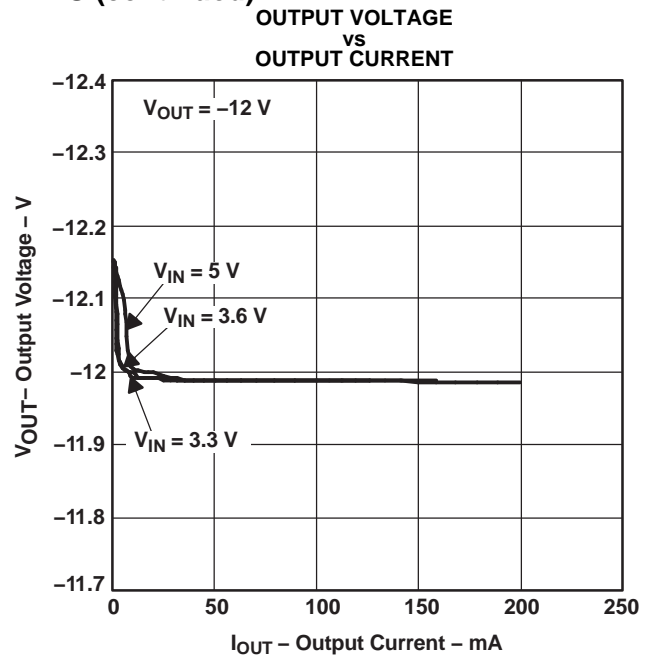

Figure 9.

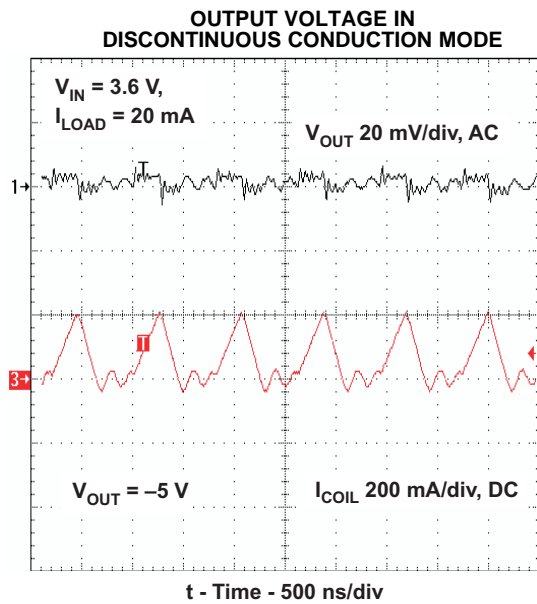

Figure 10.

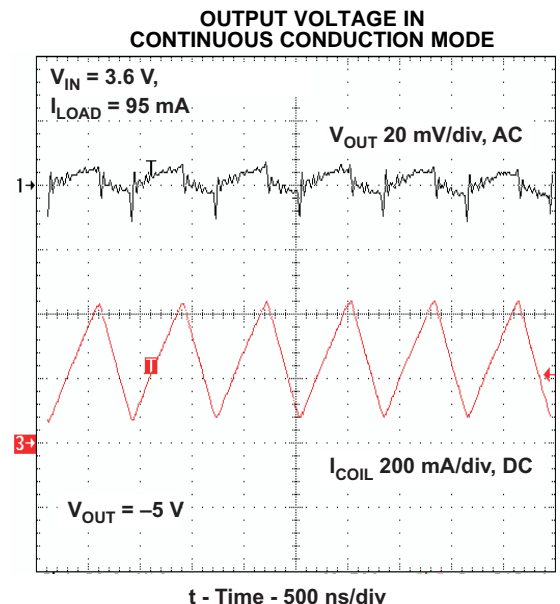

Figure 11.

PERFORMANCE GRAPHS (continued)

LOAD TRANSIENT RESPONSE, -5 V, 45 TO 150 mA

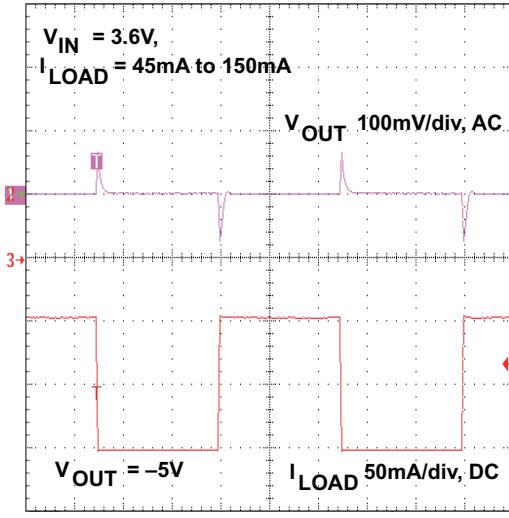

Figure 12.

LINE TRANSIENT RESPONSE, -5 V

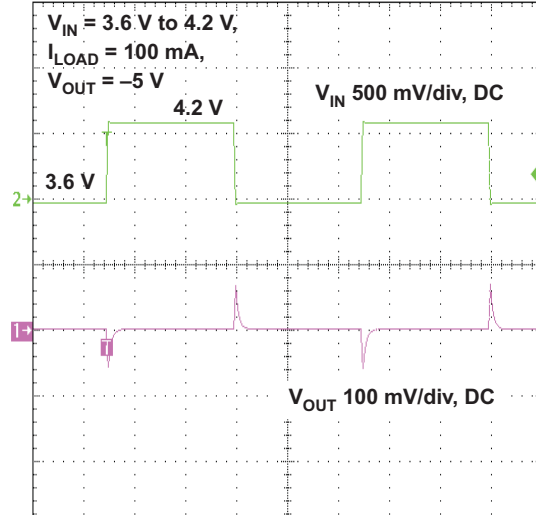

Figure 13.

START-UP AFTER ENABLE, -5 V

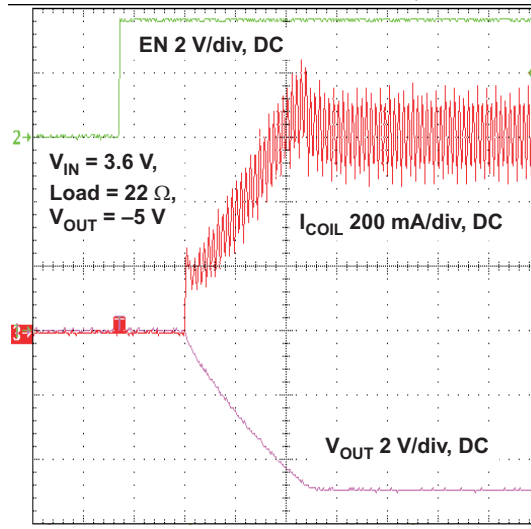

Figure 14.

## DETAILED DESCRIPTION

The TPS63700 is a dc-dc converter for negative output voltages using buck-boost topology. It operates with an input voltage range of 2.7 V to 5.5 V and generates a negative output voltage down to –15 V. The output is controlled by a fixed-frequency, pulse-width-modulated (PWM) regulator. In normal operation mode, the converter operates at continuous conduction mode (CCM). At light loads it can enter discontinuous conduction mode (DCM).

### Power Conversion

The converter operates in a fixed-frequency, pulse-width-modulated control scheme. So, the on-time of the switches varies depending on input-to-output voltage ratio and the load. During this on-time, the inductor connected to the converter is charged with current. In the remaining time, the time period set by the fixed operating frequency, the inductor discharges into the output capacitor via the rectifier diode. Usually, at higher loads the inductor current is continuous. During light load, the inductor current of this converter can become discontinuous. In this case, the control circuit of the controller output automatically takes care of these changing conditions to always operate with an optimum control setup.

### Control

The controller circuit of the converter is based on a fixed-frequency, multiple-feed-forward controller topology. Input voltage, output voltage, and voltage drop across the switch are monitored and forwarded to the regulator. Changes in the operating conditions of the converter directly affect the duty cycle.

The error amplifier compares the voltage on FB pin with GND to generate an accurate and stable output voltage. The error amplifier is internally compensated. At light loads, the converter operates in discontinuous conduction mode (DCM).

If the load will be further decreased, the energy transmitted to the output capacitor can't be absorbed by the load and would lead to an increase of the output voltage. In this case, the converter limits the output voltage increase by skipping switch pulses.

### Enable

Applying GND signal at the EN pin disables the converter, where all internal circuitry is turned off. The device now just consumes low shutdown current flowing into the VIN pin. The output load of the converter is also disconnected from the battery as described in the following paragraph. Pulling the EN pin to  $V_{IN}$  enables the converter. Internal circuitry, necessary to operate the converter, is then turned on.

### Load Disconnect

The device supports complete load disconnection when the converter is disabled. The converter turns off the internal PMOS switch, thus no DC current path remains between load and input voltage source.

### Soft Start

The converter has a soft-start function. When the converter is enabled, the implemented switch current limit ramps up slowly to its nominal value. Soft start is implemented to limit the input current during start-up to avoid high peak currents at the battery which could interfere with other systems connected to the same battery.

Without soft start, uncontrolled input peak currents flow to charge up the output capacitors and to supply the load during start-up. This would cause significant voltage drops across the series resistance of the battery and its connections.

### Output Overvoltage Protection

The converter has an implemented output overvoltage protection. The output voltage is limited to –19 V in case the feedback connection from the output to the FB pin is open.

## Undervoltage Lockout

An undervoltage lockout prevents the device from starting up and operating if the supply voltage at VIN is lower than the programmed threshold shown in the electrical characteristics table. The device automatically shuts down the converter when the supply voltage at VIN falls below this threshold. Nevertheless, parts of the control circuits remain active, which is different than device shutdown using EN inputs. The undervoltage lockout function is implemented to prevent device malfunction.

## Overtemperature Shutdown

The device automatically shuts down if the implemented internal temperature detector detects a chip temperature above the programmed threshold shown in the electrical characteristics table. It starts operating again when the chip temperature decreases. A built-in temperature hysteresis avoids undefined operation caused by ringing from overtemperature shutdown.

## APPLICATION INFORMATION

### Design Procedure

The TPS63700 dc-dc converter is intended for systems typically powered by a single-cell Li-ion or Li-polymer battery with a terminal voltage between 2.7 V up to 4.2 V. Due to the recommended input voltage going up to 5.5 V, the device is also suitable for 3-cell alkaline, NiCd, or NiMH batteries, as well as regulated supply voltages of 3.3 V or 5 V.

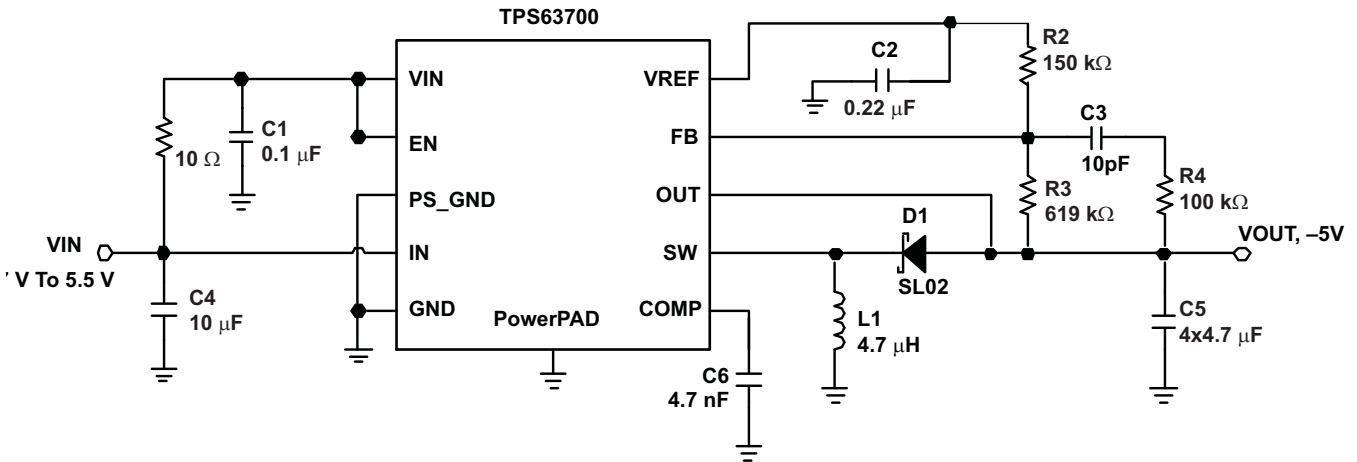

Figure 15. Circuit for –5 Volt Output

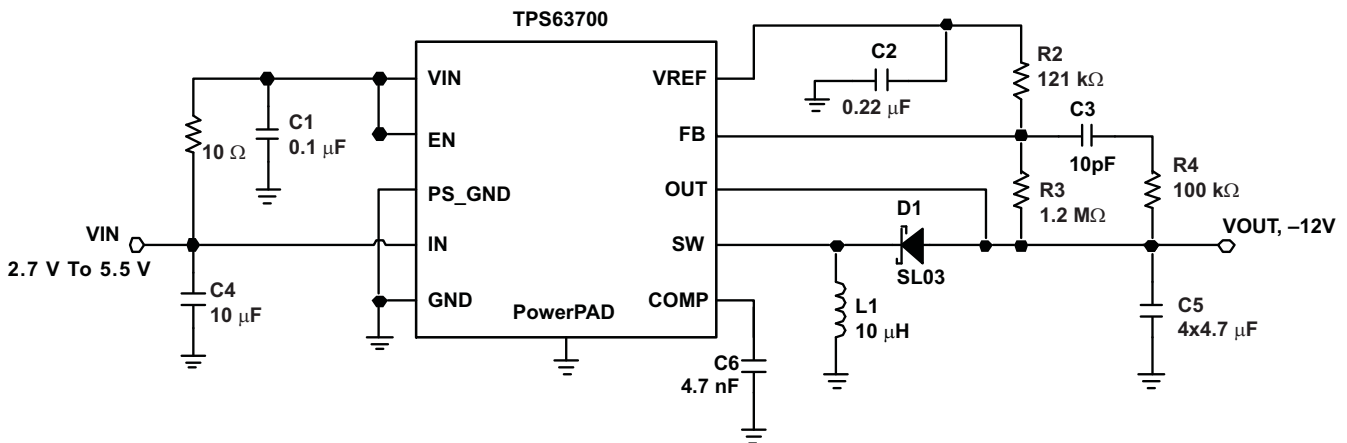

Figure 16. Circuit for –12 Volt Output

### Programming the Output Voltage

#### Converter

The output voltage of the TPS63700 converter can be adjusted with an external resistor divider connected to the FB pin. The reference point of the feedback divider is the reference voltage VREF with 1.213 V. The typical value of the voltage at the FB pin is 0 V. The minimum recommended output voltage at the converter is –15 V. The feedback divider current should be 10  $\mu$ A. The voltage across R2 is 1.213 V. Based on those values, the recommended value for R2 should be 120 k $\Omega$  to 200 k $\Omega$  in order to set the divider current at the required value. The value of the resistor R3 can then be calculated using Equation 1, depending on the needed output voltage (V<sub>OUT</sub>):

$$R3 = R2 \times \left( \frac{V_{REF} - V_{OUT}}{V_{REF}} - 1 \right) \quad (1)$$

For example, if an output voltage of  $-5\text{ V}$  is needed and a resistor of  $150\text{ k}\Omega$  has been chosen for  $R_2$ , a  $619\text{-k}\Omega$  resistor is needed to program the desired output voltage.

### Inductor Selection

An inductive converter normally requires two main passive components for storing energy during the conversion. An inductor and a storage capacitor at the output are required.

The average inductor current depends on the output load, the input voltage ( $V_{IN}$ ), and the output voltage  $V_{OUT}$ . It can be estimated with [Equation 2](#), which shows the formula for the inverting converter.

$$I_{Lavg} = \frac{V_{IN} - V_{OUT}}{V_{IN} \times 0.8} \times I_{OUT} \quad (2)$$

with:

$I_{Lavg}$  = average inductor current

An important parameter for choosing the inductor is the desired current ripple in the inductor.

A ripple current value between 20% and 80% of the average inductor current can be considered as reasonable, depending on the application requirements. A smaller ripple reduces the losses in the inductor, as well as output voltage ripple and EMI. But in the same way, the inductor becomes larger and more expensive.

Keeping those parameters in mind, the possible inductor value can be calculated using [Equation 3](#).

$$L = \frac{V_{IN} \times V_{OUT}}{\Delta I_L \times (V_{OUT} - V_{IN}) \times f} \quad (3)$$

with:

$\Delta I_L$  = peak-to-peak ripple current

$f$  = switching frequency

$L$  = inductor value

With the known inductor current ripple, the peak inductor value can be approximated with [Equation 4](#). The peak current through the switch and the inductor depends also on the output load, the input voltage ( $V_{IN}$ ), and the output voltage ( $V_{OUT}$ ). To select the right inductor, it is recommended to keep the possible peak inductor current below the current-limit threshold of the power switch. For example, the current-limit threshold of the TPS63700 switch for the inverting converter is nominally  $1000\text{ mA}$ .

$$I_{Lmax} = \frac{V_{IN} - V_{OUT}}{V_{IN} \times 0.8} \times I_{OUT} + \frac{\Delta I_L}{2} \quad (4)$$

with:

$I_{LMAX}$  = peak inductor current

With [Equation 5](#), the inductor current ripple at a given inductor can be approximated.

$$\Delta I_L = \frac{V_{IN} \times V_{OUT}}{L \times (V_{OUT} - V_{IN}) \times f} \quad (5)$$

Care has to be taken for the possibility that load transients and losses in the circuit can lead to higher currents as estimated in [Equation 4](#). Also, the losses caused by magnetic hysteresis losses and copper losses are a major parameter for total circuit efficiency.

The following inductor series from different suppliers have been tested with the TPS63700 converter:

**Table 3. List of Inductors**

Output Voltage	Vendor	SUGGESTED INDUCTOR
-5V	TDK	VLF4012 4.7 $\mu$ H
		SLF6025-4.7 $\mu$ H
-5V	Coilcraft	LPS4018 4.7 $\mu$ H
		LPS3015 4.7 $\mu$ H
-12V	Sumida	CDRH5D18 10 $\mu$ H
-12V	Coilcraft	MOS6020 10 $\mu$ H

## Capacitor Selection

### Input Capacitor

At least a 10- $\mu$ F ceramic input capacitor is recommended for a good transient behavior of the regulator, and EMI behavior of the total power supply circuit.

### Output Capacitors

One of the major parameters necessary to define the capacitance value of the output capacitor is the maximum allowed output voltage ripple of the converter. This ripple is determined by two parameters of the capacitor, the capacitance and the ESR. It is possible to calculate the minimum capacitance needed for the defined ripple, supposing that the ESR is zero, by using [Equation 6](#) for the inverting converter output capacitor.

$$C_{\min} = \frac{I_{\text{OUT}} \times V_{\text{OUT}}}{f_{\text{S}} \times \Delta V \times (V_{\text{OUT}} - V_{\text{IN}})} \quad (6)$$

Parameter  $f$  is the switching frequency and  $\Delta V$  is the maximum allowed ripple.

With a chosen ripple voltage in the range of 10 mV, a minimum capacitance of 12  $\mu$ F is needed. The total ripple is larger due to the ESR of the output capacitor. This additional component of the ripple can be calculated using [Equation 7](#).

$$\Delta V_{\text{ESR}} = I_{\text{OUT}} \times R_{\text{ESR}} \quad (7)$$

An additional ripple of 2 mV is the result of using a typical ceramic capacitor with an ESR in a 10-m $\Omega$  range. The total ripple is the sum of the ripple caused by the capacitance, and the ripple caused by the ESR of the capacitor. In this example, the total ripple is 12 mV. Additional ripple is caused by load transients. When the load current increases rapidly, the output capacitor must provide the additional current until the inductor current has been increased by the control loop by setting a higher on-time at the main switch (duty cycle). The higher duty cycle results in longer inductor charging periods. But the rate of increase of the inductor current is also limited by the inductance itself. When the load current decreases rapidly, the output capacitor needs to store the excessive energy (stored in the inductor) until the regulator has decreased the inductor current by reducing the duty cycle. The recommendation is to use higher capacitance values, as the previous calculations show.

## Stabilizing the Control Loop

### Feedback Divider

To speed up the control loop, a feed-forward capacitor of 10 pF is recommended in the feedback divider, parallel to R3.

To avoid coupling noise into the control loop from the feed-forward capacitor, the feed-forward effect can be bandwidth-limited by adding series resistor R4. A value in the range of 100 k $\Omega$  is suitable. The higher the resistance, the lower the noise coupled into the control loop system.

**Compensation Capacitor**

The control loop of the converter is completely compensated internally. However the internal feed-forward system requires an external capacitor. A 4.7-nF capacitor at the COMP pin of the converter is recommended.

**Layout Considerations**

For all switching power supplies the layout is an important step in the design, especially at high peak currents and high switching frequencies. If the layout is not carefully done, the regulator could show stability problems as well as EMI problems. Therefore, use wide and short traces for the main current paths, and for the power-ground tracks. The input and output capacitors should be placed as close as possible to the IC. The diode need to be connected closest to the SW PIN to minimize parasitic inductance. For low noise operation small bypass capacitors  $C_{IN\ BP}$  and  $C_{OUT\ BP}$  in the nF range can be added close to the IC.

The feedback divider should be placed as close as possible to the VREF pin of the IC. Use short traces when laying out the control ground. Figure 19 shows the layout of the EVM board.

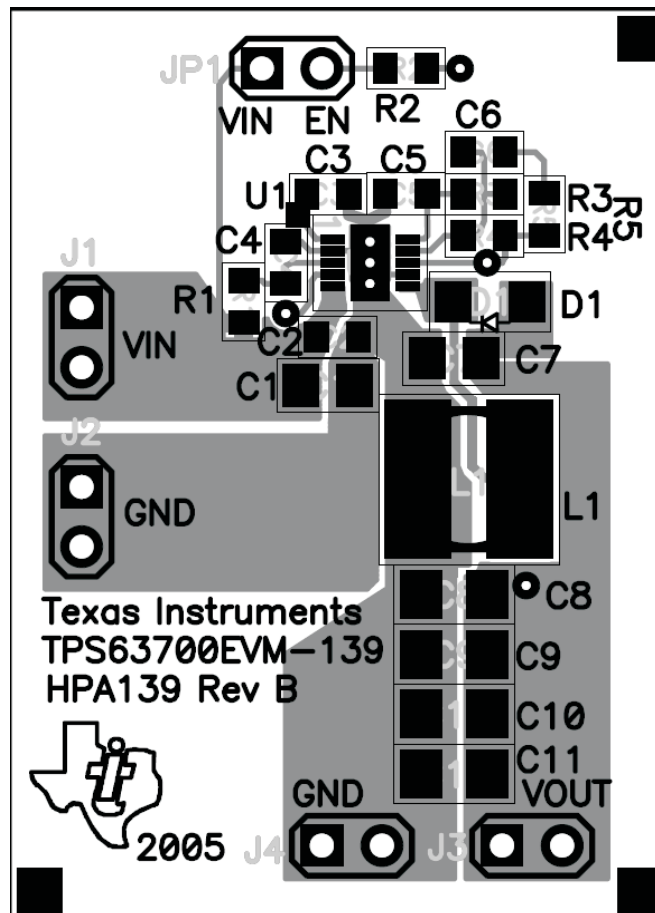

Figure 17. Layout Considerations, Top View

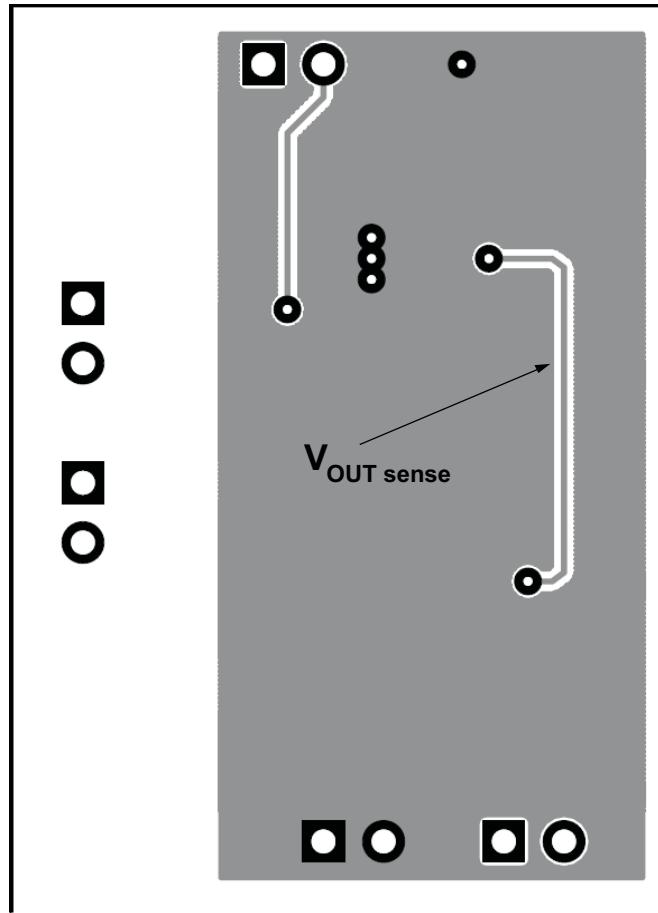

Figure 18. Layout Considerations, Bottom View

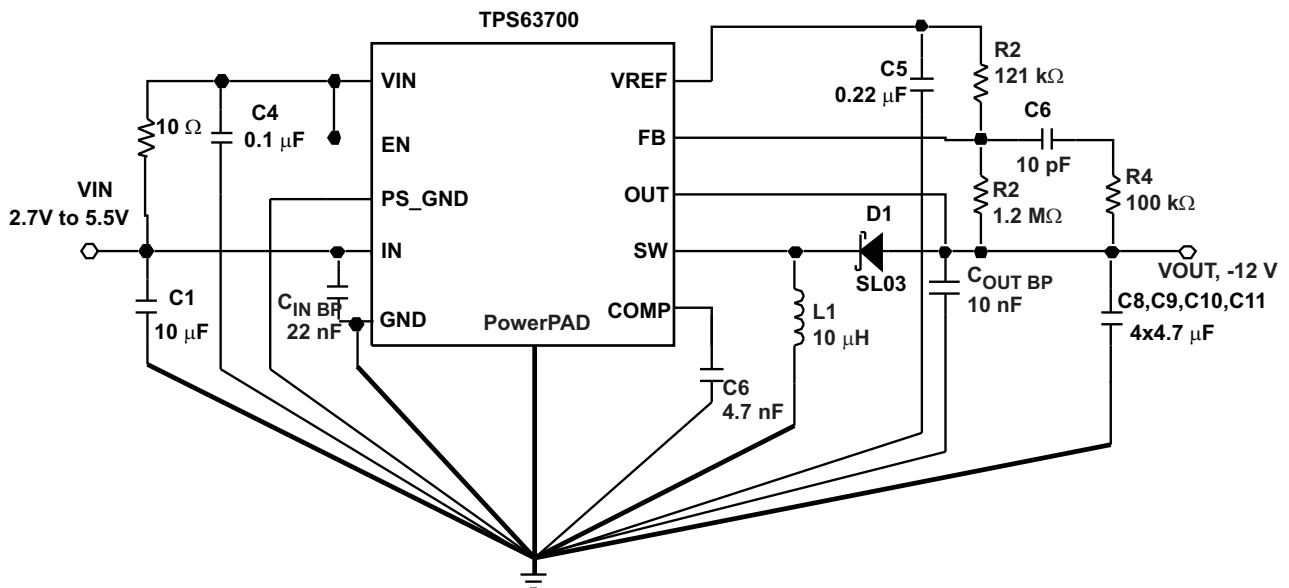

Figure 19. Layout Circuit

## THERMAL INFORMATION

Implementation of integrated circuits in low-profile and fine-pitch surface-mount packages typically requires special attention to power dissipation. Many system-dependent issues, such as thermal coupling, airflow, added heatsinks and convection surfaces, and the presence of heat-generating components affect the power-dissipation limits of a given component.

Three basic approaches for enhancing thermal performance are:

- Improving the power dissipation capability of the PCB design
- Improving the thermal coupling of the component to the PCB
- Introducing airflow to the system

The maximum recommended junction temperature ( $T_J$ ) of the TPS63700 device is 125°C. The thermal resistance of the 10-pin SON, 3 × 3-mm package (DRC) is  $R_{JA} = 48.7^\circ\text{C}/\text{W}$ . Specified regulator operation is ensured to a maximum ambient temperature  $T_A$  of 85°C. Therefore, the maximum power dissipation is about 821 mW. More power can be dissipated if the maximum ambient temperature of the application is lower.

$$P_{\text{DMAX}} = \frac{T_{\text{JMAX}} - T_A}{R_{\theta\text{JA}}} \quad (8)$$

---

<b>Changes from Revision B (November 2007) to Revision C</b>	<b>Page</b>
• Deleted Dissipation Ratings table and added Thermal Information table. ....	<a href="#">2</a>

---

**PACKAGING INFORMATION**

Orderable Device	Status (1)	Package Type	Package Drawing	Pins	Package Qty	Eco Plan (2)	Lead/Ball Finish (6)	MSL Peak Temp (3)	Op Temp (°C)	Device Marking (4/5)	Samples
TPS63700DRCCR	ACTIVE	SON	DRC	10	3000	Green (RoHS & no Sb/Br)	CU NIPDAU	Level-2-260C-1 YEAR	-40 to 85	NUB	<a href="#">Samples</a>
TPS63700DRCRG4	ACTIVE	SON	DRC	10	3000	Green (RoHS & no Sb/Br)	CU NIPDAU	Level-2-260C-1 YEAR	-40 to 85	NUB	<a href="#">Samples</a>
TPS63700DRCT	ACTIVE	SON	DRC	10	250	Green (RoHS & no Sb/Br)	CU NIPDAU	Level-2-260C-1 YEAR	-40 to 85	NUB	<a href="#">Samples</a>
TPS63700DRCTG4	ACTIVE	SON	DRC	10	250	Green (RoHS & no Sb/Br)	CU NIPDAU	Level-2-260C-1 YEAR	-40 to 85	NUB	<a href="#">Samples</a>

(1) The marketing status values are defined as follows:

**ACTIVE:** Product device recommended for new designs.

**LIFEBUY:** TI has announced that the device will be discontinued, and a lifetime-buy period is in effect.

**NRND:** Not recommended for new designs. Device is in production to support existing customers, but TI does not recommend using this part in a new design.

**PREVIEW:** Device has been announced but is not in production. Samples may or may not be available.

**OBSOLETE:** TI has discontinued the production of the device.

(2) Eco Plan - The planned eco-friendly classification: Pb-Free (RoHS), Pb-Free (RoHS Exempt), or Green (RoHS & no Sb/Br) - please check <http://www.ti.com/productcontent> for the latest availability information and additional product content details.

**TBD:** The Pb-Free/Green conversion plan has not been defined.

**Pb-Free (RoHS):** TI's terms "Lead-Free" or "Pb-Free" mean semiconductor products that are compatible with the current RoHS requirements for all 6 substances, including the requirement that lead not exceed 0.1% by weight in homogeneous materials. Where designed to be soldered at high temperatures, TI Pb-Free products are suitable for use in specified lead-free processes.

**Pb-Free (RoHS Exempt):** This component has a RoHS exemption for either 1) lead-based flip-chip solder bumps used between the die and package, or 2) lead-based die adhesive used between the die and leadframe. The component is otherwise considered Pb-Free (RoHS compatible) as defined above.

**Green (RoHS & no Sb/Br):** TI defines "Green" to mean Pb-Free (RoHS compatible), and free of Bromine (Br) and Antimony (Sb) based flame retardants (Br or Sb do not exceed 0.1% by weight in homogeneous material)

(3) MSL, Peak Temp. - The Moisture Sensitivity Level rating according to the JEDEC industry standard classifications, and peak solder temperature.

(4) There may be additional marking, which relates to the logo, the lot trace code information, or the environmental category on the device.

(5) Multiple Device Markings will be inside parentheses. Only one Device Marking contained in parentheses and separated by a "~" will appear on a device. If a line is indented then it is a continuation of the previous line and the two combined represent the entire Device Marking for that device.

(6) Lead/Ball Finish - Orderable Devices may have multiple material finish options. Finish options are separated by a vertical ruled line. Lead/Ball Finish values may wrap to two lines if the finish value exceeds the maximum column width.

**Important Information and Disclaimer:** The information provided on this page represents TI's knowledge and belief as of the date that it is provided. TI bases its knowledge and belief on information provided by third parties, and makes no representation or warranty as to the accuracy of such information. Efforts are underway to better integrate information from third parties. TI has taken and continues to take reasonable steps to provide representative and accurate information but may not have conducted destructive testing or chemical analysis on incoming materials and chemicals. TI and TI suppliers consider certain information to be proprietary, and thus CAS numbers and other limited information may not be available for release.

In no event shall TI's liability arising out of such information exceed the total purchase price of the TI part(s) at issue in this document sold by TI to Customer on an annual basis.

**TAPE AND REEL INFORMATION**

**QUADRANT ASSIGNMENTS FOR PIN 1 ORIENTATION IN TAPE**

\*All dimensions are nominal

Device	Package Type	Package Drawing	Pins	SPQ	Reel Diameter (mm)	Reel Width W1 (mm)	A0 (mm)	B0 (mm)	K0 (mm)	P1 (mm)	W (mm)	Pin1 Quadrant
TPS63700DRCR	SON	DRC	10	3000	330.0	12.4	3.3	3.3	1.1	8.0	12.0	Q2
TPS63700DRCT	SON	DRC	10	250	180.0	12.4	3.3	3.3	1.1	8.0	12.0	Q2

**TAPE AND REEL BOX DIMENSIONS**

\*All dimensions are nominal

Device	Package Type	Package Drawing	Pins	SPQ	Length (mm)	Width (mm)	Height (mm)
TPS63700DRCR	SON	DRC	10	3000	367.0	367.0	35.0
TPS63700DRCT	SON	DRC	10	250	210.0	185.0	35.0

DRC (S-PVSON-N10)

PLASTIC SMALL OUTLINE NO-LEAD

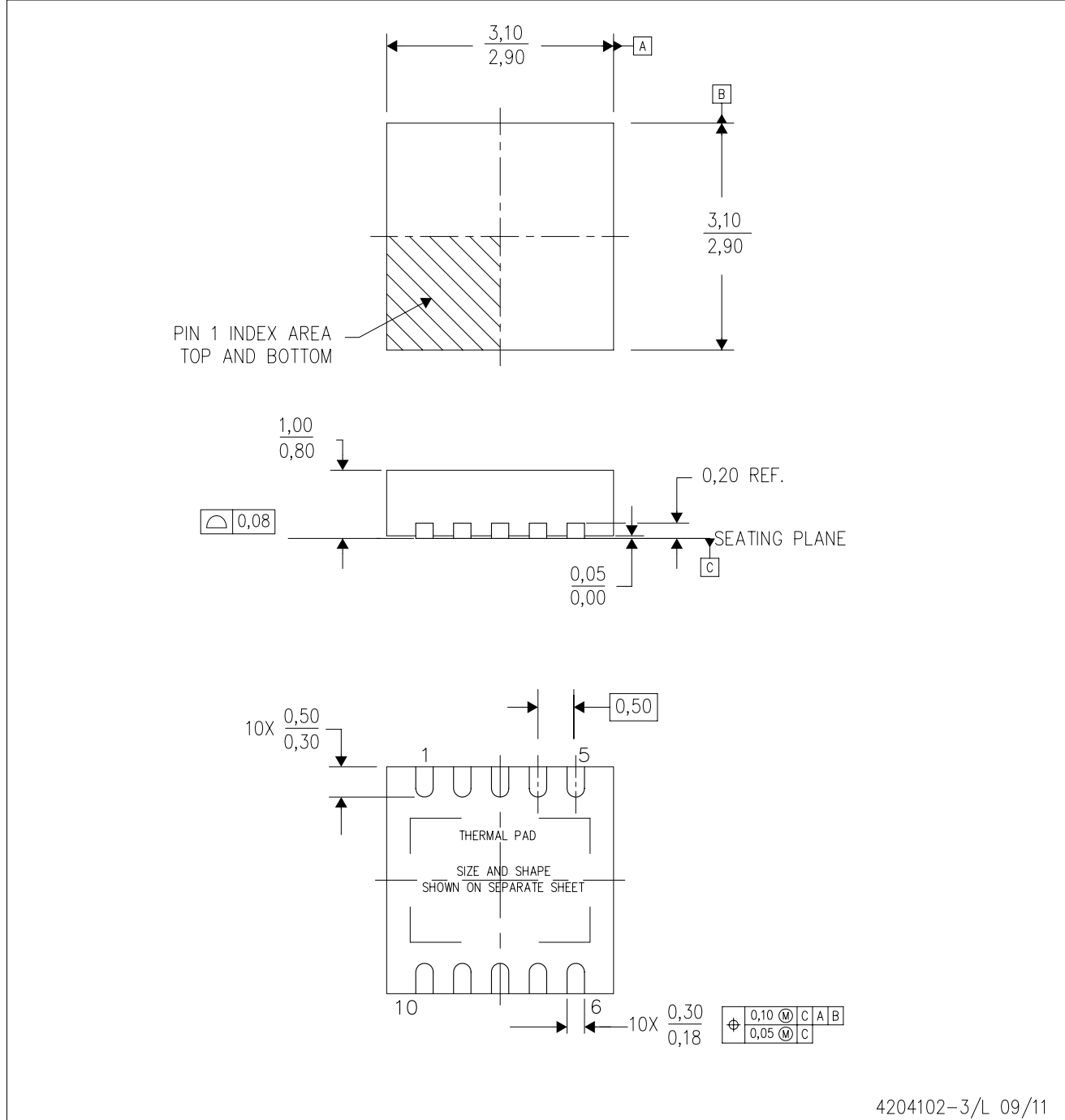

- NOTES:
- All linear dimensions are in millimeters. Dimensioning and tolerancing per ASME Y14.5M-1994.
  - This drawing is subject to change without notice.
  - Small Outline No-Lead (SON) package configuration.
  - The package thermal pad must be soldered to the board for thermal and mechanical performance, if present.
  - See the additional figure in the Product Data Sheet for details regarding the exposed thermal pad features and dimensions, if present

# THERMAL PAD MECHANICAL DATA

DRC (S-PVSON-N10)

PLASTIC SMALL OUTLINE NO-LEAD

## THERMAL INFORMATION

This package incorporates an exposed thermal pad that is designed to be attached directly to an external heatsink. The thermal pad must be soldered directly to the printed circuit board (PCB). After soldering, the PCB can be used as a heatsink. In addition, through the use of thermal vias, the thermal pad can be attached directly to the appropriate copper plane shown in the electrical schematic for the device, or alternatively, can be attached to a special heatsink structure designed into the PCB. This design optimizes the heat transfer from the integrated circuit (IC).

For information on the Quad Flatpack No-Lead (QFN) package and its advantages, refer to Application Report, QFN/SON PCB Attachment, Texas Instruments Literature No. SLUA271. This document is available at [www.ti.com](http://www.ti.com).

The exposed thermal pad dimensions for this package are shown in the following illustration.

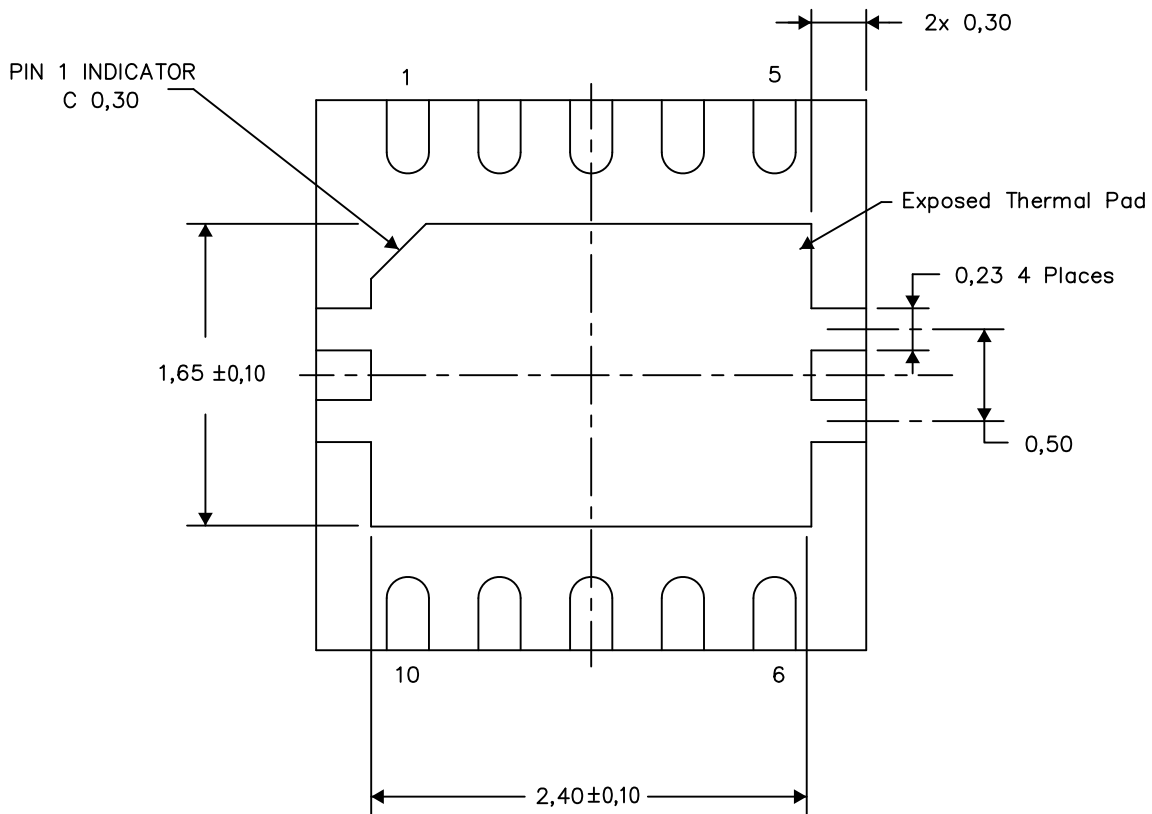

Exposed Thermal Pad Dimensions

4206565-3/U 04/14

NOTE: A. All linear dimensions are in millimeters

DRC (S-PVSON-N10)

PLASTIC SMALL OUTLINE NO-LEAD

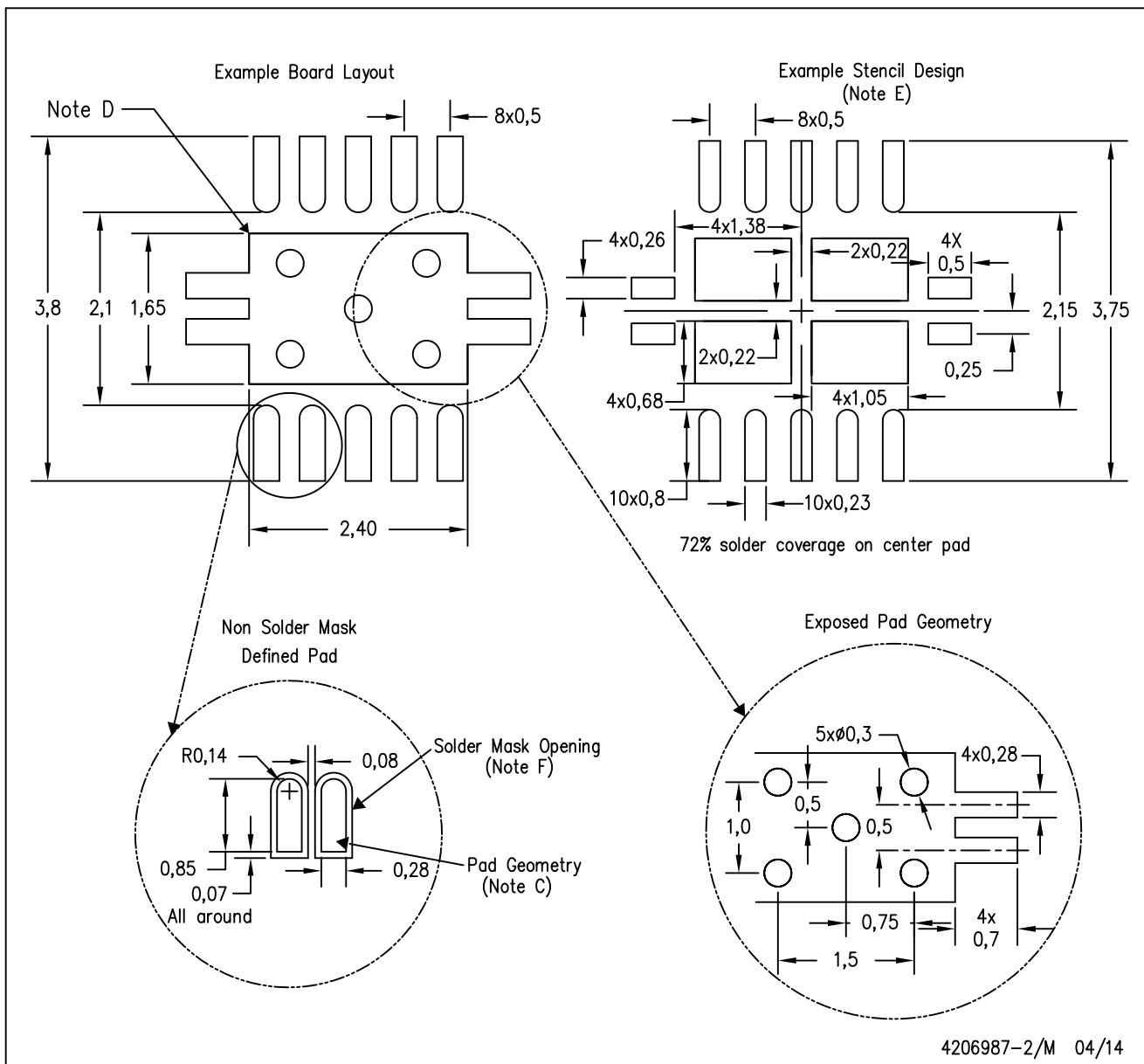

- NOTES:
- All linear dimensions are in millimeters.
  - This drawing is subject to change without notice.
  - Publication IPC-7351 is recommended for alternate designs.
  - This package is designed to be soldered to a thermal pad on the board. Refer to Application Note, Quad Flat-Pack Packages, Texas Instruments Literature No. SLUA271, and also the Product Data Sheets for specific thermal information, via requirements, and recommended board layout. These documents are available at [www.ti.com](http://www.ti.com) <<http://www.ti.com>>.
  - Laser cutting apertures with trapezoidal walls and also rounding corners will offer better paste release. Customers should contact their board assembly site for stencil design recommendations. Refer to IPC 7525 for stencil design considerations.
  - Customers should contact their board fabrication site for minimum solder mask web tolerances between signal pads.

## IMPORTANT NOTICE

Texas Instruments Incorporated and its subsidiaries (TI) reserve the right to make corrections, enhancements, improvements and other changes to its semiconductor products and services per JESD46, latest issue, and to discontinue any product or service per JESD48, latest issue. Buyers should obtain the latest relevant information before placing orders and should verify that such information is current and complete. All semiconductor products (also referred to herein as "components") are sold subject to TI's terms and conditions of sale supplied at the time of order acknowledgment.

TI warrants performance of its components to the specifications applicable at the time of sale, in accordance with the warranty in TI's terms and conditions of sale of semiconductor products. Testing and other quality control techniques are used to the extent TI deems necessary to support this warranty. Except where mandated by applicable law, testing of all parameters of each component is not necessarily performed.

TI assumes no liability for applications assistance or the design of Buyers' products. Buyers are responsible for their products and applications using TI components. To minimize the risks associated with Buyers' products and applications, Buyers should provide adequate design and operating safeguards.

TI does not warrant or represent that any license, either express or implied, is granted under any patent right, copyright, mask work right, or other intellectual property right relating to any combination, machine, or process in which TI components or services are used. Information published by TI regarding third-party products or services does not constitute a license to use such products or services or a warranty or endorsement thereof. Use of such information may require a license from a third party under the patents or other intellectual property of the third party, or a license from TI under the patents or other intellectual property of TI.

Reproduction of significant portions of TI information in TI data books or data sheets is permissible only if reproduction is without alteration and is accompanied by all associated warranties, conditions, limitations, and notices. TI is not responsible or liable for such altered documentation. Information of third parties may be subject to additional restrictions.

Resale of TI components or services with statements different from or beyond the parameters stated by TI for that component or service voids all express and any implied warranties for the associated TI component or service and is an unfair and deceptive business practice. TI is not responsible or liable for any such statements.

Buyer acknowledges and agrees that it is solely responsible for compliance with all legal, regulatory and safety-related requirements concerning its products, and any use of TI components in its applications, notwithstanding any applications-related information or support that may be provided by TI. Buyer represents and agrees that it has all the necessary expertise to create and implement safeguards which anticipate dangerous consequences of failures, monitor failures and their consequences, lessen the likelihood of failures that might cause harm and take appropriate remedial actions. Buyer will fully indemnify TI and its representatives against any damages arising out of the use of any TI components in safety-critical applications.

In some cases, TI components may be promoted specifically to facilitate safety-related applications. With such components, TI's goal is to help enable customers to design and create their own end-product solutions that meet applicable functional safety standards and requirements. Nonetheless, such components are subject to these terms.

No TI components are authorized for use in FDA Class III (or similar life-critical medical equipment) unless authorized officers of the parties have executed a special agreement specifically governing such use.

Only those TI components which TI has specifically designated as military grade or "enhanced plastic" are designed and intended for use in military/aerospace applications or environments. Buyer acknowledges and agrees that any military or aerospace use of TI components which have **not** been so designated is solely at the Buyer's risk, and that Buyer is solely responsible for compliance with all legal and regulatory requirements in connection with such use.

TI has specifically designated certain components as meeting ISO/TS16949 requirements, mainly for automotive use. In any case of use of non-designated products, TI will not be responsible for any failure to meet ISO/TS16949.

### Products

Audio	<a href="http://www.ti.com/audio">www.ti.com/audio</a>
Amplifiers	<a href="http://amplifier.ti.com">amplifier.ti.com</a>
Data Converters	<a href="http://dataconverter.ti.com">dataconverter.ti.com</a>
DLP® Products	<a href="http://www.dlp.com">www.dlp.com</a>
DSP	<a href="http://dsp.ti.com">dsp.ti.com</a>
Clocks and Timers	<a href="http://www.ti.com/clocks">www.ti.com/clocks</a>
Interface	<a href="http://interface.ti.com">interface.ti.com</a>
Logic	<a href="http://logic.ti.com">logic.ti.com</a>
Power Mgmt	<a href="http://power.ti.com">power.ti.com</a>
Microcontrollers	<a href="http://microcontroller.ti.com">microcontroller.ti.com</a>
RFID	<a href="http://www.ti-rfid.com">www.ti-rfid.com</a>
OMAP Applications Processors	<a href="http://www.ti.com/omap">www.ti.com/omap</a>
Wireless Connectivity	<a href="http://www.ti.com/wirelessconnectivity">www.ti.com/wirelessconnectivity</a>

### Applications

Automotive and Transportation	<a href="http://www.ti.com/automotive">www.ti.com/automotive</a>
Communications and Telecom	<a href="http://www.ti.com/communications">www.ti.com/communications</a>
Computers and Peripherals	<a href="http://www.ti.com/computers">www.ti.com/computers</a>
Consumer Electronics	<a href="http://www.ti.com/consumer-apps">www.ti.com/consumer-apps</a>
Energy and Lighting	<a href="http://www.ti.com/energy">www.ti.com/energy</a>
Industrial	<a href="http://www.ti.com/industrial">www.ti.com/industrial</a>
Medical	<a href="http://www.ti.com/medical">www.ti.com/medical</a>
Security	<a href="http://www.ti.com/security">www.ti.com/security</a>
Space, Avionics and Defense	<a href="http://www.ti.com/space-avionics-defense">www.ti.com/space-avionics-defense</a>
Video and Imaging	<a href="http://www.ti.com/video">www.ti.com/video</a>

### TI E2E Community

[e2e.ti.com](http://e2e.ti.com)