



17-V, 1.5-A, SYNCHRONOUS STEP-DOWN CONVERTER

 Check for Samples: [TPS62110](#), [TPS62111](#), [TPS62112](#), [TPS62113](#)

FEATURES

- High-Efficiency Synchronous Step-Down Converter With up to 95% Efficiency
- 3.1-V to 17-V Operating Input Voltage Range
- Adjustable Output Voltage Range From 1.2 V to 16 V
- Fixed Output Voltage Options Available in 3.3 V and 5 V
- Synchronizable to External Clock Signal up to 1.4 MHz
- Up to 1.5-A Output Current
- High Efficiency Over a Wide Load-Current Range Due to PFM/PWM Operation Mode
- 100% Maximum Duty Cycle for Lowest Dropout
- 20- μ A Quiescent Current (Typical)
- Overtemperature and Overcurrent Protected
- Available in 16-Pin QFN Package

APPLICATIONS

- Point-of-Load Regulation From 12-V Bus
- Organizers, PDAs, and Handheld PCs
- Handheld Scanners

TYPICAL APPLICATION

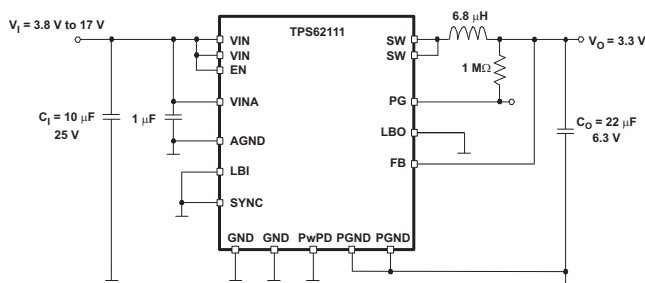

DESCRIPTION

The TPS6211x devices are a family of low-noise synchronous step-down dc-dc converters that are ideally suited for systems powered from a 2 to 4-cell Li-ion battery or from a 12-V or 15-V rail.

The TPS6211x is a synchronous PWM converter with integrated N- and P-channel power MOSFET switches. Synchronous rectification is used to increase efficiency and to reduce external component count. To achieve highest efficiency over a wide load-current range, the converter enters a power-saving, pulse-frequency modulation (PFM) mode at light load currents. Operating frequency is typically 1 MHz, allowing the use of small inductor and capacitor values. The device can be synchronized to an external clock signal in the range of 0.8 MHz to 1.4 MHz. For low-noise operation, the converter can be operated in PWM-only mode. In the shutdown mode, the current consumption is reduced to less than 2 μ A. The TPS6211x is available in the 16-pin (RSA) QFN package, and operates over a free-air temperature range of -40°C to 85°C .

**TPS62111
Efficiency vs Output Current**

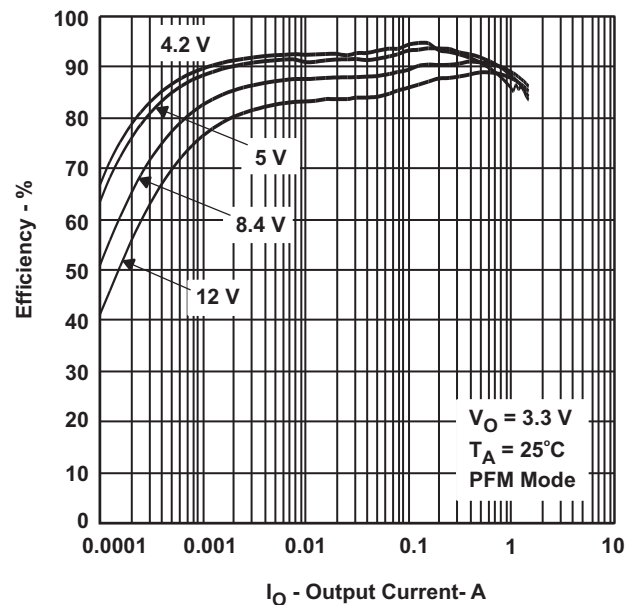

Please be aware that an important notice concerning availability, standard warranty, and use in critical applications of Texas Instruments semiconductor products and disclaimers thereto appears at the end of this data sheet.



This integrated circuit can be damaged by ESD. Texas Instruments recommends that all integrated circuits be handled with appropriate precautions. Failure to observe proper handling and installation procedures can cause damage.

ESD damage can range from subtle performance degradation to complete device failure. Precision integrated circuits may be more susceptible to damage because very small parametric changes could cause the device not to meet its published specifications.

ORDERING INFORMATION

PLASTIC QFN 16 PIN ⁽¹⁾ (RSA)	OUTPUT VOLTAGE	LBI/LBO FUNCTIONALITY	MARKING
TPS62110	Adjustable 1.2 V to 16 V	Standard	TPS62110
TPS62111	Fixed 3.3 V	Standard	TPS62111
TPS62112	Fixed 5 V	Standard	TPS62112
TPS62113	Adjustable 1.2 V to 16 V	Enhanced	TPS62113

- (1) The RSA package is available in tape and reel. Add R suffix (TPS62110RSAR) to order quantities of 3000 parts per reel. Add T suffix (TPS62110RSAT) to order quantities of 250 parts per reel.

ABSOLUTE MAXIMUM RATINGS⁽¹⁾

over operating free-air temperature range (unless otherwise noted)

		VALUE
V_{CC}	Supply voltage at VIN, VINA	-0.3 V to 20 V
V_I	Voltage at SW	-1 V to 20 V
	Voltage at EN, SYNC, LBO, PG	-0.3 V to 20 V
	Voltage at LBI, FB	-0.3 V to 7 V
I_O	Output current at SW	2400 mA
T_J	Maximum junction temperature	150°C
T_A	Operating free-air temperature	-40°C to 85°C
T_{stg}	Storage temperature	-65°C to 150°C
ESD	Human Body Model (HBM)	2 kV
	Charged Device Model (CDM)	500 V

- (1) Stresses beyond those listed under *absolute maximum ratings* may cause permanent damage to the device. These are stress ratings only and functional operation of the device at these or any other conditions beyond those indicated under *recommended operating conditions* is not implied. Exposure to absolute-maximum-rated conditions for extended periods may affect device reliability.

THERMAL INFORMATION

THERMAL METRIC ⁽¹⁾		TPS6211x	UNITS
		RSA (16-PINS)	
θ_{JA}	Junction-to-ambient thermal resistance	48.2	°C/W
θ_{JcTop}	Junction-to-case (top) thermal resistance	45.4	
θ_{JB}	Junction-to-board thermal resistance	16.3	
Ψ_{JT}	Junction-to-top characterization parameter	0.5	
Ψ_{JB}	Junction-to-board characterization parameter	16.4	
θ_{JcBot}	Junction-to-case (bottom) thermal resistance	3.3	

- (1) For more information about traditional and new thermal metrics, see the *IC Package Thermal Metrics* application report, [SPRA953](#).

RECOMMENDED OPERATING CONDITIONS

		MIN	NOM	MAX	UNIT
V_{CC}	Supply voltage at VIN, VINA	3.1		17	V
	Maximum voltage at PG, LBO, EN, SYNC			17	V
T_J	Operating junction temperature	-40		125	°C

ELECTRICAL CHARACTERISTICS

 $V_I = 12\text{ V}$, $V_O = 3.3\text{ V}$, $I_O = 600\text{ mA}$, $EN = V_I$, $T_A = -40^\circ\text{C}$ to 85°C (unless otherwise noted)

PARAMETER		TEST CONDITIONS	MIN	TYP	MAX	UNIT
SUPPLY CURRENT						
V_I	Input voltage range		3.1		17	V
$I_{(Q)}$	Operating quiescent current	$I_O = 0\text{ mA}$, SYNC = GND, $V_I = 7.2\text{ V}$, $T_A = 25^\circ\text{C}$ ⁽¹⁾		20		μA
		$I_O = 0\text{ mA}$, SYNC = GND, $V_I = 17\text{ V}$ ⁽¹⁾		23	26	
$I_{(LBI)}$	Quiescent current with enhanced LBI comparator version (TPS62113 only).	EN = V_I , LBI = GND		10		μA
$I_{(SD)}$	Shutdown current	EN = GND		1.5	5	μA
		EN = GND, $T_A = 25^\circ\text{C}$, $V_I = 7.2\text{ V}$		1.5	3	
ENABLE						
V_{IH}	EN high-level input voltage		1.3			V
V_{IL}	EN low-level input voltage				0.3	V
	EN trip-point hysteresis			170		mV
$I_{(kg)}$	EN input leakage current	EN = GND or V_I , $V_I = 12\text{ V}$		0.01	0.2	μA
$I_{(EN)}$	EN input current	$0.6\text{ V} \leq V_{(EN)} \leq 4\text{ V}$		10	20	μA
$V_{(UVLO)}$	Undervoltage lockout threshold	Input voltage falling	2.8	3	3.1	V
	Undervoltage lockout hysteresis			250	300	mV
POWER SWITCH						
$r_{DS(ON)}$	P-channel MOSFET on-resistance	$V_I \geq 5.4\text{ V}$; $I_O = 350\text{ mA}$		165	250	$\text{m}\Omega$
		$V_I = 3.5\text{ V}$; $I_O = 200\text{ mA}$		340		
		$V_I = 3\text{ V}$; $I_O = 100\text{ mA}$		490		
$I_{(kg)}$	P-channel MOSFET leakage current	$V_{DS} = 17\text{ V}$		0.1	1	μA
$I_{(LIMF)}$	P-channel MOSFET current limit	$V_I = 7.2\text{ V}$, $V_O = 3.3\text{ V}$	2100	2400	2600	mA
$r_{DS(ON)}$	N-channel MOSFET on-resistance	$V_I \geq 5.4\text{ V}$; $I_O = 350\text{ mA}$		145	200	$\text{m}\Omega$
		$V_I = 3.5\text{ V}$; $I_O = 200\text{ mA}$		170		
		$V_I = 3\text{ V}$; $I_O = 100\text{ mA}$		200		
$I_{(kg)}$	N-channel MOSFET leakage current	$V_{DS} = 17\text{ V}$		0.1	2	μA
PG OUTPUT, LBI, LBO						
$V_{(PG)}$	Power-good trip voltage			$V_O - 1.6\%$		V
	Power-good delay time	V_O ramping positive		50		μs
		V_O ramping negative		200		
V_{OL}	PG, LBO output-low voltage	$V_{(FB)} = 0.8 \times V_O$ nominal, $I_{OL} = 1\text{ mA}$			0.3	V
I_{OL}	PG, LBO sink current			1		mA
$I_{(kg)}$	PG, LBO output leakage current	$V_{(FB)} = V_O$ nominal, $V_{(LBI)} = V_I$		0.01	0.25	μA
	Minimum supply voltage for valid power good, LBI, LBO signal			3		V
V_{LBI}	LBI input trip voltage	Input voltage falling		1.256		V
$I_{(kg)}$	LBI input leakage current			10	100	nA
	LBI input trip-point accuracy				1.5%	
$V_{LBI,HYS}$	Low-battery input hysteresis			25		mV

(1) Device is not switching.

ELECTRICAL CHARACTERISTICS (continued)

$V_I = 12\text{ V}$, $V_O = 3.3\text{ V}$, $I_O = 600\text{ mA}$, $EN = V_I$, $T_A = -40^\circ\text{C}$ to 85°C (unless otherwise noted)

PARAMETER		TEST CONDITIONS	MIN	TYP	MAX	UNIT
OSCILLATOR						
f_S	Oscillator frequency		900	1000	1100	kHz
$f_{(\text{SYNC})}$	Synchronization range	CMOS-logic clock signal on SYNC pin	800		1400	kHz
V_{IH}	SYNC high-level input voltage		1.5			V
V_{IL}	SYNC low-level input voltage				0.3	V
I_{lkg}	SYNC input leakage current	SYNC = GND or VIN		0.01	0.2	μA
	SYNC trip-point hysteresis			170		mV
I_{lkg}	SYNC input leakage current	$0.6\text{ V} \leq V_{(\text{SYNC})} \leq 4\text{ V}$		10	20	μA
	Duty cycle of external clock signal		30%		90%	
OUTPUT						
V_O	Adjustable output voltage range	TPS62110 TPS62113	1.153		16	V
V_{FB}	Feedback voltage	TPS62110 TPS62113		1.153		V
I_{lkg}	FB input leakage current	TPS62110 TPS62113		10	100	nA
	Feedback voltage tolerance	TPS62110 TPS62113	$V_I = 3.1\text{ V to }17\text{ V};$ $0\text{ mA} < I_O < 1500\text{ mA}^{(2)}$		-2%	2%
	Fixed output-voltage tolerance ⁽³⁾	TPS62111	$V_I = 3.8\text{ V to }17\text{ V};$ $0\text{ mA} < I_O < 1500\text{ mA}^{(2)}$		-3%	3%
		TPS62112	$V_I = 5.5\text{ V to }17\text{ V};$ $0\text{ mA} < I_O < 1500\text{ mA}^{(2)}$		-3%	3%
I_O	Maximum output current	$V_I \geq 3\text{ V}$ (once undervoltage lockout voltage exceeded)		100		mA
		$V_I \geq 3.5\text{ V}$		500		
		$V_I \geq 4.3\text{ V}$		1200		
		$V_I \geq 6\text{ V}$		1500		
	Current into internal voltage divider for fixed voltage versions			5		μA
η	Efficiency	$V_I = 7.2\text{ V}; V_O = 3.3\text{ V}; I_O = 600\text{ mA}$		92%		
		$V_I = 12\text{ V}, V_O = 5\text{ V}, I_O = 600\text{ mA}$				
	Duty-cycle range for main switches	at 1 MHz	10%		100%	
	Minimum t_{on} time for main switch		100			ns
T_{SD}	Shutdown temperature			145		$^\circ\text{C}$
	Start-up time	$I_O = 800\text{ mA}, V_I = 12\text{ V}, V_O = 3.3\text{ V}$		1		ms

- (2) The maximum output current depends on the input voltage. See the *maximum output current* for further restrictions on the minimum input voltage.
- (3) The output voltage accuracy includes line and load regulation over the full temperature range $T_A = -40^\circ\text{C}$ to 85°C . See the [No-Load Operation](#) section in this data sheet.

DEVICE INFORMATION

PIN ASSIGNMENT TOP VIEW

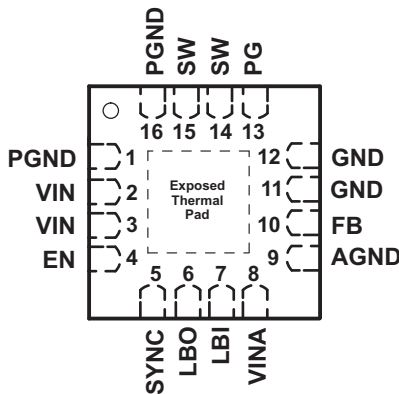

TERMINAL FUNCTIONS

TERMINAL		I/O	DESCRIPTION
NAME	NO.		
AGND	9	I	Analog ground, connect to GND and PGND
EN	4	I	Enable. A logic high enables the converter; logic low forces the device into shutdown mode reducing the supply current to less than 2 μ A. Do not leave floating.
FB	10	I	Feedback pin for the fixed output voltage versions. Connect to V_{OUT} for these devices. For the adjustable versions, an external resistive divider is connected to this pin. The internal voltage divider is disabled for the adjustable versions.
GND	11, 12	I	Ground
LBI	7	I	Low-battery input. Do not leave floating.
LBO	6	O	Open-drain, low-battery output. This pin is pulled low if LBI is below its threshold. If not used, the pin may be left floating or connected to GND.
PG	13	O	Power good comparator output. This is an open-drain output. A pullup resistor should be connected between PG and V_{OUT} . The output goes high when the output voltage is greater than 98.4% of the nominal value. If not used, the pin may be left floating or connected to GND.
PGND	1, 16	I	Power ground. Connect all power grounds to this pin.
SW	14, 15	O	Connect the inductor to this pin. This pin is the switch pin and connected to the drain of the internal power MOSFETS.
SYNC	5	I	Input for synchronization to external clock signal. Synchronizes the converter switching frequency to an external clock signal with CMOS level. Also controls power save mode by being tied high or low: SYNC = HIGH: Low-noise mode enabled, fixed frequency PWM operation is forced SYNC = LOW (GND): Power save mode enabled, PFM/PWM Mode enabled
VIN	2, 3	I	Supply voltage input (power stage)
VINA	8	I	Supply voltage input (support circuits)
Exposed Thermal pad			Connect to AGND. Must be soldered to achieve appropriate power dissipation and mechanical reliability.

FUNCTIONAL BLOCK DIAGRAM

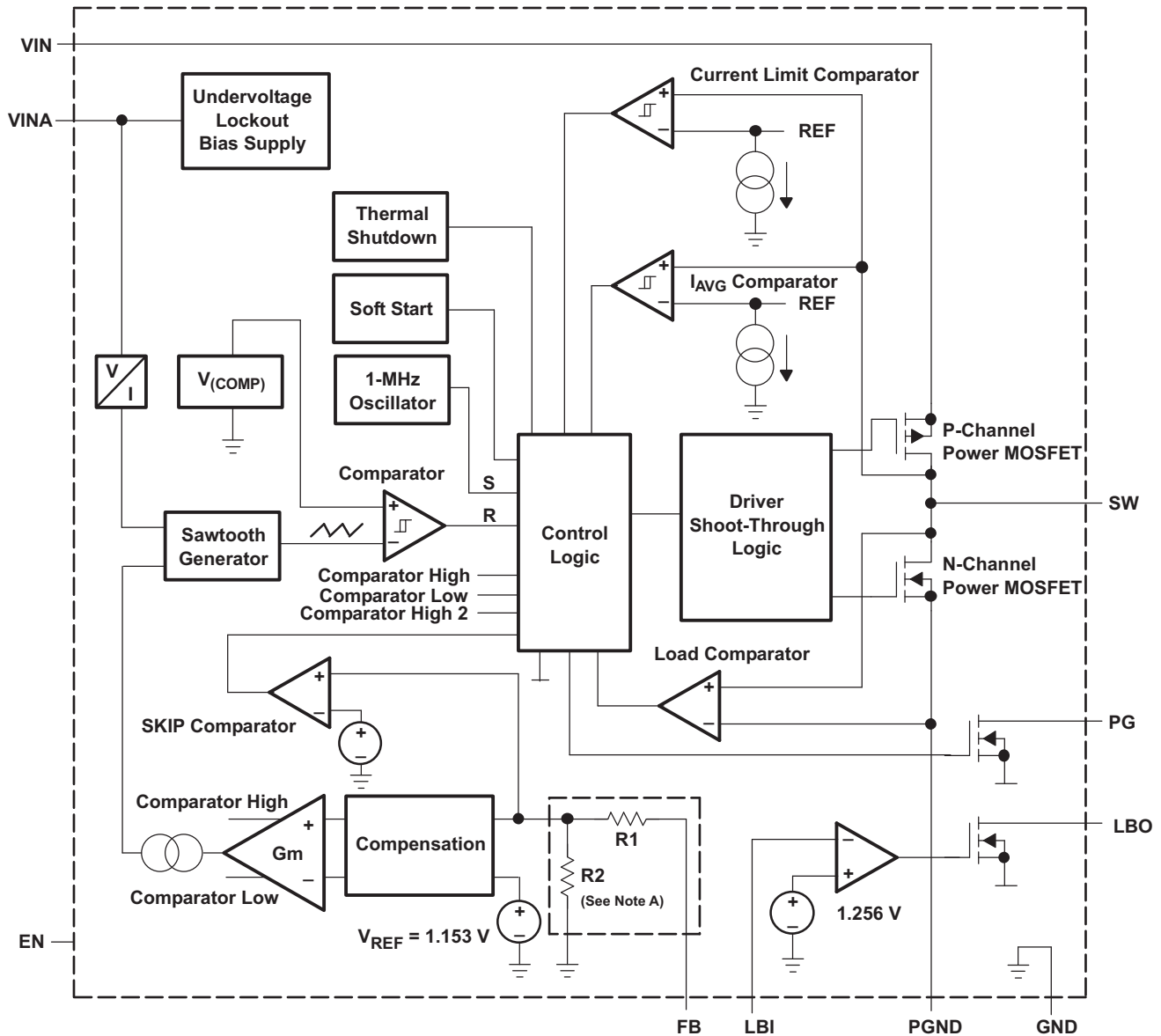

- A. For the adjustable version (TPS62110 and TPS62113), the internal feedback divider is disabled and the FB pin is directly connected to the internal compensation block.

Table of Graphs

			FIGURE
Efficiency	vs	Output current (5 V)	1, 2
Efficiency	vs	Output current (3.3 V)	3, 4, 5
Maximum output current	vs	Input voltage	6
Efficiency	vs	Output current (1.8 V)	7, 8
Efficiency	vs	Output current (1.5 V)	9, 10
Line transient response			11
Load transient response			12
Output ripple			13
Start-up timing			14
Switching frequency	vs	Input voltage	15
Quiescent current	vs	Input voltage	16

Typical Characteristics

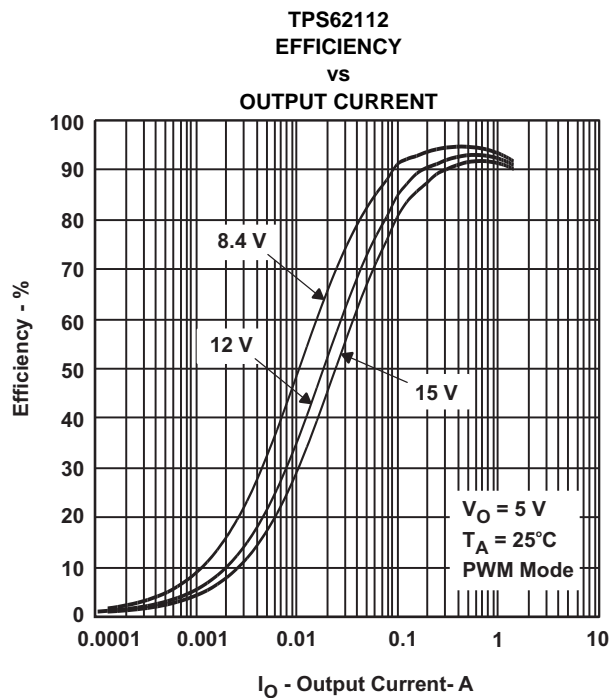

Figure 1.

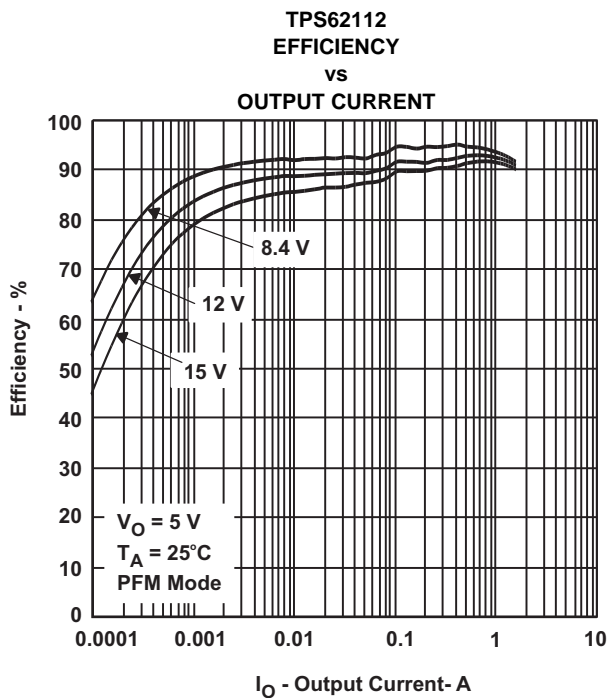

Figure 2.

Typical Characteristics (continued)

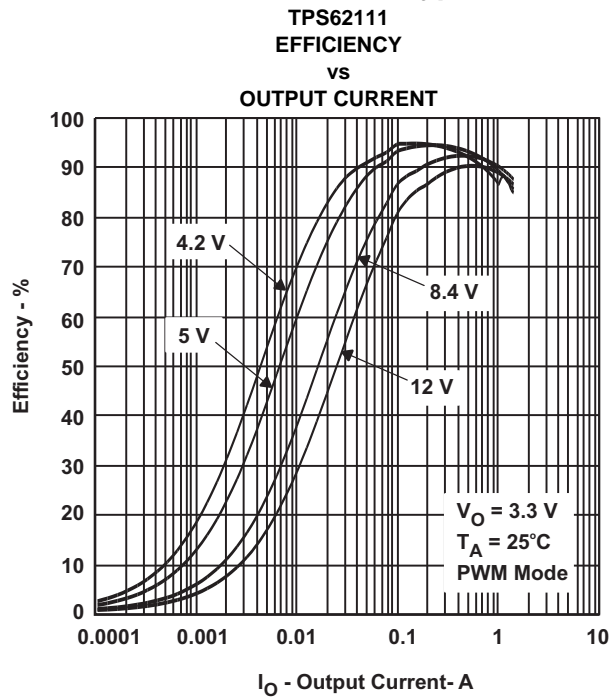

Figure 3.

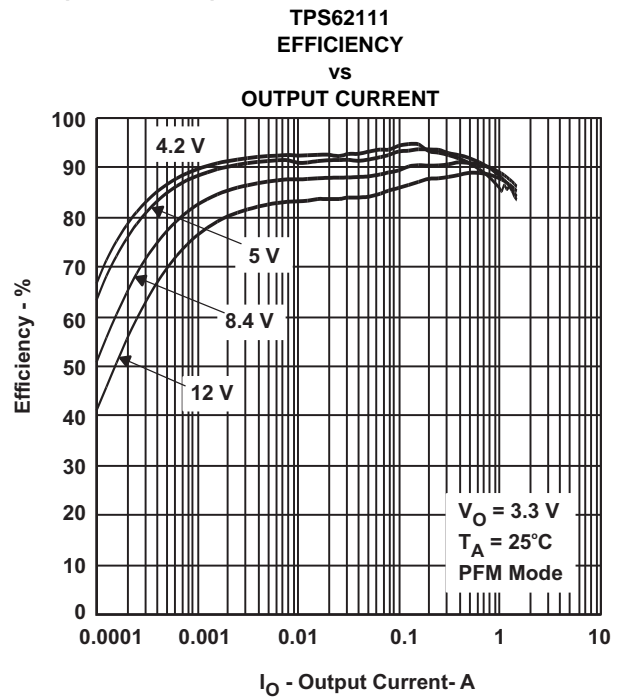

Figure 4.

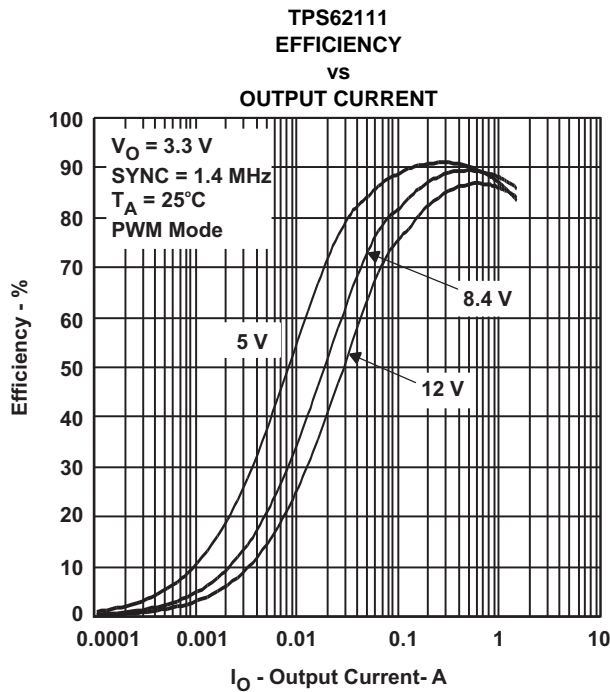

Figure 5.

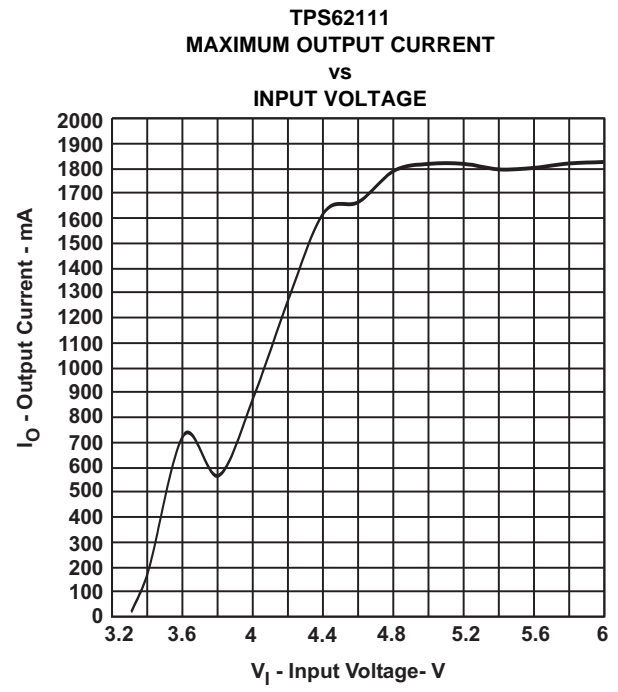

Figure 6.

Typical Characteristics (continued)

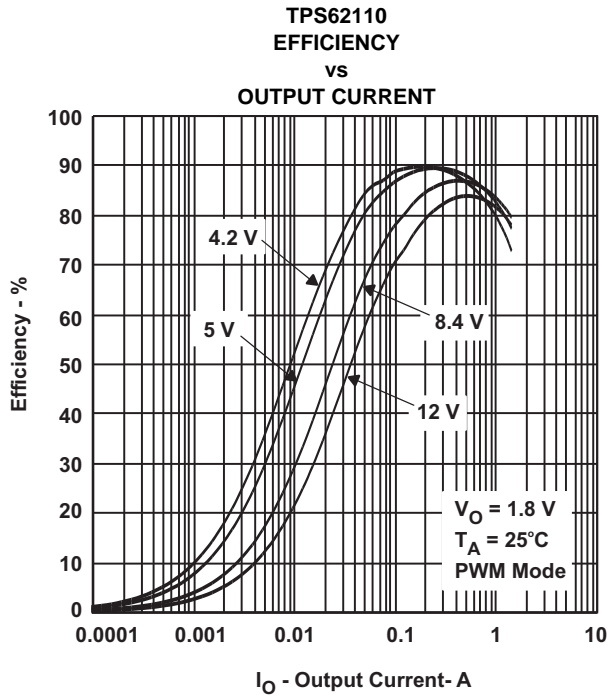

Figure 7.

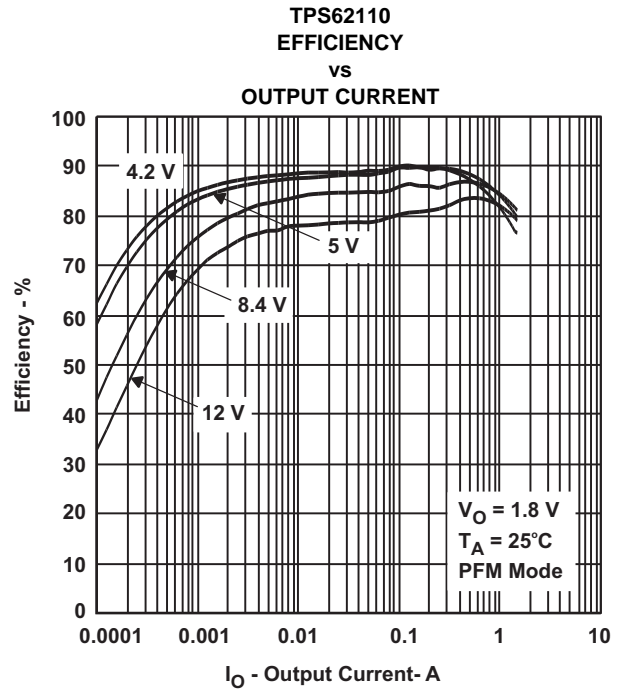

Figure 8.

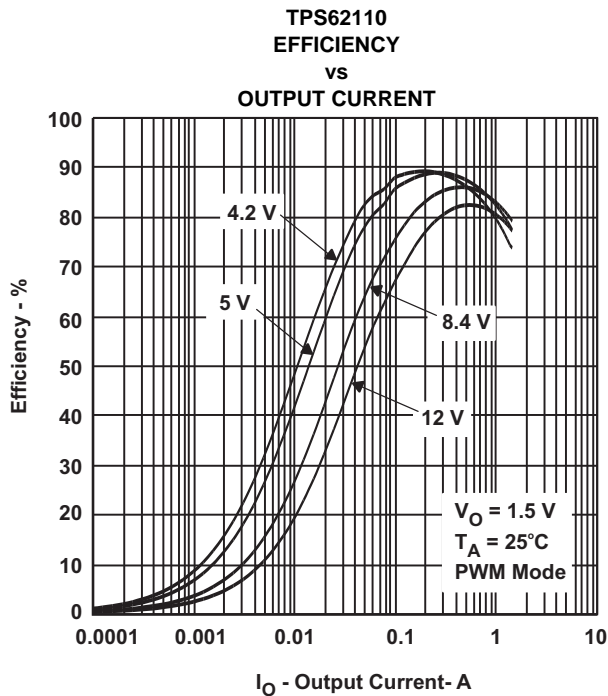

Figure 9.

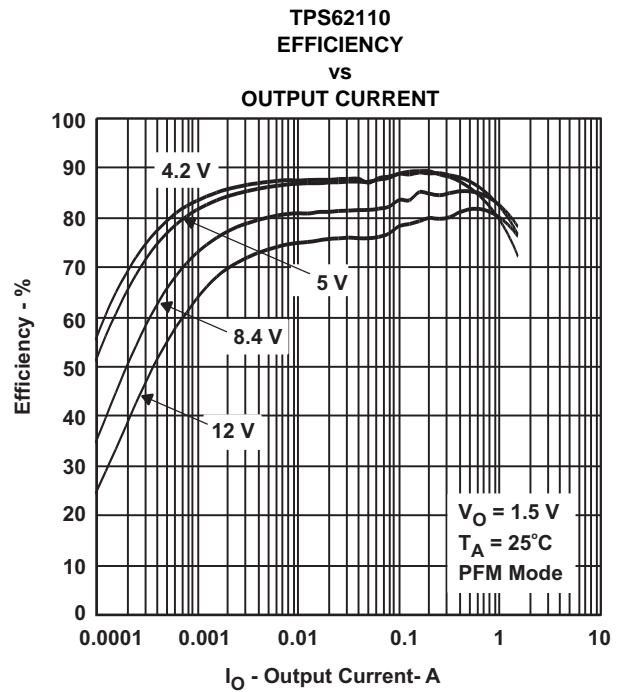
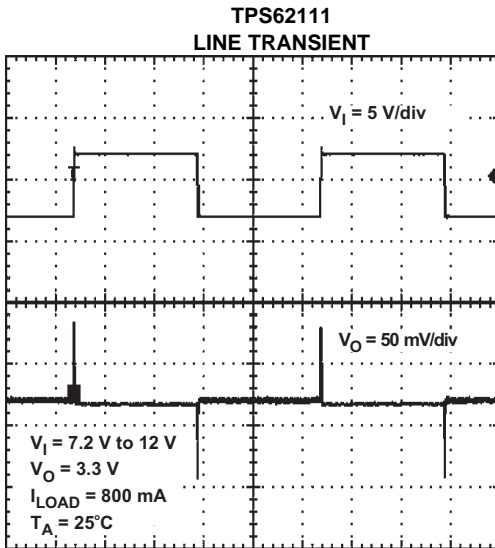

Figure 10.

Typical Characteristics (continued)



t - Time = 2 ms/div

Figure 11.

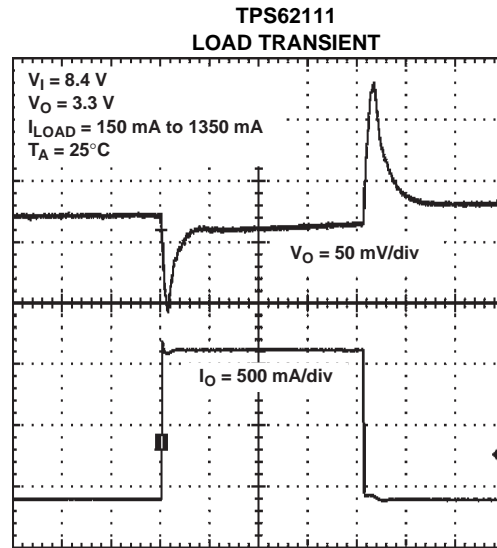

t - Time = 20 $\mu\text{s/div}$

Figure 12.

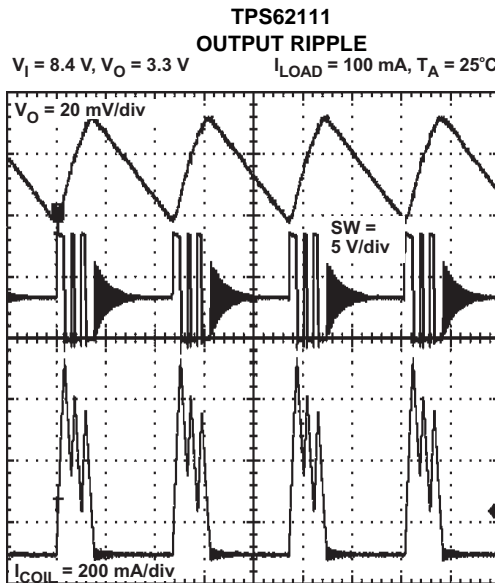

t - Time = 5 ms/div

Figure 13.

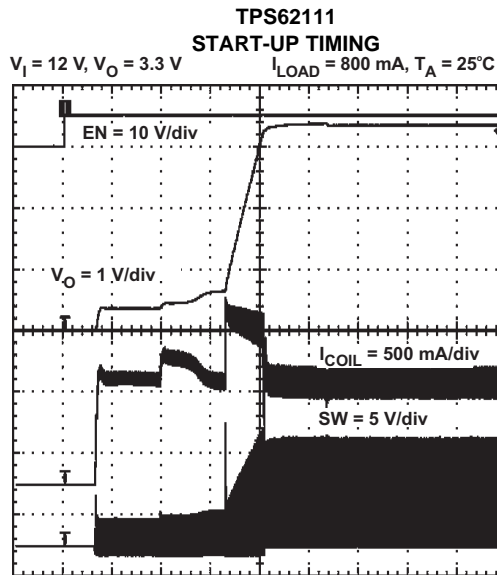

t - Time = 200 ms/div

Figure 14.

Typical Characteristics (continued)

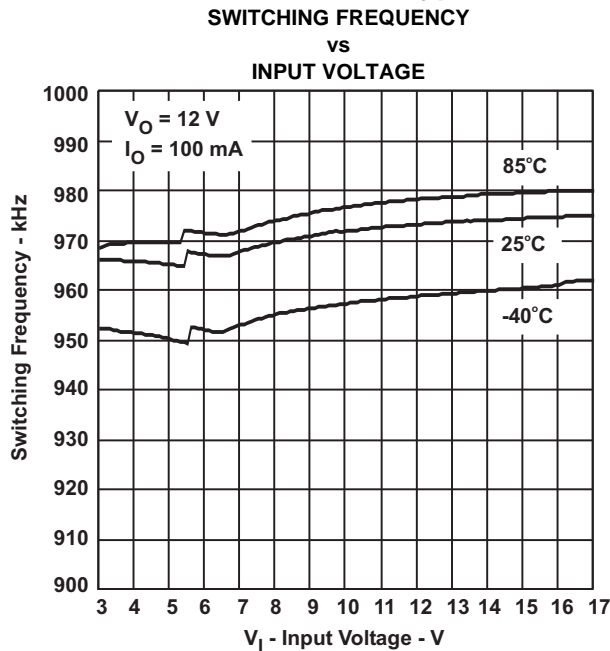

Figure 15.

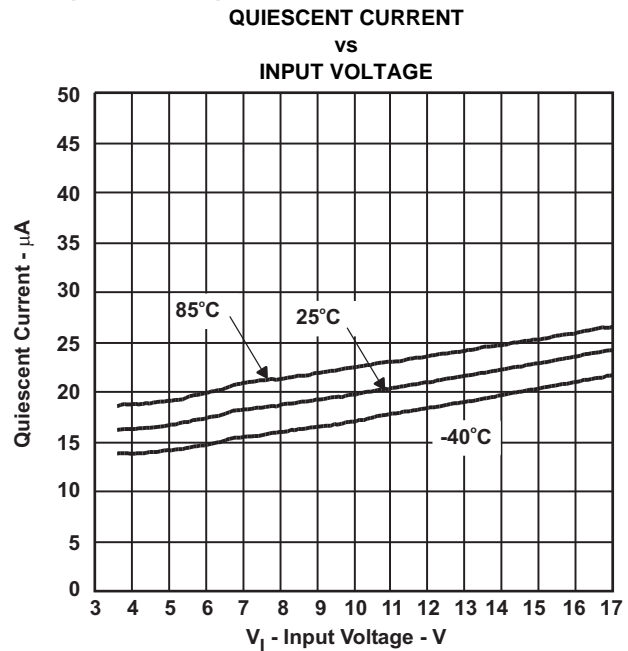

Figure 16.

The graphs were generated using the EVM with the setup according to Figure 17, unless otherwise noted. The output voltage divider was adjusted according to Table 4. Graphs for an output voltage of 5 V and 3.3 V were generated using TPS62111 and TPS62112 with $R1 = 0\ \Omega$ and $R2 = \text{open}$.

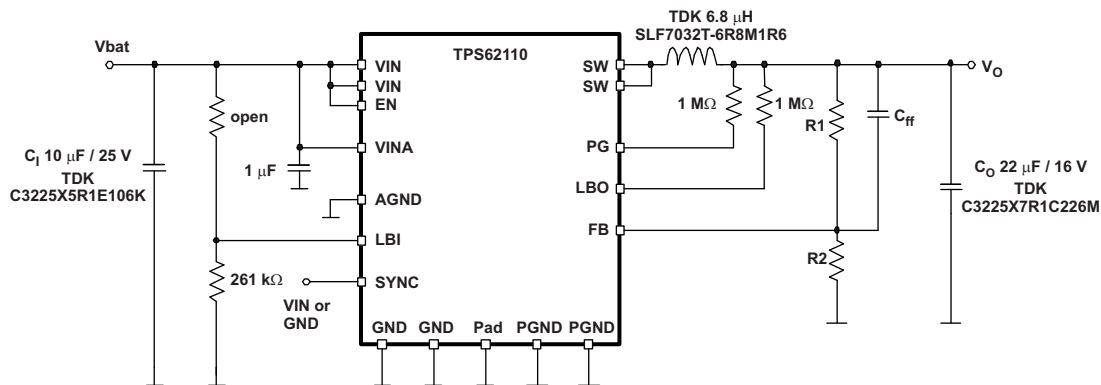

Figure 17. Test Setup

Graphs with $V_O = 1.8\text{ V}$ were taken using the circuit according to Figure 21.

DETAILED DESCRIPTION

OPERATION

The TPS6211x is a synchronous step-down converter that operates with a 1-MHz fixed-frequency pulse-width modulation (PWM) at moderate-to-heavy load currents and enters the power-save mode at light load current.

During PWM operation, the converter uses a unique fast-response voltage-mode control scheme with input-voltage feedforward. Good line and load regulation is achieved with the use of small input and output ceramic capacitors. At the beginning of each clock cycle initiated by the clock signal (S), the P-channel MOSFET switch is turned on, and the inductor current ramps up until the comparator trips and the control logic turns the switch off. The switch is turned off by the current-limit comparator if the current limit of the P-channel switch is exceeded. After the dead time prevents current shoot through, the N-channel MOSFET rectifier is turned on, and the inductor current ramps down. The next cycle is initiated by the clock signal turning off the N-channel rectifier, and turning on the P-channel switch.

The error amplifier as well as the input voltage determines the rise time of the sawtooth generator. Therefore, any change in input voltage or output voltage directly controls the duty cycle of the converter, giving a very good line- and load-transient regulation.

CONSTANT-FREQUENCY MODE OF OPERATION (SYNC = HIGH)

In constant-frequency mode, the output voltage is regulated by varying the duty cycle of the PWM signal in the range of 100% to 10%. Connecting the SYNC pin to a voltage greater than 1.5 V forces the converter to operate permanently in the PWM mode even at light or no-load currents. The advantage is that the converter operates with a fixed switching frequency that allows simple filtering of the switching frequency for noise-sensitive applications. In this mode, the efficiency is lower compared to the power-save mode during light loads. The N-MOSFET of the devices stays on even when the current into the output drops to zero. This prevents the device from going into discontinuous mode, and the device transfers unused energy back to the input. Therefore, there is no ringing at the output, which usually occurs in discontinuous mode. The duty cycle range in constant-frequency mode is 100% to 10%.

POWER-SAVE MODE OF OPERATION (SYNC = LOW)

As the load current decreases, the converter enters the power-save mode of operation. During power-save mode, the converter operates with reduced switching frequency in pulse-frequency modulation (PFM), and with a minimum quiescent current to maintain high efficiency. Whenever the average output current goes below the skip threshold, the converter enters the power-save mode. The average current depends on the input voltage. It is about 200 mA at low input voltages and up to 400 mA with maximum input voltage. The average output current must be below the threshold for at least 32 clock cycles to enter the power-save mode. During the power-save mode, the output voltage is monitored with a comparator, and the output voltage is regulated to a typical value between the nominal output voltage and 0.8% above the nominal output voltage. When the output voltage falls below the nominal output voltage, the P-channel switch turns on. The P-channel switch is turned off as the peak switch current is reached. The N-channel rectifier is turned on, and the inductor current ramps down. As the inductor current approaches zero, the N-channel rectifier is turned off and the switch is turned on starting the next pulse. When the output voltage cannot be reached with a single pulse, the device continues to switch with its normal operating frequency until the comparator detects the output voltage to be 0.8% above the nominal output voltage. This control method reduces the quiescent current to 20 μ A (typical), and reduces the switching frequency to a minimum that achieves the highest converter efficiency. [Figure 18](#) shows the typical Power-Save mode operation.

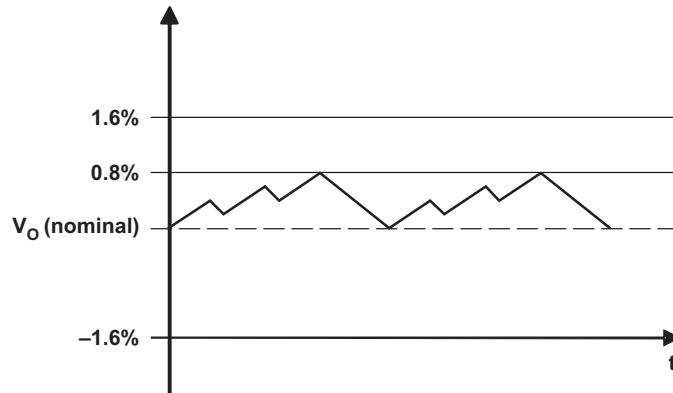

Figure 18. Power-Save Mode Output-Voltage Thresholds

The typical PFM (SKIP) current threshold for the TPS6211x is given by:

$$I_{\text{SKIP}} \approx \frac{V_I}{25 \Omega} \quad (1)$$

Equation 1 is valid for input voltages up to 7 V. For higher voltages, the skip current threshold is not increased further. The converter enters the fixed-frequency PWM mode as soon as the output voltage falls below $V_O - 1.6%$ (nominal).

SOFT START

The TPS6211x has an internal soft-start circuit that limits the inrush current during start-up. This prevents possible voltage drops of the input voltage when a battery or a high-impedance power source is connected to the input of the TPS6211x.

The soft start is implemented as a digital circuit increasing the switch current in steps of 300 mA, 600 mA, and 1200 mA for 250 μsec each. Then, the switch current limit is set to 2.4 A typical. Therefore, the start-up time depends on the output capacitor and load current. Typical start-up time with a 22- μF output capacitor and 800-mA load current is 1 ms.

The TPS6211x can start into a pre-biased output. During monotonic pre-biased start up, the N-Channel MOSFET is not allowed to turn on until the internal ramp of the device sets an output voltage above the pre-bias voltage.

100% DUTY-CYCLE, LOW-DROPOUT OPERATION

The TPS6211x offers the lowest possible input-to-output voltage difference while still maintaining operation with the use of the 100% duty-cycle mode. In this mode, the P-channel switch is constantly turned on. This is particularly useful in battery-powered applications to achieve the longest operation time, taking full advantage of the whole battery voltage range. The minimum input voltage to maintain regulation depends on the load current and output voltage, and is calculated as:

$$V_I \text{ min} = V_O + I_O \text{ max} \times (r_{\text{DS(on)}} \text{ max} + R_{\text{(L)}}) \quad (2)$$

with:

$I_O \text{ max}$ = maximum output current

$r_{\text{DS(on)}} \text{ max}$ = maximum P-channel switch $r_{\text{DS(on)}}$

$R_{\text{(L)}}$ = dc resistance of the inductor

V_O = lowest output voltage that the load can accept.

ENABLE

A logic low on EN forces the TPS6211x into shutdown. In shutdown, the power switch, drivers, voltage reference, oscillator, and all other functions are turned off. The LBO pin is high impedance, while PG is held low. The supply current is reduced to less than 2 μA in the shutdown mode. When the device is in thermal shutdown, the band gap is forced to be switched on even if the device is set into shutdown by pulling EN to GND.

If an output voltage is present when the device is disabled, which could be due to an external voltage source or a super capacitor, the reverse leakage current is specified under electrical characteristics. Pulling the enable pin high starts up the TPS6211x with the soft start. If the EN pin is connected to any voltage other than V_1 or GND, an increased leakage current of typically 10 μA and up to 20 μA can occur. See [SLVA295](#) for details.

UNDERVOLTAGE LOCKOUT

The undervoltage lockout circuit prevents the device from misoperation at low-input voltages. It prevents the converter from turning on the switch or rectifier MOSFET under undefined conditions. The minimum input voltage to start up the TPS6211x is 3.4 V (worst case). The device shuts down at 2.8 V minimum.

THERMAL SHUTDOWN

The junction temperature (T_J) of the device is monitored by an internal temperature sensor. If T_J exceeds 145°C typical, the device goes into thermal shutdown. Both the high-side and low-side power FETs are turned off and PG goes high impedance. When T_J decreases by typically 10°C, the converter resumes normal operation.

SYNCHRONIZATION

If no clock signal is applied, the converter operates with a typical switching frequency of 1 MHz. It is possible to synchronize the converter to an external clock within a frequency range from 0.8 MHz to 1.4 MHz only. The device automatically detects the rising edge of the first clock and synchronizes immediately to the external clock. If the clock signal is stopped, the converter automatically switches back to the internal clock and continues operation. The switch over is initiated if no rising edge on the SYNC pin is detected for a duration of four clock cycles. Therefore, the maximum delay time can be 6.25 μs if the internal clock has its minimum frequency of 800 kHz.

If the device is synchronized to an external clock, the power-save mode is disabled, and the devices stay in forced PWM mode.

Connecting the SYNC pin to the GND pin enables the power-save mode. The converter operates in the PWM mode at moderate-to-heavy loads, and in the PFM mode during light loads, which maintains high efficiency over a wide load-current range.

POWER-GOOD COMPARATOR

The power-good (PG) comparator is an open-drain output capable of sinking 1 mA (typical). The PG is only active when the device is enabled (EN = high). When the device is disabled (EN = low), the PG pin is pulled to GND.

The PG output is only valid after a 250- μs delay when the device is enabled and the supply voltage is greater than the undervoltage lockout $V_{(UVLO)}$.

The PG pin becomes active-high when the output voltage exceeds 98.4% (typical) of its nominal value. Leave the PG pin floating or grounded when not used.

LOW-BATTERY DETECTOR (Standard Version)

The low-battery output (LBO) is an open-drain type which goes low when the voltage at the low-battery input (LBI) falls below the trip point of 1.256 V $\pm 1.5\%$. The voltage at which the low-battery warning is issued can be adjusted with a resistive divider as shown in [Figure 19](#). The sum of resistors ($R_1 + R_2$) as well as the sum of ($R_5 + R_6$) is recommended to be in the 100-k Ω to 1-M Ω range for high efficiency at low output current. An external pullup resistor can be connected to V_O , or any other voltage rail in the voltage range of 0 V to 17 V. During start-up, the LBO output signal is invalid for the first 500 μs . LBO is high-impedance when the device is disabled. If the low-battery comparator function is not used, connect LBI to ground. The low-battery detector is disabled when the device is disabled.

When the LBI is used to supervise the battery voltage and shut down the TPS6211x at low-input voltages, the battery voltage rises when its current drops to zero. The implemented hysteresis on the LBI pin may not be sufficient for all types of batteries. Figure 19 shows how an additional external hysteresis can be implemented. See SLVA373 for details.

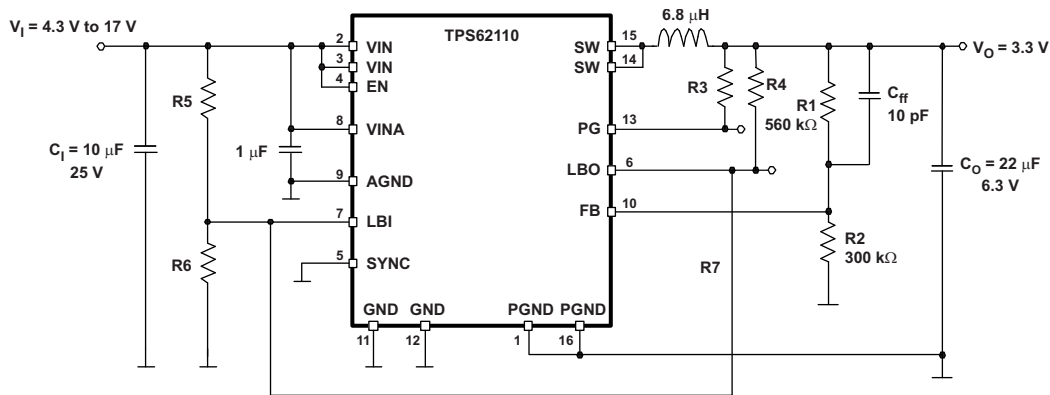

Figure 19. LBI With Increased Hysteresis

ENABLE/Low-Battery Detector (Enhanced Version) TPS62113 Only

The TPS62113 offers an enhanced LBI functionality to provide a precise, user-programmable undervoltage shutdown. No additional supply voltage supervisor (SVS) is needed to provide this function. When the enable (EN) pin is pulled high, only the internal bandgap voltage reference is switched on to provide a reference source for the LBI comparator. As long as the voltage at LBI is less than the LBI trip point, all other internal circuits are shut down, reducing the supply current to 10 µA. As soon as input voltage at LBI rises above the LBI trip point of 1.256 V, the device is completely enabled and starts switching.

This functionality is the only difference between the TPS62110 and TPS62113 devices.

NO-LOAD OPERATION

When the converter operates in the forced PWM mode and there is no load connected to the output, the converter regulates the output voltage by allowing the inductor current to reverse for a short time.

THEORY OF OPERATION / DESIGN PROCEDURE

External Component Selection

The control loop of the TPS6211x family requires a certain value for the output inductor and the output capacitor for stable operation. As long as the nominal value of $L \times C \geq 6.2 \mu\text{H} \times 22 \mu\text{F}$, the control loop has enough phase margin and the device is stable. Reducing the inductor value without increasing the output capacitor (or vice versa) may cause stability problems. There are applications where it may be useful to increase the value of the output capacitor, and so on, for a low-transient output-voltage change. From a stability point of view, the inductor value could be decreased to keep the $L \times C$ product constant. However, there are drawbacks if the inductor value is decreased. A low inductor value causes a high inductor ripple current, and therefore reduces the maximum dc output current. Table 1 gives the advantages and disadvantages when designing the inductor and output capacitor.

Table 1. Advantages and Disadvantages When Designing the Inductor and Output Capacitor

	INFLUENCE ON STABILITY	ADVANTAGE	DISADVANTAGE
Increase Cout (>22 µF)	Uncritical	Less output voltage ripple Less output voltage overshoot / undershoot during load transient	None
Decrease Cout (<22 µF)	Critical Increase inductor value > 6.8 µH also	None	Higher output voltage ripple High output voltage overshoot / undershoot during load transient Less gain and phase margin
Increase L (>6.8 µH)	Uncritical	Less inductor current ripple Higher dc output current possible if operated close to the current limit	More energy stored in the inductor → higher voltage overshoot during load transient Smaller current rise → higher voltage undershoot during load transient → do not decrease the value of Cout due to these effects
Decrease L (<6.8 µH)	Critical Increase output capacitor value > 22 µF also	Small voltage overshoot / undershoot during load transient	High inductor-current ripple especially at high input voltage and low output voltage

Inductor Selection

As shown in [Table 1](#), the inductor value can be increased to higher values. For good performance, the peak-to-peak inductor-current ripple should be less than 30% of the maximum dc output current. Especially at input voltages above 12 V, it makes sense to increase the inductor value in order to keep the inductor-current ripple low. In such applications, the inductor value can be increased to 10 µH or 22 µH. Values above 22 µH should be avoided in order to keep the voltage overshoot during load transient in an acceptable range.

After choosing the inductor value, two additional inductor parameters should be considered:

1. current rating of the inductor
2. dc resistance

The dc resistance of the inductance directly influences the efficiency of the converter. Therefore, an inductor with lowest dc resistance should be selected for highest efficiency. In order to avoid saturation of the inductor, the inductor should be rated at least for the maximum output current plus the inductor ripple current which is calculated as:

$$\Delta I_L = V_O \times \frac{1 - \frac{V_O}{V_I}}{L \times f} \quad I_L \text{ max} = I_O \text{ max} + \frac{\Delta I_L}{2} \quad (3)$$

where:

f = Switching frequency (1000 kHz typical)

L = Inductor value

ΔI_L = Peak-to-peak inductor ripple current

$I_L(\text{max})$ = Maximum inductor current

The highest inductor current occurs at maximum V_I . A more-conservative approach is to select the inductor current rating just for the maximum switch current of the TPS6211x, which is 2.4 A (typically). See [Table 2](#) for recommended inductors.

Table 2. List of Inductors

MANUFACTURER	PART NO.	INDUCTANCE	DC RESISTANCE	SATURATION CURRENT
Coilcraft	MSS6132-682	6.8 μ H	65 m Ω (max)	1.5 A
	HA3808-AL	6.8 μ H	99 m Ω (typ)	4.4A
Epcos	B82462G4682M	6.8 μ H	50 m Ω (max)	1.5 A
Sumida	CDRH5D28-6R2	6.2 μ H	33 m Ω (typ)	1.8 A
TDK	SLF6028T-6R8M1R5	6.8 μ H	35 m Ω (typ)	1.5 A
	SLF7032T-6R8M1R6	6.8 μ H	41 m Ω (typ)	1.6 A
Würth	7447789006	6.8 μ H	44 m Ω (typ)	2.75 A
	7447779006	6.8 μ H	33 m Ω (typ)	3.3 A
	744053006	6.2 μ H	45 m Ω (typ)	1.8 A

OUTPUT-CAPACITOR SELECTION

A 22- μ F (typical) output capacitor is needed with a 6.8- μ H inductor. For an output voltage greater than 5 V, a 33- μ F (minimum) output capacitor is required for stability. For best performance, a low-ESR ceramic output capacitor is needed.

Just for completeness, the RMS ripple current is calculated as:

$$I_{\text{RMS}}(C_O) = V_O \times \frac{1 - \frac{V_O}{V_I}}{L \times f} \times \frac{1}{2 \times \sqrt{3}} \quad (4)$$

The overall output ripple voltage is the sum of the voltage spike caused by the output capacitor ESR plus the voltage ripple caused by charging and discharging the output capacitor:

$$\Delta V_O = V_O \times \frac{1 - \frac{V_O}{V_I}}{L \times f} \times \left(\frac{1}{8 \times C_O \times f} + R_{\text{ESR}} \right) \quad (5)$$

where the highest output-voltage ripple occurs at the highest input voltage V_I .

INPUT-CAPACITOR SELECTION

The nature of the buck converter is a pulsating input current; therefore, a low ESR input capacitor is required for best input voltage filtering and for minimizing the interference with other circuits caused by high input-voltage spikes. The input capacitor should have a minimum value of 10 μ F and can be increased without any limit for better input-voltage filtering. The input capacitor should be rated for the maximum input ripple current calculated as:

$$I_{\text{RMS}} = I_O \max \times \sqrt{\frac{V_O}{V_I} \times \left(1 - \frac{V_O}{V_I} \right)} \quad (6)$$

The worst-case RMS ripple current occurs at $D = 0.5$ and is calculated as: $I_{\text{RMS}} = I_O/2$. Ceramic capacitors show a good performance because of their low ESR value, and they are less sensitive against voltage transients compared to tantalum capacitors. Place the input capacitor as close as possible to the VIN and PGND pins of the IC for best performance.

An additional 1 μ F input capacitor is required from VINA to AGND. VIN and VINA must be connected to the same source. An RC filter from VIN to VINA is not recommended.

FEEDFORWARD-CAPACITOR SELECTION

The feedforward capacitor (C_{ff}) is needed to compensate for parasitic capacitance from the feedback pin to GND. Typically, a value of 4.7 pF to 22 pF is needed for an output voltage divider with a equivalent resistance (R_1 in parallel with R_2) in the 150-k Ω range. The value can be chosen based on best transient performance and lowest output-voltage ripple in PFM mode.

RECOMMENDED CAPACITORS

It is recommended that only X5R or X7R ceramic capacitors be used as input/output capacitors. Ceramic capacitors show a dc-bias effect. This effect reduces the effective capacitance when a dc-bias voltage is applied across a ceramic capacitor, as on the output and input capacitor of a dc/dc converter. The effect may lead to a significant capacitance drop, especially for high input/output voltages and small capacitor packages. See the manufacturer's data sheet about the performance with a dc bias voltage applied. It may be necessary to choose a higher voltage rating or nominal capacitance value in order to get the required value at the operating point. The capacitors listed in [Table 3](#) have been tested with the TPS6211x with good performance.

Table 3. List of Capacitors

MANUFACTURER	PART NUMBER	SIZE	VOLTAGE	CAPACITANCE	TYPE
Taiyo Yuden	TMK316BJ106KL	1206	25 V	10 μ F	Ceramic
	EMK325BJ226KM	1210	16 V	22 μ F	
TDK	C3225X5R1E106M	1210	25 V	10 μ F	Ceramic
	C3225X7R1C226M		16 V	22 μ F	
	C3216X5R1E106MT	1206	25 V	10 μ F	

Layout Consideration

A proper layout is critical for the operation of a switched mode power supply, even more at high switching frequencies. Therefore, the PCB layout of the TPS6211x demands careful attention to ensure operation and to get the performance specified. A poor layout can lead to issues like poor regulation (both line and load), stability and accuracy weaknesses, increased EMI radiation and noise sensitivity.

Provide low inductive and resistive paths for loops with high di/dt . Therefore, paths conducting the switched load current should be as short and wide as possible. The input and output capacitance should be placed as close as possible to the IC pins and parallel wiring over long distances as well as narrow traces should be avoided. Provide low capacitive paths (with respect to all other nodes) for wires with high dv/dt . Therefore, keep the SW node small. Loops which conduct an alternating current should outline an area as small as possible, as this area is proportional to the energy radiated.

Sensitive nodes like FB and LBI need to be connected with short wires and not nearby high dv/dt signals (that is, SW). The FB resistors, R_1 and R_2 , and LBI resistors, R_5 and R_6 , should be kept close to the IC and connect directly to those pins and AGND. The 1- μ F capacitor on VINA should connect directly from VINA to AGND.

All Grounds (GND, AGND, and PGND) are directly connected to the Exposed Thermal Pad. The Exposed Thermal Pad must be soldered to the circuit board for mechanical reliability and to achieve appropriate power dissipation.

See [Figure 20](#) for the recommended layout of the TPS6211x.

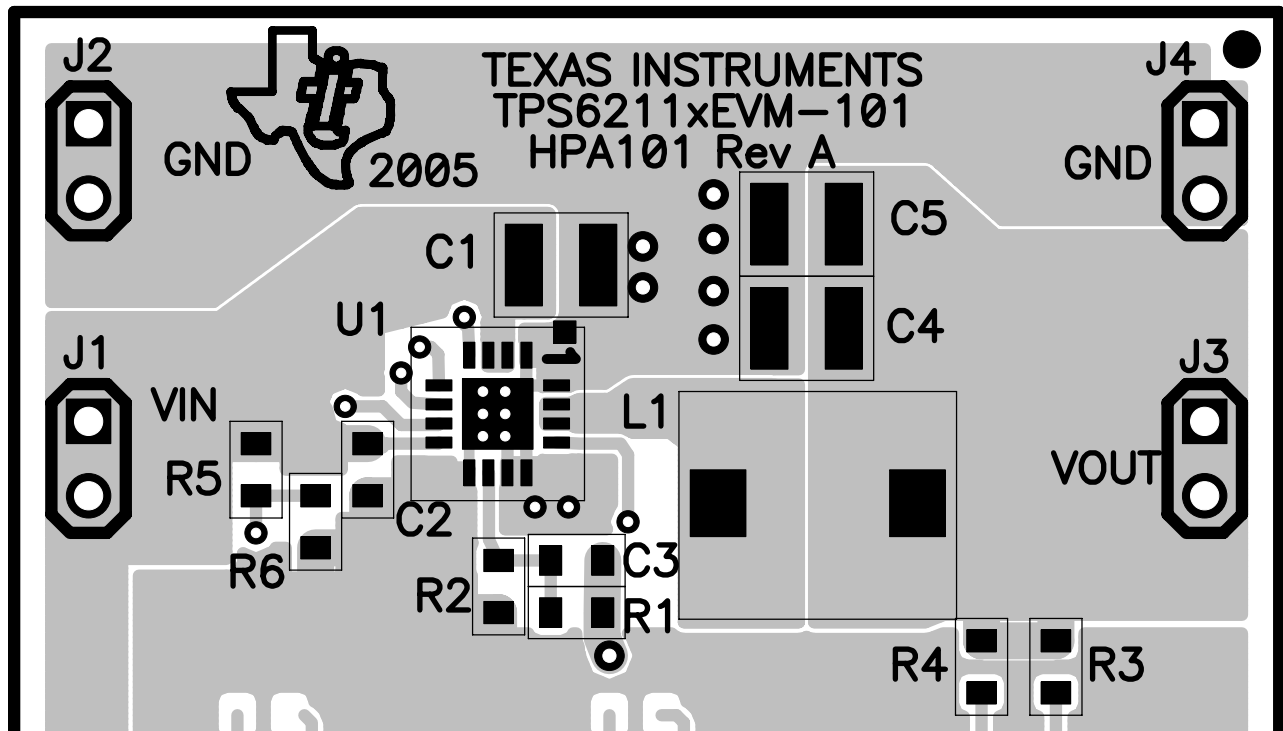
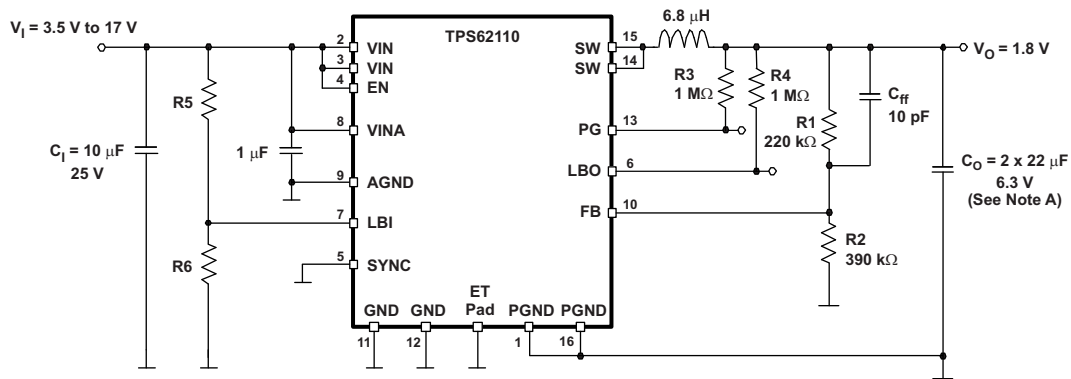

Figure 20. Recommended Layout

APPLICATION INFORMATION



- A. For an output voltage lower than 2.5 V, an output capacitor of 33 µF or greater is recommended to improve load transient performance.

Figure 21. Standard Connection for Adjustable Version

$$V_O = V_{FB} \times \frac{R1+R2}{R2} \quad R1 = R2 \times \left(\frac{V_O}{V_{FB}} \right) - R2$$

(7)

$V_{FB} = 1.153 \text{ V}$

Table 4. Recommended Resistors

OUTPUT VOLTAGE	R1	R2	NOMINAL VOLTAGE	TYPICAL C _{ff}
9 V	680 kΩ	100 kΩ	8.993 V	22 pF
5 V	510 kΩ	150 kΩ	5.073 V	10 pF
3.3 V	560 kΩ	300 kΩ	3.305 V	10 pF
2.5 V	390 kΩ	330 kΩ	2.515 V	10 pF
1.8 V	220 kΩ	390 kΩ	1.803 V	10 pF
1.5 V	100 kΩ	330 kΩ	1.502 V	10 pF

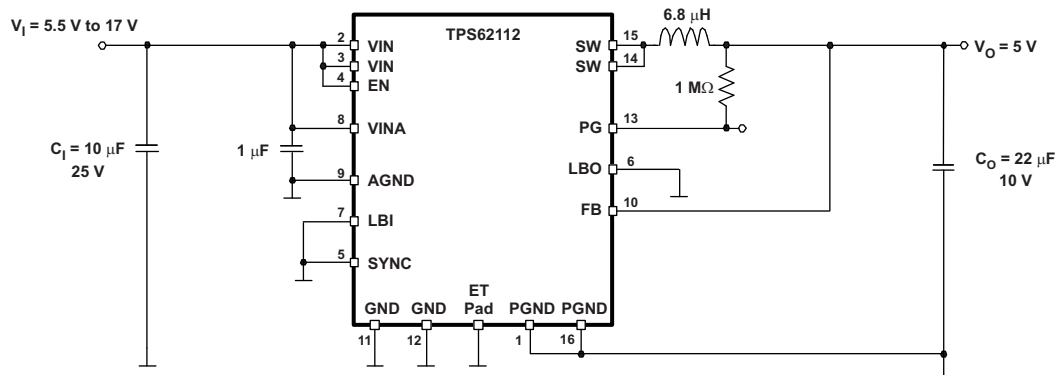
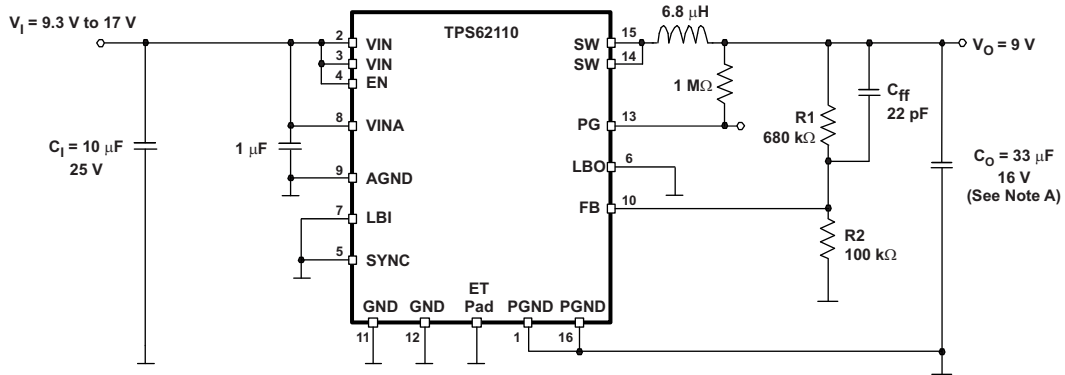

Figure 22. Standard Connection for Fixed-Voltage Version



- A. For an output voltage greater than 5 V, an output capacitor of 33 μF minimum is required for stability.

Figure 23. Application With 9-V Output

PACKAGING INFORMATION

Orderable Device	Status (1)	Package Type	Package Drawing	Pins	Package Qty	Eco Plan (2)	Lead/Ball Finish	MSL Peak Temp (3)	Samples (Requires Login)
TPS62110RSAR	ACTIVE	QFN	RSA	16	3000	Green (RoHS & no Sb/Br)	CU NIPDAU	Level-2-260C-1 YEAR	
TPS62110RSARG4	ACTIVE	QFN	RSA	16	3000	Green (RoHS & no Sb/Br)	CU NIPDAU	Level-2-260C-1 YEAR	
TPS62110RSAT	ACTIVE	QFN	RSA	16	250	Green (RoHS & no Sb/Br)	CU NIPDAU	Level-2-260C-1 YEAR	
TPS62110RSATG4	ACTIVE	QFN	RSA	16	250	Green (RoHS & no Sb/Br)	CU NIPDAU	Level-2-260C-1 YEAR	
TPS62111RSAR	ACTIVE	QFN	RSA	16	3000	Green (RoHS & no Sb/Br)	CU NIPDAU	Level-2-260C-1 YEAR	
TPS62111RSARG4	ACTIVE	QFN	RSA	16	3000	Green (RoHS & no Sb/Br)	CU NIPDAU	Level-2-260C-1 YEAR	
TPS62111RSAT	ACTIVE	QFN	RSA	16	250	Green (RoHS & no Sb/Br)	CU NIPDAU	Level-2-260C-1 YEAR	
TPS62111RSATG4	ACTIVE	QFN	RSA	16	250	Green (RoHS & no Sb/Br)	CU NIPDAU	Level-2-260C-1 YEAR	
TPS62112RSAR	ACTIVE	QFN	RSA	16	3000	Green (RoHS & no Sb/Br)	CU NIPDAU	Level-2-260C-1 YEAR	
TPS62112RSARG4	ACTIVE	QFN	RSA	16	3000	Green (RoHS & no Sb/Br)	CU NIPDAU	Level-2-260C-1 YEAR	
TPS62112RSAT	ACTIVE	QFN	RSA	16	250	Green (RoHS & no Sb/Br)	CU NIPDAU	Level-2-260C-1 YEAR	
TPS62112RSATG4	ACTIVE	QFN	RSA	16	250	Green (RoHS & no Sb/Br)	CU NIPDAU	Level-2-260C-1 YEAR	
TPS62113RSAR	ACTIVE	QFN	RSA	16	3000	Green (RoHS & no Sb/Br)	CU NIPDAU	Level-2-260C-1 YEAR	
TPS62113RSAT	ACTIVE	QFN	RSA	16	250	Green (RoHS & no Sb/Br)	CU NIPDAU	Level-2-260C-1 YEAR	

(1) The marketing status values are defined as follows:

ACTIVE: Product device recommended for new designs.

LIFEBUY: TI has announced that the device will be discontinued, and a lifetime-buy period is in effect.

NRND: Not recommended for new designs. Device is in production to support existing customers, but TI does not recommend using this part in a new design.

PREVIEW: Device has been announced but is not in production. Samples may or may not be available.

OBSOLETE: TI has discontinued the production of the device.

(2) Eco Plan - The planned eco-friendly classification: Pb-Free (RoHS), Pb-Free (RoHS Exempt), or Green (RoHS & no Sb/Br) - please check <http://www.ti.com/productcontent> for the latest availability information and additional product content details.

TBD: The Pb-Free/Green conversion plan has not been defined.

Pb-Free (RoHS): TI's terms "Lead-Free" or "Pb-Free" mean semiconductor products that are compatible with the current RoHS requirements for all 6 substances, including the requirement that lead not exceed 0.1% by weight in homogeneous materials. Where designed to be soldered at high temperatures, TI Pb-Free products are suitable for use in specified lead-free processes.

Pb-Free (RoHS Exempt): This component has a RoHS exemption for either 1) lead-based flip-chip solder bumps used between the die and package, or 2) lead-based die adhesive used between the die and leadframe. The component is otherwise considered Pb-Free (RoHS compatible) as defined above.

Green (RoHS & no Sb/Br): TI defines "Green" to mean Pb-Free (RoHS compatible), and free of Bromine (Br) and Antimony (Sb) based flame retardants (Br or Sb do not exceed 0.1% by weight in homogeneous material)

(3) MSL, Peak Temp. -- The Moisture Sensitivity Level rating according to the JEDEC industry standard classifications, and peak solder temperature.

Important Information and Disclaimer: The information provided on this page represents TI's knowledge and belief as of the date that it is provided. TI bases its knowledge and belief on information provided by third parties, and makes no representation or warranty as to the accuracy of such information. Efforts are underway to better integrate information from third parties. TI has taken and continues to take reasonable steps to provide representative and accurate information but may not have conducted destructive testing or chemical analysis on incoming materials and chemicals. TI and TI suppliers consider certain information to be proprietary, and thus CAS numbers and other limited information may not be available for release.

In no event shall TI's liability arising out of such information exceed the total purchase price of the TI part(s) at issue in this document sold by TI to Customer on an annual basis.

OTHER QUALIFIED VERSIONS OF TPS62110, TPS62111, TPS62112 :

- Automotive: [TPS62110-Q1](#)
- Enhanced Product: [TPS62110-EP](#), [TPS62111-EP](#), [TPS62112-EP](#)

NOTE: Qualified Version Definitions:

- Automotive - Q100 devices qualified for high-reliability automotive applications targeting zero defects
- Enhanced Product - Supports Defense, Aerospace and Medical Applications

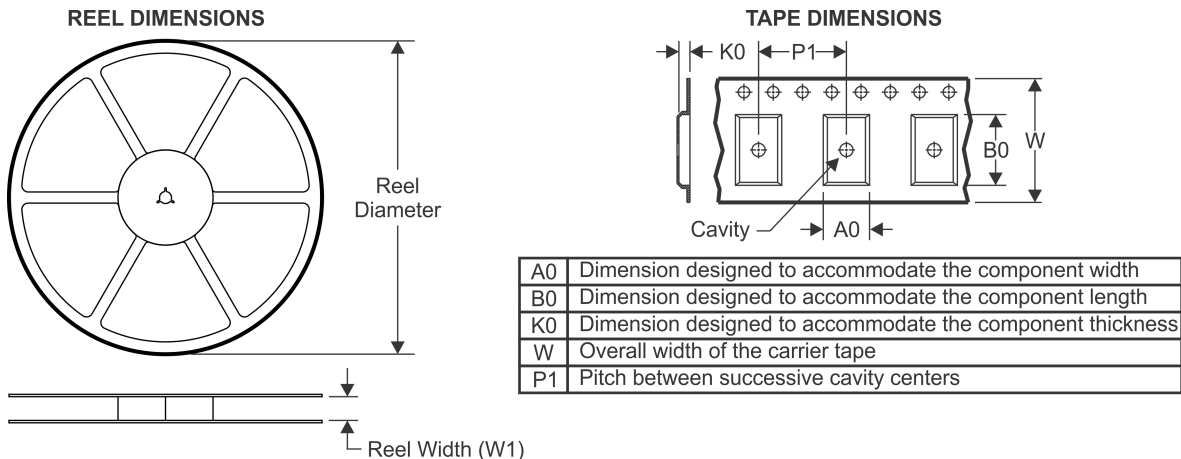
TAPE AND REEL INFORMATION

QUADRANT ASSIGNMENTS FOR PIN 1 ORIENTATION IN TAPE

*All dimensions are nominal

Device	Package Type	Package Drawing	Pins	SPQ	Reel Diameter (mm)	Reel Width W1 (mm)	A0 (mm)	B0 (mm)	K0 (mm)	P1 (mm)	W (mm)	Pin1 Quadrant
TPS62110RSAR	QFN	RSA	16	3000	330.0	12.4	4.25	4.25	1.15	8.0	12.0	Q2
TPS62110RSAT	QFN	RSA	16	250	180.0	12.4	4.25	4.25	1.15	8.0	12.0	Q2
TPS62111RSAR	QFN	RSA	16	3000	330.0	12.4	4.25	4.25	1.15	8.0	12.0	Q2
TPS62111RSAT	QFN	RSA	16	250	180.0	12.4	4.25	4.25	1.15	8.0	12.0	Q2
TPS62112RSAR	QFN	RSA	16	3000	330.0	12.4	4.25	4.25	1.15	8.0	12.0	Q2
TPS62112RSAR	QFN	RSA	16	3000	330.0	12.4	4.25	4.25	1.15	8.0	12.0	Q2
TPS62112RSAT	QFN	RSA	16	250	180.0	12.4	4.25	4.25	1.15	8.0	12.0	Q2
TPS62113RSAR	QFN	RSA	16	3000	330.0	12.4	4.25	4.25	1.15	8.0	12.0	Q2
TPS62113RSAR	QFN	RSA	16	3000	330.0	12.4	4.25	4.25	1.15	8.0	12.0	Q2
TPS62113RSAT	QFN	RSA	16	250	180.0	12.4	4.25	4.25	1.15	8.0	12.0	Q2
TPS62113RSAT	QFN	RSA	16	250	180.0	12.4	4.25	4.25	1.15	8.0	12.0	Q2

TAPE AND REEL BOX DIMENSIONS

*All dimensions are nominal

Device	Package Type	Package Drawing	Pins	SPQ	Length (mm)	Width (mm)	Height (mm)
TPS62110RSAR	QFN	RSA	16	3000	367.0	367.0	35.0
TPS62110RSAT	QFN	RSA	16	250	210.0	185.0	35.0
TPS62111RSAR	QFN	RSA	16	3000	367.0	367.0	35.0
TPS62111RSAT	QFN	RSA	16	250	210.0	185.0	35.0
TPS62112RSAR	QFN	RSA	16	3000	367.0	367.0	35.0
TPS62112RSAR	QFN	RSA	16	3000	367.0	367.0	35.0
TPS62112RSAT	QFN	RSA	16	250	210.0	185.0	35.0
TPS62113RSAR	QFN	RSA	16	3000	367.0	367.0	35.0
TPS62113RSAR	QFN	RSA	16	3000	367.0	367.0	35.0
TPS62113RSAT	QFN	RSA	16	250	210.0	185.0	35.0
TPS62113RSAT	QFN	RSA	16	250	210.0	185.0	35.0

RSA (S-PVQFN-N16)

PLASTIC QUAD FLATPACK NO-LEAD

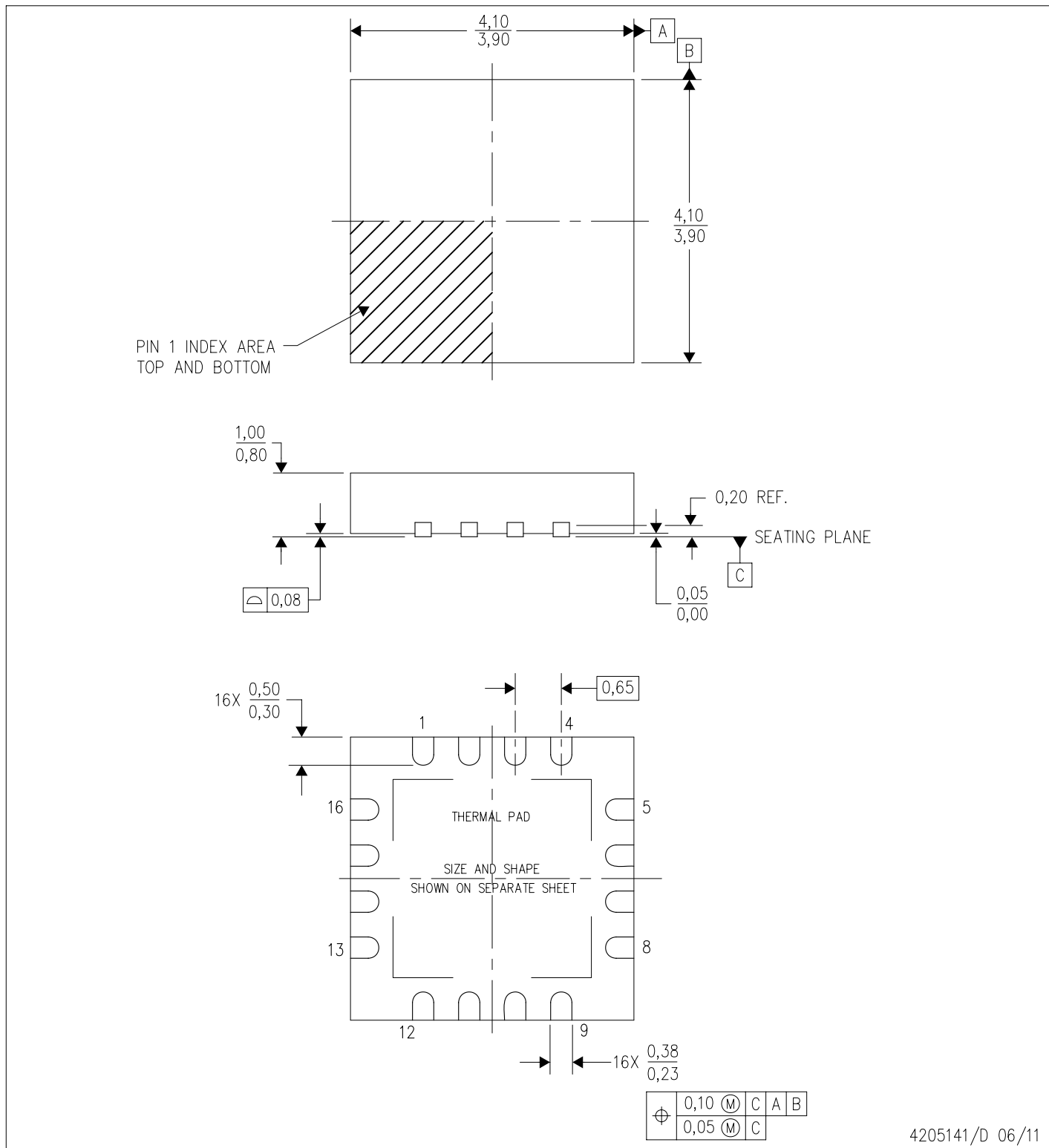

- NOTES:
- All linear dimensions are in millimeters. Dimensioning and tolerancing per ASME Y14.5M-1994.
 - This drawing is subject to change without notice.
 - Quad Flatpack, No-leads (QFN) package configuration.
 - The package thermal pad must be soldered to the board for thermal and mechanical performance.
 - See the additional figure in the Product Data Sheet for details regarding the exposed thermal pad features and dimensions.
 - Falls within JEDEC MO-220.

THERMAL PAD MECHANICAL DATA

RSA (S-PVQFN-N16)

PLASTIC QUAD FLATPACK NO-LEAD

THERMAL INFORMATION

This package incorporates an exposed thermal pad that is designed to be attached directly to an external heatsink. The thermal pad must be soldered directly to the printed circuit board (PCB). After soldering, the PCB can be used as a heatsink. In addition, through the use of thermal vias, the thermal pad can be attached directly to the appropriate copper plane shown in the electrical schematic for the device, or alternatively, can be attached to a special heatsink structure designed into the PCB. This design optimizes the heat transfer from the integrated circuit (IC).

For information on the Quad Flatpack No-Lead (QFN) package and its advantages, refer to Application Report, QFN/SON PCB Attachment, Texas Instruments Literature No. SLUA271. This document is available at www.ti.com.

The exposed thermal pad dimensions for this package are shown in the following illustration.

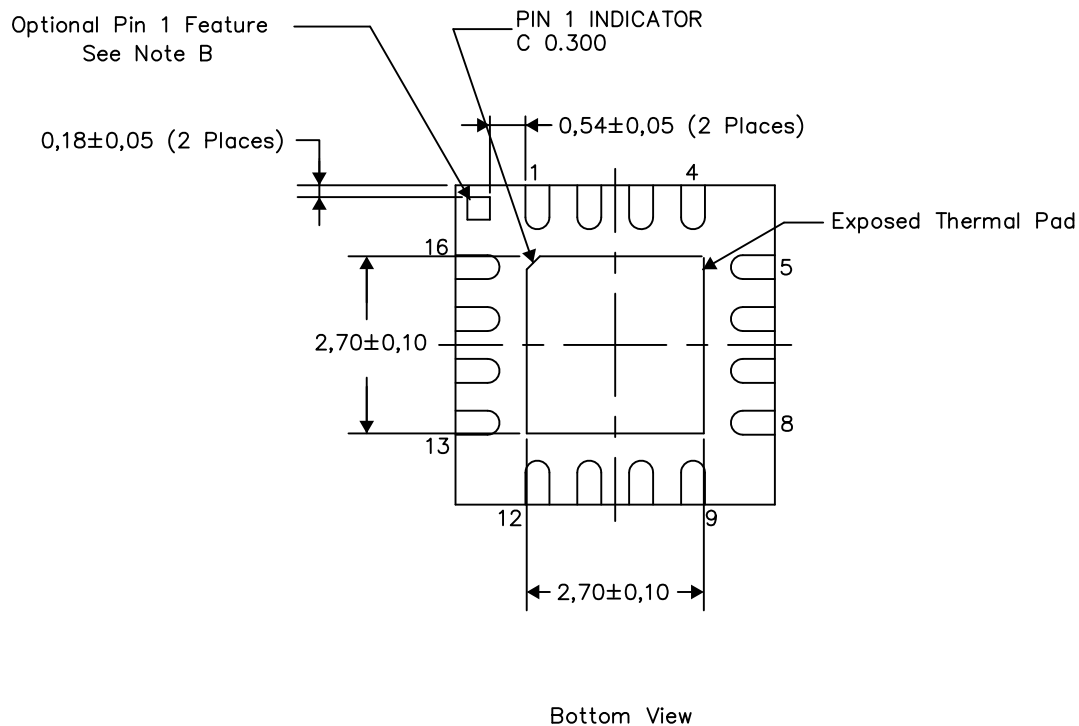

Exposed Thermal Pad Dimensions

4206364/L 08/12

NOTES:

- A. All linear dimensions are in millimeters
- B. The Pin 1 Identification mark is an optional feature that may be present on some devices
In addition, this Pin 1 feature if present is electrically connected to the center thermal pad and therefore should be considered when routing the board layout.

RSA (S-PVQFN-N16)

PLASTIC QUAD FLATPACK NO-LEAD

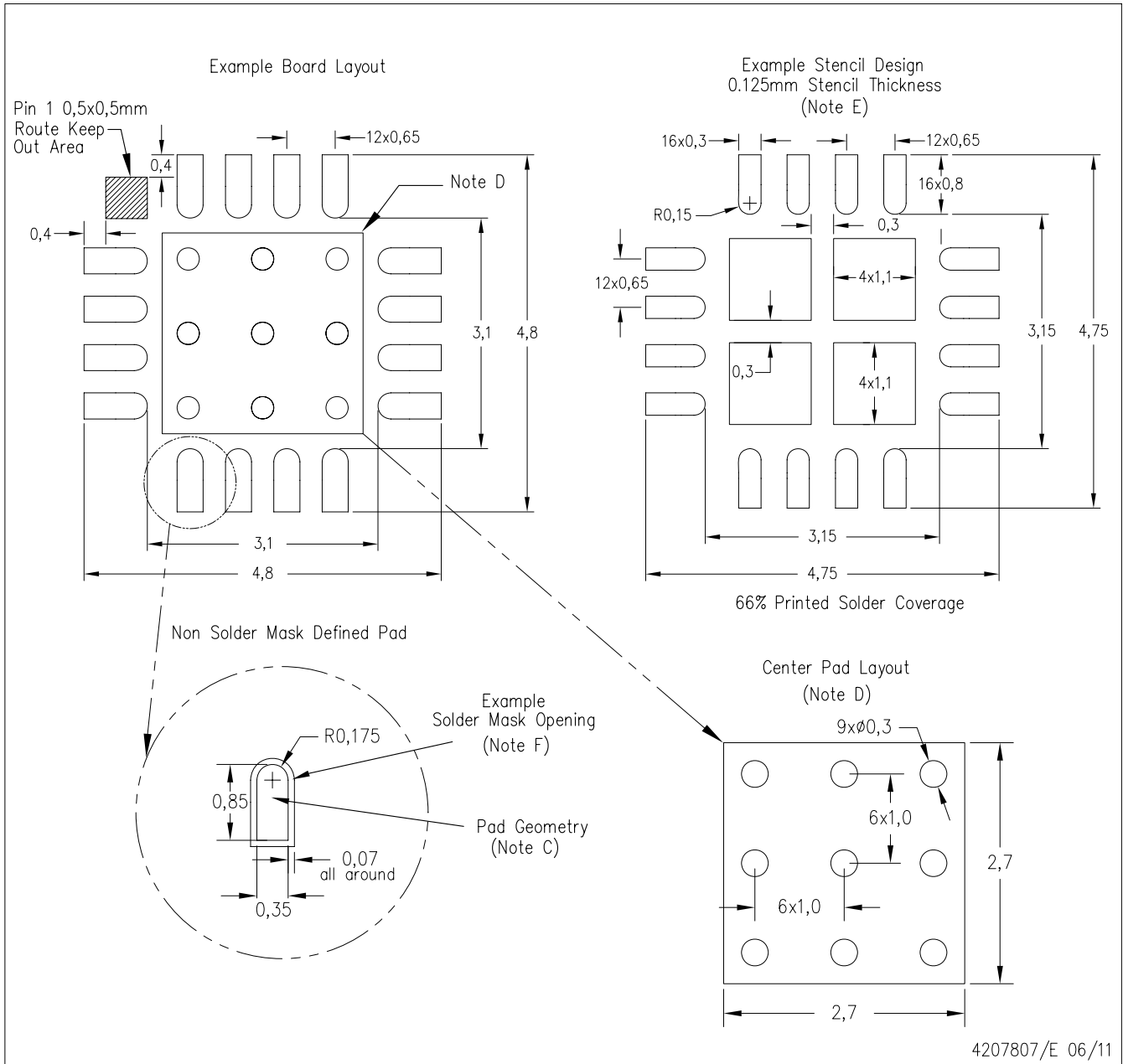

- NOTES:
- All linear dimensions are in millimeters.
 - This drawing is subject to change without notice.
 - Publication IPC-7351 is recommended for alternate designs.
 - This package is designed to be soldered to a thermal pad on the board. Refer to Application Note, QFN Packages, Texas Instruments Literature No. SLUA271, and also the Product Data Sheets for specific thermal information, via requirements, and recommended board layout. These documents are available at www.ti.com <<http://www.ti.com>>.
 - Laser cutting apertures with trapezoidal walls and also rounding corners will offer better paste release. Customers should contact their board assembly site for stencil design recommendations. Refer to IPC 7525 for stencil design considerations.
 - Customers should contact their board fabrication site for solder mask tolerances.

IMPORTANT NOTICE

Texas Instruments Incorporated and its subsidiaries (TI) reserve the right to make corrections, enhancements, improvements and other changes to its semiconductor products and services per JESD46, latest issue, and to discontinue any product or service per JESD48, latest issue. Buyers should obtain the latest relevant information before placing orders and should verify that such information is current and complete. All semiconductor products (also referred to herein as "components") are sold subject to TI's terms and conditions of sale supplied at the time of order acknowledgment.

TI warrants performance of its components to the specifications applicable at the time of sale, in accordance with the warranty in TI's terms and conditions of sale of semiconductor products. Testing and other quality control techniques are used to the extent TI deems necessary to support this warranty. Except where mandated by applicable law, testing of all parameters of each component is not necessarily performed.

TI assumes no liability for applications assistance or the design of Buyers' products. Buyers are responsible for their products and applications using TI components. To minimize the risks associated with Buyers' products and applications, Buyers should provide adequate design and operating safeguards.

TI does not warrant or represent that any license, either express or implied, is granted under any patent right, copyright, mask work right, or other intellectual property right relating to any combination, machine, or process in which TI components or services are used. Information published by TI regarding third-party products or services does not constitute a license to use such products or services or a warranty or endorsement thereof. Use of such information may require a license from a third party under the patents or other intellectual property of the third party, or a license from TI under the patents or other intellectual property of TI.

Reproduction of significant portions of TI information in TI data books or data sheets is permissible only if reproduction is without alteration and is accompanied by all associated warranties, conditions, limitations, and notices. TI is not responsible or liable for such altered documentation. Information of third parties may be subject to additional restrictions.

Resale of TI components or services with statements different from or beyond the parameters stated by TI for that component or service voids all express and any implied warranties for the associated TI component or service and is an unfair and deceptive business practice. TI is not responsible or liable for any such statements.

Buyer acknowledges and agrees that it is solely responsible for compliance with all legal, regulatory and safety-related requirements concerning its products, and any use of TI components in its applications, notwithstanding any applications-related information or support that may be provided by TI. Buyer represents and agrees that it has all the necessary expertise to create and implement safeguards which anticipate dangerous consequences of failures, monitor failures and their consequences, lessen the likelihood of failures that might cause harm and take appropriate remedial actions. Buyer will fully indemnify TI and its representatives against any damages arising out of the use of any TI components in safety-critical applications.

In some cases, TI components may be promoted specifically to facilitate safety-related applications. With such components, TI's goal is to help enable customers to design and create their own end-product solutions that meet applicable functional safety standards and requirements. Nonetheless, such components are subject to these terms.

No TI components are authorized for use in FDA Class III (or similar life-critical medical equipment) unless authorized officers of the parties have executed a special agreement specifically governing such use.

Only those TI components which TI has specifically designated as military grade or "enhanced plastic" are designed and intended for use in military/aerospace applications or environments. Buyer acknowledges and agrees that any military or aerospace use of TI components which have **not** been so designated is solely at the Buyer's risk, and that Buyer is solely responsible for compliance with all legal and regulatory requirements in connection with such use.

TI has specifically designated certain components which meet ISO/TS16949 requirements, mainly for automotive use. Components which have not been so designated are neither designed nor intended for automotive use; and TI will not be responsible for any failure of such components to meet such requirements.

Products

Audio	www.ti.com/audio
Amplifiers	amplifier.ti.com
Data Converters	dataconverter.ti.com
DLP® Products	www.dlp.com
DSP	dsp.ti.com
Clocks and Timers	www.ti.com/clocks
Interface	interface.ti.com
Logic	logic.ti.com
Power Mgmt	power.ti.com
Microcontrollers	microcontroller.ti.com
RFID	www.ti-rfid.com
OMAP Applications Processors	www.ti.com/omap
Wireless Connectivity	www.ti.com/wirelessconnectivity

Applications

Automotive and Transportation	www.ti.com/automotive
Communications and Telecom	www.ti.com/communications
Computers and Peripherals	www.ti.com/computers
Consumer Electronics	www.ti.com/consumer-apps
Energy and Lighting	www.ti.com/energy
Industrial	www.ti.com/industrial
Medical	www.ti.com/medical
Security	www.ti.com/security
Space, Avionics and Defense	www.ti.com/space-avionics-defense
Video and Imaging	www.ti.com/video

TI E2E Community

e2e.ti.com