

## HIGH-EFFICIENCY STEP-DOWN LOW POWER DC-DC CONVERTER

### FEATURES

- High-Efficiency Synchronous Step-Down Converter With Greater Than 95% Efficiency
- 2 V to 5.5 V Operating Input Voltage Range
- Adjustable Output Voltage Range From 0.8 V to  $V_I$
- Fixed Output Voltage Options Available in 0.9 V, 1 V, 1.2 V, 1.5 V, 1.8 V, 1.9 V, 2.5 V, and 3.3 V
- Synchronizable to External Clock Signal up to 1 MHz
- Up to 600 mA Output Current
- Pin-Programmable Current Limit
- High Efficiency Over a Wide Load Current Range in Power Save Mode
- 100% Maximum Duty Cycle for Lowest Dropout

- Low-Noise Operation Antiringing Switch and PFM/PWM Operation Mode
- Internal Softstart
- 50- $\mu$ A Quiescent Current (TYP)
- Available in the 10-Pin Microsmall Outline Package (MSOP)
- Evaluation Module Available

### APPLICATIONS

- Low-Power CPUs and DSPs
- Cellular Phones
- Organizers, PDAs, and Handheld PCs
- MP-3 Portable Audio Players
- Digital Cameras
- USB-Based DSL Modems and Other Network Interface Cards

### DESCRIPTION

The TPS6200x devices are a family of low-noise synchronous step-down dc-dc converters that are ideally suited for systems powered from a 1-cell Li-ion battery or from a 2- to 3-cell NiCd, NiMH, or alkaline battery. The TPS6200x operates typically down to an input voltage of 1.8 V, with a specified minimum input voltage of 2 V.

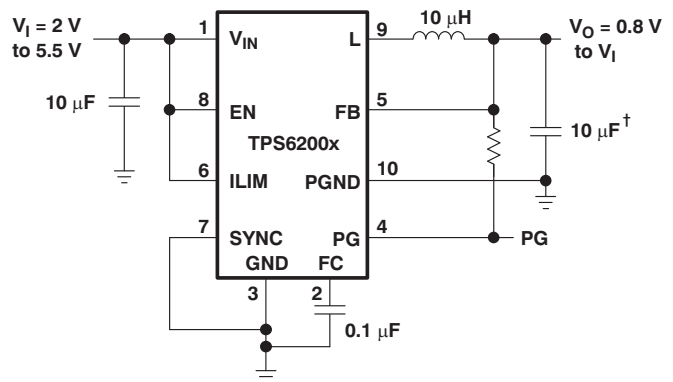
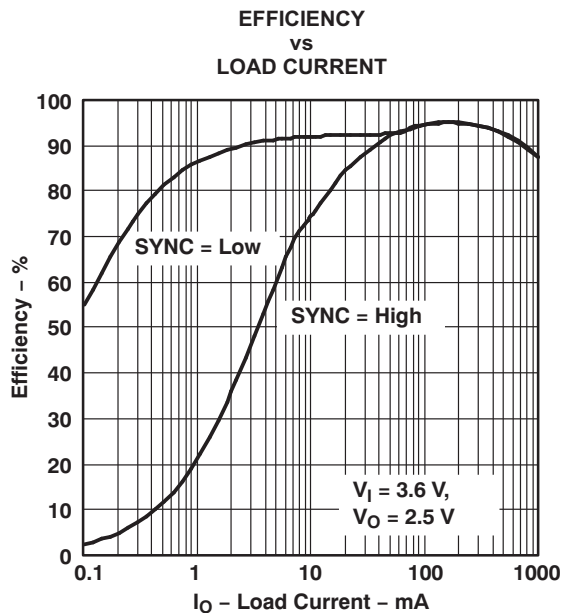

Figure 2. Typical Application Circuit for Fixed Output Voltage Option



Please be aware that an important notice concerning availability, standard warranty, and use in critical applications of Texas Instruments semiconductor products and disclaimers thereto appears at the end of this data sheet.

## DESCRIPTION (CONTINUED)

The TPS6200x is a synchronous current-mode PWM converter with integrated – and P-channel power MOSFET switches. Synchronous rectification is used to increase efficiency and to reduce external component count. To achieve the highest efficiency over a wide load current range, the converter enters a power-saving pulse-frequency modulation (PFM) mode at light load currents. Operating frequency is typically 750 kHz, allowing the use of small inductor and capacitor values. The device can be synchronized to an external clock signal in the range of 500 kHz to 1 MHz. For low-noise operation, the converter can be operated in the PWM mode and the internal antiringing switch reduces noise and EMI. In the shutdown mode, the current consumption is reduced to less than 1  $\mu$ A. The TPS62000 is available in the 10-pin (DGS) microsmall outline package (MSOP). The device operates over a free-air temperature range of  $-40^{\circ}\text{C}$  to  $85^{\circ}\text{C}$ .

MSOP (DGS) PACKAGE  
 (TOP VIEW)

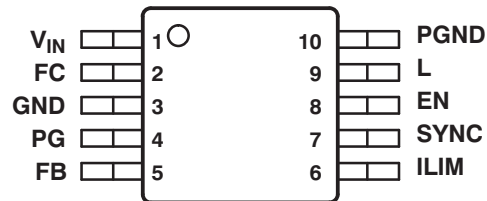

## AVAILABLE OPTIONS

T <sub>A</sub>	VOLTAGE OPTIONS	PACKAGE <sup>(1)</sup>	MARKING
		MSOP	DGS
$-40^{\circ}\text{C}$ to $85^{\circ}\text{C}$	Adjustable	TPS62000DGS	AIH
	0.9 V	TPS62001DGS	AIL
	1 V	TPS62002DGS	AIJ
	1.2 V	TPS62003DGS	AIK
	1.5 V	TPS62004DGS	AIL
	1.8 V	TPS62005DGS	AIM
	1.9 V	TPS62008DGS	AJI
	2.5 V	TPS62006DGS	AIN
	3.3 V	TPS62007DGS	AIO

(1) For shipment quantities and additional package information see the Package Option Addendum at the end of the data sheet.

### FUNCTIONAL BLOCK DIAGRAM

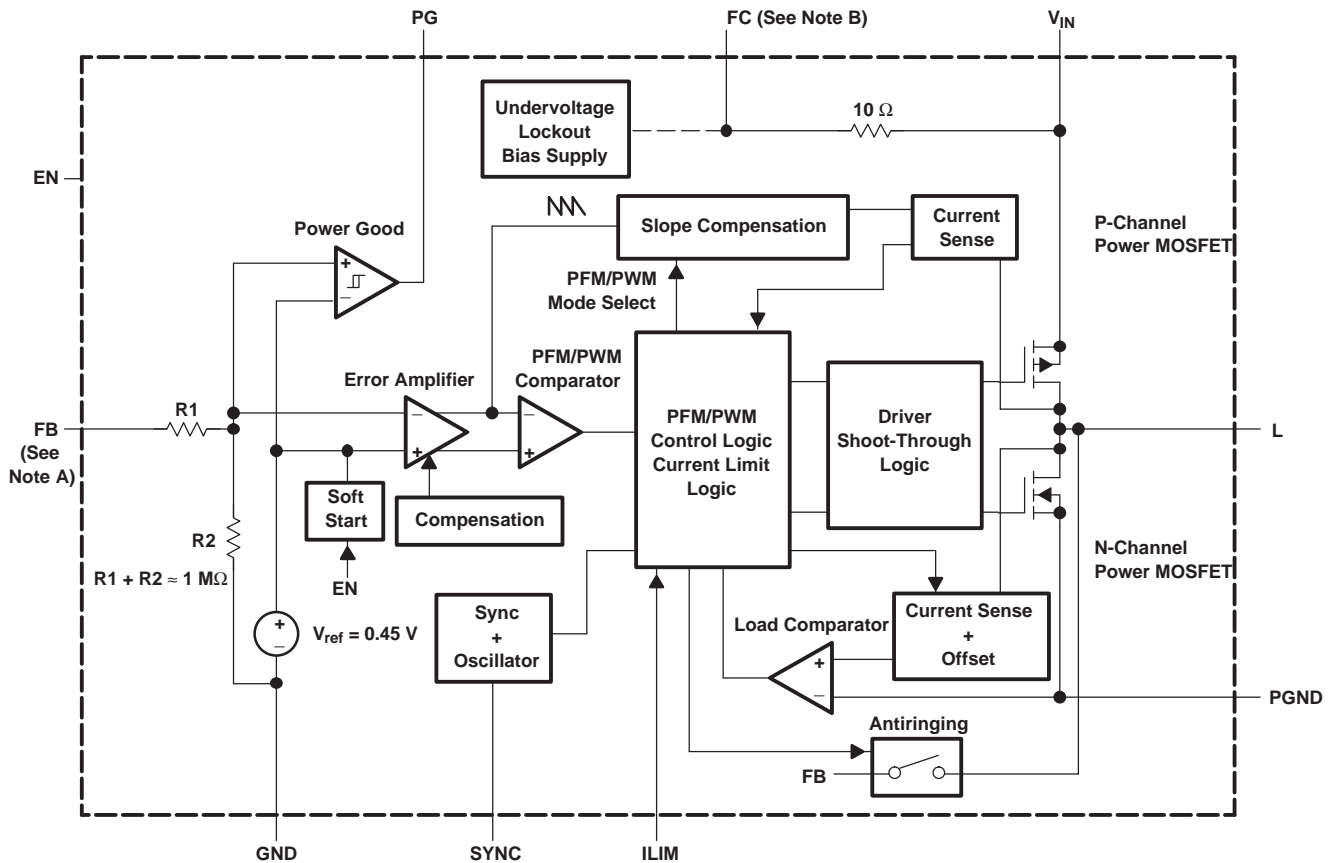

- A. The adjustable output voltage version does not use the internal feedback resistor divider. The FB pin is directly connected to the error amplifier.
- B. Do not connect the FC pin to an external power source

### PIN FUNCTIONS

PIN		I/O	DESCRIPTION
NAME	NO.		
EN	8	I	Enable. A logic high enables the converter, logic low forces the device into shutdown mode reducing the supply current to less than 1 $\mu$ A.
FB	5	I	Feedback pin for the fixed output voltage option. For the adjustable version an external resistive divider is connected to FB. The internal voltage divider is disabled for the adjustable version.
FC	2		Supply bypass pin. A 0.1 $\mu$ F coupling capacitor should be connected as close as possible to this pin for good high frequency input voltage supply filtering.
GND	3		Ground
ILIM	6	I	Switch current limit. Connect ILIM to GND to set the switch current limit to typically 600 mA, or connect this pin to $V_{IN}$ to set the current limit to typically 1200 mA.
L	9	I/O	Connect the inductor to this pin. L is the switch pin connected to the drain of the internal power MOSFETS.
PG	4	O	Power good comparator output. This is an open-drain output. A pullup resistor should be connected between PG and $V_O$ . The output goes active high when the output voltage is greater than 92% of the nominal value.
PGND	10		Power ground. Connect all power grounds to PGND.
SYNC	7	I	Input for synchronization to external clock signal. Synchronizes the converter switching frequency to an external clock signal with CMOS level: SYNC = HIGH: Low-noise mode enabled, fixed frequency PWM operation is forced SYNC = LOW (GND): Power save mode enabled, PFM/PWM mode enabled.
$V_{IN}$	1	I	Supply voltage input

## DETAILED DESCRIPTION

### Operation

The TPS6200x is a step down converter operating in a current mode PFM/PWM scheme with a typical switching frequency of 750 kHz.

At moderate to heavy loads, the converter operates in the pulse width modulation (PWM) and at light loads the converter enters a power save mode (pulse frequency modulation) to keep the efficiency high.

In the PWM mode operation, the part operates at a fixed frequency of 750 kHz. At the beginning of each clock cycle, the high side P-channel MOSFET is turned on. The current in the inductor ramps up and is sensed via an internal circuit. The high side switch is turned off when the sensed current causes the PFM/PWM comparator to trip when the output voltage is in regulation or when the inductor current reaches the current limit (set by ILIM). After a minimum dead time preventing shoot through current, the low side N-channel MOSFET is turned on and the current ramps down again. As the clock cycle is completed, the low side switch is turned off and the next clock cycle starts.

In discontinuous conduction mode (DCM), the inductor current ramps to zero before the end of each clock cycle. In order to increase the efficiency the load comparator turns off the low side MOSFET before the inductor current becomes negative. This prevents reverse current flowing from the output capacitor through the inductor and low side MOSFET to ground that would cause additional losses.

As the load current decreases and the peak inductor current does not reach the power save mode threshold of typically 120 mA for more than 15 clock cycles, the converter enters a pulse frequency modulation (PFM) mode.

In the PFM mode, the converter operates with:

- Variable frequency
- Constant peak current that reduces switching losses
- Quiescent current at a minimum

Thus maintaining the highest efficiency at light load currents. In this mode, the output voltage is monitored with the error amplifier. As soon as the output voltage falls below the nominal value, the high side switch is turned on and the inductor current ramps up. When the inductor current reaches the peak current of typical:  $150 \text{ mA} + 50 \text{ mA/V} \times (V_I - V_O)$ , the high side switch turns off and the low side switch turns on. As the inductor current ramps down, the low side switch is turned off before the inductor current becomes negative which completes the cycle. When the output voltage falls below the nominal voltage again, the next cycle is started.

The converter enters the PWM mode again as soon as the output voltage can not be maintained with the typical peak inductor current in the PFM mode.

The control loop is internally compensated reducing the amount of external components.

The switch current is internally sensed and the maximum current limit can be set to typical 600 mA by connecting ILIM to ground; or, to typically 1.2 A by connecting ILIM to  $V_{IN}$ .

### 100% Duty Cycle Operation

As the input voltage approaches the output voltage and the duty cycle exceeds typical 95%, the converter turns the P-channel high side switch continuously on. In this mode, the output voltage is equal to the input voltage minus the voltage drop across the P-channel MOSFET.

### Synchronization, Power Save Mode and Forced PWM Mode

If no clock signal is applied, the converter operates with a typical switching frequency of 750 kHz. It is possible to synchronize the converter to an external clock within a frequency range from 500 kHz to 1000 kHz. The device automatically detects the rising edge of the first clock and is synchronizes immediately to the external clock. If the clock signal is stopped, the converter automatically switches back to the internal clock and continues operation without interruption. The switch over is initiated if no rising edge on the SYNC pin is detected for a duration of four clock cycles. Therefore, the maximum delay time can be 8  $\mu\text{s}$  in case the internal clock has a minimum frequency of 500 kHz.

In case the device is synchronized to an external clock, the power save mode is disabled and the device stays in forced PWM mode.

Connecting the SYNC pin to the GND pin enables the power save mode. The converter operates in the PWM mode at moderate to heavy loads and in the PFM mode during light loads maintaining high efficiency over a wide load current range.

Connecting the SYNC pin to the  $V_{IN}$  pin forces the converter to operate permanently in the PWM mode even at light or no load currents. The advantage is the converter operates with a fixed switching frequency that allows simple filtering of the switching frequency for noise sensitive applications. In this mode, the efficiency is lower compared to the power save mode during light loads (see [Figure 1](#)).

It is possible to switch from forced PWM mode to the power save mode during operation.

The flexible configuration of the SYNC pin during operation of the device allows efficient power management by adjusting the operation of the TPS6200x to the specific system requirements.

### Low Noise Antiringing Switch

An *antiringing* switch is implemented in order to reduce the EMI radiated from the converter during discontinuous conduction mode (DCM). In DCM, the inductor current ramps to zero before the end of each switching period. The internal load comparator turns off the low side switch at that instant thus preventing the current flowing backward through the inductance which increases the efficiency. An antiringing switch across the inductor prevents parasitic oscillation caused by the residual energy stored in the inductance (see [Figure 12](#)).

#### NOTE:

The *antiringing* switch is only activated in the fixed output voltage versions. It is not enabled for the adjustable output voltage version TPS62000.

### Soft Start

As the enable pin (EN) goes high, the soft-start function generates an internal voltage ramp. This causes the start-up current to slowly rise preventing output voltage overshoot and high inrush currents. The soft-start duration is typical 1 ms (see [Figure 13](#)). When the soft-start function is completed, the error amplifier is connected directly to the internal voltage reference.

### Enable

Logic low on EN forces the TPS6200x into shutdown. In shutdown, the power switch, drivers, voltage reference, oscillator, and all other functions are turned off. The supply current is reduced to less than 1  $\mu$ A in the shutdown mode.

### Undervoltage Lockout

An undervoltage lockout circuit provides the save operation of the device. It prevents the converter from turning on when the voltage on  $V_{IN}$  is less than typically 1.6 V.

### Power Good Comparator

The power good (PG) comparator has an open drain output capable of sinking typically 10  $\mu$ A. The PG is only active when the device is enabled (EN = high). When the device is disabled (EN = low), the PG pin is high impedance.

The PG output is only valid after a 100  $\mu$ s delay after the device is enabled and the supply voltage is greater than 1.2 V. This is only important in cases where the pullup resistor of the PG pin is connected to an external voltage source which might cause an initial spike (false high signal) within the first 100  $\mu$ s after the input voltage exceeds 1.2 V. This initial spike can be filtered with a small R-C filter to avoid false power good signals during start-up.

If the PG pin is connected to the output of the TPS62000 with a pullup resistor, no initial spike (false high signal) occurs and no precautions have to be taken during start-up.

The PG pin becomes active high when the output voltage exceeds typically 94.5% of its nominal value. Leave the PG pin unconnected when not used.

## No Load Operation

In case the converter operates in the forced PWM mode and there is no load connected to the output, the converter will regulate the output voltage by allowing the inductor current to reverse for a short period of time.

## ABSOLUTE MAXIMUM RATINGS

over operating free-air temperature range (unless otherwise noted)<sup>(1)</sup>

	VALUE	UNIT
Supply voltages on pin VIN and FC <sup>(2)</sup>	–0.3 to 6	V
Voltages on pins EN, ILIM, SYNC, PG, FB, L <sup>(2)</sup>	–0.3 to V <sub>IN</sub> + 0.3	V
Peak switch current	1.6	A
Continuous power dissipation	See Dissipation Rating Table	
T <sub>J</sub> Operating junction temperature range	–40 to 150	°C
T <sub>stg</sub> Storage temperature range	–65 to 150	°C
Lead temperature (soldering, 10 sec)	260	°C

- (1) Stresses beyond those listed under *absolute maximum ratings* may cause permanent damage to the device. These are stress ratings only, and functional operation of the device at these or any other conditions beyond those indicated under *recommended operating conditions* is not implied. Exposure to absolute-maximum-rated conditions for extended periods may affect device reliability.
- (2) All voltage values are with respect to network ground terminal.

## DISSIPATION RATINGS

PACKAGE <sup>(1)</sup>	T <sub>A</sub> ≤ 25°C POWER RATING	DERATING FACTOR T <sub>A</sub> = 25°C	T <sub>A</sub> = 70°C POWER RATING	T <sub>A</sub> = 85°C POWER RATING
10 pin MSOP	555 mW	5.56 mW/°C	305 mW	221 mW

- (1) The thermal resistance junction to ambient of the 10-pin MSOP is 180°C/W. The device will not run into thermal limitations provided it is operated within the specified range.

## RECOMMENDED OPERATING CONDITIONS

over operating free-air temperature range (unless otherwise noted)

	MIN	TYP	MAX	UNIT
V <sub>I</sub> Supply voltage	2		5.5	V
V <sub>O</sub> Output voltage range for adjustable output voltage version	0.8		V <sub>I</sub>	V
I <sub>O</sub> Output current for 3-cell operation (V <sub>I</sub> ≥ 2.5 V; L = 10 μH, f = 750 kHz)			600	mA
I <sub>O</sub> Output current for 2-cell operation (V <sub>I</sub> ≥ 2 V; L = 10 μH, f = 750 kHz)			200	mA
L Inductor <sup>(1)</sup> (see Note 2)		10		μH
C <sub>I</sub> Input capacitor <sup>(1)</sup>	10			μF
C <sub>O</sub> Output capacitor <sup>(1)</sup> (V <sub>O</sub> ≥ 1.8 V)	10			μF
C <sub>O</sub> Output capacitor <sup>(1)</sup> V <sub>O</sub> < 1.8 V)	47			μF
T <sub>A</sub> Operating ambient temperature	–40		85	°C
T <sub>J</sub> Operating junction temperature	–40		125	°C

- (1) Refer to application section for further information.

## ELECTRICAL CHARACTERISTICS

over recommended operating free-air temperature range,  $V_I = 3.6\text{ V}$ ,  $V_O = 2.5\text{ V}$ ,  $I_O = 300\text{ mA}$ ,  $EN = V_{IN}$ ,  $ILIM = V_{IN}$ ,  $T_A = -40^\circ\text{C}$  to  $85^\circ\text{C}$  (unless otherwise noted)

PARAMETER		TEST CONDITIONS	MIN	TYP	MAX	UNIT	
<b>SUPPLY CURRENT</b>							
$V_I$	Input voltage range	$I_O = 0\text{ mA to }600\text{ mA}$	2.5		5.5	V	
		$I_O = 0\text{ mA to }200\text{ mA}$	2		5.5		
$I_{(Q)}$	Operating quiescent current	$I_O = 0\text{ mA}$ , SYNC = GND (PFM-mode enabled)		50	75	$\mu\text{A}$	
$I_{(SD)}$	Shutdown current	EN = GND		0.1	1	$\mu\text{A}$	
<b>ENABLE</b>							
$V_{IH}$	EN high-level input voltage		1.3			V	
$V_{IL}$	EN low level input voltage				0.4	V	
$I_{lkg}$	EN input leakage current	EN = GND or $V_{IN}$		0.01	0.1	$\mu\text{A}$	
$V_{(UVLO)}$	Undervoltage lockout threshold		1.2	1.6	1.95	V	
<b>POWER SWITCH AND CURRENT LIMIT</b>							
$r_{DS(on)}$	P-channel MOSFET on-resistance	$V_I = V_{GS} = 3.6\text{ V}$ , $I = 200\text{ mA}$	200	280	410	m $\Omega$	
		$V_I = V_{GS} = 2\text{ V}$ , $I = 200\text{ mA}$		480			
	P-channel leakage current	$V_{DS} = 5.5\text{ V}$				1	$\mu\text{A}$
	N-channel MOSFET on-resistance		$V_I = V_{GS} = 3.6\text{ V}$ , $I_O = 200\text{ mA}$	200	280	410	m $\Omega$
$V_I = V_{GS} = 2\text{ V}$ , $I_O = 200\text{ mA}$				500			
	N-channel leakage current	$V_{DS} = 5.5\text{ V}$			1	$\mu\text{A}$	
$I_{(LIM)}$	P-channel current limit	$2.5\text{ V} \leq V_I \leq 5.5\text{ V}$ , ILIM = $V_{IN}$	800	1200	1600	mA	
		$2\text{ V} \leq V_I \leq 5.5\text{ V}$ , ILIM = GND	390	600	900		
$V_{IH}$	ILIM high-level input voltage		1.3			V	
$V_{IL}$	ILIM low-level input voltage				0.4	V	
$I_{lkg}$	ILIM input leakage current	ILIM = GND or $V_{IN}$		0.01	0.1	$\mu\text{A}$	
<b>POWER GOOD OUTPUT (see <sup>(1)</sup>)</b>							
$V_{(PG)}$	Power good threshold	Feedback voltage falling	88% $V_O$	92% $V_O$	94% $V_O$	V	
	Power good hysteresis			2.5% $V_O$		V	
$V_{OL}$	PG output low voltage	$V_{(FB)} = 0.8 \times V_O$ nominal, $I_{(sink)} = 10\text{ }\mu\text{A}$			0.3	V	
$I_{lkg}$	PG output leakage current	$V_{(FB)} = V_O$ nominal		0.01	1	$\mu\text{A}$	
	Minimum supply voltage for valid power good signal		1.2			V	
<b>OSCILLATOR</b>							
$f_s$	Oscillator frequency		500	750	1000	kHz	
$f_{(SYNC)}$	Synchronization range	CMOS-logic clock signal on SYNC pin	500		1000	kHz	
$V_{IH}$	SYNC high level input voltage		1.3			V	
$V_{IL}$	SYNC low level input voltage				0.4	V	
$I_{lkg}$	SYNC input leakage current	SYNC = GND or $V_{IN}$		0.01	0.1	$\mu\text{A}$	
	Duty cycle of external clock signal		20%		60%		

(1) Power good is not valid for the first 100  $\mu\text{s}$  after EN goes high. Refer to the application section for more information.

## ELECTRICAL CHARACTERISTICS

over recommended operating free-air temperature range,  $V_I = 3.6\text{ V}$ ,  $V_O = 2.5\text{ V}$ ,  $I_O = 300\text{ mA}$ ,  $EN = V_{IN}$ ,  $ILIM = V_{IN}$ ,  $T_A = -40^\circ\text{C}$  to  $85^\circ\text{C}$  (unless otherwise noted)

PARAMETER		TEST CONDITIONS	MIN	TYP	MAX	UNIT
$V_O$	Adjustable output voltage range	TPS62000	0.8		5.5	V
$V_{ref}$	Reference voltage	TPS6200x		0.45		V
$V_O$	Fixed output voltage <sup>(1)</sup>	TPS62000 adjustable	$V_I = 2.5\text{ V to } 5.5\text{ V}; 0\text{ mA} \leq I_O \leq 600\text{ mA}$	-3%		4%
			$10\text{ mA} < I_O \leq 600\text{ mA}$	-3%		3%
		TPS62001 0.9 V	$V_I = 2.5\text{ V to } 5.5\text{ V}; 0\text{ mA} \leq I_O \leq 600\text{ mA}$	-3%		4%
			$10\text{ mA} < I_O \leq 600\text{ mA}$	-3%		3%
		TPS62002 1 V	$V_I = 2.5\text{ V to } 5.5\text{ V}; 0\text{ mA} \leq I_O \leq 600\text{ mA}$	-3%		4%
			$10\text{ mA} < I_O \leq 600\text{ mA}$	-3%		3%
		TPS62003 1.2 V	$V_I = 2.5\text{ V to } 5.5\text{ V}; 0\text{ mA} \leq I_O \leq 600\text{ mA}$	-3%		4%
			$10\text{ mA} < I_O \leq 600\text{ mA}$	-3%		3%
		TPS62004 1.5 V	$V_I = 2.5\text{ V to } 5.5\text{ V}; 0\text{ mA} \leq I_O \leq 600\text{ mA}$	-3%		4%
			$10\text{ mA} < I_O \leq 600\text{ mA}$	-3%		3%
		TPS62005 1.8 V	$V_I = 2.5\text{ V to } 5.5\text{ V}; 0\text{ mA} \leq I_O \leq 600\text{ mA}$	-3%		4%
			$10\text{ mA} < I_O \leq 600\text{ mA}$	-3%		3%
		TPS62008 1.9 V	$V_I = 2.5\text{ V to } 5.5\text{ V}; 0\text{ mA} \leq I_O \leq 600\text{ mA}$	-3%		4%
			$10\text{ mA} < I_O \leq 600\text{ mA}$	-3%		3%
TPS62006 2.5 V	$V_I = 2.7\text{ V to } 5.5\text{ V}; 0\text{ mA} \leq I_O \leq 600\text{ mA}$	-3%		4%		
	$10\text{ mA} < I_O \leq 600\text{ mA}$	-3%		3%		
TPS62007 3.3 V	$V_I = 3.6\text{ V to } 5.5\text{ V}; 0\text{ mA} \leq I_O \leq 600\text{ mA}$	-3%		4%		
	$10\text{ mA} < I_O \leq 600\text{ mA}$	-3%		3%		
	Line regulation	$V_I = V_O + 0.5\text{ V (min. } 2\text{ V) to } 5.5\text{ V}, I_O = 10\text{ mA}$		0.05		%/V
	Load regulation	$V_I = 5.5\text{ V}; I_O = 10\text{ mA to } 600\text{ mA}$		0.6%		
$\eta$	Efficiency	$V_I = 5\text{ V}; V_O = 3.3\text{ V}; I_O = 300\text{ mA}$		95%		
		$V_I = 3.6\text{ V}; V_O = 2.5\text{ V}; I_O = 200\text{ mA}$				
	Start-up time	$I_O = 0\text{ mA}$ , time from active EN to $V_O$	0.4		2	ms

(1) The output voltage accuracy includes line and load regulation over the full temperature range,  $T_A = -40^\circ\text{C}$  to  $85^\circ\text{C}$ .

TYPICAL CHARACTERISTICS

TABLE OF GRAPHS

			FIGURE
$\eta$	Efficiency	vs Load current	3, 4, 5
$V_{(drop)}$	Dropout voltage	vs Load current	6
$I_Q$	Operating quiescent current	vs Input voltage (power save mode)	7
		vs Input voltage (forced PWM)	8
$f_{OSC}$	Oscillator frequency	vs Free-air temperature	9
	Load transient response		10
	Line transient response		11
	Power save mode operation		12
	Start-up	vs Time	13
$V_O$	Output voltage	vs Load current	14

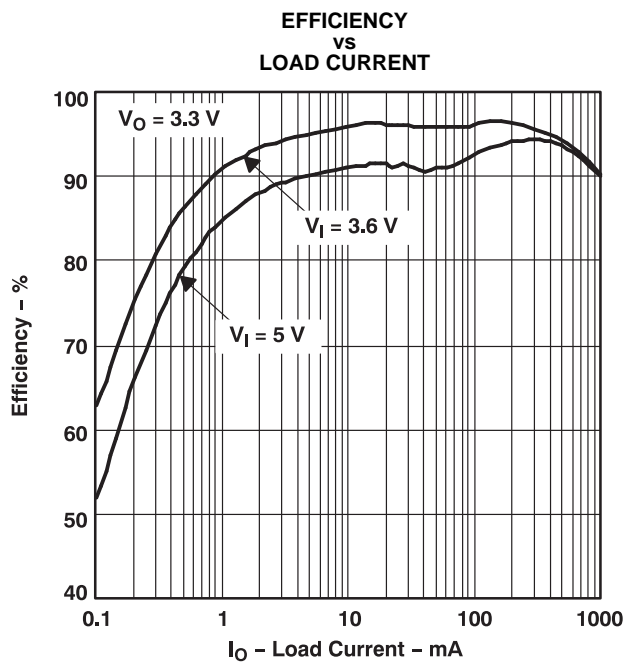

Figure 3.

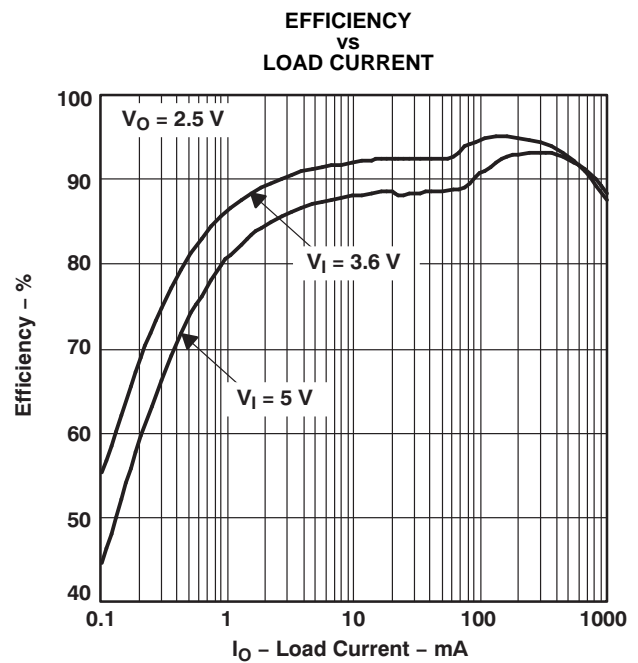

Figure 4.

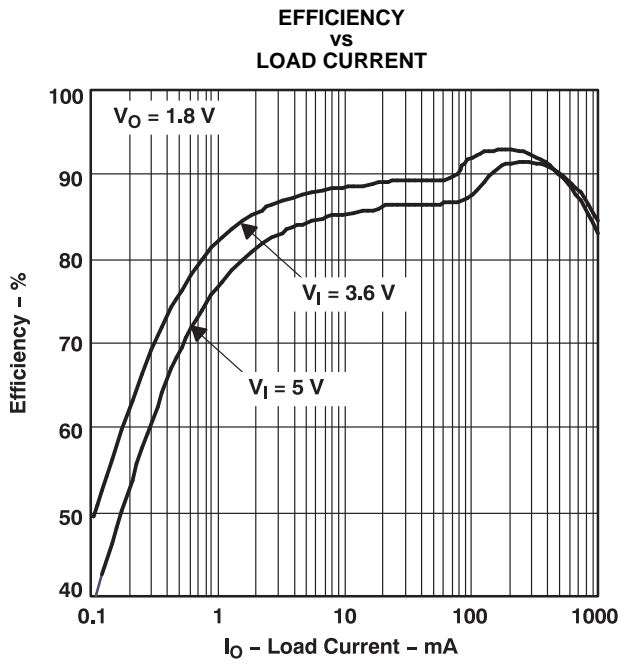

Figure 5.

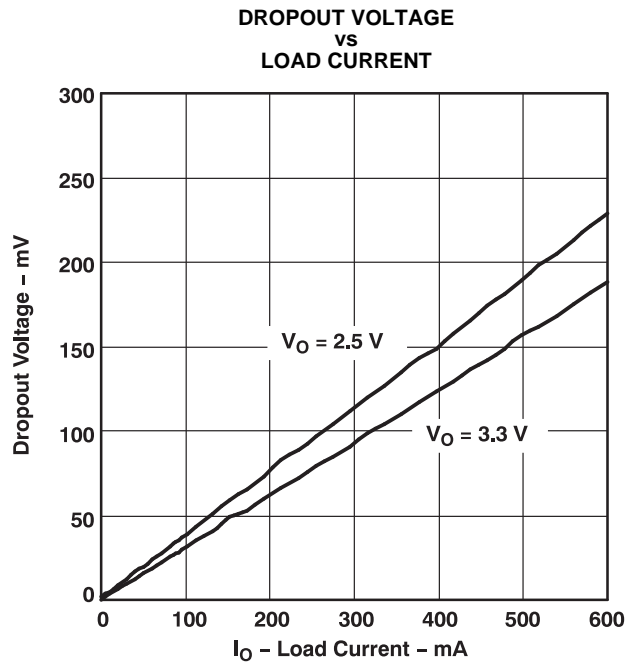

Figure 6.

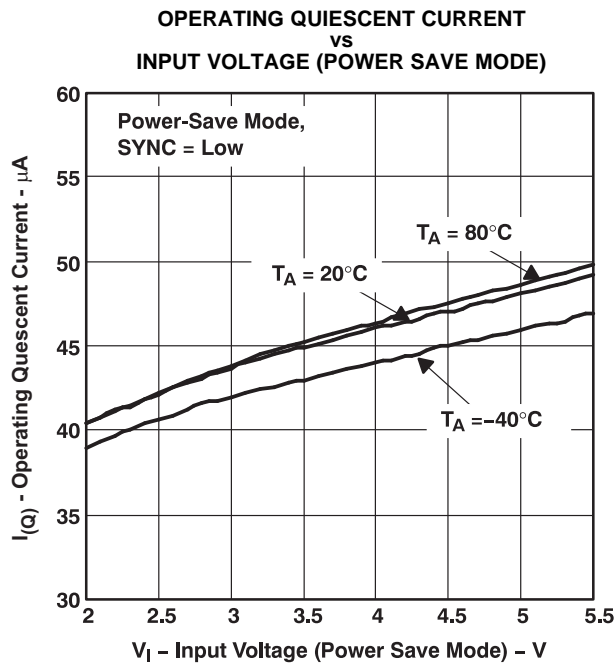

Figure 7.

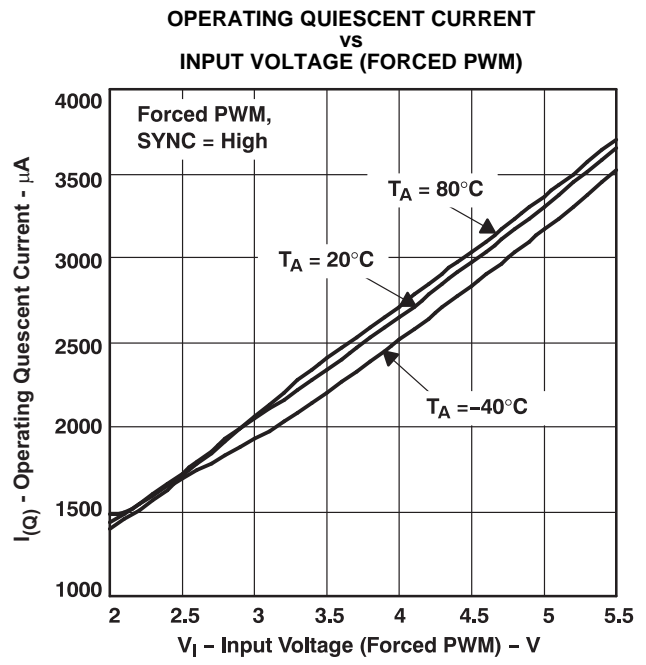

Figure 8.

OSCILLATOR FREQUENCY  
 vs  
 FREE-AIR TEMPERATURE

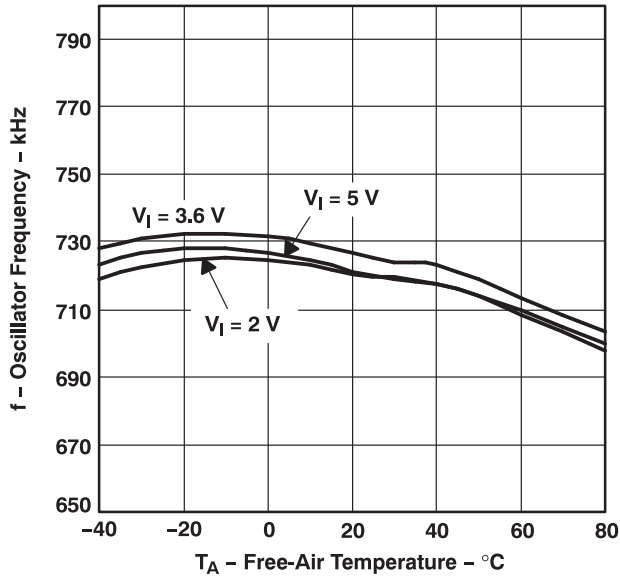

Figure 9.

LOAD TRANSIENT RESPONSE

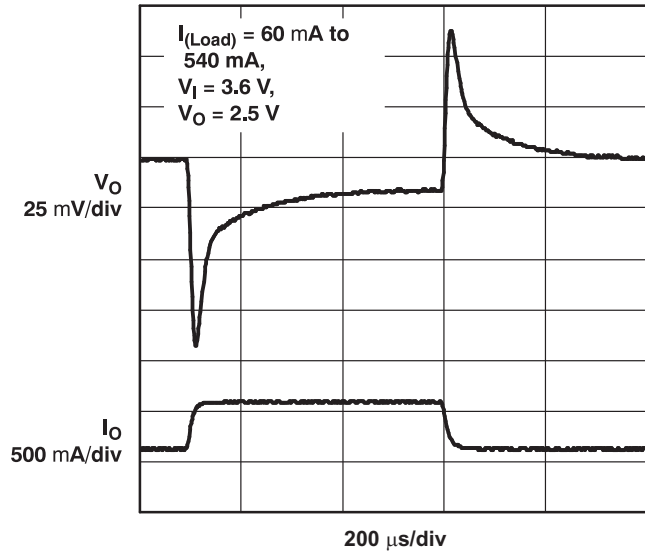

Figure 10.

LINE TRANSIENT RESPONSE

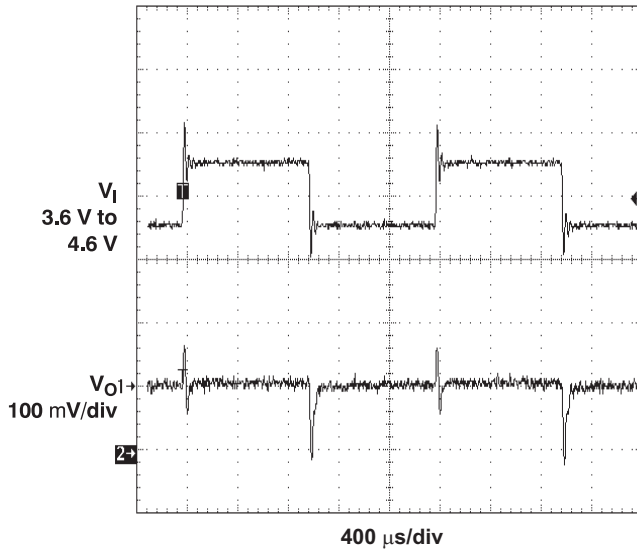

Figure 11.

POWER SAVE MODE OPERATION

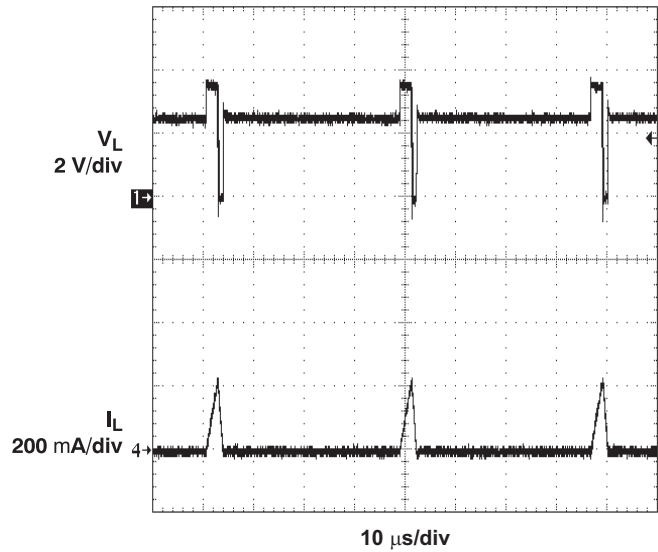

Figure 12.

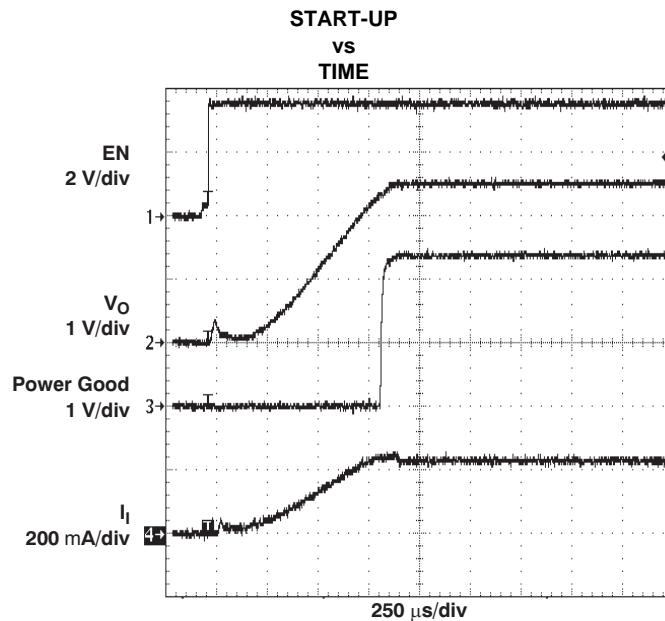

Figure 13.

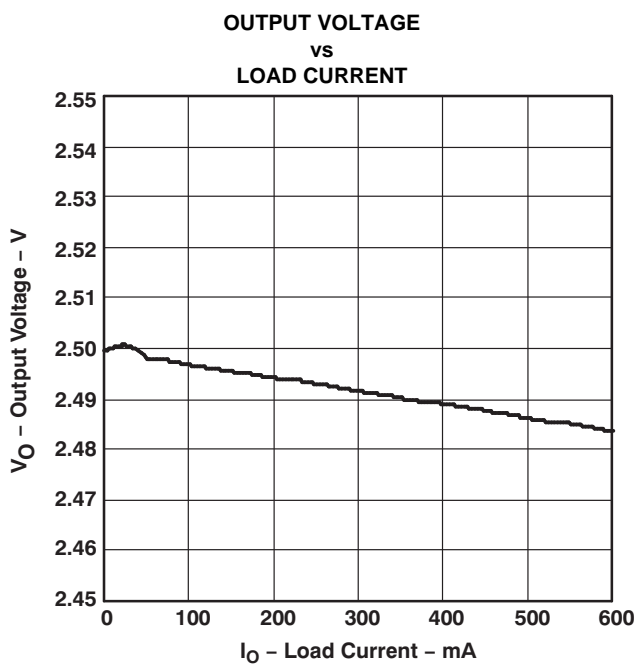

Figure 14.

## APPLICATION INFORMATION

### ADJUSTABLE OUTPUT VOLTAGE VERSION

When the adjustable output voltage version (TPS62000DGS) is used, the output voltage is set by the external resistor divider (see [Figure 15](#)).

The output voltage is calculated as:

$$V_O = 0.45 \text{ V} \times \left( 1 + \frac{R_1}{R_2} \right) \quad (1)$$

With  $R_1 + R_2 \leq 1 \text{ M}\Omega$

$R_1 + R_2$  should not be greater than 1 MW because of stability reasons.

For stability reasons, a small bypass capacitor ( $C_{ff}$ ) is required in parallel to the upper feedback resistor, refer to [Figure 15](#). The bypass capacitor value can be calculated as:

$$C_{(ff)} = \frac{1}{2\pi \times 30000 \times R_1} \text{ for } C_o < 47 \mu\text{F} \quad (2)$$

$$C_{(ff)} = \frac{1}{2\pi \times 5000 \times R_1} \text{ for } C_o \geq 47 \mu\text{F} \quad (3)$$

$R_1$  is the upper resistor of the voltage divider. For  $C_{(ff)}$ , choose a value which comes closest to the computed result.

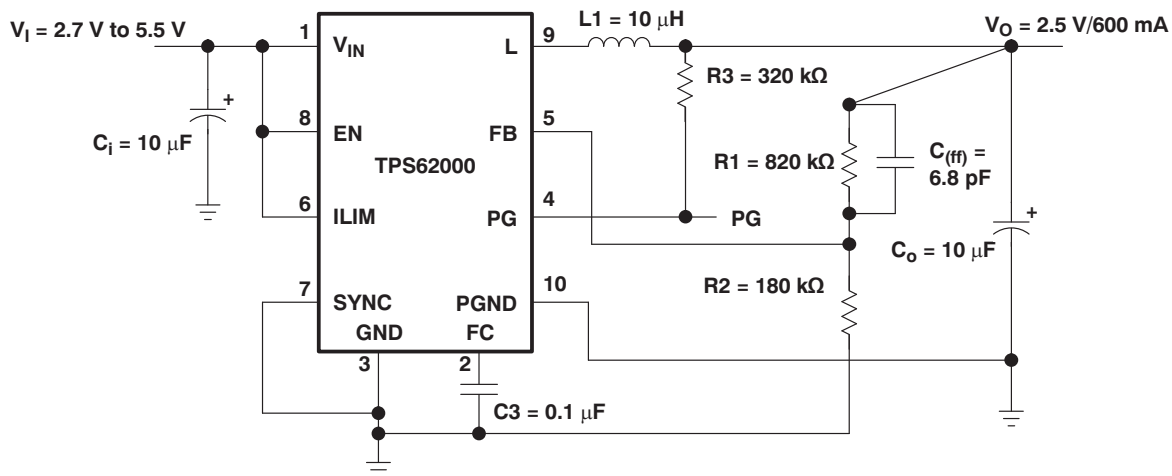

**Figure 15. Typical Application Circuit for Adjustable Output Voltage Option**

### INDUCTOR SELECTION

A 10 µH minimum output inductor is used with the TPS6200x. Values larger than 22 µH or smaller than 10 µH may cause stability problems because of the internal compensation of the regulator.

For output voltages greater than 1.8 V, a 22 µH inductance might be used in order to improve the efficiency of the converter.

After choosing the inductor value of typically 10 µH, two additional inductor parameters should be considered: first the current rating of the inductor and second the dc resistance.

The dc resistance of the inductance influences directly the efficiency of the converter. Therefore, an inductor with lowest dc resistance should be selected for highest efficiency.

In order to avoid saturation of the inductor, the inductor should be rated at least for the maximum output current plus the inductor ripple current which is calculated as:

$$\Delta I_L = V_O \times \frac{1 - \frac{V_O}{V_I}}{L \times f} \quad I_{L(\max)} = I_{O(\max)} + \frac{\Delta I_L}{2} \quad (4)$$

Where:

$f$  = Switching frequency (750 kHz typical)

$L$  = Inductor value

$\Delta I_L$  = Peak-to-peak inductor ripple current

$I_{L(\max)}$  = Maximum inductor current

The highest inductor current occurs at maximum  $V_I$ .

A more conservative approach is to select the inductor current rating just for the maximum switch current of the TPS6200x which is 1.6 A with  $I_{LIM} = V_{IN}$  and 900 mA with  $I_{LIM} = GND$ . See [Table 1](#) for recommended inductors.

**Table 1. Tested Inductors**

OUTPUT CURRENT	INDUCTOR VALUE	COMPONENT SUPPLIER	COMMENTS
0 mA to 600 mA	10 $\mu$ H	Coilcraft DO3316P-103 Coilcraft DT3316P-103 Sumida CDR63B-100 Sumida CDRH5D28-100	High efficiency
		Coilcraft DO1608C-103 Sumida CDRH4D28-100	Smallest solution
0 mA to 300 mA	10 $\mu$ H	Coilcraft DO1608C-103	High efficiency
		Murata LQH4C100K04	Smallest solution

## OUTPUT CAPACITOR SELECTION

For best performance, a low ESR output capacitor is needed. At output voltages greater than 1.8 V, ceramic output capacitors can be used to show the best performance. Output voltages below 1.8 V require a larger output capacitor and ESR value to improve the performance and stability of the converter.

**Table 2. Capacitor Selection**

OUTPUT VOLTAGE RANGE	OUTPUT CAPACITOR	OUTPUT CAPACITOR ESR
1.8 V $\leq V_I \leq$ 5.5 V	$C_O \geq 10 \mu$ F	ESR $\leq 120$ m $\Omega$
0.8 V $\leq V_I <$ 1.8 V	$C_O \geq 47 \mu$ F	ESR $> 50$ m $\Omega$

See [Table 3](#) for recommended capacitors.

If an output capacitor is selected with an ESR value  $\leq 120$  m $\Omega$ , its RMS ripple current rating always meets the application requirements. Just for completeness, the RMS ripple current is calculated as:

$$I_{RMS(C_O)} = V_O \times \frac{1 - \frac{V_O}{V_I}}{L \times f} \times \frac{1}{2 \times \sqrt{3}} \quad (5)$$

The overall output ripple voltage is the sum of the voltage spike caused by the output capacitor ESR plus the voltage ripple caused by charge and discharging the output capacitor:

$$\Delta V_O = V_O \times \frac{1 - \frac{V_O}{V_I}}{L \times f} \times \left( \frac{1}{8 \times C_O \times f} + \text{ESR} \right) \quad (6)$$

Where the highest output voltage ripple occurs at the highest input voltage  $V_I$ .

Table 3. Tested Capacitors

CAPACITOR VALUE	ESR/mΩ	COMPONENT SUPPLIER	COMMENTS
10 μF	50	Taiyo Yuden JMK316BJ106KL	Ceramic
47 μF	100	Sanyo 6TPA47M	POSCAP
68 μF	100	Sprague 594D686X0010C2T	Tantalum

## INPUT CAPACITOR SELECTION

Because of the nature of the buck converter having a pulsating input current, a low ESR input capacitor is required for best input voltage filtering and minimizing the interference with other circuits caused by high input voltage spikes.

The input capacitor should have a minimum value of 10 μF and can be increased without any limit for better input voltage filtering.

The input capacitor should be rated for the maximum input ripple current calculated as:

$$I_{RMS} = I_{O(max)} \times \sqrt{\frac{V_O}{V_I} \times \left(1 - \frac{V_O}{V_I}\right)} \quad (7)$$

The worst case RMS ripple current occurs at  $D = 0.5$  and is calculated as:  $I_{RMS} = \frac{I_O}{2}$

Ceramic capacitor show a good performance because of their low ESR value, and they are less sensitive against voltage transients compared to tantalum capacitors.

Place the input capacitor as close as possible to the input pin of the IC for best performance.

## LAYOUT CONSIDERATIONS

As for all switching power supplies, the layout is an important step in the design especially at high peak currents and switching frequencies. If the layout is not carefully done, the regulator might show stability problems as well as EMI problems.

Therefore, use wide and short traces for the main current paths as indicted in bold in Figure 16. The input capacitor should be placed as close as possible to the IC pins as well as the inductor and output capacitor. Place the bypass capacitor, C3, as close as possible to the FC pin. The analog ground, GND, and the power ground, PGND, need to be separated. Use a common ground node as shown in Figure 16 to minimize the effects of ground noise.

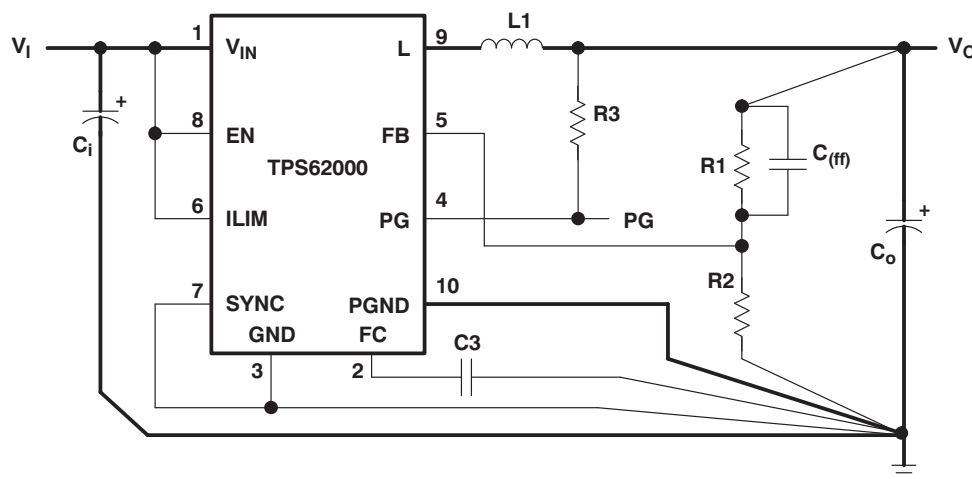

Figure 16. Layout Diagram

TYPICAL APPLICATION

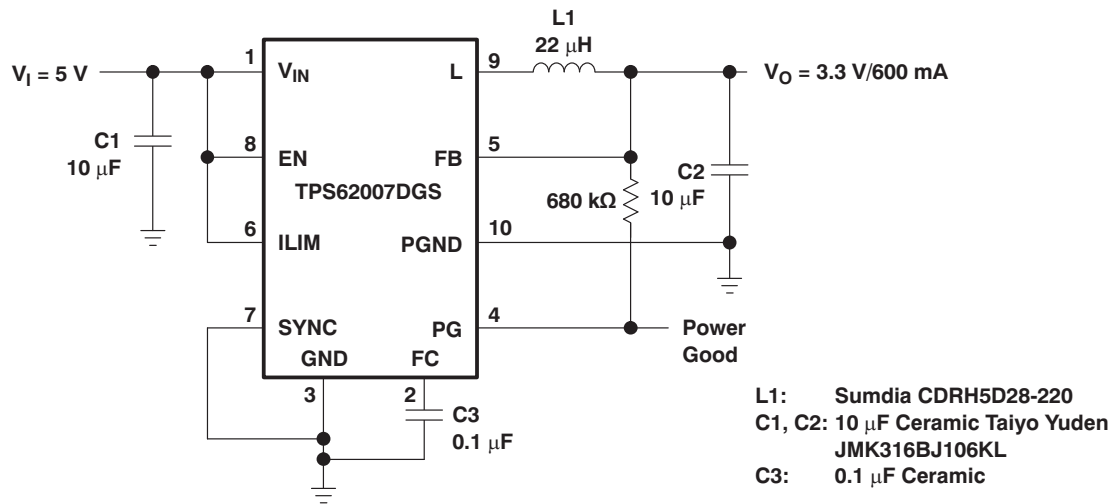

Figure 17. Standard 5 V to 3.3 V/600 mA Conversion; High Efficiency

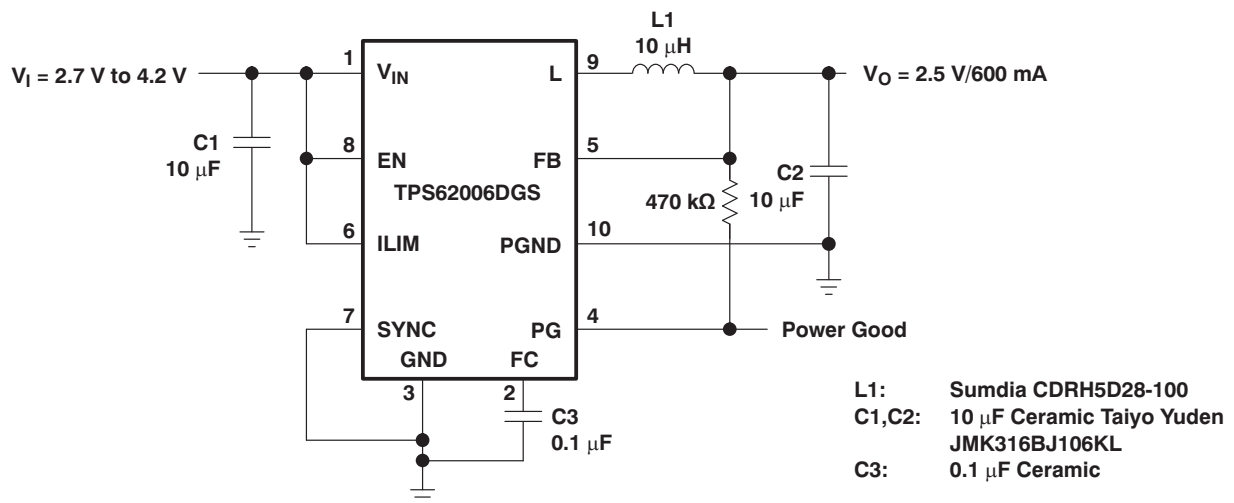
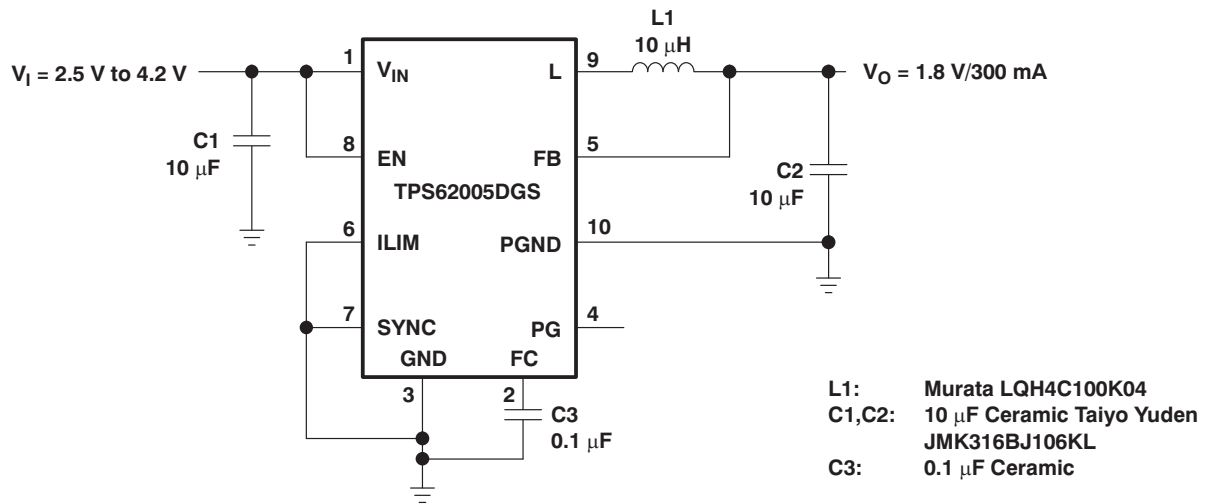

Figure 18. Single Li-ion to 2.5 V/600 mA Using Ceramic Capacitors Only



NOTE: For low noise operation connect SYNC to  $V_{IN}$

Figure 19. Single Li-ion to 1.8 V/300 mA; Smallest Solution Size

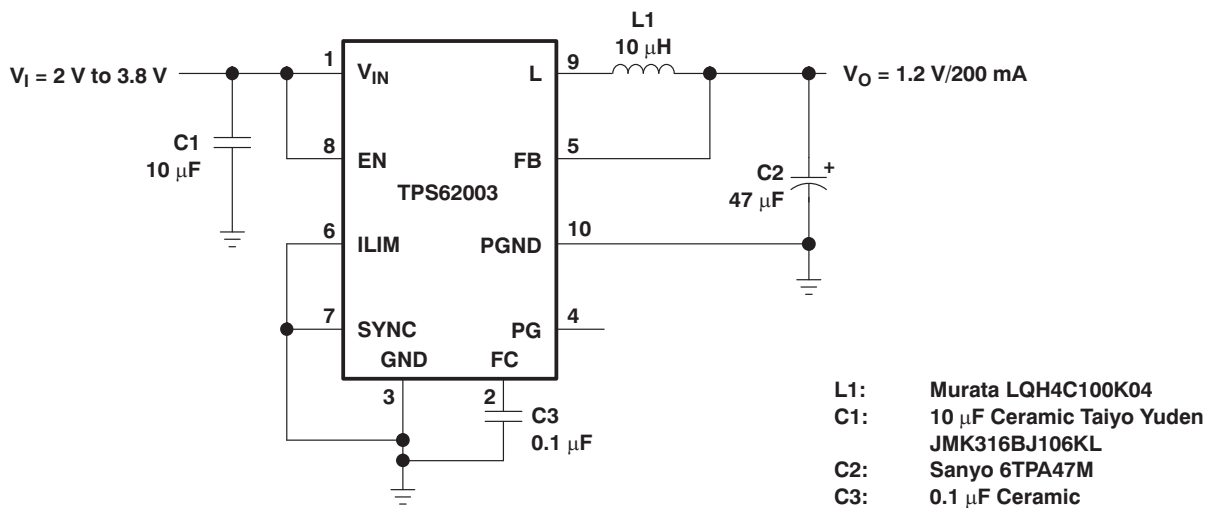
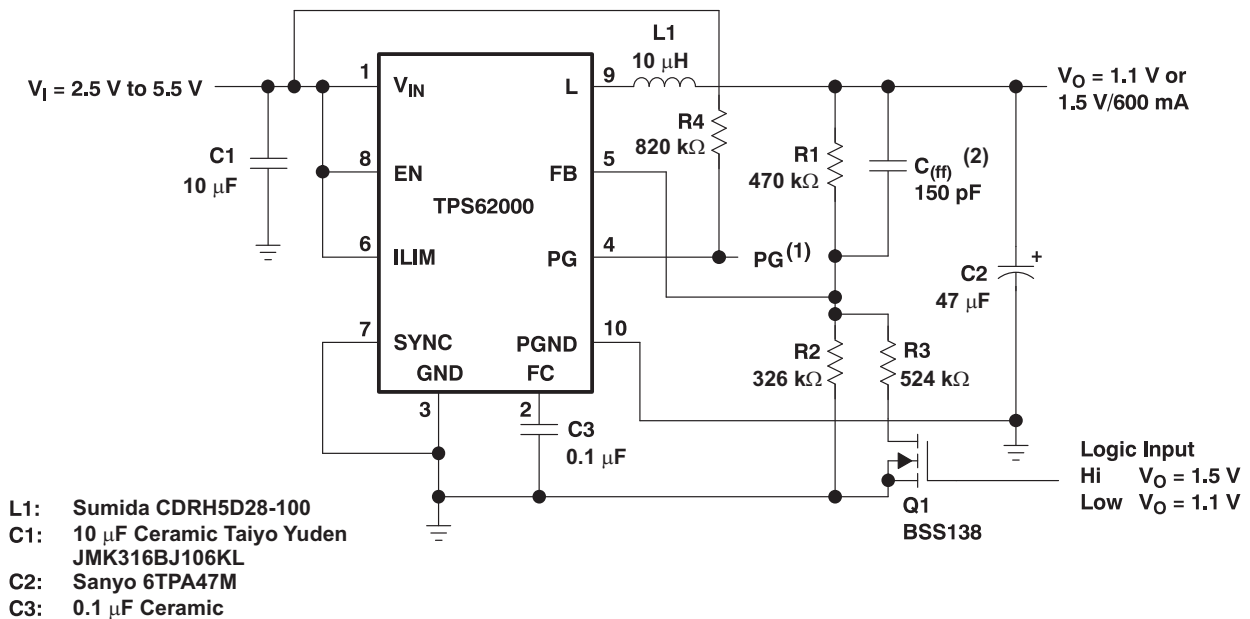

Figure 20. Dual Cell NiMH or NiCd to 1.2 V/200 mA; Smallest Solution Size



**Figure 21. Dynamic Output Voltage Programming As Used in Low Power DSP Applications**

**PACKAGING INFORMATION**

Orderable Device	Status (1)	Package Type	Package Drawing	Pins	Package Qty	Eco Plan (2)	Lead/Ball Finish (6)	MSL Peak Temp (3)	Op Temp (°C)	Device Marking (4/5)	Samples
TPS62000DGS	ACTIVE	VSSOP	DGS	10	80	Green (RoHS & no Sb/Br)	CU NIPDAUAG	Level-1-260C-UNLIM	-40 to 85	AIH	<a href="#">Samples</a>
TPS62000DGSG4	ACTIVE	VSSOP	DGS	10	80	Green (RoHS & no Sb/Br)	CU NIPDAUAG	Level-1-260C-UNLIM	-40 to 85	AIH	<a href="#">Samples</a>
TPS62000DGSR	ACTIVE	VSSOP	DGS	10	2500	Green (RoHS & no Sb/Br)	CU NIPDAU   CU NIPDAUAG	Level-1-260C-UNLIM	-40 to 85	AIH	<a href="#">Samples</a>
TPS62000DGSRG4	ACTIVE	VSSOP	DGS	10	2500	Green (RoHS & no Sb/Br)	CU NIPDAU	Level-1-260C-UNLIM	-40 to 85	AIH	<a href="#">Samples</a>
TPS62000YZGR	OBSOLETE	DSBGA	YZG	12		TBD	Call TI	Call TI	-40 to 85	TPS62000	
TPS62000YZGT	OBSOLETE	DSBGA	YZG	12		TBD	Call TI	Call TI	-40 to 85		
TPS62002DGS	ACTIVE	VSSOP	DGS	10	80	Green (RoHS & no Sb/Br)	CU NIPDAUAG	Level-1-260C-UNLIM	-40 to 85	AIJ	<a href="#">Samples</a>
TPS62002DGSG4	ACTIVE	VSSOP	DGS	10	80	Green (RoHS & no Sb/Br)	CU NIPDAUAG	Level-1-260C-UNLIM	-40 to 85	AIJ	<a href="#">Samples</a>
TPS62002DGSR	ACTIVE	VSSOP	DGS	10	2500	Green (RoHS & no Sb/Br)	CU NIPDAUAG	Level-1-260C-UNLIM	-40 to 85	AIJ	<a href="#">Samples</a>
TPS62002DGSRG4	ACTIVE	VSSOP	DGS	10	2500	Green (RoHS & no Sb/Br)	CU NIPDAUAG	Level-1-260C-UNLIM	-40 to 85	AIJ	<a href="#">Samples</a>
TPS62003DGS	ACTIVE	VSSOP	DGS	10	80	Green (RoHS & no Sb/Br)	CU NIPDAUAG	Level-1-260C-UNLIM	-40 to 85	AIK	<a href="#">Samples</a>
TPS62003DGSG4	ACTIVE	VSSOP	DGS	10	80	Green (RoHS & no Sb/Br)	CU NIPDAUAG	Level-1-260C-UNLIM	-40 to 85	AIK	<a href="#">Samples</a>
TPS62003DGSR	ACTIVE	VSSOP	DGS	10	2500	Green (RoHS & no Sb/Br)	CU NIPDAUAG	Level-1-260C-UNLIM	-40 to 85	AIK	<a href="#">Samples</a>
TPS62003DGSRG4	ACTIVE	VSSOP	DGS	10	2500	Green (RoHS & no Sb/Br)	CU NIPDAUAG	Level-1-260C-UNLIM	-40 to 85	AIK	<a href="#">Samples</a>
TPS62004DGS	ACTIVE	VSSOP	DGS	10	80	Green (RoHS & no Sb/Br)	CU NIPDAUAG	Level-1-260C-UNLIM	-40 to 85	AIL	<a href="#">Samples</a>
TPS62004DGSG4	ACTIVE	VSSOP	DGS	10	80	Green (RoHS & no Sb/Br)	CU NIPDAUAG	Level-1-260C-UNLIM	-40 to 85	AIL	<a href="#">Samples</a>
TPS62004DGSR	ACTIVE	VSSOP	DGS	10	2500	Green (RoHS & no Sb/Br)	CU NIPDAUAG	Level-1-260C-UNLIM	-40 to 85	AIL	<a href="#">Samples</a>
TPS62004DGSRG4	ACTIVE	VSSOP	DGS	10	2500	Green (RoHS & no Sb/Br)	CU NIPDAUAG	Level-1-260C-UNLIM	-40 to 85	AIL	<a href="#">Samples</a>

Orderable Device	Status (1)	Package Type	Package Drawing	Pins	Package Qty	Eco Plan (2)	Lead/Ball Finish (6)	MSL Peak Temp (3)	Op Temp (°C)	Device Marking (4/5)	Samples
TPS62005DGS	ACTIVE	VSSOP	DGS	10	80	Green (RoHS & no Sb/Br)	CU NIPDAUAG	Level-1-260C-UNLIM	-40 to 85	AIM	<a href="#">Samples</a>
TPS62005DGSG4	ACTIVE	VSSOP	DGS	10	80	Green (RoHS & no Sb/Br)	CU NIPDAUAG	Level-1-260C-UNLIM	-40 to 85	AIM	<a href="#">Samples</a>
TPS62005DGSR	ACTIVE	VSSOP	DGS	10	2500	Green (RoHS & no Sb/Br)	CU NIPDAUAG	Level-1-260C-UNLIM	-40 to 85	AIM	<a href="#">Samples</a>
TPS62005DGSRG4	ACTIVE	VSSOP	DGS	10	2500	Green (RoHS & no Sb/Br)	CU NIPDAUAG	Level-1-260C-UNLIM	-40 to 85	AIM	<a href="#">Samples</a>
TPS62006DGS	ACTIVE	VSSOP	DGS	10	80	Green (RoHS & no Sb/Br)	CU NIPDAUAG	Level-1-260C-UNLIM	-40 to 85	AIN	<a href="#">Samples</a>
TPS62006DGSG4	ACTIVE	VSSOP	DGS	10	80	Green (RoHS & no Sb/Br)	CU NIPDAUAG	Level-1-260C-UNLIM	-40 to 85	AIN	<a href="#">Samples</a>
TPS62006DGSR	ACTIVE	VSSOP	DGS	10	2500	Green (RoHS & no Sb/Br)	CU NIPDAUAG	Level-1-260C-UNLIM	-40 to 85	AIN	<a href="#">Samples</a>
TPS62006DGSRG4	ACTIVE	VSSOP	DGS	10	2500	Green (RoHS & no Sb/Br)	CU NIPDAUAG	Level-1-260C-UNLIM	-40 to 85	AIN	<a href="#">Samples</a>
TPS62007DGS	ACTIVE	VSSOP	DGS	10	80	Green (RoHS & no Sb/Br)	CU NIPDAU   CU NIPDAUAG	Level-1-260C-UNLIM	-40 to 85	AIO	<a href="#">Samples</a>
TPS62007DGSG4	ACTIVE	VSSOP	DGS	10	80	Green (RoHS & no Sb/Br)	CU NIPDAU	Level-1-260C-UNLIM	-40 to 85	AIO	<a href="#">Samples</a>
TPS62007DGSR	ACTIVE	VSSOP	DGS	10	2500	Green (RoHS & no Sb/Br)	CU NIPDAU   CU NIPDAUAG	Level-1-260C-UNLIM	-40 to 85	AIO	<a href="#">Samples</a>
TPS62007DGSRG4	ACTIVE	VSSOP	DGS	10	2500	Green (RoHS & no Sb/Br)	CU NIPDAU	Level-1-260C-UNLIM	-40 to 85	AIO	<a href="#">Samples</a>
TPS62008DGS	ACTIVE	VSSOP	DGS	10	80	Green (RoHS & no Sb/Br)	CU NIPDAUAG	Level-1-260C-UNLIM	-40 to 85	AJI	<a href="#">Samples</a>
TPS62008DGSG4	ACTIVE	VSSOP	DGS	10	80	Green (RoHS & no Sb/Br)	CU NIPDAUAG	Level-1-260C-UNLIM	-40 to 85	AJI	<a href="#">Samples</a>
TPS62008DGSR	ACTIVE	VSSOP	DGS	10	2500	Green (RoHS & no Sb/Br)	CU NIPDAUAG	Level-1-260C-UNLIM	-40 to 85	AJI	<a href="#">Samples</a>
TPS62008DGSRG4	ACTIVE	VSSOP	DGS	10	2500	Green (RoHS & no Sb/Br)	CU NIPDAUAG	Level-1-260C-UNLIM	-40 to 85	AJI	<a href="#">Samples</a>

(1) The marketing status values are defined as follows:

**ACTIVE:** Product device recommended for new designs.

**LIFEBUY:** TI has announced that the device will be discontinued, and a lifetime-buy period is in effect.

**NRND:** Not recommended for new designs. Device is in production to support existing customers, but TI does not recommend using this part in a new design.

**PREVIEW:** Device has been announced but is not in production. Samples may or may not be available.

**OBSOLETE:** TI has discontinued the production of the device.

(2) Eco Plan - The planned eco-friendly classification: Pb-Free (RoHS), Pb-Free (RoHS Exempt), or Green (RoHS & no Sb/Br) - please check <http://www.ti.com/productcontent> for the latest availability information and additional product content details.

**TBD:** The Pb-Free/Green conversion plan has not been defined.

**Pb-Free (RoHS):** TI's terms "Lead-Free" or "Pb-Free" mean semiconductor products that are compatible with the current RoHS requirements for all 6 substances, including the requirement that lead not exceed 0.1% by weight in homogeneous materials. Where designed to be soldered at high temperatures, TI Pb-Free products are suitable for use in specified lead-free processes.

**Pb-Free (RoHS Exempt):** This component has a RoHS exemption for either 1) lead-based flip-chip solder bumps used between the die and package, or 2) lead-based die adhesive used between the die and leadframe. The component is otherwise considered Pb-Free (RoHS compatible) as defined above.

**Green (RoHS & no Sb/Br):** TI defines "Green" to mean Pb-Free (RoHS compatible), and free of Bromine (Br) and Antimony (Sb) based flame retardants (Br or Sb do not exceed 0.1% by weight in homogeneous material)

(3) MSL, Peak Temp. - The Moisture Sensitivity Level rating according to the JEDEC industry standard classifications, and peak solder temperature.

(4) There may be additional marking, which relates to the logo, the lot trace code information, or the environmental category on the device.

(5) Multiple Device Markings will be inside parentheses. Only one Device Marking contained in parentheses and separated by a "~" will appear on a device. If a line is indented then it is a continuation of the previous line and the two combined represent the entire Device Marking for that device.

(6) Lead/Ball Finish - Orderable Devices may have multiple material finish options. Finish options are separated by a vertical ruled line. Lead/Ball Finish values may wrap to two lines if the finish value exceeds the maximum column width.

**Important Information and Disclaimer:** The information provided on this page represents TI's knowledge and belief as of the date that it is provided. TI bases its knowledge and belief on information provided by third parties, and makes no representation or warranty as to the accuracy of such information. Efforts are underway to better integrate information from third parties. TI has taken and continues to take reasonable steps to provide representative and accurate information but may not have conducted destructive testing or chemical analysis on incoming materials and chemicals. TI and TI suppliers consider certain information to be proprietary, and thus CAS numbers and other limited information may not be available for release.

In no event shall TI's liability arising out of such information exceed the total purchase price of the TI part(s) at issue in this document sold by TI to Customer on an annual basis.

**OTHER QUALIFIED VERSIONS OF TPS62000, TPS62004, TPS62005, TPS62006, TPS62007 :**

- Automotive: [TPS62000-Q1](#), [TPS62004-Q1](#), [TPS62005-Q1](#), [TPS62006-Q1](#), [TPS62007-Q1](#)

NOTE: Qualified Version Definitions:

- Automotive - Q100 devices qualified for high-reliability automotive applications targeting zero defects

**TAPE AND REEL INFORMATION**

**QUADRANT ASSIGNMENTS FOR PIN 1 ORIENTATION IN TAPE**

\*All dimensions are nominal

Device	Package Type	Package Drawing	Pins	SPQ	Reel Diameter (mm)	Reel Width W1 (mm)	A0 (mm)	B0 (mm)	K0 (mm)	P1 (mm)	W (mm)	Pin1 Quadrant
TPS62000DGSR	VSSOP	DGS	10	2500	330.0	12.4	5.3	3.4	1.4	8.0	12.0	Q1
TPS62002DGSR	VSSOP	DGS	10	2500	330.0	12.4	5.3	3.4	1.4	8.0	12.0	Q1
TPS62003DGSR	VSSOP	DGS	10	2500	330.0	12.4	5.3	3.4	1.4	8.0	12.0	Q1
TPS62004DGSR	VSSOP	DGS	10	2500	330.0	12.4	5.3	3.4	1.4	8.0	12.0	Q1
TPS62005DGSR	VSSOP	DGS	10	2500	330.0	12.4	5.3	3.4	1.4	8.0	12.0	Q1
TPS62006DGSR	VSSOP	DGS	10	2500	330.0	12.4	5.3	3.4	1.4	8.0	12.0	Q1
TPS62007DGSR	VSSOP	DGS	10	2500	330.0	12.4	5.3	3.4	1.4	8.0	12.0	Q1
TPS62008DGSR	VSSOP	DGS	10	2500	330.0	12.4	5.3	3.4	1.4	8.0	12.0	Q1

**TAPE AND REEL BOX DIMENSIONS**

\*All dimensions are nominal

Device	Package Type	Package Drawing	Pins	SPQ	Length (mm)	Width (mm)	Height (mm)
TPS62000DGSR	VSSOP	DGS	10	2500	367.0	367.0	35.0
TPS62002DGSR	VSSOP	DGS	10	2500	367.0	367.0	35.0
TPS62003DGSR	VSSOP	DGS	10	2500	367.0	367.0	35.0
TPS62004DGSR	VSSOP	DGS	10	2500	367.0	367.0	35.0
TPS62005DGSR	VSSOP	DGS	10	2500	367.0	367.0	35.0
TPS62006DGSR	VSSOP	DGS	10	2500	367.0	367.0	35.0
TPS62007DGSR	VSSOP	DGS	10	2500	367.0	367.0	35.0
TPS62008DGSR	VSSOP	DGS	10	2500	367.0	367.0	35.0

DGS (S-PDSO-G10)

PLASTIC SMALL-OUTLINE PACKAGE

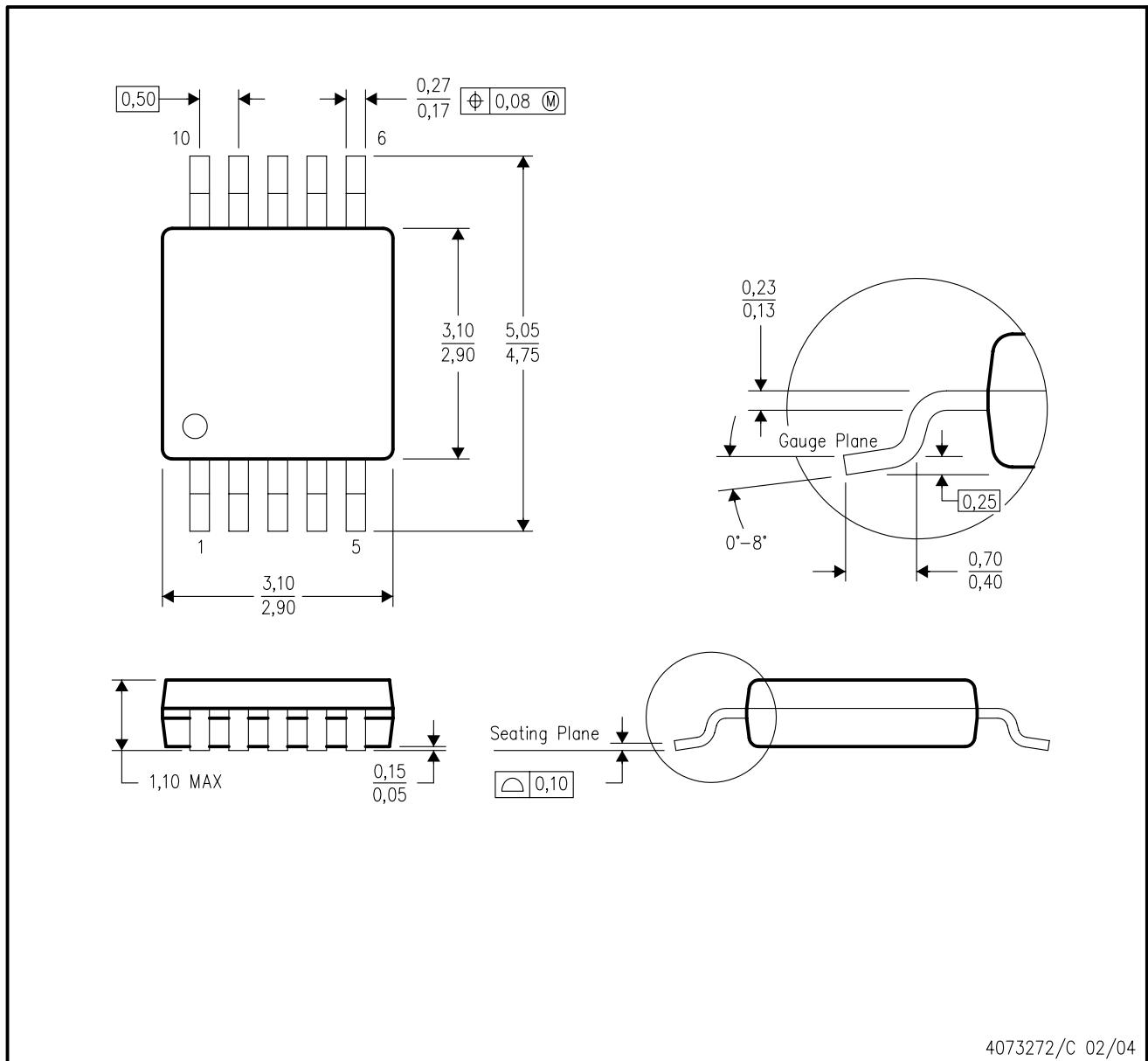

- NOTES:
- A. All linear dimensions are in millimeters.
  - B. This drawing is subject to change without notice.
  - C. Body dimensions do not include mold flash or protrusion.
  - D. Falls within JEDEC MO-187 variation BA.

DGS (S-PDSO-G10)

PLASTIC SMALL OUTLINE PACKAGE

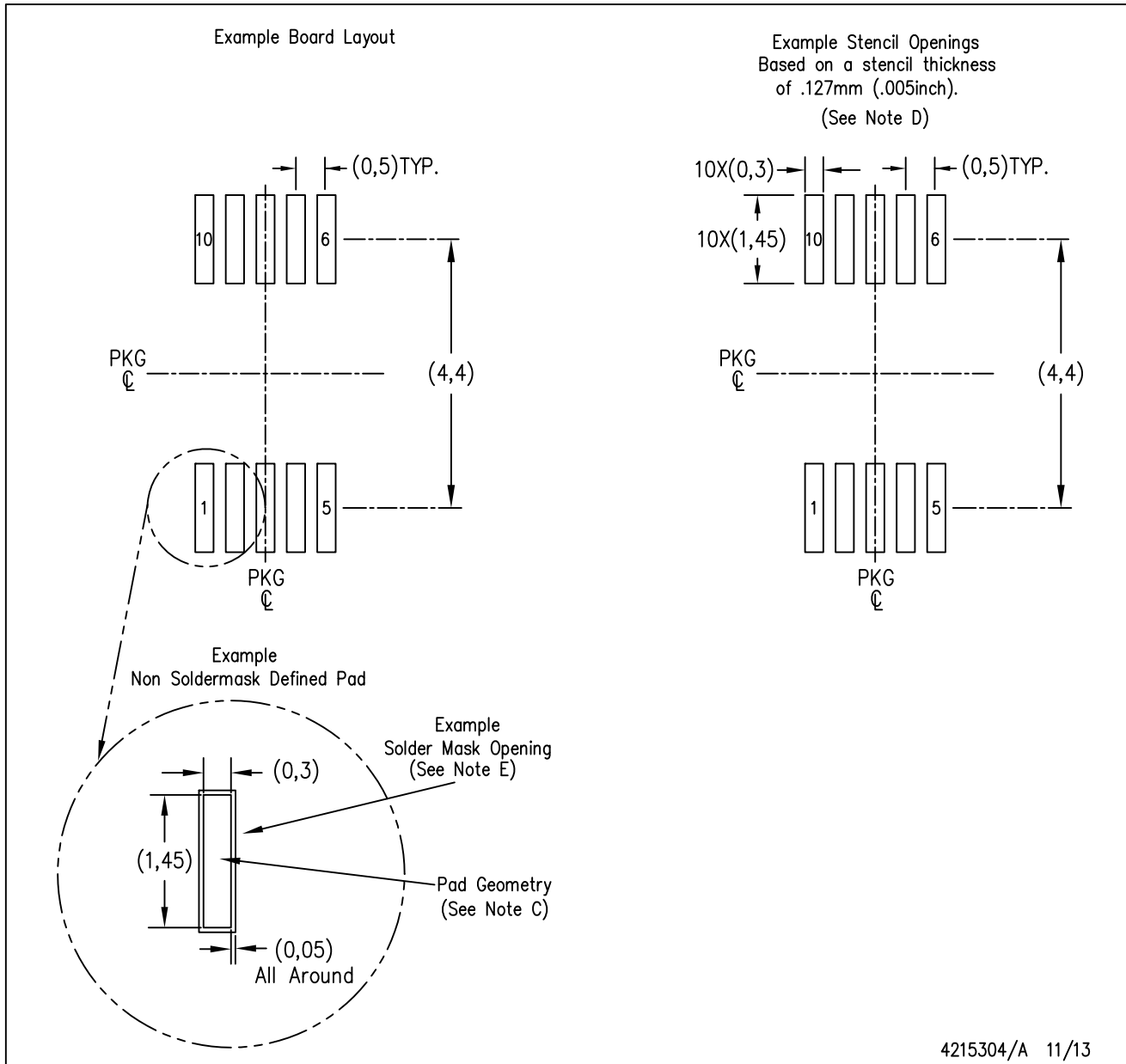

- NOTES:
- All linear dimensions are in millimeters.
  - This drawing is subject to change without notice.
  - Publication IPC-7351 is recommended for alternate designs.
  - Laser cutting apertures with trapezoidal walls and also rounding corners will offer better paste release. Customers should contact their board assembly site for stencil design recommendations. Refer to IPC-7525 for other stencil recommendations.
  - Customers should contact their board fabrication site for solder mask tolerances between and around signal pads.

YZG (R-XBGA-N12)

DIE-SIZE BALL GRID ARRAY

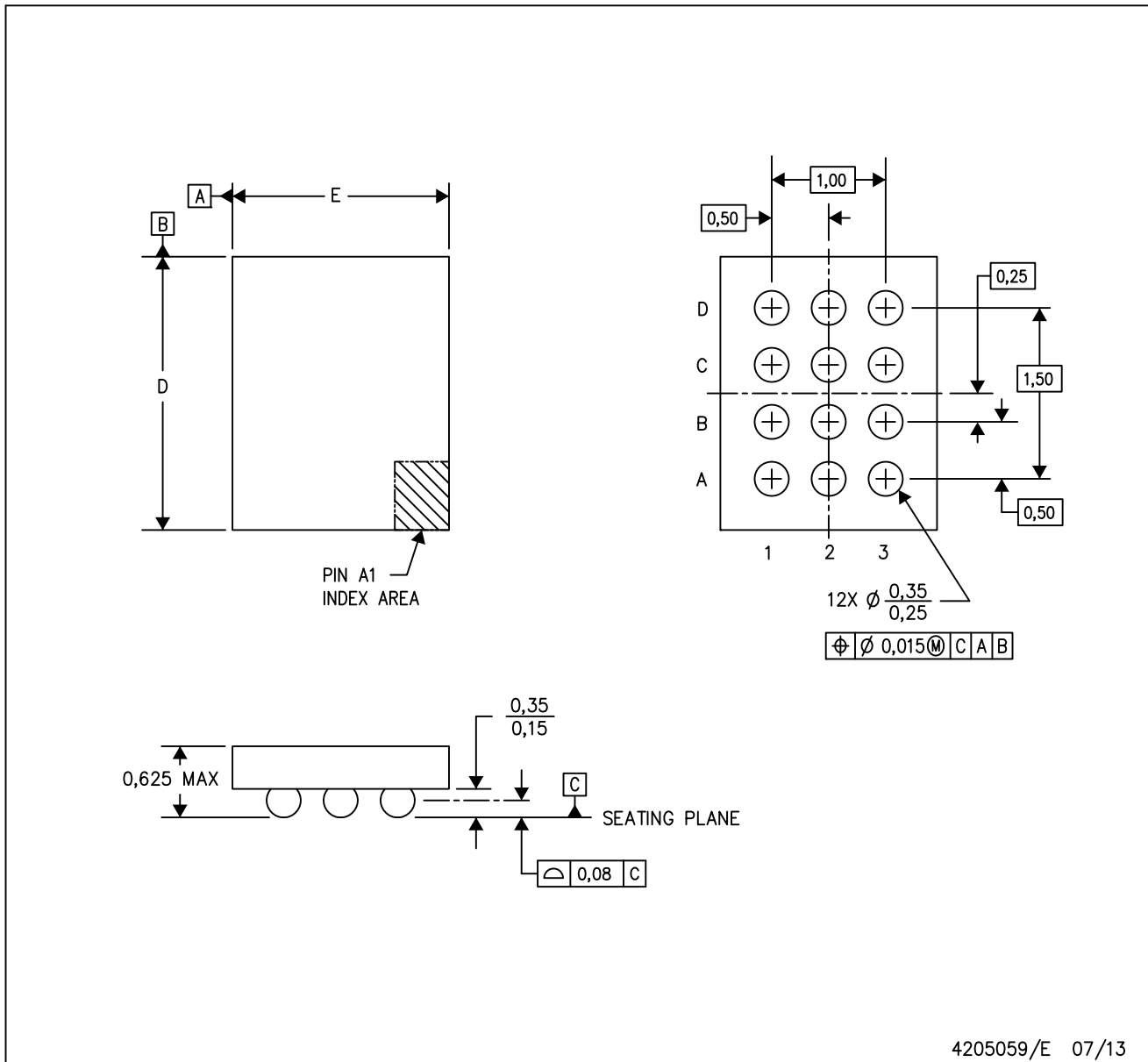

- NOTES: A. All linear dimensions are in millimeters. Dimensioning and tolerancing per ASME Y14.5M-1994.  
 B. This drawing is subject to change without notice.  
 C. NanoFree™ package configuration.

## IMPORTANT NOTICE

Texas Instruments Incorporated and its subsidiaries (TI) reserve the right to make corrections, enhancements, improvements and other changes to its semiconductor products and services per JESD46, latest issue, and to discontinue any product or service per JESD48, latest issue. Buyers should obtain the latest relevant information before placing orders and should verify that such information is current and complete. All semiconductor products (also referred to herein as "components") are sold subject to TI's terms and conditions of sale supplied at the time of order acknowledgment.

TI warrants performance of its components to the specifications applicable at the time of sale, in accordance with the warranty in TI's terms and conditions of sale of semiconductor products. Testing and other quality control techniques are used to the extent TI deems necessary to support this warranty. Except where mandated by applicable law, testing of all parameters of each component is not necessarily performed.

TI assumes no liability for applications assistance or the design of Buyers' products. Buyers are responsible for their products and applications using TI components. To minimize the risks associated with Buyers' products and applications, Buyers should provide adequate design and operating safeguards.

TI does not warrant or represent that any license, either express or implied, is granted under any patent right, copyright, mask work right, or other intellectual property right relating to any combination, machine, or process in which TI components or services are used. Information published by TI regarding third-party products or services does not constitute a license to use such products or services or a warranty or endorsement thereof. Use of such information may require a license from a third party under the patents or other intellectual property of the third party, or a license from TI under the patents or other intellectual property of TI.

Reproduction of significant portions of TI information in TI data books or data sheets is permissible only if reproduction is without alteration and is accompanied by all associated warranties, conditions, limitations, and notices. TI is not responsible or liable for such altered documentation. Information of third parties may be subject to additional restrictions.

Resale of TI components or services with statements different from or beyond the parameters stated by TI for that component or service voids all express and any implied warranties for the associated TI component or service and is an unfair and deceptive business practice. TI is not responsible or liable for any such statements.

Buyer acknowledges and agrees that it is solely responsible for compliance with all legal, regulatory and safety-related requirements concerning its products, and any use of TI components in its applications, notwithstanding any applications-related information or support that may be provided by TI. Buyer represents and agrees that it has all the necessary expertise to create and implement safeguards which anticipate dangerous consequences of failures, monitor failures and their consequences, lessen the likelihood of failures that might cause harm and take appropriate remedial actions. Buyer will fully indemnify TI and its representatives against any damages arising out of the use of any TI components in safety-critical applications.

In some cases, TI components may be promoted specifically to facilitate safety-related applications. With such components, TI's goal is to help enable customers to design and create their own end-product solutions that meet applicable functional safety standards and requirements. Nonetheless, such components are subject to these terms.

No TI components are authorized for use in FDA Class III (or similar life-critical medical equipment) unless authorized officers of the parties have executed a special agreement specifically governing such use.

Only those TI components which TI has specifically designated as military grade or "enhanced plastic" are designed and intended for use in military/aerospace applications or environments. Buyer acknowledges and agrees that any military or aerospace use of TI components which have **not** been so designated is solely at the Buyer's risk, and that Buyer is solely responsible for compliance with all legal and regulatory requirements in connection with such use.

TI has specifically designated certain components as meeting ISO/TS16949 requirements, mainly for automotive use. In any case of use of non-designated products, TI will not be responsible for any failure to meet ISO/TS16949.

### Products

Audio	<a href="http://www.ti.com/audio">www.ti.com/audio</a>
Amplifiers	<a href="http://amplifier.ti.com">amplifier.ti.com</a>
Data Converters	<a href="http://dataconverter.ti.com">dataconverter.ti.com</a>
DLP® Products	<a href="http://www.dlp.com">www.dlp.com</a>
DSP	<a href="http://dsp.ti.com">dsp.ti.com</a>
Clocks and Timers	<a href="http://www.ti.com/clocks">www.ti.com/clocks</a>
Interface	<a href="http://interface.ti.com">interface.ti.com</a>
Logic	<a href="http://logic.ti.com">logic.ti.com</a>
Power Mgmt	<a href="http://power.ti.com">power.ti.com</a>
Microcontrollers	<a href="http://microcontroller.ti.com">microcontroller.ti.com</a>
RFID	<a href="http://www.ti-rfid.com">www.ti-rfid.com</a>
OMAP Applications Processors	<a href="http://www.ti.com/omap">www.ti.com/omap</a>
Wireless Connectivity	<a href="http://www.ti.com/wirelessconnectivity">www.ti.com/wirelessconnectivity</a>

### Applications

Automotive and Transportation	<a href="http://www.ti.com/automotive">www.ti.com/automotive</a>
Communications and Telecom	<a href="http://www.ti.com/communications">www.ti.com/communications</a>
Computers and Peripherals	<a href="http://www.ti.com/computers">www.ti.com/computers</a>
Consumer Electronics	<a href="http://www.ti.com/consumer-apps">www.ti.com/consumer-apps</a>
Energy and Lighting	<a href="http://www.ti.com/energy">www.ti.com/energy</a>
Industrial	<a href="http://www.ti.com/industrial">www.ti.com/industrial</a>
Medical	<a href="http://www.ti.com/medical">www.ti.com/medical</a>
Security	<a href="http://www.ti.com/security">www.ti.com/security</a>
Space, Avionics and Defense	<a href="http://www.ti.com/space-avionics-defense">www.ti.com/space-avionics-defense</a>
Video and Imaging	<a href="http://www.ti.com/video">www.ti.com/video</a>

### TI E2E Community

[e2e.ti.com](http://e2e.ti.com)