

Optimizing Transient Response of Internally Compensated dc-dc Converters With Feedforward Capacitor

Brian Butterfield

PMP - Portable Power

ABSTRACT

This application report describes how to choose the feedforward capacitor value (C_{ff}) of internally compensated dc-dc power supplies to achieve optimum transient response. The described procedure in this application report provides guidance in optimizing transient response by increasing converter bandwidth while retaining acceptable phase margin. This document is intended for all power supply designers who want to optimize the transient response of a working, internally compensated dc-dc converter.

Contents

1	Introduction	1
2	Feedback Network With and Without the Feedforward Capacitor	2
3	Conclusion	11
4	References	11

List of Figures

1	Feedback Network Consisting of Two Bias Resistors Used to Set Output Voltage	2
2	Standard Feedback Divider Transfer Function	2
3	Feedback Network With Addition of Feedforward Capacitor	3
4	Standard Feedback Divider With Feedforward Capacitor Transfer Function.....	3
5	Internally Compensated Converter Without Feedforward Capacitor.....	4
6	Tip and Barrel Measurement Technique	5
7	Voltage Transient in Response to Load Transient Without Feedforward Capacitor	5
8	Step Response vs Loop Phase Margin	6
9	Loop Gain and Phase Plot of TPS61081 Circuit Without Feedforward Capacitor	6
10	Voltage Transient in Response to a Load Transient With 82-pF Feedforward Capacitor	8
11	Loop Gain and Phase Plot of TPS61081 Circuit With 82-pF Feedforward Capacitor	8
12	Voltage Transient in Response to a 0 to 100% Load Transient With 1000-pF Feedforward Capacitor.....	9
13	Loop Gain and Phase Plot of TPS61081 Circuit With 1000-pF Feedforward Capacitor ..	9
14	Voltage Transient in Response to Load Transient With 33-pF Feedforward Capacitor .	10
15	Loop Gain and Phase Plot of TPS61081 Circuit With 33-pF Feedforward Capacitor ...	10

1 Introduction

Internally compensated dc-dc converters allow designers to save time in the design and in debug processes by minimizing the number of external components that they must select. This simplification inherently narrows a designer's ability to optimize the transient response of the converter. However, with some internally compensated converters, the use of a feedforward capacitor in the feedback network is recommended, but only general guidance is provided for choosing this capacitor value to improve

transient response. With measured transient or loop characteristics of a working dc-dc converter, a feedforward capacitor value can be chosen such that the converter bandwidth is significantly improved while still maintaining adequate phase margin. Furthermore, with a better understanding of the feedforward capacitor, the designer can go one step further to optimize either higher bandwidth or greater phase margin to meet specific performance requirements.

2 Feedback Network With and Without the Feedforward Capacitor

Without a feedforward capacitor, the feedback network of an internally compensated dc-dc converter consists of two feedback resistors used to set the output voltage of the converter, as shown in Figure 1. Figure 2 shows the corresponding gain and phase plot.

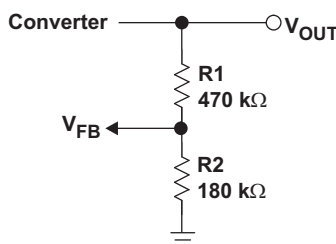

Figure 1. Feedback Network Consisting of Two Bias Resistors Used to Set Output Voltage

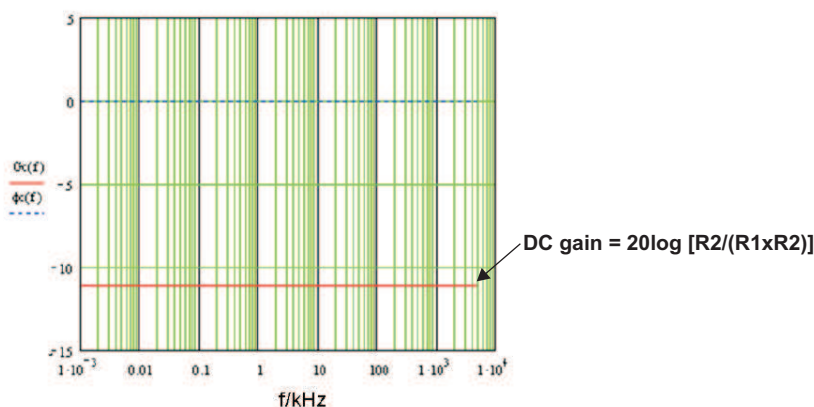

Figure 2. Standard Feedback Divider Transfer Function

Figure 3 shows the addition of the feedforward capacitor, C1 (C_{ff}), in the feedback network and Figure 4 shows the corresponding gain and phase plot. With the addition of the feedforward capacitor network, the converter can more effectively respond to high-frequency disturbances on the output voltage rail. The bode plots in Figure 2 and Figure 4 show that the responses of each feedback network are identical at lower frequencies. At mid-to-higher frequencies, disturbances on the output rail are attenuated less as the impedance path through C1 decreases and effectively provides a boost in gain and phase. In a working power supply, the increased gain and phase correlates to the converter responding faster to transient loads because the voltage deviation, sensed at the feedback node, is attenuated less at higher frequencies. The converter reacts by adjusting the duty cycle to more quickly correct the output voltage deviation.

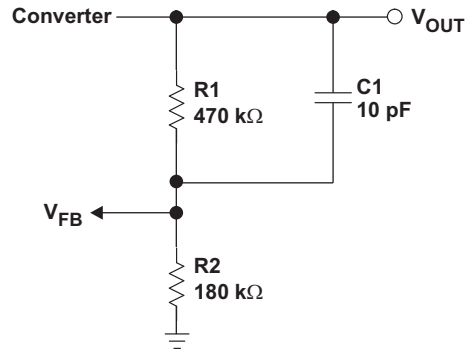

Figure 3. Feedback Network With Addition of Feedforward Capacitor

Although C_{ff} introduces a gain boost after its zero frequency, loop phase boost is at a maximum between the zero and pole frequencies; see the following [Equation 1](#) and [Equation 2](#). Increasing the value of C_{ff} shifts the zero and pole in [Equation 1](#) to lower frequencies, and decreasing the value C_{ff} shifts the zero and pole to higher frequencies. The gain at dc is set by $R1$ and $R2$. The following equations calculate the pole, zero, and the dc gain of the feedback network as is shown in [Figure 4](#).

$$f_z = \frac{1}{2\pi \times R1 \times C_{ff}} \quad (1)$$

[Equation 1](#) calculates the zero frequency based on the feedforward capacitor value and the top bias resistor, $R1$. f_z is shown on the plot in [Figure 4](#).

$$f_p = \frac{1}{2\pi \times C_{ff} \left(\frac{1}{R2} + \frac{1}{R1} \right)} \quad (2)$$

[Equation 2](#) calculates the pole frequency based on the feedforward capacitor value and both top and bottom bias resistors, $R1$ and $R2$. f_p is shown in on the plot in [Figure 4](#).

The transfer function is plotted as:

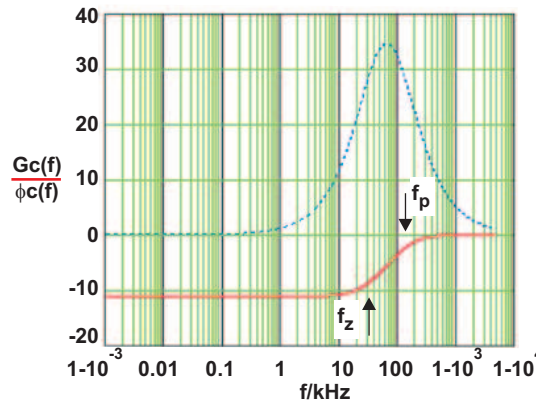

Figure 4. Standard Feedback Divider With Feedforward Capacitor Transfer Function

To optimize transient response, a C_{ff} value is chosen such that the gain and phase boost of the feedback increases the bandwidth of the converter, while still maintaining an acceptable phase margin. In general, larger values of C_{ff} provide greater bandwidth improvements. However, if C_{ff} is too large, the feedforward capacitor causes the loop gain to crossover too high in frequency and the C_{ff} phase boost contribution is insufficient, resulting in unacceptable phase margin or instability. Recommended limitations of C_{ff} is discussed later in this document.

2.1 Feedforward Capacitor Value Optimization Process

The following process outlines a step-by-step procedure for optimizing the feedforward capacitor.

1. Determine the crossover frequency of an internally compensated dc-dc converter with an unpopulated feedforward capacitor (f_{nocff}). In certain circumstance, this can be calculated, but for this application report, this optimization procedure is based on measured converter characteristics. You can determine the crossover frequency (converter bandwidth) with transient analysis or by using a network analyzer. Both methods are shown.
2. Once the crossover frequency is known, a few equations allow calculation of a feedforward capacitor value which prompts a good compromise between bandwidth improvement and acceptable phase margin. Improvement in transient and loop response is shown with transient analysis and frequency analysis to confirm the design.
3. If the designer chooses to optimize for higher bandwidth or increased phase margin (more damping), guidance is provided.

2.2 Determining the Crossover Frequency

The TPS61081 is used in this example to determine the crossover frequency. This example can be applied to other internally compensated dc-dc converters which recommend external feedforward capacitors in the feedback network.

After using the data sheet guidelines to choose all appropriate external components, remove the feedforward capacitor, and measure the converters crossover frequency by using transient analysis or a network analyzer. Note that to determine the crossover frequency, f_{nocff} , the feedforward capacitor must be left open as shown in [Figure 5](#).

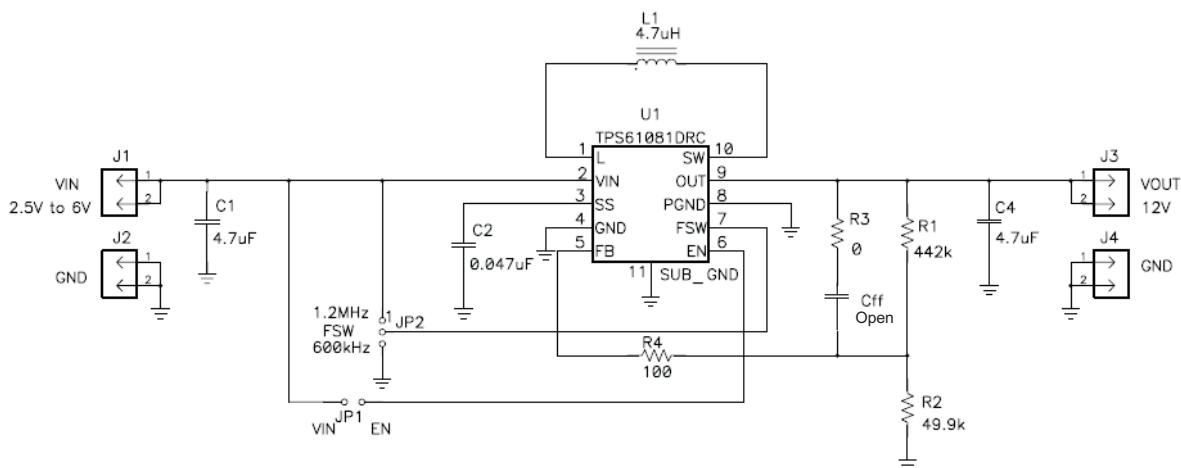

Figure 5. Internally Compensated Converter Without Feedforward Capacitor

[Figure 6](#) shows the tip and barrel measurement method set up for transient analysis. A transient load is connected to the output of the power supply circuit, while a current probe measures the transient load current, and a tip and barrel voltage probe measures the voltage deviation during transient load conditions on the output.

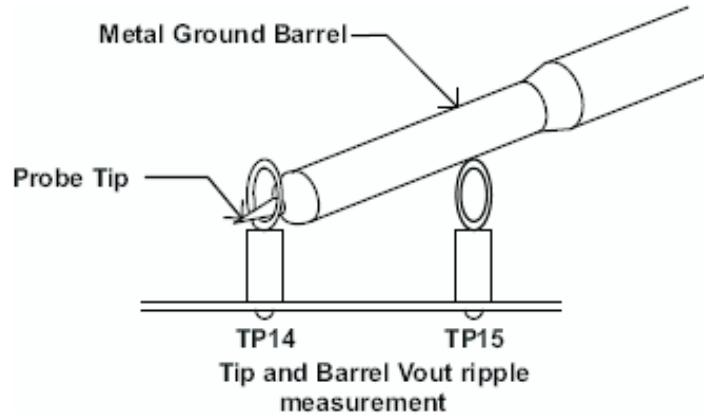

Figure 6. Tip and Barrel Measurement Technique

The tip and barrel measurement technique in [Figure 6](#) is used to minimize coupling magnetic fields and obtain a more accurate voltage waveform during transient load transitions. TP14 is connected to the measured signal whereas TP15 is connected to ground. TP14 and TP15 are not shown in [Figure 5](#). If the power supply does not include the appropriate test points, the test points can be strategically placed using bus wire. It is recommended that the bus wire test points be tacked onto the converter output capacitor closest to the load. [Figure 7](#) shows the TPS61081 transient response as measured with the tip and barrel technique. The plots are taken using the TPS61081EVM-147 with $V_{in} = 5\text{ V}$, $V_{out} = 12\text{ V}$, and a load transient from 0 mA to 160 mA.

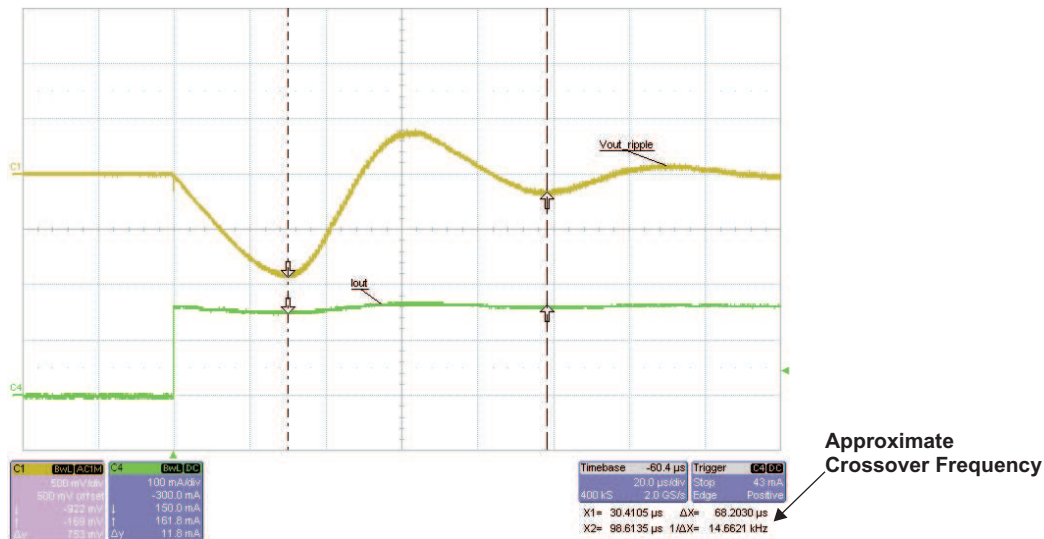

Figure 7. Voltage Transient in Response to Load Transient Without Feedforward Capacitor

About 0.9 V of output voltage deviation from the dc voltage set point is observed. The voltage waveform in [Figure 7](#) provides insight to the converter crossover frequency as described in [Evaluation and Performance Optimization of Fully Integrated DC/DC Converters](#) (Topic 7 of the 2006 Portable Power Design Seminar). The frequency of the voltage deviation waveform in response to a load transient is related to the crossover frequency of the converter. Using the oscilloscope's cursors, the crossover frequency is approximated. The frequency of the transient ripple in this example is approximately 15 kHz. Note that the voltage deviation begins to correct 30 μs after the transient occurs. As the crossover frequency of the converter is increased, it is confirmed that the converter response is improved as the voltage deviation begins to correct in less time, resulting in less voltage deviation.

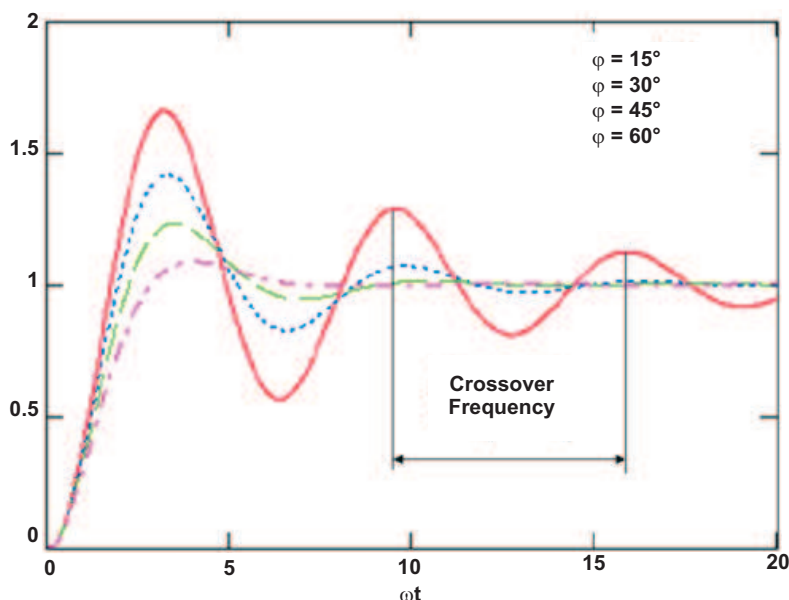

Figure 8. Step Response vs Loop Phase Margin

Using Figure 8 from the 2006 Portable Power Design Seminar topic paper *Evaluation and Performance Optimization of Fully Integrated DC/DC Converters*, the phase margin of the loop can be adequately approximated. Comparing the two plots, the TPS61081 measured the transient response most resembling the number of oscillations of the blue trace with just slightly more oscillation. This means that the measured loop has just slightly less than 30° of phase margin.

2.3 Determining the Crossover Frequency Using Frequency Analysis

Because frequency analysis equipment is costly, using such equipment is not always an option. However, when such equipment is available, the crossover frequency can be quickly measured. This method is more accurate than the transient analysis approximation and should be used when possible. Figure 9 shows the frequency analysis of the control loop for the example circuit in Figure 5.

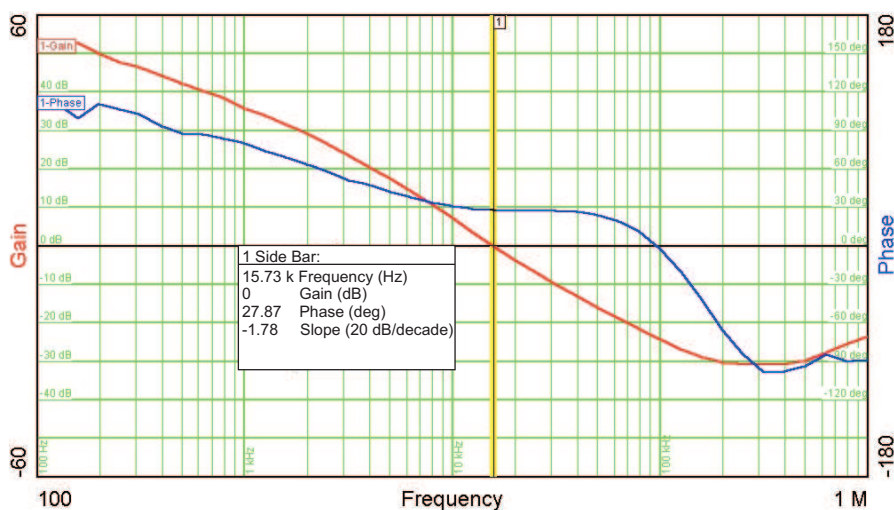

Figure 9. Loop Gain and Phase Plot of TPS61081 Circuit Without Feedforward Capacitor

Once the loop gain and phase plot is obtained with a network analyzer, the crossover frequency is quickly noted. The phase margin is 28° which confirms the transient analysis approximation of being just less than 30°. The crossover frequency also is measured at 16 kHz which is close to the 15-kHz approximation.

2.4 Calculating the Feedforward Capacitor for Optimum Loop Response

With the crossover frequency with no Cff identified (f_{nocff}), the value of Cff can be calculated for optimum transient response by choosing Cff such that the zero and pole frequency geometrically straddle f_{nocff} .

$$f_{\text{nocff}} = 16 \text{ kHz} \quad \text{Converter crossover frequency with no Cff}$$

$$R1 = 442 \text{ k}\Omega \quad R2 = 49.9 \text{ k}\Omega$$

R1 and R2 are the feedback bias resistors used to set the output voltage of the converter as shown in Figure 5.

Equation 3 calculates the geometric mean of the feedback network's zero and pole frequencies. The geometric mean frequency equation is used to calculate the frequency where the phase boost from the zero and pole is at a maximum. However, because Cff is currently unknown, equations f_z and f_p are left in variable form.

$$F_{\text{geometric_mean}} = \sqrt{(f_z \times f_p)} \quad (3)$$

Equation 4 sets the geometric mean frequency equal to the converter crossover frequency with no Cff.

$$f_{\text{noCff}} = \sqrt{(f_z \times f_p)} \quad (4)$$

Setting the geometric mean frequency equal to the converter crossover frequency with no Cff positions the maximum phase boost of Cff at f_{nocff} . However, because Cff introduces a boost in phase and in gain, the new crossover frequency occurs at a frequency greater than the geometric mean frequency. Therefore, the new converter crossover frequency does not occur at the maximum phase boost frequency due to Cff, but crosses over at a higher frequency facilitating a faster converter response time, while still benefitting from additional phase boost. The following plots confirm that the converter response time does indeed improve, and as a result, less transient voltage deviation is observed.

Substituting Equation 1 and Equation 2 into Equation 4 results in Equation 5, which is now a function of R1, R2, and Cff.

$$f_{\text{noCff}} = \sqrt{\left(\frac{1}{2\pi \times R1 \times Cff}\right) \left[\frac{1}{2\pi \times Cff} \left(\frac{1}{R2} + \frac{1}{R1}\right)\right]} \quad (5)$$

Solving for Cff results in a feedforward capacitor value for optimum transient response, Cff_{op}.

$$Cff_{\text{op}} = \frac{1}{2\pi \times f_{\text{nocff}}} \times \sqrt{\frac{1}{R1} \times \left(\frac{1}{R1} + \frac{1}{R2}\right)} \quad (6)$$

Where $f_{\text{nocff}} = 16 \text{ kHz}$, $R1 = 442 \text{ kHz}$, and $R2 = 49.9 \text{ kHz}$. Rounding the calculated Cff value up to the next nearest standard capacitor value, rounds to 82 pF.

$$Cff_{\text{std}} = 82 \text{ pF}$$

2.5 Improvement

Figure 10 shows the improved transient response with the addition of the 82-pF Cff capacitor. The converter responds in 14 μs with Cff = 82 pF compared to 30 μs without Cff. The maximum transient voltage deviation is 377 mV with Cff compared to 900 mV without Cff.

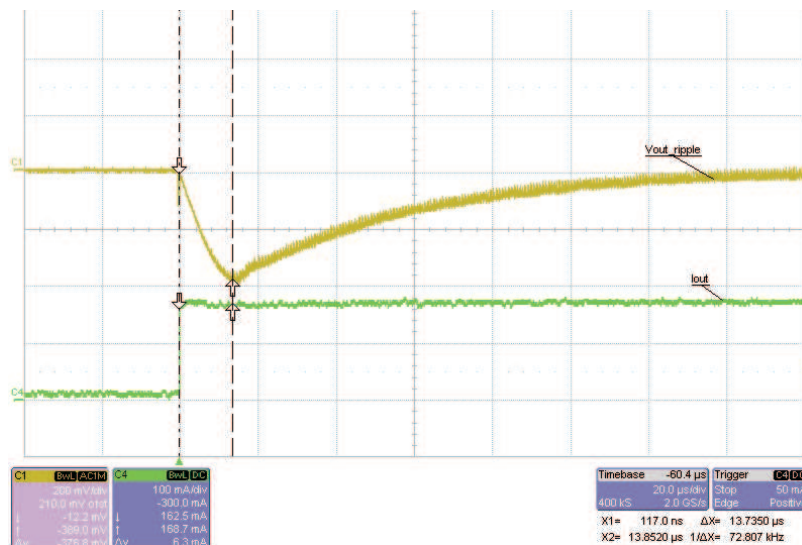

Figure 10. Voltage Transient in Response to a Load Transient With 82-pF Feedforward Capacitor

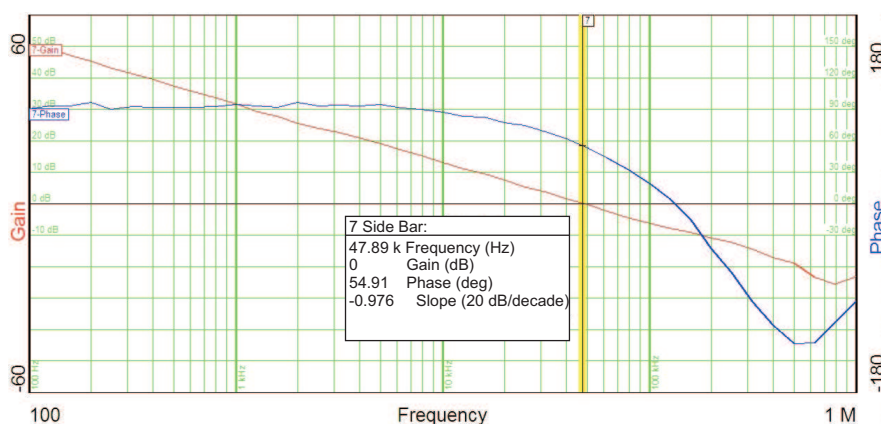

Figure 11. Loop Gain and Phase Plot of TPS61081 Circuit With 82-pF Feedforward Capacitor

Figure 11 shows that the network analyzer also confirms the improved bandwidth with adequate phase margin. For this example, the addition of the C_{ff} capacitor increased the bandwidth by a factor of 3, from 16 kHz to 48 kHz, and increased the phase margin to an acceptable 55°.

For most applications, this is an optimum placement of the feedforward capacitor response. Increasing the feedforward capacitance value pushes both the zero and pole frequencies closer to the origin which increases the crossover frequency but can result in lower overall phase margin. This corresponds to a faster loop at the expense of lower phase margin. Decreasing the C_{ff} value results in the opposite result until a certain point where the feedforward capacitor gain and phase boost contribution diminishes and approaches the response of having no C_{ff}. Having too small a C_{ff} value injects a zero and pole at frequencies too high and effectively too late in loop response, resulting in little or no performance improvement

2.6 Optimizing Toward a Faster Loop At the Expense of Less Phase Margin

To reduce transient ripple even more, the feedforward capacitor value can be increased to push the crossover to higher frequencies. Although this can decrease the voltage deviation even more and speed up loop response, more ringing is observed because less phase boost is added from the feedforward capacitor at the new crossover frequency. Larger C_{ff} values provide less phase boost because increasing

C_{ff} causes the converter to cross over at higher frequencies while the maximum phase boost moves to lower frequencies. It is recommended to keep the feedforward capacitor value smaller than the value which corresponds to 30° of phase margin, so that a phase margin $\geq 30^\circ$ is the minimum phase margin target. This corresponding C_{ff} value limit must be determined empirically, if required. It is generally not recommended to increase C_{ff} significantly greater than the calculated optimized C_{ff} .

Figure 12 and Figure 13 show the same converter using a 1000-pF feedforward capacitor which is much larger than the initially optimized capacitor value in an attempt to speed up the loop response. It is seen that the converter begins to correct the deviation from dc faster and results in less voltage deviation, at 258 mV. Using the network analyzer, the resulting crossover frequency is improved from 48 kHz to 73 kHz at the expense of lower phase margin, now at 22° , which is lower than that generally recommended. In this transient response, the voltage deviation begins to correct in $9\ \mu\text{s}$ as opposed to the optimized $14\text{-}\mu\text{s}$ response.

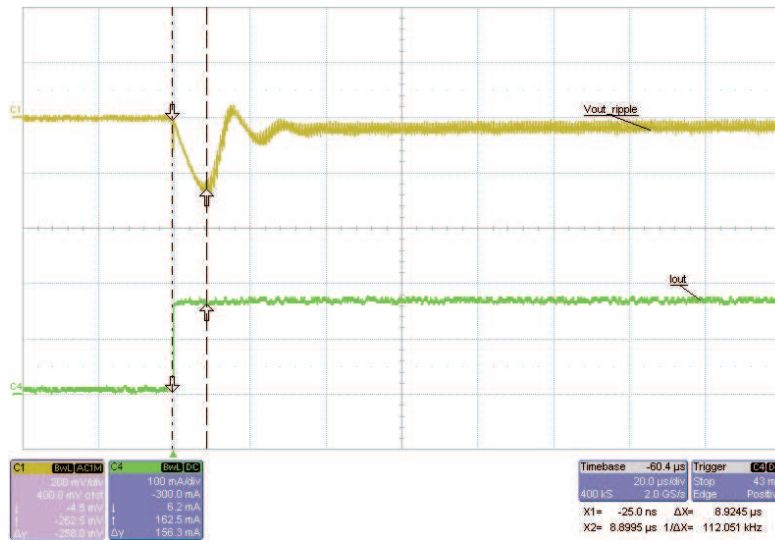

Figure 12. Voltage Transient in Response to a 0 to 100% Load Transient With 1000-pF Feedforward Capacitor

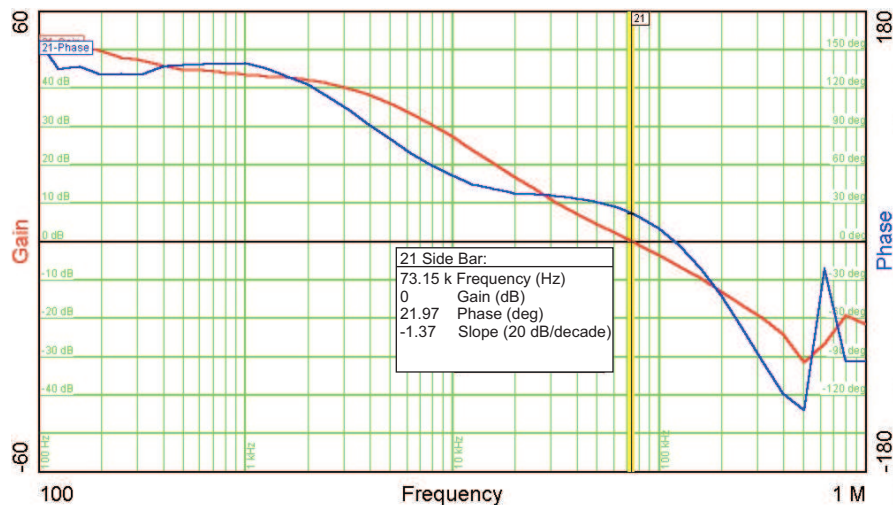

Figure 13. Loop Gain and Phase Plot of TPS61081 Circuit With 1000-pF Feedforward Capacitor

2.7 Optimizing Toward Greater Phase Margin for Less Ringing

Conversely, if more phase margin is desired, a smaller feedforward capacitor allows the loop to crossover at a lower frequency and position the maximum phase boost from the feedforward capacitor closer to the new crossover frequency, with the tradeoff of lower bandwidth. As the Cff capacitor value is reduced, the bandwidth of the converter approaches the bandwidth of the converter without the feedforward capacitor. [Figure 14](#) and [Figure 15](#) show the transient and loop response of a converter with the 82-pF Cff replaced with a 33-pF Cff. With only 33 pF, the converters response time has increased to 22 μ s, resulting in a larger transient voltage deviation of 613 mV. This, however, is still better than the 30- μ s response, 900-mV voltage deviation of the converter without the feedforward capacitor. Also, note that a 0-A to full-load transient is very aggressive testing and was used to show more clearly the optimization throughout this application report.

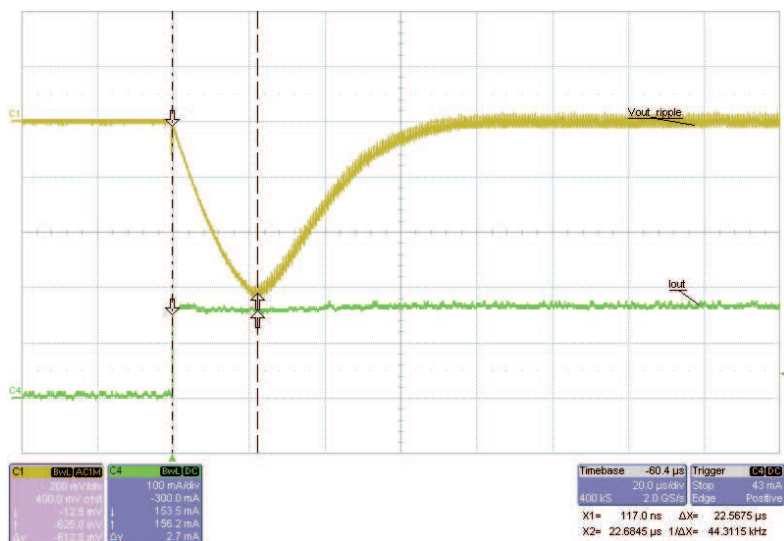

Figure 14. Voltage Transient in Response to Load Transient With 33-pF Feedforward Capacitor

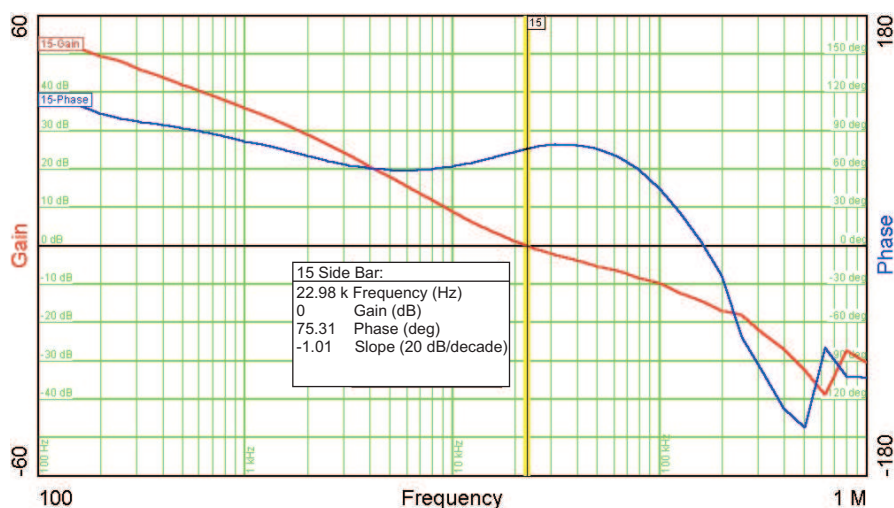

Figure 15. Loop Gain and Phase Plot of TPS61081 Circuit With 33-pF Feedforward Capacitor

3 Conclusion

The feedforward capacitor used in the feedback network improves the performance of internally compensated dc-dc converters. The respective data sheet describes how to generally size the feedforward capacitor for improved loop response. However, with measured response characteristics of a working design, the feedforward capacitor can be sized to facilitate an improved transient response. The calculated optimal C_{ff} value can be increased or decreased to optimize the converters transient response for minimum voltage deviation or higher phase margin.

4 References

1. *Evaluation and Performance Optimization of Fully Integrated DC/DC Converters* (Topic 7 of [2006 Portable Power Design Seminar](#))
2. *Using the TPS40040EVM-001: A 12-V Input, 1.8-V Output, 10-A Synchronous Buck Converter User's Guide* ([SLUU266](#))
3. *TPS6108xEVM-147 User's Guide* ([SLVU144](#))
4. *TPS61080/81, High Voltage DC/DC Boost Converter With 0.5-A/1.3-A Integrated Switch* data sheet ([SLVS644](#))

IMPORTANT NOTICE

Texas Instruments Incorporated and its subsidiaries (TI) reserve the right to make corrections, modifications, enhancements, improvements, and other changes to its products and services at any time and to discontinue any product or service without notice. Customers should obtain the latest relevant information before placing orders and should verify that such information is current and complete. All products are sold subject to TI's terms and conditions of sale supplied at the time of order acknowledgment.

TI warrants performance of its hardware products to the specifications applicable at the time of sale in accordance with TI's standard warranty. Testing and other quality control techniques are used to the extent TI deems necessary to support this warranty. Except where mandated by government requirements, testing of all parameters of each product is not necessarily performed.

TI assumes no liability for applications assistance or customer product design. Customers are responsible for their products and applications using TI components. To minimize the risks associated with customer products and applications, customers should provide adequate design and operating safeguards.

TI does not warrant or represent that any license, either express or implied, is granted under any TI patent right, copyright, mask work right, or other TI intellectual property right relating to any combination, machine, or process in which TI products or services are used. Information published by TI regarding third-party products or services does not constitute a license from TI to use such products or services or a warranty or endorsement thereof. Use of such information may require a license from a third party under the patents or other intellectual property of the third party, or a license from TI under the patents or other intellectual property of TI.

Reproduction of TI information in TI data books or data sheets is permissible only if reproduction is without alteration and is accompanied by all associated warranties, conditions, limitations, and notices. Reproduction of this information with alteration is an unfair and deceptive business practice. TI is not responsible or liable for such altered documentation. Information of third parties may be subject to additional restrictions.

Resale of TI products or services with statements different from or beyond the parameters stated by TI for that product or service voids all express and any implied warranties for the associated TI product or service and is an unfair and deceptive business practice. TI is not responsible or liable for any such statements.

TI products are not authorized for use in safety-critical applications (such as life support) where a failure of the TI product would reasonably be expected to cause severe personal injury or death, unless officers of the parties have executed an agreement specifically governing such use. Buyers represent that they have all necessary expertise in the safety and regulatory ramifications of their applications, and acknowledge and agree that they are solely responsible for all legal, regulatory and safety-related requirements concerning their products and any use of TI products in such safety-critical applications, notwithstanding any applications-related information or support that may be provided by TI. Further, Buyers must fully indemnify TI and its representatives against any damages arising out of the use of TI products in such safety-critical applications.

TI products are neither designed nor intended for use in military/aerospace applications or environments unless the TI products are specifically designated by TI as military-grade or "enhanced plastic." Only products designated by TI as military-grade meet military specifications. Buyers acknowledge and agree that any such use of TI products which TI has not designated as military-grade is solely at the Buyer's risk, and that they are solely responsible for compliance with all legal and regulatory requirements in connection with such use.

TI products are neither designed nor intended for use in automotive applications or environments unless the specific TI products are designated by TI as compliant with ISO/TS 16949 requirements. Buyers acknowledge and agree that, if they use any non-designated products in automotive applications, TI will not be responsible for any failure to meet such requirements.

Following are URLs where you can obtain information on other Texas Instruments products and application solutions:

Products

Amplifiers	amplifier.ti.com
Data Converters	dataconverter.ti.com
DSP	dsp.ti.com
Clocks and Timers	www.ti.com/clocks
Interface	interface.ti.com
Logic	logic.ti.com
Power Mgmt	power.ti.com
Microcontrollers	microcontroller.ti.com
RFID	www.ti-rfid.com
RF/IF and ZigBee® Solutions	www.ti.com/lprf

Applications

Audio	www.ti.com/audio
Automotive	www.ti.com/automotive
Broadband	www.ti.com/broadband
Digital Control	www.ti.com/digitalcontrol
Medical	www.ti.com/medical
Military	www.ti.com/military
Optical Networking	www.ti.com/opticalnetwork
Security	www.ti.com/security
Telephony	www.ti.com/telephony
Video & Imaging	www.ti.com/video
Wireless	www.ti.com/wireless

Mailing Address: Texas Instruments, Post Office Box 655303, Dallas, Texas 75265
Copyright 2008, Texas Instruments Incorporated