

## 650 kHz/1.2 MHz, 18.5 V STEP-UP DC-DC CONVERTER

 Check for Samples: [TPS61085](#)

### FEATURES

- 2.3 V to 6 V Input Voltage Range
- 18.5 V Boost Converter With 2.0 A Switch Current
- 650 kHz/1.2 MHz Selectable Switching Frequency
- Adjustable Soft-Start
- Thermal Shutdown
- Undervoltage Lockout
- 8-Pin MSOP Package
- 8-Pin TSSOP Package

### APPLICATIONS

- Handheld Devices
- GPS Receiver
- Digital Still Camera
- Portable Applications
- DSL Modem
- PCMCIA Card
- TFT LCD Bias Supply

### DESCRIPTION

The TPS61085 is a high frequency, high efficiency DC to DC converter with an integrated 2.0 A, 0.13  $\Omega$  power switch capable of providing an output voltage up to 18.5 V. The selectable frequency of 650 kHz or 1.2 MHz allows the use of small external inductors and capacitors and provides fast transient response. The external pin compensation allows optimizing the application for specific conditions. A capacitor connected to the soft-start pin minimizes inrush current at startup.

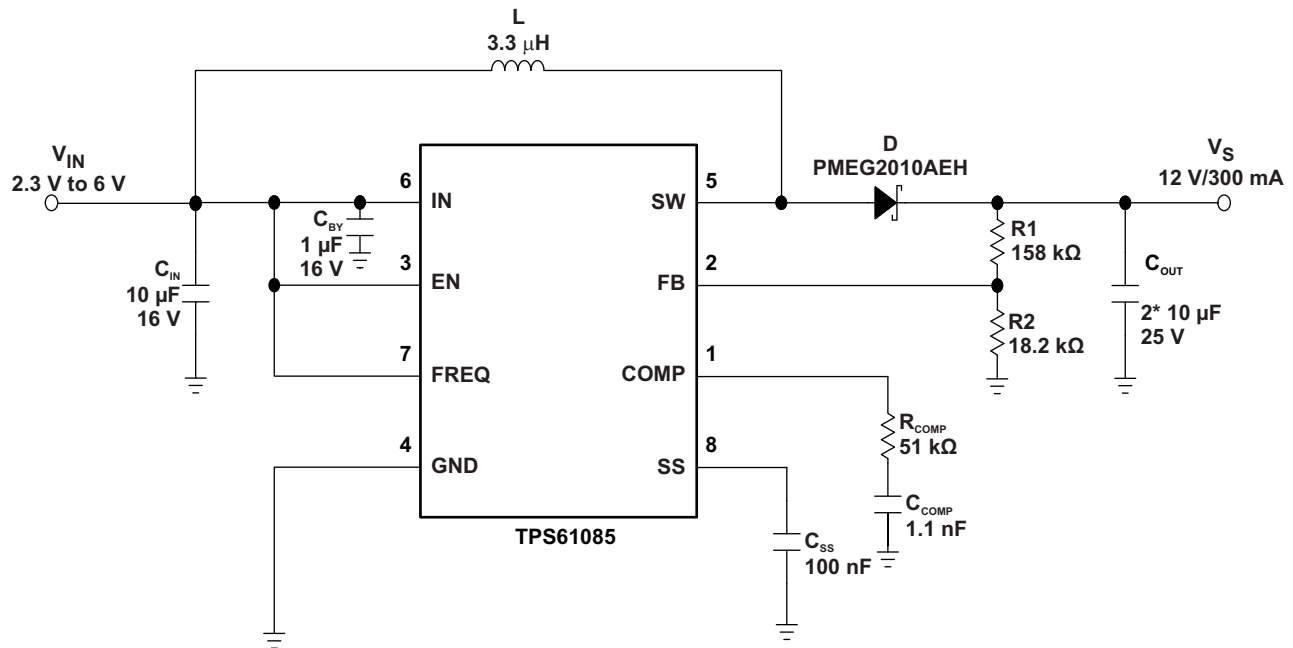

Please be aware that an important notice concerning availability, standard warranty, and use in critical applications of Texas Instruments semiconductor products and disclaimers thereto appears at the end of this data sheet.



These devices have limited built-in ESD protection. The leads should be shorted together or the device placed in conductive foam during storage or handling to prevent electrostatic damage to the MOS gates.

**ORDERING INFORMATION<sup>(1) (2)</sup>**

T <sub>A</sub>	ORDERING	PACKAGE	PACKAGE MARKING
-40 to 85°C	TPS61085DGK	MSOP-8 (DGK)	PMKI
-40 to 85°C	TPS61085PW	TSSOP-8 (PW)	61085

- (1) The DGK and PW packages are available taped and reeled.
- (2) For the most current package and ordering information, see the Package Option Addendum at the end of this document, or see the TI website at www.ti.com.

**ABSOLUTE MAXIMUM RATINGS**

over operating free-air temperature range (unless otherwise noted)<sup>(1)(2)</sup>

	VALUE	UNIT
Input voltage range I <sub>IN</sub>	-0.3 to 7	V
Voltage range on pins EN, FB, SS, FREQ, COMP	-0.3 to 7	V
Voltage on pin SW	-0.3 to 20	V
ESD rating HBM	2	kV
ESD rating MM	200	V
ESD rating CDM	500	V
Continuous power dissipation	See Dissipation Rating Table	
Operating junction temperature range	-40 to 150	°C
Storage temperature range	-65 to 150	°C

- (1) Stresses beyond those listed under *absolute maximum ratings* may cause permanent damage to the device. These are stress ratings only, and functional operation of the device at these or any other conditions beyond those indicated under *recommended operating conditions* is not implied. Exposure to absolute-maximum-rated conditions for extended periods may affect device reliability
- (2) All voltage values are with respect to network ground terminal.

**DISSIPATION RATINGS<sup>(1) (2)</sup>**

PACKAGE	R <sub>θJA</sub>	T <sub>A</sub> ≤ 25°C POWER RATING	T <sub>A</sub> = 70°C POWER RATING	T <sub>A</sub> = 85°C POWER RATING
MSOP	181°C/W	552 mW	303 mW	221 mW
TSSOP	160°C/W	625 mW	343 mW	250 mW

- (1) P<sub>D</sub> = (T<sub>J</sub> - T<sub>A</sub>)/R<sub>θJA</sub>.
- (2) R<sub>θJA</sub> given for High-K PCB board.

**RECOMMENDED OPERATING CONDITIONS**

	MIN	TYP	MAX	UNIT
V <sub>IN</sub> Input voltage range	2.3		6	V
V <sub>S</sub> Boost output voltage range	V <sub>IN</sub> + 0.5		18.5	V
T <sub>A</sub> Operating free-air temperature	-40		85	°C
T <sub>J</sub> Operating junction temperature	-40		125	°C

**ELECTRICAL CHARACTERISTICS**
 $V_{IN} = 3.3\text{ V}$ ,  $EN = V_{IN}$ ,  $V_S = 12\text{ V}$ ,  $T_A = -40^\circ\text{C}$  to  $85^\circ\text{C}$ , typical values are at  $T_A = 25^\circ\text{C}$  (unless otherwise noted)

PARAMETER		TEST CONDITIONS	MIN	TYP	MAX	UNIT
<b>SUPPLY</b>						
$V_{IN}$	Input voltage range		2.3		6	V
$I_Q$	Operating quiescent current into IN	Device not switching, $V_{FB} = 1.3\text{ V}$		70	100	$\mu\text{A}$
$I_{SDVIN}$	Shutdown current into IN	$EN = \text{GND}$			1	$\mu\text{A}$
UVLO	Undervoltage lockout threshold	$V_{IN}$ falling			2.2	V
		$V_{IN}$ rising			2.3	V
$T_{SD}$	Thermal shutdown	Temperature rising		150		$^\circ\text{C}$
$T_{SD(HYS)}$	Thermal shutdown hysteresis			14		$^\circ\text{C}$
<b>LOGIC SIGNALS EN, FREQ</b>						
$V_{IH}$	High level input voltage	$V_{IN} = 2.3\text{ V}$ to $6\text{ V}$	2			V
$V_{IL}$	Low level input voltage	$V_{IN} = 2.3\text{ V}$ to $6\text{ V}$			0.5	V
$I_{lkg}$	Input leakage current	$EN = \text{FREQ} = \text{GND}$			0.1	$\mu\text{A}$
<b>BOOST CONVERTER</b>						
$V_S$	Boost output voltage		$V_{IN} + 0.5$		18.5	V
$V_{FB}$	Feedback regulation voltage		1.230	1.238	1.246	V
gm	Transconductance error amplifier			107		$\mu\text{A/V}$
$I_{FB}$	Feedback input bias current	$V_{FB} = 1.238\text{ V}$			0.1	$\mu\text{A}$
$r_{DS(on)}$	N-channel MOSFET on-resistance	$V_{IN} = V_{GS} = 5\text{ V}$ , $I_{SW} = \text{current limit}$		0.13	0.20	$\Omega$
		$V_{IN} = V_{GS} = 3.3\text{ V}$ , $I_{SW} = \text{current limit}$		0.15	0.24	
$I_{lkg}$	SW leakage current	$EN = \text{GND}$ , $V_{SW} = 6\text{ V TBD}$			10	$\mu\text{A}$
$I_{LIM}$	N-Channel MOSFET current limit		2.0	2.6	3.2	A
$I_{SS}$	Soft-start current	$V_{SS} = 1.238\text{ V}$	7	10	13	$\mu\text{A}$
$f_S$	Oscillator frequency	$\text{FREQ} = V_{IN}$	0.9	1.2	1.5	MHz
		$\text{FREQ} = \text{GND}$	480	650	820	kHz
	Line regulation	$V_{IN} = 2.3\text{ V}$ to $6\text{ V}$ , $I_{OUT} = 10\text{ mA}$		0.0002		%/V
	Load regulation	$V_{IN} = 3.3\text{ V}$ , $I_{OUT} = 1\text{ mA}$ to $400\text{ mA}$		0.11		%/A

### PIN ASSIGNMENT

#### DGK, PW PACKAGES (TOP VIEW)

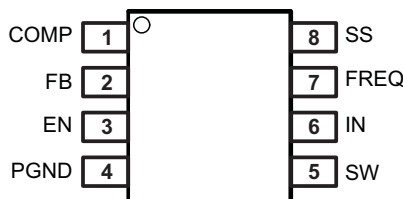

8-PIN 4.9mm x 3mm x 1.1mm MSOP (DGK)  
8-PIN 6.4mm x 3mm x 1.2mm TSSOP (PW)

### PIN FUNCTIONS

PIN		I/O	DESCRIPTION
NAME	NO.		
COMP	1	I/O	Compensation pin
FB	2	I	Feedback pin
EN	3	I	Shutdown control input. Connect this pin to logic high level to enable the device
PGND	4		Power ground
SW	5		Switch pin
IN	6		Input supply pin
FREQ	7	I	Frequency select pin. The power switch operates at 650 kHz if FREQ is connected to GND and at 1.2 MHz if FREQ is connected to IN
SS	8		Soft-start control pin. Connect a capacitor to this pin if soft-start needed. Open = no soft-start

### TYPICAL CHARACTERISTICS

#### TABLE OF GRAPHS

			FIGURE
$I_{OUT(max)}$	Maximum load current	vs Input voltage at high frequency (1.2 MHz)	Figure 1
		vs Input voltage at low frequency (650 kHz)	Figure 2
$\eta$	Efficiency	vs Load current, $V_S = 12\text{ V}$ , $V_{IN} = 3.3\text{ V}$	Figure 3
		vs Load current, $V_S = 9\text{ V}$ , $V_{IN} = 3.3\text{ V}$	Figure 4
	PWM switching - discontinuous conduction		Figure 5
	PWM switching - continuous conduction		Figure 6
	Load transient response	at High frequency (1.2 MHz)	Figure 7
	Load transient response	at Low frequency (650 kHz)	Figure 8
	Soft-start		Figure 9
	Supply current	vs Supply voltage	Figure 10
	Frequency	vs Load current	Figure 11
	Frequency	vs Supply voltage	Figure 12

The typical characteristics are measured with the inductors 7447789003 3.3  $\mu\text{H}$  (high frequency) or B82464G4 6.8  $\mu\text{H}$  (low frequency) from Epcos and the rectifier diode SL22.

MAXIMUM LOAD CURRENT  
vs  
INPUT VOLTAGE

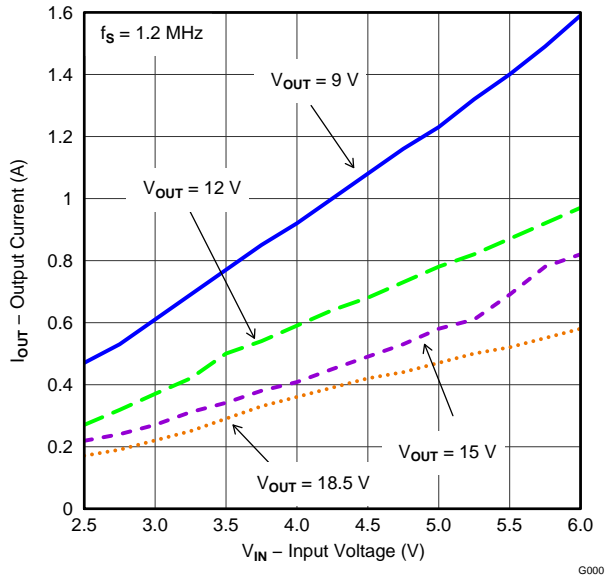

Figure 1.

MAXIMUM LOAD CURRENT  
vs  
INPUT VOLTAGE

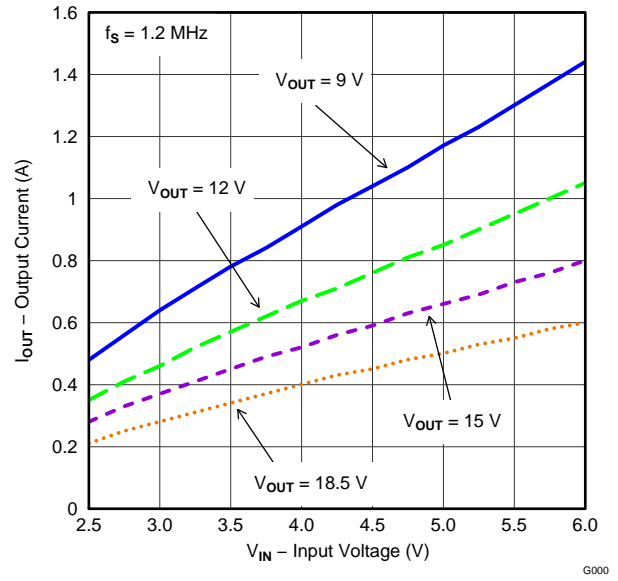

Figure 2.

EFFICIENCY  
vs  
LOAD CURRENT

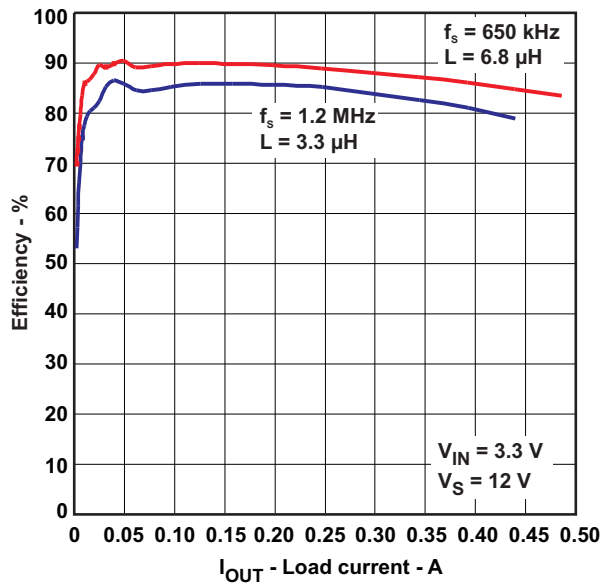

Figure 3.

EFFICIENCY  
vs  
LOAD CURRENT

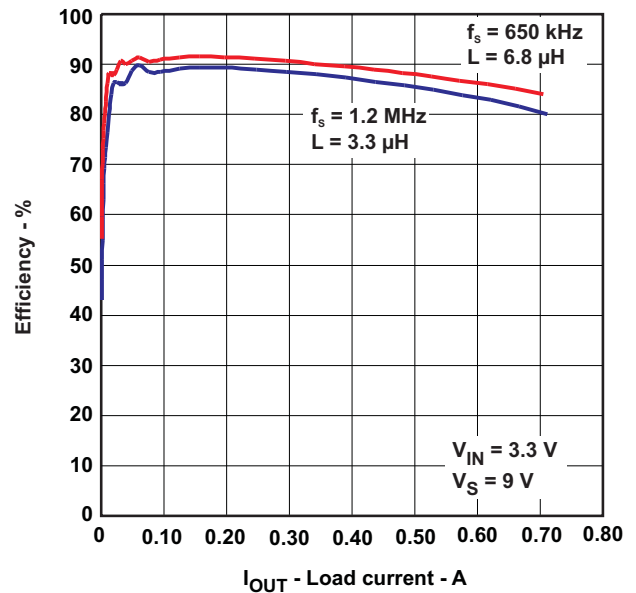

Figure 4.

**PWM SWITCHING  
DISCONTINUOUS CONDUCTION MODE**

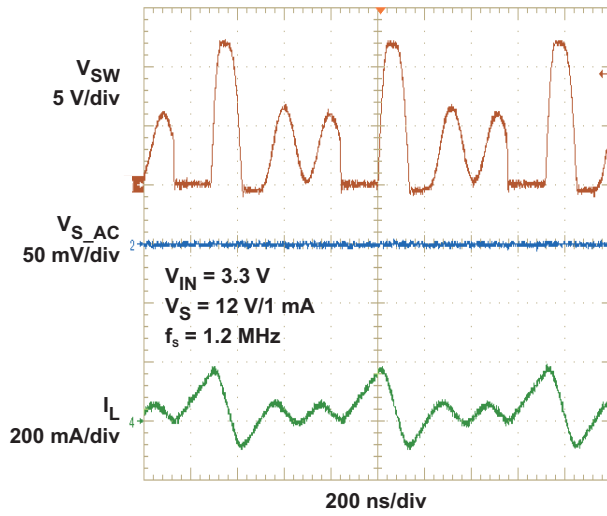

Figure 5.

**PWM SWITCHING  
CONTINUOUS CONDUCTION MODE**

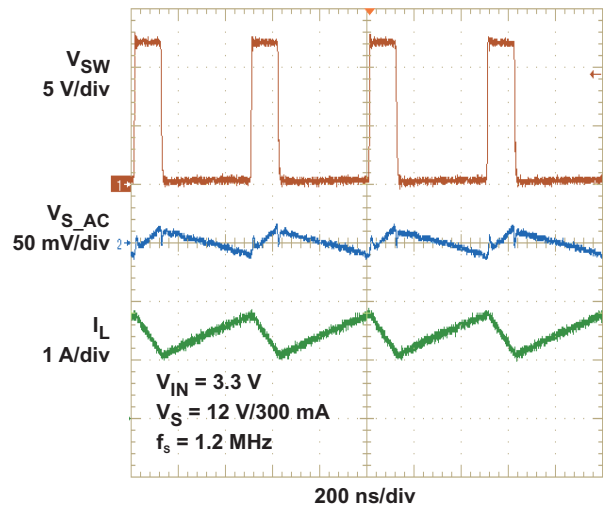

Figure 6.

**LOAD TRANSIENT RESPONSE  
HIGH FREQUENCY (1.2 MHz)**

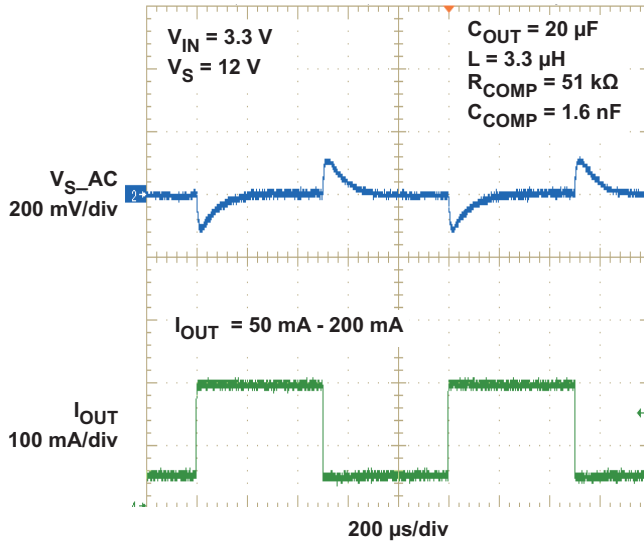

Figure 7.

**LOAD TRANSIENT RESPONSE  
LOW FREQUENCY (650 kHz)**

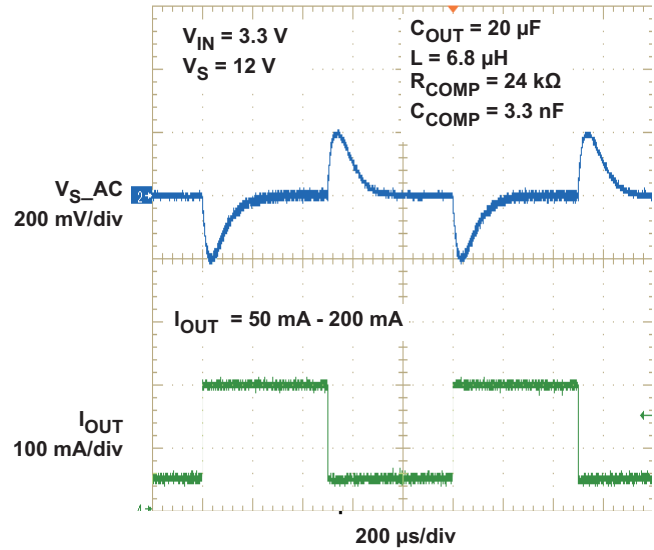

Figure 8.

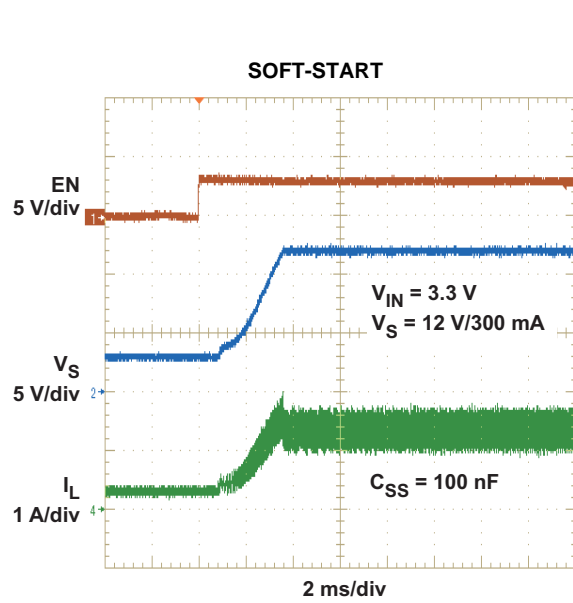

Figure 9.

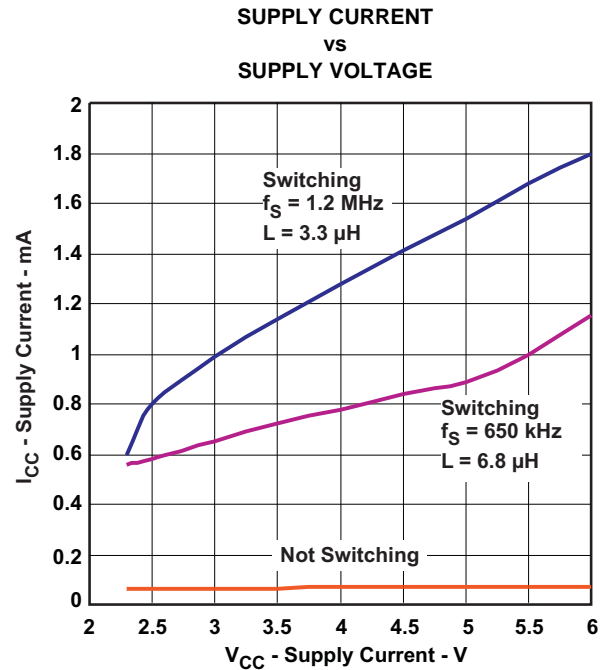

Figure 10.

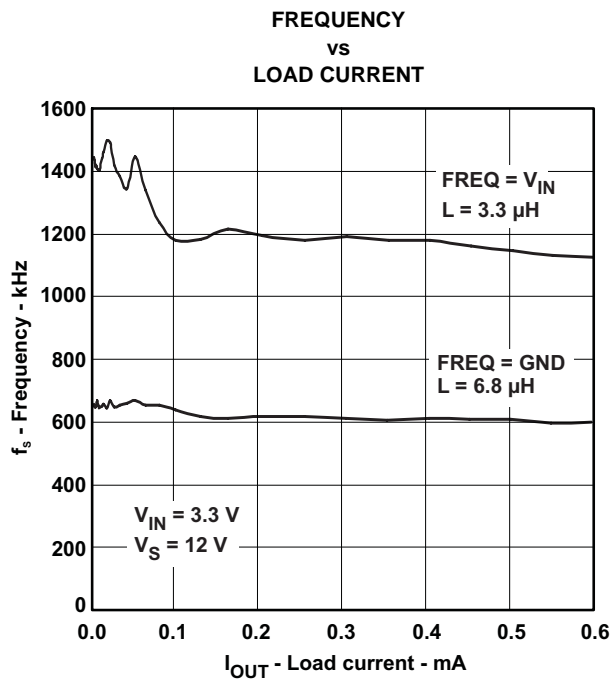

Figure 11.

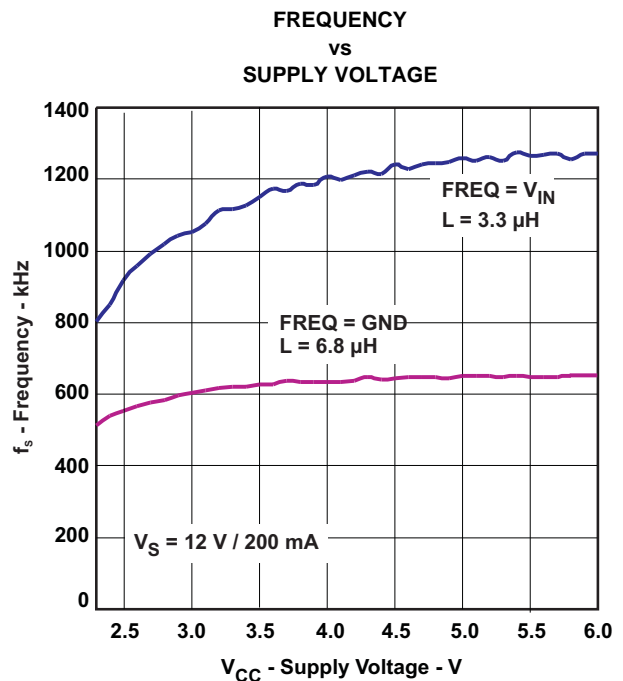

Figure 12.

DETAILED DESCRIPTION

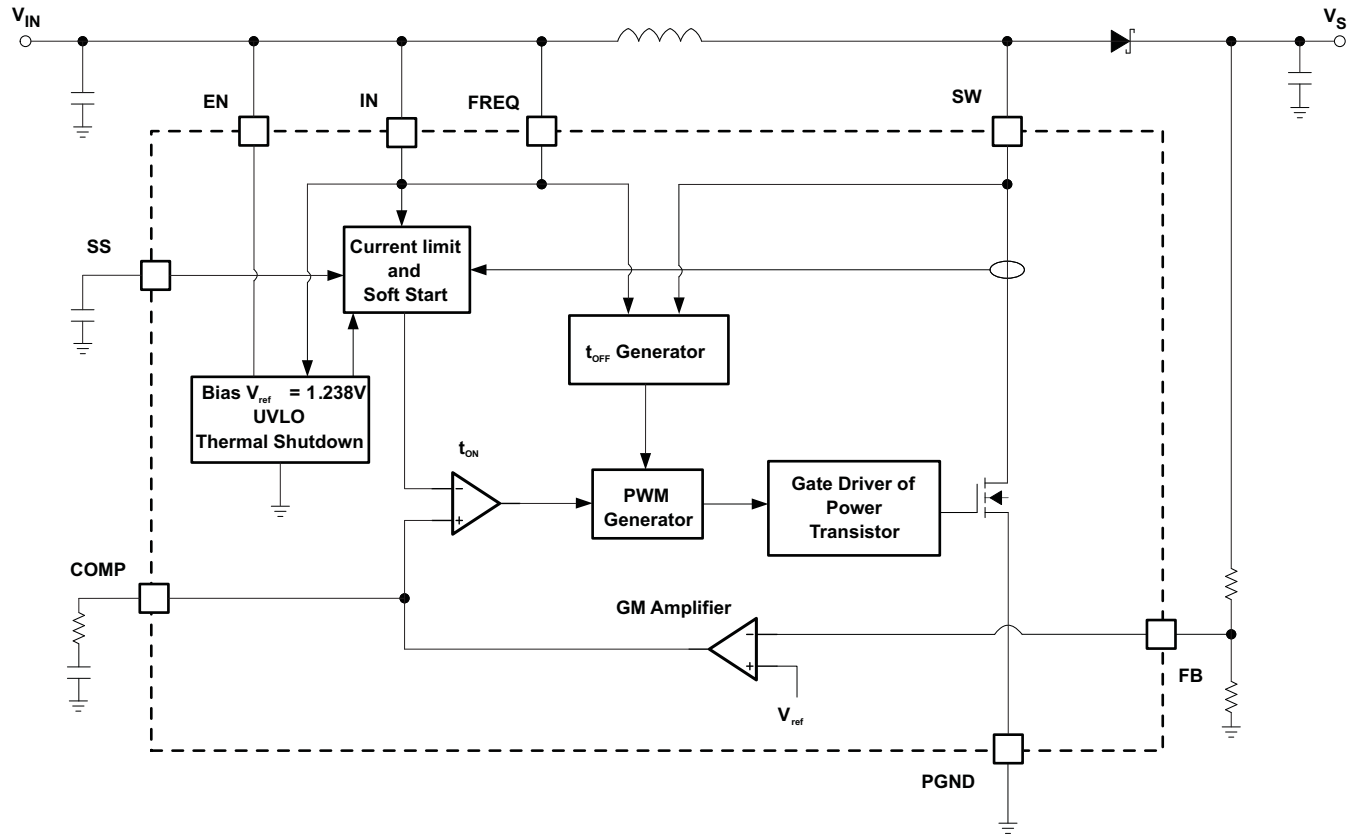

Figure 13. Block Diagram

The boost converter is designed for output voltages up to 18.5 V with a switch peak current limit of 2.0 A minimum. The device, which operates in a current mode scheme with quasi-constant frequency, is externally compensated for maximum flexibility and stability. The switching frequency is selectable between 650 kHz and 1.2 MHz and the minimum input voltage is 2.3 V. To control the inrush current at start-up a soft-start pin is available.

TPS61085 boost converter’s novel topology using adaptive off-time provides superior load and line transient responses and operates also over a wider range of applications than conventional converters.

The selectable switching frequency offers the possibility to optimize the design either for the use of small sized components (1.2 MHz) or for higher system efficiency (650 kHz). However, the frequency changes slightly because the voltage drop across the  $r_{DS(on)}$  has some influence on the current and voltage measurement and thus on the on-time (the off-time remains constant).

The converter operates in continuous conduction mode (CCM) as soon as the input current increases above half the ripple current in the inductor, for lower load currents it switches into discontinuous conduction mode (DCM). If the load is further reduced, the part starts to skip pulses to maintain the output voltage.

## Design Procedure

The first step in the design procedure is to verify that the maximum possible output current of the boost converter supports the specific application requirements. A simple approach is to estimate the converter efficiency, by taking the efficiency numbers from the provided efficiency curves or to use a worst case assumption for the expected efficiency, e.g. 90%.

1. Duty cycle,  $D$ :

$$D = 1 - \frac{V_{IN} \cdot \eta}{V_S} \quad (1)$$

2. Maximum output current,  $I_{OUT(max)}$  :

$$I_{OUT(max)} = \left( I_{LIM(min)} - \frac{\Delta I_L}{2} \right) \cdot (1 - D) \quad (2)$$

3. Peak switch current in application,  $I_{SW(peak)}$  :

$$I_{SW(peak)} = \frac{\Delta I_L}{2} + \frac{I_{OUT}}{1 - D} \quad (3)$$

with the inductor peak-to-peak ripple current,  $\Delta I_L$

$$\Delta I_L = \frac{V_{IN} \cdot D}{f_S \cdot L} \quad (4)$$

and

$V_{IN}$	Minimum input voltage
$V_S$	Output voltage
$I_{LIM(min)}$	Converter switch current limit (minimum switch current limit = 3.2 A)
$f_S$	Converter switching frequency (typically 1.2 MHz or 650 kHz)
$L$	Selected inductor value
$\eta$	Estimated converter efficiency (please use the number from the efficiency plots or 90% as an estimation)

The peak switch current is the steady state peak switch current that the integrated switch, inductor and external Schottky diode has to be able to handle. The calculation must be done for the minimum input voltage where the peak switch current is the highest.

## Soft-start

The boost converter has an adjustable soft-start to prevent high inrush current during start-up. To minimize the inrush current during start-up an external capacitor connected to the soft-start pin SS and charged with a constant current, is used to slowly ramp up the internal current limit of the boost converter when charged with a constant current. When the EN pin is pulled high, the soft-start capacitor  $C_{SS}$  is immediately charged to 0.3 V. The capacitor is then charged at a constant current of 10  $\mu$ A typically until the output of the boost converter  $V_S$  has reached its Power Good threshold (roughly 98% of  $V_S$  nominal value). During this time, the SS voltage directly controls the peak inductor current, starting with 0 A at  $V_{SS} = 0.3$  V up to the full current limit at  $V_{SS} = 0.8$  V. The maximum load current is available after the soft-start is completed. The larger the capacitor the slower the ramp of the current limit and the longer the soft-start time. A 100 nF capacitor is usually sufficient for most of the applications. When the EN pin is pulled low, the soft-start capacitor is discharged to ground.

## Inductor Selection

The TPS61085 is designed to work with a wide range of inductors. The main parameter for the inductor selection is the saturation current of the inductor which should be higher than the peak switch current as calculated in the *Design Procedure* section with additional margin to cover for heavy load transients. An alternative, more conservative, is to choose an inductor with a saturation current at least as high as the maximum switch current limit of 3.2 A. The other important parameter is the inductor dc resistance. Usually, the lower the dc resistance the higher the efficiency. It is important to note that the inductor dc resistance is not the only parameter determining the efficiency. Especially for a boost converter where the inductor is the energy storage element, the type and core material of the inductor influences the efficiency as well. At high switching frequencies of 1.2 MHz inductor core losses, proximity effects and skin effects become more important. Usually, an inductor with a larger form factor gives higher efficiency. The efficiency difference between different inductors can vary between 2% to 10%. For the TPS61085, inductor values between 3  $\mu\text{H}$  and 6  $\mu\text{H}$  are a good choice with a switching frequency of 1.2 MHz, typically 3.3  $\mu\text{H}$ . At 650 kHz inductors between 6  $\mu\text{H}$  and 13  $\mu\text{H}$ , typically 6.8  $\mu\text{H}$  are recommended. Possible inductors are shown in [Table 1](#).

Typically, it is recommended that the inductor current ripple is below 35% of the average inductor current. Therefore, the following equation can be used to calculate the inductor value,  $L$ :

$$L = \left( \frac{V_{IN}}{V_S} \right)^2 \cdot \left( \frac{V_S - V_{IN}}{I_{OUT} \cdot f_S} \right) \cdot \left( \frac{\eta}{0.35} \right) \quad (5)$$

with

$V_{IN}$	Minimum input voltage
$V_S$	Output voltage
$I_{out}$	Maximum output current in the application
$f_S$	Converter switching frequency (typically 1.2 MHz or 650 kHz)
$\eta$	Estimated converter efficiency (please use the number from the efficiency plots or 90% as an estimation)

**Table 1. Inductor Selection**

L ( $\mu\text{H}$ )	SUPPLIER	COMPONENT CODE	SIZE (LxWxH mm)	DCR TYP (m $\Omega$ )	Isat (A)
<b>1.2 MHz</b>					
3.3	Sumida	CDH38D09	4 x 4 x 1	240	1.25
4.7	Sumida	CDPH36D13	5 x 5 x 1.5	155	1.36
3.3	Sumida	CDPH4D19F	5.2 x 5.2 x 2	33	1.5
3.3	Sumida	CDRH6D12	6.7 x 6.7 x 1.5	62	2.2
4.7	Würth Elektronik	7447785004	5.9 x 6.2 x 3.3	60	2.5
5	Coilcraft	MSS7341	7.3 x 7.3 x 4.1	24	2.9
<b>650 kHz</b>					
6.8	Sumida	CDP14D19	5.2 x 5.2 x 2	50	1
10	Coilcraft	LPS4414	4.3 x 4.3 x 1.4	380	1.2
6.8	Sumida	CDRH6D12/LD	6.7 x 6.7 x 1.5	95	1.25
10	Sumida	CDR6D23	5 x 5 x 2.4	133	1.75
10	Würth Elektronik	744778910	7.3 x 7.3 x 3.2	51	2.2
6.8	Sumida	CDRH6D26HP	7 x 7 x 2.8	52	2.9

## Rectifier Diode Selection

To achieve high efficiency, a Schottky type should be used for the rectifier diode. The reverse voltage rating should be higher than the maximum output voltage of the converter. The averaged rectified forward current  $I_{avg}$ , the Schottky diode needs to be rated for, is equal to the output current  $I_{OUT}$ :

$$I_{avg} = I_{OUT} \quad (6)$$

Usually a Schottky diode with 2 A maximum average rectified forward current rating is sufficient for most applications. The Schottky rectifier can be selected with lower forward current capability depending on the output current  $I_{OUT}$  but has to be able to dissipate the power. The dissipated power,  $P_D$ , is the average rectified forward current times the diode forward voltage,  $V_{forward}$ .

$$P_D = I_{avg} \cdot V_{forward} \quad (7)$$

Typically the diode should be able to dissipate around 500mW depending on the load current and forward voltage.

**Table 2. Rectifier Diode Selection**

CURRENT RATING $I_{avg}$	Vr	$V_{forward} / I_{avg}$	SUPPLIER	COMPONENT CODE	PACKAGE TYPE
750 mA	20 V	0.425 V / 750 mA	Fairchild Semiconductor	FYV0704S	SOT 23
1 A	20 V	0.39 V / 1 A	NXP	PMEG2010AEH	SOD 123
1 A	20 V	0.52 V / 1 A	Vishay Semiconductor	B120	SMA
1 A	20 V	0.5 V / 1 A	Vishay Semiconductor	SS12	SMA
1 A	20 V	0.44 V / 1 A	Vishay Semiconductor	MSS1P2L	μ-SMP (Low Profile)

### Setting the Output Voltage

The output voltage is set by an external resistor divider. Typically, a minimum current of 50 μA flowing through the feedback divider gives good accuracy and noise covering. A standard low side resistor of 18 kΩ is typically selected. The resistors are then calculated as:

$$R2 = \frac{V_{FB}}{70\mu A} \approx 18k\Omega \quad R1 = R2 \cdot \left( \frac{V_S}{V_{FB}} - 1 \right)$$

$$V_{FB} = 1.238V$$

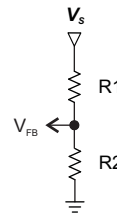

(8)

### Compensation (COMP)

The regulator loop can be compensated by adjusting the external components connected to the COMP pin. The COMP pin is the output of the internal transconductance error amplifier.

Standard values of  $R_{COMP} = 13 k\Omega$  and  $C_{COMP} = 3.3 nF$  will work for the majority of the applications.

See [Table 3](#) for dedicated compensation networks giving an improved load transient response. The following equations can be used to calculate  $R_{COMP}$  and  $C_{COMP}$ :

$$R_{COMP} = \frac{110 \cdot V_{IN} \cdot V_S \cdot C_{OUT}}{L \cdot I_{OUT}} \quad C_{COMP} = \frac{V_S \cdot C_{OUT}}{7.5 \cdot I_{OUT} \cdot R_{COMP}} \quad (9)$$

with

$V_{IN}$	Minimum input voltage
$V_S$	Output voltage
$C_{out}$	Output capacitance
$L$	Inductor value, e.g. 3.3 μH or 6.8 μH
$I_{OUT}$	Maximum output current in the application

Make sure that  $R_{COMP} < 120 k\Omega$  and  $C_{COMP} > 820 pF$ , independent of the results of the above formulas.

**Table 3. Recommended Compensation Network Values at High/Low Frequency**

FREQUENCY	L	V <sub>S</sub>	V <sub>IN</sub> ± 20%	R <sub>COMP</sub>	C <sub>COMP</sub>	Used I <sub>OUT</sub>
High (1.2 MHz)	3.3 µH	15 V	5 V	82 kΩ	1.1 nF	0.7A
			3.3 V	75 kΩ	1.6 nF	0.5A
		12 V	5 V	51 kΩ	1.1 nF	0.9A
			3.3 V	47 kΩ	1.6 nF	0.6A
		9 V	5 V	30 kΩ	1.1 nF	1.2A
			3.3 V	27 kΩ	1.6 nF	0.8A
Low (650 kHz)	6.8 µH	15 V	5 V	43 kΩ	2.2 nF	0.7A
			3.3 V	39 kΩ	3.3 nF	0.5A
		12 V	5 V	27 kΩ	2.2 nF	0.9A
			3.3 V	24 kΩ	3.3 nF	0.6A
		9 V	5 V	15 kΩ	2.2 nF	1.2A
			3.3 V	13 kΩ	3.3 nF	0.8A

Table 3 gives conservative R<sub>COMP</sub> and C<sub>COMP</sub> values for certain inductors, input and output voltages providing a very stable system. For a faster response time, a higher R<sub>COMP</sub> value can be used to enlarge the bandwidth, as well as a slightly lower value of C<sub>COMP</sub> to keep enough phase margin. These adjustments should be performed in parallel with the load transient response monitoring of TPS61087.

### Input Capacitor Selection

For good input voltage filtering low ESR ceramic capacitors are recommended. TPS61085 has an analog input IN. Therefore, a 1 µF bypass is highly recommended as close as possible to the IC from IN to GND.

One 10 µF ceramic input capacitors are sufficient for most of the applications. For better input voltage filtering this value can be increased. Refer to Table 4 and typical applications for input capacitor recommendations.

### Output Capacitor Selection

For best output voltage filtering a low ESR output capacitor like ceramic capacitor is recommended. Two 10 µF ceramic output capacitors (or one 22 µF) work for most of the applications. Higher capacitor values can be used to improve the load transient response. Refer to Table 4 for the selection of the output capacitor.

**Table 4. Rectifier Input and Output Capacitor Selection**

	CAPACITOR	VOLTAGE RATING	SUPPLIER	COMPONENT CODE
C <sub>IN</sub>	10 µF/1206	16 V	Taiyo Yuden	EMK212 BJ 106KG
IN bypass	1 µF/0603	16 V	Taiyo Yuden	EMK107 BJ 105KA
C <sub>OUT</sub>	10 µF/1206	25 V	Taiyo Yuden	TMK316 BJ 106KL

To calculate the output voltage ripple, the following equation can be used:

$$\Delta V_C = \frac{V_S - V_{IN}}{V_S \cdot f_S} \cdot \frac{I_{OUT}}{C_{OUT}} \quad \Delta V_{C\_ESR} = I_{L(peak)} \cdot R_{C\_ESR} \tag{10}$$

with

- ΔV<sub>C</sub> Output voltage ripple dependent on output capacitance, output current and switching frequency
- V<sub>S</sub> Output voltage
- V<sub>IN</sub> Minimum input voltage of boost converter
- f<sub>S</sub> Converter switching frequency (typically 1.2 MHz or 650 kHz)
- I<sub>out</sub> Output capacitance
- ΔV<sub>C\_ESR</sub> Output voltage ripple due to output capacitors ESR (equivalent series resistance)
- I<sub>SWPEAK</sub> Inductor peak switch current in the application
- R<sub>C\_ESR</sub> Output capacitors equivalent series resistance (ESR)

ΔV<sub>C\_ESR</sub> can be neglected in many cases since ceramic capacitors provide low ESR.

### Frequency Select Pin (FREQ)

The frequency select pin FREQ allows to set the switching frequency of the device to 650 kHz (FREQ = low) or 1.2 MHz (FREQ = high). Higher switching frequency improves load transient response but reduces slightly the efficiency. The other benefits of higher switching frequency are a lower output ripple voltage. The use of the 1.2 MHz switching frequency is recommended unless light load efficiency is a major concern.

### Undervoltage Lockout (UVLO)

To avoid mis-operation of the device at low input voltages an undervoltage lockout is included that disables the device, if the input voltage falls below 2.2 V.

### Thermal Shutdown

A thermal shutdown is implemented to prevent damages due to excessive heat and power dissipation. Typically the thermal shutdown threshold happens at a junction temperature of 150°C. When the thermal shutdown is triggered the device stops switching until the temperature falls below typically 136°C. Then the device starts switching again.

### Overvoltage Prevention

If overvoltage is detected on the FB pin (typically 3 % above the nominal value of 1.238 V) the part stops switching immediately until the voltage on this pin drops to its nominal value. This prevents overvoltage on the output and secures the circuits connected to the output from excessive overvoltage.

## APPLICATION INFORMATION

### General Boost Application Circuits

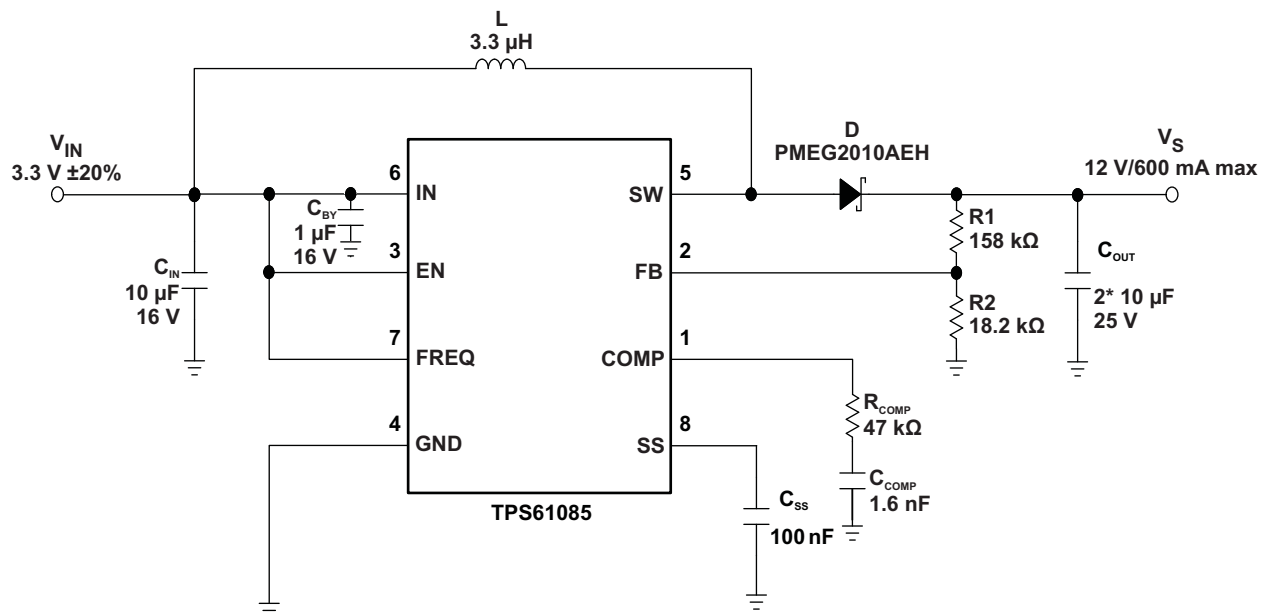

Figure 14. Typical Application, 3.3 V to 12 V ( $f_s = 1.2$  MHz)

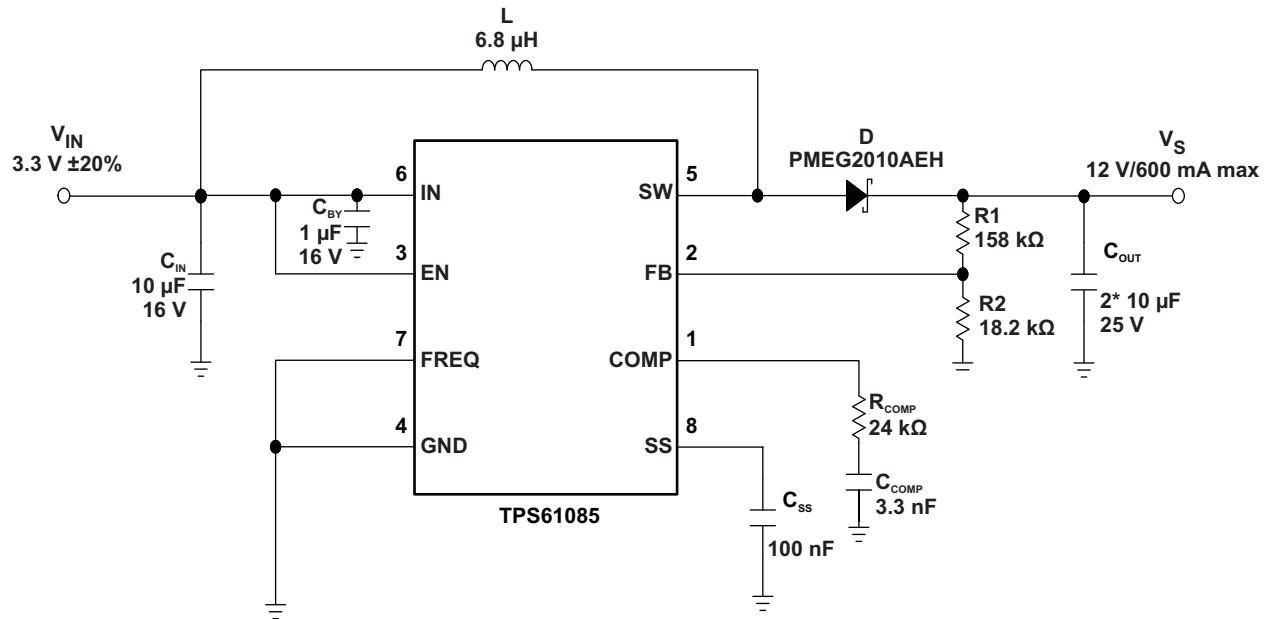

Figure 15. Typical Application, 3.3 V to 12 V ( $f_s = 650$  kHz)

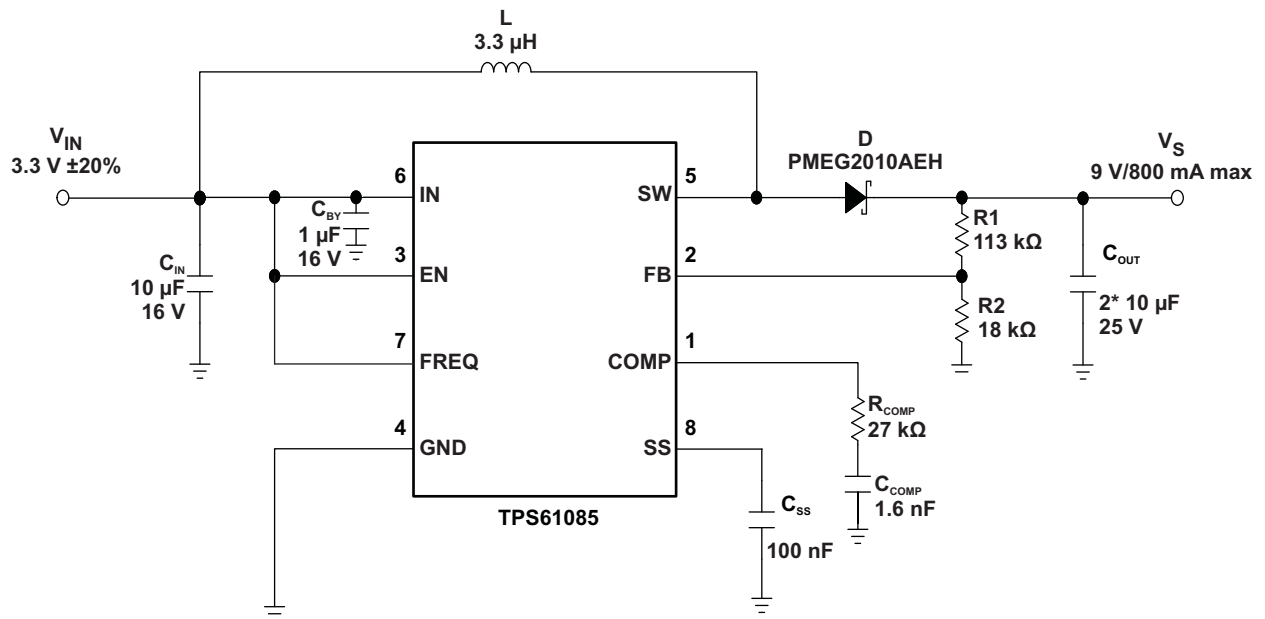

Figure 16. Typical Application, 3.3 V to 9 V ( $f_s = 1.2$  MHz)

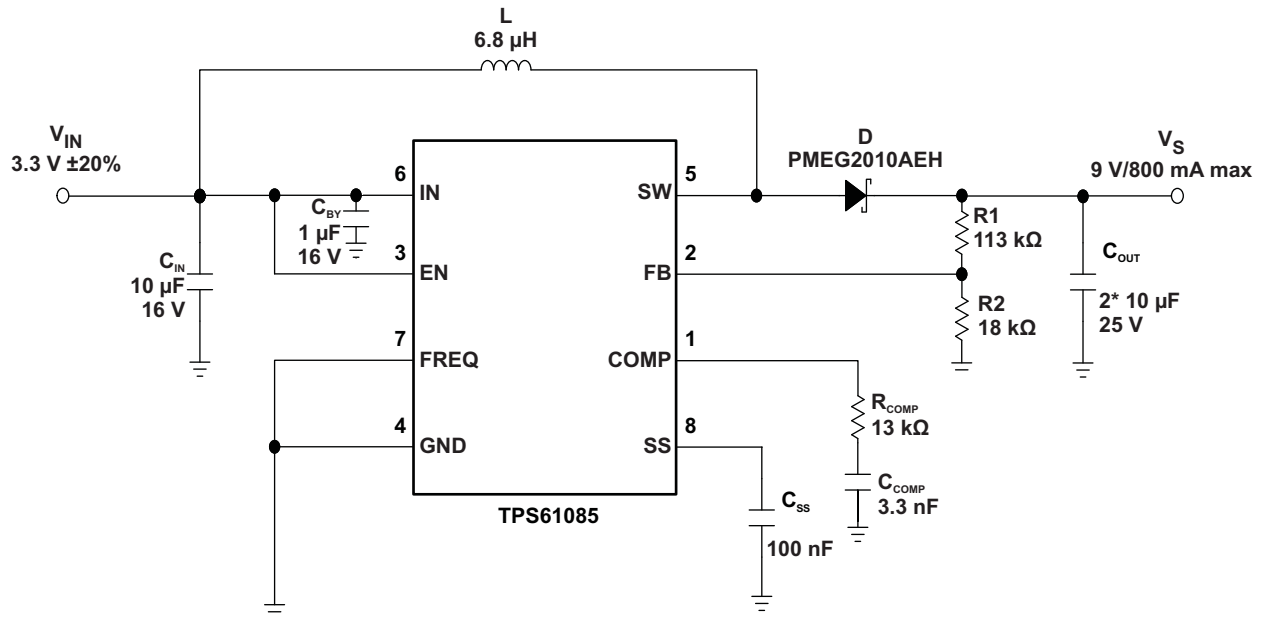

Figure 17. Typical Application, 3.3 V to 9 V ( $f_s = 650\ \text{kHz}$ )

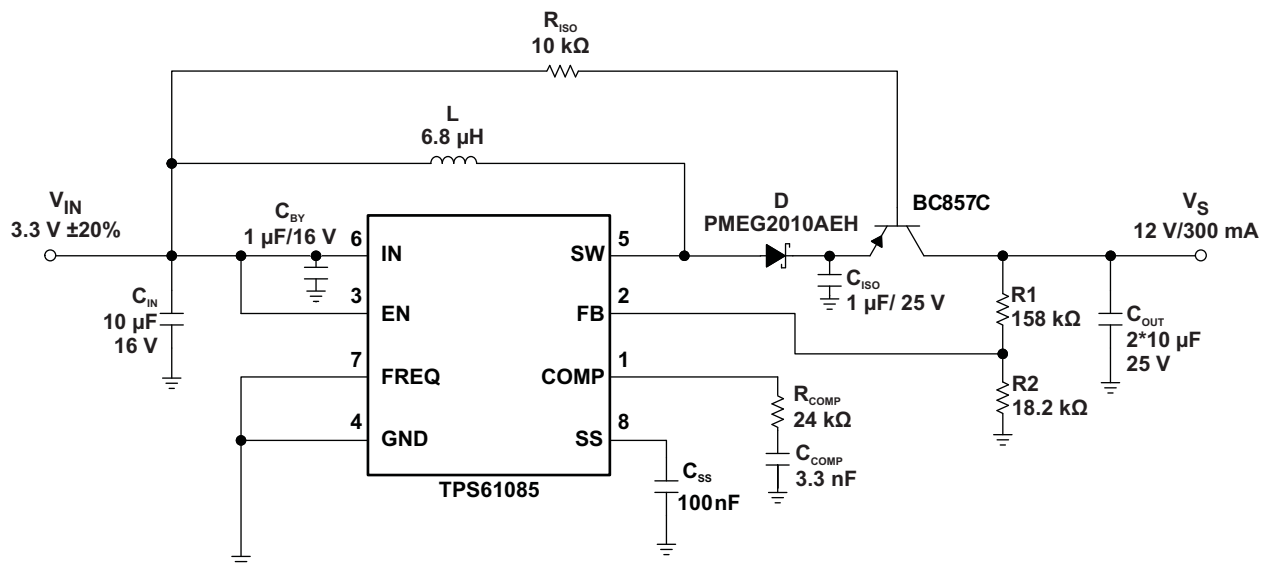

Figure 18. Typical Application with External Load Disconnect Switch

TFT LCD Application Circuit

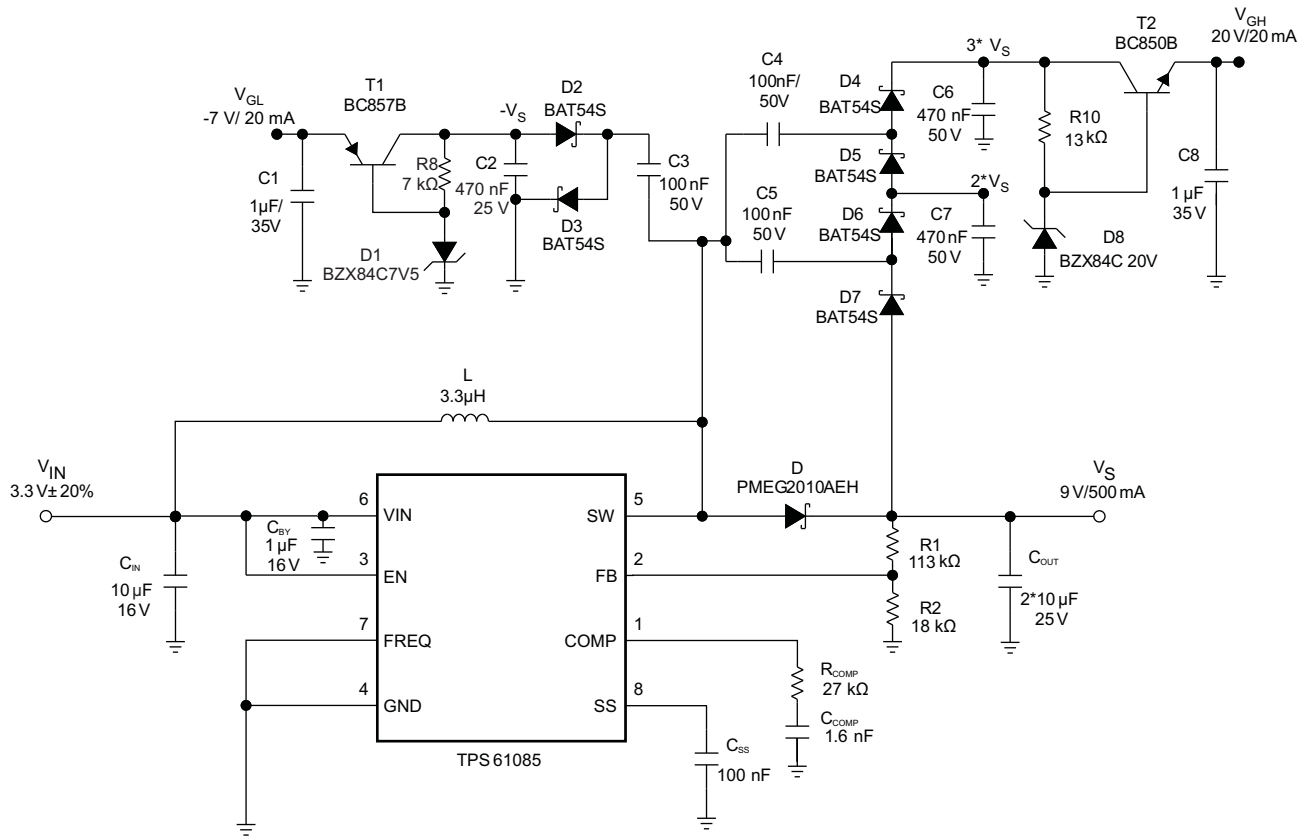

Figure 19. Typical Application 3.3 V to 9 V ( $f_s = 1.2 \text{ MHz}$ ) for TFT LCD with External Charge Pumps (VGH, VGL)

WHITE LED Application Circuits

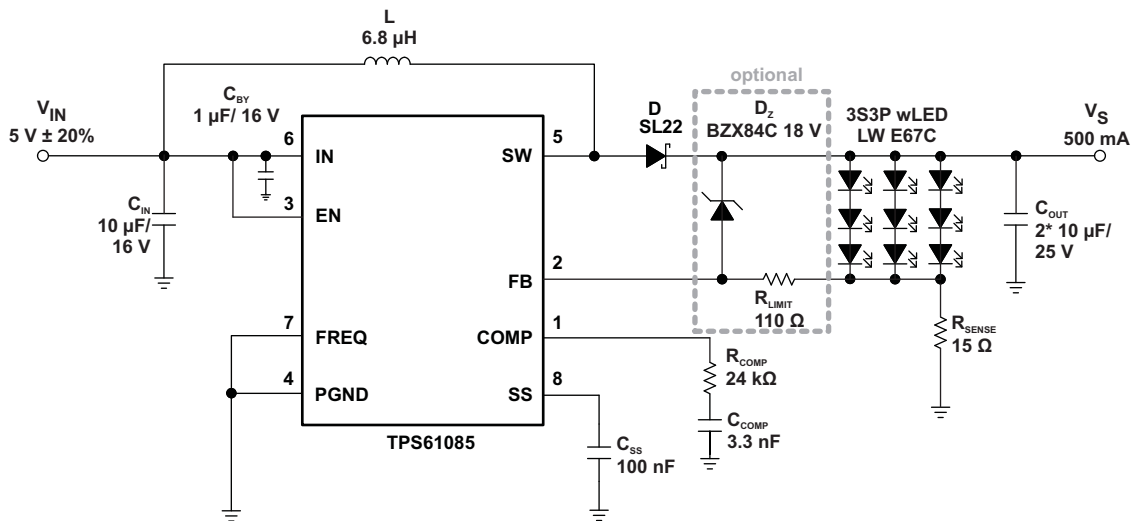

Figure 20. Simple Application (3.3V input -  $f_{sw} = 650 \text{ kHz}$ ) for wLED Supply (3S3P) (with Optional Clamping Zener Diode)

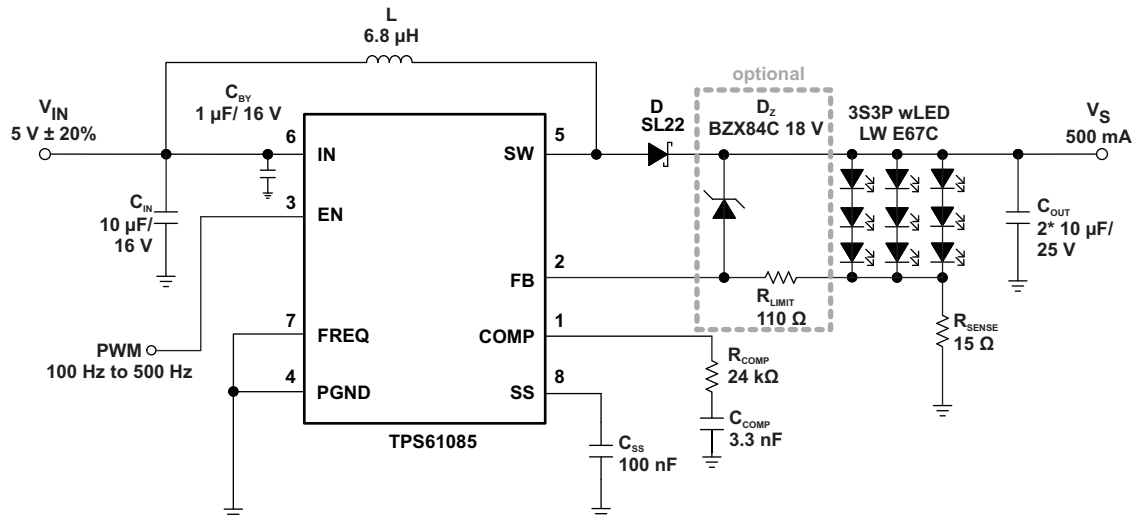

Figure 21. Simple Application (3.3V input -  $f_{sw} = 650$  kHz) for wLED Supply (3S3P) with Adjustable Brightness Control using a PWM Signal on the Enable Pin (with Optional Clamping Zener Diode)

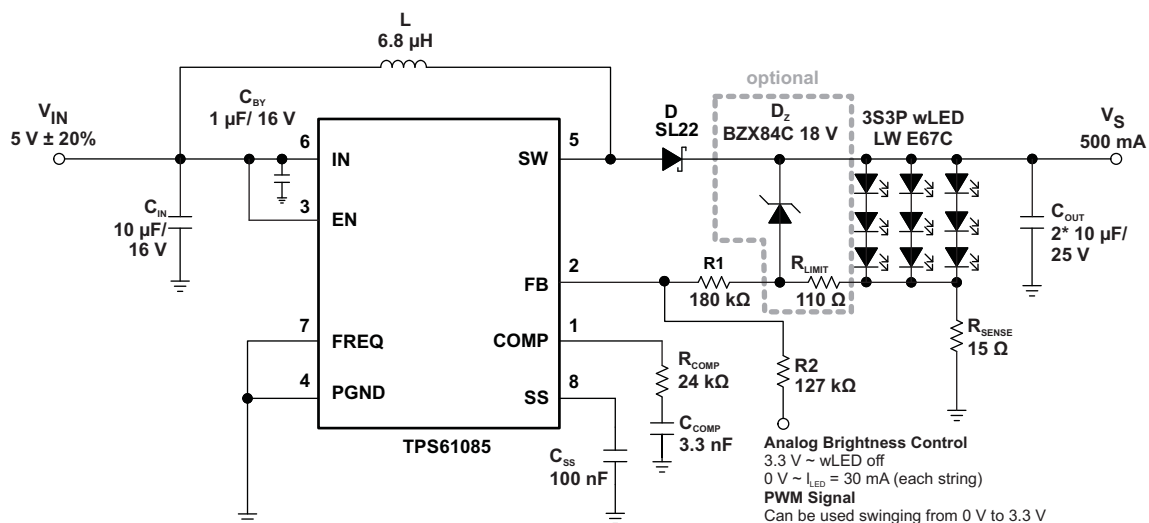

Figure 22. Simple Application (3.3V input -  $f_{sw} = 650$  kHz) for wLED Supply (3S3P) with Adjustable Brightness Control using an Analog Signal on the Feedback Pin (with Optional Clamping Zener Diode)

## REVISION HISTORY

Changes from Original (June 2008) to Revision A	Page
• Changed the circuit illustration value of $C_{COMP}$ From: 1.6 nF To: 1.1 nF .....	1
• Deleted Lead Temperature from the Abs Max table .....	2
• Added a conditions statement and two new graphs (Max Load Current vs Input Voltage) to the Typical Characteristics graphs .....	5
• Added three paragraphs of text to the Detailed Description - following the Block Diagram (Figure 13) .....	8
• Changed the Design Procedures step 3 details following Equation 4 .....	9
• Changed text in the Inductor Selection section "inductor current ripple is below 20%" to " inductor current ripple is below 35%" .....	10
• Changed Equation 8 .....	11
• Added Used $I_{OUT}$ to Table 3 .....	12
• Added Equation 10 .....	12
• Changed Figure 14 to Figure 18 .....	13
• Changed the White LED Applications optional Zener connection for Figure 20 to Figure 22 .....	16

**PACKAGING INFORMATION**

Orderable Device	Status (1)	Package Type	Package Drawing	Pins	Package Qty	Eco Plan (2)	Lead/Ball Finish (6)	MSL Peak Temp (3)	Op Temp (°C)	Device Marking (4/5)	Samples
TPS61085DGKR	ACTIVE	VSSOP	DGK	8	2500	Green (RoHS & no Sb/Br)	CU NIPDAU	Level-1-260C-UNLIM	-40 to 85	PMKI	<a href="#">Samples</a>
TPS61085DGKRG4	ACTIVE	VSSOP	DGK	8	2500	Green (RoHS & no Sb/Br)	CU NIPDAU	Level-1-260C-UNLIM	-40 to 85	PMKI	<a href="#">Samples</a>
TPS61085DGKT	ACTIVE	VSSOP	DGK	8	250	Green (RoHS & no Sb/Br)	CU NIPDAU	Level-1-260C-UNLIM	-40 to 85	PMKI	<a href="#">Samples</a>
TPS61085DGKTG4	ACTIVE	VSSOP	DGK	8	250	Green (RoHS & no Sb/Br)	CU NIPDAU	Level-1-260C-UNLIM	-40 to 85	PMKI	<a href="#">Samples</a>
TPS61085PW	ACTIVE	TSSOP	PW	8	150	Green (RoHS & no Sb/Br)	CU NIPDAU	Level-1-260C-UNLIM	-40 to 85	61085	<a href="#">Samples</a>
TPS61085PWG4	ACTIVE	TSSOP	PW	8	150	Green (RoHS & no Sb/Br)	CU NIPDAU	Level-1-260C-UNLIM	-40 to 85	61085	<a href="#">Samples</a>
TPS61085PWR	ACTIVE	TSSOP	PW	8	2000	Green (RoHS & no Sb/Br)	CU NIPDAU	Level-1-260C-UNLIM	-40 to 85	61085	<a href="#">Samples</a>
TPS61085PWRG4	ACTIVE	TSSOP	PW	8	2000	Green (RoHS & no Sb/Br)	CU NIPDAU	Level-1-260C-UNLIM	-40 to 85	61085	<a href="#">Samples</a>

(1) The marketing status values are defined as follows:

**ACTIVE:** Product device recommended for new designs.

**LIFEBUY:** TI has announced that the device will be discontinued, and a lifetime-buy period is in effect.

**NRND:** Not recommended for new designs. Device is in production to support existing customers, but TI does not recommend using this part in a new design.

**PREVIEW:** Device has been announced but is not in production. Samples may or may not be available.

**OBSOLETE:** TI has discontinued the production of the device.

(2) Eco Plan - The planned eco-friendly classification: Pb-Free (RoHS), Pb-Free (RoHS Exempt), or Green (RoHS & no Sb/Br) - please check <http://www.ti.com/productcontent> for the latest availability information and additional product content details.

**TBD:** The Pb-Free/Green conversion plan has not been defined.

**Pb-Free (RoHS):** TI's terms "Lead-Free" or "Pb-Free" mean semiconductor products that are compatible with the current RoHS requirements for all 6 substances, including the requirement that lead not exceed 0.1% by weight in homogeneous materials. Where designed to be soldered at high temperatures, TI Pb-Free products are suitable for use in specified lead-free processes.

**Pb-Free (RoHS Exempt):** This component has a RoHS exemption for either 1) lead-based flip-chip solder bumps used between the die and package, or 2) lead-based die adhesive used between the die and leadframe. The component is otherwise considered Pb-Free (RoHS compatible) as defined above.

**Green (RoHS & no Sb/Br):** TI defines "Green" to mean Pb-Free (RoHS compatible), and free of Bromine (Br) and Antimony (Sb) based flame retardants (Br or Sb do not exceed 0.1% by weight in homogeneous material)

(3) MSL, Peak Temp. - The Moisture Sensitivity Level rating according to the JEDEC industry standard classifications, and peak solder temperature.

(4) There may be additional marking, which relates to the logo, the lot trace code information, or the environmental category on the device.

(5) Multiple Device Markings will be inside parentheses. Only one Device Marking contained in parentheses and separated by a "~" will appear on a device. If a line is indented then it is a continuation of the previous line and the two combined represent the entire Device Marking for that device.

(6) Lead/Ball Finish - Orderable Devices may have multiple material finish options. Finish options are separated by a vertical ruled line. Lead/Ball Finish values may wrap to two lines if the finish value exceeds the maximum column width.

**Important Information and Disclaimer:**The information provided on this page represents TI's knowledge and belief as of the date that it is provided. TI bases its knowledge and belief on information provided by third parties, and makes no representation or warranty as to the accuracy of such information. Efforts are underway to better integrate information from third parties. TI has taken and continues to take reasonable steps to provide representative and accurate information but may not have conducted destructive testing or chemical analysis on incoming materials and chemicals. TI and TI suppliers consider certain information to be proprietary, and thus CAS numbers and other limited information may not be available for release.

In no event shall TI's liability arising out of such information exceed the total purchase price of the TI part(s) at issue in this document sold by TI to Customer on an annual basis.

**OTHER QUALIFIED VERSIONS OF TPS61085 :**

- Automotive: [TPS61085-Q1](#)

NOTE: Qualified Version Definitions:

- Automotive - Q100 devices qualified for high-reliability automotive applications targeting zero defects

## TAPE AND REEL INFORMATION



### QUADRANT ASSIGNMENTS FOR PIN 1 ORIENTATION IN TAPE



\*All dimensions are nominal

Device	Package Type	Package Drawing	Pins	SPQ	Reel Diameter (mm)	Reel Width W1 (mm)	A0 (mm)	B0 (mm)	K0 (mm)	P1 (mm)	W (mm)	Pin1 Quadrant
TPS61085DGKR	VSSOP	DGK	8	2500	330.0	12.4	5.3	3.4	1.4	8.0	12.0	Q1
TPS61085DGKT	VSSOP	DGK	8	250	180.0	12.4	5.3	3.4	1.4	8.0	12.0	Q1
TPS61085PWR	TSSOP	PW	8	2000	330.0	12.4	7.0	3.6	1.6	8.0	12.0	Q1

**TAPE AND REEL BOX DIMENSIONS**

\*All dimensions are nominal

Device	Package Type	Package Drawing	Pins	SPQ	Length (mm)	Width (mm)	Height (mm)
TPS61085DGKR	VSSOP	DGK	8	2500	367.0	367.0	35.0
TPS61085DGKT	VSSOP	DGK	8	250	210.0	185.0	35.0
TPS61085PWR	TSSOP	PW	8	2000	367.0	367.0	35.0





- NOTES:
- A. All linear dimensions are in millimeters.
  - B. This drawing is subject to change without notice.
  - C. Publication IPC-7351 is recommended for alternate designs.
  - D. Laser cutting apertures with trapezoidal walls and also rounding corners will offer better paste release. Customers should contact their board assembly site for stencil design recommendations. Refer to IPC-7525 for other stencil recommendations.
  - E. Customers should contact their board fabrication site for solder mask tolerances between and around signal pads.

PW (R-PDSO-G8)

PLASTIC SMALL OUTLINE

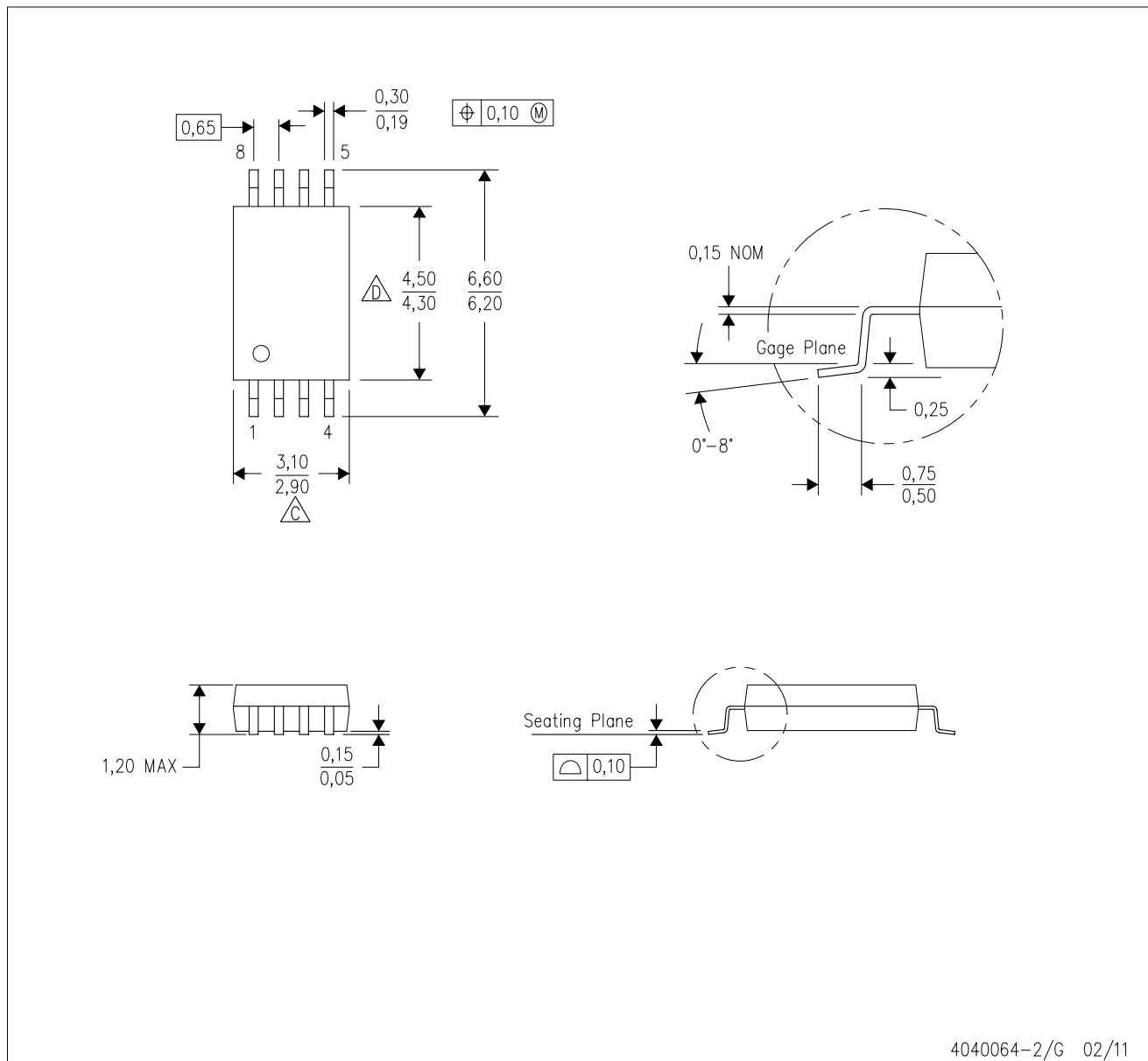

- NOTES:
- A. All linear dimensions are in millimeters. Dimensioning and tolerancing per ASME Y14.5M-1994.
  - B. This drawing is subject to change without notice.
  - C. Body length does not include mold flash, protrusions, or gate burrs. Mold flash, protrusions, or gate burrs shall not exceed 0,15 each side.
  - D. Body width does not include interlead flash. Interlead flash shall not exceed 0,25 each side.
  - E. Falls within JEDEC MO-153

## IMPORTANT NOTICE

Texas Instruments Incorporated and its subsidiaries (TI) reserve the right to make corrections, enhancements, improvements and other changes to its semiconductor products and services per JESD46, latest issue, and to discontinue any product or service per JESD48, latest issue. Buyers should obtain the latest relevant information before placing orders and should verify that such information is current and complete. All semiconductor products (also referred to herein as "components") are sold subject to TI's terms and conditions of sale supplied at the time of order acknowledgment.

TI warrants performance of its components to the specifications applicable at the time of sale, in accordance with the warranty in TI's terms and conditions of sale of semiconductor products. Testing and other quality control techniques are used to the extent TI deems necessary to support this warranty. Except where mandated by applicable law, testing of all parameters of each component is not necessarily performed.

TI assumes no liability for applications assistance or the design of Buyers' products. Buyers are responsible for their products and applications using TI components. To minimize the risks associated with Buyers' products and applications, Buyers should provide adequate design and operating safeguards.

TI does not warrant or represent that any license, either express or implied, is granted under any patent right, copyright, mask work right, or other intellectual property right relating to any combination, machine, or process in which TI components or services are used. Information published by TI regarding third-party products or services does not constitute a license to use such products or services or a warranty or endorsement thereof. Use of such information may require a license from a third party under the patents or other intellectual property of the third party, or a license from TI under the patents or other intellectual property of TI.

Reproduction of significant portions of TI information in TI data books or data sheets is permissible only if reproduction is without alteration and is accompanied by all associated warranties, conditions, limitations, and notices. TI is not responsible or liable for such altered documentation. Information of third parties may be subject to additional restrictions.

Resale of TI components or services with statements different from or beyond the parameters stated by TI for that component or service voids all express and any implied warranties for the associated TI component or service and is an unfair and deceptive business practice. TI is not responsible or liable for any such statements.

Buyer acknowledges and agrees that it is solely responsible for compliance with all legal, regulatory and safety-related requirements concerning its products, and any use of TI components in its applications, notwithstanding any applications-related information or support that may be provided by TI. Buyer represents and agrees that it has all the necessary expertise to create and implement safeguards which anticipate dangerous consequences of failures, monitor failures and their consequences, lessen the likelihood of failures that might cause harm and take appropriate remedial actions. Buyer will fully indemnify TI and its representatives against any damages arising out of the use of any TI components in safety-critical applications.

In some cases, TI components may be promoted specifically to facilitate safety-related applications. With such components, TI's goal is to help enable customers to design and create their own end-product solutions that meet applicable functional safety standards and requirements. Nonetheless, such components are subject to these terms.

No TI components are authorized for use in FDA Class III (or similar life-critical medical equipment) unless authorized officers of the parties have executed a special agreement specifically governing such use.

Only those TI components which TI has specifically designated as military grade or "enhanced plastic" are designed and intended for use in military/aerospace applications or environments. Buyer acknowledges and agrees that any military or aerospace use of TI components which have **not** been so designated is solely at the Buyer's risk, and that Buyer is solely responsible for compliance with all legal and regulatory requirements in connection with such use.

TI has specifically designated certain components as meeting ISO/TS16949 requirements, mainly for automotive use. In any case of use of non-designated products, TI will not be responsible for any failure to meet ISO/TS16949.

### Products

Audio	<a href="http://www.ti.com/audio">www.ti.com/audio</a>
Amplifiers	<a href="http://amplifier.ti.com">amplifier.ti.com</a>
Data Converters	<a href="http://dataconverter.ti.com">dataconverter.ti.com</a>
DLP® Products	<a href="http://www.dlp.com">www.dlp.com</a>
DSP	<a href="http://dsp.ti.com">dsp.ti.com</a>
Clocks and Timers	<a href="http://www.ti.com/clocks">www.ti.com/clocks</a>
Interface	<a href="http://interface.ti.com">interface.ti.com</a>
Logic	<a href="http://logic.ti.com">logic.ti.com</a>
Power Mgmt	<a href="http://power.ti.com">power.ti.com</a>
Microcontrollers	<a href="http://microcontroller.ti.com">microcontroller.ti.com</a>
RFID	<a href="http://www.ti-rfid.com">www.ti-rfid.com</a>
OMAP Applications Processors	<a href="http://www.ti.com/omap">www.ti.com/omap</a>
Wireless Connectivity	<a href="http://www.ti.com/wirelessconnectivity">www.ti.com/wirelessconnectivity</a>

### Applications

Automotive and Transportation	<a href="http://www.ti.com/automotive">www.ti.com/automotive</a>
Communications and Telecom	<a href="http://www.ti.com/communications">www.ti.com/communications</a>
Computers and Peripherals	<a href="http://www.ti.com/computers">www.ti.com/computers</a>
Consumer Electronics	<a href="http://www.ti.com/consumer-apps">www.ti.com/consumer-apps</a>
Energy and Lighting	<a href="http://www.ti.com/energy">www.ti.com/energy</a>
Industrial	<a href="http://www.ti.com/industrial">www.ti.com/industrial</a>
Medical	<a href="http://www.ti.com/medical">www.ti.com/medical</a>
Security	<a href="http://www.ti.com/security">www.ti.com/security</a>
Space, Avionics and Defense	<a href="http://www.ti.com/space-avionics-defense">www.ti.com/space-avionics-defense</a>
Video and Imaging	<a href="http://www.ti.com/video">www.ti.com/video</a>

### TI E2E Community

[e2e.ti.com](http://e2e.ti.com)