

TPS60400, TPS60401, TPS60402, TPS60403 UNREGULATED 60-mA CHARGE PUMP VOLTAGE INVERTER

SLVS324A – JULY 2001 REVISED NOVEMBER 2004

features

- Inverts Input Supply Voltage
- Up to 60-mA Output Current
- Only Three Small 1- μ F Ceramic Capacitors Needed
- Input Voltage Range From 1.6 V to 5.5 V
- PowerSave-Mode for Improved Efficiency at Low Output Currents (TPS60400)
- Device Quiescent Current Typical 65 μ A
- Integrated Active Schottky-Diode for Start-Up Into Load
- Small 5-Pin SOT23 Package
- Evaluation Module Available
TPS60400EVM-178

applications

- LCD Bias
- GaAs Bias for RF Power Amps
- Sensor Supply in Portable Instruments
- Bipolar Amplifier Supply
- Medical Instruments
- Battery-Operated Equipment

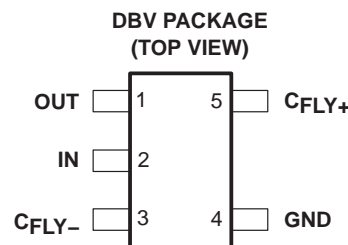

description

The TPS6040x is a family of devices that generate an unregulated negative output voltage from an input voltage ranging from 1.6 V to 5.5 V. The devices are typically supplied by a preregulated supply rail of 5 V or 3.3 V. Due to its wide input voltage range, two or three NiCd, NiMH, or alkaline battery cells, as well as one Li-Ion cell can also power them.

Only three external 1- μ F capacitors are required to build a complete dc/dc charge pump inverter. Assembled in a 5-pin SOT23 package, the complete converter can be built on a 50 mm² board area. Additional board area and component count reduction is achieved by replacing the Schottky diode that is typically needed for start-up into load by integrated circuitry.

The TPS6040x can deliver a maximum output current of 60 mA with a typical conversion efficiency of greater than 90% over a wide output current range. Three device options with 20-kHz, 50-kHz, and 250-kHz fixed frequency operation are available. One device comes with a variable switching frequency to reduce operating current in applications with a wide load range and enables the design with low-value capacitors.

typical application circuit

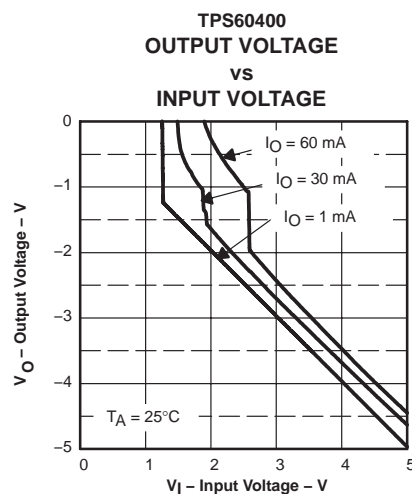
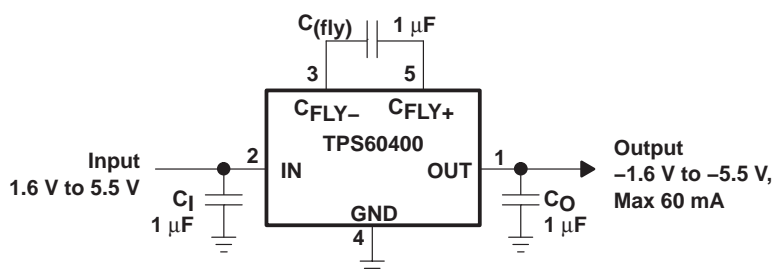

Please be aware that an important notice concerning availability, standard warranty, and use in critical applications of Texas Instruments semiconductor products and disclaimers thereto appears at the end of this data sheet.

PRODUCTION DATA information is current as of publication date. Products conform to specifications per the terms of Texas Instruments standard warranty. Production processing does not necessarily include testing of all parameters.

 **TEXAS
INSTRUMENTS**
WWW.TI.COM

Copyright © 2001–2004, Texas Instruments Incorporated

TPS60400, TPS60401, TPS60402, TPS60403 UNREGULATED 60-mA CHARGE PUMP VOLTAGE INVERTER

SLVS324A – JULY 2001 REVISED NOVEMBER 2004

AVAILABLE OPTIONS

PART NUMBER†	MARKING DBV PACKAGE	TYPICAL FLYING CAPACITOR [μF]	FEATURE
TPS60400DBV	PFKI	1	Variable switching frequency 50 kHz–250 kHz
TPS60401DBV	PFLI	10	Fixed frequency 20 kHz
TPS60402DBV	PFMI	3.3	Fixed frequency 50 kHz
TPS60403DBV	PFNI	1	Fixed frequency 250 kHz

† The DBV package is available taped and reeled. Add R suffix to device type (e.g. TPS60400DBVR) to order quantities of 3000 devices per reel. Add T suffix to device type (e.g. TPS60400DBVT) to order quantities of 250 devices per reel.

TPS60400 functional block diagram

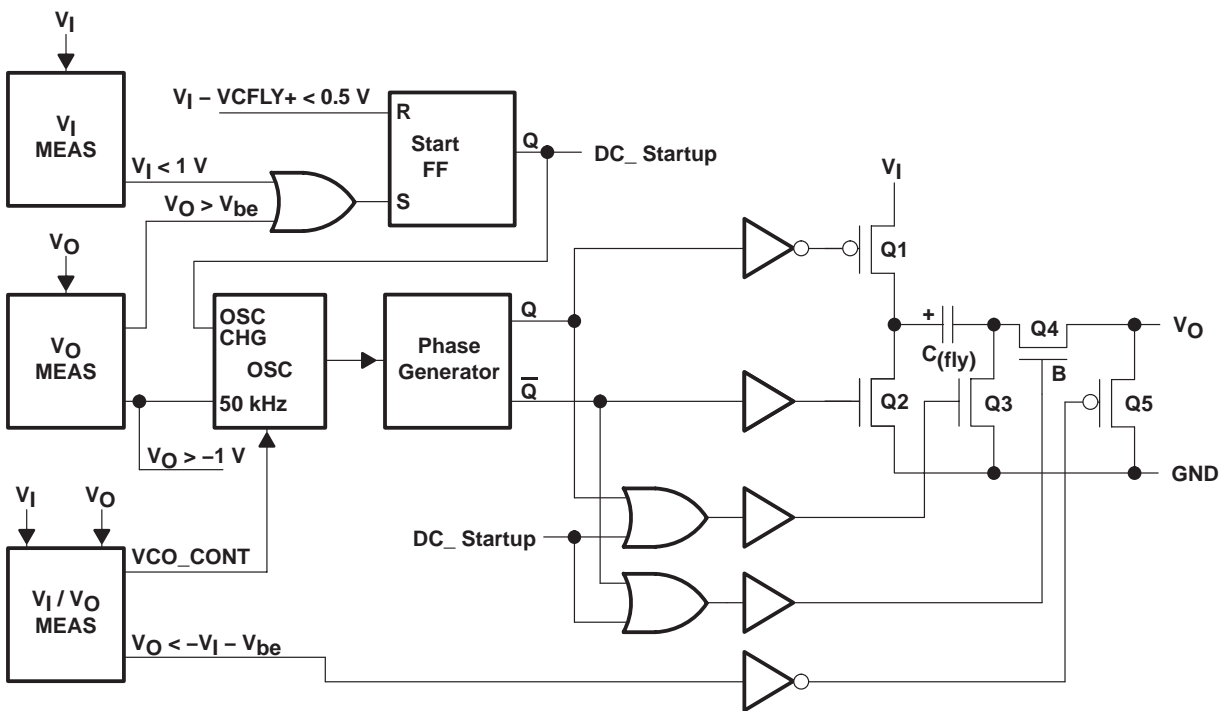

Terminal Functions

TERMINAL NAME	NO.	I/O	DESCRIPTION
CFLY+	5		Positive terminal of the flying capacitor $C_{(fly)}$
CFLY-	3		Negative terminal of the flying capacitor $C_{(fly)}$
GND	4		Ground
IN	2	I	Supply input. Connect to an input supply in the 1.6-V to 5.5-V range. Bypass IN to GND with a capacitor that has the same value as the flying capacitor.
OUT	1	O	Power output with $V_O = -V_I$ Bypass OUT to GND with the output filter capacitor C_O .

detailed description

operating principle

The TPS60400, TPS60401 charge pumps invert the voltage applied to their input. For the highest performance, use low equivalent series resistance (ESR) capacitors (e.g., ceramic). During the first half-cycle, switches S2 and S4 open, switches S1 and S3 close, and capacitor ($C_{(fly)}$) charges to the voltage at V_I . During the second half-cycle, S1 and S3 open, S2 and S4 close. This connects the positive terminal of $C_{(fly)}$ to GND and the negative to V_O . By connecting $C_{(fly)}$ in parallel, C_O is charged negative. The actual voltage at the output is more positive than $-V_I$, since switches S1–S4 have resistance and the load drains charge from C_O .

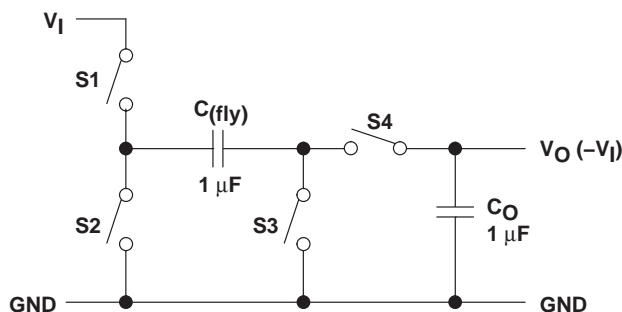

Figure 1. Operating Principle

charge-pump output resistance

The TPS6040x devices are not voltage regulators. The charge pumps output source resistance is approximately 15Ω at room temperature (with $V_I = 5 \text{ V}$), and V_O approaches -5 V when lightly loaded. V_O will droop toward GND as load current increases.

$$V_O = -(V_I - R_O \times I_O)$$

$$R_O \approx \frac{1}{f_{osc} \times C_{(fly)}} + 4(2R_{SWITCH} + ESR_{CFLY}) + ESR_{C_O} \tag{1}$$

R_O = output resistance of the converter

efficiency considerations

The power efficiency of a switched-capacitor voltage converter is affected by three factors: the internal losses in the converter IC, the resistive losses of the capacitors, and the conversion losses during charge transfer between the capacitors. The internal losses are associated with the IC's internal functions, such as driving the switches, oscillator, etc. These losses are affected by operating conditions such as input voltage, temperature, and frequency. The next two losses are associated with the voltage converter circuit's output resistance. Switch losses occur because of the on-resistance of the MOSFET switches in the IC. Charge-pump capacitor losses occur because of their ESR. The relationship between these losses and the output resistance is as follows:

$$P_{CAPACITOR \text{ LOSSES}} + P_{CONVERSION \text{ LOSSES}} = I_O^2 \times R_O$$

R_{SWITCH} = resistance of a single MOSFET-switch inside the converter
 f_{OSC} = oscillator frequency

The first term is the effective resistance from an ideal switched-capacitor circuit. Conversion losses occur during the charge transfer between $C_{(fly)}$ and C_O when there is a voltage difference between them. The power loss is:

$$P_{CONV.LOSS} = \left[\frac{1}{2} \times C_{(fly)} (V_I^2 - V_O^2) + \frac{1}{2} C_O (V_{RIPPLE}^2 - 2V_O V_{RIPPLE}) \right] \times f_{osc} \tag{2}$$

TPS60400, TPS60401, TPS60402, TPS60403

UNREGULATED 60-mA CHARGE PUMP VOLTAGE INVERTER

SLVS324A – JULY 2001 REVISED NOVEMBER 2004

efficiency considerations (continued)

The efficiency of the TPS6040x devices is dominated by their quiescent supply current at low output current and by their output impedance at higher current.

$$\eta \cong \frac{I_O}{I_O + I_Q} \left(1 - \frac{I_O \times R_O}{V_I} \right)$$

Where, I_Q = quiescent current.

capacitor selection

To maintain the lowest output resistance, use capacitors with low ESR (see Table 1). The charge-pump output resistance is a function of $C_{(fly)}$'s and C_O 's ESR. Therefore, minimizing the charge-pump capacitor's ESR minimizes the total output resistance. The capacitor values are closely linked to the required output current and the output noise and ripple requirements. It is possible to only use 1- μ F capacitors of the same type.

input capacitor (C_I)

Bypass the incoming supply to reduce its ac impedance and the impact of the TPS6040x switching noise. The recommended bypassing depends on the circuit configuration and where the load is connected. When the inverter is loaded from OUT to GND, current from the supply switches between $2 \times I_O$ and zero. Therefore, use a large bypass capacitor (e.g., equal to the value of $C_{(fly)}$) if the supply has high ac impedance.

flying capacitor ($C_{(fly)}$)

Increasing the flying capacitor's size reduces the output resistance. Small values increases the output resistance. Above a certain point, increasing $C_{(fly)}$'s capacitance has a negligible effect, because the output resistance becomes dominated by the internal switch resistance and capacitor ESR.

output capacitor (C_O)

Increasing the output capacitor's size reduces the output ripple voltage. Decreasing its ESR reduces both output resistance and ripple. Smaller capacitance values can be used with light loads if higher output ripple can be tolerated. Use the following equation to calculate the peak-to-peak ripple.

$$V_{O(ripple)} = \frac{I_O}{f_{osc} \times C_O} + 2 \times I_O \times ESR_{CO}$$

Table 1. Recommended Capacitor Values

DEVICE	V_I [V]	I_O [mA]	C_I [μ F]	$C_{(fly)}$ [μ F]	C_O [μ F]
TPS60400	1.8...5.5	60	1	1	1
TPS60401	1.8...5.5	60	10	10	10
TPS60402	1.8...5.5	60	3.3	3.3	3.3
TPS60403	1.8...5.5	60	1	1	1

TPS60400, TPS60401, TPS60402, TPS60403 UNREGULATED 60-mA CHARGE PUMP VOLTAGE INVERTER

SLVS324A – JULY 2001 REVISED NOVEMBER 2004

detailed description (continued)

Table 2. Recommended Capacitors

MANUFACTURER	PART NUMBER	SIZE	CAPACITANCE	TYPE
Taiyo Yuden	EMK212BJ474MG	0805	0.47 μ F	Ceramic
	LMK212BJ105KG	0805	1 μ F	Ceramic
	LMK212BJ225MG	0805	2.2 μ F	Ceramic
	EMK316BJ225KL	1206	2.2 μ F	Ceramic
	LMK316BJ475KL	1206	4.7 μ F	Ceramic
	JMK316BJ106KL	1206	10 μ F	Ceramic
TDK	C2012X5R1C105M	0805	1 μ F	Ceramic
	C2012X5R1A225M	0805	2.2 μ F	Ceramic
	C2012X5R1A335M	0805	3.3 μ F	Ceramic

Table 3 contains a list of manufacturers of the recommended capacitors. Ceramic capacitors will provide the lowest output voltage ripple because they typically have the lowest ESR-rating.

Table 3. Recommended Capacitor Manufacturers

MANUFACTURER	CAPACITOR TYPE	INTERNET
Taiyo Yuden	X7R/X5R ceramic	www.t-yuden.com
TDK	X7R/X5R ceramic	www.component.tdk.com
Vishay	X7R/X5R ceramic	www.vishay.com
Kemet	X7R/X5R ceramic	www.kemet.com

absolute maximum ratings over operating free-air temperature (unless otherwise noted)†

Voltage range: IN to GND	-0.3 V to 5.5 V
OUT to GND	-5.5 V to 0.3 V
C _{FLY-} to GND	0.3 V to (V _O - 0.3 V)
C _{FLY+} to GND	-0.3 V to (V _I + 0.3 V)
Continuous power dissipation	See Dissipation Rating Table
Continuous output current	80 mA
Storage temperature range, T _{stg}	-55°C to 150°C
Maximum junction temperature, T _J	150°C

† Stresses beyond those listed under “absolute maximum ratings” may cause permanent damage to the device. These are stress ratings only, and functional operation of the device at these or any other conditions beyond those indicated under “recommended operating conditions” is not implied. Exposure to absolute-maximum-rated conditions for extended periods may affect device reliability.

DISSIPATION RATING TABLE

PACKAGE	T _A < 25°C POWER RATING	DERATING FACTOR ABOVE T _A = 25°C	T _A = 70°C POWER RATING	T _A = 85°C POWER RATING
DBV	437 mW	3.5 mW/°C	280 mW	227 mW

TPS60400, TPS60401, TPS60402, TPS60403

UNREGULATED 60-mA CHARGE PUMP VOLTAGE INVERTER

SLVS324A – JULY 2001 REVISED NOVEMBER 2004

recommended operating conditions

	MIN	NOM	MAX	UNIT
Input voltage range, V_I	1.8		5.25	V
Output current range at OUT, I_O			60	mA
Input capacitor, C_I	0	$C_{(fly)}$		μF
Flying capacitor, $C_{(fly)}$		1		μF
Output capacitor, C_O		1	100	μF
Operating junction temperature, T_J	-40		125	$^{\circ}\text{C}$

electrical characteristics at $C_I = C_{(fly)} = C_O$ (according to Table 1), $T_C = -40^{\circ}\text{C}$ to 85°C , $V_I = 5\text{ V}$ over recommended operating free-air temperature range (unless otherwise noted)

PARAMETER		TEST CONDITIONS		MIN	TYP	MAX	UNIT	
V_I	Supply voltage range	At $T_C = -40^{\circ}\text{C}$ to 85°C , $R_L = 5\text{ k}\Omega$		1.8		5.25	V	
		At $T_C \geq 0^{\circ}\text{C}$, $R_L = 5\text{ k}\Omega$		1.6				
I_O	Maximum output current at V_O			60			mA	
V_O	Output voltage				$-V_I$		V	
V_{P-P}	Output voltage ripple	TPS60400	$I_O = 5\text{ mA}$	$C_{(fly)} = 1\text{ }\mu\text{F}$, $C_O = 2.2\text{ }\mu\text{F}$		35	mV _{P-P}	
		TPS60401			$C_{(fly)} = C_O = 10\text{ }\mu\text{F}$	20		
		TPS60402			$C_{(fly)} = C_O = 3.3\text{ }\mu\text{F}$	20		
		TPS60403			$C_{(fly)} = C_O = 1\text{ }\mu\text{F}$	15		
I_Q	Quiescent current (no-load input current)	TPS60400	At $V_I = 5\text{ V}$			125	270	μA
		TPS60401			65	190		
		TPS60402			120	270		
		TPS60403			425	700		
		TPS60400	At $T \leq 60^{\circ}\text{C}$, $V_I = 5\text{ V}$			210	μA	
		TPS60401			135			
		TPS60402			210			
		TPS60403			640			
f_{OSC}	Internal switching frequency	TPS60400	VCO version	30	50–250	350	kHz	
		TPS60401		13	20	28		
		TPS60402		30	50	70		
		TPS60403		150	250	300		
	Impedance at 25°C , $V_I = 5\text{ V}$	TPS60400	$C_I = C_{(fly)} = C_O = 1\text{ }\mu\text{F}$		12	15	Ω	
		TPS60401	$C_I = C_{(fly)} = C_O = 10\text{ }\mu\text{F}$		12	15		
		TPS60402	$C_I = C_{(fly)} = C_O = 3.3\text{ }\mu\text{F}$		12	15		
		TPS60403	$C_I = C_{(fly)} = C_O = 1\text{ }\mu\text{F}$		12	15		

TPS60400, TPS60401, TPS60402, TPS60403 UNREGULATED 60-mA CHARGE PUMP VOLTAGE INVERTER

SLVS324A – JULY 2001 REVISED NOVEMBER 2004

TYPICAL CHARACTERISTICS

Table of Graphs

			FIGURE
η	Efficiency	vs Output current at 3.3 V, 5 V TPS60400, TPS60401, TPS60402, TPS60403	2, 3
I_I	Input current	vs Output current TPS60400, TPS60401, TPS60402, TPS60403	4, 5
I_S	Supply current	vs Input voltage TPS60400, TPS60401, TPS60402, TPS60403	6, 7
	Output resistance	vs Input voltage at -40°C , 0°C , 25°C , 85°C TPS60400, $C_1 = C_{(\text{fly})} = C_O = 1 \mu\text{F}$ TPS60401, $C_1 = C_{(\text{fly})} = C_O = 10 \mu\text{F}$ TPS60402, $C_1 = C_{(\text{fly})} = C_O = 3.3 \mu\text{F}$ TPS60403, $C_1 = C_{(\text{fly})} = C_O = 1 \mu\text{F}$	8, 9, 10, 11
V_O	Output voltage	vs Output current at 25°C , $V_{\text{IN}}=1.8 \text{ V}$, 2.5 V , 3.3 V , 5 V TPS60400, $C_1 = C_{(\text{fly})} = C_O = 1 \mu\text{F}$ TPS60401, $C_1 = C_{(\text{fly})} = C_O = 10 \mu\text{F}$ TPS60402, $C_1 = C_{(\text{fly})} = C_O = 3.3 \mu\text{F}$ TPS60403, $C_1 = C_{(\text{fly})} = C_O = 1 \mu\text{F}$	12, 13, 14, 15
f_{OSC}	Oscillator frequency	vs Temperature at $V_I = 1.8 \text{ V}$, 2.5 V , 3.3 V , 5 V TPS60400, TPS60401, TPS60402, TPS60403	16, 17, 18, 19
f_{OSC}	Oscillator frequency	vs Output current TPS60400 at 2 V , 3.3 V , 5.0 V	20
	Output ripple and noise	$V_I = 5 \text{ V}$, $I_O = 30 \text{ mA}$, $C_1 = C_{(\text{fly})} = C_O = 1 \mu\text{F}$ (TPS60400) $V_I = 5 \text{ V}$, $I_O = 30 \text{ mA}$, $C_1 = C_{(\text{fly})} = C_O = 10 \mu\text{F}$ (TPS60401) $V_I = 5 \text{ V}$, $I_O = 30 \text{ mA}$, $C_1 = C_{(\text{fly})} = C_O = 3.3 \mu\text{F}$ (TPS60402) $V_I = 5 \text{ V}$, $I_O = 30 \text{ mA}$, $C_1 = C_{(\text{fly})} = C_O = 1 \mu\text{F}$ (TPS60403)	21, 22

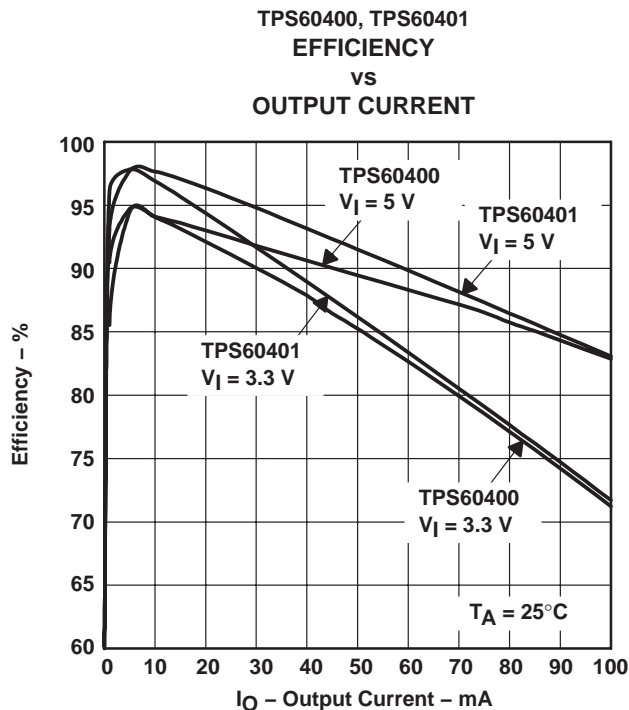

Figure 2

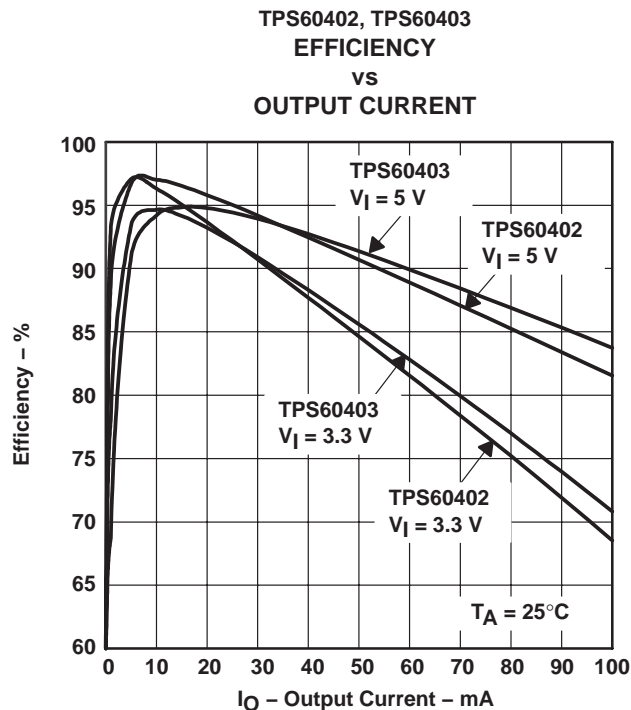

Figure 3

TPS60400, TPS60401, TPS60402, TPS60403 UNREGULATED 60-mA CHARGE PUMP VOLTAGE INVERTER

SLVS324A – JULY 2001 REVISED NOVEMBER 2004

TYPICAL CHARACTERISTICS

TPS60400, TPS60401
INPUT CURRENT
vs
OUTPUT CURRENT

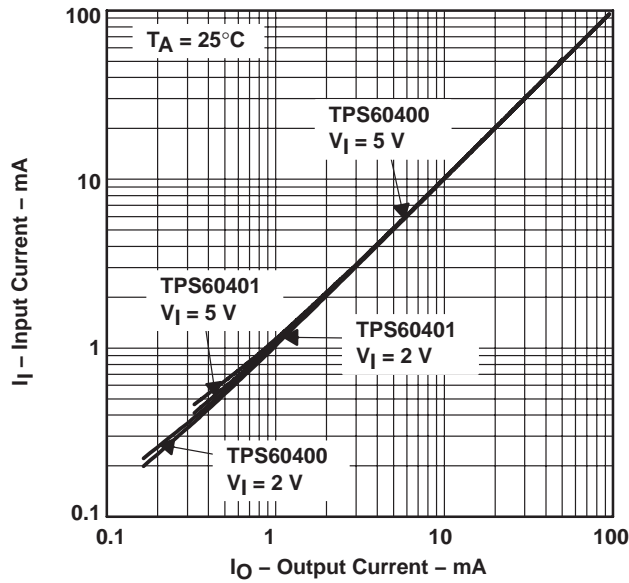

Figure 4

TPS60402, TPS60403
INPUT CURRENT
vs
OUTPUT CURRENT

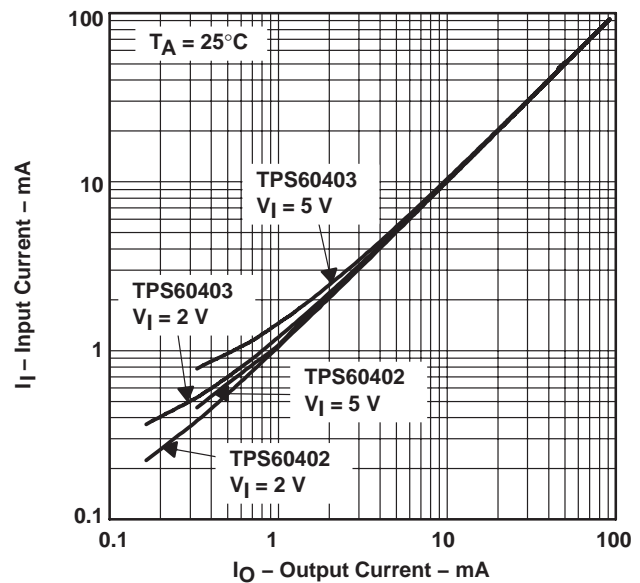

Figure 5

TPS60400, TPS60401
SUPPLY CURRENT
vs
INPUT VOLTAGE

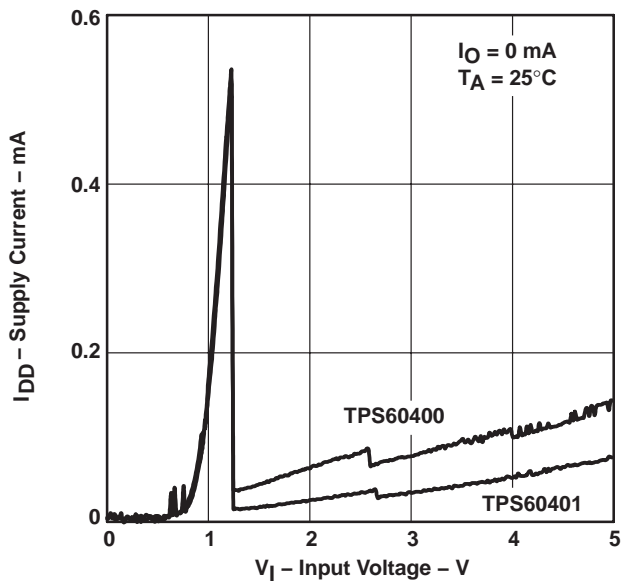

Figure 6

TPS60402, TPS60403
SUPPLY CURRENT
vs
INPUT VOLTAGE

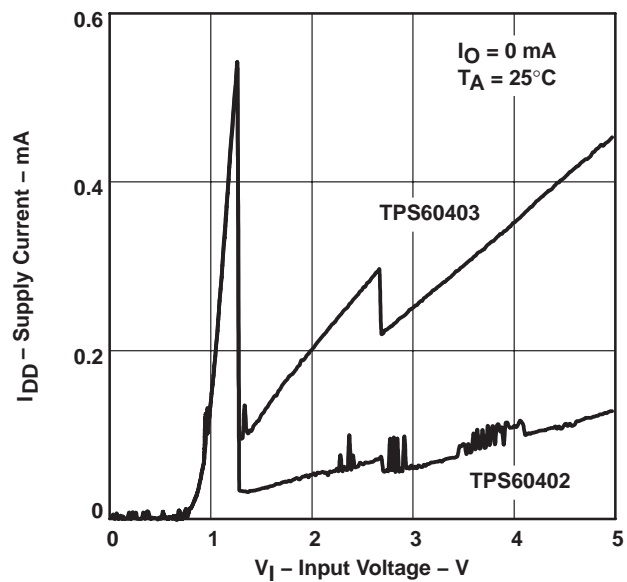
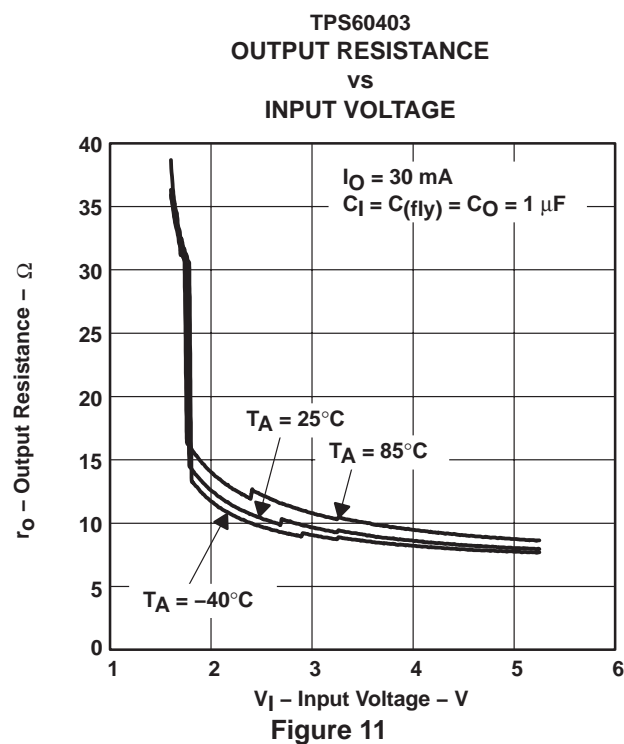
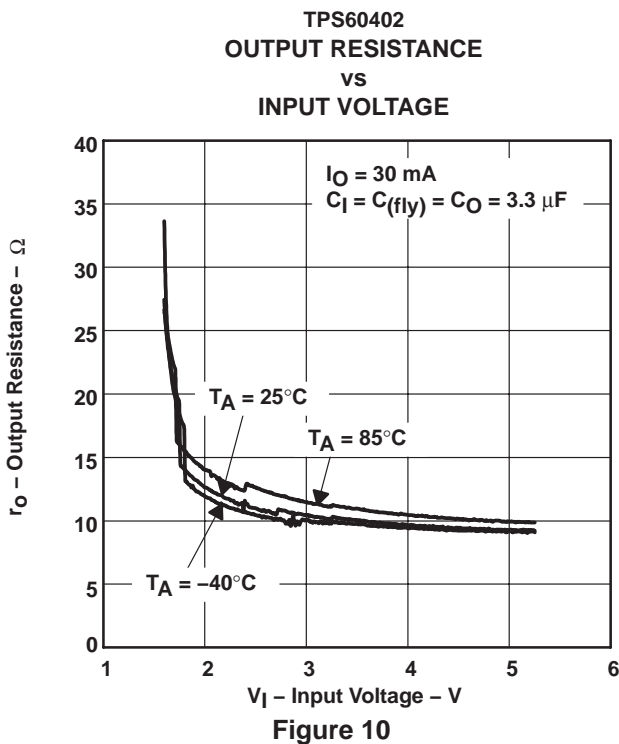
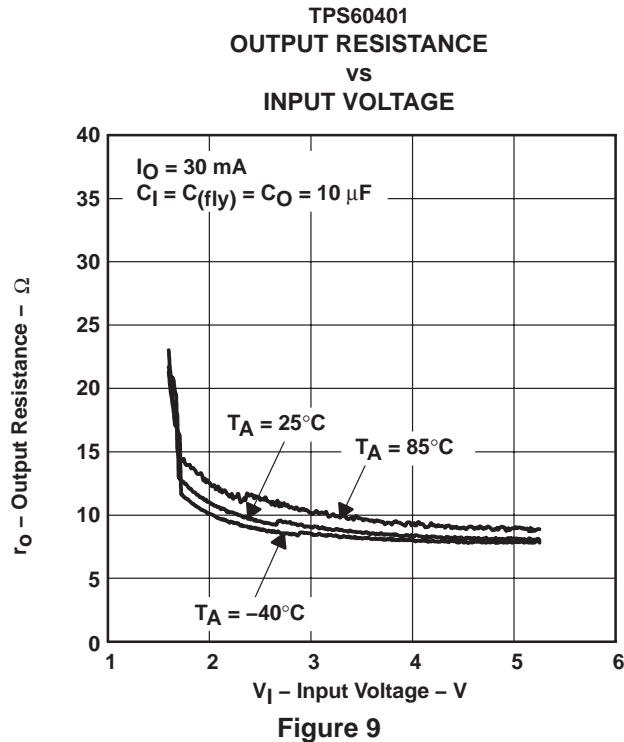
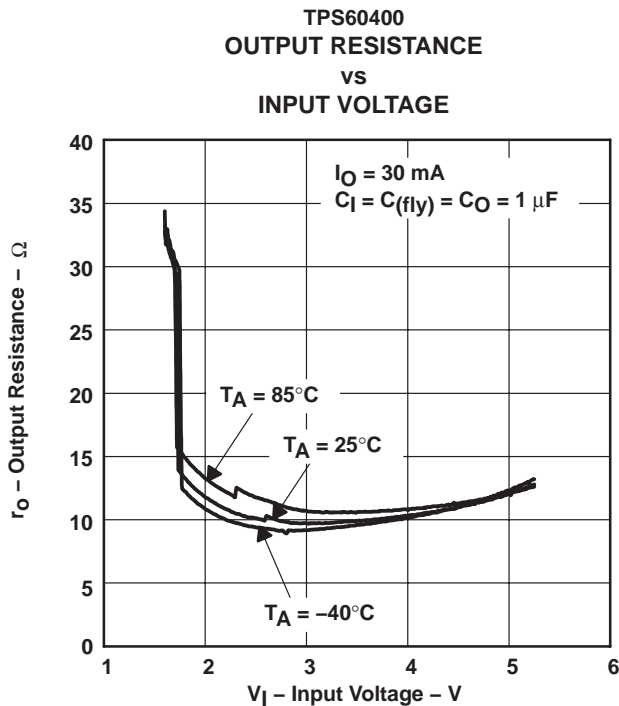

Figure 7

TPS60400, TPS60401, TPS60402, TPS60403 UNREGULATED 60-mA CHARGE PUMP VOLTAGE INVERTER

SLVS324A – JULY 2001 REVISED NOVEMBER 2004

TYPICAL CHARACTERISTICS



TPS60400, TPS60401, TPS60402, TPS60403

UNREGULATED 60-mA CHARGE PUMP VOLTAGE INVERTER

SLVS324A – JULY 2001 REVISED NOVEMBER 2004

TYPICAL CHARACTERISTICS

TPS60400
OUTPUT VOLTAGE
vs
OUTPUT CURRENT

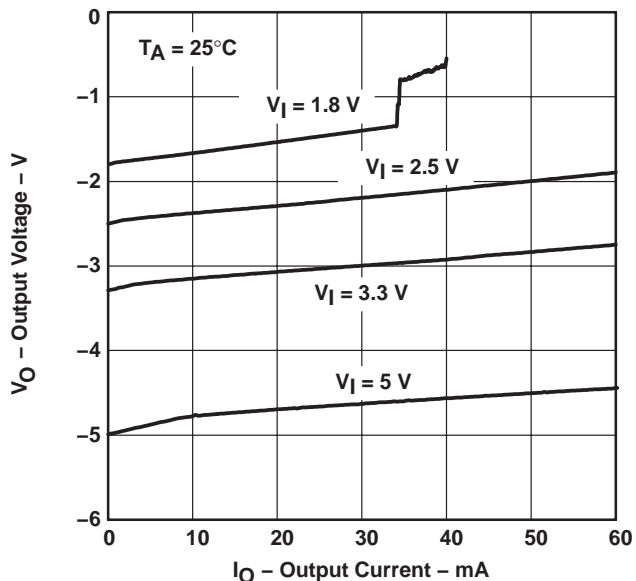

Figure 12

TPS60401
OUTPUT VOLTAGE
vs
OUTPUT CURRENT

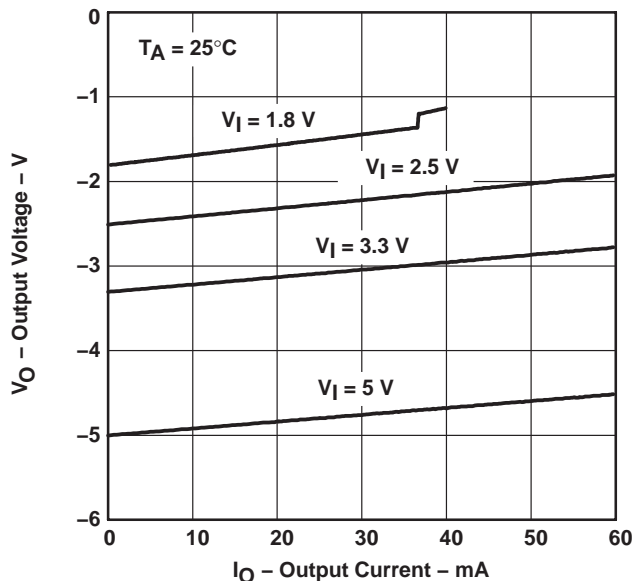

Figure 13

TPS60402
OUTPUT VOLTAGE
vs
OUTPUT CURRENT

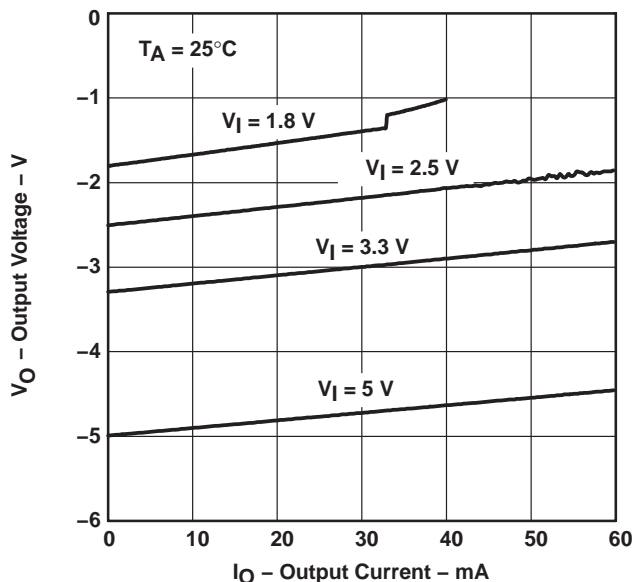

Figure 14

TPS60403
OUTPUT VOLTAGE
vs
OUTPUT CURRENT

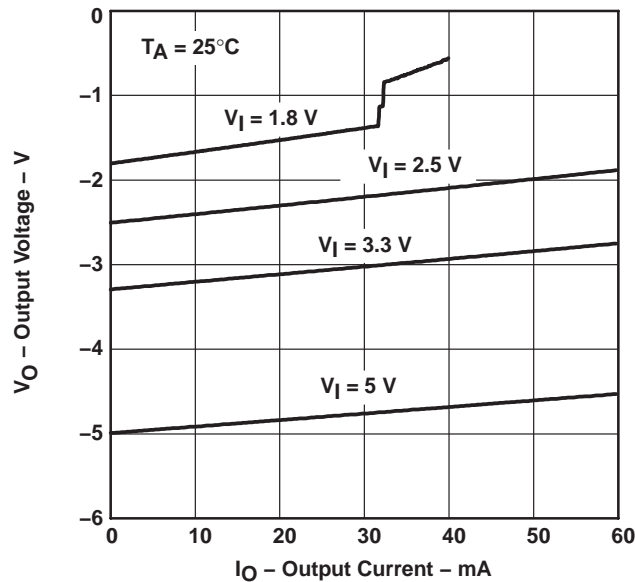
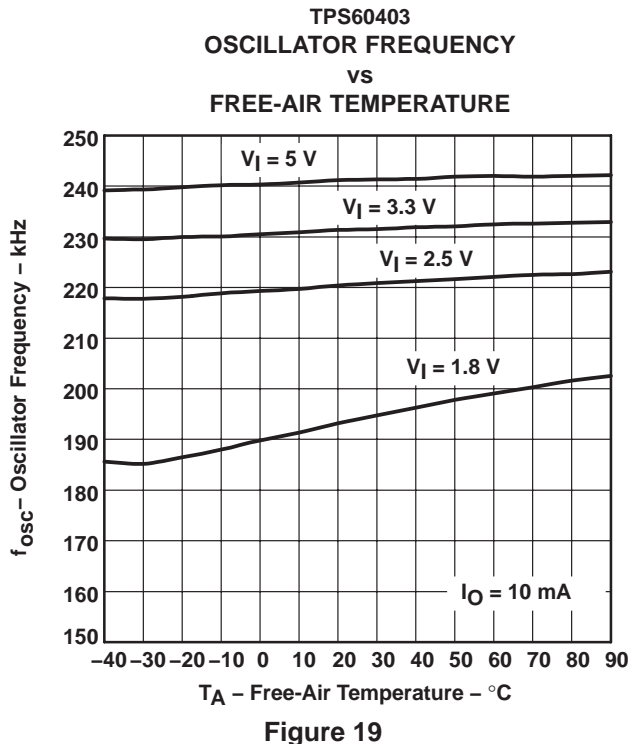
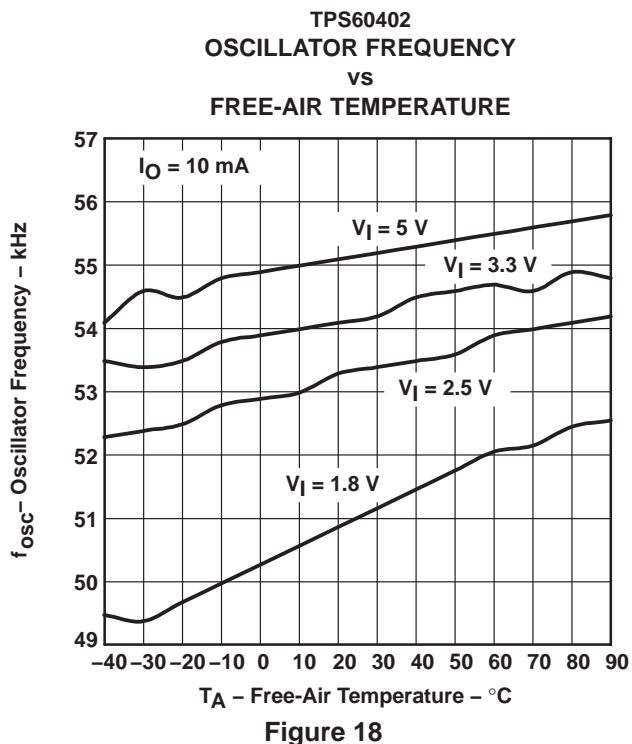
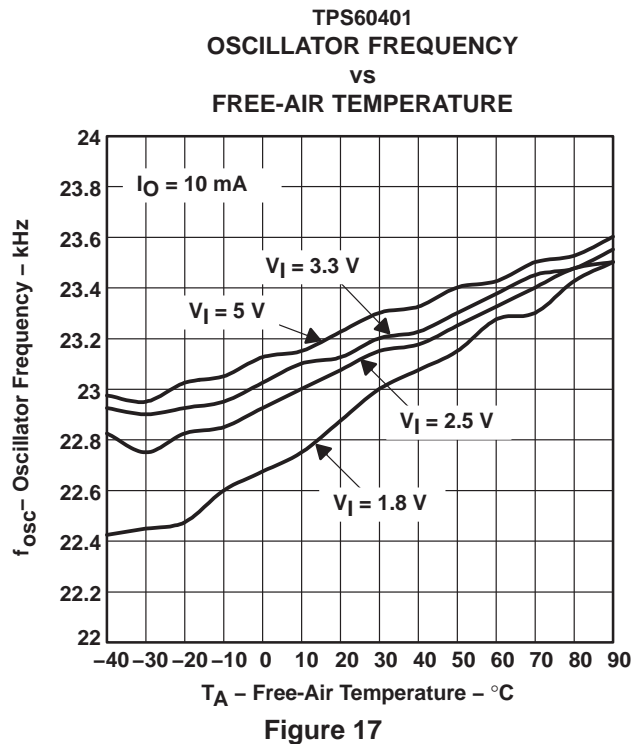
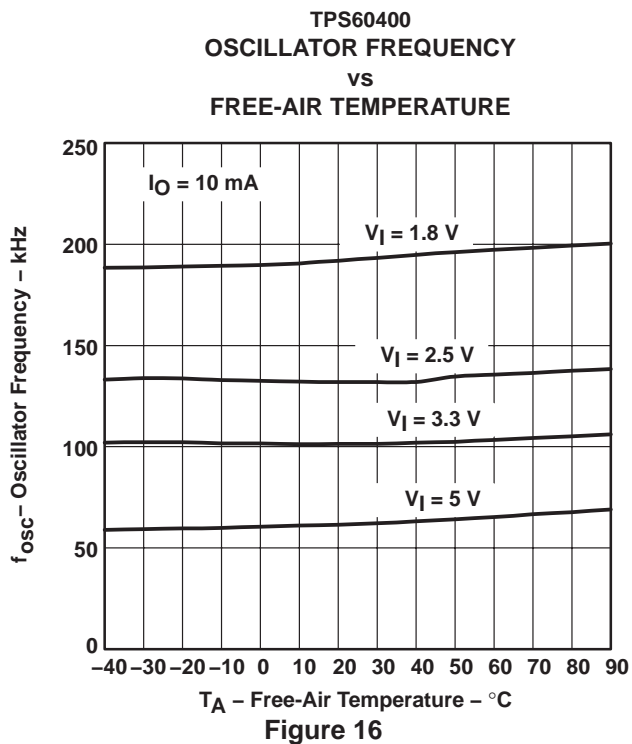

Figure 15

TPS60400, TPS60401, TPS60402, TPS60403 UNREGULATED 60-mA CHARGE PUMP VOLTAGE INVERTER

SLVS324A – JULY 2001 REVISED NOVEMBER 2004

TYPICAL CHARACTERISTICS



TPS60400, TPS60401, TPS60402, TPS60403 UNREGULATED 60-mA CHARGE PUMP VOLTAGE INVERTER

SLVS324A – JULY 2001 REVISED NOVEMBER 2004

TYPICAL CHARACTERISTICS

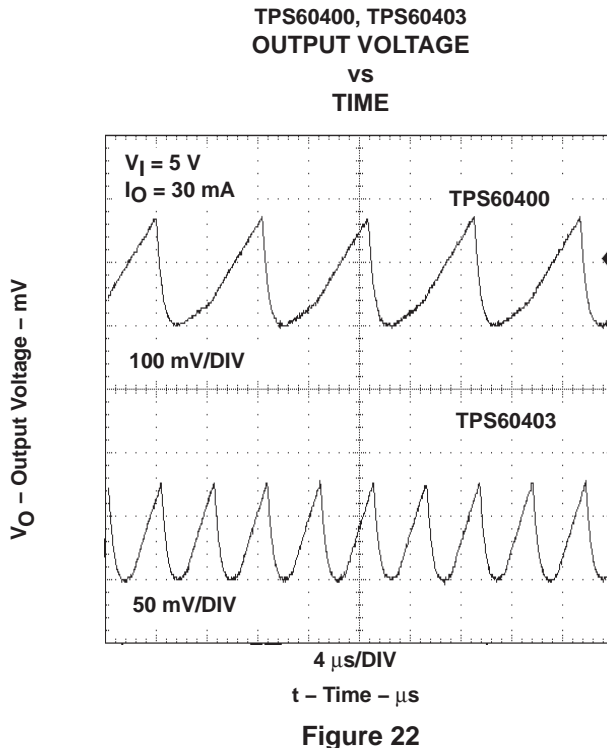
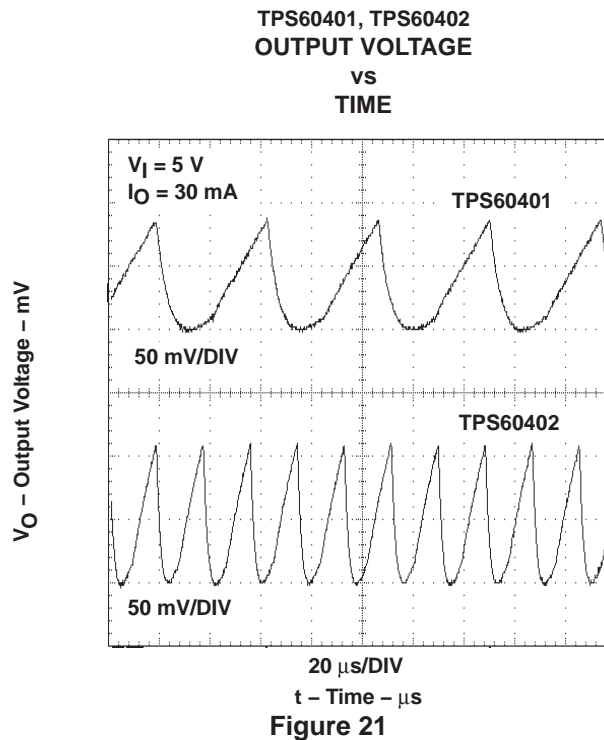
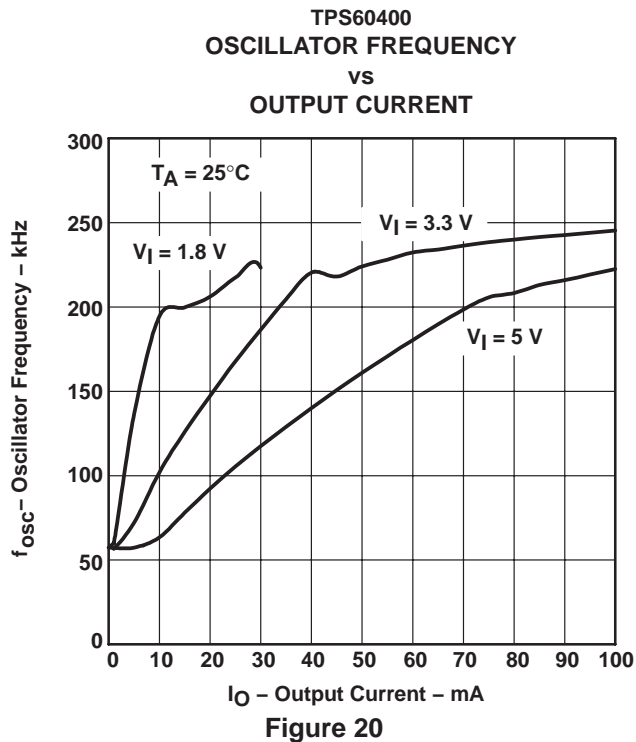

APPLICATION INFORMATION

voltage inverter

The most common application for these devices is a charge-pump voltage inverter (see Figure 23). This application requires only two external components; capacitors $C_{(fly)}$ and C_O , plus a bypass capacitor, if necessary. Refer to the capacitor selection section for suggested capacitor types.

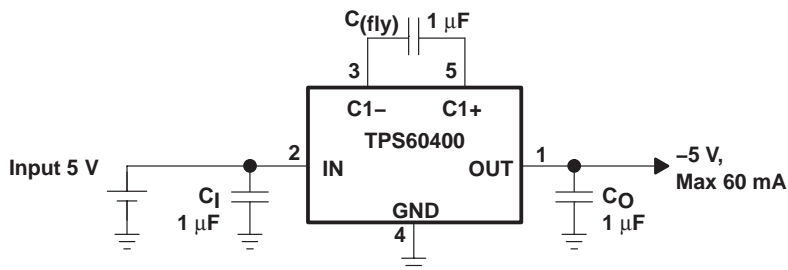

Figure 23. Typical Operating Circuit

For the maximum output current and best performance, three ceramic capacitors of 1 μ F (TPS60400, TPS60403) are recommended. For lower currents or higher allowed output voltage ripple, other capacitors can also be used. It is recommended that the output capacitors has a minimum value of 1 μ F. With flying capacitors lower than 1 μ F, the maximum output power will decrease.

TPS60400, TPS60401, TPS60402, TPS60403 UNREGULATED 60-mA CHARGE PUMP VOLTAGE INVERTER

SLVS324A – JULY 2001 REVISED NOVEMBER 2004

APPLICATION INFORMATION

RC-post filter

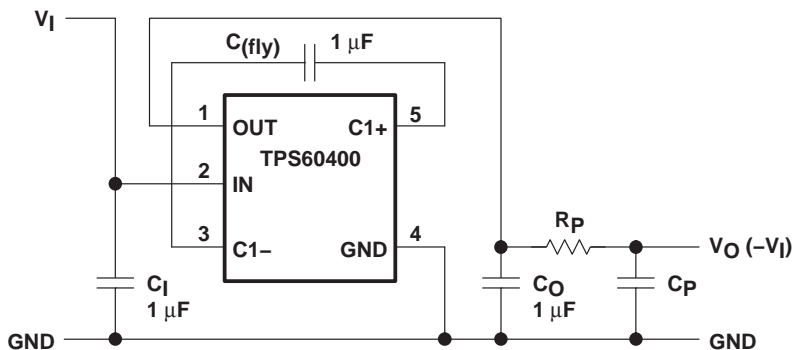

Figure 24. TPS60400 and TPS60401 With RC-Post Filter

An output filter can easily be formed with a resistor (R_P) and a capacitor (C_P). Cutoff frequency is given by:

$$f_c = \frac{1}{2\pi R_P C_P} \quad (1)$$

and ratio V_O/V_{OUT} is:

$$\left| \frac{V_O}{V_{OUT}} \right| = \frac{1}{\sqrt{1 + (2\pi f R_P C_P)^2}} \quad (2)$$

with $R_P = 50 \Omega$, $C_P = 0.1 \mu\text{F}$ and $f = 250 \text{ kHz}$: $\left| \frac{V_O}{V_{OUT}} \right| = 0.125$

The formula refers only to the relation between output and input of the ac ripple voltages of the filter.

LC-post filter

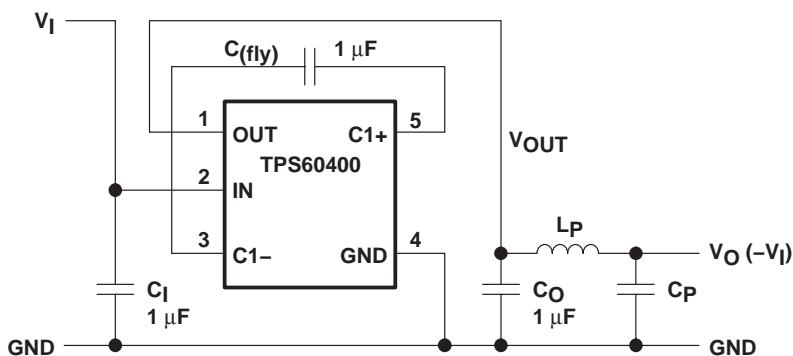

Figure 25. LC-Post Filter

Figure 25 shows a configuration with a LC-post filter to further reduce output ripple and noise.

TPS60400, TPS60401, TPS60402, TPS60403 UNREGULATED 60-mA CHARGE PUMP VOLTAGE INVERTER

SLVS324A – JULY 2001 REVISED NOVEMBER 2004

APPLICATION INFORMATION

Table 4. Measurement Results on the TPS60400 (Typical)

V_I [V]	$I_{O(2)}$ [mA]	C_I [μ F]	$C_{(fly)}$ [μ F]	C_O [μ F]	L_P [μ H]	C_P [μ F]	BW = 500 MHz $V_{P_{OUT}}$ V_{P-P} [mV]	BW = 20 MHz $V_{P_{OUT}}$ V_{P-P} [mV]	$V_{P_{OUT}}$ V_{ACeff} [mV]
		CERAMIC	CERAMIC	CERAMIC		CERAMIC			
5	60	1	1	1			320	240	65
5	60	1	1	2.2			120	240	32
5	60	1	1	1		0.1 (X7R)	260	200	58
5	60	1	1	1	0.1	0.1 (X7R)	220	200	60
5	60	1	1	2.2	0.1	0.1 (X7R)	120	100	30
5	60	1	1	10	0.1	0.1 (X7R)	50	28	8

rail splitter

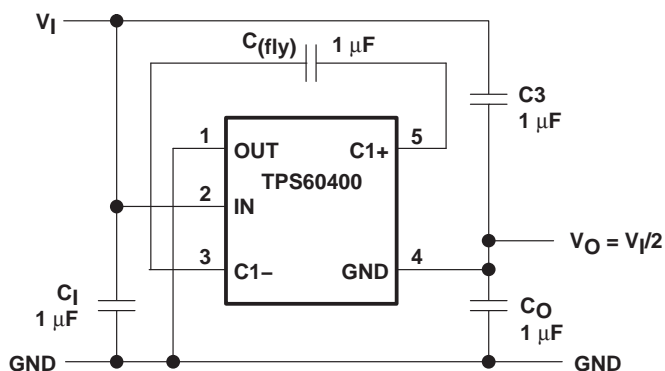

Figure 26. TPS60400 as a High-Efficiency Rail Splitter

A switched-capacitor voltage inverter can be configured as a high efficiency rail-splitter. This circuit provides a bipolar power supply that is useful in battery powered systems to supply dual-rail ICs, like operational amplifiers. Moreover, the SOT23-5 package and associated components require very little board space.

After power is applied, the flying capacitor ($C_{(fly)}$) connects alternately across the output capacitors C_3 and C_O . This equalizes the voltage on those capacitors and draws current from V_I to V_O as required to maintain the output at $1/2 V_I$.

The maximum input voltage between V_I and GND in the schematic (or between IN and OUT at the device itself) must not exceed 6.5 V.

TPS60400, TPS60401, TPS60402, TPS60403 UNREGULATED 60-mA CHARGE PUMP VOLTAGE INVERTER

SLVS324A – JULY 2001 REVISED NOVEMBER 2004

APPLICATION INFORMATION

combined doubler/inverter

In the circuit of Figure 27, capacitors C_1 , $C_{(fly)}$, and C_O form the inverter, while C_1 and C_2 form the doubler. C_1 and $C_{(fly)}$ are the flying capacitors; C_O and C_2 are the output capacitors. Because both the inverter and doubler use part of the charge-pump circuit, loading either output causes both outputs to decline toward GND. Make sure the sum of the currents drawn from the two outputs does not exceed 60 mA. The maximum output current at $V_{(pos)}$ must not exceed 30 mA. If the negative output is loaded, this current must be further reduced.

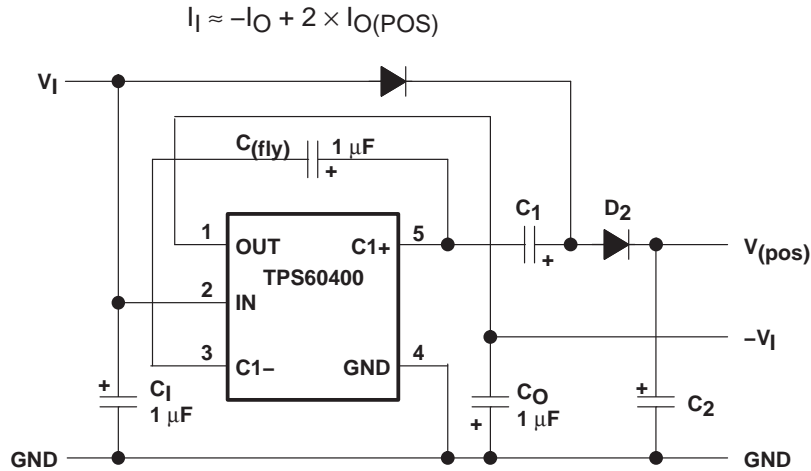

Figure 27. TPS60400 as Doubler/Inverter

cascading devices

Two devices can be cascaded to produce an even larger negative voltage (see Figure 28). The unloaded output voltage is normally $-2 \times V_I$, but this is reduced slightly by the output resistance of the first device multiplied by the quiescent current of the second. When cascading more than two devices, the output resistance rises dramatically.

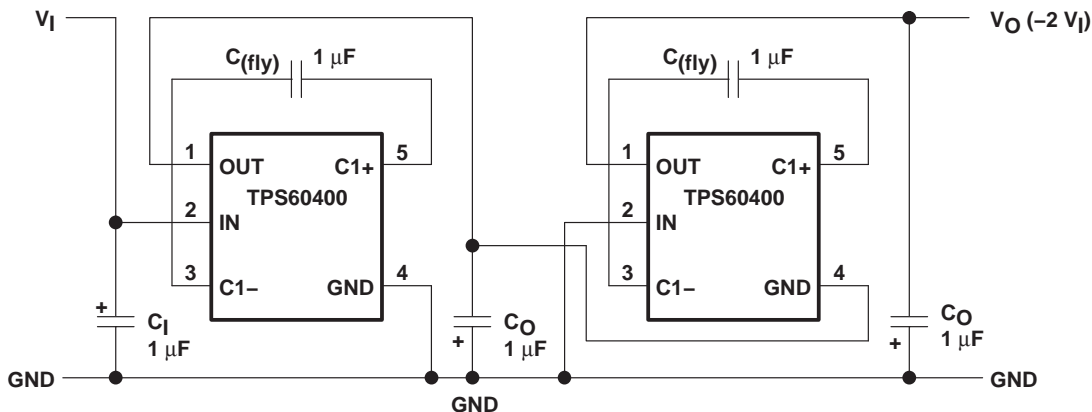

Figure 28. Doubling Inverter

APPLICATION INFORMATION

paralleling devices

Paralleling multiple TPS6040xs reduces the output resistance. Each device requires its own flying capacitor ($C_{(fly)}$), but the output capacitor (C_O) serves all devices (see Figure 29). Increase C_O 's value by a factor of n, where n is the number of parallel devices. Equation 1 on page 3 shows the equation for calculating output resistance.

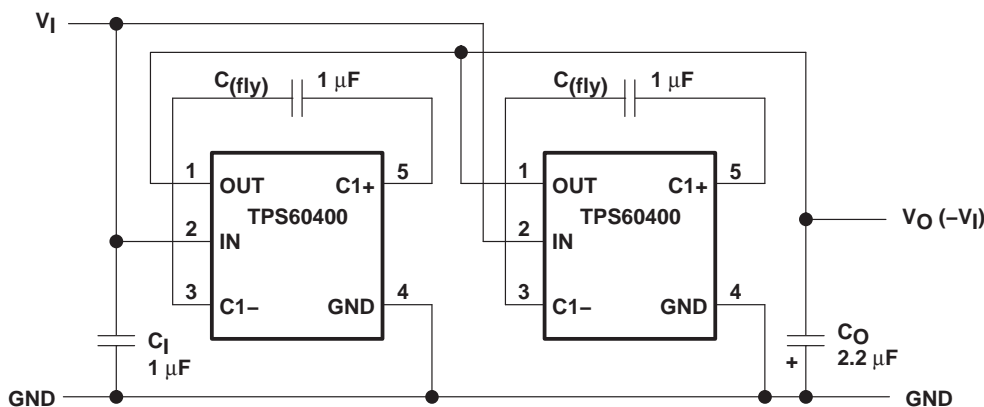

Figure 29. Paralleling Devices

active-Schottky diode

For a short period of time, when the input voltage is applied, but the inverter is not yet working, the output capacitor is charged positive by the load. To prevent the output being pulled above GND, a Schottky diode must be added in parallel to the output. The function of this diode is integrated into the TPS6040x devices, which gives a defined startup performance and saves board space.

A current sink and a diode in series can approximate the behavior of a typical, modern operational amplifier. Figure 30 shows the current into this typical load at a given voltage. The TPS6040x devices are optimized to start into these loads.

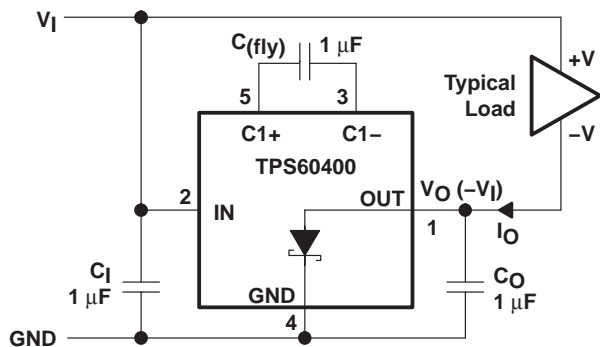

Figure 30. Typical Load

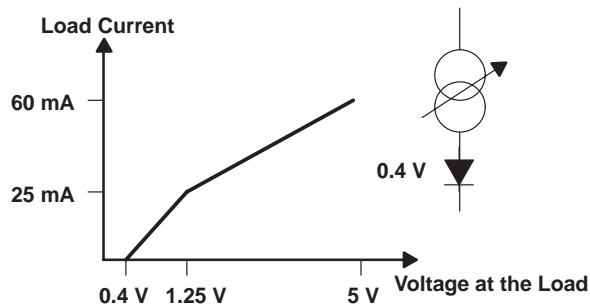

Figure 31. Maximum Start-Up Current

TPS60400, TPS60401, TPS60402, TPS60403 UNREGULATED 60-mA CHARGE PUMP VOLTAGE INVERTER

SLVS324A – JULY 2001 REVISED NOVEMBER 2004

APPLICATION INFORMATION

shutting down the TPS6040x

If shutdown is necessary, use the circuit in Figure 32. The output resistance of the TPS6040x will typically be 15 Ω plus two times the output resistance of the buffer.

Connecting multiple buffers in parallel can reduce the output resistance of the buffer driving the IN pin.

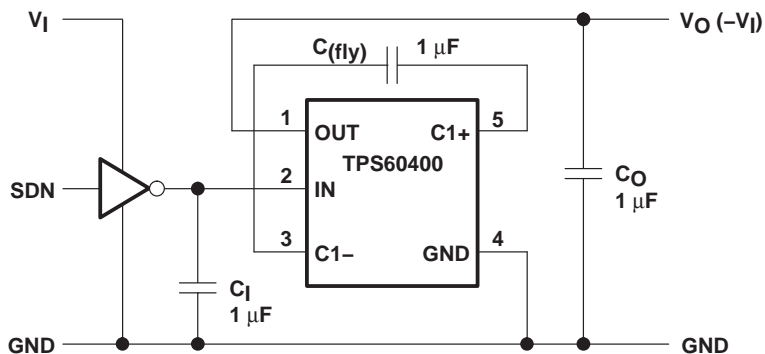

Figure 32. Shutdown Control

GaAs supply

A solution for a $-2.7\text{-V}/3\text{-mA}$ GaAs bias supply is proposed in Figure 33. The input voltage of 3.3 V is first inverted with a TPS60403 and stabilized using a TLV431 low-voltage shunt regulator. Resistor R_P with capacitor C_P is used for filtering the output voltage.

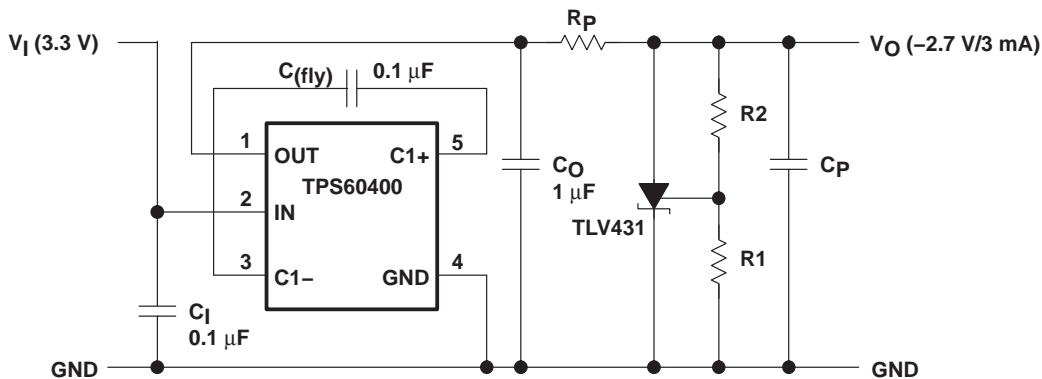

Figure 33. GaAs Supply

$$V_O = - \left(1 + \frac{R1}{R2} \right) \times V_{\text{ref}} - R1 \times I_{I(\text{ref})}$$

A 0.1-μF capacitor was selected for $C_{(\text{fly})}$. By this, the output resistance of the inverter is about 52 Ω.

APPLICATION INFORMATION

GaAs supply (continued)

R_PMAX can be calculated using the following equation:

$$R_{P\text{MAX}} = \left(\frac{V_{CO} - V_O}{I_O} - R_O \right)$$

With: V_{CO} = -3.3 V; V_O = -2.7 V; I_O = -3 mA

$$R_{P\text{MAX}} = 200 \Omega - 52 \Omega = 148 \Omega$$

A 100-Ω resistor was selected for R_P.

The reference voltage across R2 is 1.24 V typical. With 5-μA current for the voltage divider, R2 gets:

$$R2 = \frac{1.24 \text{ V}}{5 \mu\text{A}} \approx 250 \text{ k}\Omega$$

$$R1 = \frac{2.7 - 1.24 \text{ V}}{5 \mu\text{A}} \approx 300 \text{ k}\Omega$$

With C_P = 1 μF the ratio V_O/V_I of the RC post filter is:

$$\left| \frac{V_O}{V_I} \right| = \frac{1}{\sqrt{1 + (2\pi 125000\text{Hz} \times 100\Omega \times 1 \mu\text{F})^2}} \approx 0.01$$

step-down charge pump

By exchanging GND with OUT (connecting the GND pin with OUT and the OUT pin with GND), a step-down charge pump can easily be formed. In the first cycle S1 and S3 are closed, and C_(fly) with C_O in series are charged. Assuming the same capacitance, the voltage across C_(fly) and C_O is split equally between the capacitors. In the second cycle, S2 and S4 close and both capacitors with V_I/2 across are connected in parallel.

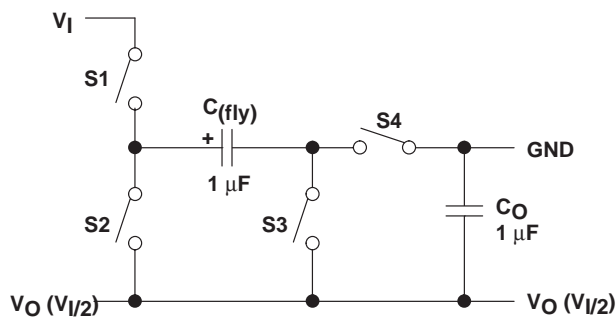

Figure 34. Step-Down Principle

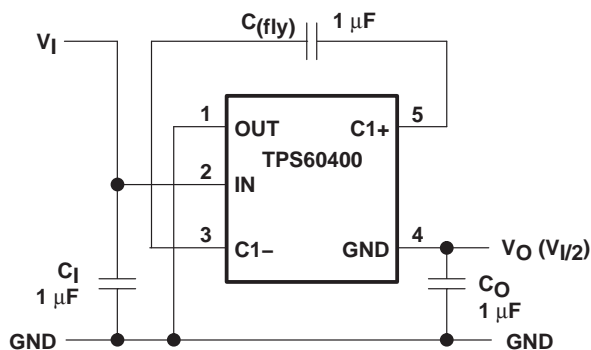

Figure 35. Step-Down Charge Pump Connection

The maximum input voltage between V_I and GND in the schematic (or between IN and OUT at the device itself) must not exceed 6.5 V. For input voltages in the range of 6.5 V to 11 V, an additional Zener-diode is recommended (see Figure 36).

TPS60400, TPS60401, TPS60402, TPS60403 UNREGULATED 60-mA CHARGE PUMP VOLTAGE INVERTER

SLVS324A – JULY 2001 REVISED NOVEMBER 2004

APPLICATION INFORMATION

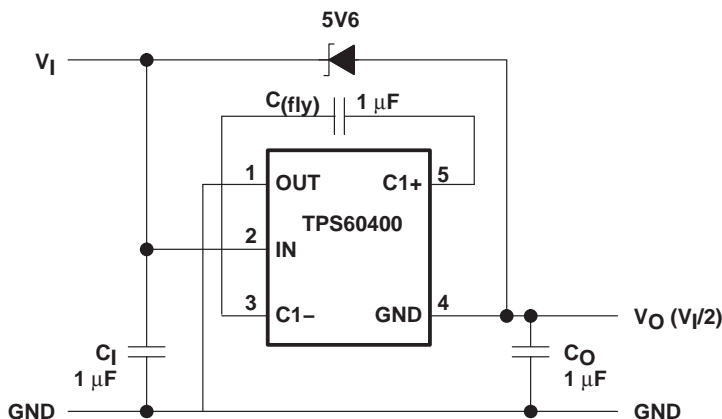

Figure 36.

power dissipation

As given in the data sheet, the thermal resistance of the unsoldered package is $R_{\theta JA} = 347^{\circ}\text{C/W}$. Soldered on the EVM, a typical thermal resistance of $R_{\theta JA(\text{EVM})} = 180^{\circ}\text{C/W}$ was measured.

The terminal resistance can be calculated using the following equation:

$$R_{\theta JA} = \frac{T_J - T_A}{P_D}$$

Where:

T_J is the junction temperature.

T_A is the ambient temperature.

P_D is the power that needs to be dissipated by the device.

$$R_{\theta JA} = \frac{T_J - T_A}{P_D}$$

The maximum power dissipation can be calculated using the following equation:

$$P_D = V_I \times I_I - V_O \times I_O = V_{I(\text{max})} \times (I_O + I_{\text{SUPPLY}}) - V_O \times I_O$$

The maximum power dissipation happens with maximum input voltage and maximum output current.

At maximum load the supply current is 0.7 mA maximum.

$$P_D = 5 \text{ V} \times (60 \text{ mA} + 0.7 \text{ mA}) - 4.4 \text{ V} \times 60 \text{ mA} = 40 \text{ mW}$$

With this maximum rating and the thermal resistance of the device on the EVM, the maximum temperature rise above ambient temperature can be calculated using the following equation:

$$\Delta T_J = R_{\theta JA} \times P_D = 180^{\circ}\text{C/W} \times 40 \text{ mW} = 7.2^{\circ}\text{C}$$

This means that the internal dissipation increases T_J by $<10^{\circ}\text{C}$.

The junction temperature of the device shall not exceed 125°C .

This means the IC can easily be used at ambient temperatures up to:

$$T_A = T_{J(\text{max})} - \Delta T_J = 125^{\circ}\text{C/W} - 10^{\circ}\text{C} = 115^{\circ}\text{C}$$

APPLICATION INFORMATION

layout and board space

All capacitors should be soldered as close as possible to the IC. A PCB layout proposal for a single-layer board is shown in Figure 37. Care has been taken to connect all capacitors as close as possible to the circuit to achieve optimized output voltage ripple performance.

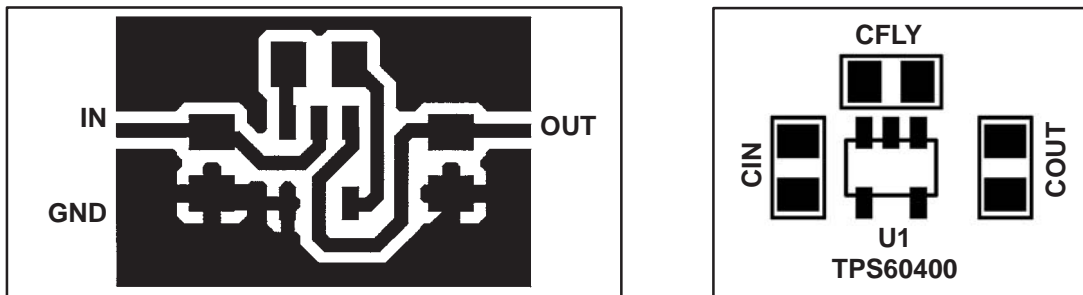

Figure 37. Recommended PCB Layout for TPS6040x (top layer)

device family products

Other inverting dc-dc converters from Texas Instruments are listed in Table 5.

Table 5. Product Identification

PART NUMBER	DESCRIPTION
TPS6735	Fixed negative 5-V, 200-mA inverting dc-dc converter
TPS6755	Adjustable 1-W inverting dc-dc converter

IMPORTANT NOTICE

Texas Instruments Incorporated and its subsidiaries (TI) reserve the right to make corrections, modifications, enhancements, improvements, and other changes to its products and services at any time and to discontinue any product or service without notice. Customers should obtain the latest relevant information before placing orders and should verify that such information is current and complete. All products are sold subject to TI's terms and conditions of sale supplied at the time of order acknowledgment.

TI warrants performance of its hardware products to the specifications applicable at the time of sale in accordance with TI's standard warranty. Testing and other quality control techniques are used to the extent TI deems necessary to support this warranty. Except where mandated by government requirements, testing of all parameters of each product is not necessarily performed.

TI assumes no liability for applications assistance or customer product design. Customers are responsible for their products and applications using TI components. To minimize the risks associated with customer products and applications, customers should provide adequate design and operating safeguards.

TI does not warrant or represent that any license, either express or implied, is granted under any TI patent right, copyright, mask work right, or other TI intellectual property right relating to any combination, machine, or process in which TI products or services are used. Information published by TI regarding third-party products or services does not constitute a license from TI to use such products or services or a warranty or endorsement thereof. Use of such information may require a license from a third party under the patents or other intellectual property of the third party, or a license from TI under the patents or other intellectual property of TI.

Reproduction of information in TI data books or data sheets is permissible only if reproduction is without alteration and is accompanied by all associated warranties, conditions, limitations, and notices. Reproduction of this information with alteration is an unfair and deceptive business practice. TI is not responsible or liable for such altered documentation.

Resale of TI products or services with statements different from or beyond the parameters stated by TI for that product or service voids all express and any implied warranties for the associated TI product or service and is an unfair and deceptive business practice. TI is not responsible or liable for any such statements.

Following are URLs where you can obtain information on other Texas Instruments products and application solutions:

Products		Applications	
Amplifiers	amplifier.ti.com	Audio	www.ti.com/audio
Data Converters	dataconverter.ti.com	Automotive	www.ti.com/automotive
DSP	dsp.ti.com	Broadband	www.ti.com/broadband
Interface	interface.ti.com	Digital Control	www.ti.com/digitalcontrol
Logic	logic.ti.com	Military	www.ti.com/military
Power Mgmt	power.ti.com	Optical Networking	www.ti.com/opticalnetwork
Microcontrollers	microcontroller.ti.com	Security	www.ti.com/security
		Telephony	www.ti.com/telephony
		Video & Imaging	www.ti.com/video
		Wireless	www.ti.com/wireless

Mailing Address: Texas Instruments
Post Office Box 655303 Dallas, Texas 75265

Copyright © 2004, Texas Instruments Incorporated