



WHITE LED CHARGE PUMP CURRENT SOURCE WITH PWM BRIGHTNESS CONTROL

FEATURES

- Regulated Output Current With 0.4% Matching
- Drives up to 3 LEDs at 25 mA Each
- LED Brightness Control Through PWM Control Signal
- High Efficiency by Fractional Conversion With 1x and 1.5x Modes
- 1 MHz Switching Frequency
- 2.7 V to 6.5 V Operating Input Voltage Range
- Internal Softstart Limits Inrush Current
- Low Input Ripple and Low EMI
- Overcurrent and Overtemperature Protected
- Undervoltage Lockout With Hysteresis
- Ultra-Small 3mm x 3mm QFN Package

APPLICATIONS

- White LED Backlight for Color Displays in Cellular Phones, Smart Phones, PDAs, Handheld PCs, Digital Cameras, and Camcorders
- Keypad Backlight

DESCRIPTION

The TPS60231 charge pump is optimized for white LED supplies in color display backlight applications. The device provides a constant current for each LED, which the initial value can be set by an external resistor. The supply voltage ranges from 2.7 V to 6.5 V and is ideally suited for all applications powered by a single LI-Ion battery cell or three to four NiCd, NiMH, or alkaline battery cells. Over an input voltage range from 3.1 V to 6.5 V, the device provides a high output current of up to 25 mA per LED with a total of 75 mA. High efficiency is achieved by utilizing a 1x/1.5x fractional conversion technique in combination with very low dropout current sources. In addition, the current controlled charge pump ensures low input current ripple and EMI. Only two external 1 μ F and two 0.47 μ F capacitors are required to build a complete small and low cost power supply solution. To reduce board space to a minimum, the device switches at 1 MHz operating frequency and is available in a small 16-pin QFN (RGT) package.

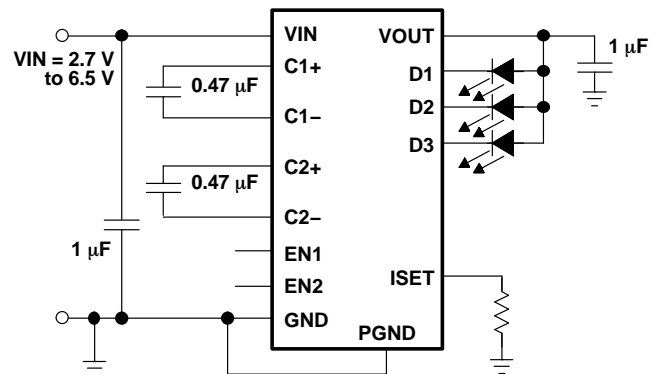

Please be aware that an important notice concerning availability, standard warranty, and use in critical applications of Texas Instruments semiconductor products and disclaimers thereto appears at the end of this data sheet.



This integrated circuit can be damaged by ESD. Texas Instruments recommends that all integrated circuits be handled with appropriate precautions. Failure to observe proper handling and installation procedures can cause damage.

ESD damage can range from subtle performance degradation to complete device failure. Precision integrated circuits may be more susceptible to damage because very small parametric changes could cause the device not to meet its published specifications.

ORDERING INFORMATION

PACKAGED DEVICE ⁽¹⁾⁽²⁾	PACKAGE	MARKING
TPS60231RGTR	QFN	BKH

- (1) T indicates shipment in tape and reel on a mini reel with 250 units per reel.
- (2) R indicates shipment in tape and reel with 3000 units per reel.

ABSOLUTE MAXIMUM RATINGS

over operating free-air temperature range (unless otherwise noted)⁽¹⁾

	UNIT
V _I Supply voltage	-0.3 V to 7 V
Voltage at EN1, EN2, VOUT, ISET	-0.3 V to V _I
Output current at VOUT	150 mA
T _J Maximum junction temperature	150°C
T _A Operating free-air temperature	-40°C to 85°C
T _{st} Storage temperature	-65°C to 150°C
Lead temperature 1,6 mm (1/16 inch) from case for 10 seconds	300°C

- (1) Stresses beyond those listed under "absolute maximum ratings" may cause permanent damage to the device. These are stress ratings only, and functional operation of the device at these or any other conditions beyond those indicated under "recommended operating conditions" is not implied. Exposure to absolute-maximum-rated conditions for extended periods may affect device reliability.

DISSIPATION RATINGS⁽¹⁾

PACKAGE	T _A ≤ 25°C POWER RATING	DERATING FACTOR ABOVE T _A = 25°C	T _A = 70°C POWER RATING	T _A = 85°C POWER RATING
16-Pin QFN (RGT)	1.9 W	20 mW/°C	1 W	760 mW

- (1) The thermal resistance junction to ambient of the QFN package is 52°C/W.

RECOMMENDED OPERATING CONDITIONS

	MIN	TYP	MAX	UNIT
Supply voltage at VIN	2.7		6.5	V
Maximum output current at VOUT	75			mA
C _i Input capacitor	1			µF
C _o Output capacitor	0.47	1		µF
Flying capacitor, C1, C2	0.22	0.47		µF
Operating junction temperature	-40		125	°C

ELECTRICAL CHARACTERISTICS
 $V_I = 3.6\text{ V}$, $EN1 = EN2 = V_I$, $T_A = -40^\circ\text{C}$ to 85°C (unless otherwise noted)

PARAMETER		TEST CONDITIONS	MIN	TYP	MAX	UNIT
SUPPLY VOLTAGE AND CURRENT						
V_I	Input voltage range	$I_O = 0\text{ mA}$ to 75 mA	2.7		6.5	V
I_Q	Operating quiescent current	$V_I = 4.2\text{ V}$, x1-mode, $EN1 = EN2 = 1$, $ISET = 20\text{ }\mu\text{A}$		200		μA
		$I_O = 0\text{ mA}$, x1.5-mode		2.1		mA
I_{SD}	Shutdown current	$EN2 = EN1 = \text{GND}$		0.1	1	μA
CHARGE PUMP STAGE						
V_{OUT}	Overvoltage limit	LED1 unconnected, $V_I = 4.2\text{ V}$		5.5		V
	Startup time	$C_O = 1\text{ }\mu\text{F}$, $I_{DX} \geq 0.9\text{ }I_{DX, \text{set}}$		375		μs
	Softstart duration			160		μs
f	Switching frequency		0.75	1	1.25	MHz
η	Efficiency	$V_I = 3.7\text{ V}$, $I_{LED} = 15\text{ mA}$ each, $V_{DX} = 3.1\text{ V}$		83%		
	Shutdown temperature	Temperature rising		160		$^\circ\text{C}$
	Shutdown temperature hysteresis			20		$^\circ\text{C}$
	Input current limit	$EN2 = EN1 = 1$, $ISET = 100\text{ }\mu\text{A}$		350		mA
CURRENT SINKS						
I_{DX}	Recommended maximum current per current sink	$3.2\text{ V} \leq V_I \leq 6.5\text{ V}$		25		mA
I_{DX}	Current into each current sink when ISET is shorted to GND	$3.0\text{ V} \leq V_I \leq 6.5\text{ V}$, ISET shorted to GND		50		mA
	Current matching between any two outputs	$V_{DX} = 3.1\text{ V}$, $T_A = 25^\circ\text{C}$	-2%	0.4%	2%	
	Line regulation	$3.2\text{ V} \leq V_I \leq 6.5\text{ V}$, $V_{DX} = 3.1\text{ V}$, $EN1 = EN2 = 1$, $ISET = 80\text{ }\mu\text{A}$			$\pm 3\%$	
V_{ISET}	Reference voltage for current set	$EN2 = 0$, $EN1 = 1$		200		mV
		$EN2 = 1$, $EN1 = 0$		400		
		$EN2 = 1$, $EN1 = 1$	580	600	620	
Iset	Recommended ISET pin current range		4		130	μA
K	I_{DX} to ISET current ratio	$EN2 = EN1 = 1$, $ISET = 80\text{ }\mu\text{A}$	230	260	280	
V_{source}	Voltage at Dx to GND	$EN2 = 0$, $EN1 = 1$		200		mV
		$EN2 = 1$, $EN1 = 0$		300		
		$EN2 = 1$, $EN1 = 1$		400		
ENABLE 1, ENABLE 2						
V_{IH}	EN1, EN2 high level input voltage		1.3			V
V_{IL}	EN1, EN2 low level input voltage				0.3	V
	EN1, EN2 trip point hysteresis			50		mV
I_{IKG}	EN2 input leakage current	$EN1, EN2 = \text{GND}$ or $EN2 = V_I$, $V_I = 6.5\text{ V}$		0.01	1	μA
I_{IKG}	EN1 input leakage current	$EN1 = V_I$, $V_I = 4.2\text{ V}$		11	15	μA
$V_{(UVLO)}$	Undervoltage lockout threshold	Input voltage falling		2.1		V
	Undervoltage lockout hysteresis			50		mV
	Frequency range at PWM		0		50	kHz
	Recommended ON-time for PWM signal			2.5		μs
	Shutdown delay time	Delay time when $EN1 = EN2$ go to GND after which the TPS60231 shuts down completely	0.5	0.85	1.5	ms

PIN ASSIGNMENT



Terminal Functions

TERMINAL NAME	NO.	I/O	DESCRIPTION
C1+	10	–	Connect to the flying capacitor C1
C1–	11	–	Connect to the flying capacitor C1
C2+	9	–	Connect to the flying capacitor C2
C2–	12	–	Connect to the flying capacitor C2
D1-D3	6-4	I	Current sink input. Connect the cathode of the white LEDs to these inputs.
EN1	15	I	Enable input. A logic high enables the converter, logic low forces the device into shutdown mode reducing the supply current to less than 1 μ A if EN2 is tied to GND.
EN2	16	I	An applied PWM signal reduces the LED current as a function of the duty cycle of the PWM signal. EN1 and EN2 can be tied together for PWM dimming between 0 mA and the maximum set with ISET. EN1 and EN2 can also be used for digital dimming with 4 steps from 0 mA to the maximum current set with ISET. See the application section for more details.
GND	14	–	Analog ground
ISET	1	I	Connect a resistor between this pin and GND to set the maximum current through the LEDs.
NC	2, 3	–	No internal connection
PGND	7	–	Power ground
VIN	13	I	Supply voltage input
VOUT	8	O	Connect the output capacitor and the anode of the LEDs to this pin.
Power PAD	–	–	Connect with PGND and GND

FUNCTIONAL BLOCK DIAGRAM

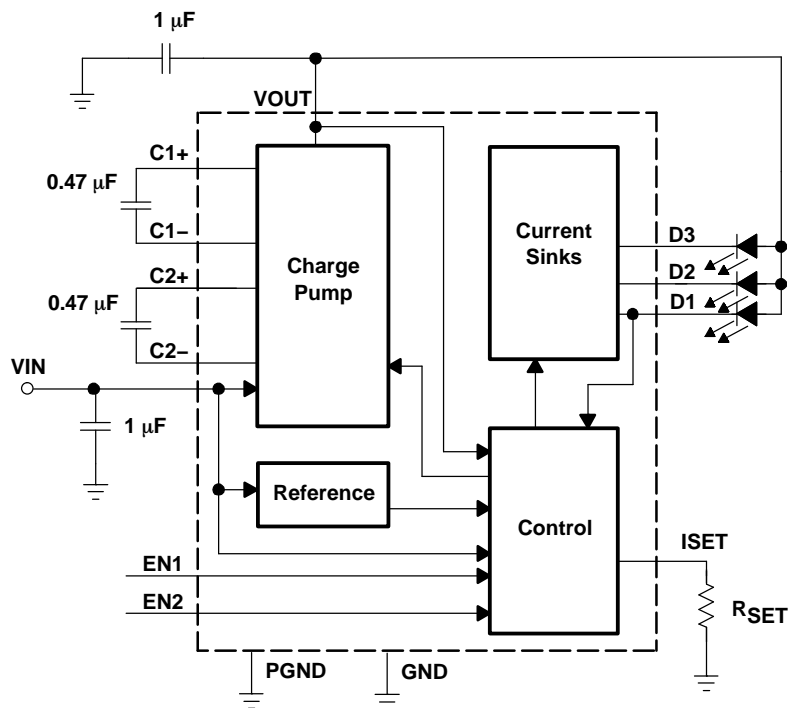

TYPICAL CHARACTERISTICS

Table of Graphs

		FIGURE
η Efficiency	vs Input voltage ($I_{LED} = 25\text{ mA}, 15\text{ mA}, 10\text{ mA}, 5\text{ mA}$ per LED), EN2 = 0, EN1 = 1	1
	vs Input voltage ($I_{LED} = 25\text{ mA}, 15\text{ mA}, 10\text{ mA}, 5\text{ mA}$ per LED), EN2 = 1, EN1 = 0	2
	vs Input voltage ($I_{LED} = 25\text{ mA}, 15\text{ mA}, 10\text{ mA}, 5\text{ mA}$ per LED), EN2 = EN1 = 1	3
I_Q Quiescent current	vs Input voltage ($T_A = -40^\circ\text{C}, 25^\circ\text{C}, 85^\circ\text{C}$) (measured with $I_{D1} = 5\text{ mA}$)	4
Maximum output current from charge pump stage	vs Input voltage ($T_A = -40^\circ\text{C}, 25^\circ\text{C}, 85^\circ\text{C}$)	5
f_s Switching frequency	vs Free-Air Temperature ($T_A = -40^\circ\text{C}$ to 85°C , $V_I = 3.6\text{ V}$)	6
LED current, I_{LED}	vs Duty cycle on PWM (I_{LED} max set to 20 mA) For $f = 32\text{ kHz}$ and $f = 1\text{ kHz}$, DC = 1% to 100%, $V_I = 3.6\text{ V}$	7
Line transient response	V_I and I_{D1} vs time on scope, LED current at D1 with $V_I = 4.2\text{ V}$ to 3.6 V to 4.2 V with EN2 = EN1 = 11, $3 \times 20\text{ mA}$	8
Dimming response	PWM signal and current at D1 vs time on scope $f = 32\text{ kHz}$ and $f = 1\text{ kHz}$, $V_I = 3.6\text{ V}$, duty cycle = 50%, EN1 = EN2 = PWM	9, 10
Startup timing	$V_I = 3.6\text{ V}$, $3 \times 20\text{ mA}$, EN1 = EN2 = 00 changed to EN2 = EN1 = 11	11

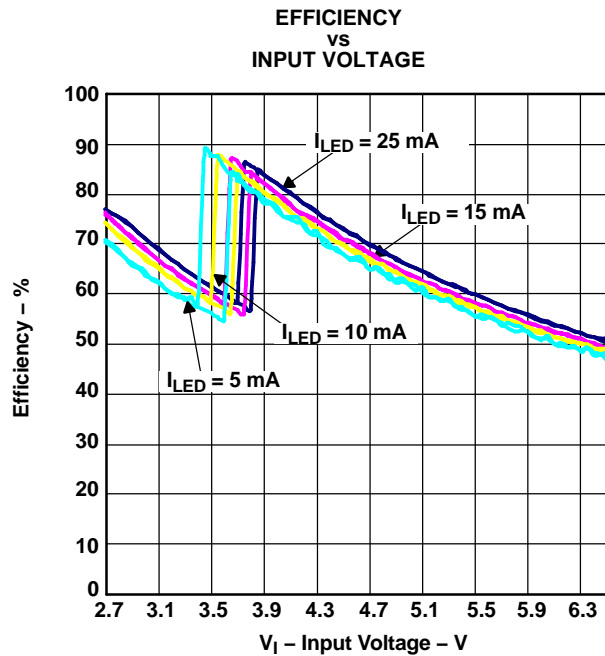

Figure 1.

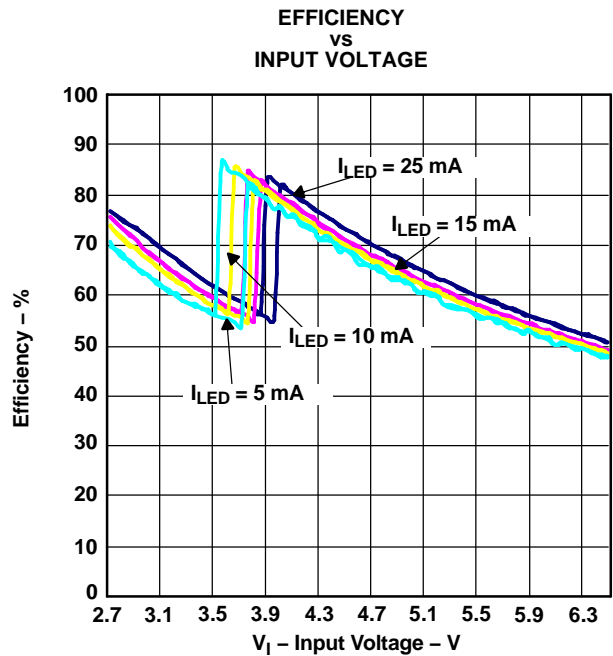

Figure 2.

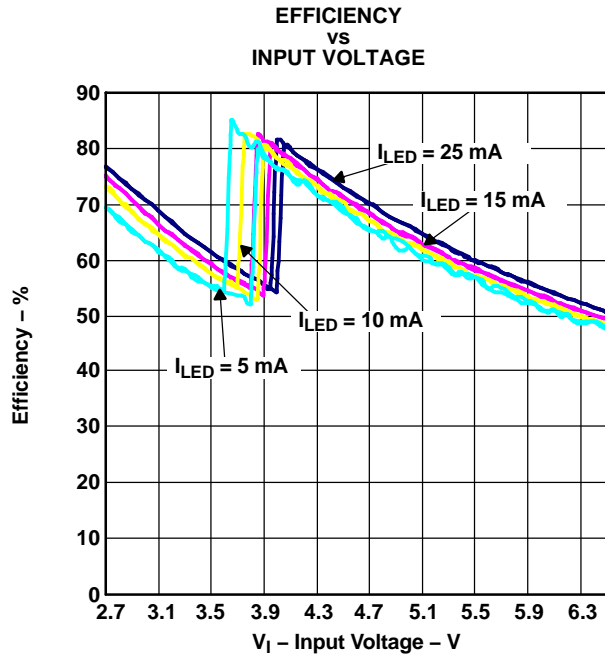

Figure 3.

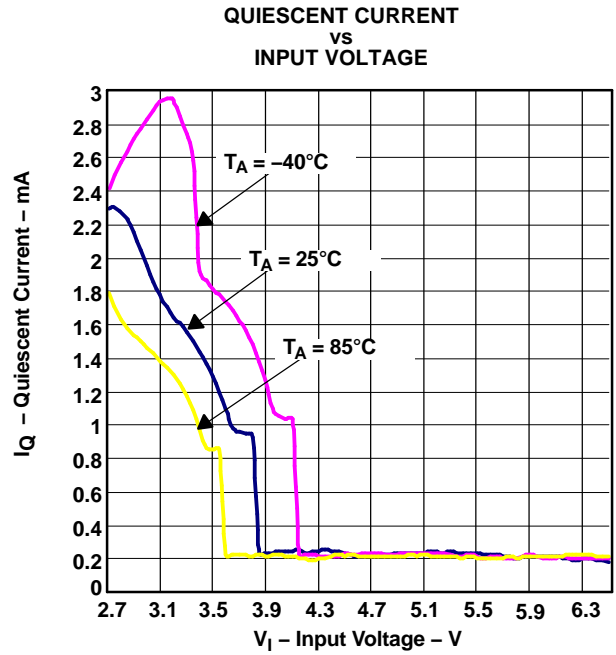

Figure 4.

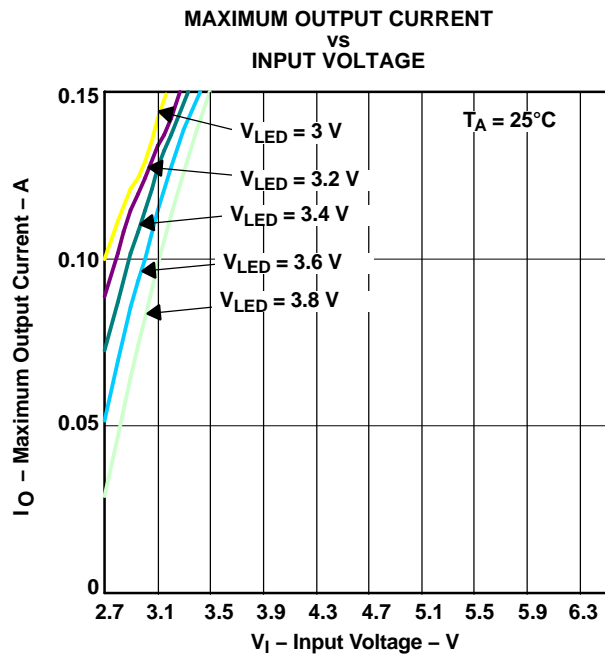

Figure 5.

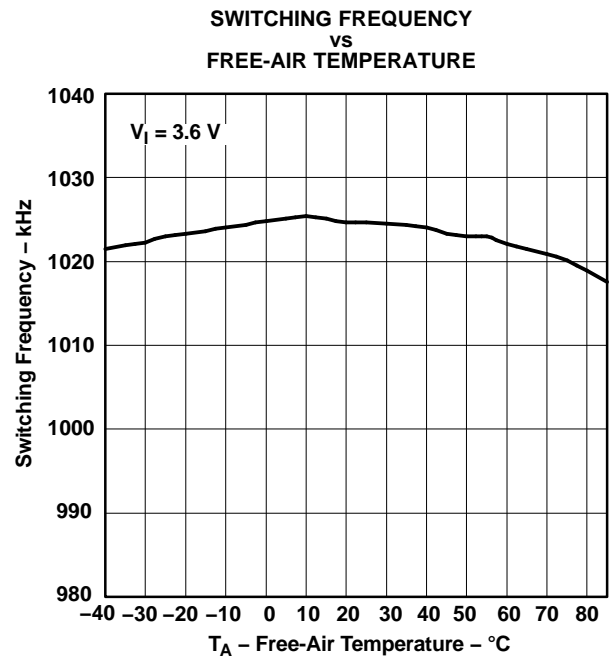

Figure 6.

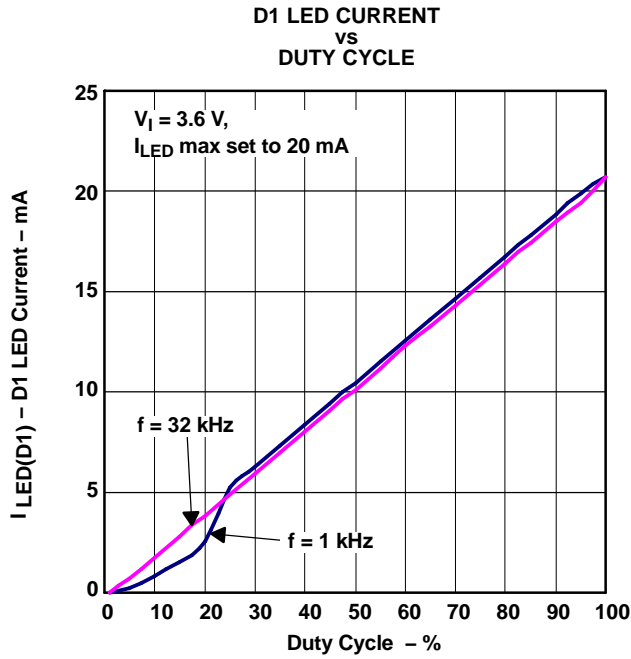

Figure 7.

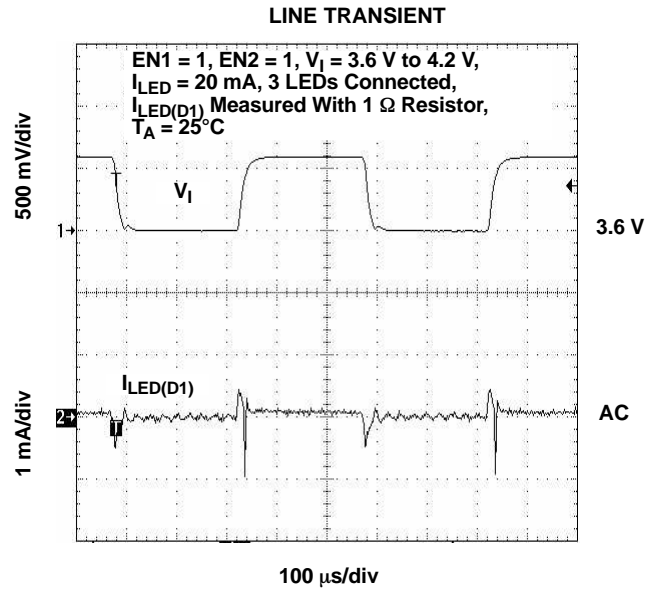

Figure 8.

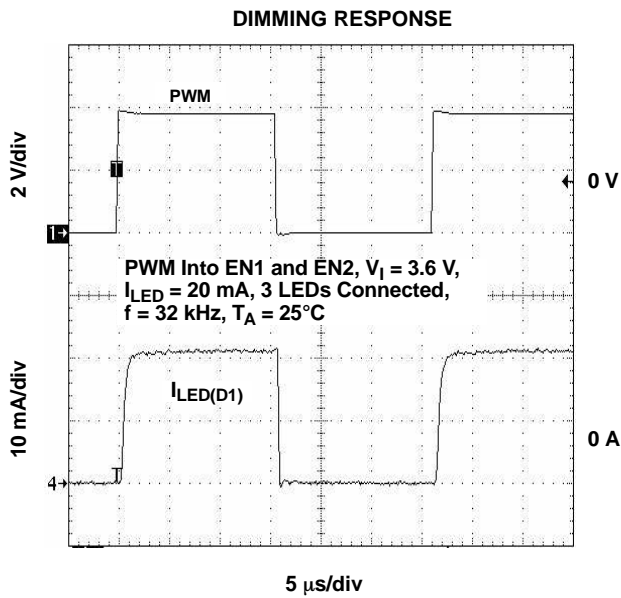

Figure 9.

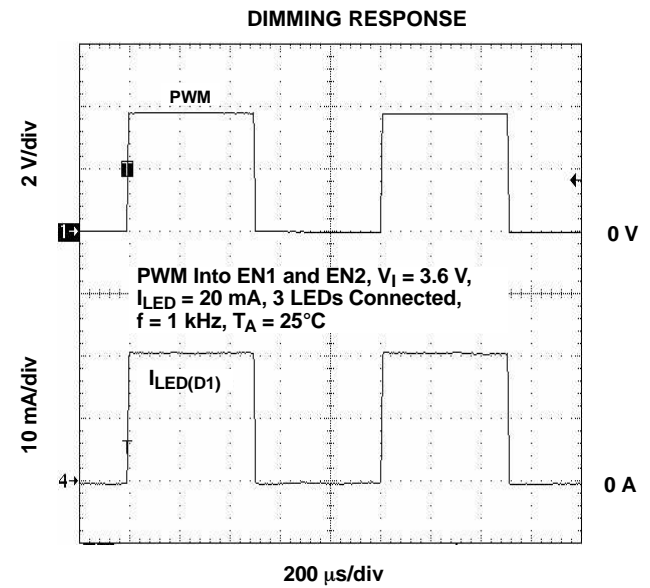

Figure 10.

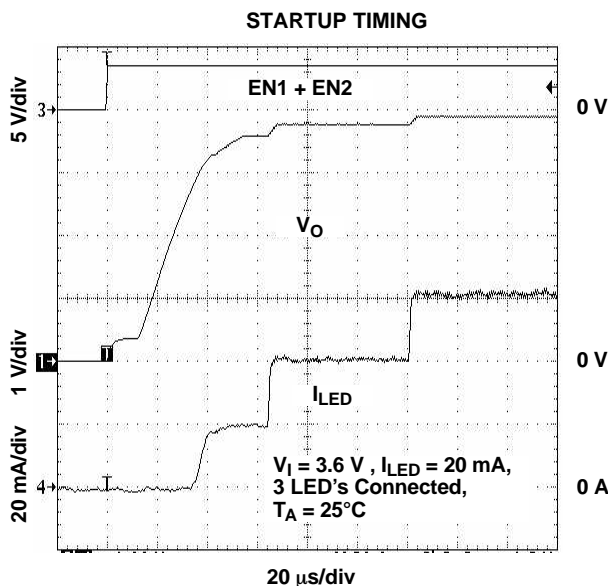

Figure 11.

DETAILED DESCRIPTION

OPERATION

The TPS60231 uses a fractional conversion charge pump to generate a supply voltage for the integrated current sinks. These current sinks are used to ensure a constant current for each LED. Depending on the input voltage and programmed LED current, the charge pump either operates in the 1x mode or in the 1.5x mode. By switching automatically between these two modes, the circuit optimizes power conversion efficiency as well as extends operating time by allowing the discharge of the battery completely.

The charge pump can generate 75 mA of output current, so each of the 3 LED outputs can be powered with up to 25 mA of current. The maximum LED current is set by a resistor connected to the ISET pin. This resistor programs a reference current, which is current mirrored to set the LED current.

Applying a PWM signal to the EN1 pin and/or the EN2 pin controls the LED brightness. See a detailed description in the section Analog Dimming Using ISET Pin.

LED CURRENT ADJUSTMENT (ISET)

A resistor programs a reference current, which is current mirrored to set the LED current. The voltage at the ISET pin depends on the status of EN1 and EN2. The current in each LED is typically 260 times the current through the resistor at ISET.

$$R_{\text{ISET}} = \frac{V_{\text{ISET}}}{I_{\text{LED}}} \times K$$

V_{ISET} — Voltage from ISET pin (0.2 V, 0.4 V or 0.6 V) to GND, see Table 1

I_{LED} — Current per LED from Dx pin to GND

K — Dx to I_{SET} current ratio (typically 260)

The LED current varies linearly from 0 mA to $I_{\text{LED(max)}}$ mA by applying a PMW signal with 0% to 100% duty cycle. The LED brightness can however also be controlled by an analog control signal that is fed into the ISET pin.

DETAILED DESCRIPTION (continued)

SOFT START

The TPS60231 has an internal soft start circuit to limit the inrush current during startup. This prevents possible voltage drops of the input voltage if a high impedance power source is connected to the input of the TPS60231. When the device starts up with an output voltage that is below the input voltage, the output capacitor is charged directly from the input with a current source. The output current increases linearly until the output reaches within 300 mV of the input voltage. When the programmed output current can be reached with the 1x mode, the TPS60231 terminates the soft start and begins normal operation. When the desired output current cannot be reached, the charge pump begins operation in 1.5x mode and pumps the output voltage up to the needed level to reach the programmed output current.

ENABLE (EN1, EN2)

The enable pins EN1 and EN2 are used to enable the device or set it into shutdown. The TPS60231 is enabled if one of the enable pins is pulled higher than the enable trip point of 1.3 V. The device starts up by going through the soft start routine as described in the section Soft Start. Pulling both pins to GND, after a delay, programs the device to shutdown. In shutdown, the charge pump, current sources, voltage reference, oscillator, and all other functions are turned off and the supply current is reduced to 0.1 μ A.

EN1 and EN2 can also be used for dimming. The logic levels at EN1 and EN2 set the minimum voltage at the current mirrors and the voltage at the ISET pin to GND. This sets the current at the LEDs to be either the full current or a fraction of the full current. See Table 1 for further details. The maximum current through the LEDs is set by a resistor connected between ISET and GND.

EN1 and EN2 can also be used for PWM dimming. The PWM signal can either be applied to EN1 or EN2, or both inputs can be tied together and the PWM signal can be applied to both pins. Depending on the configuration, the current during PWM dimming is switched between 0 mA and its maximum (EN1 and EN2 connected to the PWM signal) or between 0 mA and 1/3 of the full LED current if EN2 = 0 and EN1 is toggled. When EN1 = 0 and EN2 is toggled, the output current can be changed between 0 mA and 2/3 of the full range.

Table 1. Enable Levels

ENABLE LEVEL		MODE	LED CURRENT
EN2	EN1		
0	0	SHUTDOWN	0
0	1	VISET = 200 mV	1/3
1	0	VISET = 400 mV	2/3
1	1	VISET = 600 mV	Full

UNDERVOLTAGE LOCKOUT

The undervoltage lockout circuit shuts down the device when the voltage at VIN drops below a typical threshold of 2.15 V. This prevents damage to the device. The UVLO circuit allows the device to start up again after the voltage on the VIN pin has increased by about 50 mV above the UVLO lockout threshold.

SHORT CIRCUIT AND OVERTEMPATURE PROTECTION

The current at the VOUT pin is limited typically to 250 mA. When the junction temperature exceeds 160°C, the device shuts down to protect the device from damage. After the temperature decreases to about 140°C, the device starts up again if it is enabled.

OVERTVOLTAGE PROTECTION AT VOUT

The device uses the voltage at D1 to regulate voltage at VOUT. In case D1 is not connected, an overvoltage protection circuit ensures that the output voltage at VOUT does not exceed its limits. The connection of the LEDs must be started using D1 first. For all other LEDs there is no restriction in the sequence. For example, if there are only 2 LEDs used, the first LED is connected to D1 and the other LED can be connected to any other of the D2 to D3 pins.

THEORY OF OPERATION/DESIGN PROCEDURE

Capacitor Selection

Ceramic capacitors such as X5R or X7R are recommended to be used with the TPS60231. For the two flying capacitors C1 and C2, it is important to use low ESR capacitors to avoid unnecessary efficiency losses. Low ESR capacitors on VOUT reduce the ripple voltage on the supply of the current sources. Table 2 lists capacitor types that have been tested with the TPS60231.

Table 2. Capacitors

PART	VALUE	VOLTAGE	MANUFACTURER	SIZE	WEBSITE
C1608X5R1A105M	1 μ F	10 V	TDK	0603	www.component.tdk.com
C1608X5R1A474M	0.47 μ F	10 V		0603	
C2012X7R1C105M	1 μ F	16 V		0805	
LMK107BJ105MA	1 μ F	10 V	Taiyo Yuden	0603	www.t-yuden.com
LMK107BJ474MA	0.47 μ F	10 V		0603	
LMK212BJ105MG	1 μ F	10 V		0805	

Power Efficiency

The power conversion efficiency of the TPS60231 can be calculated by adding up the products of each LED current and voltage and dividing it by the product of the input voltage and current. With a fully charged battery where the input voltage is typically above the LED forward voltage, the charge pump operates in the 1x mode and efficiency is very high. As the battery discharges, there is a point where the current sources no longer have enough voltage overhead to maintain a constant current regulation. At that point, the charge pump switches into the 1.5x mode. The conversion efficiency is lowest at the crossover. As the battery discharges further, the efficiency again increases until at about 3.1 V where it reaches a second maximum. Below 3.1 V input voltage, the maximum current per LED is less than 25 mA.

Power Dissipation

The maximum power dissipation inside the TPS60231 can be calculated based on the following equation:

$$P_{D \max} = [(1.5 \times V_I) - V_O + 0.4 \text{ V}] \times I_O$$

The maximum power dissipation occurs when the input voltage is just low enough to operate in 1.5x mode, with a forward voltage of the white LED at maximum. This is typically for $V_I = 4.2 \text{ V}$ and a forward voltage of 3.6 V.

This needs to be lower than the maximum allowed power dissipation of the package, which can be calculated using the following equation:

$$P_{D \max, \text{ package}} = \frac{T_{J\max} - T_A}{R_{\theta ja}}$$

For example, the worst case power dissipation occurs at the input voltage level where the charge pump switches from the 1x mode to the 1.5x mode. At this operating point, the supply voltage to the current sources is at its maximum and the current sources must drop the most voltage in order to maintain a regulated output current. The worst case power dissipation occurs when all 3 LED outputs are fully loaded with 25 mA of LED current.

- With: $V_I = 4.2 \text{ V}$, $V_f = 3.6 \text{ V}$, $I_O = 75 \text{ mA}$ (1.5x mode)
- $P_{D \max} = 0.23 \text{ W}$

APPLICATION INFORMATION

TYPICAL APPLICATION OF A SMART PHONE DISPLAY WITH RESISTORS CONNECTED IN PARALLEL

If more than 25 mA of output current is needed, then the input pins to the current sinks can be connected in parallel as shown in the following application figure. This method can also be used to connect a LC display with only two connections for the white LEDs.

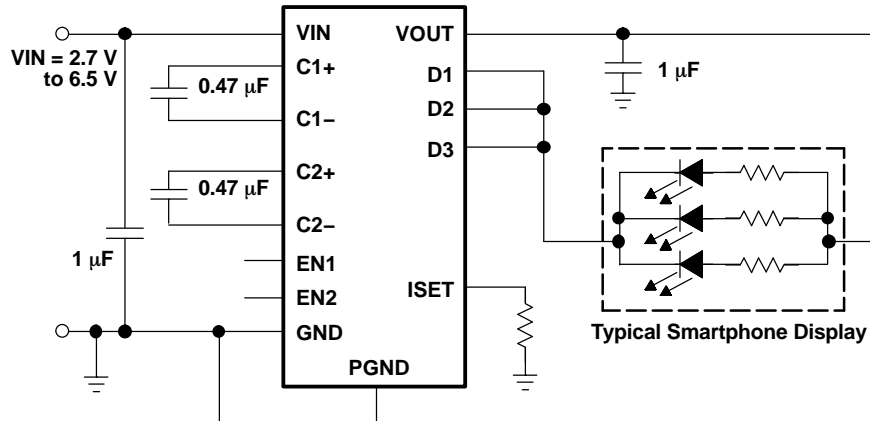

Figure 12. Typical Application With Resistors in Parallel

ANALOG DIMMING USING ISET PIN

The ISET pin can be used to connect an analog dc signal in the range of 0 mV to 600 mV (EN1 = EN2 = 1) for analog dimming of the white LEDs. For an input voltage of 0 V at ISET, the current is at its maximum, whereas at 600 mV, the LED current is zero. The maximum current is:

- For EN2 = EN1 = 1: $I_{LED} = V_{set}/R_{set} \times K = 0.6V/6k\Omega \times 260 = 26 \text{ mA per LED}$
- For EN2 = 1, EN0 = 1: $I_{LED} = V_{set}/R_{set} \times K = 0.4V/6k\Omega \times 260 = 17 \text{ mA per LED}$
- For EN2 = 0, EN1 = 1: $I_{LED} = V_{set}/R_{set} \times K = 0.2V/6k\Omega \times 260 = 8.6 \text{ mA per LED}$
- With EN2, EN1 set to 10 or 01, a voltage of 400 mV or 200 mV is required to set the LED current to zero.

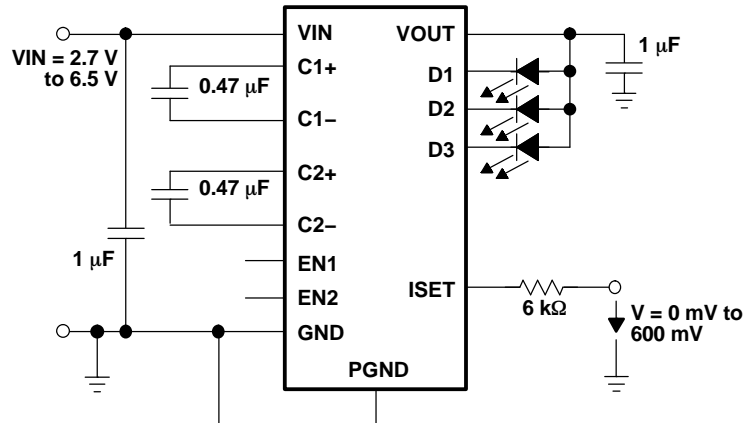

Figure 13. Analog Dimming Connections Using ISET Pin

APPLICATION INFORMATION (continued)

TYPICAL APPLICATION USING 2 WHITE LEDs AND 6 GREEN LEDs FOR LCD BACKLIGHT AND KEYBOARD LIGHTING

The TPS60231 can be used to power any kind of LED. It is also possible to mix white LEDs with color LEDs which have a lower forward voltage. The LED with the highest forward voltage (typically the white LED) has to be connected to D1, because the output voltage of the charge pump is regulated in such a way to keep the voltage drop from D1 to GND at 400mV (with EN1 = EN2 = 1). Therefore the output voltage of the charge pump is regulated to:

$$V_{OUT} = V_{D1} + V_{FLEDD1}$$

V_{OUT} — Output voltage at VOUT

V_{D1} — Voltage from D1 to GND (V_{source} at D1 pin, see electrical characteristics)

V_{FLEDD1} — Forward voltage of the LED connected to D1

Resistor R_g is used to provide current sharing between the 6 green LEDs. The upper value is calculated using:

$$R_g = \frac{V_{FLEDD1} - V_{Fg}}{I_g}$$

V_{Fg} — Forward voltage of a green LED

I_g — Current per green LED

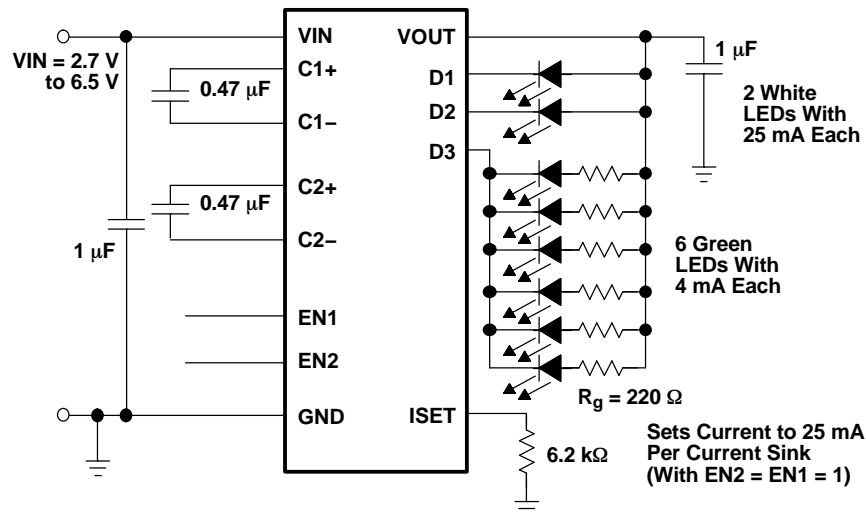

Figure 14. LED Connections for LCD Backlight and Keyboard Lighting

PROPOSED LAND PATTERN FOR PCB PRODUCTION

Refer to the application note SLUA271 for the proposed land pattern of the QFN package.

PACKAGING INFORMATION

Orderable Device	Status ⁽¹⁾	Package Type	Package Drawing	Pins	Package Qty	Eco Plan ⁽²⁾	Lead/Ball Finish	MSL Peak Temp ⁽³⁾
TPS60231RGTR	ACTIVE	QFN	RGT	16	3000	Green (RoHS & no Sb/Br)	CU NIPDAU	Level-2-260C-1 YEAR
TPS60231RGTRG4	ACTIVE	QFN	RGT	16	3000	Green (RoHS & no Sb/Br)	CU NIPDAU	Level-2-260C-1 YEAR
TPS60231RGTT	ACTIVE	QFN	RGT	16	250	Green (RoHS & no Sb/Br)	CU NIPDAU	Level-2-260C-1 YEAR
TPS60231RGTTG4	ACTIVE	QFN	RGT	16	250	Green (RoHS & no Sb/Br)	CU NIPDAU	Level-2-260C-1 YEAR

⁽¹⁾ The marketing status values are defined as follows:

ACTIVE: Product device recommended for new designs.

LIFEBUY: TI has announced that the device will be discontinued, and a lifetime-buy period is in effect.

NRND: Not recommended for new designs. Device is in production to support existing customers, but TI does not recommend using this part in a new design.

PREVIEW: Device has been announced but is not in production. Samples may or may not be available.

OBSOLETE: TI has discontinued the production of the device.

⁽²⁾ Eco Plan - The planned eco-friendly classification: Pb-Free (RoHS), Pb-Free (RoHS Exempt), or Green (RoHS & no Sb/Br) - please check <http://www.ti.com/productcontent> for the latest availability information and additional product content details.

TBD: The Pb-Free/Green conversion plan has not been defined.

Pb-Free (RoHS): TI's terms "Lead-Free" or "Pb-Free" mean semiconductor products that are compatible with the current RoHS requirements for all 6 substances, including the requirement that lead not exceed 0.1% by weight in homogeneous materials. Where designed to be soldered at high temperatures, TI Pb-Free products are suitable for use in specified lead-free processes.

Pb-Free (RoHS Exempt): This component has a RoHS exemption for either 1) lead-based flip-chip solder bumps used between the die and package, or 2) lead-based die adhesive used between the die and leadframe. The component is otherwise considered Pb-Free (RoHS compatible) as defined above.

Green (RoHS & no Sb/Br): TI defines "Green" to mean Pb-Free (RoHS compatible), and free of Bromine (Br) and Antimony (Sb) based flame retardants (Br or Sb do not exceed 0.1% by weight in homogeneous material)

⁽³⁾ MSL, Peak Temp. -- The Moisture Sensitivity Level rating according to the JEDEC industry standard classifications, and peak solder temperature.

Important Information and Disclaimer:The information provided on this page represents TI's knowledge and belief as of the date that it is provided. TI bases its knowledge and belief on information provided by third parties, and makes no representation or warranty as to the accuracy of such information. Efforts are underway to better integrate information from third parties. TI has taken and continues to take reasonable steps to provide representative and accurate information but may not have conducted destructive testing or chemical analysis on incoming materials and chemicals. TI and TI suppliers consider certain information to be proprietary, and thus CAS numbers and other limited information may not be available for release.

In no event shall TI's liability arising out of such information exceed the total purchase price of the TI part(s) at issue in this document sold by TI to Customer on an annual basis.

TAPE AND REEL INFORMATION



QUADRANT ASSIGNMENTS FOR PIN 1 ORIENTATION IN TAPE



*All dimensions are nominal

Device	Package Type	Package Drawing	Pins	SPQ	Reel Diameter (mm)	Reel Width W1 (mm)	A0 (mm)	B0 (mm)	K0 (mm)	P1 (mm)	W (mm)	Pin1 Quadrant
TPS60231RGTR	QFN	RGT	16	3000	330.0	12.4	3.3	3.3	1.1	8.0	12.0	Q2
TPS60231RGTR	QFN	RGT	16	3000	330.0	12.4	3.3	3.3	1.0	8.0	12.0	Q2
TPS60231RGTT	QFN	RGT	16	250	330.0	12.4	3.3	3.3	1.0	8.0	12.0	Q2
TPS60231RGTT	QFN	RGT	16	250	180.0	12.4	3.3	3.3	1.1	8.0	12.0	Q2

TAPE AND REEL BOX DIMENSIONS

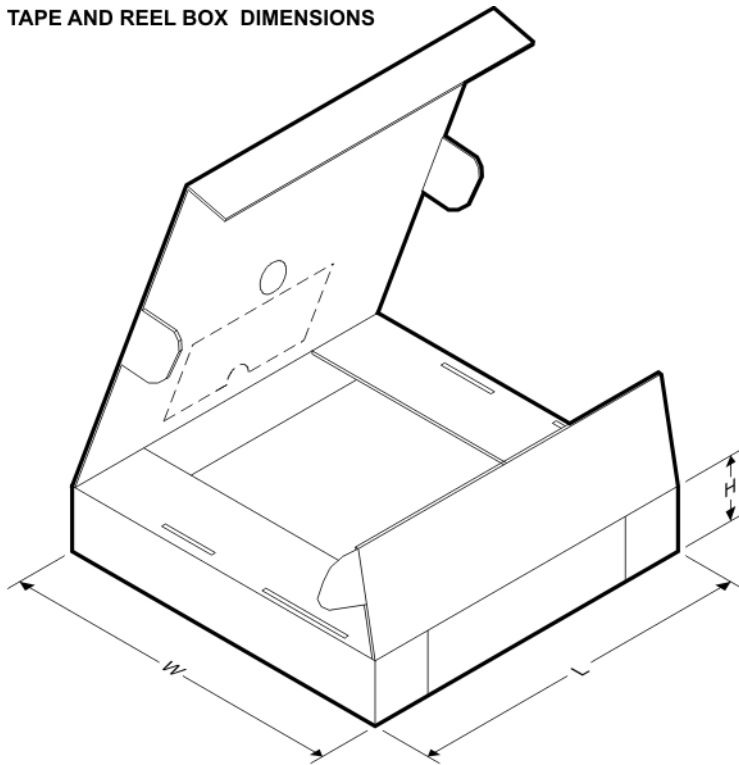

*All dimensions are nominal

Device	Package Type	Package Drawing	Pins	SPQ	Length (mm)	Width (mm)	Height (mm)
TPS60231RGTR	QFN	RGT	16	3000	346.0	346.0	29.0
TPS60231RGTR	QFN	RGT	16	3000	370.0	355.0	55.0
TPS60231RGTT	QFN	RGT	16	250	370.0	355.0	55.0
TPS60231RGTT	QFN	RGT	16	250	190.5	212.7	31.8

THERMAL INFORMATION

This package incorporates an exposed thermal pad that is designed to be attached directly to an external heatsink. The thermal pad must be soldered directly to the printed circuit board (PCB). After soldering, the PCB can be used as a heatsink. In addition, through the use of thermal vias, the thermal pad can be attached directly to the appropriate copper plane shown in the electrical schematic for the device, or alternatively, can be attached to a special heatsink structure designed into the PCB. This design optimizes the heat transfer from the integrated circuit (IC).

For information on the Quad Flatpack No-Lead (QFN) package and its advantages, refer to Application Report, Quad Flatpack No-Lead Logic Packages, Texas Instruments Literature No. SCBA017. This document is available at www.ti.com.

The exposed thermal pad dimensions for this package are shown in the following illustration.

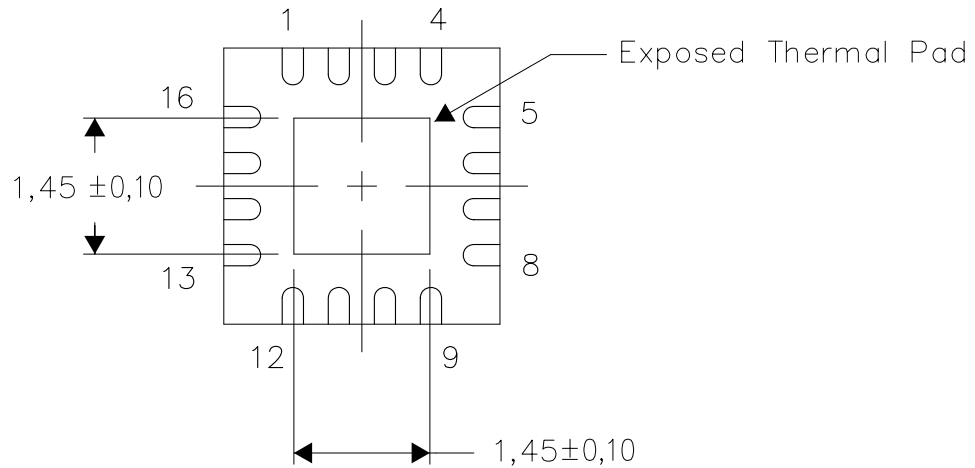

Bottom View

NOTE: All linear dimensions are in millimeters

Exposed Thermal Pad Dimensions

IMPORTANT NOTICE

Texas Instruments Incorporated and its subsidiaries (TI) reserve the right to make corrections, modifications, enhancements, improvements, and other changes to its products and services at any time and to discontinue any product or service without notice. Customers should obtain the latest relevant information before placing orders and should verify that such information is current and complete. All products are sold subject to TI's terms and conditions of sale supplied at the time of order acknowledgment.

TI warrants performance of its hardware products to the specifications applicable at the time of sale in accordance with TI's standard warranty. Testing and other quality control techniques are used to the extent TI deems necessary to support this warranty. Except where mandated by government requirements, testing of all parameters of each product is not necessarily performed.

TI assumes no liability for applications assistance or customer product design. Customers are responsible for their products and applications using TI components. To minimize the risks associated with customer products and applications, customers should provide adequate design and operating safeguards.

TI does not warrant or represent that any license, either express or implied, is granted under any TI patent right, copyright, mask work right, or other TI intellectual property right relating to any combination, machine, or process in which TI products or services are used. Information published by TI regarding third-party products or services does not constitute a license from TI to use such products or services or a warranty or endorsement thereof. Use of such information may require a license from a third party under the patents or other intellectual property of the third party, or a license from TI under the patents or other intellectual property of TI.

Reproduction of TI information in TI data books or data sheets is permissible only if reproduction is without alteration and is accompanied by all associated warranties, conditions, limitations, and notices. Reproduction of this information with alteration is an unfair and deceptive business practice. TI is not responsible or liable for such altered documentation. Information of third parties may be subject to additional restrictions.

Resale of TI products or services with statements different from or beyond the parameters stated by TI for that product or service voids all express and any implied warranties for the associated TI product or service and is an unfair and deceptive business practice. TI is not responsible or liable for any such statements.

TI products are not authorized for use in safety-critical applications (such as life support) where a failure of the TI product would reasonably be expected to cause severe personal injury or death, unless officers of the parties have executed an agreement specifically governing such use. Buyers represent that they have all necessary expertise in the safety and regulatory ramifications of their applications, and acknowledge and agree that they are solely responsible for all legal, regulatory and safety-related requirements concerning their products and any use of TI products in such safety-critical applications, notwithstanding any applications-related information or support that may be provided by TI. Further, Buyers must fully indemnify TI and its representatives against any damages arising out of the use of TI products in such safety-critical applications.

TI products are neither designed nor intended for use in military/aerospace applications or environments unless the TI products are specifically designated by TI as military-grade or "enhanced plastic." Only products designated by TI as military-grade meet military specifications. Buyers acknowledge and agree that any such use of TI products which TI has not designated as military-grade is solely at the Buyer's risk, and that they are solely responsible for compliance with all legal and regulatory requirements in connection with such use.

TI products are neither designed nor intended for use in automotive applications or environments unless the specific TI products are designated by TI as compliant with ISO/TS 16949 requirements. Buyers acknowledge and agree that, if they use any non-designated products in automotive applications, TI will not be responsible for any failure to meet such requirements.

Following are URLs where you can obtain information on other Texas Instruments products and application solutions:

Products

Amplifiers	amplifier.ti.com
Data Converters	dataconverter.ti.com
DSP	dsp.ti.com
Clocks and Timers	www.ti.com/clocks
Interface	interface.ti.com
Logic	logic.ti.com
Power Mgmt	power.ti.com
Microcontrollers	microcontroller.ti.com
RFID	www.ti-rfid.com
RF/IF and ZigBee® Solutions	www.ti.com/lprf

Applications

Audio	www.ti.com/audio
Automotive	www.ti.com/automotive
Broadband	www.ti.com/broadband
Digital Control	www.ti.com/digitalcontrol
Medical	www.ti.com/medical
Military	www.ti.com/military
Optical Networking	www.ti.com/opticalnetwork
Security	www.ti.com/security
Telephony	www.ti.com/telephony
Video & Imaging	www.ti.com/video
Wireless	www.ti.com/wireless

Mailing Address: Texas Instruments, Post Office Box 655303, Dallas, Texas 75265
Copyright © 2008, Texas Instruments Incorporated