

4.5-V TO 60-V WIDE-INPUT SYNCHRONOUS PWM BUCK CONTROLLER

Check for Samples: [TPS40170](#)

FEATURES

- **Wide-Input Voltage Range from 4.5 V to 60 V**
- **600-mV Reference Voltage with 1% Accuracy**
- **Programmable UVLO and Hysteresis**
- **Voltage Mode Control With Voltage Feed Forward**
- **Programmable Frequency Between 100 kHz and 600 kHz**
- **Bi-directional -Frequency Synchronization With Master/Slave Option**
- **Low-side FET Sensing Overcurrent Protection and High-Side FET Sensing Short-Circuit Protection With Integrated Thermal Compensation**
- **Programmable Closed Loop Soft-Start**
- **Supports Pre-Biased Outputs**
- **Thermal Shutdown at 165°C with Hysteresis**
- **Voltage Tracking**
- **Power Good**
- **ENABLE with 1- μ A Low-Current Shutdown**
- **8.0-V and 3.3-V LDO Output**
- **Integrated Bootstrap Diode**
- **20-Pin 3.5 mm \times 4.5 mm QFN (RGY) Package**

APPLICATIONS

- **POL Modules**
- **Wide Input Voltage, High-Power Density DC/DC Converters for Industrial, Networking and Telecomm Equipment**

DESCRIPTION

TPS40170 is a full-featured, synchronous PWM buck controller that operates at an input voltage between 4.5 V and 60 V and is optimized for high-power-density, high-reliability DC/DC converter applications. The controller implements voltage-mode control with input-voltage feed-forward compensation that enables instant response to input voltage change. The switching frequency is programmable from 100 kHz to 600 kHz.

The TPS40170 has a complete set of system protection and monitoring features such as programmable UVLO, programmable overcurrent protection (OCP) by sensing the low-side FET, selectable short-circuit protection (SCP) by sensing the high-side FET and thermal shutdown. The ENABLE pin allows for system shutdown in a low-current (1- μ A typical) mode. The controller supports pre-biased output, provides an open-drain PGOOD signal, and has closed loop soft-start, output voltage tracking and adaptive dead-time control.

TPS40170 provides accurate output voltage regulation via 1% ensured accuracy. Additionally, the controller implements a novel scheme of bi-directional synchronization with one controller acting as the master and other downstream controllers acting as slaves synchronized to the master in-phase or 180° out-of-phase. Slave controllers can be synchronized to an external clock within $\pm 30\%$ of the free running switching frequency.



Please be aware that an important notice concerning availability, standard warranty, and use in critical applications of Texas Instruments semiconductor products and disclaimers thereto appears at the end of this data sheet.

SIMPLIFIED APPLICATION

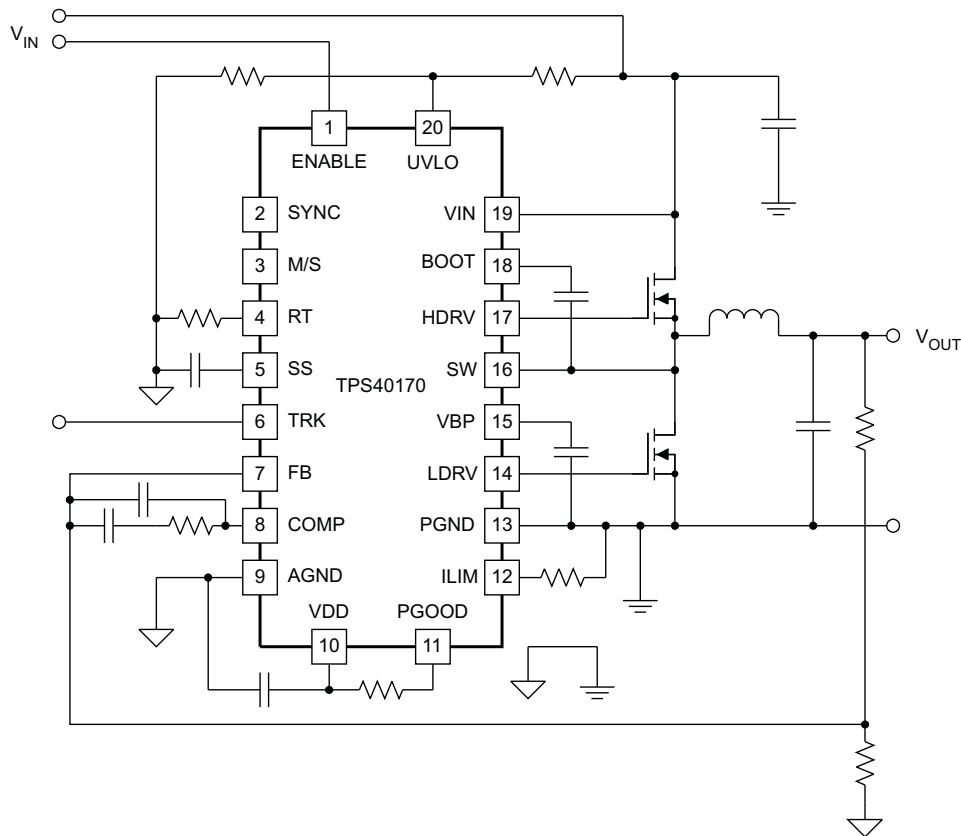

UDG-09219



This integrated circuit can be damaged by ESD. Texas Instruments recommends that all integrated circuits be handled with appropriate precautions. Failure to observe proper handling and installation procedures can cause damage.

ESD damage can range from subtle performance degradation to complete device failure. Precision integrated circuits may be more susceptible to damage because very small parametric changes could cause the device not to meet its published specifications.

ORDERING INFORMATION⁽¹⁾⁽²⁾

T _J	PACKAGE	PINS	TRANSPORT MEDIA	QUANTITY	DEVICE NUMBER
-40°C to 125°C	Plastic QFN	20	Tape and Reel (small)	250	TPS40170RGYT
			Tape and Reel (large)	3000	TPS40170RGYR

- (1) For the most current package and ordering information see the *Package Option Addendum* at the end of this document, or see the TI web site at www.ti.com.
- (2) Package drawings, thermal data, and symbolization are available at www.ti.com/packaging

ABSOLUTE MAXIMUM RATINGS

over operating free-air temperature range (unless otherwise noted)

		VALUE		
		MIN	MAX	UNIT
Input voltage	VIN	-0.3	62	V
	M/S	-0.3	VIN	
	UVLO	-0.3	16	
	SW	-5	VIN	
	BOOT		V _{SW} + 8.8	
Output voltage	HDRV	V _{SW}	BOOT	V
	BOOT-SW, HDRV-SW (differential from BOOT or HDRV to SW)	-0.3	8.8	
	VBP, LDRV, COMP, RT, ENABLE, PGOOD, SYNC	-0.3	8.8	
	VDD, FB, TRK, SS, ILIM	-0.3	3.6	
Electrostatic discharge (ESD)	AGND-PGND, PGND-AGND	200	200	mV
	PowerPAD to AGND (must be electrically connected external to device)		0	
Lead Temperature	Human body model (HBM)		2	kV
	Charge device model (CDM)		1	
Operating junction temperature range	T _J	-40	125	°C
Storage temperature	T _{stg}	-55	150	°C

THERMAL INFORMATION

THERMAL METRIC ⁽¹⁾		TPS40170	UNITS
		RGY	
		20 PINS	
θ _{JA}	Junction-to-ambient thermal resistance ⁽²⁾	35.0	°C/W
θ _{JC(top)}	Junction-to-case(top) thermal resistance ⁽³⁾	36.7	
θ _{JB}	Junction-to-board thermal resistance ⁽⁴⁾	12.6	
ψ _{JT}	Junction-to-top characterization parameter ⁽⁵⁾	0.4	
ψ _{JB}	Junction-to-board characterization parameter ⁽⁶⁾	12.7	
θ _{JC(bottom)}	Junction-to-case(bottom) thermal resistance ⁽⁷⁾	3.1	

(1) For more information about traditional and new thermal metrics, see the *IC Package Thermal Metrics* application report, [SPRA953](#).

(2) The junction-to-ambient thermal resistance under natural convection is obtained in a simulation on a JEDEC-standard, high-K board, as specified in JESD51-7, in an environment described in JESD51-2a.

(3) The junction-to-case (top) thermal resistance is obtained by simulating a cold plate test on the package top. No specific JEDEC standard test exists, but a close description can be found in the ANSI SEMI standard G30-88.

(4) The junction-to-board thermal resistance is obtained by simulating in an environment with a ring cold plate fixture to control the PCB temperature, as described in JESD51-8.

(5) The junction-to-top characterization parameter, ψ_{JT}, estimates the junction temperature of a device in a real system and is extracted from the simulation data for obtaining θ_{JA}, using a procedure described in JESD51-2a (sections 6 and 7).

(6) The junction-to-board characterization parameter, ψ_{JB}, estimates the junction temperature of a device in a real system and is extracted from the simulation data for obtaining θ_{JA}, using a procedure described in JESD51-2a (sections 6 and 7).

(7) The junction-to-case (bottom) thermal resistance is obtained by simulating a cold plate test on the exposed (power) pad. No specific JEDEC standard test exists, but a close description can be found in the ANSI SEMI standard G30-88.

RECOMMENDED OPERATING CONDITIONS

over operating free-air temperature range (unless otherwise noted)

		MIN	NOM	MAX	UNIT
V _{IN}	Input voltage	4.5		60	V

ELECTRICAL CHARACTERISTICS

 Unless otherwise stated, these specifications apply for $-40^{\circ}\text{C} \leq T_J \leq 125^{\circ}\text{C}$, $V_{\text{VIN}}=12\text{ V}$

PARAMETER		TEST CONDITIONS	MIN	TYP	MAX	UNIT
INPUT SUPPLY						
V_{VIN}	Input voltage range		4.5		60	V
I_{SD}	Shutdown current	$V_{\text{ENABLE}} < 100\text{ mV}$		1	2.5	μA
I_{QQ}	Operating current, drivers not switching	$V_{\text{ENABLE}} \geq 2\text{ V}$, $f_{\text{SW}} = 300\text{ kHz}$			4.5	mA
ENABLE						
V_{DIS}	ENABLE pin voltage to disable the device				100	mV
V_{EN}	ENABLE pin voltage to enable the device		600			mV
I_{ENABLE}	ENABLE pin source current				300	nA
8-V AND 3.3-V REGULATORS						
V_{VBP}	8-V regulator output voltage	$V_{\text{ENABLE}} \geq 2\text{ V}$, $8.2\text{ V} < V_{\text{VIN}} \leq 60\text{ V}$, $0\text{ mA} < I_{\text{IN}} < 20\text{ mA}$	7.8	8.0	8.3	V
V_{DO}	8-V regulator dropout voltage, $V_{\text{VIN-VVBP}}$	$4.5 < V_{\text{VIN}} \leq 8.2\text{ V}$, $V_{\text{EN}} \geq 2.0\text{ V}$, $I_{\text{IN}} = 10\text{ mA}$		110	200	mV
V_{VDD}	3.3-V regulator output voltage	$V_{\text{ENABLE}} \geq 2\text{ V}$, $4.5\text{ V} < V_{\text{VIN}} \leq 60\text{ V}$, $0\text{ mA} < I_{\text{IN}} < 5\text{ mA}$	3.22	3.30	3.42	V
FIXED AND PROGRAMMABLE UVLO						
V_{UVLO}	Programmable UVLO ON voltage (at UVLO pin)	$V_{\text{ENABLE}} \geq 2\text{ V}$	878	900	919	mV
I_{UVLO}	Hysteresis current out of UVLO pin	$V_{\text{ENABLE}} \geq 2\text{ V}$, UVLO pin $> V_{\text{UVLO}}$	4.06	5.00	6.20	μA
$V_{\text{BPO}}_{\text{ON}}$	VBP turn-on voltage	$V_{\text{ENABLE}} \geq 2\text{ V}$, UVLO pin $> V_{\text{UVLO}}$	3.85		4.40	V
$V_{\text{BPO}}_{\text{OFF}}$	VBP turn-off voltage		3.60		4.05	
$V_{\text{BPO}}_{\text{HYS}}$	VBP UVLO Hysteresis voltage		180		400	mV
REFERENCE						
V_{REF}	Reference voltage (+ input of the error amplifier)	$T_J = 25^{\circ}\text{C}$, $4.5\text{ V} < V_{\text{VIN}} \leq 60\text{ V}$ $-40^{\circ}\text{C} \leq T_J \leq 125^{\circ}\text{C}$, $4.5\text{ V} < V_{\text{VIN}} \leq 60\text{ V}$	594	600	606	mV
			591	600	609	
OSCILLATOR						
f_{SW}	Switching frequency	Range (typical)	100		600	kHz
		$R_{\text{RT}} = 100\text{ k}\Omega$, $4.5\text{ V} < V_{\text{VIN}} \leq 60\text{ V}$	90	100	110	
		$R_{\text{RT}} = 31.6\text{ k}\Omega$, $4.5\text{ V} < V_{\text{VIN}} \leq 60\text{ V}$	270	300	330	
		$R_{\text{RT}} = 14.3\text{ k}\Omega$, $4.5\text{ V} < V_{\text{VIN}} \leq 60\text{ V}$	540	600	660	
V_{VALLEY}	Valley voltage		0.7	1	1.2	V
$K_{\text{PWM}}^{(1)}$	PWM Gain ($V_{\text{VIN}} / V_{\text{RAMP}}$)	$4.5\text{ V} < V_{\text{VIN}} \leq 60\text{ V}$	14	15	16	V/V
PWM AND DUTY CYCLE						
$t_{\text{ON}}^{(1)}$	Minimum controlled pulse	$V_{\text{VIN}} = 4.5\text{ V}$, $f_{\text{SW}} = 300\text{ kHz}$		100	150	ns
		$V_{\text{VIN}} = 12\text{ V}$, $f_{\text{SW}} = 300\text{ kHz}$		75	100	
		$V_{\text{VIN}} = 60\text{ V}$, $f_{\text{SW}} = 300\text{ kHz}$		50	80	
$t_{\text{OFF}}^{(1)}$	Minimum OFF time	$V_{\text{VIN}} = 12\text{ V}$, $f_{\text{SW}} = 300\text{ kHz}$		170	250	ns
$D_{\text{MAX}}^{(1)}$	Maximum duty cycle	$f_{\text{SW}} = 100\text{ kHz}$, $4.5\text{ V} < V_{\text{VIN}} \leq 60\text{ V}$	95%			
		$f_{\text{SW}} = 300\text{ kHz}$, $4.5\text{ V} < V_{\text{VIN}} \leq 60\text{ V}$	91%			
		$f_{\text{SW}} = 600\text{ kHz}$, $4.5\text{ V} < V_{\text{VIN}} \leq 60\text{ V}$	82%			

(1) Ensured by design, not production tested.

ELECTRICAL CHARACTERISTICS (continued)

Unless otherwise stated, these specifications apply for $-40^{\circ}\text{C} \leq T_J \leq 125^{\circ}\text{C}$, $V_{\text{VIN}}=12\text{ V}$

PARAMETER		TEST CONDITIONS	MIN	TYP	MAX	UNIT
ERROR AMPLIFIER						
GBWP ⁽²⁾	Gain bandwidth product		7	10	13	MHz
A _{OL} ⁽²⁾	Open-loop gain		80	90	95	dB
I _{IB}	Input bias current				100	nA
I _{EAOP}	Output source current	V _{VFB} = 0 V	2			mA
I _{EAOM}	Output sink current	V _{VFB} = 1 V	2			mA
PROGRAMMABLE SOFT START						
I _{SS(source,start)}	Soft-start source current at V _{SS} < 0.5 V	V _{SS} = 0.25 V	42	52	62	μA
I _{SS(source,normal)}	Soft-start source current at V _{SS} > 0.5 V	V _{SS} = 1.5 V	9.3	11.6	13.9	μA
I _{SS(sink)}	Soft-start sink current	V _{SS} = 1.5 V	0.77	1.05	1.33	μA
V _{SS(fttH)}	SS pin HIGH voltage during fault (OC or thermal) reset timing		2.38	2.50	2.61	V
V _{SS(fttL)}	SS pin LOW voltage during fault (OC or thermal) reset timing		235	300	375	mV
V _{SS(steady_state)}	SS pin voltage during steady-state		3.25	3.30	3.50	V
V _{SS(offst)}	Initial offset voltage from SS pin to error amplifier input		525	650	775	mV
TRACKING						
V _{TRK(ctrl)} ⁽²⁾	Range of TRK which overrides V _{REF}	4.5 V < V _{IN} ≤ 60 V	0		600	mV
SYNCHRONIZATION (MASTER/SLAVE)						
V _{MSTR}	M/S pin voltage in master mode		3.9		V _{IN}	V
V _{SLV(0)}	M/S pin voltage in slave 0 deg mode		1.25		1.75	V
V _{SLV(180)}	M/S pin voltage in slave 180 deg mode		0		0.75	V
I _{SYNC(in)}	SYNC pin pull-down current	M/S configured as slave- 0 degrees or slave-180 degrees	8	11	14	μA
V _{SYNC(in_high)}	SYNC pin input high-voltage level		2			V
V _{SYNC(in_low)}	SYNC pin input low-voltage level				0.8	V
t _{SYNC(high_min)}	Minimum SYNC high pulse-width		40	50		ns
t _{SYNC(low_min)}	Minimum SYNC low pulse-width		40	50		ns
GATE DRIVERS						
R _{HDHI}	High-side driver pull-up resistance	C _{LOAD} = 2.2 nF, I _{DRV} = 300 mA	1.37	2.64	3.50	Ω
R _{HDLO}	High-side driver pull-down resistance		1.08	2.40	3.35	Ω
R _{LDHI}	Low-side driver pull-up resistance		1.37	2.40	3.20	Ω
R _{LDLO}	Low-side driver pull-down resistance		0.44	1.10	1.70	Ω
t _{NON-OVERLAP1}	Time delay between HDRV fall and LDRV rise	C _{LOAD} = 2.2 nF, V _{HDRV} = 2 V, V _{LDRV} = 2 V		50		ns
t _{NON-OVERLAP2}	Time delay between HDRV rise and LDRV fall			60		
OVERCURRENT PROTECTION (LOW-SIDE MOSFET SENSING)						
I _{ILIM}	ILIM pin source current	4.5 V < V _{IN} < 60 V, T _J = 25°C	9.00	9.75	10.45	μA
I _{ILIM(ss)}	ILIM pin source current during Soft-start			15		
I _{ILIM, Tc} ⁽²⁾	Temperature coefficient of ILIM current	4.5 V < V _{IN} < 60 V		1400		ppm
V _{ILIM} ⁽²⁾	ILIM pin voltage operating range	4.5 V < V _{IN} < 60 V	50		300	mV
OCP _{TH}	Overcurrent protection threshold (Voltage across low-side FET for detecting overcurrent)	R _{ILIM} = 10 kΩ, I _{ILIM} = 10 μA (V _{ILIM} = 100 mV)	-110	-100	-84	mV
SHORT CIRCUIT PROTECTION HIGH-SIDE MOSFET SENSING)						
V _{LDRV(max)}	LDRV pin maximum voltage during calibration	R _{LDRV} = open		300	360	mV
A _{OC3}	Multiplier factor to set the SCP based on OCP level setting at the ILIM pin	R _{LDRV} = 10 kΩ	2.75	3.20	3.60	V/V
A _{OC7}		R _{LDRV} = open	6.40	7.25	7.91	V/V
A _{OC15}		R _{LDRV} = 20 kΩ	13.9	16.4	18.0	V/V

(2) Ensured by design, not production tested.

TPS40170

SLUS970 – MARCH 2011

www.ti.com

ELECTRICAL CHARACTERISTICS (continued)

 Unless otherwise stated, these specifications apply for $-40^{\circ}\text{C} \leq T_J \leq 125^{\circ}\text{C}$, $V_{VIN}=12\text{ V}$

PARAMETER		TEST CONDITIONS	MIN	TYP	MAX	UNIT
THERMAL SHUTDOWN						
$T_{SD, \text{set}}^{(3)}$	Thermal shutdown set threshold	$4.5\text{ V} < V_{VIN} < 60\text{ V}$	155	165	175	$^{\circ}\text{C}$
$T_{SD, \text{reset}}^{(3)}$	Thermal shutdown reset threshold		125	135	145	$^{\circ}\text{C}$
$T_{\text{hyst}}^{(3)}$	Thermal shutdown hysteresis		30			$^{\circ}\text{C}$
POWER GOOD						
V_{OV}	FB pin voltage upper limit for power good	$4.5\text{ V} < V_{VIN} < 60\text{ V}$	627	647	670	mV
V_{UV}	FB pin voltage lower limit for power good		527	552	570	
$V_{PG, \text{HYST}}$	Power good hysteresis voltage at FB pin		8.5	20.0	32.0	
$V_{PG(\text{out})}$	PGOOD pin voltage when FB pin voltage $> V_{OV}$ or $< V_{UV}$, $I_{PGD}=2\text{ mA}$			100	mV	
$V_{PG(\text{np})}$	PGOOD pin voltage when device power is removed	V_{VIN} is open, $10\text{-k}\Omega$ to $V_{EXT} = 5\text{ V}$		1	1.5	V
BOOT DIODE						
V_{DFWD}	Bootstrap diode forward voltage	$I = 20\text{ mA}$	0.5	0.7	0.9	V
$R_{\text{BOOT-SW}}$	Discharge resistor from BOOT to SW			1		M Ω

(3) Ensured by design, not production tested.

DEVICE INFORMATION

RGY PACKAGE QFN-20 (Top View)

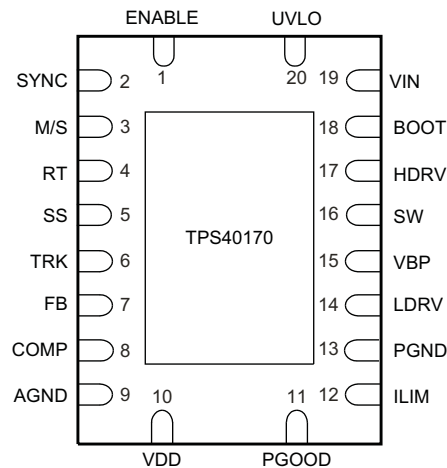

PIN FUNCTIONS

PIN		I/O	DESCRIPTION
NAME	NO.		
AGND	9	—	Analog signal ground. This pin must be electrically connected to power ground PGND externally.
BOOT	18	O	Boot capacitor node for high-side FET gate driver. The boot capacitor is connected from this pin to SW.
COMP	8	O	Output of the internal error amplifier. The feedback loop compensation network is connected from this pin to the FB pin.
ENABLE	1	I	This pin must be high for the device to be enabled. If this pin is pulled low, the device is put in a low-power consumption shutdown mode.
FB	7	I	Negative input to the error amplifier. The output voltage is fed back to this pin through a resistor divider network.
HDRV	17	O	Gate driver output for the high-side FET.
ILIM	12	I	A resistor from this pin to PGND sets the overcurrent limit. This pin provides source current used for overcurrent protection threshold setting.
LDRV	14	O	Gate driver output for the low-side FET. Also, a resistor from this pin to PGND sets the multiplier factor to determine short-circuit current limit. If no resistor is present the multiplier defaults to 7 times the ILIM pin voltage.
M/S	3	I	Master or slave mode selector pin for frequency synchronization. This pin must be tied to VIN for master mode. In the slave mode this pin must be tied to AGND or left floating. If the pin is tied to AGND, the device synchronizes with a 180° phase shift. If the pin is left floating, the device synchronizes with a 0° phase shift.
PGND	13	—	Power ground. This pin must externally connect to the AGND at a single point.
PGOOD	11	O	Power good indicator. This pin is an open-drain output pin and a 10-kΩ pull-up resistor is recommended to be connected between this pin and VDD.
RT	4	I	A resistor from this pin to AGND sets the oscillator frequency. Even if operating in slave mode, it is required to have a resistor at this pin to set the free running switching frequency.
SS	5	I	Soft-start. A capacitor must be connected at this pin to AGND. The capacitor value sets the soft-start time.
SW	16	I	This pin must connect to the switching node of the synchronous buck converter. The high-side and low-side FET current sensing are also done from this node.
SYNC	2	I/O	Synchronization. This is a bi-directional pin used for frequency synchronization. In the master mode, it is the SYNC output pin. In the slave mode, it is a SYNC input pin. If unused, this pin can be left open.
TRK	6	I	Tracking. External signal at this pin is used for output voltage tracking. This pin goes directly to the internal error amplifier as a positive reference. The lesser of the voltages between V _{TRK} and the internal 600-mV reference sets the output voltage. If not used, this pin should be pulled up to VDD.
UVLO	20	I	Undervoltage lockout. A resistor divider on this pin from VIN to AGND can be used to set the UVLO threshold.

PIN FUNCTIONS (continued)

PIN		I/O	DESCRIPTION
NAME	NO.		
VBP	15	O	8-V regulated output for gate driver. A ceramic capacitor with a value between 1 μ F and 10 μ F must be connected from this pin to PGND
VDD	10	O	3.3-V regulated output. A ceramic by-pass capacitor with a value between 0.1 μ F and 1 μ F must be connected between this pin and the AGND pin and placed closely to this pin.
VIN	19	I	Input voltage for the controller which is also the input voltage for the DC/DC converter. A 1- μ F by-pass capacitor from this pin to AGND must be added and placed closed to VIN.

DEVICE BLOCK DIAGRAM

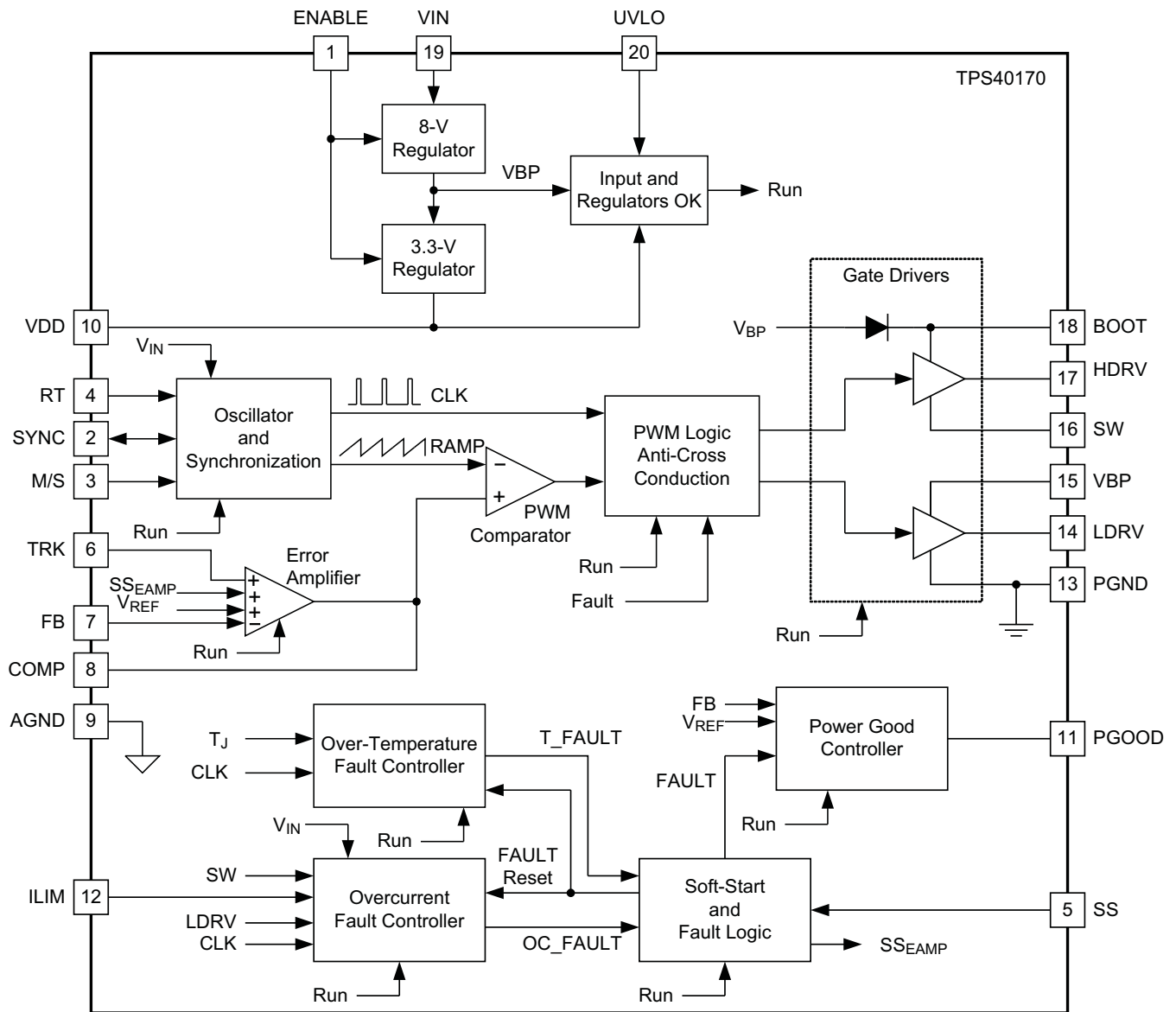

UDG-09218

TYPICAL CHARACTERISTICS

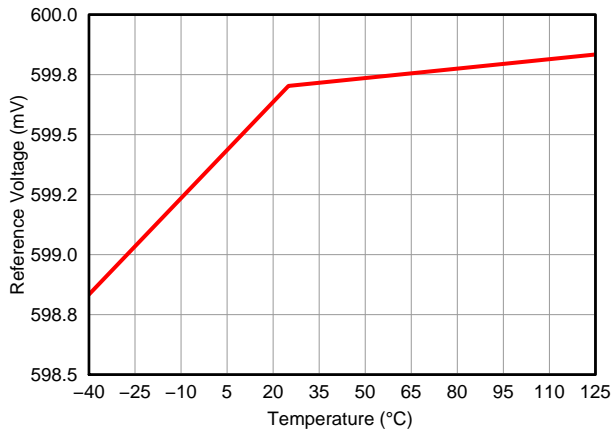

Figure 1. Reference Voltage vs. Junction Temperature

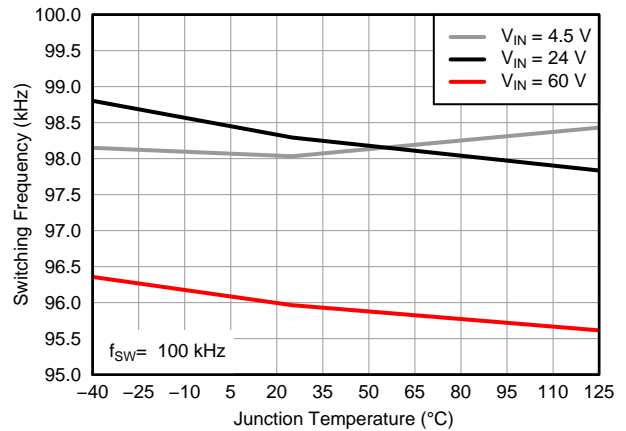

Figure 2. Switching Frequency vs. Junction Temperature (f_{sw} = 100 kHz)

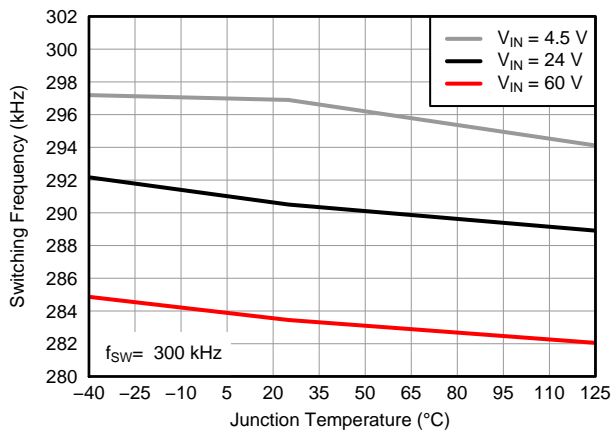

Figure 3. Switching Frequency vs. Junction Temperature (f_{sw} = 300 kHz)

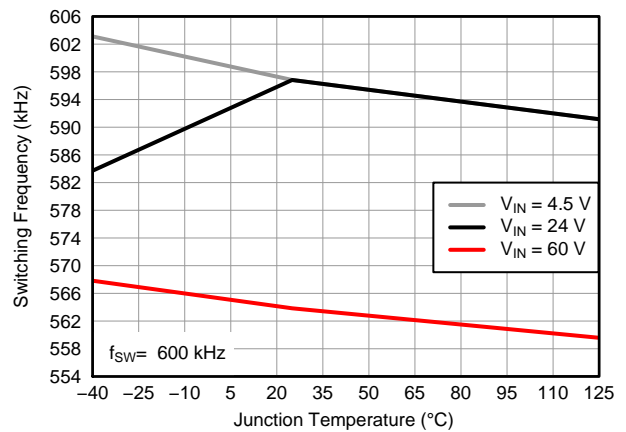

Figure 4. Switching Frequency vs. Junction Temperature (f_{sw} = 600 kHz)

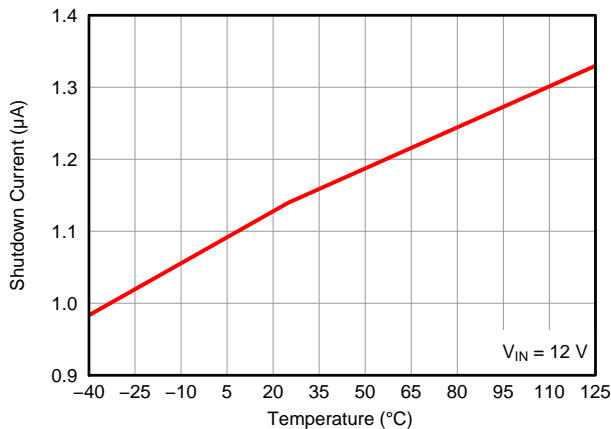

Figure 5. Shutdown Current vs. Junction Temperature

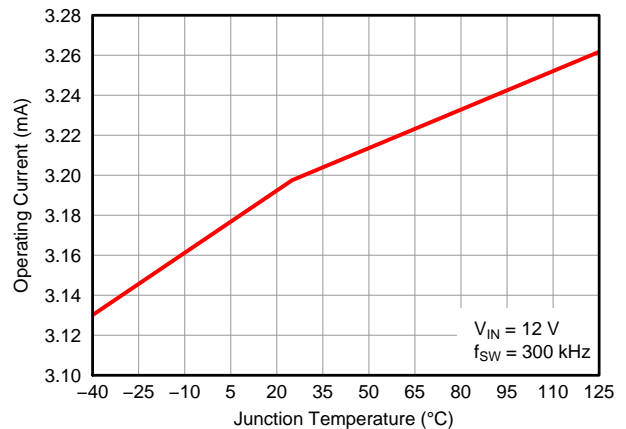

Figure 6. Operating Current vs. Junction Temperature

TYPICAL CHARACTERISTICS (continued)

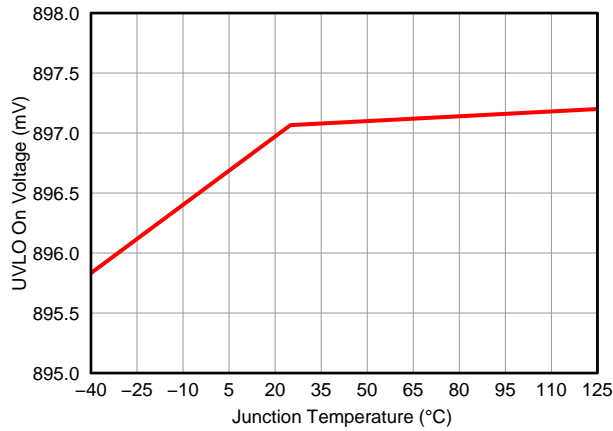

Figure 7. UVLO On Voltage vs. Junction Temperature

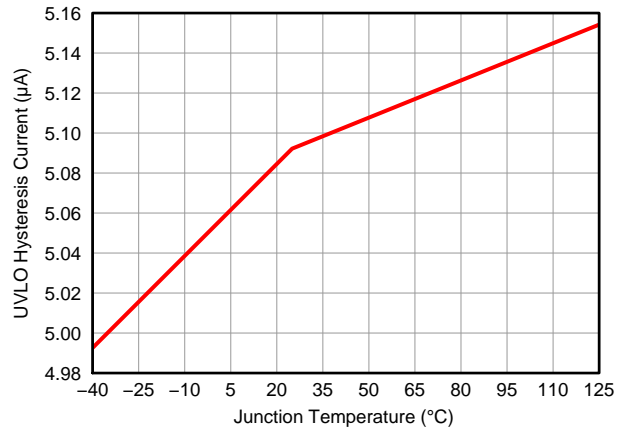

Figure 8. UVLO Hysteresis Current vs. Junction Temperature

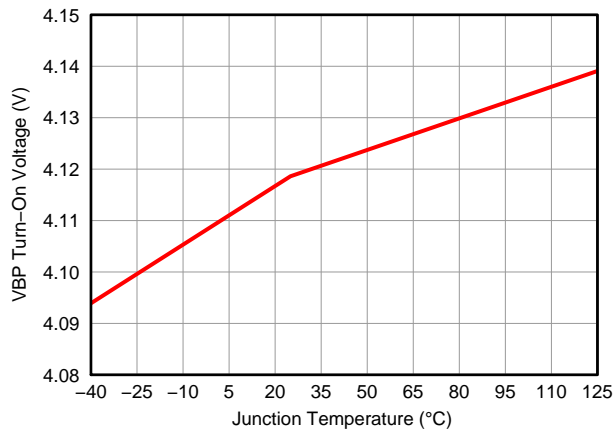

Figure 9. VBP Turn-On Voltage vs. Junction Temperature

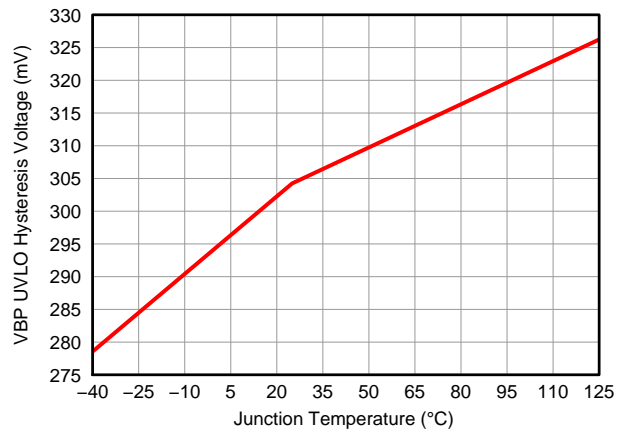

Figure 10. VBP UVLO Hysteresis Voltage

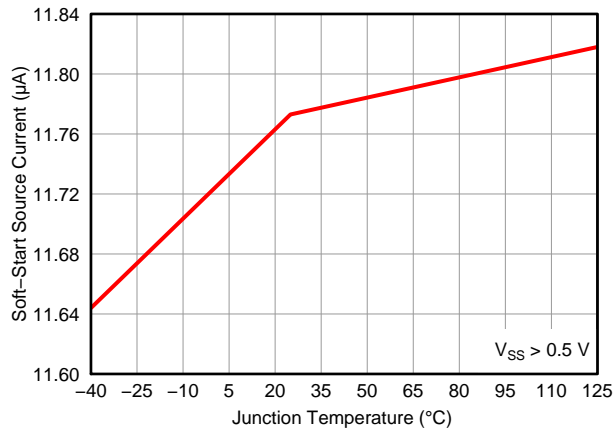

Figure 11. Soft-Start Source Current vs. Junction Temperature ($V_{SS} > 0.5$ V)

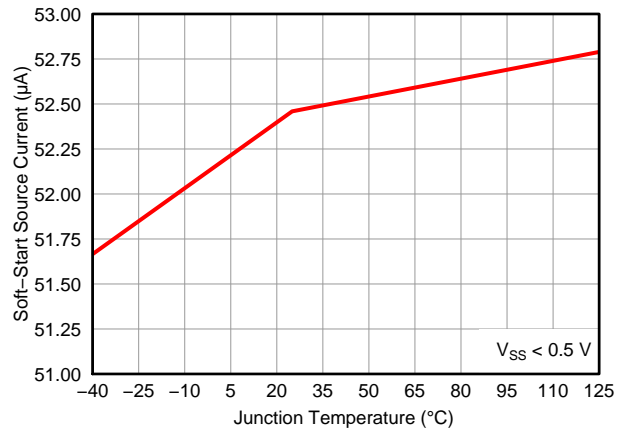

Figure 12. Soft-Start Source Current vs. Junction Temperature ($V_{SS} < 0.5$ V)

TYPICAL CHARACTERISTICS (continued)

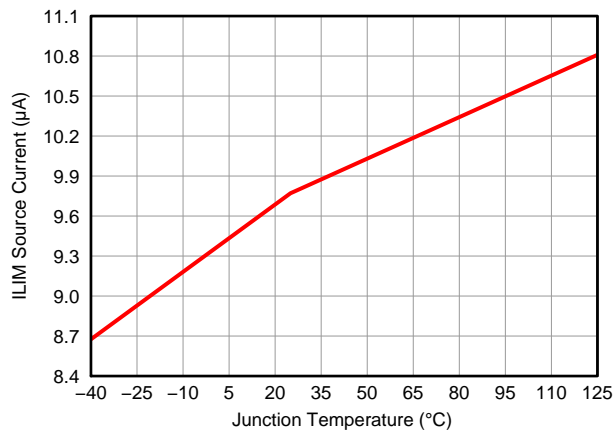

Figure 13. ILIM Source Current vs. Junction Temperature

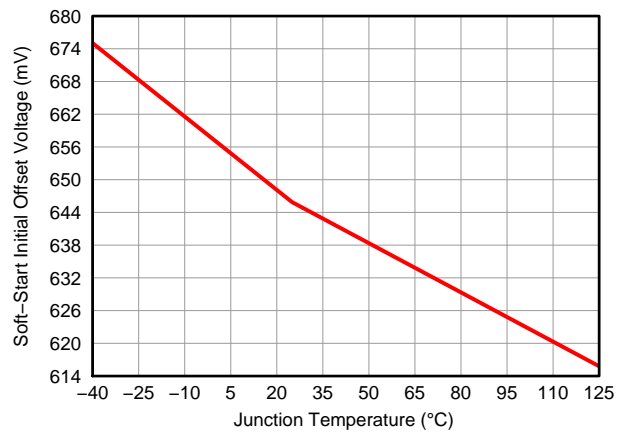

Figure 14. Soft-Start Initial Offset Voltage vs. Junction Temperature

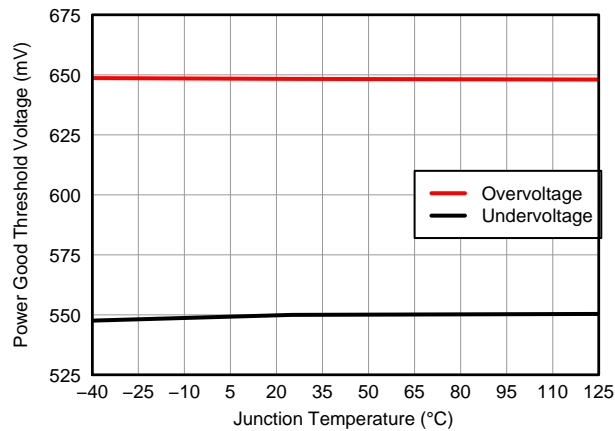

Figure 15. V_{OV}/V_{UV} Power Good Threshold Voltage

APPLICATION INFORMATION

FUNCTIONAL DESCRIPTION

The TPS40170 is a synchronous PWM buck controller that accepts a wide range of input voltage from 4.5 V to 60 V and features voltage-mode control with input-voltage, feed-forward compensation. The switching frequency is programmable from 100 kHz to 600 kHz.

The TPS40170 has a complete set of system protections such as programmable UVLO, programmable overcurrent protection (OCP), selectable short-circuit protection (SCP) and thermal shutdown. The ENABLE pin allows for system shutdown in a low-current (1- μ A typical) mode. The controller supports pre-biased outputs, provides an open-drain PGOOD signal, and has closed loop programmable soft-start, output voltage tracking and adaptive dead time control.

The TPS40170 provides accurate output voltage regulation via 1% specified accuracy.

Additionally, the controller implements a novel scheme of bidirectional synchronization with one controller acting as the master other downstream controllers acting as slaves, synchronized to the master in-phase or 180° out-of-phase. Slave controllers can be synchronized to an external clock within $\pm 30\%$ of the internal switching frequency.

LDO Linear Regulators and Enable

The TPS40170 has two internal low-drop-out (LDO) linear regulators. One has a nominal output voltage of V_{VBP} and is present at the VBP pin. This is the voltage that is mainly used for the gate-driver output. The other linear regulator has an output voltage of V_{VDD} and is present at the VDD pin. This voltage can be used in external low-current logic circuitry. The maximum allowable current drawn from the VDD pin must not exceed 5 mA.

The TPS40170 has a dedicated device enable pin (ENABLE). This simplifies user level interface design because no multiplexed functions exist. If the ENABLE pin of the TPS40170 is higher than V_{EN} , then the LDO regulators are enabled. To ensure that the LDO regulators are disabled, the ENABLE pin must be pulled below V_{DIS} . By pulling the ENABLE pin below V_{DIS} , the device is completely disabled and the current consumption is very low (nominally, 1 μ A). Both LDO regulators are actively discharged when the ENABLE pin is pulled below V_{DIS} . A functionally equivalent circuit to the enable circuitry on the TPS40170 is shown in [Figure 16](#).

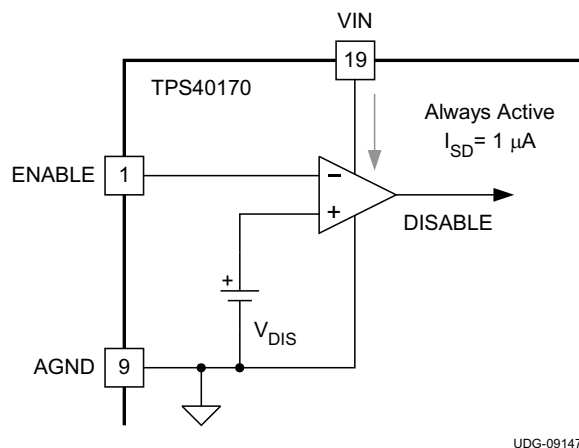

Figure 16. TPS40170 ENABLE Functional Block

The ENABLE pin must not be allowed to float. If the ENABLE function is not needed for the design, then it is suggested that the ENABLE pin be pulled up to V_{IN} by a high value resistor ensuring that the current into the ENABLE pin does not exceed 10 μ A. If it is not possible to meet this clamp current requirement, then it is suggested that a resistor divider from V_{IN} to GND be used to connect to ENABLE pin. The resistor divider should be such that the ENABLE pin should be higher than V_{EN} and lower than 8 V.

NOTE

To avoid potential erroneous behavior of the enable function, the ENABLE signal applied must have a minimum slew rate of 20 V/s.

Input Undervoltage Lockout (UVLO)

The TPS40170 has both fixed and programmable input undervoltage lockout (UVLO). In order for the device to turn ON, all of the following conditions must be met:

- The ENABLE pin voltage must be greater than V_{EN}
- The VBP voltage (at VBP pin) must be greater than $V_{VBP(on)}$
- The UVLO pin must be greater than V_{UVLO}

In order for the device to turn OFF, any one of the following conditions must be met:

- The ENABLE pin voltage must be less than V_{DIS}
- The VBP voltage (at VBP pin) must be less than $V_{VBP(off)}$
- The UVLO pin must be less than V_{UVLO}

Programming the input UVLO can be accomplished using the UVLO pin. A resistor divider from the input voltage (V_{IN} pin) to GND sets the UVLO level. Once the input voltage reaches a value that meets the V_{UVLO} level at the UVLO pin, then a small hysteresis current, I_{UVLO} at the UVLO pin is switched in. The programmable UVLO function is shown in Figure 17.

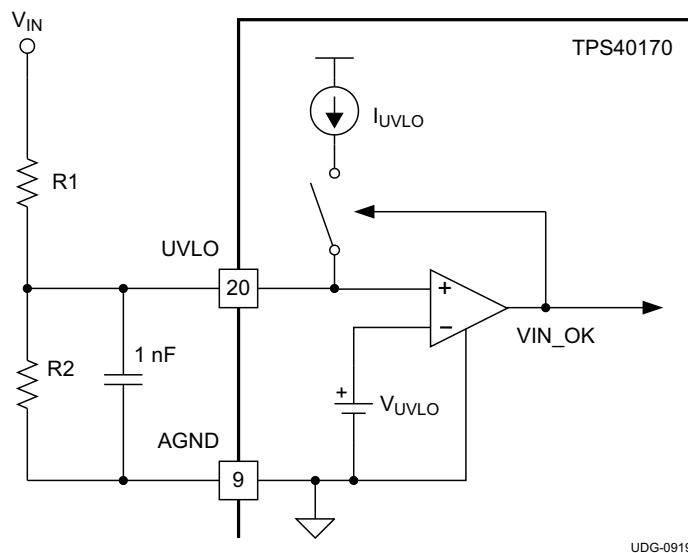

Figure 17. UVLO Functional Block Schematic

Equations for Programming the Input UVLO:

Components R1 and R2 represent external resistors for programming UVLO and hysteresis and can be calculated in [Equation 1](#) and [Equation 2](#) respectively.

$$R_1 = \frac{V_{ON} - V_{OFF}}{I_{UVLO}} \quad (1)$$

$$R_2 = R_1 \times \frac{V_{UVLO}}{(V_{ON} - V_{UVLO})}$$

where

- V_{ON} is the desired turn-on voltage of the converter
- V_{OFF} is the desired turn-off voltage for the converter
- I_{UVLO} is the hysteresis current generated by the device, 5.0 μ A (typ)
- V_{UVLO} is the UVLO pin threshold voltage, 0.9 V (typ)

NOTE

If the UVLO pin is connected to a voltage greater than 0.9 V, the programmable UVLO is disabled and the device defaults to an internal UVLO ($V_{VBP(on)}$ and $V_{VBP(off)}$). For example, the UVLO pin can be connected to VDD or the VBP pin to disable the programmable UVLO function.

A 1-nF ceramic by-pass capacitor must be connected between the UVLO pin and GND.

Oscillator and Voltage Feed-Forward

TPS40170 implements an oscillator with input-voltage feed-forward compensation that enables instant response to input voltage changes. [Figure 18](#) shows the oscillator timing diagram for the TPS40170. The resistor from the RT pin to GND sets the free running oscillator frequency. The voltage V_{RT} on the RT pin is made proportional to the input voltage (see [Equation 3](#)).

$$V_{RT} = \frac{V_{IN}}{K}$$

where

- $K = 15$

The resistor at the RT pin sets the current in the RT pin. The proportional current charges an internal 100-pF oscillator capacitor. The ramp voltage on this capacitor is compared with the RT pin voltage, V_{RT} . Once the ramp voltage reaches V_{RT} , the oscillator capacitor is discharged. The ramp that is generated by the oscillator (which is proportional to the input voltage) acts as voltage feed-forward ramp to be used in the PWM comparator.

The time between the start of the discharging oscillator capacitor and the start of the next charging cycle is fixed at 170 ns (typical). During the fixed discharge time, the PWM output is maintained as OFF. This is the minimum OFF-time of the PWM output.

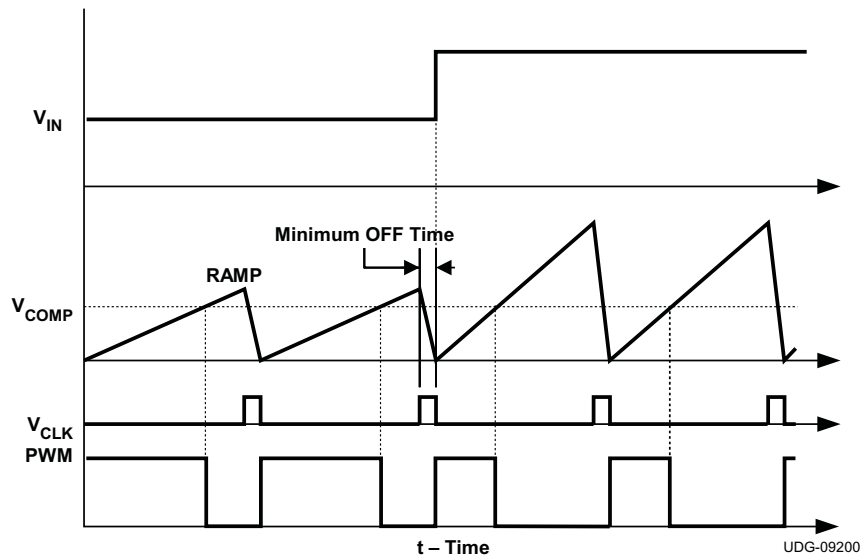

Figure 18. Feed-Forward Oscillator Timing Diagram

Calculating the Timing Resistance (R_{RT})

$$R_{RT} = \left(\frac{10^4}{f_{SW}} \right) - 2 \text{ (k}\Omega\text{)}$$

where

- f_{SW} is the switching frequency in kHz
- R_{RT} is the resistor connected from RT pin to GND in k Ω

(4)

NOTE

The switching frequency can be adjusted between 100 kHz and 600 kHz. The maximum switching frequency before skipping pulses is determined by the input voltage, output voltage, FET resistances, DCR of the inductor, and the minimum on time of the TPS40170. Use [Equation 5](#) to determine the maximum switching frequency. For further details, please see application note [SLYT293](#).

$$f_{SW(max)} = \frac{V_{OUT(min)} + (I_{OUT(min)} \times (R_{DS2} + R_{LOAD}))}{t_{ON(min)} \times (V_{IN(max)} - I_{OUT(min)} \times (R_{DS1} - R_{DS2}))}$$

where

- $f_{SW(max)}$ is the maximum switching frequency
- $V_{OUT(min)}$ is the minimum output voltage
- $V_{IN(max)}$ is the maximum input voltage
- $I_{OUT(min)}$ is the minimum output current
- R_{DS1} is the high-side FET resistance
- R_{DS2} is the low-side FET resistance
- and R_{LOAD} is the inductor series resistance

(5)

Overcurrent Protection and Short-Circuit Protection (OCP and SCP)

The TPS40170 has the capability to set a two-level overcurrent protection. The first level of overcurrent protection (OCP) is the normal overload setting based on low-side MOSFET voltage sensing. The second level of protection is the heavy overload setting such as short-circuit based on the high-side MOSFET voltage sensing. This protection takes effect immediately. The second level is termed short-circuit protection (SCP).

The OCP level is set by the ILIM pin voltage. A current (I_{ILIM}) is sourced into the ILIM pin from which a resistor R_{ILIM} is connected to GND. Resistor R_{ILIM} sets the first level of overcurrent limit. The OCP is based on the low-side FET voltage at the switch-node (SW pin) when the LDRV is ON after a blanking time, which is the product of inductor current and low-side FET turn-on resistance $R_{DS(on)}$. The voltage is inverted and compared to ILIM pin voltage. If it is greater than the ILIM pin voltage, then a 3-bit counter inside the device increments the fault-count by 1 at the start of the next switching cycle. Alternatively, if it is less than the ILIM pin voltage, then the counter inside the device decrements the fault-count by 1. When the fault-count reaches 7, an overcurrent fault (OC_FAULT) is declared and both the HDRV and LDRV are turned OFF. The resistor R_{ILIM} can be calculated by the following Equation 6.

$$R_{ILIM} = \frac{I_{OC} \times R_{DS(on)}}{I_{ILIM}} = \frac{I_{OC} \times R_{DS(on)}}{9.0\mu A} \tag{6}$$

The SCP level is set by a multiple of the ILIM pin voltage. The multiplier has three discrete values, 3, 7 or 15 times, which can be selected by respectively choosing a 10-kΩ, open circuit, or 20-kΩ resistor from LDRV pin to GND. This multiplier AOC information is translated during the t_{CAL} time, which starts after the enable and UVLO conditions are met.

The SCP is based on sensing the high-side FET voltage drop from V_{VIN} to V_{SW} when the HDRV is ON after a blanking time, which is product of inductor current and high-side FET turn-on resistance $R_{DS(on)}$. The voltage is compared to the product of multiplier and the ILIM pin voltage. If it exceeds the product, then the fault-count is immediately set to 7 and the OC_FAULT is declared. The HDRV is terminated immediately without waiting for the duty cycle to end. When an OC_FAULT is declared, both the HDRV and LDRV are turned OFF. The appropriate multiplier (A), can be selected using Equation 7.

$$A = \frac{I_{SC} \times R_{DS(on)HS}}{I_{OC} \times R_{DS(on)LS}} \tag{7}$$

Figure 19 shows the functional block of the two-level overcurrent protection.

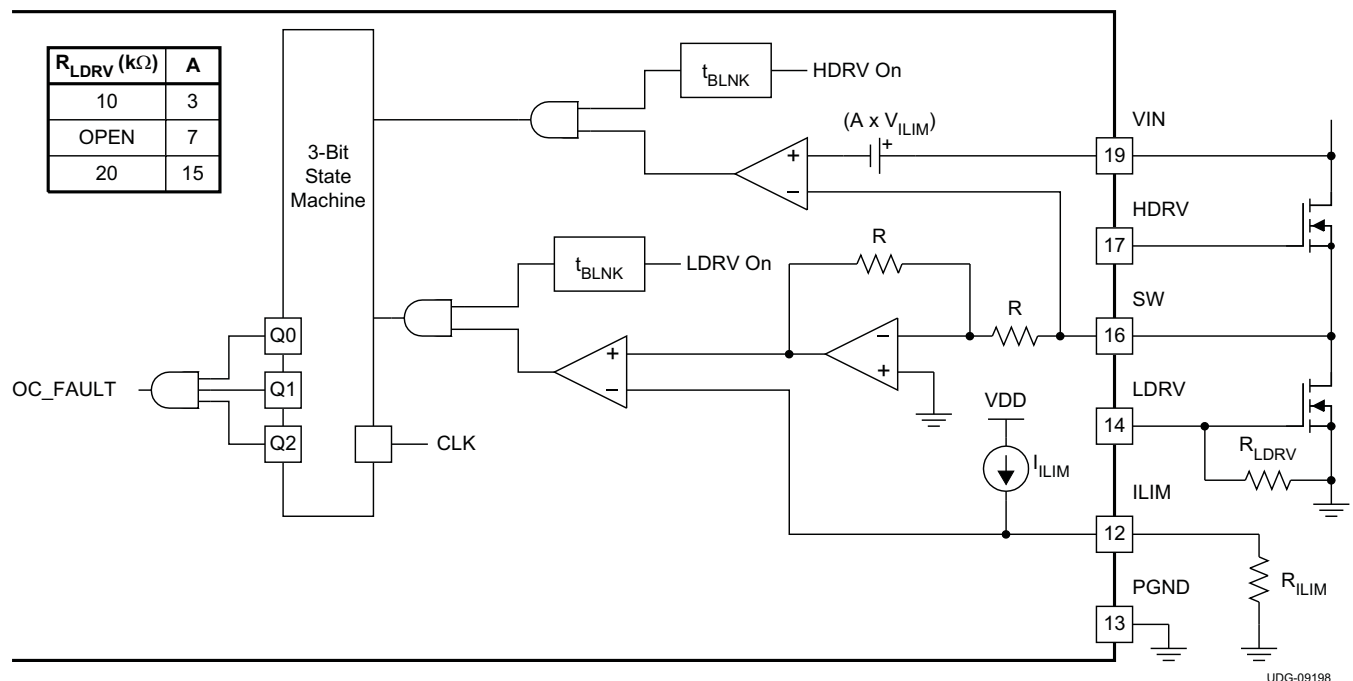

Figure 19. OCP and SCP Protection Functional Block Diagram

NOTE

Both OCP and SCP are based on low-side and high-side MOSFET voltage sensing at the SW node. Excessive ringing on the SW node can have negative impact on the accuracy of OCP and SCP. Adding an R-C snubber from the SW node to GND helps minimize the potential impact.

Soft-Start and Fault-Logic

A capacitor from the SS pin to GND defines the SS time, t_{SS} . The TPS40170 enters into soft-start immediately after completion of the overcurrent calibration. The SS pin goes through the device's internal level-shifter circuit before reaching one of the positive inputs of the error amplifier. The SS pin must reach approximately 0.65 V before the input to the error amplifier begins to rise above 0 V. To charge the SS pin from 0 V to 0.65 V faster, at the beginning of the soft-start in addition to the normal charging current, (11.6 μ A, typ.), an extra charging current (40.4 μ A, typ.) is switched-in to the SS pin. As the SS capacitor reaches 0.5 V, the extra charging current is turned off and only the normal charging current remains. Figure 20 shows the soft-start function block.

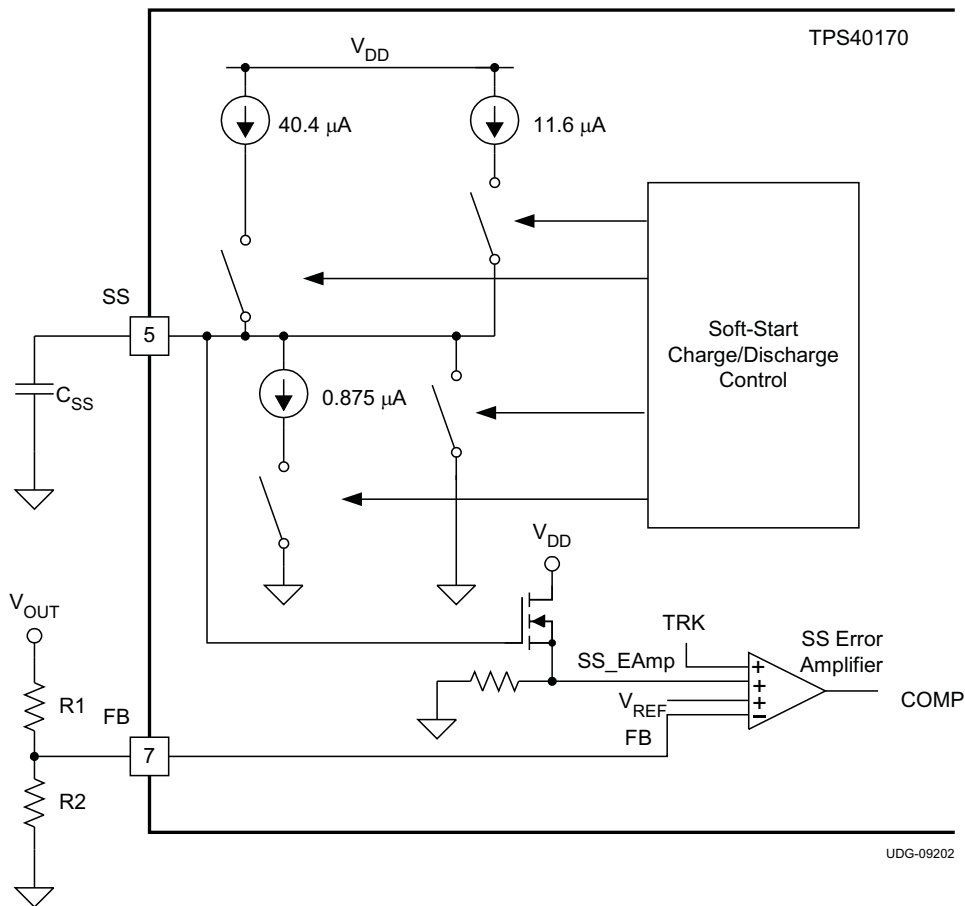

Figure 20. Soft-Start Schematic Block

As the SS pin voltage approaches 0.65 V, the positive input to the error amplifier begins to rise (see Figure 21). The output of the error amplifier (the COMP pin) starts rising. The rate of rise of the COMP voltage is mainly limited by the feedback loop compensation network. Once V_{COMP} reaches the valley of the PWM ramp, the switching begins. The output is regulated to the error amplifier input through the FB pin in the feedback loop. Once the FB pin reaches the 600-mV reference voltage, the feedback node is regulated to the reference voltage, V_{REF} . The SS pin continues to rise and is clamped to V_{DD} .

The SS pin is discharged through an internal switch during the following conditions:

- Input (VIN) undervoltage lock out UVLO pin less than V_{UVLO}
- Overcurrent protection calibration time (t_{CAL})
- VBP less than threshold voltage ($V_{BP(off)}$)

Because it is discharged through an internal switch, the discharging time is relatively fast compared with the discharging time during the fault restart which is discussed in the *Soft-start During Overcurrent Fault* section.

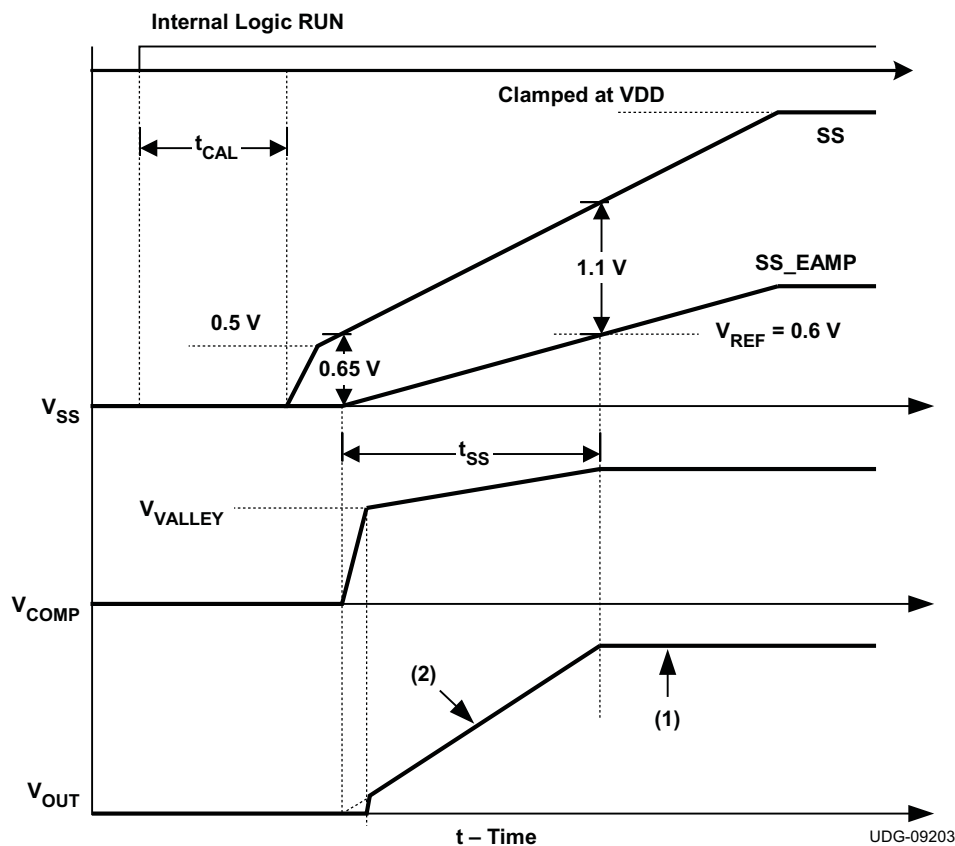

Figure 21. Soft-Start Waveforms

NOTE

Referring to [Figure 21](#)

- (1) V_{REF} dominates the positive input of the error amplifier
- (2) V_{SS_EAMP} dominates the positive input of the error amplifier

For $0 < V_{SS_EAMP} < V_{REF}$

$$V_{OUT} = V_{SS(EAMP)} \times \frac{(R1+R2)}{R2} \quad (8)$$

For $V_{SS_EAMP} > V_{REF}$

$$V_{OUT} = V_{REF} \times \frac{(R1+R2)}{R2} \quad (9)$$

Soft-Start During Overcurrent Fault

The soft-start block also has a role to controls the fault-logic timing. If an overcurrent fault (OC_FAULT) is declared, the soft-start capacitor is discharged internally through the device by a small current $I_{SS(sink)}$ (1.05 μ A, typ.). Once the SS pin capacitor is discharged to below $V_{SS(FLT,low)}$ (300 mV, typ.), the soft-start capacitor begins charging again. If the fault is persistent, a fault is declared which is determined by the overcurrent protection state machine. If the soft-start capacitor is below $V_{SS(FLT,high)}$ (2.5 V, typ.), then the soft-start capacitor continues to charge until it reaches $V_{SS(FLT,high)}$ before a discharge cycle is initiated. This ensures that the re-start time-interval is always constant. Figure 22 shows the re-start timing.

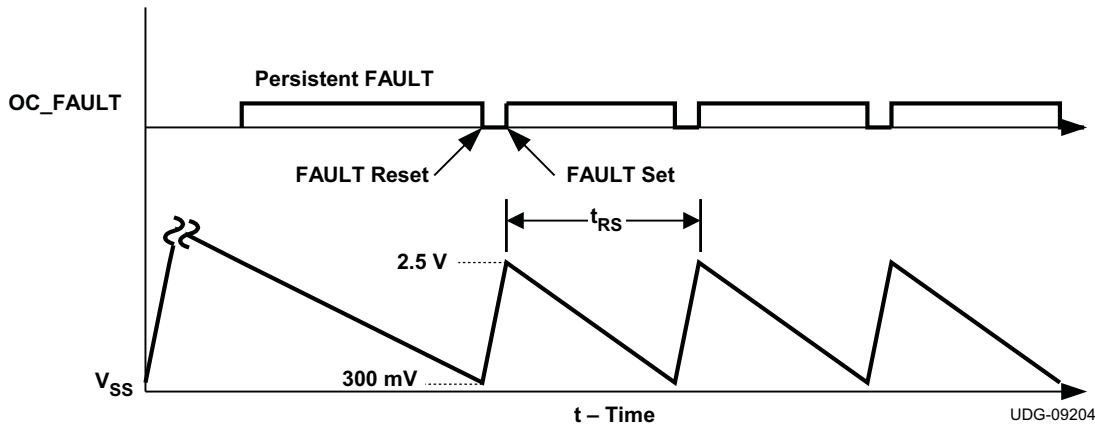

Figure 22. Overcurrent Fault Restart Timing

NOTE

For the feedback to be regulated to the SS_EAMP voltage, the TRK pin must be pulled up high directly or through a resistor to VDD.

Equations for Soft-Start and Restart Time

The soft-start time (t_{SS}) is defined as the time taken for the internal SS_EAMP node to go from 0 V to the 0.6 V V_{REF} voltage. The SS_EAMP starts rising as the SS pin goes beyond 0.65 V. The offset voltage between the SS and the SS_EAMP starts increasing as the SS pin voltage starts rising. Figure 21, shows that the SS time can be defined as the time taken for the SS pin voltage to change by 1.05 V (see Equation 10).

The restart time (t_{RS}) is defined in Equation 11 as the time taken for the soft-start capacitor (C_{SS}) to discharge from 2.5 V to 0.3 V and to then recharge up to 2.5 V.

$$C_{SS} = \frac{t_{SS}}{0.09} \quad (10)$$

$$t_{RS} \approx 2.28 \times C_{SS}$$

where

- C_{SS} is the soft-start capacitance in nF
- t_{SS} is the soft-start time in ms
- t_{RS} is the re-start time in ms

(11)

NOTE

During soft-start ($V_{SS} < 2.5$ V), the overcurrent protection limit is 1.5 times normal overcurrent protection limit. This allows higher output capacitance to fully charge without activating overcurrent protection.

Over-Temperature Fault

Figure 23 shows the over-temperature protection scheme. If the junction temperature of the device reaches the thermal shutdown limit of $t_{SD(set)}$ (165°C, typ) and SS charging is completed, an over-temperature FAULT is declared. The soft-start capacitor begins to be discharged. During soft-start discharging period, the PWM switching is terminated; therefore both HDRV and LDRV are driven low, turning off both MOSFETs.

The soft-start capacitor begins to charge and over-temperature fault is reset whenever the soft-start capacitor is discharged below $V_{SS(ft,low)}$ (300 mV, typ.). During each restart cycle, PWM switching is turned on. When SS is fully charged, PWM switching is terminated. These restarts repeat until the temperature of the device has fallen below the thermal reset level, $t_{SD(reset)}$ (135°C typ). PWM switching continues and system returns to normal regulation.

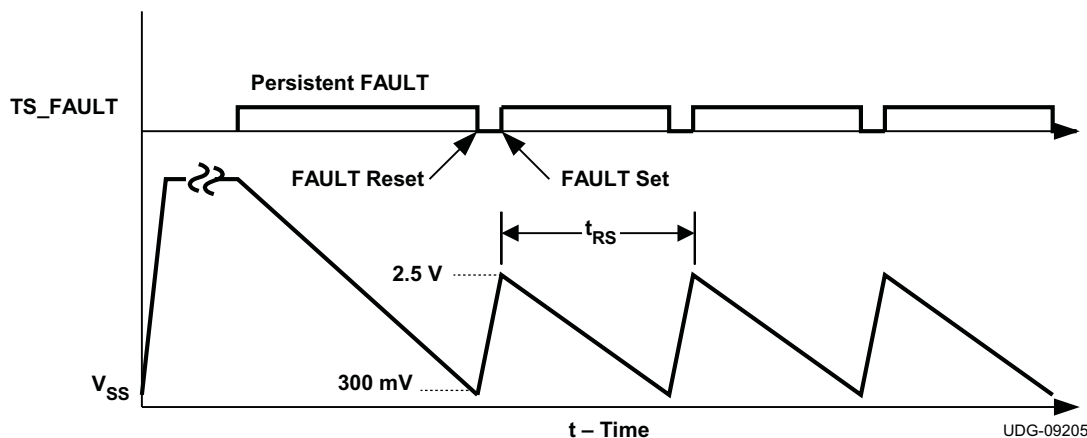

Figure 23. Over-Temperature Fault Restart Timing

The soft-start timing during over-temperature fault is the same as the soft-start timing during overcurrent fault. See the *Equations for Soft-Start and Re-Start Time* section.

Frequency Synchronization

The TPS40170 has three modes.

- **Master mode:** In this mode the master/slave selector pin, (M/S) is connected to VIN. The SYNC pin emits a stream of pulses at the same frequency as the PWM switching frequency. The pulse stream at the SYNC pin is of 50% duty cycle and the same amplitude as V_{VBP} . Also, the falling edge of the voltage on SYNC pin is synchronized with the rising edge of the HDRV.
- **Slave-180° mode:** In this mode the M/S pin is connected to GND. The SYNC pin of the TPS40170 accepts a synchronization clock signal, and the HDRV is synchronized with the rising edge of the incoming synchronization clock.
- **Slave-0° mode:** In this mode, the M/S pin is left open. The SYNC pin of the TPS40170 accepts a synchronization clock signal, and the HDRV is synchronized with the falling edge of the incoming synchronization clock.

The two slave modes can be synchronized to an external clock through the SYNC pin. They are shown in Figure 24. The synchronization frequency should be within $\pm 30\%$ of its programmed free running frequency.

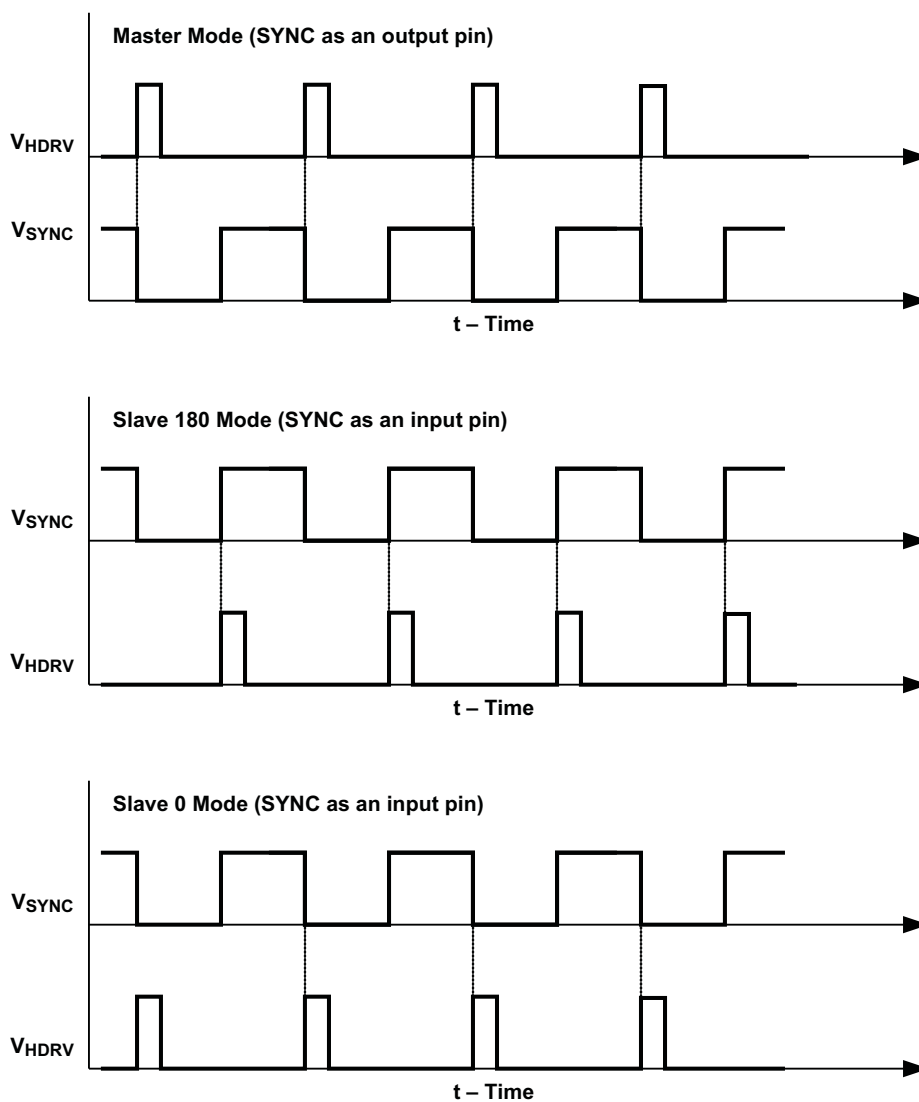

UDG-09206

Figure 24. Frequency Synchronization Waveforms in Different Modes

TPS40170 provides a smooth transition for the SYNC clock signal loss at slave mode. In slave mode, a synchronization clock signal is provided externally through the SYNC pin to the device. The switching frequency is synchronized to the external SYNC clock signal. If for some reason the external clock signal is missing, the device switching frequency is automatically overridden by a transition frequency which is 0.7 times its programmed free running frequency. This transition time is approximately 20 μs . After that, the device switching frequency is changed to its programmed free running frequency. Figure 25 shows this process.

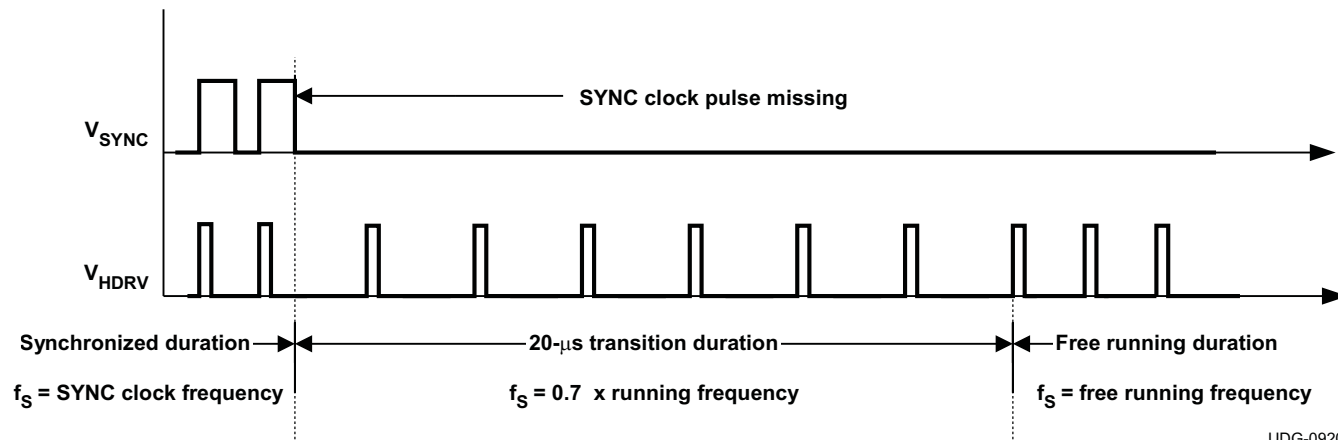

UDG-09207

Figure 25. Transition for SYNC Clock Signal Missing (for Slave-180 Mode)

NOTE

When the device is operating in the master mode with duty ratio around 50%, PWM jittering may occur. Always configure the device into the slave mode by either connecting the M/S pin to GND or leaving it floating if master mode is not used.

When external SYNC clock signal is used for synchronization, limit maximum slew rate of the clock signal to 10 V/ μs to avoid potential PWM jittering and connect the SYNC pin to the external clock signal via a 5 k Ω resistor.

The tracking function configurations and waveforms are shown in [Figure 27](#), [Figure 29](#), and [Figure 31](#) respectively.

In simultaneous voltage tracking shown in [Figure 27](#), tracking signals, VTRK1 and VTRK2, of two modules, POL1 and POL2, start up at the same time and their output voltages VOUT1initial and VOUT2initial are approximately the same during initial startup. Since VTRK1 and VTRK2 are less than VREF (0.6 V, typ), [Equation 12](#) is used. As a result, components selection should meet [Equation 14](#).

$$\left(\frac{R_1 + R_2}{R_1}\right) \times V_{TRK1} = \left(\frac{R_3 + R_4}{R_3}\right) \times V_{TRK2} \Rightarrow \frac{R_5}{R_6} = \left(\frac{\left(\frac{R_1}{R_1 + R_2}\right)}{\left(\frac{R_3}{R_3 + R_4}\right)} - 1\right) \quad (14)$$

After the lower output voltage setting reaches output voltage VOUT1 set point, where VTRK1 increases above VREF, the output voltage of the other one (VOUT2) continues increasing until it reaches its own set point, where VTRK2 increases above VREF. At that time, [Equation 13](#) is used. As a result, the resistor settings should meet [Equation 15](#) and [Equation 16](#).

$$V_{OUT1} = \left(\frac{R_1 + R_2}{R_1}\right) \times V_{REF} \quad (15)$$

$$V_{OUT2} = \left(\frac{R_3 + R_4}{R_3}\right) \times V_{REF} \quad (16)$$

[Equation 14](#) can be simplified into [Equation 17](#) by replacing with [Equation 15](#) and [Equation 16](#)

$$\left(\frac{R_5}{R_6}\right) = \left(\left(\frac{V_{OUT2}}{V_{OUT1}}\right) - 1\right) \quad (17)$$

If 5-V VOUT2 and 2.5-V VOUT1 are required, according to [Equation 15](#), [Equation 16](#) and [Equation 17](#), the selected components can be as following:

- R5 = R6 = R4 = R2 = 10 kΩ
- R1 = 3.16 kΩ
- R3 = 1.37 kΩ

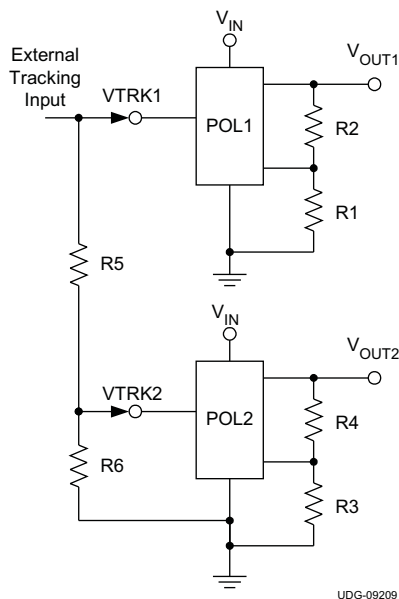

Figure 27. Simultaneous Voltage Tracking Schematic

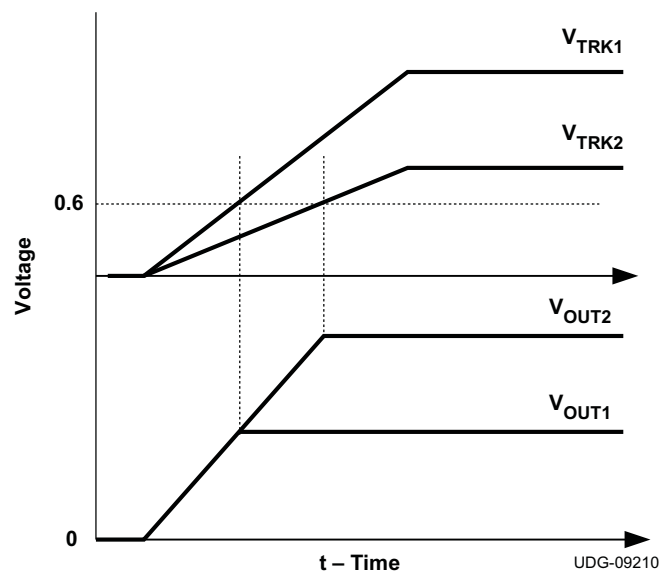
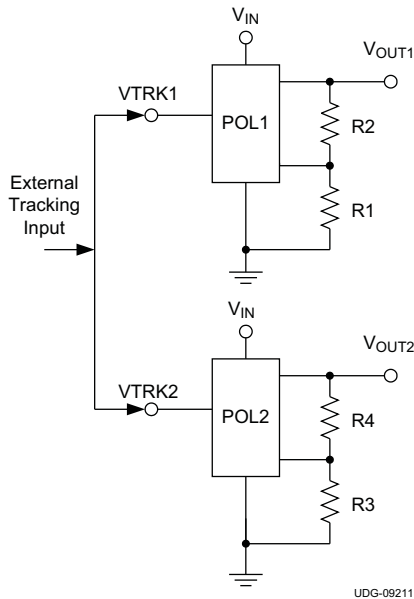
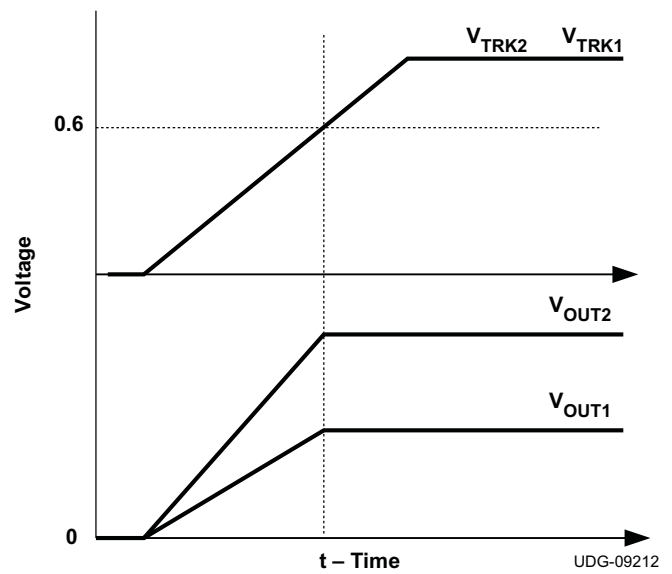

Figure 28. Simultaneous Voltage Tracking Waveform

In ratiometric voltage tracking shown in Figure 29, the two tracking voltages, VTRK1 and VTRK2, for two modules, POL1 and POL2, are the same. Their output voltage, VOUT1 and VOUT2, are different with different voltage divider R2/R1 and R4/R3. VOUT1 and VOUT2 increase proportionally and reach their output voltage set points at about the same time.



UDG-09211



UDG-09212

Figure 29. Ratiometric Voltage Tracking Schematic Figure 30. Ratiometric Voltage Tracking Waveform

Sequential startup is shown in [Figure 31](#). During start-up of the first module, POL1, its PGOOD1 is pulled to low. Since PGOOD1 is connected to soft-start SS2 of the second module, POL2, is not able to charge its soft-start capacitor. After output voltage V_{OUT1} of POL1 reaches its setting point, PGOOD1 is released. POL2 starts charging its soft-start capacitor. Finally, output voltage V_{OUT2} of POL2 reaches its setting point.

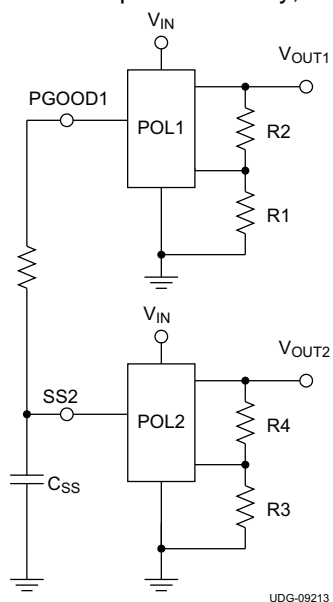
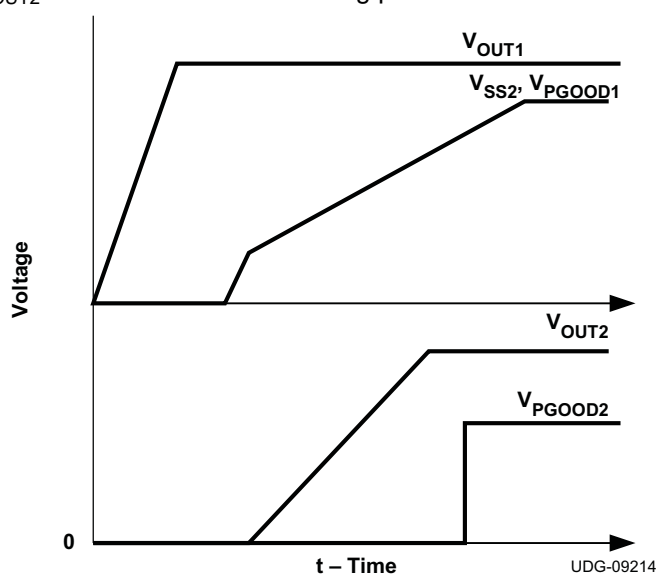
Figure 31. Sequential Start-Up Schematic

Figure 32. Sequential Start-Up Waveform
NOTE

The TRK pin has high impedance, so it is a noise sensitive terminal. If the tracking function is used, a small R-C filter is recommended at the TRK pin to filter out high-frequency noise.

If the tracking function is not used, the TRK pin must be pulled up directly or through a resistor (with a value between 10 k Ω and 100 k Ω) to VDD.

Adaptive Drivers

The drivers for the external high-side and low-side MOSFETs are capable of driving a gate-to-source voltage, V_{VBP} . The LDRV driver for the low-side MOSFET switches between VBP and PGND, while the HDRV driver for the high-side MOSFET is referenced to SW and switches between BOOT and SW. The drivers have non-overlapping timing that is governed by an adaptive delay circuit to minimize body diode conduction in the synchronous rectifier.

Start-Up Into Pre-Biased Output

The TPS40170 contains a circuit to prevent current from being pulled out of the output during startup in case the output is pre-biased. When the soft-start commands a voltage higher than the pre-bias level (internal soft-start becomes greater than feedback voltage $[V_{VFB}]$), the controller slowly activates synchronous rectification by starting the first LDRV pulses with a narrow on-time (see Figure 33), where:

- $V_{IN} = 5\text{ V}$
- $V_{OUT} = 3.3\text{ V}$
- $V_{PRE} = 1.4\text{ V}$
- $f_{SW} = 300\text{ kHz}$
- $L = 0.6\text{ }\mu\text{H}$

It then increments the on-time on a cycle-by-cycle basis until it coincides with the time dictated by $(1-D)$, where D is the duty cycle of the converter. This scheme prevents the initial sinking of the pre-bias output, and ensures that the output voltage (V_{OUT}) starts and ramps up smoothly into regulation and the control loop is given time to transition from pre-biased startup to normal mode operation with minimal disturbance to the output voltage. The time from the start of switching until the low-side MOSFET is turned on for the full $(1-D)$ interval is between approximately 20 and 40 clock cycles.

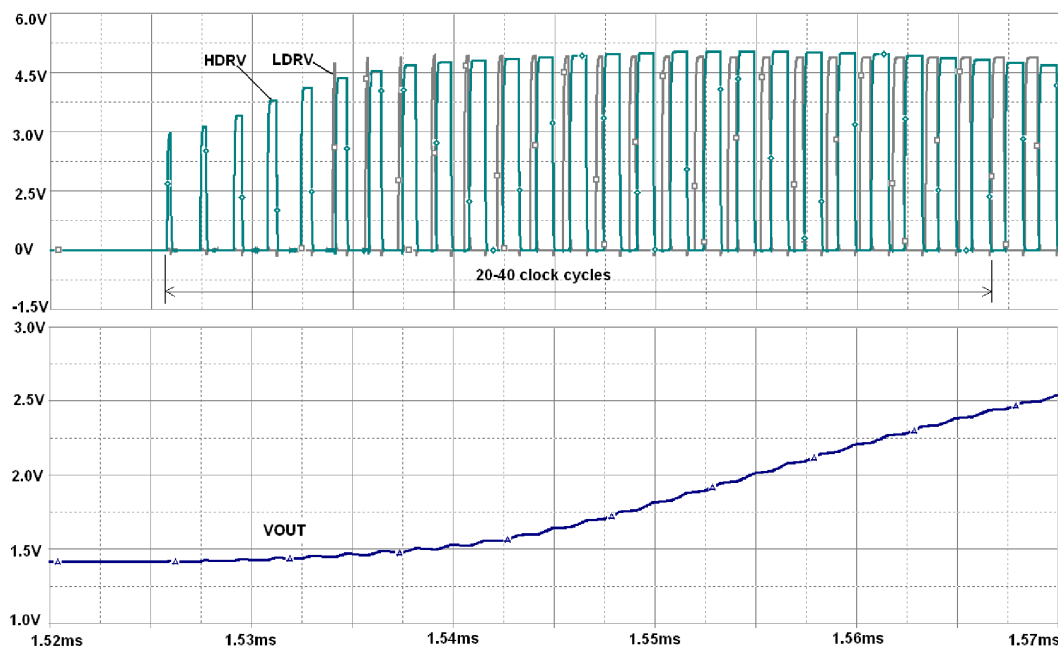

Figure 33. Start-Up Switching Waveform During Pre-Biased Condition

If the output is pre-biased to a voltage higher than the voltage commanded by the reference, then the PWM switching does not start.

NOTE

When output is pre-biased at $V_{PREBIAS}$, that voltage also applies to the SW node during start-up. When the pre-bias circuitry commands the first few high-side pulses before the first low-side pulse is initiated, the gate voltage for the high-side MOSFET is as described in [Equation 18](#). Alternatively, If pre-bias level is high, it is possible that SCP can be tripped due to high turn-on resistance of the high-side MOSFET with low gate voltage. Once tripped, the device resets and then attempts to re-start. The device may not be able to start up until output is discharged to a lower voltage level by either an active load or through feedback resistors.

In the case of a a high pre-bias level, a low gate-threshold voltage rated device is recommended for the high-side MOSFET and increasing the SCP level also helps alleviate the problem.

$$V_{GATE(HS)} = (V_{BP} - V_{DFWD} - V_{PRE-BIAS})$$

where

- $V_{GATE(HS)}$ is the gate voltage for the high-side MOSFET
- V_{BP} is the BP regulator output
- V_{DFWD} is bootstrap diode forward voltage

(18)

Power Good (PGOOD)

The TPS40170 provides an indication that the output voltage of the converter is within the specified limits of the regulation as measured at the FB pin. The PGOOD pin is an open-drain signal and pulls low when any condition exists that would indicate that the output of the supply might be out of regulation. These conditions include:

- V_{VFB} is not within the PGOOD threshold limits.
- Soft-start is active, i.e., SS pin voltage is below $V_{SS,FLT,HIGH}$ limit.
- An undervoltage condition exists for the device.
- An overcurrent or short-circuit fault is detected.
- An over-temperature fault is detected.

Figure 34 shows a situation where no fault is detected during the startup, (the normal PGOOD situation). It shows that PGOOD goes high t_{PGD} (20 μ s, typ.) after all the conditions (listed above) are met.

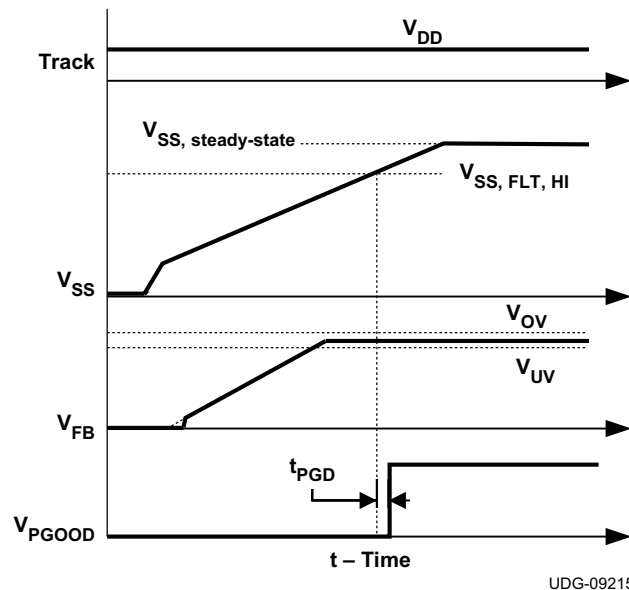

Figure 34. PGOOD Signal

When there is no power to the device, PGOOD is not able to pull close to GND if an auxiliary supply is used for the power good indication. In this case, a built-in resistor connected from drain to gate on the PGOOD pull-down device allows the PGOOD pin to operate like as a diode to GND.

PGND and AGND

NOTE

TPS40170 provides separate signal ground (AGND) and power ground (PGND) pins. PGND is primarily used for gate driver ground return. AGND is an internal logic signal ground return. These two ground signals are internally loosely connected by two anti-parallel diodes. PGND and AGND must be electrically connected externally.

Bootstrap Capacitor

A bootstrap capacitor with a value between 0.1 μ F and 0.22 μ F must be placed between the BOOT pin and the SW pin. It should be 10 times higher than MOSFET gate capacitance.

Bypass and Filtering

In an integrated circuit, supply bypassing is important for jitter-free operation. To decrease noise in the converter, ceramic bypass capacitors must be placed as close to the package as possible.

1. VIN to GND: use 0.1 μF ceramic capacitor.
2. BP to GND: use 1 μF to 10 μF ceramic capacitor. It should be 10 times higher than bootstrap capacitance
3. VDD to GND: use 0.1 μF to 1 μF ceramic capacitor

Design Hints

Bootstrap Resistor

A small resistor in series with the bootstrap capacitor reduces the turn-on time of the internal MOSFET, thereby reducing the rising edge ringing of the SW node and reduces short through induced by dv/dt . A bootstrap resistor value that is too large delays the turn-on time of the high-side switch and may trigger an apparent SCP fault. See design example.

SW Node Snubber Capacitor

Observable voltage ringing at the SW node is caused by fast switching edges and parasitic inductance and capacitance. If the ringing results in excessive voltage on the SW node, or erratic operation of the converter, an R-C snubber may be used to dampen the ringing and ensure proper operation over the full load range. See design example.

Input Resistor

The TPS40170 has a wide input voltage range which allows for the device input to share power source with power stage input. Power stage switching noise may pollute the device power source if the layout is not adequate in minimizing noise. It may trigger short-circuit fault. If so, adding a small resistor between the device input and power stage input is recommended. This resistor composites an R-C filter with the device input capacitor and filter out the switching noise from power stage. See design example.

LDRV Gate Capacitor

Power device selection is important for proper switching operation. If the low-side MOSFET has low gate capacitance C_{gs} (if $C_{gs} < C_{gd}$), there is a risk of short-through induced by high dv/dt at switching node (See reference[1]) during high-side turned-on. If this happens, add a small capacitance between LDRV and GND. See design example.

DESIGN EXAMPLES

Introduction

The wide input TPS40170 controller can function in a very wide range of applications. This example describes the design process for a very wide input (10 V to 60 V) to regulated 5-V output at a load current of 6 A. The design parameters are provide in [Table 1](#).

Table 1. Design Example Parameters

PARAMETER		TEST CONDITIONS	MIN	NOM	MAX	UNIT
V _{IN}	Input voltage		10		60	V
V _{IN(ripple)}	Input ripple	I _{OUT} = 6 A			0.5	V
V _{OUT}	Output voltage	0 A ≤ I _{OUT} ≤ 20 A	4.8	5.0	5.2	V
	Line regulation	10 V ≤ V _{IN} ≤ 60 V			0.5%	
	Load regulation	0 A ≤ I _{OUT} ≤ 6 A			0.5%	
V _{RIPPLE}	Output ripple	I _{OUT} = 6 A			100	mV
V _{OVER}	Output overshoot	ΔI _{OUT} = 2.5 A		250		mV
V _{UNDER}	Output undershoot	ΔI _{OUT} = -2.5 A		250		mV
I _{OUT}	Output current	10 V ≤ V _{IN} ≤ 60 V	0		6	A
t _{SS}	Soft-start time	V _{IN} = 24 V		4		ms
I _{SCP}	Short circuit current trip point		8			A
η	Efficiency	V _{IN} = 24 V, I _{OUT} = 6 A		94%		
f _{SW}	Switching frequency			300		kHz
	Size				1.5	in ²

Design Procedure

Select A Switching Frequency

To maintain acceptable efficiency and meet minimum on-time requirements, a 300 kHz switching frequency is selected.

Inductor Selection (L1).

Synchronous buck power inductors are typically sized for approximately 20-40% peak-to-peak ripple current (I_{RIPPLE}) Given this target ripple current, the required inductor size can be calculated in [Equation 19](#).

$$L \approx \frac{V_{IN(max)} - V_{OUT}}{0.3 \times I_{OUT}} \times \frac{V_{OUT}}{V_{IN(max)}} \times \frac{1}{f_{SW}} = \frac{60V - 5V}{0.3 \times 6A} \times \frac{5V}{60V} \times \frac{1}{300kHz} = 8.5 \mu H \quad (19)$$

Selecting a standard 8.2 μH inductor value, solving for I_{RIPPLE} = 1.86 A.

The RMS current through the inductor is approximated by [Equation 20](#).

$$I_{L(rms)} = \sqrt{\left(I_{L(avg)}\right)^2 + \left(\frac{1}{12} \times I_{RIPPLE}\right)^2} = \sqrt{\left(I_{OUT}\right)^2 + \left(\frac{1}{12} \times I_{RIPPLE}\right)^2} = \sqrt{(6)^2 + \frac{1}{12} \times (1.86)^2} = 6.02A \quad (20)$$

Output Capacitor Selection (C9)

The selection of the output capacitor is typically driven by the output transient response. The [Equation 21](#) and [Equation 22](#) overestimate the voltage deviation to account for delays in the loop bandwidth and can be used to determine the required output capacitance:

$$V_{OVER} < \frac{I_{TRAN}}{C_{OUT}} \times \Delta T = \frac{I_{TRAN}}{C_{OUT}} \times \frac{I_{TRAN} \times L}{V_{OUT}} = \frac{\left(I_{TRAN}\right)^2 \times L}{V_{OUT} \times C_{OUT}} \quad (21)$$

$$V_{\text{UNDER}} < \frac{I_{\text{TRAN}}}{C_{\text{OUT}}} \times \Delta T = \frac{I_{\text{TRAN}}}{C_{\text{OUT}}} \times \frac{I_{\text{TRAN}} \times L}{(V_{\text{IN}} - V_{\text{OUT}})} = \frac{(I_{\text{TRAN}})^2 \times L}{(V_{\text{IN}} - V_{\text{OUT}}) \times C_{\text{OUT}}} \quad (22)$$

If $V_{\text{IN}(\text{min})} > 2 \times V_{\text{OUT}}$, use overshoot to calculate minimum output capacitance. If $V_{\text{IN}(\text{min})} < 2 \times V_{\text{OUT}}$, use undershoot to calculate minimum output capacitance.

$$C_{\text{OUT}(\text{min})} = \frac{(I_{\text{TRAN}(\text{max})})^2 \times L}{V_{\text{OUT}} \times V_{\text{OVER}}} = \frac{(3)^2 \times 8.2 \mu\text{H}}{5 \times 250 \text{mV}} = 59 \mu\text{F} \quad (23)$$

With a minimum capacitance, the maximum allowable ESR is determined by the maximum ripple voltage and is approximated [Equation 24](#).

$$\text{ESR}_{\text{MAX}} = \frac{V_{\text{RIPPLE}(\text{tot})} - V_{\text{RIPPLE}(\text{cap})}}{I_{\text{RIPPLE}}} = \frac{V_{\text{RIPPLE}(\text{tot})} - \left(\frac{I_{\text{RIPPLE}}}{8 \times C_{\text{OUT}} \times f_{\text{SW}}} \right)}{I_{\text{RIPPLE}}} = \frac{100 \text{mV} - \left(\frac{1.86 \text{A}}{8 \times 59 \mu\text{F} \times 300 \text{kHz}} \right)}{1.86 \text{A}} = 47 \text{m}\Omega \quad (24)$$

Two 1210, 22- μF , 16-V X7R ceramic capacitors plus two 0805 10- μF , 16-V X7R ceramic capacitors are selected to provide more than 59 μF of minimum capacitance (including tolerance and DC bias derating) and less than 47 m Ω of ESR (parallel ESR of approximately 4 m Ω).

Peak Current Rating of Inductor

With output capacitance, it is possible to calculate the charge current during start-up and determine the minimum saturation current rating for the inductor. The start-up charging current is approximated in [Equation 25](#).

$$I_{\text{CHARGE}} = \frac{V_{\text{OUT}} \times C_{\text{OUT}}}{t_{\text{SS}}} = \frac{5 \text{V} \times (2 \times 22 \mu\text{F} + 2 \times 10 \mu\text{F})}{4 \text{ms}} = 0.08 \text{A} \quad (25)$$

$$I_{\text{L}(\text{peak})} = I_{\text{OUT}(\text{max})} + \left(\frac{1}{2} \times I_{\text{RIPPLE}} \right) + I_{\text{CHARGE}} = 6 \text{A} + \frac{1}{2} \times 1.86 \text{A} + 0.08 \text{A} = 7.01 \text{A} \quad (26)$$

An IHLP5050FDER8R2M01 8.2 μH is selected. This 10-A, 16-m Ω inductor exceeds the minimum inductor ratings in a 13 mm \times 13 mm package.

Input Capacitor Selection (C1, C6)

The input voltage ripple is divided between capacitance and ESR. For this design $V_{\text{RIPPLE}(\text{cap})} = 400 \text{mV}$ and $V_{\text{RIPPLE}(\text{ESR})} = 100 \text{mV}$. The minimum capacitance and maximum ESR are estimated by:

$$C_{\text{IN}(\text{min})} = \frac{I_{\text{LOAD}} \times V_{\text{OUT}}}{V_{\text{RIPPLE}(\text{cap})} \times V_{\text{IN}} \times f_{\text{SW}}} = \frac{6 \text{A} \times 5 \text{V}}{400 \text{mV} \times 10 \text{V} \times 300 \text{kHz}} = 25 \mu\text{F} \quad (27)$$

$$\text{ESR}_{\text{MAX}} = \frac{V_{\text{RIPPLE}(\text{esr})}}{I_{\text{LOAD}} + \frac{1}{2} \times I_{\text{RIPPLE}}} = \frac{100 \text{mV}}{6.93 \text{A}} = 14.4 \text{m}\Omega \quad (28)$$

The RMS current in the input capacitors is estimated in [Equation 29](#).

$$I_{\text{RMS}(\text{cin})} = I_{\text{LOAD}} \times \sqrt{D \times (1 - D)} = 6 \text{A} \times \sqrt{0.5 \times (1 - 0.5)} = 3.0 \text{A} \quad (29)$$

To achieve these values, four 1210, 2.2- μF , 100 V, X7R ceramic capacitors plus a 120- μF electrolytic capacitor are combined at the input. This provides a smaller size and overall cost than 10 ceramic input capacitors or an electrolytic capacitor with the ESR required.

Table 2. Inductor Summary

PARAMETER		VALUE	UNIT
L	Inductance	8.2	μH
$I_{\text{L}(\text{rms})}$	RMS current (thermal rating)	6.02	A
$I_{\text{L}(\text{peak})}$	Peak current (saturation rating)	7.01	A

MOSFET Switch Selection (Q1, Q2)

Using the J/K method for MOSFET optimization, apply [Equation 30](#) through [Equation 33](#).

High-side gate (Q1):

$$J = (10)^{-9} \times \left(\frac{V_{IN} \times I_{OUT}}{I_{DRIVE}} + \frac{Q_G}{Q_{SW}} \times V_{DRIVE} \right) \times f_{SW} \left(\frac{W}{nC} \right) \quad (30)$$

$$K = (10)^{-3} \left((I_{OUT})^2 + \frac{1}{12} \times (I_{P-P})^2 \right) \times \left(\frac{V_{OUT}}{V_{IN}} \right) \left(\frac{W}{m\Omega} \right) \quad (31)$$

Low-side gate (Q2):

$$K = (10)^{-3} \left((I_{OUT})^2 + \frac{1}{12} \times (I_{P-P})^2 \right) \times \left(1 - \frac{V_{OUT}}{V_{IN}} \right) \left(\frac{W}{m\Omega} \right) \quad (32)$$

$$J = 10^{-9} \left(\frac{V_{FD} \times I_{OUT}}{I_{DRIVE}} + \frac{Q_G}{Q_{SW}} \times V_{DRIVE} \right) \times f_{SW} \left(\frac{W}{nC} \right) \quad (33)$$

Optimizing for 300 kHz, 24-V input, 5-V output at 6 A, calculate ratios of 5.9 mΩ/nC and 0.5 mΩ/nC for the high-side and low-side FETS respectively. BSC110N06NS2 (Ratio 1.2) and BSC076N06NS3 (Ratio 0.69) MOSFETS are selected.

Timing Resistor (R7)

The switching frequency is programmed by the current through R_{RT} to GND. The R_{RT} value is calculated using [Equation 34](#).

$$R_{RT} = \frac{(10)^4}{f_{SW}} - 2k\Omega = \frac{(10)^4}{300kHz} - 2 = 31.3k\Omega \approx 31.6k\Omega \quad (34)$$

UVLO Programming Resistors (R2, R6)

The UVLO hysteresis level is programmed by R2 using [Equation 35](#).

$$R_{UVLO(hys)} = \frac{V_{UVLO(on)} - V_{UVLO(off)}}{I_{UVLO}} = \frac{9V - 8V}{5.0\mu A} = 200k\Omega \quad (35)$$

$$R_{UVLO(set)} > R_{UVLO(hys)} \frac{V_{UVLO(max)}}{(V_{UVLO_ON(min)} - V_{UVLO(max)})} = 200k\Omega \frac{0.919V}{(9.0V - 0.919V)} = 22.7k\Omega \approx 22.1k\Omega \quad (36)$$

Boot-Strap Capacitor (C7)

To ensure proper charging of the high-side FET gate, limit the ripple voltage on the boost capacitor to less than 250 mV.

$$C_{BOOST} = \frac{Q_{G1}}{V_{BOOT(ripple)}} = \frac{25nC}{250mV} = 100nF \quad (37)$$

VIN Bypass Capacitor (C18)

Place a capacitor with a value of 1.0 μF. Select a capacitor with a value between 0.1 μF and 1.0 μF, X5R or better ceramic bypass capacitor for VIN as specified in [RECOMMENDED OPERATING CONDITIONS](#). For this design a 1.0-μF, 100 V, X7R capacitor has been selected.

VBP Bypass Capacitor (C19)

Select a capacitor with a value between 1.0 μF and 10 μF, X5R or better ceramic bypass capacitor for BP as specified in [RECOMMENDED OPERATING CONDITIONS](#). For this design a 4.7-μF, 16 V capacitor has been selected.

SS Timing Capacitor (C15)

The soft-start capacitor provides smooth ramp of the error amplifier reference voltage for controlled start-up. The soft-start capacitor is selected by using [Equation 38](#).

$$C_{SS} = \frac{t_{SS}}{0.09} = \frac{4 \text{ ms}}{0.09} = 44 \text{ nF} \approx 47 \text{ nF} \quad (38)$$

ILIM Resistor (R19, C17)

The TPS40170 use the negative drop across the low-side FET at the end of the "OFF" time to measure the inductor current. Allowing for 30% over the minimum current limit for transient recovery and 20% rise in $R_{DS(on)Q2}$ for self-heating of the MOSFET, the voltage drop across the low-side FET at current limit is given by [Equation 39](#).

$$V_{OC} = \left((1.3 \times I_{OCP(min)}) + \left(\frac{1}{2} \times I_{RIPPLE} \right) \right) \times 1.25 \times R_{DS(on)G2} = (1.3 \times 8 \text{ A} + \frac{1}{2} \times 1.86 \text{ A}) \times 1.25 \times 7.6 \text{ m}\Omega = 107.6 \text{ mV} \quad (39)$$

The internal current limit temperature coefficient helps compensate for the MOSFET $R_{DS(on)}$ temperature coefficient, so the current limit programming resistor is selected by [Equation 40](#).

$$R_{CS} = \frac{V_{OC}}{I_{OCSET(min)}} = \frac{107.6 \text{ mV}}{9.0 \mu\text{A}} = 12.0 \text{ k}\Omega \approx 12.1 \text{ k}\Omega \quad (40)$$

A 1000-pF capacitor is placed in parallel to improve noise immunity of the current limit set-point.

SCP Multiplier Selection (R5)

The TPS40170 controller uses a multiplier (A_{OC}) to translate the low-side over-current protection into a high-side $R_{DS(on)}$ pulse-by-pulse short circuit protection. Ensure that [Equation 41](#) is true.

$$A_{OC} > \frac{I_{OCP(min)} + \left(\frac{1}{2} \times I_{RIPPLE} \right)}{I_{OCP(min)} + \left(\frac{1}{2} \times I_{RIPPLE} \right)} \times \frac{R_{DS(on)Q1}}{R_{DS(on)Q2}} = \frac{8 \text{ A} + \frac{1}{2} \times 1.86 \text{ A}}{8 \text{ A} + \frac{1}{2} \times 1.86 \text{ A}} \times \frac{11 \text{ m}\Omega}{7.6 \text{ m}\Omega} = 1.45 \quad (41)$$

$A_{OC} = 3$ is selected as the next greater A_{OC} . The value of R5 is set to 10 k Ω .

Feedback Divider (R10, R11)

The TPS40170 controller uses a full operational amplifier with an internally fixed 0.6-V reference. The value of R4 is selected to be between 10 k Ω and 50 k Ω for a balance of feedback current and noise immunity. With the value of R4 set to 10 k Ω , the output voltage is programmed with a resistor divider given by [Equation 42](#).

$$R10 = \frac{V_{FB} \times R11}{(V_{OUT} - V_{FB})} = \frac{0.600 \text{ V} \times 20.0 \text{ k}\Omega}{(5.0 \text{ V} - 0.600 \text{ V})} = 2.73 \text{ k}\Omega \approx 2.74 \text{ k}\Omega \quad (42)$$

Compensation: (R4, R13, C13, C14, C21)

Using the TPS40k Loop Stability Tool for a 60 kHz bandwidth and a 50° phase margin with an R10 value of 20.0 k Ω , the following values are obtained. The tool is available from the TI website, Literature Number [SLVC165](#).

- C21 = C1 = 1500 pF
- C13 = C2 = 8200 pF
- C14 = C3 = 220 pF
- R13 = R2 = 511 Ω
- R4 = R3 = 3.83 k Ω

Typical Performance Characteristics

Figure 35 shows a 10 V to 60 V to 5.0 V @ 6 A efficiency graph for this design. Figure 36 shows a 24-V to 5.0-V @ 6 A loop response where $V_{IN} = 24V$ and $I_{OUT} = 6A$, yielding 58 kHz bandwidth, 51° phase margin. Figure 37 shows the output ripple 20 mV/div, 2 μ s/div, 20 MHz bandwidth.

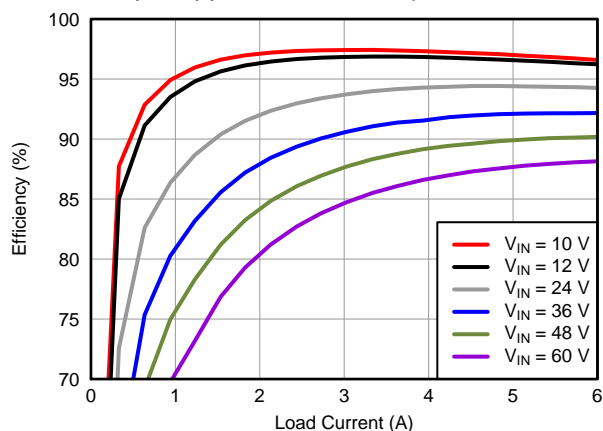

Figure 35. Efficiency vs. Load Current

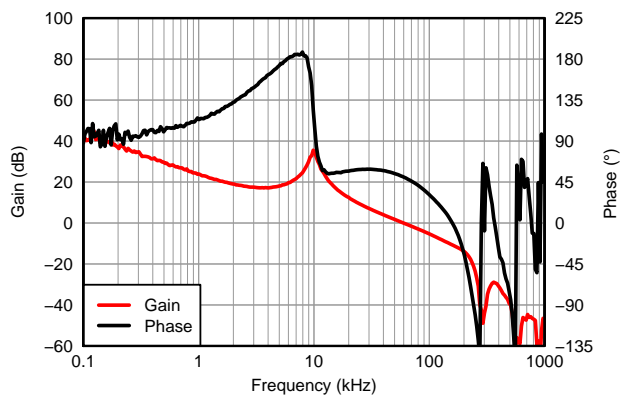

Figure 36. Loop Response

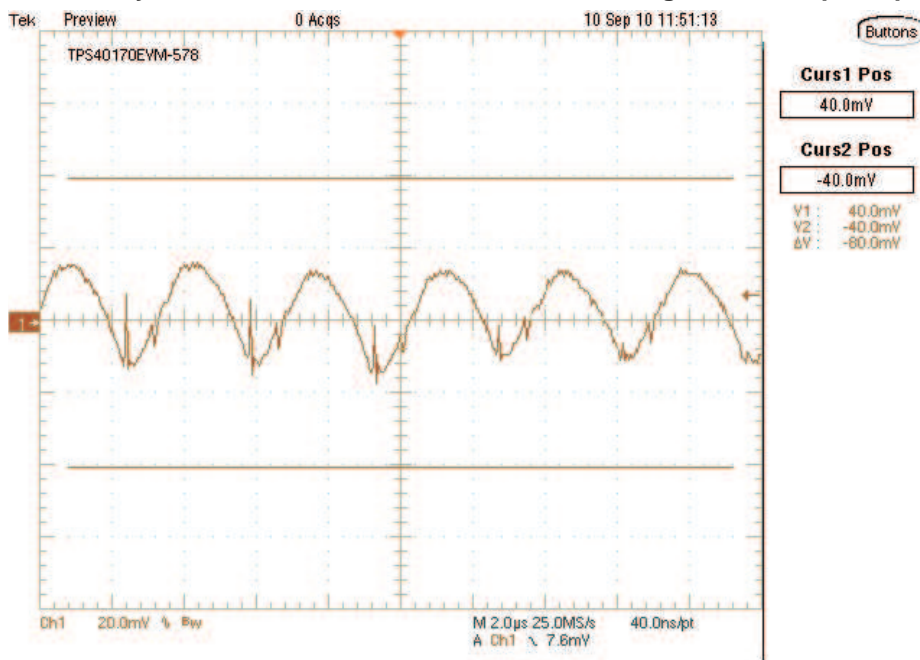
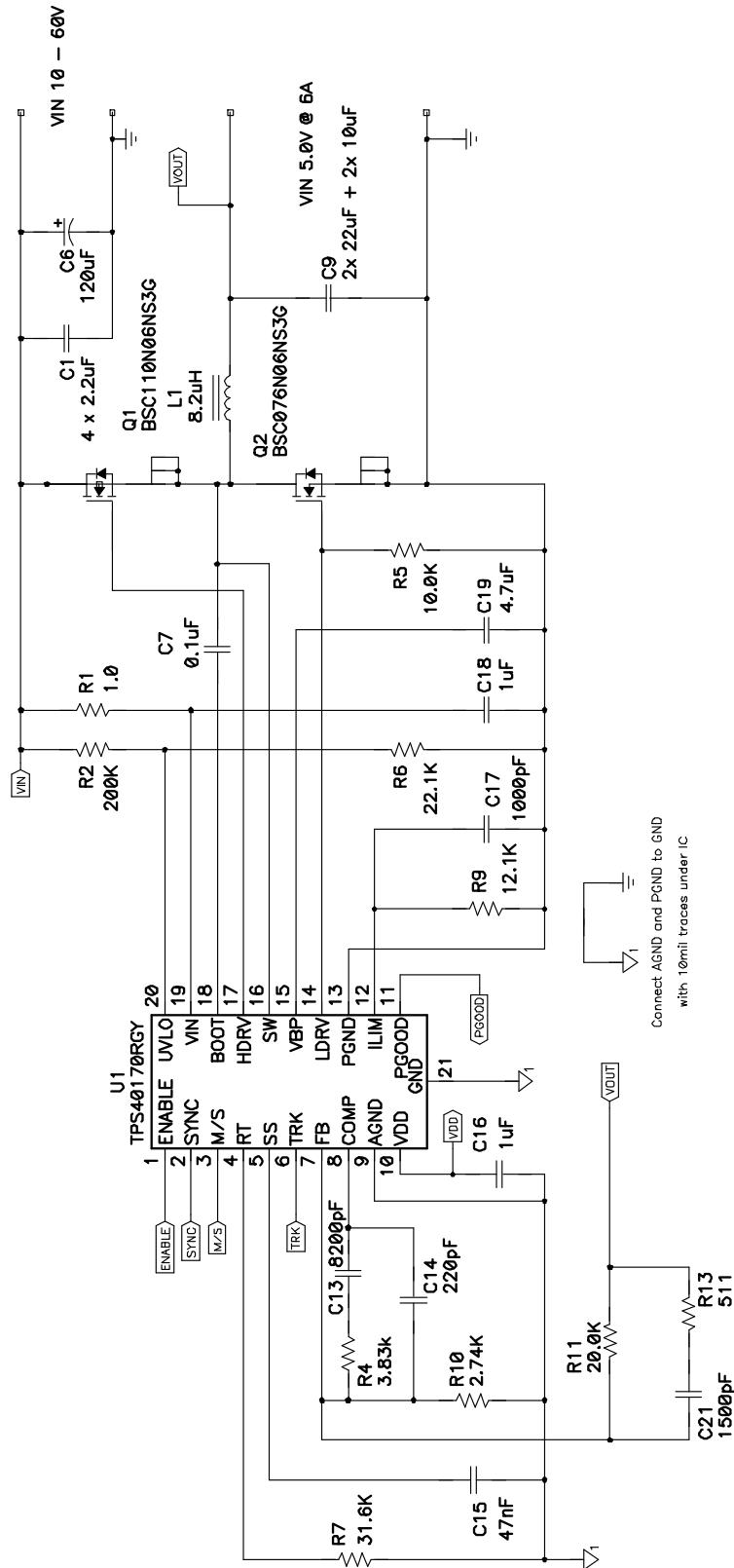

Figure 37. Output Ripple Waveform

Schematic



Connect AGND and PGND to GND with 10mil traces under IC

Figure 38. Design Example Application

List of Materials
Table 3. Design Example List of Materials

REFERENCE DESIGNATOR	QTY	VALUE	DESCRIPTION	SIZE	PART NUMBER	MANUF
C1	4	2.2 μ F	Capacitor, Ceramic, 100 V, X7R, 15%	1210	Std	Std
C6	1	120 μ F	Capacitor, Aluminum, 63 V, 20%, KZE Series	0.315"	KZE63VB121M10X16LL	Chemi-con
C7	1	0.1 μ F	Capacitor, Ceramic, 50 V, X7R, 15%	603	Std	Std
C9	2 ea	22 μ F 10 μ F	Capacitor, Ceramic, 16 V, X7R, 15%	1210	Std	Std
C13	1	8200 pF	Capacitor, Ceramic, 50 V, X7R, 15%	603	Std	Std
C14	1	220 pF	Capacitor, Ceramic, 50 V, X7R, 15%	603	Std	Std
C15	1	47 nF	Capacitor, Ceramic, 50 V, X7R, 15%	603	Std	Std
C16	1	1 μ F	Capacitor, 1 6V, X7R, 15%	603	Std	Std
C17	1	1000 pF	Capacitor, Ceramic, 50 V, X7R, 15%	603	Std	Std
C18	1	1 μ F	Capacitor, Ceramic, 100 V, X7R, 15%	1206	Std	Std
C19	1	4.7 μ F	Capacitor, Ceramic, 16 V, X5R, 15%	805	Std	Std
C21	1	1500 pF	Capacitor, Ceramic, 50 V, X7R, 15%	603	Std	Std
L1	1	8.2 μ H	Inductor, SMT, 10 A, 16 m Ω	0.51" ²	IHLP5050FDER8R2M01	Vishay
Q1	1		MOSFET, N-channel, 60 V, 50 A, 11 m Ω		BSC110N06NS3G	Infineon
Q2	1		MOSFET, N-channel, 60 V, 50 A, 7.6 m Ω		BSC076N06NS3G	Infineon
R10	1	2.74 k Ω	Resistor, Chip, 1/16W, 1%	603	Std	R603
R4	1	3.83 k Ω	Resistor, Chip, 1/16W, 1%	603	Std	R603
R5	1	10.0 k Ω	Resistor, Chip, 1/16W, 1%	603	Std	R603
R9	1	12.1 k Ω	Resistor, Chip, 1/16W, 1%	603	Std	R603
R11	1	20.0 k Ω	Resistor, Chip, 1/16W, 1%	603	Std	R603
R6	1	22.1 k Ω	Resistor, Chip, 1/16W, 1%	603	Std	R603
R7	1	31.6 k Ω	Resistor, Chip, 1/16W, 1%	603	Std	R603
R2	1	200 k Ω	Resistor, Chip, 1/16W, 1%	603	Std	R603
R13	1	511 k Ω	Resistor, Chip, 1/16W, 1%	603	Std	R603
U1			IC, 4.5 V - 60 V wide input sync. PWM buck controller		TPS40170RGY	Texas Instruments

Layout Recommendations

Figure 39 illustrates an example layout. For the controller, it is important to carefully connect noise sensitive signals such as RT, SS, FB, and comp as close to the IC as possible and connect to AGND as shown. The PowerPad should be connected to any internal PCB ground planes using multiple vias directly under the IC. The AGND and PGND should be connected at a single point.

When using high-performance FETs such as NexFET™ from Texas Instruments, careful attention to the layout is required. Minimize the distance between positive node of the input ceramic capacitor and the drain pin of the control (high-side) FET. Minimize the distance between the negative node of the input ceramic capacitor and the source pin of the synchronization (low-side) FET. Because of the large gate drive, smaller gate charge, and faster turn-on times of the high-performance FETs, it is recommended to use a minimum of 4, 10 -μF ceramic input capacitors such as TDK #C3216X5R1A106M. Ensure the layout allows a continuous flow of the power planes.

The layout of the HPA578 EVM is shown in Figure 39 through Figure 42 for reference.

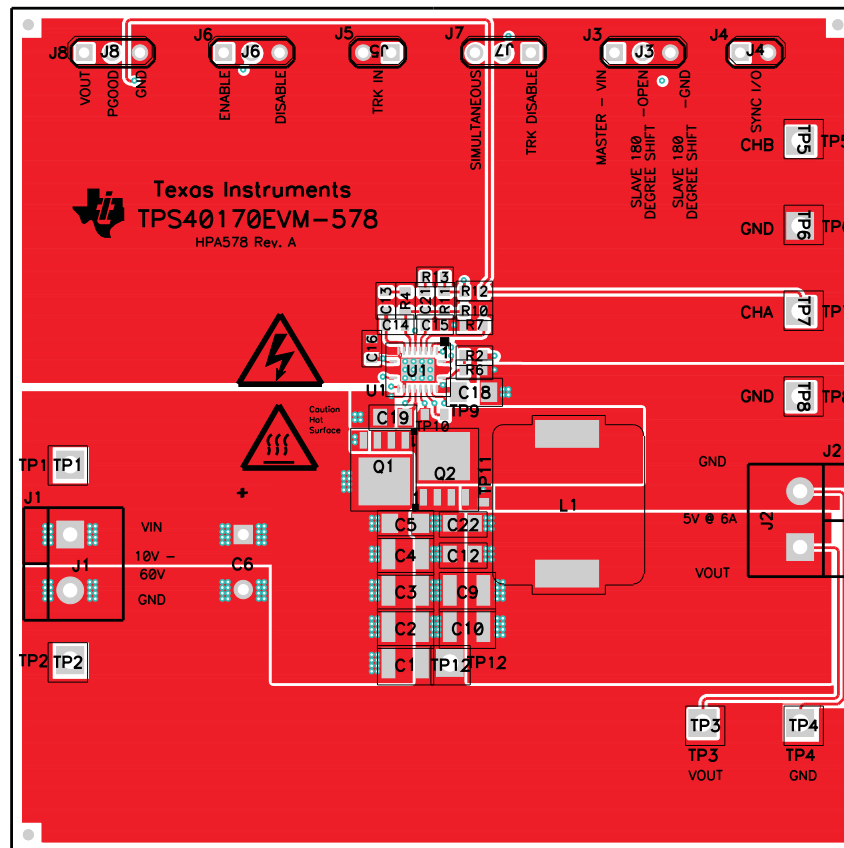

Figure 39. Top Copper, Viewed From Top

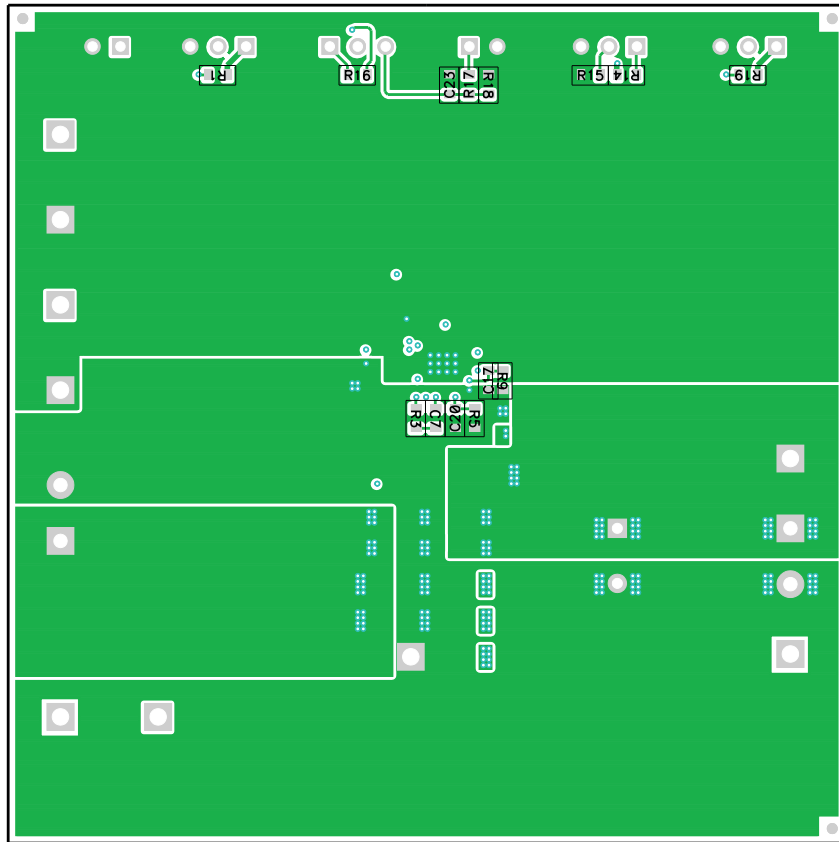

Figure 40. Bottom Copper, Viewed From Bottom

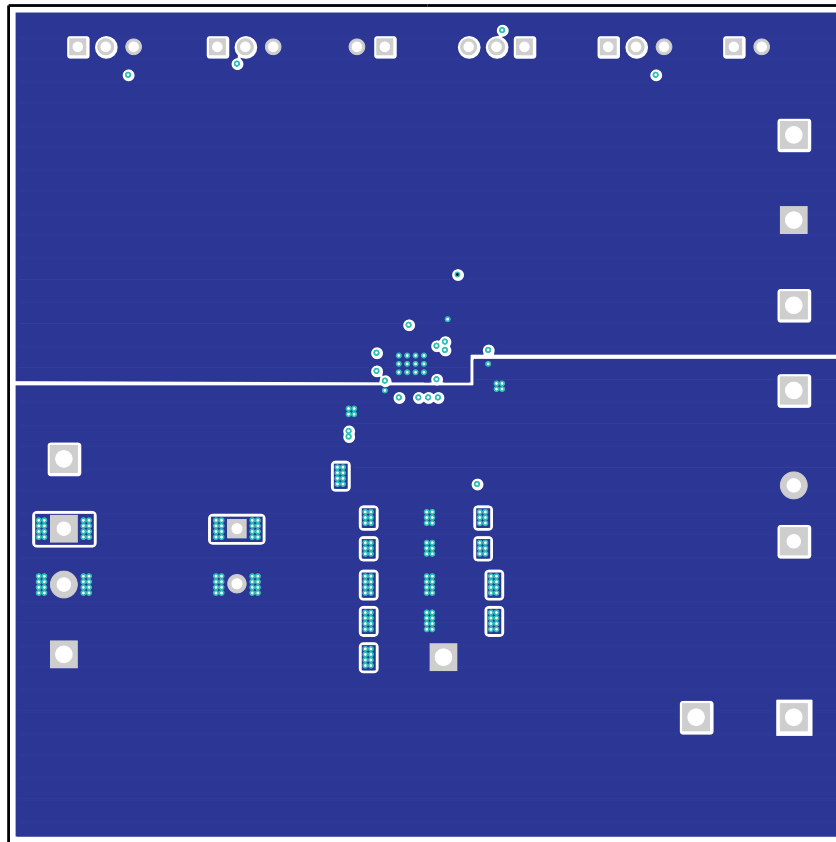

Figure 41. Internal Layer 1, Viewed From Top

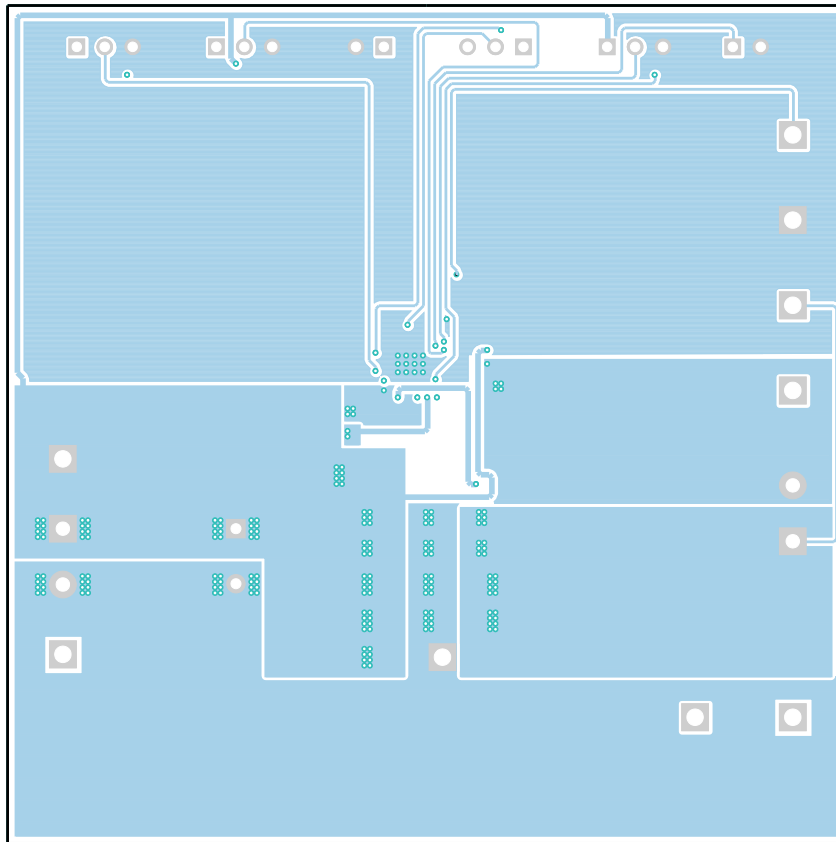

Figure 42. Internal Layer 2, Viewed From Top

TPS40170

SLUS970 – MARCH 2011

www.ti.com

ADDITIONAL REFERENCES

1. Steve Mappus, *DV/DT Immunity Improved in Synchronous Buck Converters*. July, 2005, Power Electronics Technology.

RELATED DEVICES

The following devices have characteristics similar to the TPS40170 and may be of interest.

DEVICE	DESCRIPTION	TI LITERATURE NUMBER
TPS40057	Wide Input Synchronous Buck Controller	SLUS593

PACKAGING INFORMATION

Orderable Device	Status ⁽¹⁾	Package Type	Package Drawing	Pins	Package Qty	Eco Plan ⁽²⁾	Lead/ Ball Finish	MSL Peak Temp ⁽³⁾	Samples (Requires Login)
TPS40170RGYR	ACTIVE	VQFN	RGY	20	3000	Green (RoHS & no Sb/Br)	Call TI	Level-2-260C-1 YEAR	
TPS40170RGYT	ACTIVE	VQFN	RGY	20	250	Green (RoHS & no Sb/Br)	Call TI	Level-2-260C-1 YEAR	

⁽¹⁾ The marketing status values are defined as follows:

ACTIVE: Product device recommended for new designs.

LIFEBUY: TI has announced that the device will be discontinued, and a lifetime-buy period is in effect.

NRND: Not recommended for new designs. Device is in production to support existing customers, but TI does not recommend using this part in a new design.

PREVIEW: Device has been announced but is not in production. Samples may or may not be available.

OBsolete: TI has discontinued the production of the device.

⁽²⁾ Eco Plan - The planned eco-friendly classification: Pb-Free (RoHS), Pb-Free (RoHS Exempt), or Green (RoHS & no Sb/Br) - please check <http://www.ti.com/productcontent> for the latest availability information and additional product content details.

TBD: The Pb-Free/Green conversion plan has not been defined.

Pb-Free (RoHS): TI's terms "Lead-Free" or "Pb-Free" mean semiconductor products that are compatible with the current RoHS requirements for all 6 substances, including the requirement that lead not exceed 0.1% by weight in homogeneous materials. Where designed to be soldered at high temperatures, TI Pb-Free products are suitable for use in specified lead-free processes.

Pb-Free (RoHS Exempt): This component has a RoHS exemption for either 1) lead-based flip-chip solder bumps used between the die and package, or 2) lead-based die adhesive used between the die and leadframe. The component is otherwise considered Pb-Free (RoHS compatible) as defined above.

Green (RoHS & no Sb/Br): TI defines "Green" to mean Pb-Free (RoHS compatible), and free of Bromine (Br) and Antimony (Sb) based flame retardants (Br or Sb do not exceed 0.1% by weight in homogeneous material)

⁽³⁾ MSL, Peak Temp. -- The Moisture Sensitivity Level rating according to the JEDEC industry standard classifications, and peak solder temperature.

Important Information and Disclaimer: The information provided on this page represents TI's knowledge and belief as of the date that it is provided. TI bases its knowledge and belief on information provided by third parties, and makes no representation or warranty as to the accuracy of such information. Efforts are underway to better integrate information from third parties. TI has taken and continues to take reasonable steps to provide representative and accurate information but may not have conducted destructive testing or chemical analysis on incoming materials and chemicals. TI and TI suppliers consider certain information to be proprietary, and thus CAS numbers and other limited information may not be available for release.

In no event shall TI's liability arising out of such information exceed the total purchase price of the TI part(s) at issue in this document sold by TI to Customer on an annual basis.

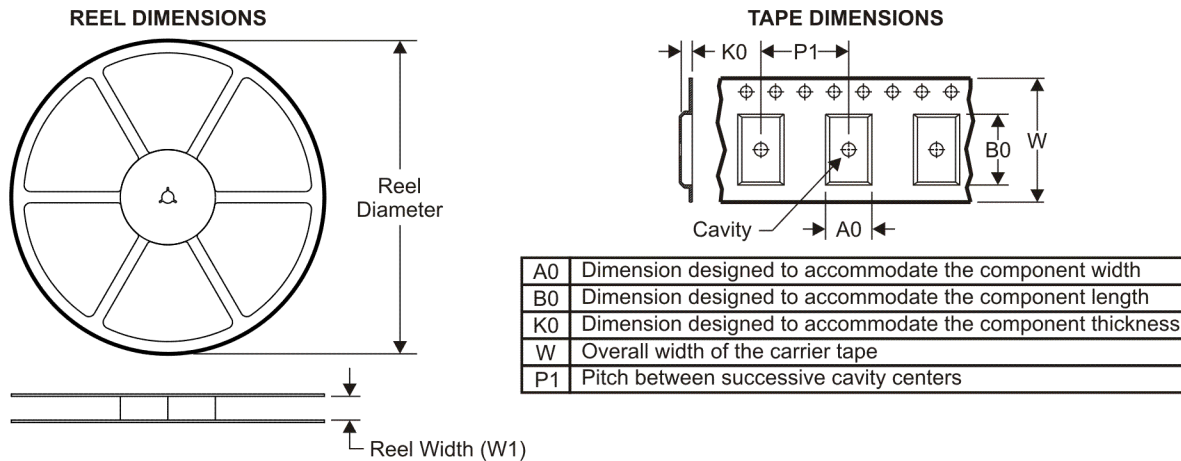
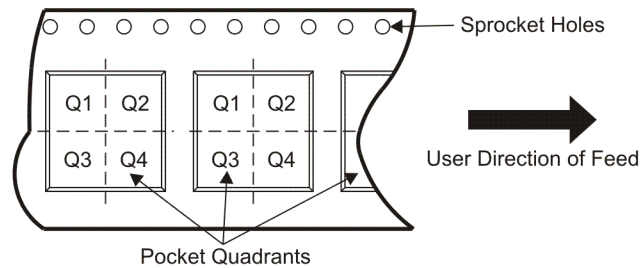
TAPE AND REEL INFORMATION

QUADRANT ASSIGNMENTS FOR PIN 1 ORIENTATION IN TAPE

*All dimensions are nominal

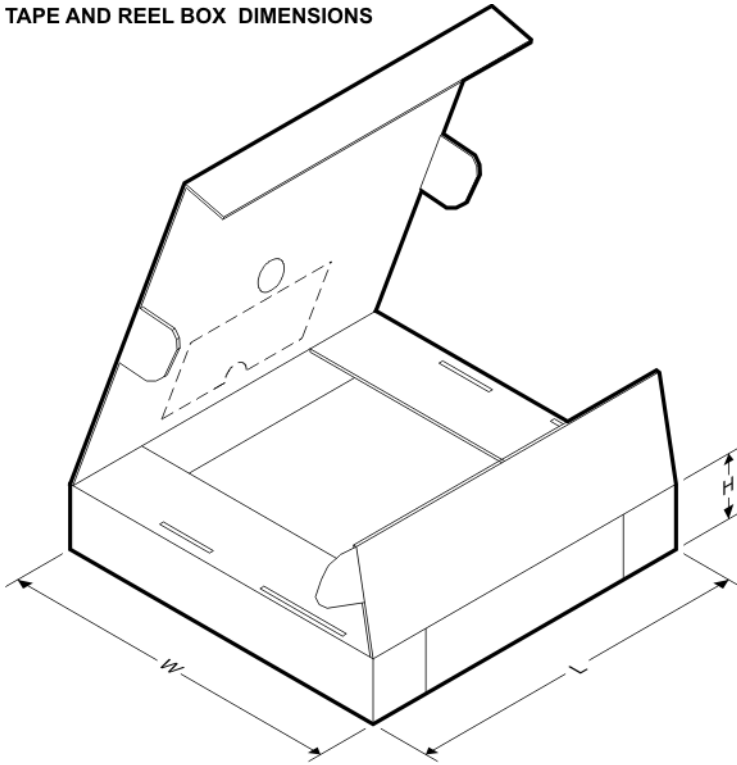
Device	Package Type	Package Drawing	Pins	SPQ	Reel Diameter (mm)	Reel Width W1 (mm)	A0 (mm)	B0 (mm)	K0 (mm)	P1 (mm)	W (mm)	Pin1 Quadrant
TPS40170RGYR	VQFN	RGY	20	3000	330.0	12.4	3.8	4.8	1.6	8.0	12.0	Q1
TPS40170RGYT	VQFN	RGY	20	250	180.0	12.4	3.8	4.8	1.6	8.0	12.0	Q1

TAPE AND REEL BOX DIMENSIONS

*All dimensions are nominal

Device	Package Type	Package Drawing	Pins	SPQ	Length (mm)	Width (mm)	Height (mm)
TPS40170RGYR	VQFN	RGY	20	3000	346.0	346.0	29.0
TPS40170RGYT	VQFN	RGY	20	250	190.5	212.7	31.8

RGY (R-PVQFN-N20)

PLASTIC QUAD FLATPACK NO-LEAD

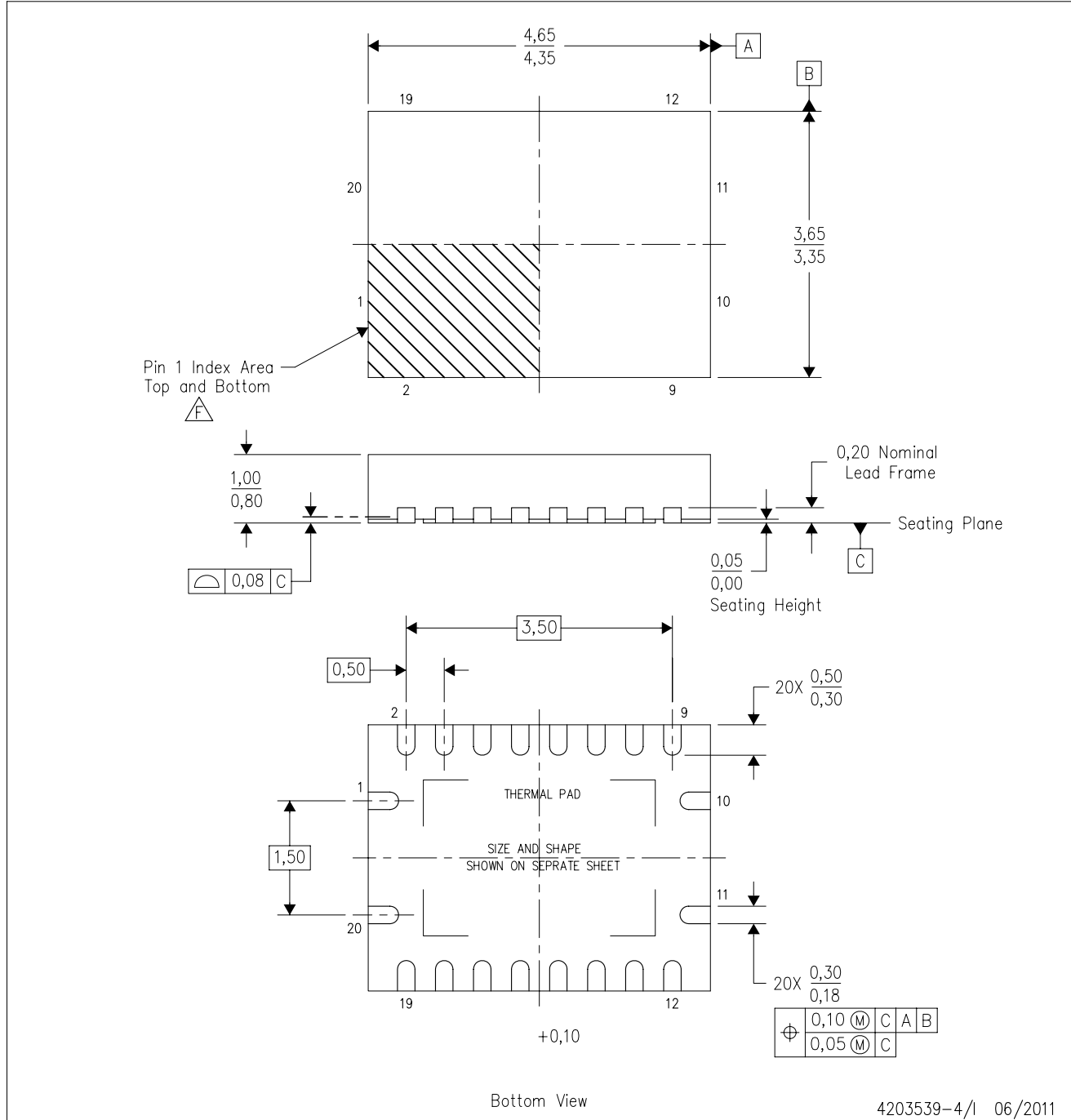

- NOTES:
- A. All linear dimensions are in millimeters. Dimensioning and tolerancing per ASME Y14.5M-1994.
 - B. This drawing is subject to change without notice.
 - C. QFN (Quad Flatpack No-Lead) package configuration.
 - D. The package thermal pad must be soldered to the board for thermal and mechanical performance.
 - E. See the additional figure in the Product Data Sheet for details regarding the exposed thermal pad features and dimensions.
 - F. Pin 1 identifiers are located on both top and bottom of the package and within the zone indicated. The Pin 1 identifiers are either a molded, marked, or metal feature.
 - G. Package complies to JEDEC MO-241 variation BA.

RGY (R-PVQFN-N20)

PLASTIC QUAD FLATPACK NO-LEAD

THERMAL INFORMATION

This package incorporates an exposed thermal pad that is designed to be attached directly to an external heatsink. The thermal pad must be soldered directly to the printed circuit board (PCB). After soldering, the PCB can be used as a heatsink. In addition, through the use of thermal vias, the thermal pad can be attached directly to the appropriate copper plane shown in the electrical schematic for the device, or alternatively, can be attached to a special heatsink structure designed into the PCB. This design optimizes the heat transfer from the integrated circuit (IC).

For information on the Quad Flatpack No-Lead (QFN) package and its advantages, refer to Application Report, QFN/SON PCB Attachment, Texas Instruments Literature No. SLUA271. This document is available at www.ti.com.

The exposed thermal pad dimensions for this package are shown in the following illustration.

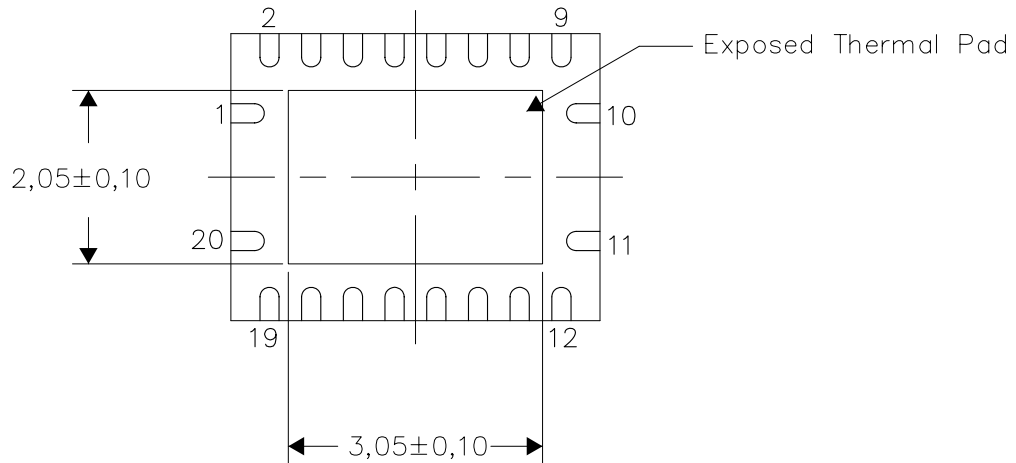

Bottom View

Exposed Thermal Pad Dimensions

4206353-4/N 06/11

NOTE: A. All linear dimensions are in millimeters

RGY (R-PVQFN-N20)

PLASTIC QUAD FLATPACK NO-LEAD

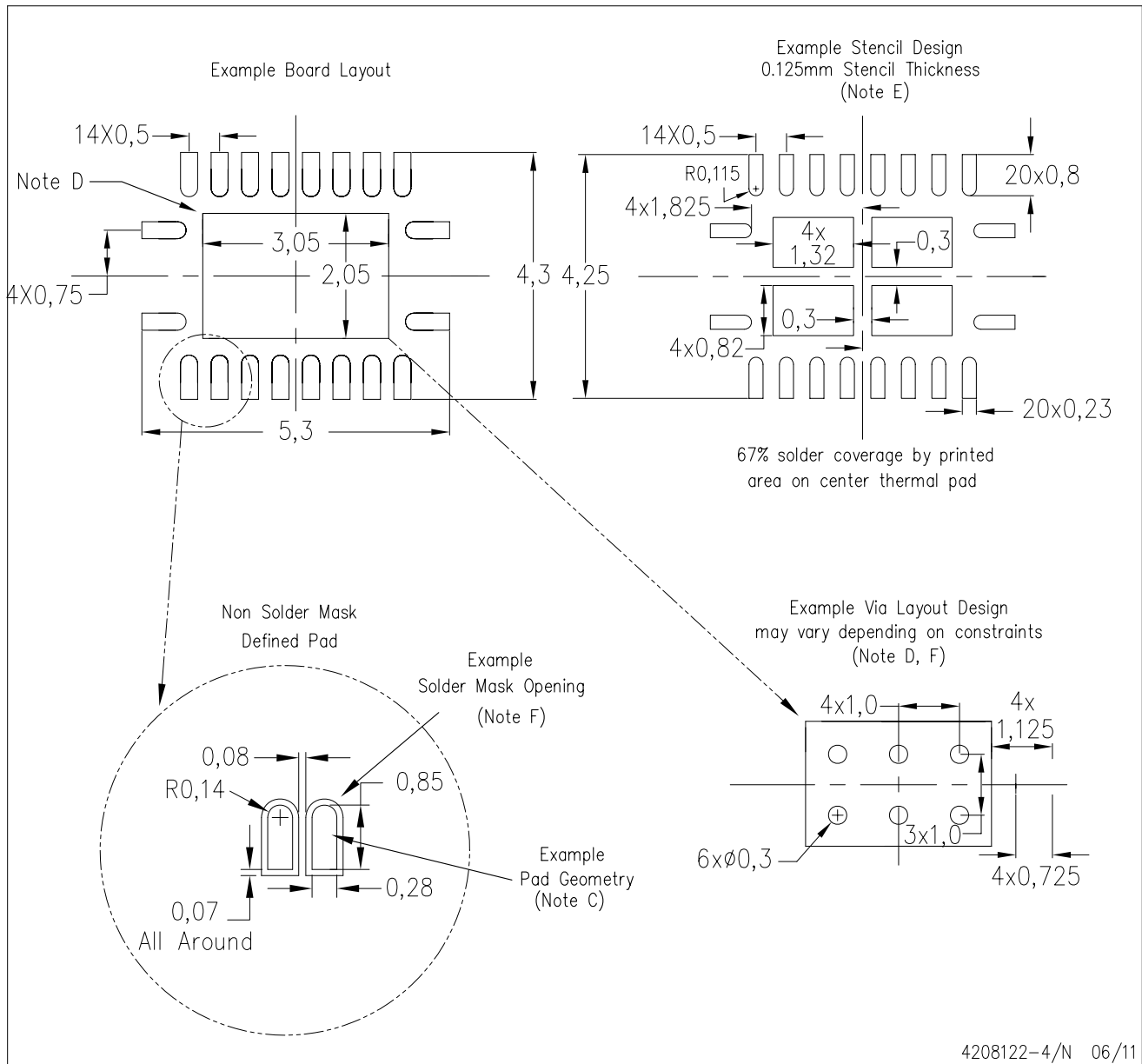

4208122-4/N 06/11

- NOTES:
- All linear dimensions are in millimeters.
 - This drawing is subject to change without notice.
 - Publication IPC-7351 is recommended for alternate designs.
 - This package is designed to be soldered to a thermal pad on the board. Refer to Application Note, Quad Flat-Pack QFN/SON PCB Attachment, Texas Instruments Literature No. SLUA271, and also the Product Data Sheets for specific thermal information, via requirements, and recommended board layout. These documents are available at www.ti.com <<http://www.ti.com>>.
 - Laser cutting apertures with trapezoidal walls and also rounding corners will offer better paste release. Customers should contact their board assembly site for stencil design recommendations. Refer to IPC 7525 for stencil design considerations.
 - Customers should contact their board fabrication site for minimum solder mask web tolerances between signal pads.

IMPORTANT NOTICE

Texas Instruments Incorporated and its subsidiaries (TI) reserve the right to make corrections, modifications, enhancements, improvements, and other changes to its products and services at any time and to discontinue any product or service without notice. Customers should obtain the latest relevant information before placing orders and should verify that such information is current and complete. All products are sold subject to TI's terms and conditions of sale supplied at the time of order acknowledgment.

TI warrants performance of its hardware products to the specifications applicable at the time of sale in accordance with TI's standard warranty. Testing and other quality control techniques are used to the extent TI deems necessary to support this warranty. Except where mandated by government requirements, testing of all parameters of each product is not necessarily performed.

TI assumes no liability for applications assistance or customer product design. Customers are responsible for their products and applications using TI components. To minimize the risks associated with customer products and applications, customers should provide adequate design and operating safeguards.

TI does not warrant or represent that any license, either express or implied, is granted under any TI patent right, copyright, mask work right, or other TI intellectual property right relating to any combination, machine, or process in which TI products or services are used. Information published by TI regarding third-party products or services does not constitute a license from TI to use such products or services or a warranty or endorsement thereof. Use of such information may require a license from a third party under the patents or other intellectual property of the third party, or a license from TI under the patents or other intellectual property of TI.

Reproduction of TI information in TI data books or data sheets is permissible only if reproduction is without alteration and is accompanied by all associated warranties, conditions, limitations, and notices. Reproduction of this information with alteration is an unfair and deceptive business practice. TI is not responsible or liable for such altered documentation. Information of third parties may be subject to additional restrictions.

Resale of TI products or services with statements different from or beyond the parameters stated by TI for that product or service voids all express and any implied warranties for the associated TI product or service and is an unfair and deceptive business practice. TI is not responsible or liable for any such statements.

TI products are not authorized for use in safety-critical applications (such as life support) where a failure of the TI product would reasonably be expected to cause severe personal injury or death, unless officers of the parties have executed an agreement specifically governing such use. Buyers represent that they have all necessary expertise in the safety and regulatory ramifications of their applications, and acknowledge and agree that they are solely responsible for all legal, regulatory and safety-related requirements concerning their products and any use of TI products in such safety-critical applications, notwithstanding any applications-related information or support that may be provided by TI. Further, Buyers must fully indemnify TI and its representatives against any damages arising out of the use of TI products in such safety-critical applications.

TI products are neither designed nor intended for use in military/aerospace applications or environments unless the TI products are specifically designated by TI as military-grade or "enhanced plastic." Only products designated by TI as military-grade meet military specifications. Buyers acknowledge and agree that any such use of TI products which TI has not designated as military-grade is solely at the Buyer's risk, and that they are solely responsible for compliance with all legal and regulatory requirements in connection with such use.

TI products are neither designed nor intended for use in automotive applications or environments unless the specific TI products are designated by TI as compliant with ISO/TS 16949 requirements. Buyers acknowledge and agree that, if they use any non-designated products in automotive applications, TI will not be responsible for any failure to meet such requirements.

Following are URLs where you can obtain information on other Texas Instruments products and application solutions:

Products

Audio	www.ti.com/audio
Amplifiers	amplifier.ti.com
Data Converters	dataconverter.ti.com
DLP® Products	www.dlp.com
DSP	dsp.ti.com
Clocks and Timers	www.ti.com/clocks
Interface	interface.ti.com
Logic	logic.ti.com
Power Mgmt	power.ti.com
Microcontrollers	microcontroller.ti.com
RFID	www.ti-rfid.com
RF/IF and ZigBee® Solutions	www.ti.com/lprf

Applications

Communications and Telecom	www.ti.com/communications
Computers and Peripherals	www.ti.com/computers
Consumer Electronics	www.ti.com/consumer-apps
Energy and Lighting	www.ti.com/energy
Industrial	www.ti.com/industrial
Medical	www.ti.com/medical
Security	www.ti.com/security
Space, Avionics and Defense	www.ti.com/space-avionics-defense
Transportation and Automotive	www.ti.com/automotive
Video and Imaging	www.ti.com/video
Wireless	www.ti.com/wireless-apps

TI E2E Community Home Page

e2e.ti.com

Mailing Address: Texas Instruments, Post Office Box 655303, Dallas, Texas 75265
Copyright © 2011, Texas Instruments Incorporated