



## HIGH-EFFICIENCY MIDRANGE INPUT SYNCHRONOUS BUCK CONTROLLER WITH VOLTAGE FEED-FORWARD

### FEATURES

- Operation Over 4.5-V to 28-V Input Range
- Programmable Fixed-Frequency up to 1-MHz Voltage-Mode Controller
- Predictive Gate Drive™ With Anti-Cross Conduction Circuitry
- <1% Internal 700-mV Reference
- Internal Gate Drive Outputs for High-Side and Synchronous N-Channel MOSFETs
- 16-Pin PowerPAD™ Package
- Thermal Shutdown Protection
- TPS40070: Source Only
- TPS40071: Source/Sink
- Programmable High-Side Sense Short Circuit Protection

### DESCRIPTION

The TPS4007x is a mid voltage, wide input (4.5 V to 28 V), synchronous, step-down converter.

The TPS4007x offers design flexibility with a variety of user programmable functions, including; soft-start, UVLO, operating frequency, voltage feed-forward and high-side FET sensed short circuit protection.

The TPS4007x incorporates MOSFET gate drivers for external N-channel high-side and synchronous rectifier (SR) MOSFETs. Gate drive logic incorporates predictive anti-cross conduction circuitry to prevent simultaneous high-side and synchronous rectifier conduction, while minimizing and eliminating current flow in the body diode of the SR FET. The TPS40071 allows the supply output to sink current at all times. The TPS40070 implements a source-only power supply.

### APPLICATIONS

- Power Modules
- Networking/Telecom
- PCI Express
- Industrial
- Servers

### SIMPLIFIED APPLICATION DIAGRAM

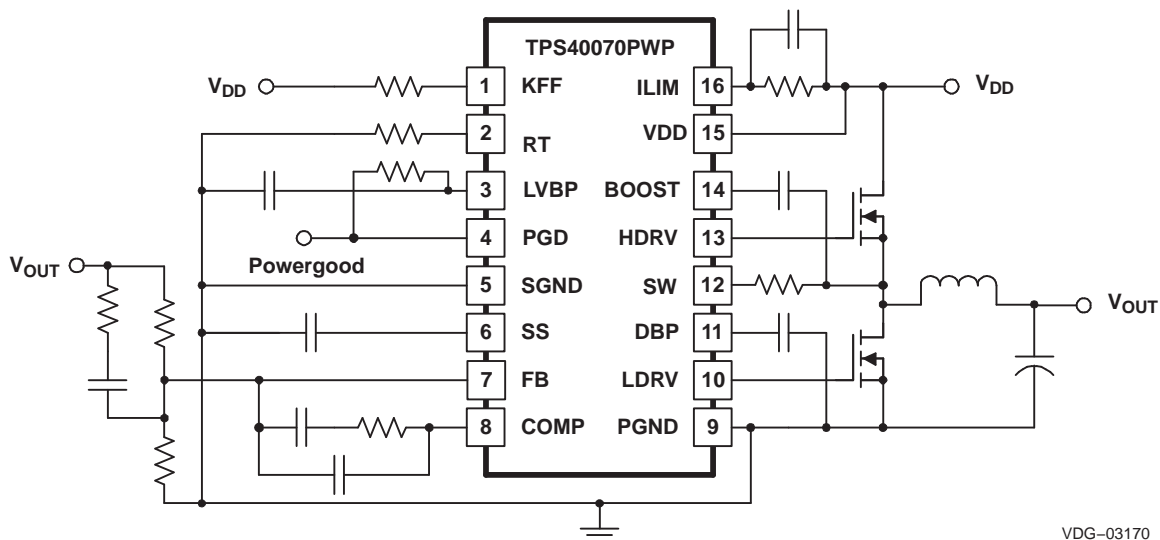

VDG-03170



Please be aware that an important notice concerning availability, standard warranty, and use in critical applications of Texas Instruments semiconductor products and disclaimers thereto appears at the end of this data sheet.

Predictive Gate Drive, PowerPAD are trademarks of Texas Instruments.

## DESCRIPTION (CONTINUED)

The TPS4007x uses voltage feed-forward control techniques to provide good line regulation over a wide-input voltage range, and fast response to input line transients with near constant gain with input variation to ease loop compensation. The externally programmable short circuit protection provides fault current limiting, as well as hiccup mode operation for thermal protection in the presence of a shorted output. The TPS4007x is packaged in a 16-pin PowerPAD package for better thermal performance at higher voltages and frequencies. See SLMA002 for information on board layout for the PowerPAD package. The pcb pad that the PowerPAD solders to should be connected to GND. Due to the die attach method, the PowerPAD itself cannot be used as the device ground connection. The two device grounds must be connected as well.

## ORDERING INFORMATION

T <sub>A</sub>	APPLICATION	PACKAGE	PART NUMBER
40°C to 85°C	SOURCE ONLY <sup>(1)</sup>	Plastic HTSSOP (PWP) <sup>(2)</sup>	TPS40070PWP
	SOURCE/SINK <sup>(1)</sup>	Plastic HTSSOP (PWP) <sup>(2)</sup>	TPS40071PWP

(1) See *Application Information* section and Table 1.

(2) The PWP package is also available taped and reeled. Add an R suffix to the device type (i.e., TPS40070PWPR). See the application section of the data sheet for PowerPAD drawing and layout information.

## ABSOLUTE MAXIMUM RATINGS

over operating free-air temperature range unless otherwise noted<sup>(1)</sup>

		TPS40070 TPS40071	UNIT
V <sub>DD</sub> Input voltage range	VDD, ILIM	30	V
	COMP, FB, KFF, PGD, LVBP	-0.3 to 6	
	SW	-0.3 to 40	
	SW, transient < 50 ns	-2.5	
V <sub>OUT</sub> Output voltage range	COMP, KFF, RT, SS	-0.3 to 6	V
	VBOOST	50	
	DBP	10.5	
	LVBP	6	
I <sub>OUT</sub> Output current source	LDRV, HDRV	1.5	A
I <sub>OUT</sub> Output current sink	LDRV, HDRV	2.0	
	KFF	10	mA
Output current	RT	1	
	LVBP	1.5	
T <sub>J</sub> Operating junction temperature range		-40 to 125	°C
T <sub>stg</sub> Storage temperature		-55 to 150	
Lead temperature 1,6 mm (1/16 inch) from case for 10 seconds		260	

(1) Stresses beyond those listed under "absolute maximum ratings" may cause permanent damage to the device. These are stress ratings only, and functional operation of the device at these or any other conditions beyond those indicated under "recommended operating conditions" is not implied. Exposure to absolute-maximum-rated conditions for extended periods may affect device reliability.

## RECOMMENDED OPERATING CONDITIONS

		MIN	NOM	MAX	UNIT
V <sub>DD</sub>	Input voltage	4.5		28	V
T <sub>A</sub>	Operating free-air temperature	-40		85	°C

## ELECTRICAL CHARACTERISTICS

$T_A = -40^{\circ}\text{C}$  to  $85^{\circ}\text{C}$ ,  $V_{IN} = 12\text{ V}_{\text{dc}}$ ,  $R_T = 90.9\text{ k}\Omega$ ,  $I_{\text{KFF}} = 300\text{ A}$ ,  $f_{\text{SW}} = 500\text{ kHz}$ , all parameters at zero power dissipation (unless otherwise noted)

PARAMETER		TEST CONDITIONS	MIN	TYP	MAX	UNIT
<b>INPUT SUPPLY</b>						
$V_{\text{DD}}$	Input voltage range, $V_{\text{IN}}$		4.5		28	V
<b>OPERATING CURRENT</b>						
$I_{\text{DD}}$	Quiescent current	Output drivers not switching		2.5	3.5	mA
<b>LVBP</b>						
$V_{\text{LVBP}}$	Output voltage	$T_A = T_J = 25^{\circ}\text{C}$	3.9	4.2	4.5	V
<b>OSCILLATOR/RAMP GENERATOR</b> <sup>(1)</sup>						
$f_{\text{OSC}}$	Accuracy		450	500	550	kHz
$V_{\text{RAMP}}$	PWM ramp voltage <sup>(2)</sup>	$V_{\text{PEAK}} - V_{\text{VAL}}$		2.0		V
$V_{\text{RT}}$	RT voltage		2.23	2.40	2.58	V
$t_{\text{ON}}$	Minimum output pulse time <sup>(2)</sup>	$C_{\text{HDRV}} = 0\text{ nF}$			250	ns
	Maximum duty cycle	$V_{\text{FB}} = 0\text{ V}$ , $100\text{ kHz} \leq f_{\text{SW}} \leq 500\text{ kHz}$	84%		93%	
		$V_{\text{FB}} = 0\text{ V}$ , $f_{\text{SW}} = 1\text{ MHz}$	76%		93%	
$V_{\text{KFF}}$	Feed-forward voltage		0.35	0.40	0.45	V
$I_{\text{KFF}}$	Feed-forward current operating range <sup>(2)</sup>		20		1100	$\mu\text{A}$
<b>SOFT START</b>						
$I_{\text{SS}}$	Charge current		7	12	17	$\mu\text{A}$
$t_{\text{DSCH}}$	Discharge time	$C_{\text{SS}} = 3.9\text{ nF}$	25		75	$\mu\text{s}$
$t_{\text{SS}}$	Soft-start time	$C_{\text{SS}} = 3.9\text{ nF}$ , $V_{\text{SS}}$ rising from 0.7 V to 1.6 V	210	290	500	$\mu\text{s}$
	Command zero output voltage <sup>(1)</sup>		300			mV
<b>DBP</b>						
$V_{\text{DBP}}$	Output voltage	$V_{\text{DD}} > 10\text{ V}$	7	8	9	V
		$V_{\text{DD}} = 4.5\text{ V}$ , $I_{\text{OUT}} = 25\text{ mA}$	4.0	4.3		
<b>ERROR AMPLIFIER</b>						
$V_{\text{FB}}$	Feedback regulation voltage total variation	$T_A = T_J = 25^{\circ}\text{C}$	0.698	0.700	0.704	V
		$0^{\circ}\text{C} \leq T_A \leq 85^{\circ}\text{C}$	0.690	0.700	0.707	
		$40^{\circ}\text{C} \leq T_A \leq 85^{\circ}\text{C}$	0.690	0.700	0.715	
$V_{\text{SS}}$	Soft-start offset from $V_{\text{SS}}$ <sup>(2)</sup>	Offset from $V_{\text{SS}}$ to error amplifier		1		
$G_{\text{BW}}$	Gain bandwidth <sup>(2)</sup>		5	10		MHz
$A_{\text{VOL}}$	Open loop gain		50			dB
$I_{\text{SRC}}$	Output source current		2.5	4.5		mA
$I_{\text{SINK}}$	Output sink current		2.5	6		
$I_{\text{BIAS}}$	Input bias current	$V_{\text{FB}} = 0.7\text{ V}$	-250		0	nA

(1) For zero output voltage only. Does not assure lack of activity on HDRV or LDRV.

(2) Ensured by design. Not production tested.

**ELECTRICAL CHARACTERISTICS (continued)**

T<sub>A</sub> = -40°C to 85°C, V<sub>IN</sub> = 12 V<sub>dc</sub>, R<sub>T</sub> = 90.9 kΩ, I<sub>KFF</sub> = 300 A, f<sub>SW</sub> = 500 kHz, all parameters at zero power dissipation (unless otherwise noted)

PARAMETER		TEST CONDITIONS	MIN	TYP	MAX	UNIT
<b>SHORT CIRCUIT CURRENT PROTECTION</b>						
I <sub>ILIM</sub>	Current sink into current limit		80	105	125	μA
V <sub>ILIM(ofst)</sub>	Current limit offset voltage	V <sub>ILIM</sub> = 11.5 V, (V <sub>SW</sub> - V <sub>ILIM</sub> ) V <sub>DD</sub> = 12 V	-75	-50	-30	mV
t <sub>HSC</sub>	Minimum HDRV pulse width	During short circuit		135	225	ns
	Propagation delay to output <sup>(3)</sup>			50		ns
t <sub>BLANK</sub>	Blanking time <sup>(3)</sup>			50		ns
t <sub>OFF</sub>	Off time during a fault (SS cycle times)			7		cycles
V <sub>SW</sub>	Switching level to end precondition <sup>(3)</sup>	(V <sub>DD</sub> - V <sub>SW</sub> )		2		V
t <sub>PC</sub>	Precondition time <sup>(3)</sup>				100	ns
V <sub>ILIM</sub>	Current limit precondition voltage threshold <sup>(3)</sup>			6.8		V
<b>OUTPUT DRIVERS</b>						
t <sub>HFALL</sub>	High-side driver fall time <sup>(3)</sup>	C <sub>HDRV</sub> = 2200 pF, (HDRV - SW)		36		ns
t <sub>HRISE</sub>	High-side driver rise time <sup>(3)</sup>			48		
t <sub>HFALL</sub>	High-side driver fall time <sup>(3)</sup>	C <sub>HDRV</sub> = 2200 pF, (HDRV - SW) V <sub>DD</sub> = 4.5 V, 0.2 V ≤ V <sub>SS</sub> ≤ 4 V		72		ns
t <sub>HRISE</sub>	High-side driver rise time <sup>(3)</sup>			96		
t <sub>LFALL</sub>	Low-side driver fall time <sup>(3)</sup>	C <sub>LDRV</sub> = 2200 pF		24		ns
t <sub>LRISE</sub>	Low-side driver rise time <sup>(3)</sup>			48		
t <sub>LFALL</sub>	Low-side driver fall time <sup>(3)</sup>	C <sub>LDRV</sub> = 2200 pF, V <sub>DD</sub> = 4.5 V, 0.2 V ≤ V <sub>SS</sub> ≤ 4 V		48		ns
t <sub>LRISE</sub>	Low-side driver rise time <sup>(3)</sup>			96		
V <sub>OH</sub>	High-level output voltage, HDRV	I <sub>HDRV</sub> = -0.01 A, (V <sub>BOOST</sub> - V <sub>HDRV</sub> )		0.7	1.0	V
		I <sub>HDRV</sub> = -0.1 A, (V <sub>BOOST</sub> - V <sub>HDRV</sub> )		0.95	1.30	
V <sub>OL</sub>	Low-level output voltage, HDRV	(V <sub>HDRV</sub> - V <sub>SW</sub> ), I <sub>HDRV</sub> = 0.01 A		0.06	0.10	V
		(V <sub>HDRV</sub> - V <sub>SW</sub> ), I <sub>HDRV</sub> = 0.1 A		0.65	1.0	
V <sub>OH</sub>	High-level output voltage, LDRV	(V <sub>DBP</sub> - V <sub>LDRV</sub> ), I <sub>LDRV</sub> = -0.01 A		0.65	1.00	V
		(V <sub>DBP</sub> - V <sub>LDRV</sub> ), I <sub>LDRV</sub> = -0.1 A		0.875	1.200	
V <sub>OL</sub>	Low-level output voltage, LDRV	I <sub>LDRV</sub> = 0.01 A		0.03	0.05	V
		I <sub>LDRV</sub> = 0.1 A		0.3	0.5	
<b>ZERO CURRENT DETECTION</b>						
I <sub>ZERO</sub>	Zero current threshold, TPS40070		-5	0	5	mV
<b>BOOST REGULATOR</b>						
V <sub>BOOST</sub>	Output voltage	V <sub>DD</sub> = 12 V	15.2	17.0		V
<b>UVLO</b>						
V <sub>UVLO</sub>	Programmable UVLO threshold voltage	R <sub>KFF</sub> = 90.9 kΩ, turn-on, V <sub>DD</sub> rising	6.2	7.2	8.2	V
	Programmable UVLO hysteresis	R <sub>KFF</sub> = 90.9 kΩ	1.10	1.55	2.00	
	Fixed UVLO threshold voltage	Turn-on, V <sub>DD</sub> rising	4.15	4.30	4.45	
	Fixed UVLO hysteresis		275	365		
<b>POWER GOOD</b>						
V <sub>PG</sub>	Powergood voltage	I <sub>PG</sub> = 1 mA		370	500	mV
V <sub>OH</sub>	High-level output voltage, FB			770		
V <sub>OL</sub>	Low-level output voltage, FB			630		
<b>THERMAL SHUTDOWN</b>						
	Shutdown temperature threshold <sup>(3)</sup>			165		°C
	Hysteresis <sup>(3)</sup>			15		

(3) Ensured by design. Not production tested.

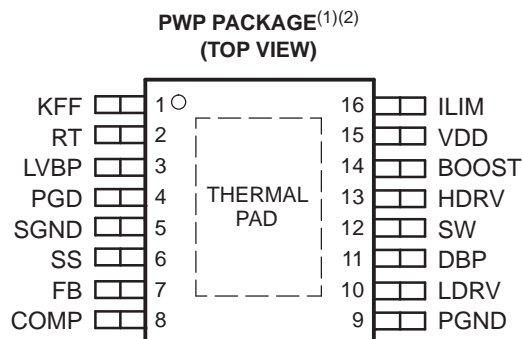

(1) For more information on the PWP package, refer to TI Technical Brief (SLMA002).

(2) PowerPAD™ heat slug must be connected to SGND (pin 5) or electrically isolated from all other pins.

**Table 1. Terminal Functions**

TERMINAL NAME	NO.	I/O	DESCRIPTION
BOOST	14	I	Gate drive voltage for the high-side N-channel MOSFET. The BOOST voltage is 8 V greater than the input voltage. A capacitor should be connected from this pin to the SW pin.
COMP	8	O	Output of the error amplifier, input to the PWM comparator. A feedback network is connected from this pin to the FB pin to compensate the overall loop. The comp pin is internally clamped to 3.4 V.
DBP	11	O	8-V reference used for the gate drive of the N-channel synchronous rectifier. This pin should be bypassed to ground with a 1.0- $\mu$ F ceramic capacitor.
FB	7	I	Inverting input to the error amplifier. In normal operation the voltage on this pin is equal to the internal reference voltage, 0.7 V.
HDRV	13	O	Floating gate drive for the high-side N-channel MOSFET. This pin switches from BOOST (MOSFET on) to SW (MOSFET off).
ILIM	16	I	Short circuit protection programming pin. This pin is used to set the overcurrent threshold. An internal current sink from this pin to ground sets a voltage drop across an external resistor connected from this pin to VDD. The voltage on this pin is compared to the voltage drop ( $V_{VDD} - V_{SW}$ ) across the high side N-channel MOSFET during conduction. Just prior to the beginning of a switching cycle this pin is pulled to approximately VDD/2 and released when SW is within 2 V of VDD or after a timeout (the precondition time) - whichever occurs first. Placing a capacitor across the resistor from ILIM to VDD allows the ILIM threshold to decrease during the switch on time, effectively programming the ILIM blanking time. See applications information.
KFF	1	I	A resistor is connected from this pin to VIN programs the amount of feed-forward voltage. The current fed into this pin is internally divided by 25 and used to control the slope of the PWM ramp and program undervoltage lockout. Nominal voltage at this pin is maintained at 400 mV.
LDRV	10	O	Gate drive for the N-channel synchronous rectifier. This pin switches from DBP (MOSFET on) to ground (MOSFET off). For proper operation, the total gate charge of the MOSFET connected to LDRV should be less than 50nC.
LVBP	3	O	4.2-V reference used for internal device logic only. This pin should be bypassed by a 0.1- $\mu$ F ceramic capacitor. External loads less than 1 mA and electrically quiet may be applied.
PGD	4	O	This is an open drain output that pulls to ground when soft start is active, or when the FB pin is outside a 10% band around VREF.
PGND	9		Power ground reference for the device. There should be a low-impedance path from this pin to the source(s) of the lower MOSFET(s).
RT	2	I	A resistor is connected from this pin to ground to set the internal oscillator and switching frequency.
SGND	5		Signal ground reference for the device.
SS	6	I	Soft-start programming pin. A capacitor connected from this pin to ground programs the soft-start time. The capacitor is charged with an internal current source of 10 $\mu$ A. The resulting voltage ramp on the SS pin is used as a second non-inverting input to the error amplifier. The voltage at this error amplifier input is approximately 1 V less than that on the SS pin. Output voltage regulation is controlled by the SS voltage ramp until the voltage on the SS pin reaches the internal reference voltage of 1 V plus the internal reference voltage of 0.7 V. If SS is below the 1-V offset voltage to the error amplifier. The resulting output voltage is zero. Also provides timing for fault recovery attempts. Maximum recommended capacitor value is 22nF.
SW	12	I	This pin is connected to the switched node of the converter. It is used for short circuit sensing, gate drive timing information and is the return for the high side driver. A 1.5- $\Omega$ resistor is required in series with this pin for protection against substrate current issues.
VDD	15	I	Supply voltage for the device.

FUNCTIONAL BLOCK DIAGRAM

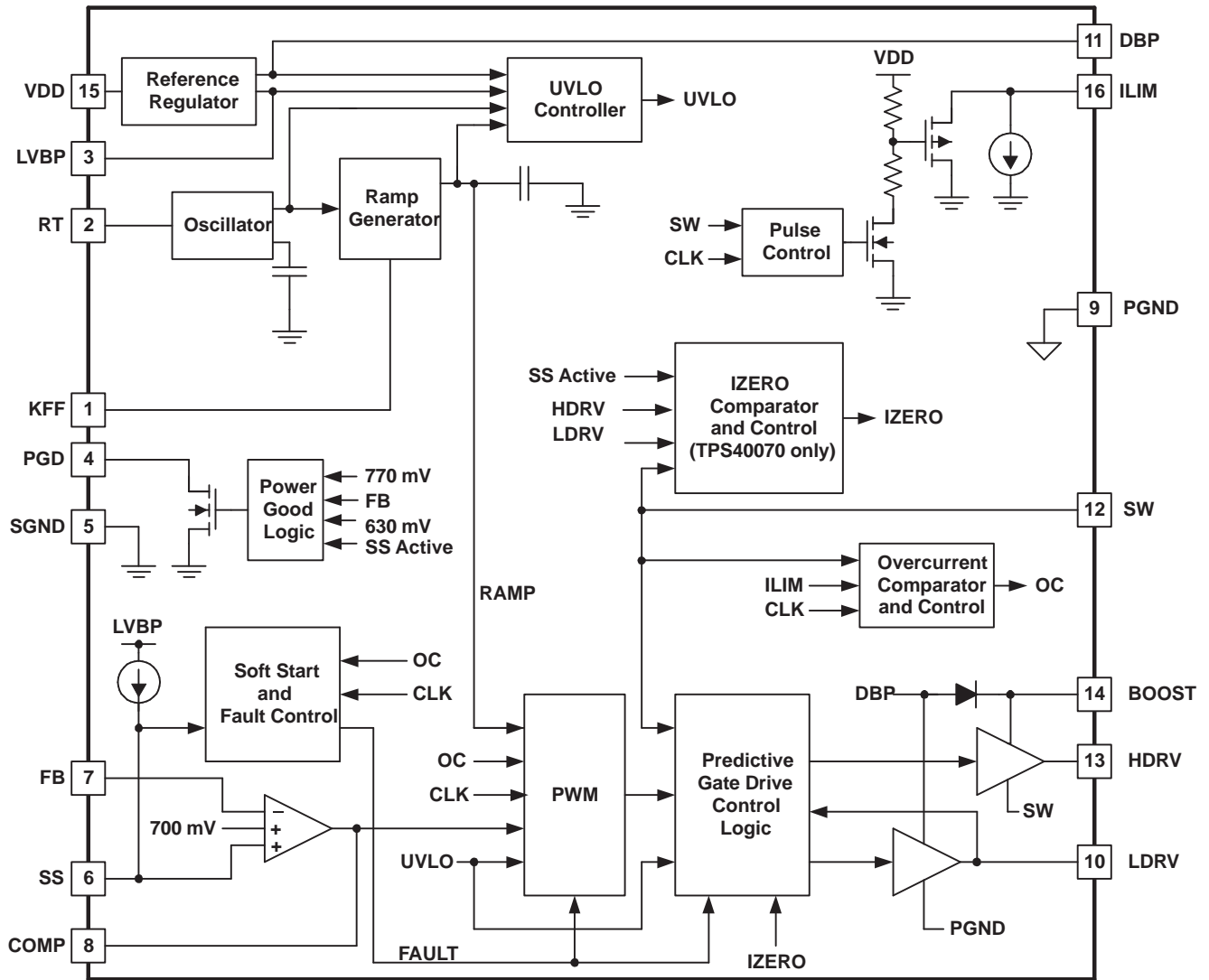

VDG-03171

## APPLICATION INFORMATION

The TPS40070 family of parts allows the user to construct synchronous voltage-mode buck converters with inputs ranging from 4.5 V to 28 V and outputs as low as 700 mV. Predictive gate drive circuitry optimizes switching delays for increased efficiency and improved converter output power capability. Voltage feed-forward is employed to ease loop compensation and provide better line transient response.

A converter based on the TPS40070 operates as a single quadrant (source only) converter at all times. When the rectifier FET is on and the controller senses that current is near zero in the inductor, the rectifier FET is turned off, preventing the buildup of negative or reverse current in the inductor. This feature prevents the converter from pulling energy from its output and forcing that energy onto its input.

Converters based on the TPS40071 operates as a two quadrant converter all the time (source and sink current). This is the controller of choice for most applications.

### MINIMUM PULSE WIDTH

The TPS4007x devices have limitations on the minimum pulse width that can be used to design a converter. Reliable operation is guaranteed for nominal pulse widths of 250 ns and above. This places some restrictions on the conversion ratio that can be achieved at a given switching frequency. [Figure 2](#) shows minimum output voltage for a given input voltage and frequency.

### SLEW RATE LIMIT ON VDD

The regulator that supplies power for the drivers on the TPS40070/1 requires a limited rising slew rate on VDD for proper operation if the input voltage is above 10 V. If the slew rate is too great, this regulator can over shoot and damage to the part can occur. To ensure that the part operates properly, limit the slew rate to no more than 0.12 V/ $\mu$ s as the voltage at VDD crosses 8 V. If necessary, an R-C filter can be used on the VDD pin of the device. Connect the resistor from the VDD pin to the input supply of the converter. Connect the capacitor from the VDD pin to PGND. There should not be excessive (more than a 200-mV) voltage drop across the resistor in normal operation. This places some constraints on the R-C values that can be used. [Figure 1](#) is a schematic fragment that shows the connection of the R-C slew rate limit circuit. [Equation 1](#) and [Equation 2](#) give values for R and C that limits the slew rate in the worst case condition.

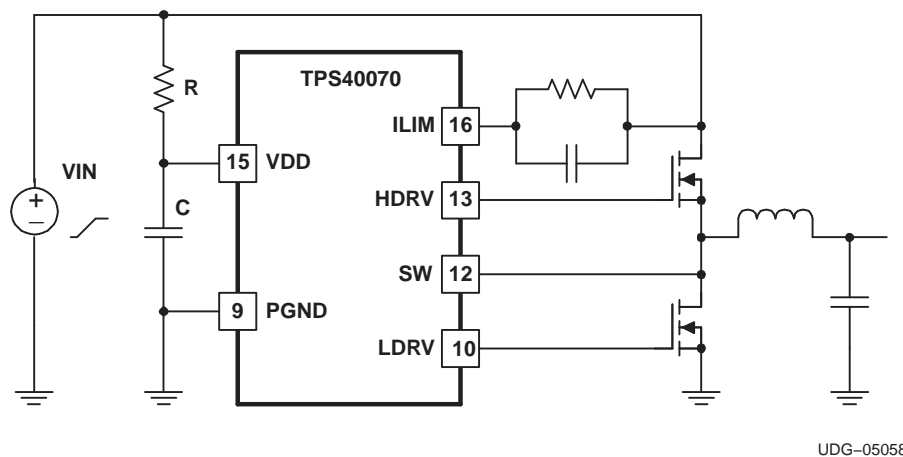

Figure 1. Limiting the Slew Rate

$$C > \frac{V_{IN} - 8\text{ V}}{R \times SR} \tag{1}$$

$$R < \frac{0.2\text{ V}}{f_{SW} \times Q_{g(TOT)} + I_{DD}} \tag{2}$$

where

- $V_{IN}$  is the final value of the input voltage ramp
- $f_{SW}$  is the switching frequency
- $Q_{g(TOT)}$  is the combined total gate charge for both upper and lower MOSFETs (from MOSFET data sheet)
- $I_{DD}$  is the TPS4007x input current (3.5 mA maximum)
- SR is the maximum allowed slew rate [ $12 \times 10^4$ ] (V/s)

### SETTING THE SWITCHING FREQUENCY (PROGRAMMING THE CLOCK OSCILLATOR)

The TPS4007x has independent clock oscillator and PWM ramp generator circuits. The clock oscillator serves as the master clock to the ramp generator circuit. Connecting a single resistor from  $R_T$  to ground sets the switching frequency of the clock oscillator. The clock frequency is related to  $R_T$  by:

$$R_T = \left( \frac{1}{f_{SW}(\text{kHz}) \times 17.82 \times 10^{-6}} - 23 \right) \text{ k}\Omega \tag{3}$$

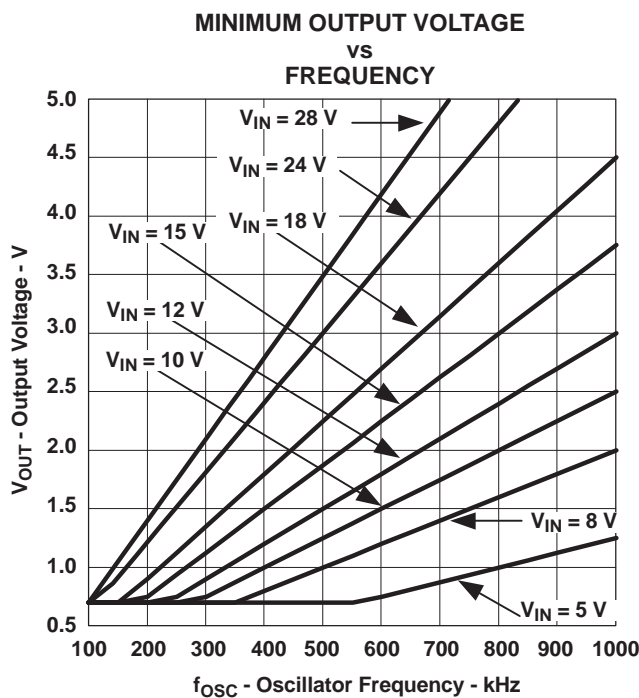

Figure 2.

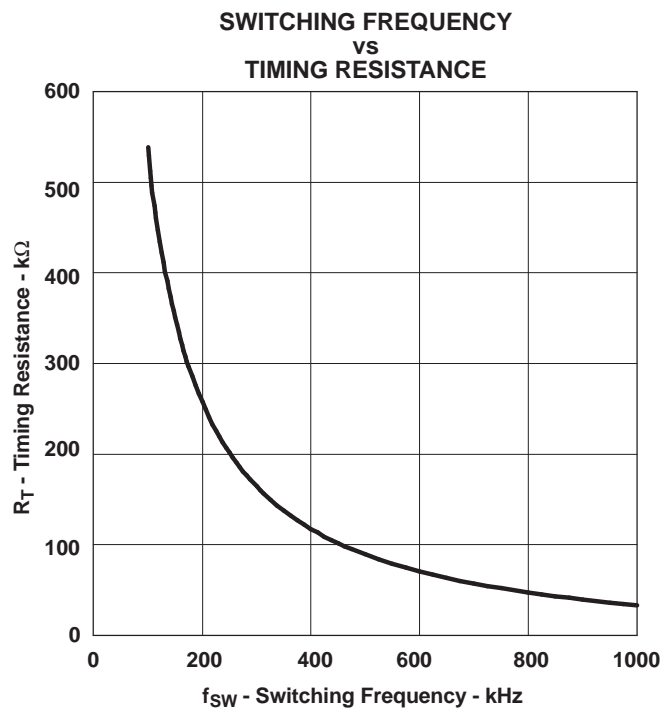

Figure 3.

### PROGRAMMING THE RAMP GENERATOR CIRCUIT AND UVLO

The ramp generator circuit provides the actual ramp used by the PWM comparator. The ramp generator provides voltage feed-forward control by varying the PWM ramp slope with line voltage, while maintaining a constant ramp magnitude. Varying the PWM ramp directly with line voltage provides excellent response to line variations since the PWM does not have to wait for loop delays before changing the duty cycle. (See [Figure 9](#)).

The PWM ramp must reach approximately 1 V in amplitude during a clock cycle, or the PWM is not allowed to start. The PWM ramp time is programmed via a single resistor ( $R_{KFF}$ ) connected from KFF VDD.  $R_{KFF}$ ,  $V_{START}$  and  $R_T$  are related by (approximately):

$$R_{KFF} = 0.131 \times R_T \times V_{UVLO(on)} - 1.61 \times 10^{-3} \times V_{UVLO(on)}^2 + 1.886 \times V_{UVLO} - 1.363 - 0.02 \times R_T - 4.87 \times 10^{-5} \times R_T^2 \quad (4)$$

where

- $R_T$  and  $R_{KFF}$  are in  $k\Omega$
- $V_{UVLO(on)}$  is in V

This yields typical numbers for the programmed startup voltage. The minimum and maximum values may vary up to 15% from this number. Figure 5 through Figure 6 show the typical relationship of  $V_{UVLO(on)}$ ,  $V_{UVLO(off)}$  and  $R_{KFF}$  at three common frequencies.

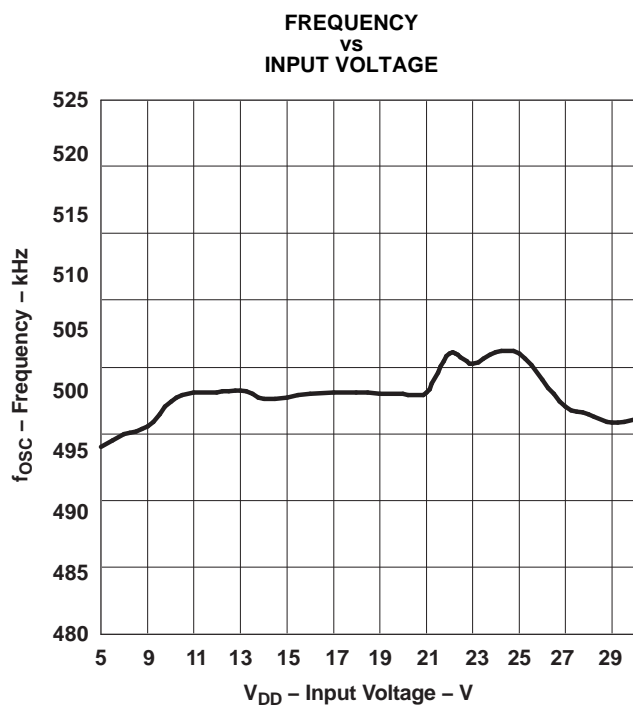

Figure 4.

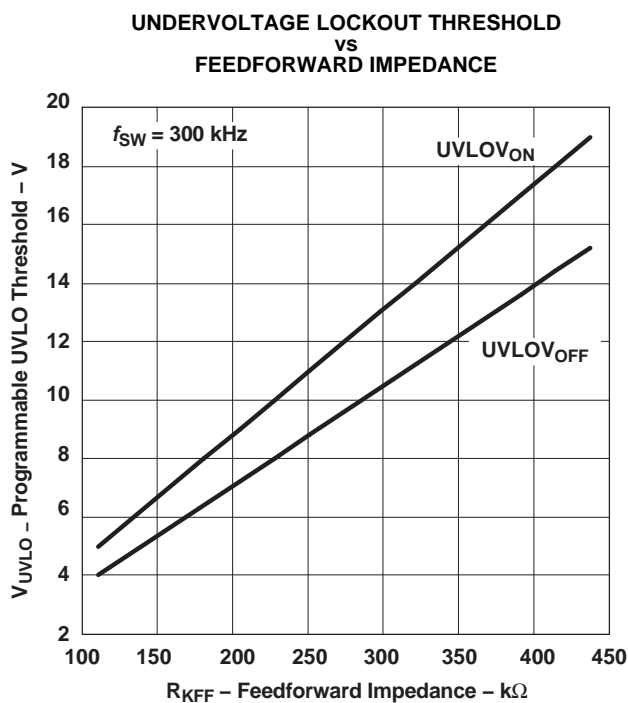

Figure 5.

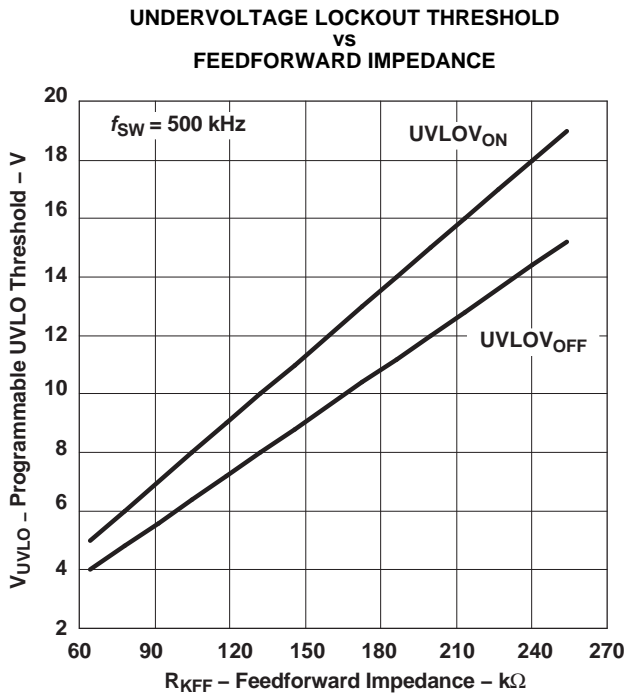

Figure 6.

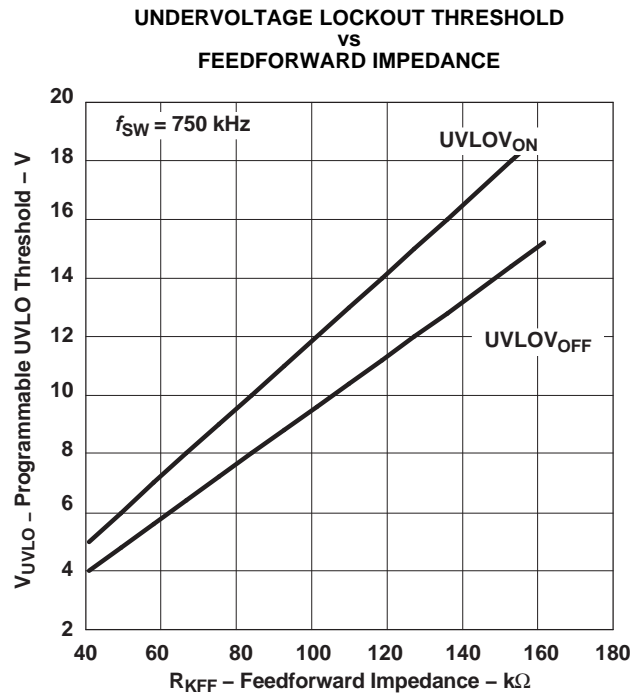

Figure 7.

The programmable UVLO circuit incorporates 20% hysteresis from the start voltage to the shutdown voltage. For example, if the startup voltage is programmed to be 10 V, the controller starts when  $V_{DD}$  reaches 10 V and shuts down when  $V_{DD}$  falls below 8 V. The maximum duty cycle begins to decrease as the input voltage rises to twice the startup voltage. Below this point, the maximum duty cycle is as specified in the electrical table. Note that with this scheme, the theoretical maximum output voltage that the converter can produce is approximately two times the programmed startup voltage. For design, set the programmed startup voltage equal to or greater than the desired output voltage divided by maximum duty cycle (85% for frequencies 500 kHz and below). For example, a 5-V output converter should not have a programmed startup voltage below 5.9 V. Figure 8 shows the theoretical maximum duty cycle (typical) for various programmed startup voltages

At startup, LDRV may pulse high when  $V_{DD}$  is in the range of 1 V to 1.25 V and  $V_{DD}$  is rising extremely slowly. To minimize these effects, the ramp rate of  $V_{DD}$  at startup should be greater than 1 V/ms.

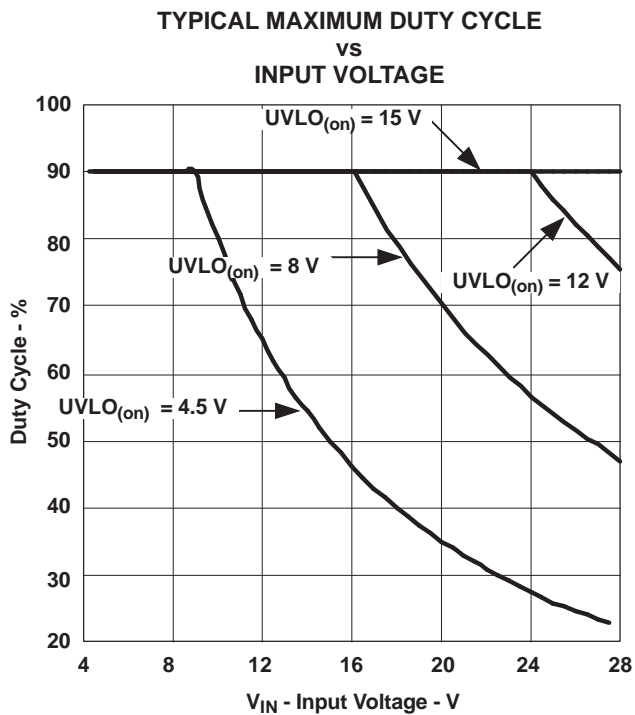
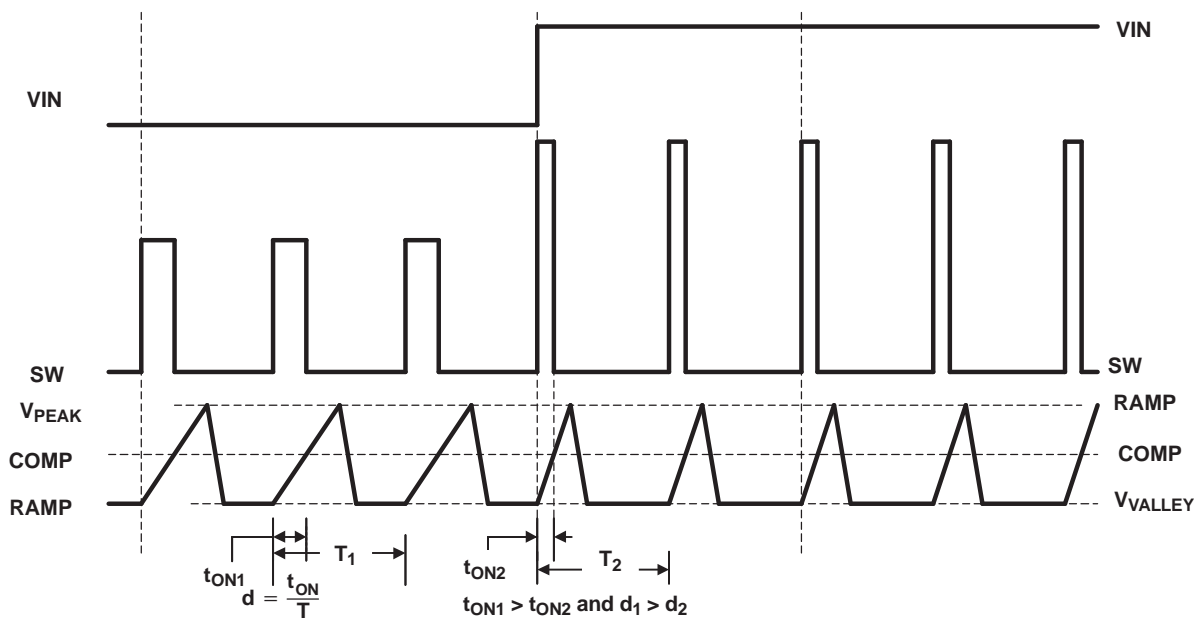

Figure 8.



VDG-03172

Figure 9. Voltage Feed-Forward and PWM Duty Cycle Waveforms

## PROGRAMMING SOFT START

TPS4007x uses a closed-loop approach to ensure a controlled ramp on the output during start-up. Soft-start is programmed by connecting an external capacitor ( $C_{SS}$ ) from the SS pin to GND. This capacitor is charged by a fixed current, generating a ramp signal. The voltage on SS is level shifted down approximately 1 V and fed into a separate non-inverting input to the error amplifier. The loop is closed on the lower of the level shifted SS voltage or the 700-mV internal reference voltage. Once the level shifted SS voltage rises above the internal reference voltage, output voltage regulation is based on the internal reference. To ensure a controlled ramp-up of the output voltage the soft-start time should be greater than the L- $C_{OUT}$  time constant or:

$$t_{START} \geq 2\pi \times \sqrt{L \times C_{OUT}} \quad (5)$$

To ensure correct start up of the converter, the soft-start time is limited and can be calculated using [Equation 6](#).

$$t_{START} \leq \frac{D_{MIN}}{f_{SW} \times 10^{-7}} \text{ ms} \quad (6)$$

where

- $D_{MIN}$  is the minimum operating duty cycle
- $f_{SW}$  is the converter switching frequency

Please note: There is a direct correlation between  $t_{START}$  and the input current required during start-up. The lower  $t_{START}$  is, the higher the input current required during start-up since the output capacitance must be charged faster. For a desired soft-start time, the soft-start capacitance,  $C_{SS}$ , can be found from:

$$C_{SS} = \frac{12 \times 10^{-6} \text{ A}}{0.7 \text{ V}} \times t_{START} \text{ (Farads)} \quad (7)$$

## PROGRAMMING SHORT CIRCUIT PROTECTION

The TPS4007x uses a two-tier approach for short circuit protection. The first tier is a pulse-by-pulse protection scheme. Short circuit protection is implemented on the high-side MOSFET by sensing the voltage drop across the MOSFET when its gate is driven high. The MOSFET voltage is compared to the voltage dropped across a resistor ( $R_{ILIM}$ ) connected from  $V_{DD}$  to the ILIM pin when driven by a constant current. If the voltage drop across the MOSFET exceeds the voltage drop across the ILIM resistor the switching pulse is immediately terminated. The MOSFET remains off until the next switching cycle is initiated. This is illustrated in [Figure 10](#).

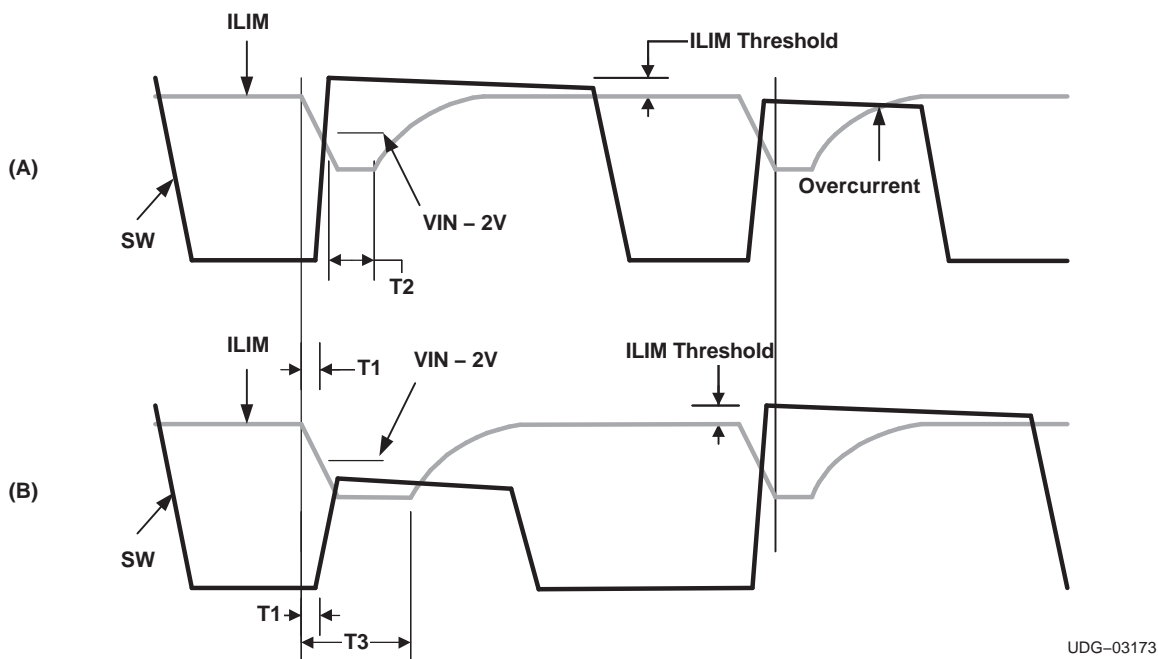

Figure 10. Switching and Current Limit Waveforms and Timing Relationship

In addition, just prior to the high-side MOSFET turning on, the ILIM pin is pulled down to approximately half of VDD. The ILIM pin is allowed to return to its nominal value after one of two events occur. If the SW node rises to within approximately 2 V of VDD, the device allows ILIM to go back to its nominal value. This is illustrated in [Figure 10\(A\)](#). T1 is the delay time from the internal PWM signal being asserted and the rise of SW. This includes a driver delay of 50 ns typical. T2 is the reaction time of the sensing circuit that allows ILIM to start to return to its nominal value, typically 20ns. The second event that can cause ILIM to return to its nominal value is for an internal timeout to expire. This is illustrated in [Figure 10\(B\)](#) as T3. Here SW never rises to VDD-2 V, for whatever reason, and the internal timer times out, releasing the ILIM pin.

Prior to ILIM starting back to its nominal value, overcurrent sensing is not enabled. In normal operation, this ensures that the SW node is at a higher voltage than ILIM when overcurrent sensing starts, avoiding false trips while allowing for a quicker blanking delay than would ordinarily be possible. Placing a capacitor across R<sub>ILIM</sub> sets an exponential approach to the normal voltage at the ILIM pin. This exponential decay of the overcurrent threshold can be used to compensate for ringing on the SW node after its rising edge and to help compensate for slower turn-on FETs. Choosing the proper capacitance requires care. If the capacitance is too large, the voltage at ILIM does not approach the desired overcurrent level quickly enough, resulting in an apparent shift in overcurrent threshold as pulse width changes.

Also, the comparator that uses ILIM and SW to determine if an overcurrent condition exists has a clamp on its SW input. This clamp makes the SW node never appear to fall more than 1.4 V (approximately, could be as much as 2 V at -40C) below VDD. When ILIM is more than 1.4 V below VDD, the overcurrent circuit is effectively disabled. As a general rule, it is best to make the time constant of the R-C at the ILIM pin 0.2 times or less of the nominal pulse width of the converter as shown in see [Equation 13](#).

The second tier protection incorporates a fault counter. The fault counter is incremented on each cycle with an overcurrent pulse and decremented on a clock cycle without an overcurrent pulse. When the counter reaches seven (7) a fault condition is declared by the controller. When this happens, the outputs are placed in a state defined in [Table 2](#). Seven soft-start cycles are initiated (without activity on the HDRV and LDRV outputs) and the PWM is disabled during this period. The counter is decremented on each soft-start cycle. When the counter is decremented to zero the PWM is re-enabled and the controller attempts to restart. If the fault has been removed the output starts up normally. If the output is still present the counter counts seven overcurrent pulses and re-enter the second tier fault mode. Refer to [Figure 11](#) for typical fault protection waveforms.

The minimum short circuit limit setpoint ( $I_{SCP(min)}$ ) depends on  $t_{START}$ ,  $C_{OUT}$ ,  $V_{OUT}$ , ripple current in inductor ( $I_{RIPPLE}$ ) and the load current at turn-on ( $I_{LOAD}$ ).

$$I_{SCP(min)} > \left( \frac{C_{OUT} \times V_{OUT}}{t_{START}} \right) + I_{LOAD} + \left( \frac{I_{RIPPLE}}{2} \right) \quad (8)$$

The short circuit limit programming resistor ( $R_{ILIM}$ ) is calculated from:

$$R_{ILIM} = \frac{100 \times \left( R_{DS(ON)max} \times I_{SCP} + V_{ILIM(ofst)} \right) + 9 \times R_{VDD} \times I_{RVDD} + 4.5 \text{ V}}{109 \times I_{ILIM}} \quad (\Omega) \quad (9)$$

where

- $I_{ILIM}$  is the current into the ILIM pin (110  $\mu$ A typical)
- $V_{ILIM(ofst)}$  is the offset voltage between SW and ILIM pins (-50 mV typical)
- $I_{SCP}$  is the short-circuit protection current
- $R_{DS(ON)max}$  is the drain-to-source resistance of the high-side MOSFET
- $R_{VDD}$  is the slew rate limit resistor if used
- $I_{RVDD}$  is the current through  $R_{VDD}$  and can be calculated using [Equation 10](#).

$$I_{RVDD} = f_{SW} \times Q_{g(TOT)} + I_{DD} \quad (A) \quad (10)$$

where

- $f_{SW}$  is the switching frequency
- $Q_{g(TOT)}$  is the combined total gate charge for both upper and lower MOSFETs (from MOSFET data sheet)
- $I_{DD}$  is the TPS4007x input current (3.5 mA maximum)

To find the range of the overcurrent values use the following equations.

$$I_{SCP(max)} = \frac{1.09 \times I_{ILIM(max)} \times R_{ILIM} - 0.09 \times R_{VDD} \times I_{RVDD} - 0.045 \text{ V} + 75 \text{ mV}}{R_{DS(ON)min}} \quad (A) \quad (11)$$

$$I_{SCP(min)} = \frac{1.09 \times I_{ILIM(min)} \times R_{ILIM} - 0.09 \times R_{VDD} \times I_{RVDD} - 0.045 \text{ V} + 30 \text{ mV}}{R_{DS(ON)max}} \quad (A) \quad (12)$$

The TPS40070/1 provides short circuit protection only. As such, it is recommended that the minimum short circuit protection level be placed at least 20% above the maximum output current required from the converter. The maximum output of the converter should be the steady state maximum output plus any transient specification that may exist.

The ILIM capacitor maximum value can be found from:

$$C_{ILIM(max)} = \frac{V_{OUT} \times 0.2}{V_{IN} \times R_{ILIM} \times f_{SW}} \quad (\text{Farads}) \quad (13)$$

Note that this is a recommended maximum value. If a smaller value can be used, it should be. For most applications, consider using half the maximum value above.

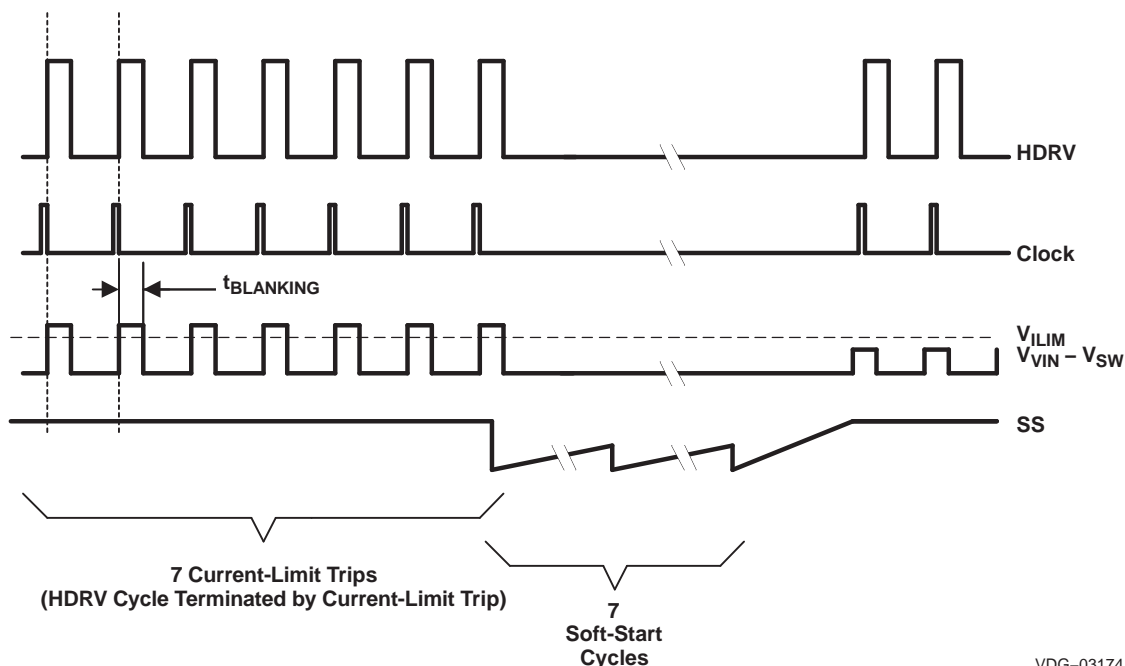

VDG-03174

Figure 11. Typical Fault Protection Waveforms

## LOOP COMPENSATION

Voltage mode buck type converters are typically compensated using Type III networks. Since the TPS4007x uses voltage feedforward control, the gain of the voltage feedforward circuit must be included in the PWM gain. The gain of the voltage feedforward circuit combined with the PWM circuit and power stage for the TPS4007x is:

$$K_{\text{PWM}} \cong V_{\text{UVLO (on)}} \quad (14)$$

The remainder of the loop compensation is performed as in a normal buck converter. Note that the voltage feedforward circuitry removes the input voltage term from the expression for PWM gain. PWM gain is strictly a function of the programmed startup voltage.

## BOOST AND DBP BYPASS CAPACITANCE

The BOOST capacitance provides a local, low-impedance flying source for the high-side driver. The BOOST capacitor should be a good quality, high-frequency capacitor. A capacitor with a minimum value of 100-nF is suggested.

The DBP has to provide energy for both the synchronous MOSFET and the high-side MOSFET (via the BOOST capacitor). The suggested value for this capacitor is 1- $\mu$ F ceramic, minimum.

## INTERNAL REGULATORS

The internal regulators are linear regulators that provide controlled voltages for the drivers and the internal circuitry to operate from. The DBP pin is connected to a nominal 8-V regulator that provides power for the driver circuits to operate from. This regulator has two modes of operation. At  $V_{DD}$  voltages below 8.5 V, the regulator is in a low dropout mode of operation and tries to provide as little impedance as possible from  $V_{DD}$  to DBP. Above 10 V at  $V_{DD}$ , the regulator regulates DBP to 8 V. Between these two voltages, the regulator remains in the state it was in when  $V_{DD}$  entered this region (see Figure 12). Small amounts of current can be drawn from this pin for other circuit functions, as long as power dissipation in the controller device remains at acceptable levels and junction temperature does not exceed 125C.

The LVBP pin is connected to another internal regulator that provides 4.2-V (nom) for the operation of low-voltage circuitry in the controller. This pin can be used for other circuit purposes, but extreme care must be taken to ensure that no extra noise is coupled onto this pin, since controller performance suffers. Current draw is not to exceed 1 mA. See Figure 13 for typical output voltage at this pin.

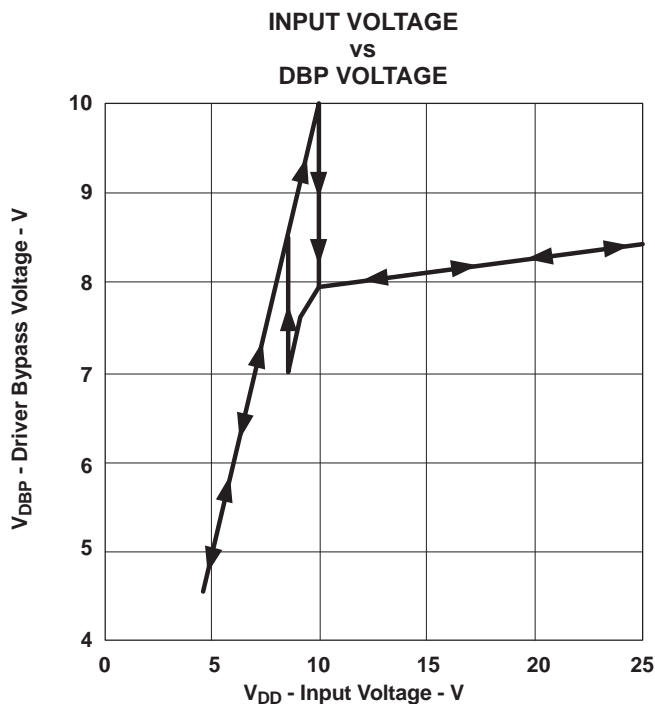

Figure 12.

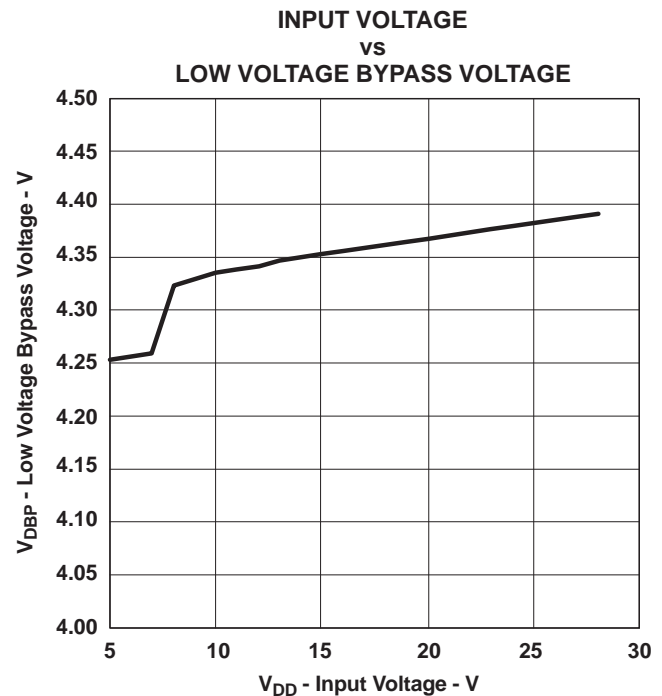

Figure 13.

## TPS4007x POWER DISSIPATION

The power dissipation in the TPS4007x is largely dependent on the MOSFET driver currents and the input voltage. The driver current is proportional to the total gate charge,  $Q_g$ , of the external MOSFETs. Driver power (neglecting external gate resistance) can be calculated from:

$$P_D = Q_g \times V_{DR} \times f_{SW} \quad (\text{Watts/driver}) \quad (15)$$

where

- $V_{DR}$  is the driver output voltage

And the total power dissipation in the TPS4007x, assuming the same MOSFET is selected for both the high-side and synchronous rectifier is described in [Equation 16](#).

$$P_T = \left( \frac{2 \times P_D}{V_{DR}} + I_Q \right) \times V_{IN} \quad (\text{Watts}) \quad (16)$$

or

$$P_T = (2 \times Q_g \times f_{SW} + I_Q) \times V_{IN} \quad (\text{Watts}) \quad (17)$$

where:

- $I_Q$  is the quiescent operating current (neglecting drivers)

The maximum power capability of the TPS4007x PowerPAD package is dependent on the layout as well as air flow. The thermal impedance from junction to air assuming 2-oz. copper trace and thermal pad with solder and no air flow is see the application report titled *PowerPAD Thermally Enhanced Package* (SLMA002) for detailed information on PowerPAD package mounting and usage.

$$\theta_{JA} = 36.51^\circ\text{C/W} \quad (18)$$

The maximum allowable package power dissipation is related to ambient temperature by [Equation 19](#).

$$P_T = \frac{T_J - T_A}{\theta_{JA}} \quad (\text{Watts}) \quad (19)$$

Substituting [Equation 19](#) into [Equation 18](#) and solving for  $f_{SW}$  yields the maximum operating frequency for the TPS4007x. The result is described in [Equation 20](#).

$$f_{SW} = \frac{\left( \left[ \frac{(T_J - T_A)}{(\theta_{JA} \times V_{DD})} \right] - I_Q \right)}{(2 \times Q_g)} \quad (\text{Hz}) \quad (20)$$

## BOOST DIODE

The TPS4007x series has internal diodes to charge the boost capacitor connected from SW to BOOST. The drop across this diode is rather large at 1.4-V nominal at room temperature. If this drop is too large for a particular application, an external diode may be connected from DBP (anode) to BOOST (cathode). This provides significantly improved gate drive for the high side FET, especially at lower input voltages.

## LOW VOLTAGE OPERATION

If the programmable UVLO is set to less than 6.5 V nominal, connect a 330-k $\Omega$  resistor across the soft-start capacitor. This eliminates a race condition inside the device that can lead to an output voltage overshoot on power down of the part. If operation is expected below -10°C ambient temperature and at less than 5-V input, it is recommended that a diode be connected from LVBP to DBP. (See [Figure 16](#)).

## GROUNDING AND BOARD LAYOUT

The TPS4007x provides separate signal ground (SGND) and power ground (PGND) pins. Care should be given to proper separation of the circuit grounds. Each ground should consist of a plane to minimize its impedance if possible. The high power *noisy* circuits such as the output, synchronous rectifier, MOSFET driver decoupling capacitor (DBP), and the input capacitor should be connected to PGND plane.

Sensitive nodes such as the FB resistor divider and RT should be connected to the SGND plane. The SGND plane should only make a single point connection to the PGND plane. It is suggested that the SGND pin be tied to the copper area for the PowerPAD underneath the chip. Tie the PGND to the PowerPAD copper area as well and make the connection to the power circuit ground from the PGND pin. Reference the output voltage divider to the SGND pin.

Component placement should ensure that bypass capacitors (LVPB and DBP) are located as close as possible to their respective power and ground pins. Also, sensitive circuits such as FB, RT and ILIM should not be located near high dv/dt nodes such as HDRV, LDRV, BOOST, and the switch node (SW). Failure to follow careful layout practices results in sub-optimal operation. More detailed information can be found in the TPS40071EVM User's Guide (SLUU180).

### **Output Ripple Consideration**

In addition to the typical output ripple associated with switching converters, which can vary from 5 mV to 150 mV, the TPS40070/1 exhibits a low-frequency ripple from 5 mV to 50 mV. The ripple, a consequence of the charge pump in the driver supply regulator, is well bounded under changes in line, load, and temperature. The ripple frequency does vary with the converter switching frequency and can vary from 10 kHz to 60 kHz.

### SYNCHRONOUS RECTIFIER CONTROL

Depending on which device is used the synchronous rectifier is controlled in slightly different ways. Table 2 describes the differences. For proper operation, the total gate charge of the MOSFET connected to LDRV should be less than 50 nC.

Table 2. Synchronous Rectifier MOSFET States

DEVICE	SYNCHRONOUS RECTIFIER OPERATION DURING			
	SOFT-START	NORMAL	FAULT	OVERVOLTAGE
TPS40070	Turns OFF when I <sub>ZERO</sub> detected or start of next cycle	Turns Off when I <sub>ZERO</sub> detected or start of next cycle	OFF	Turns OFF when I <sub>ZERO</sub> detected or start of next cycle
TPS40071	Turns OFF only at start of next cycle	Turns OFF only at start of next cycle	ON	Turns OFF only at start of next cycle, if duty cycle is > 0

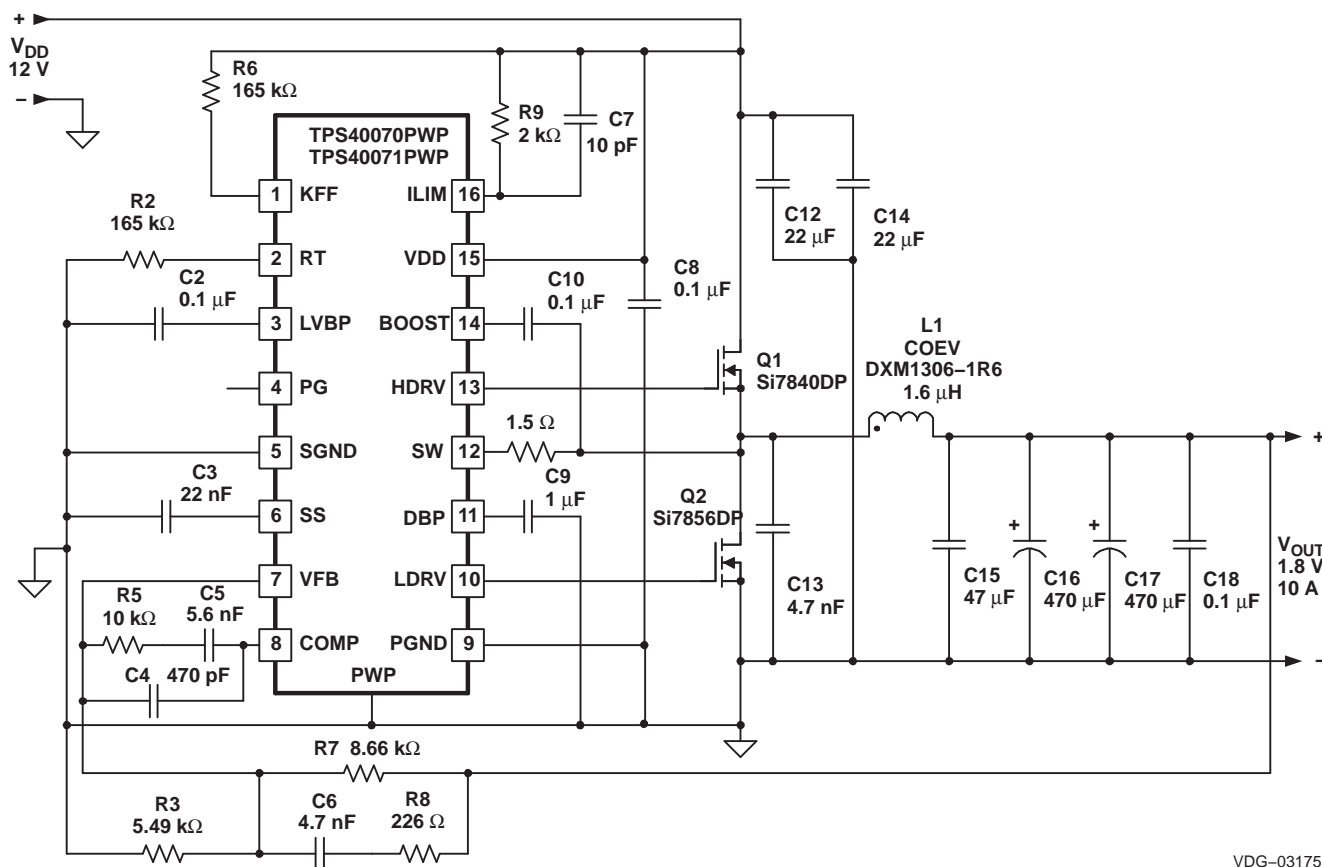
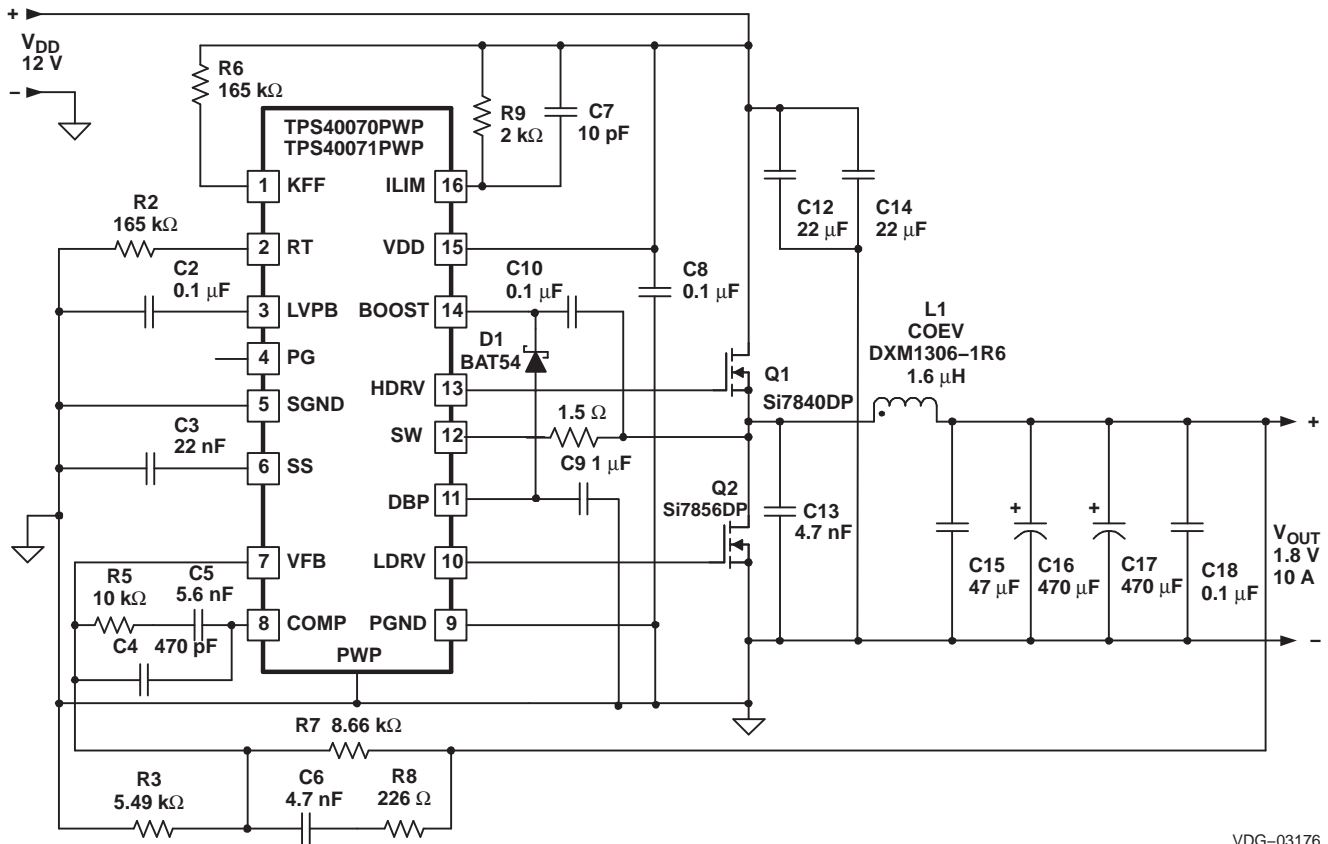

Figure 14. 300 kHz, 12 V to 1.8 V

VDG-03175



VDG-03176

Figure 15. 300 kHz, 12 V to 1.8 V with Improved High-Side Gate Drive

See Application Information section *Boost Diodes*.

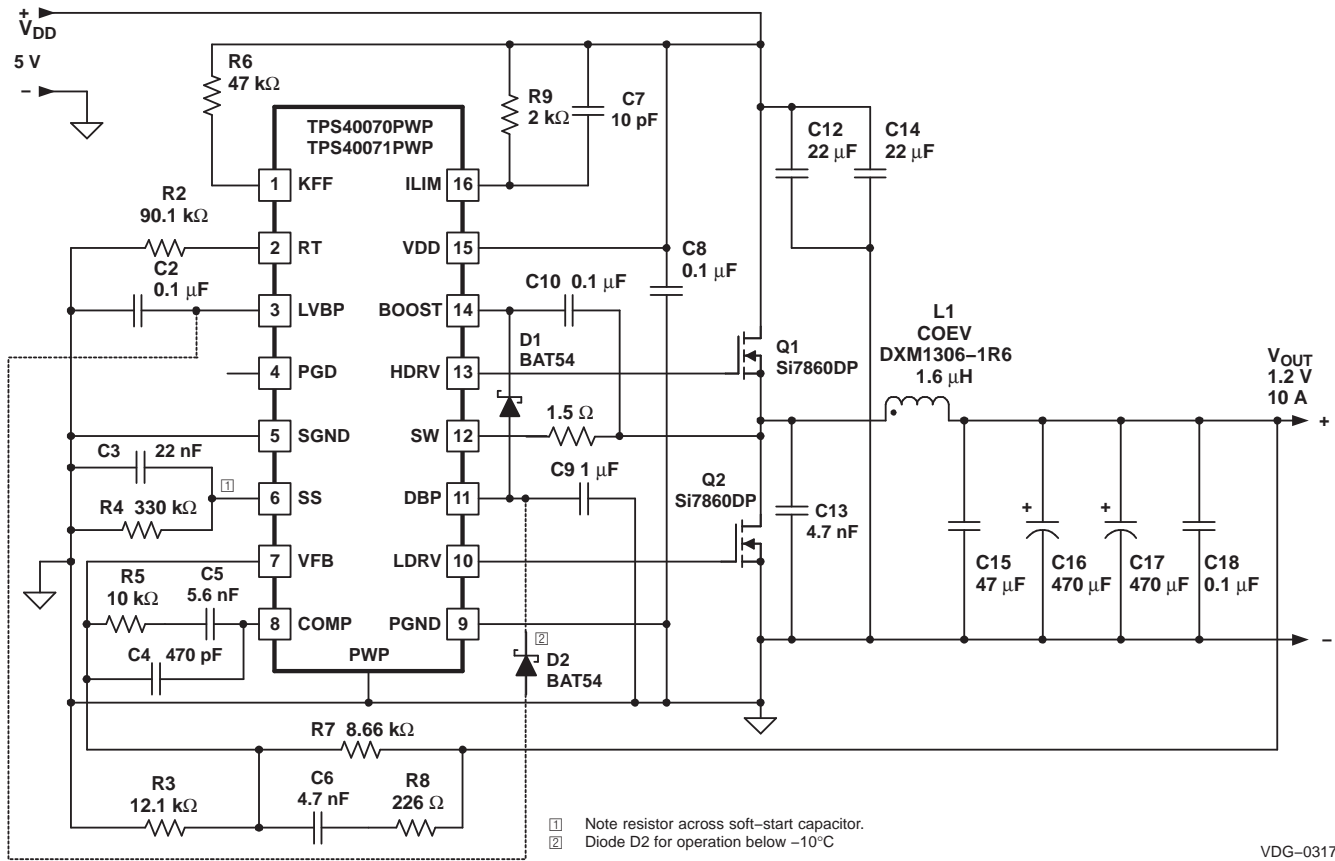

Figure 16. 500 kHz, 5 V to 1.2 V with Improved High-Side Gate Drive

See Application Information section *Boost Diodes*.

**PACKAGING INFORMATION**

Orderable Device	Status <sup>(1)</sup>	Package Type	Package Drawing	Pins	Package Qty	Eco Plan <sup>(2)</sup>	Lead/Ball Finish	MSL Peak Temp <sup>(3)</sup>
TPS40070PWP	NRND	HTSSOP	PWP	16	90	Green (RoHS & no Sb/Br)	CU NIPDAU	Level-2-260C-1 YEAR
TPS40070PWPG4	NRND	HTSSOP	PWP	16	90	Green (RoHS & no Sb/Br)	CU NIPDAU	Level-2-260C-1 YEAR
TPS40070PWPR	NRND	HTSSOP	PWP	16	2000	Green (RoHS & no Sb/Br)	CU NIPDAU	Level-2-260C-1 YEAR
TPS40070PWPRG4	NRND	HTSSOP	PWP	16	2000	Green (RoHS & no Sb/Br)	CU NIPDAU	Level-2-260C-1 YEAR
TPS40071PWP	NRND	HTSSOP	PWP	16	90	Green (RoHS & no Sb/Br)	CU NIPDAU	Level-2-260C-1 YEAR
TPS40071PWPG4	NRND	HTSSOP	PWP	16	90	Green (RoHS & no Sb/Br)	CU NIPDAU	Level-2-260C-1 YEAR
TPS40071PWPR	NRND	HTSSOP	PWP	16	2000	Green (RoHS & no Sb/Br)	CU NIPDAU	Level-2-260C-1 YEAR
TPS40071PWPRG4	NRND	HTSSOP	PWP	16	2000	Green (RoHS & no Sb/Br)	CU NIPDAU	Level-2-260C-1 YEAR

<sup>(1)</sup> The marketing status values are defined as follows:

**ACTIVE:** Product device recommended for new designs.

**LIFEBUY:** TI has announced that the device will be discontinued, and a lifetime-buy period is in effect.

**NRND:** Not recommended for new designs. Device is in production to support existing customers, but TI does not recommend using this part in a new design.

**PREVIEW:** Device has been announced but is not in production. Samples may or may not be available.

**OBSELETE:** TI has discontinued the production of the device.

<sup>(2)</sup> Eco Plan - The planned eco-friendly classification: Pb-Free (RoHS), Pb-Free (RoHS Exempt), or Green (RoHS & no Sb/Br) - please check <http://www.ti.com/productcontent> for the latest availability information and additional product content details.

**TBD:** The Pb-Free/Green conversion plan has not been defined.

**Pb-Free (RoHS):** TI's terms "Lead-Free" or "Pb-Free" mean semiconductor products that are compatible with the current RoHS requirements for all 6 substances, including the requirement that lead not exceed 0.1% by weight in homogeneous materials. Where designed to be soldered at high temperatures, TI Pb-Free products are suitable for use in specified lead-free processes.

**Pb-Free (RoHS Exempt):** This component has a RoHS exemption for either 1) lead-based flip-chip solder bumps used between the die and package, or 2) lead-based die adhesive used between the die and leadframe. The component is otherwise considered Pb-Free (RoHS compatible) as defined above.

**Green (RoHS & no Sb/Br):** TI defines "Green" to mean Pb-Free (RoHS compatible), and free of Bromine (Br) and Antimony (Sb) based flame retardants (Br or Sb do not exceed 0.1% by weight in homogeneous material)

<sup>(3)</sup> MSL, Peak Temp. -- The Moisture Sensitivity Level rating according to the JEDEC industry standard classifications, and peak solder temperature.

**Important Information and Disclaimer:**The information provided on this page represents TI's knowledge and belief as of the date that it is provided. TI bases its knowledge and belief on information provided by third parties, and makes no representation or warranty as to the accuracy of such information. Efforts are underway to better integrate information from third parties. TI has taken and continues to take reasonable steps to provide representative and accurate information but may not have conducted destructive testing or chemical analysis on incoming materials and chemicals. TI and TI suppliers consider certain information to be proprietary, and thus CAS numbers and other limited information may not be available for release.

In no event shall TI's liability arising out of such information exceed the total purchase price of the TI part(s) at issue in this document sold by TI to Customer on an annual basis.

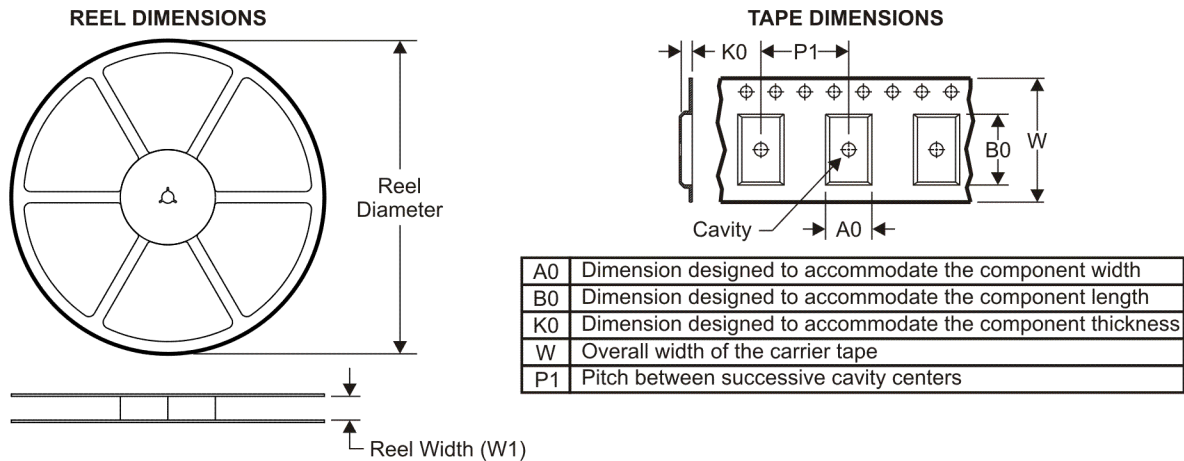
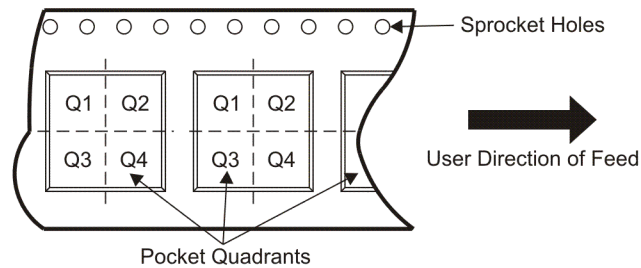
**TAPE AND REEL INFORMATION**

**QUADRANT ASSIGNMENTS FOR PIN 1 ORIENTATION IN TAPE**

\*All dimensions are nominal

Device	Package Type	Package Drawing	Pins	SPQ	Reel Diameter (mm)	Reel Width W1 (mm)	A0 (mm)	B0 (mm)	K0 (mm)	P1 (mm)	W (mm)	Pin1 Quadrant
TPS40070PWPR	HTSSOP	PWP	16	2000	330.0	12.4	6.9	5.6	1.6	8.0	12.0	Q1
TPS40071PWPR	HTSSOP	PWP	16	2000	330.0	12.4	6.9	5.6	1.6	8.0	12.0	Q1

**TAPE AND REEL BOX DIMENSIONS**

\*All dimensions are nominal

Device	Package Type	Package Drawing	Pins	SPQ	Length (mm)	Width (mm)	Height (mm)
TPS40070PWPR	HTSSOP	PWP	16	2000	346.0	346.0	29.0
TPS40071PWPR	HTSSOP	PWP	16	2000	346.0	346.0	29.0

PWP (R-PDSO-G16)

PowerPAD™ PLASTIC SMALL OUTLINE

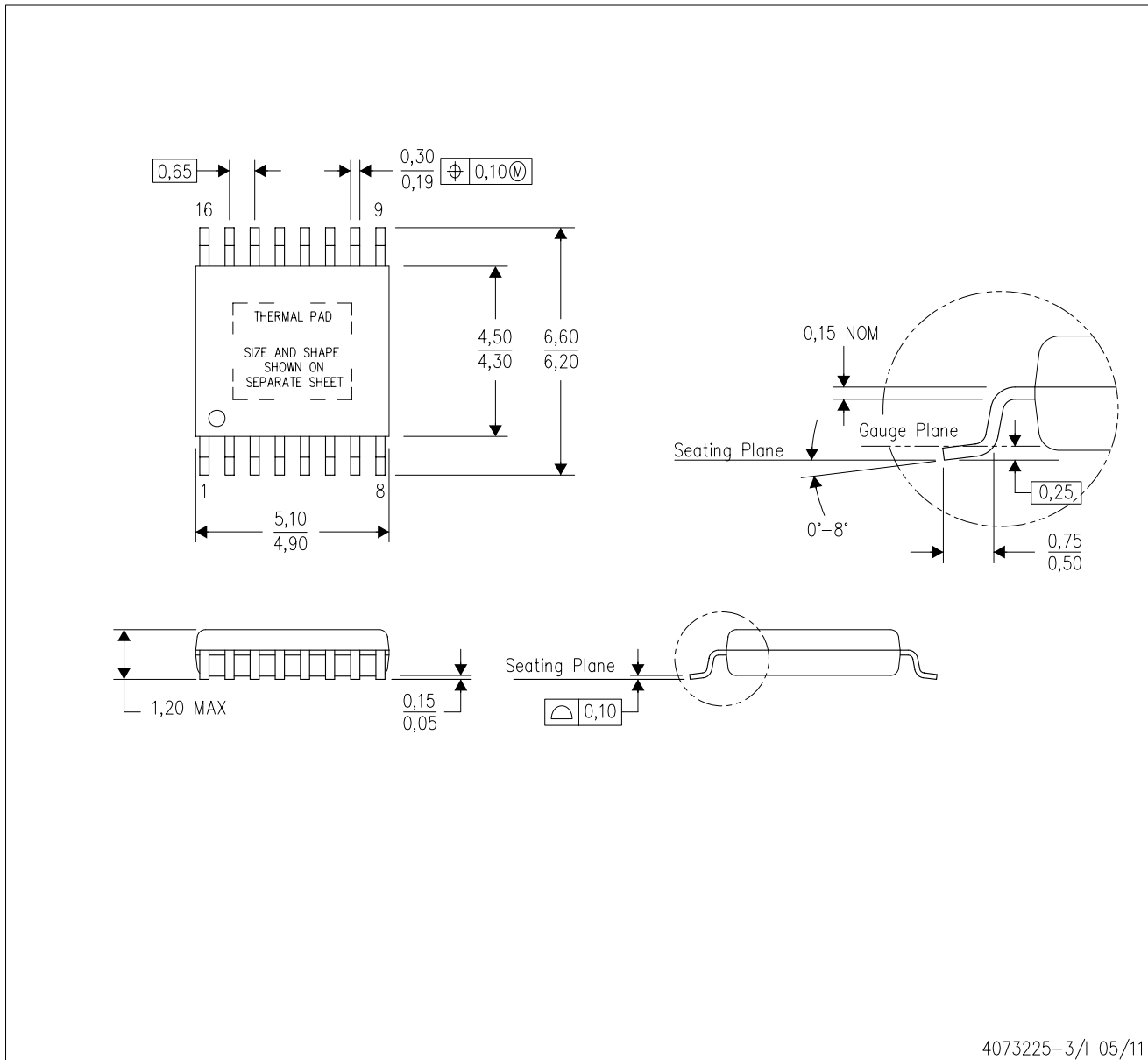

4073225-3/1 05/11

- NOTES:
- All linear dimensions are in millimeters.
  - This drawing is subject to change without notice.
  - Body dimensions do not include mold flash or protrusions. Mold flash and protrusion shall not exceed 0.15 per side.
  - This package is designed to be soldered to a thermal pad on the board. Refer to Technical Brief, PowerPad Thermally Enhanced Package, Texas Instruments Literature No. SLMA002 for information regarding recommended board layout. This document is available at [www.ti.com](http://www.ti.com) <<http://www.ti.com>>.
  - See the additional figure in the Product Data Sheet for details regarding the exposed thermal pad features and dimensions.
  - Falls within JEDEC MO-153

PowerPAD is a trademark of Texas Instruments.

## THERMAL PAD MECHANICAL DATA

### PWP (R-PDSO-G16) PowerPAD™ SMALL PLASTIC OUTLINE

#### THERMAL INFORMATION

This PowerPAD™ package incorporates an exposed thermal pad that is designed to be attached to a printed circuit board (PCB). The thermal pad must be soldered directly to the PCB. After soldering, the PCB can be used as a heatsink. In addition, through the use of thermal vias, the thermal pad can be attached directly to the appropriate copper plane shown in the electrical schematic for the device, or alternatively, can be attached to a special heatsink structure designed into the PCB. This design optimizes the heat transfer from the integrated circuit (IC).

For additional information on the PowerPAD package and how to take advantage of its heat dissipating abilities, refer to Technical Brief, PowerPAD Thermally Enhanced Package, Texas Instruments Literature No. SLMA002 and Application Brief, PowerPAD Made Easy, Texas Instruments Literature No. SLMA004. Both documents are available at [www.ti.com](http://www.ti.com).

The exposed thermal pad dimensions for this package are shown in the following illustration.

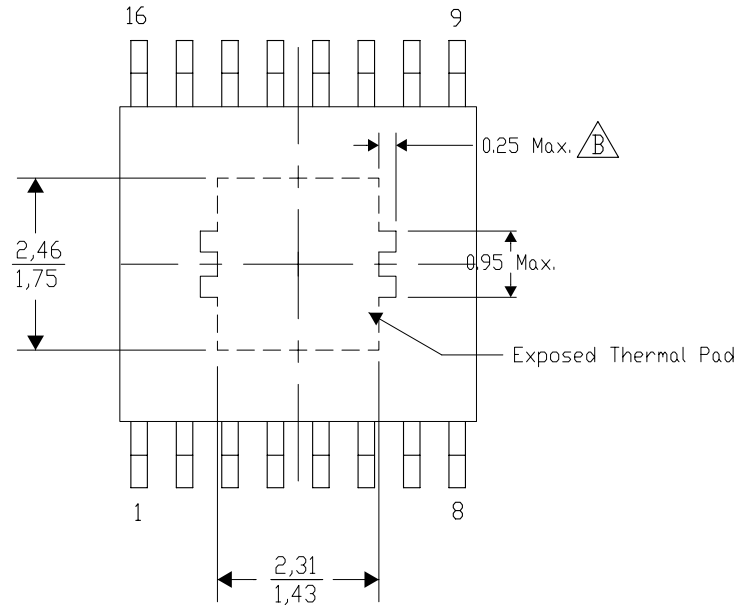

Top View

Exposed Thermal Pad Dimensions

4206332-3/W 05/11

NOTE: A. All linear dimensions are in millimeters

$\triangle B$  Exposed tie strap features may not be present.

PowerPAD is a trademark of Texas Instruments

PWP (R-PDSO-G16)

PowerPAD™ PLASTIC SMALL OUTLINE

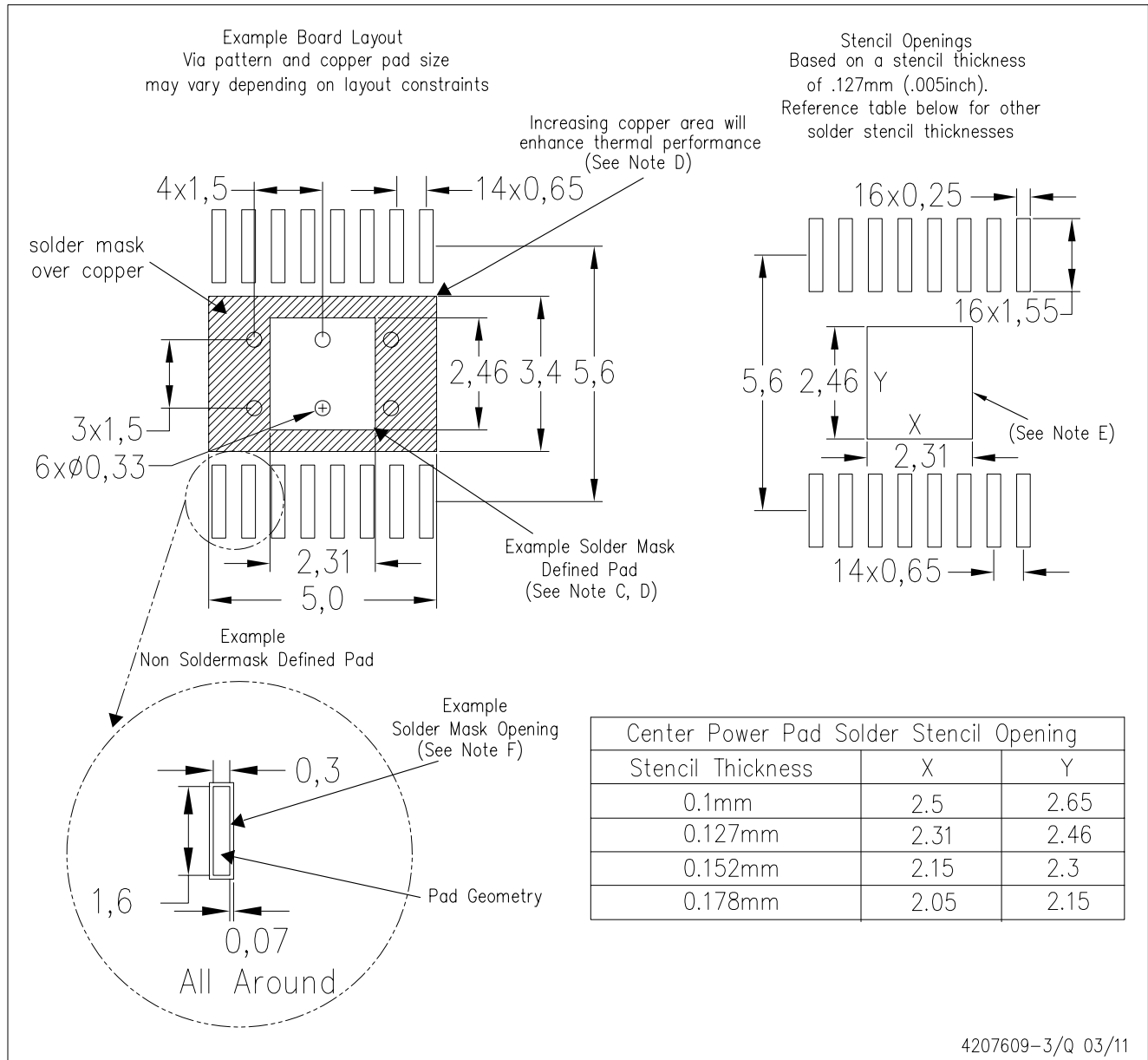

- NOTES:
- A. All linear dimensions are in millimeters.
  - B. This drawing is subject to change without notice.
  - C. Customers should place a note on the circuit board fabrication drawing not to alter the center solder mask defined pad.
  - D. This package is designed to be soldered to a thermal pad on the board. Refer to Technical Brief, PowerPad Thermally Enhanced Package, Texas Instruments Literature No. SLMA002, SLMA004, and also the Product Data Sheets for specific thermal information, via requirements, and recommended board layout. These documents are available at [www.ti.com](http://www.ti.com) <<http://www.ti.com>>. Publication IPC-7351 is recommended for alternate designs.
  - E. Laser cutting apertures with trapezoidal walls and also rounding corners will offer better paste release. Customers should contact their board assembly site for stencil design recommendations. Example stencil design based on a 50% volumetric metal load solder paste. Refer to IPC-7525 for other stencil recommendations.
  - F. Customers should contact their board fabrication site for solder mask tolerances between and around signal pads.

PowerPAD is a trademark of Texas Instruments.

## IMPORTANT NOTICE

Texas Instruments Incorporated and its subsidiaries (TI) reserve the right to make corrections, modifications, enhancements, improvements, and other changes to its products and services at any time and to discontinue any product or service without notice. Customers should obtain the latest relevant information before placing orders and should verify that such information is current and complete. All products are sold subject to TI's terms and conditions of sale supplied at the time of order acknowledgment.

TI warrants performance of its hardware products to the specifications applicable at the time of sale in accordance with TI's standard warranty. Testing and other quality control techniques are used to the extent TI deems necessary to support this warranty. Except where mandated by government requirements, testing of all parameters of each product is not necessarily performed.

TI assumes no liability for applications assistance or customer product design. Customers are responsible for their products and applications using TI components. To minimize the risks associated with customer products and applications, customers should provide adequate design and operating safeguards.

TI does not warrant or represent that any license, either express or implied, is granted under any TI patent right, copyright, mask work right, or other TI intellectual property right relating to any combination, machine, or process in which TI products or services are used. Information published by TI regarding third-party products or services does not constitute a license from TI to use such products or services or a warranty or endorsement thereof. Use of such information may require a license from a third party under the patents or other intellectual property of the third party, or a license from TI under the patents or other intellectual property of TI.

Reproduction of TI information in TI data books or data sheets is permissible only if reproduction is without alteration and is accompanied by all associated warranties, conditions, limitations, and notices. Reproduction of this information with alteration is an unfair and deceptive business practice. TI is not responsible or liable for such altered documentation. Information of third parties may be subject to additional restrictions.

Resale of TI products or services with statements different from or beyond the parameters stated by TI for that product or service voids all express and any implied warranties for the associated TI product or service and is an unfair and deceptive business practice. TI is not responsible or liable for any such statements.

TI products are not authorized for use in safety-critical applications (such as life support) where a failure of the TI product would reasonably be expected to cause severe personal injury or death, unless officers of the parties have executed an agreement specifically governing such use. Buyers represent that they have all necessary expertise in the safety and regulatory ramifications of their applications, and acknowledge and agree that they are solely responsible for all legal, regulatory and safety-related requirements concerning their products and any use of TI products in such safety-critical applications, notwithstanding any applications-related information or support that may be provided by TI. Further, Buyers must fully indemnify TI and its representatives against any damages arising out of the use of TI products in such safety-critical applications.

TI products are neither designed nor intended for use in military/aerospace applications or environments unless the TI products are specifically designated by TI as military-grade or "enhanced plastic." Only products designated by TI as military-grade meet military specifications. Buyers acknowledge and agree that any such use of TI products which TI has not designated as military-grade is solely at the Buyer's risk, and that they are solely responsible for compliance with all legal and regulatory requirements in connection with such use.

TI products are neither designed nor intended for use in automotive applications or environments unless the specific TI products are designated by TI as compliant with ISO/TS 16949 requirements. Buyers acknowledge and agree that, if they use any non-designated products in automotive applications, TI will not be responsible for any failure to meet such requirements.

Following are URLs where you can obtain information on other Texas Instruments products and application solutions:

### Products

Audio	<a href="http://www.ti.com/audio">www.ti.com/audio</a>
Amplifiers	<a href="http://amplifier.ti.com">amplifier.ti.com</a>
Data Converters	<a href="http://dataconverter.ti.com">dataconverter.ti.com</a>
DLP® Products	<a href="http://www.dlp.com">www.dlp.com</a>
DSP	<a href="http://dsp.ti.com">dsp.ti.com</a>
Clocks and Timers	<a href="http://www.ti.com/clocks">www.ti.com/clocks</a>
Interface	<a href="http://interface.ti.com">interface.ti.com</a>
Logic	<a href="http://logic.ti.com">logic.ti.com</a>
Power Mgmt	<a href="http://power.ti.com">power.ti.com</a>
Microcontrollers	<a href="http://microcontroller.ti.com">microcontroller.ti.com</a>
RFID	<a href="http://www.ti-rfid.com">www.ti-rfid.com</a>
RF/IF and ZigBee® Solutions	<a href="http://www.ti.com/lprf">www.ti.com/lprf</a>

### Applications

Communications and Telecom	<a href="http://www.ti.com/communications">www.ti.com/communications</a>
Computers and Peripherals	<a href="http://www.ti.com/computers">www.ti.com/computers</a>
Consumer Electronics	<a href="http://www.ti.com/consumer-apps">www.ti.com/consumer-apps</a>
Energy and Lighting	<a href="http://www.ti.com/energy">www.ti.com/energy</a>
Industrial	<a href="http://www.ti.com/industrial">www.ti.com/industrial</a>
Medical	<a href="http://www.ti.com/medical">www.ti.com/medical</a>
Security	<a href="http://www.ti.com/security">www.ti.com/security</a>
Space, Avionics and Defense	<a href="http://www.ti.com/space-avionics-defense">www.ti.com/space-avionics-defense</a>
Transportation and Automotive	<a href="http://www.ti.com/automotive">www.ti.com/automotive</a>
Video and Imaging	<a href="http://www.ti.com/video">www.ti.com/video</a>
Wireless	<a href="http://www.ti.com/wireless-apps">www.ti.com/wireless-apps</a>

TI E2E Community Home Page

[e2e.ti.com](http://e2e.ti.com)

Mailing Address: Texas Instruments, Post Office Box 655303, Dallas, Texas 75265  
Copyright © 2011, Texas Instruments Incorporated