

Distributed by:

**JAMECO**<sup>®</sup>  
ELECTRONICS

**www.Jameco.com ♦ 1-800-831-4242**

The content and copyrights of the attached  
material are the property of its owner.

Jameco Part Number 762662

## NanoPower Supervisory Circuits

### FEATURES

- Supply Current: 220 nA (typical)
- Precision Supply Voltage Supervision Range: 1.8 V, 2.5 V, 3.0 V, and 3.3 V
- Power-On Reset Generator With Selectable Delay Time: 10 ms or 200 ms
- Push/Pull  $\overline{\text{RESET}}$  Output (TPS3836),  $\overline{\text{RESET}}$  Output (TPS3837), or Open-Drain  $\overline{\text{RESET}}$  Output (TPS3838)
- Manual Reset
- SOT23-5 Package
- Temperature Range:  $-40^{\circ}\text{C}$  to  $+85^{\circ}\text{C}$

### APPLICATIONS

- Applications Using Low-Power DSPs, Microcontrollers, or Microprocessors
- Portable- and Battery-Powered Equipment
- Intelligent Instruments
- Wireless Communication Systems
- Notebook Computers
- Automotive Systems
- Applications Using the MSP430

### DESCRIPTION

The TPS3836, TPS3837, and TPS3838 families of supervisory circuits provide circuit initialization and timing supervision, primarily for DSP and processor-based systems.

During power-on,  $\overline{\text{RESET}}$  is asserted when the supply voltage  $V_{\text{DD}}$  becomes higher than 1.1 V. Thereafter, the supervisory circuit monitors  $V_{\text{DD}}$  and keeps the  $\overline{\text{RESET}}$  output active as long as  $V_{\text{DD}}$  remains below the threshold voltage of  $V_{\text{IT}}$ . An internal timer delays the return of the output to the inactive state (high) to ensure proper system reset. The delay time starts after  $V_{\text{DD}}$  has risen above the threshold voltage  $V_{\text{IT}}$ .

When CT is connected to GND, a fixed delay time of typical 10 ms is asserted. When connected to  $V_{\text{DD}}$ , the delay time is typically 200 ms. When the supply voltage drops below the threshold voltage  $V_{\text{IT}}$ , the output becomes active (low) again. All the devices of this family have a fixed-sense threshold voltage ( $V_{\text{IT}}$ ) set by an internal voltage divider.

The TPS3836 has an active-low, push-pull  $\overline{\text{RESET}}$  output. The TPS3837 has an active-high, push-pull  $\overline{\text{RESET}}$ , and the TPS3838 integrates an active-low, open-drain  $\overline{\text{RESET}}$  output. The product spectrum is designed for supply voltages of 1.8 V, 2.5 V, 3.0 V, and 3.3 V. The circuits are available in a SOT23-5 package. The TPS3836, TPS3837, and TPS3838 families are characterized for operation over a temperature range of  $-40^{\circ}\text{C}$  to  $+85^{\circ}\text{C}$ .

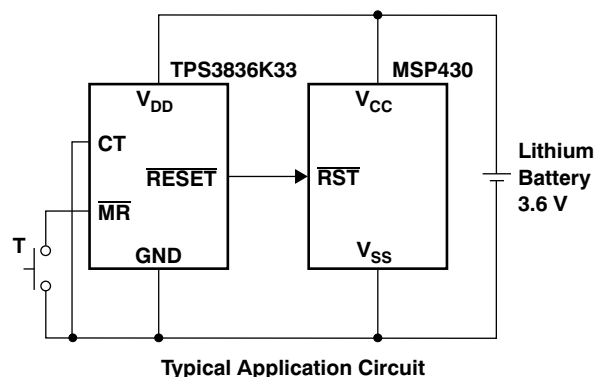
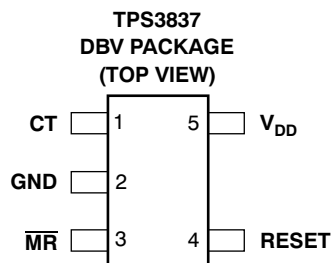
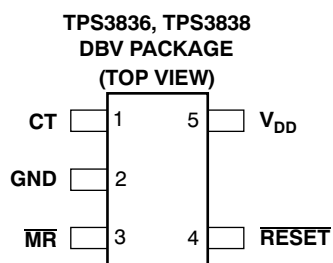

Please be aware that an important notice concerning availability, standard warranty, and use in critical applications of Texas Instruments semiconductor products and disclaimers thereto appears at the end of this data sheet.



This integrated circuit can be damaged by ESD. Texas Instruments recommends that all integrated circuits be handled with appropriate precautions. Failure to observe proper handling and installation procedures can cause damage.

ESD damage can range from subtle performance degradation to complete device failure. Precision integrated circuits may be more susceptible to damage because very small parametric changes could cause the device not to meet its published specifications.

### ORDERING INFORMATION<sup>(1)</sup>

PRODUCT	NOMINAL SUPPLY VOLTAGE	THRESHOLD VOLTAGE ( $V_{IT}$ ) <sup>(2)</sup>
TPS383xE18	1.8 V	1.71 V
TPS383xJ25	2.5 V	2.25 V
TPS383xH30	3.0 V	2.79 V
TPS383xL30	3.0 V	2.64 V
TPS383xK33	3.3 V	2.93 V

- (1) For the most current package and ordering information see the Package Option Addendum at the end of this document, or see the TI web site at [www.ti.com](http://www.ti.com).
- (2) Custom threshold voltages are available. Minimum order quantities apply. Contact factory for details and availability.

### ABSOLUTE MAXIMUM RATINGS<sup>(1)</sup>

Over operating free-air temperature range, unless otherwise noted.

	TPS383xx	UNIT
Supply voltage, $V_{DD}$ <sup>(2)</sup>	7	V
All other pins <sup>(2)(3)</sup>	-0.3 to 7	V
Maximum low output current, $I_{OL}$	5	mA
Maximum high output current, $I_{OH}$	-5	mA
Input clamp current, $I_{IK}$ ( $V_I < 0$ or $V_I > V_{DD}$ )	±10	mA
Output clamp current, $I_{OK}$ ( $V_O < 0$ or $V_O > V_{DD}$ )	±10	mA
Continuous total power dissipation	See <a href="#">Dissipation Ratings</a> Table	
Operating temperature range, $T_A$	-40 to +85	°C
Storage temperature range, $T_{STG}$	-65 to +150	°C
Soldering temperature	+260	°C

- (1) Stresses beyond those listed under [Absolute Maximum Ratings](#) may cause permanent damage to the device. These are stress ratings only, and functional operation of the device at these or any other conditions beyond those indicated under [Recommended Operating Conditions](#) is not implied. Exposure to absolute-maximum-rated conditions for extended periods may affect device reliability.
- (2) All voltage values are with respect to GND.
- (3) If RESET or  $\overline{\text{RESET}}$  are pulled above  $V_{DD}$ , the internal ESD structure will present an effective 1.5 kΩ resistor between these pins, causing leakage current to flow into the RESET or  $\overline{\text{RESET}}$  pin.

### DISSIPATION RATINGS

PACKAGE	$T_A < +25^\circ\text{C}$ POWER RATING	DERATING FACTOR ABOVE $T_A = +25^\circ\text{C}$	$T_A = +70^\circ\text{C}$ POWER RATING	$T_A = +85^\circ\text{C}$ POWER RATING
DBV	437 mW	3.5 mW/°C	280 mW	227 mW

**RECOMMENDED OPERATING CONDITIONS**

	MIN	MAX	UNIT
Supply voltage, $V_{DD}$	1.6	6	V
Voltage range, CT, $\overline{MR}$ , RESET, and $\overline{RESET}$ pins	0	$V_{DD} + 0.3$	V
High-level input voltage, $V_{IH}$	$0.7 \times V_{DD}$		V
Low-level input voltage, $V_{IL}$		$0.3 \times V_{DD}$	V
Input transition rise and fall rate at $\overline{MR}$ , $\Delta t/\Delta V$		100	ns/V
Operating temperature range, $T_A$	-40	+85	°C

**ELECTRICAL CHARACTERISTICS**

Over recommended operating conditions, unless otherwise noted.

PARAMETER		TEST CONDITIONS	MIN	TYP	MAX	UNIT	
$V_{OH}$	High-level output voltage	$\overline{RESET}$ (TPS3836)	$V_{DD} = 3.3\text{ V}$ , $I_{OH} = -2\text{ mA}$	$0.8 \times V_{DD}$		V	
			$V_{DD} = 6\text{ V}$ , $I_{OH} = -3\text{ mA}$				
		$\overline{RESET}$ (TPS3837)	$V_{DD} = 1.8\text{ V}$ , $I_{OH} = -1\text{ mA}$				
			$V_{DD} = 3.3\text{ V}$ , $I_{OL} = -2\text{ mA}$				
$V_{OL}$	Low-level output voltage	$\overline{RESET}$ (TPS3836, TPS3838)	$V_{DD} = 1.8\text{ V}$ , $I_{OL} = 1\text{ mA}$		0.4	V	
			$V_{DD} = 3.3\text{ V}$ , $I_{OL} = 2\text{ mA}$				
		$\overline{RESET}$ (TPS3837)	$V_{DD} = 3.3\text{ V}$ , $I_{OL} = 2\text{ mA}$				
			$V_{DD} = 6\text{ V}$ , $I_{OL} = 3\text{ mA}$				
	Power-up reset voltage <sup>(1)</sup>	TPS3836, TPS3838	$V_{DD} \geq 1.1\text{ V}$ , $I_{OL} = 50\text{ }\mu\text{A}$		0.2	V	
		TPS3837	$V_{DD} \geq 1.1\text{ V}$ , $I_{OL} = -50\text{ }\mu\text{A}$	$0.8 \times V_{DD}$		V	
$V_{IT}$	Negative-going input threshold voltage <sup>(2)</sup>	TPS383xE18	$T_A = -40^\circ\text{C to } +85^\circ\text{C}$	1.66	1.71	1.74	V
		TPS383xJ25		2.18	2.25	2.29	
		TPS383xH30		2.70	2.79	2.85	
		TPS383xL30		2.56	2.64	2.69	
		TPS383xK33		2.84	2.93	2.99	
$V_{HYS}$	Hysteresis at $V_{DD}$ input		$1.7\text{ V} < V_{IT} < 2.5\text{ V}$	30		mV	
			$2.5\text{ V} < V_{IT} < 3.5\text{ V}$	40			
			$3.5\text{ V} < V_{IT} < 5\text{ V}$	50			
$I_{IH}$	High-level input current	$\overline{MR}$ <sup>(3)</sup>	$\overline{MR} = 0.7 \times V_{DD}$ , $V_{DD} = 6\text{ V}$	-40	-60	-100	$\mu\text{A}$
		CT	$CT = V_{DD} = 6\text{ V}$	-25		+25	nA
$I_{IL}$	Low-level input current	$\overline{MR}$ <sup>(3)</sup>	$\overline{MR} = 0\text{ V}$ , $V_{DD} = 6\text{ V}$	-130	-200	-340	$\mu\text{A}$
		CT	$CT = 0\text{ V}$ , $V_{DD} = 6\text{ V}$	-25		+25	nA
$I_{OH}$	High-level output current	TPS3838	$V_{DD} = V_{IT} + 0.2\text{ V}$ , $V_{OH} = V_{DD}$			25	nA
$I_{DD}$	Supply current		$V_{DD} > V_{IT}$ , $V_{DD} < 3\text{ V}$	220	400		nA
			$V_{DD} > V_{IT}$ , $V_{DD} > 3\text{ V}$	250	450		
			$V_{DD} < V_{IT}$	10	15		$\mu\text{A}$
	Internal pull-up resistor at $\overline{MR}$			30		k $\Omega$	
$C_I$	Input capacitance at $\overline{MR}$ and CT		$V_I = 0\text{ V to } V_{DD}$	5			pF

(1) The lowest voltage at which the  $\overline{RESET}$  output becomes active.  $t_R$ ,  $V_{DD} \geq 15\text{ }\mu\text{s/V}$ .

(2) To ensure best stability of the threshold voltage, a bypass capacitor (ceramic, 0.1  $\mu\text{F}$ ) should be placed near the supply terminal.

(3) If manual reset is unused,  $\overline{MR}$  should be connected to  $V_{DD}$  to minimize current consumption.

## SWITCHING CHARACTERISTICS

At  $T_A = +25^\circ\text{C}$ ,  $R_L = 1\text{ M}\Omega$ , and  $C_L = 50\text{ pF}$ , unless otherwise noted.

PARAMETER		TEST CONDITIONS	MIN	TYP	MAX	UNIT
$t_D$	Delay time	$V_{DD} \geq V_{IT} + 0.2\text{ V}$ , $\overline{MR} = 0.7 \times V_{DD}$ , CT = GND, See <a href="#">Timing Diagram</a>	5	10	15	ms
		$V_{DD} \geq V_{IT} + 0.2\text{ V}$ , $\overline{MR} = 0.7 \times V_{DD}$ , CT = $V_{DD}$ , See <a href="#">Timing Diagram</a>	100	200	300	
$t_{PHL}$	Propagation (delay) time, high-to-low-level output	$V_{DD}$ to RESET delay (TPS3836, TPS3838)	$V_{IL} = V_{IT} - 0.2\text{ V}$ , $V_{IH} = V_{IT} + 0.2\text{ V}$		10	$\mu\text{s}$
			$V_{IL} = 1.6\text{ V}$		50	
$t_{PLH}$	Propagation (delay) time, low-to-high-level output	$V_{DD}$ to RESET delay (TPS3837)	$V_{IL} = V_{IT} - 0.2\text{ V}$ , $V_{IH} = V_{IT} + 0.2\text{ V}$		10	$\mu\text{s}$
			$V_{IL} = 1.6\text{ V}$		50	
$t_{PHL}$	Propagation (delay) time, high-to-low-level output	$\overline{MR}$ to RESET delay (TPS3836, TPS3838)	$V_{DD} \geq V_{IT} + 0.2\text{ V}$ , $V_{IL} = 0.3 \times V_{DD}$ , $V_{IL} = 0.7 \times V_{DD}$		0.1	$\mu\text{s}$
$t_{PLH}$	Propagation (delay) time, low-to-high-level output	$\overline{MR}$ to RESET delay (TPS3837)	$V_{DD} \geq V_{IT} + 0.2\text{ V}$ , $V_{IL} = 0.3 \times V_{DD}$ , $V_{IL} = 0.7 \times V_{DD}$		0.1	$\mu\text{s}$

## TIMING REQUIREMENTS

At  $T_A = +25^\circ\text{C}$ ,  $R_L = 1\text{ M}\Omega$ , and  $C_L = 50\text{ pF}$ , unless otherwise noted.

PARAMETER		TEST CONDITIONS	MIN	TYP	MAX	UNIT
$t_W$	Pulse width	at $V_{DD}$	$V_{IH} = V_{IT} + 0.2\text{ V}$ , $V_{IL} = V_{IT} - 0.2\text{ V}$		6	$\mu\text{s}$
		at $\overline{MR}$	$V_{DD} \geq V_{IT} + 0.2\text{ V}$ , $V_{IL} = 0.3 \times V_{DD}$ , $V_{IH} = 0.7 \times V_{DD}$		1	

**FUNCTIONAL BLOCK DIAGRAM**

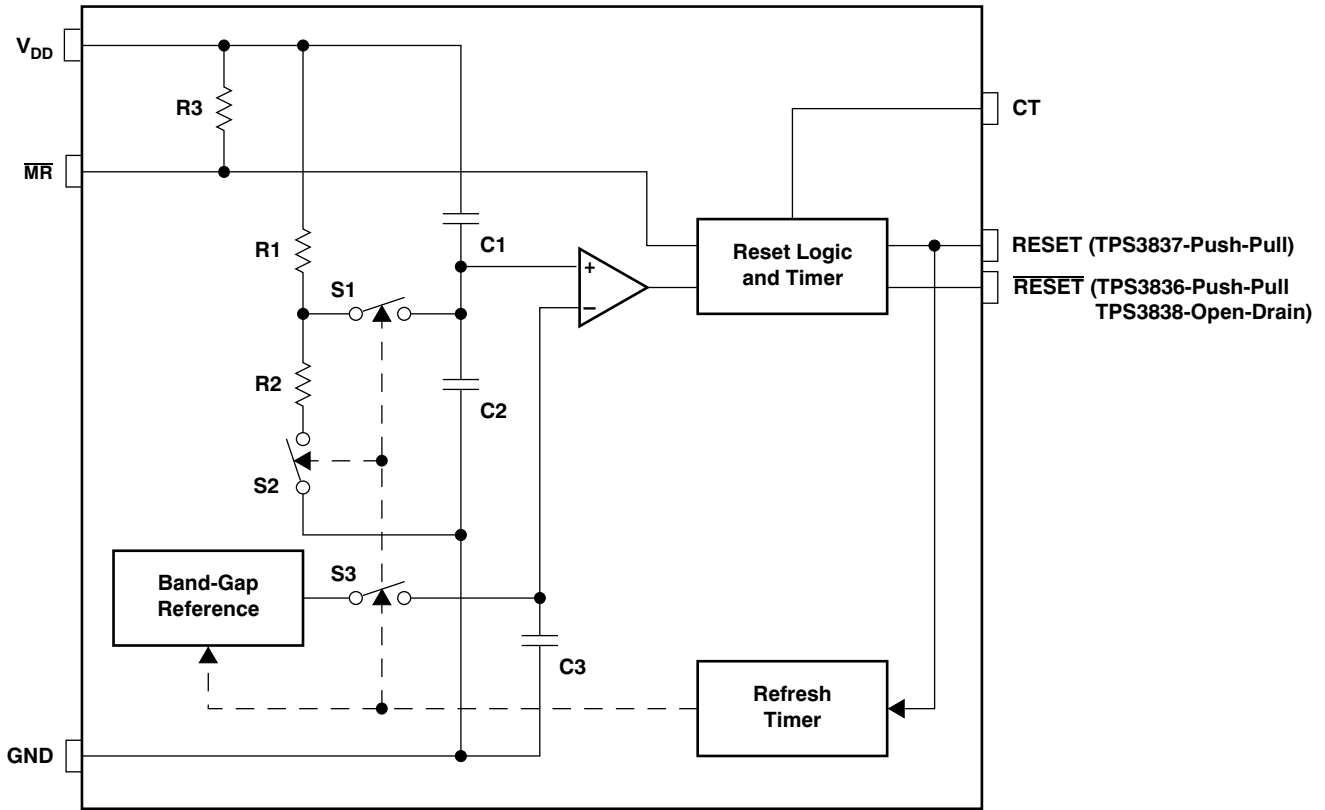

**FUNCTION TABLE**

$\overline{MR}$	$V_{DD} > V_{IT}$	RESET <sup>(1)</sup>	RESET <sup>(2)</sup>
L	0	L	H
L	1	L	H
H	0	L	H
H	1	H	L

(1) TPS3836 and TPS3838.  
 (2) TPS3837.

### TIMING DIAGRAM

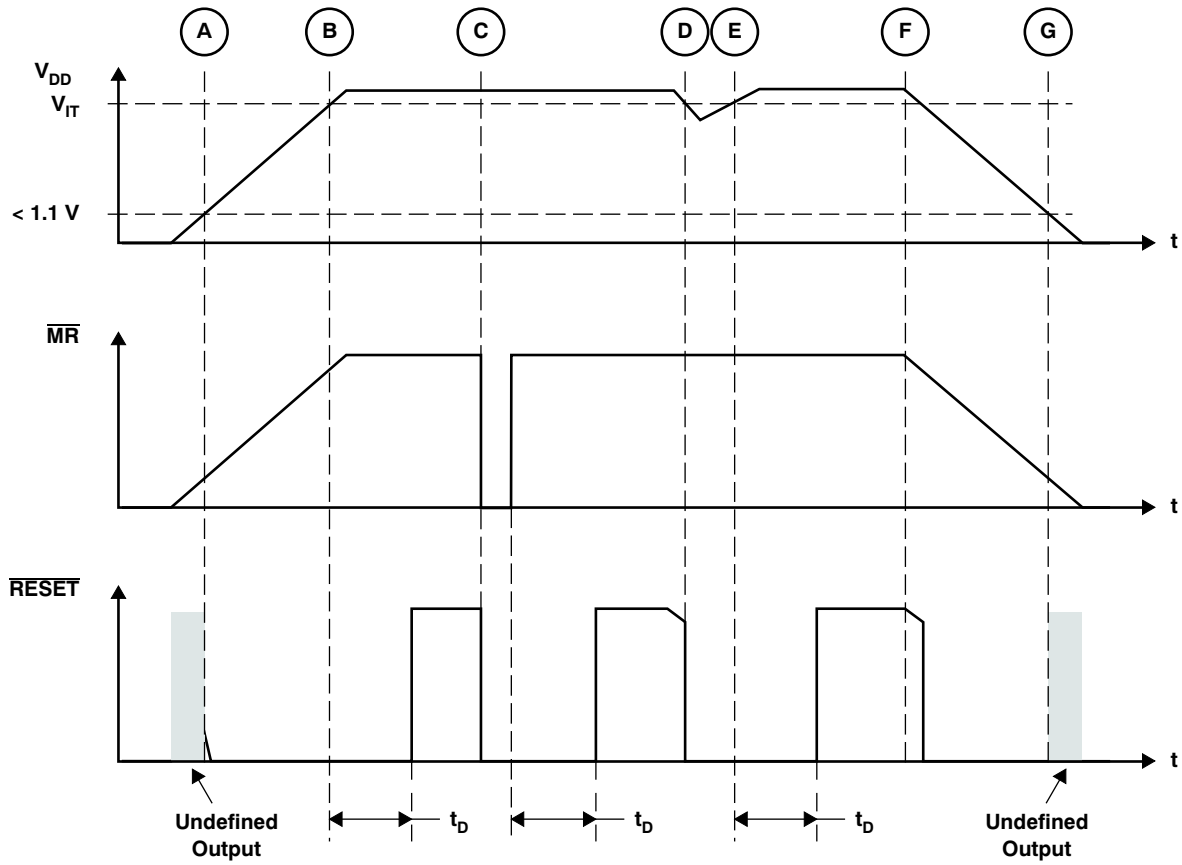

### TYPICAL CHARACTERISTICS

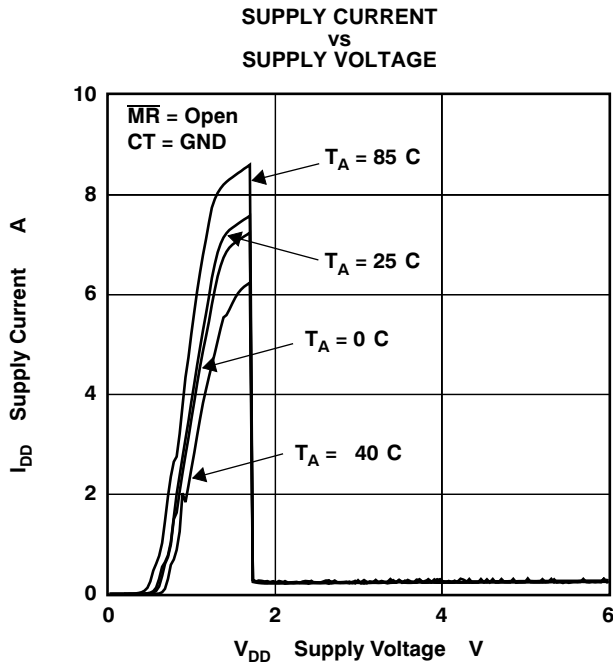

Figure 1.

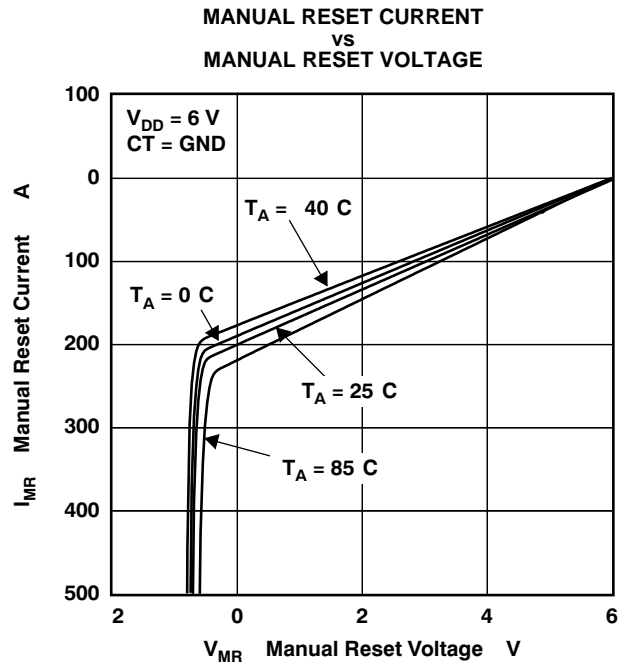

Figure 2.

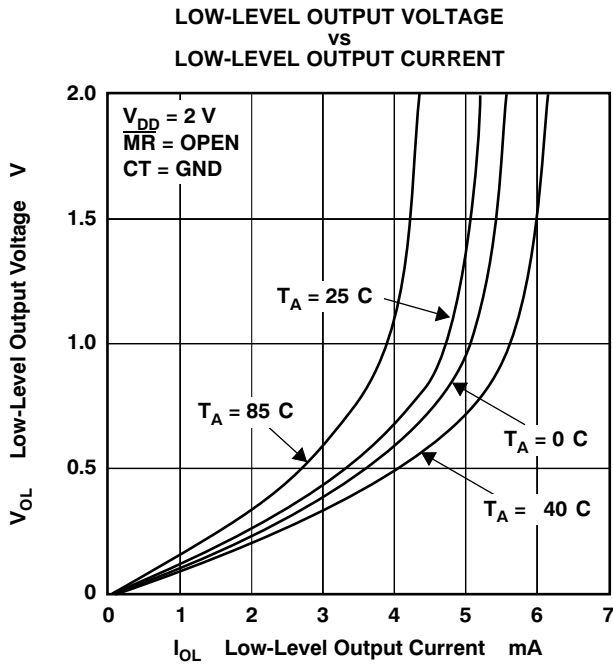

Figure 3.

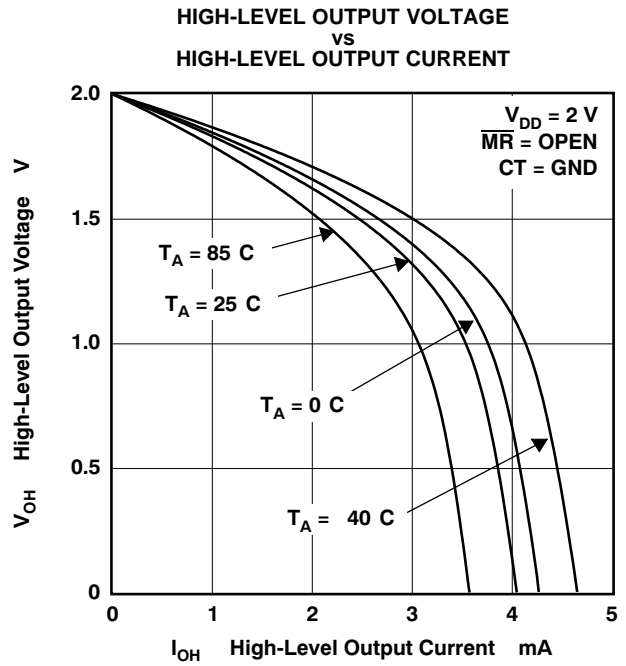

Figure 4.

**TYPICAL CHARACTERISTICS (continued)**

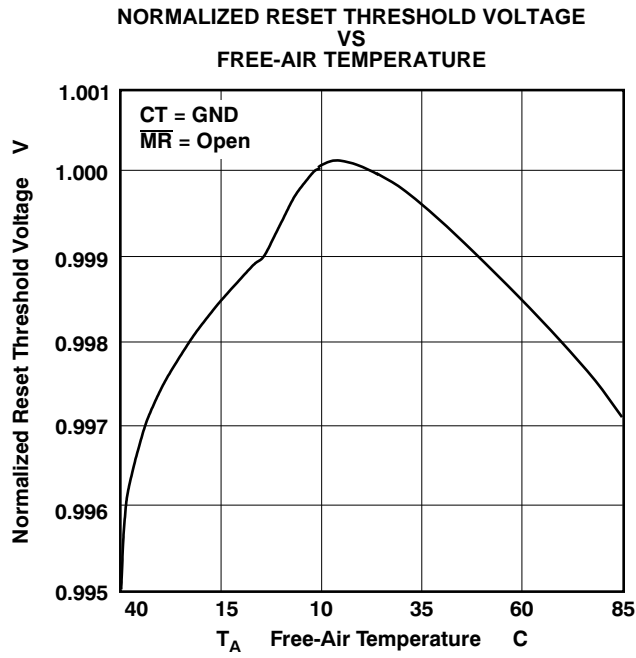

Figure 5.

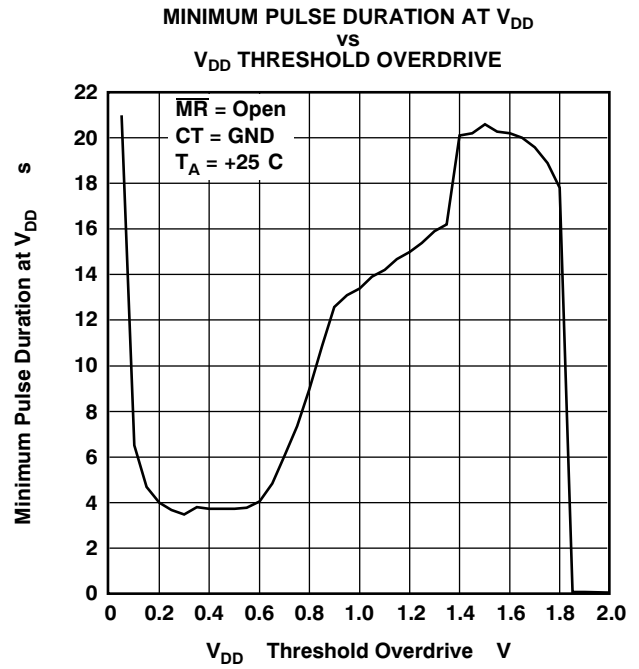

Figure 6.

**PACKAGING INFORMATION**

Orderable Device	Status <sup>(1)</sup>	Package Type	Package Drawing	Pins	Package Qty	Eco Plan <sup>(2)</sup>	Lead/Ball Finish	MSL Peak Temp <sup>(3)</sup>
TPS3836E18DBVR	ACTIVE	SOT-23	DBV	5	3000	Green (RoHS & no Sb/Br)	CU NIPDAU	Level-1-260C-UNLIM
TPS3836E18DBVRG4	ACTIVE	SOT-23	DBV	5	3000	Green (RoHS & no Sb/Br)	CU NIPDAU	Level-1-260C-UNLIM
TPS3836E18DBVT	ACTIVE	SOT-23	DBV	5	250	Green (RoHS & no Sb/Br)	CU NIPDAU	Level-1-260C-UNLIM
TPS3836E18DBVTG4	ACTIVE	SOT-23	DBV	5	250	Green (RoHS & no Sb/Br)	CU NIPDAU	Level-1-260C-UNLIM
TPS3836H30DBVR	ACTIVE	SOT-23	DBV	5	3000	Green (RoHS & no Sb/Br)	CU NIPDAU	Level-1-260C-UNLIM
TPS3836H30DBVRG4	ACTIVE	SOT-23	DBV	5	3000	Green (RoHS & no Sb/Br)	CU NIPDAU	Level-1-260C-UNLIM
TPS3836H30DBVT	ACTIVE	SOT-23	DBV	5	250	Green (RoHS & no Sb/Br)	CU NIPDAU	Level-1-260C-UNLIM
TPS3836H30DBVTG4	ACTIVE	SOT-23	DBV	5	250	Green (RoHS & no Sb/Br)	CU NIPDAU	Level-1-260C-UNLIM
TPS3836J25DBVR	ACTIVE	SOT-23	DBV	5	3000	Green (RoHS & no Sb/Br)	CU NIPDAU	Level-1-260C-UNLIM
TPS3836J25DBVRG4	ACTIVE	SOT-23	DBV	5	3000	Green (RoHS & no Sb/Br)	CU NIPDAU	Level-1-260C-UNLIM
TPS3836J25DBVT	ACTIVE	SOT-23	DBV	5	250	Green (RoHS & no Sb/Br)	CU NIPDAU	Level-1-260C-UNLIM
TPS3836J25DBVTG4	ACTIVE	SOT-23	DBV	5	250	Green (RoHS & no Sb/Br)	CU NIPDAU	Level-1-260C-UNLIM
TPS3836K33DBVR	ACTIVE	SOT-23	DBV	5	3000	Green (RoHS & no Sb/Br)	CU NIPDAU	Level-1-260C-UNLIM
TPS3836K33DBVRG4	ACTIVE	SOT-23	DBV	5	3000	Green (RoHS & no Sb/Br)	CU NIPDAU	Level-1-260C-UNLIM
TPS3836K33DBVT	ACTIVE	SOT-23	DBV	5	250	Green (RoHS & no Sb/Br)	CU NIPDAU	Level-1-260C-UNLIM
TPS3836K33DBVTG4	ACTIVE	SOT-23	DBV	5	250	Green (RoHS & no Sb/Br)	CU NIPDAU	Level-1-260C-UNLIM
TPS3836L30DBVR	ACTIVE	SOT-23	DBV	5	3000	Green (RoHS & no Sb/Br)	CU NIPDAU	Level-1-260C-UNLIM
TPS3836L30DBVRG4	ACTIVE	SOT-23	DBV	5	3000	Green (RoHS & no Sb/Br)	CU NIPDAU	Level-1-260C-UNLIM
TPS3836L30DBVT	ACTIVE	SOT-23	DBV	5	250	Green (RoHS & no Sb/Br)	CU NIPDAU	Level-1-260C-UNLIM
TPS3836L30DBVTG4	ACTIVE	SOT-23	DBV	5	250	Green (RoHS & no Sb/Br)	CU NIPDAU	Level-1-260C-UNLIM
TPS3837E18DBVR	ACTIVE	SOT-23	DBV	5	3000	Green (RoHS & no Sb/Br)	CU NIPDAU	Level-1-260C-UNLIM
TPS3837E18DBVRG4	ACTIVE	SOT-23	DBV	5	3000	Green (RoHS & no Sb/Br)	CU NIPDAU	Level-1-260C-UNLIM
TPS3837E18DBVT	ACTIVE	SOT-23	DBV	5	250	Green (RoHS & no Sb/Br)	CU NIPDAU	Level-1-260C-UNLIM
TPS3837E18DBVTG4	ACTIVE	SOT-23	DBV	5	250	Green (RoHS & no Sb/Br)	CU NIPDAU	Level-1-260C-UNLIM
TPS3837J25DBVR	ACTIVE	SOT-23	DBV	5	3000	Green (RoHS & no Sb/Br)	CU NIPDAU	Level-1-260C-UNLIM

Orderable Device	Status <sup>(1)</sup>	Package Type	Package Drawing	Pins	Package Qty	Eco Plan <sup>(2)</sup>	Lead/Ball Finish	MSL Peak Temp <sup>(3)</sup>
TPS3837J25DBVRG4	ACTIVE	SOT-23	DBV	5	3000	Green (RoHS & no Sb/Br)	CU NIPDAU	Level-1-260C-UNLIM
TPS3837J25DBVT	ACTIVE	SOT-23	DBV	5	250	Green (RoHS & no Sb/Br)	CU NIPDAU	Level-1-260C-UNLIM
TPS3837J25DBVTG4	ACTIVE	SOT-23	DBV	5	250	Green (RoHS & no Sb/Br)	CU NIPDAU	Level-1-260C-UNLIM
TPS3837K33DBVR	ACTIVE	SOT-23	DBV	5	3000	Green (RoHS & no Sb/Br)	CU NIPDAU	Level-1-260C-UNLIM
TPS3837K33DBVRG4	ACTIVE	SOT-23	DBV	5	3000	Green (RoHS & no Sb/Br)	CU NIPDAU	Level-1-260C-UNLIM
TPS3837K33DBVT	ACTIVE	SOT-23	DBV	5	250	Green (RoHS & no Sb/Br)	CU NIPDAU	Level-1-260C-UNLIM
TPS3837K33DBVTG4	ACTIVE	SOT-23	DBV	5	250	Green (RoHS & no Sb/Br)	CU NIPDAU	Level-1-260C-UNLIM
TPS3837L30DBVR	ACTIVE	SOT-23	DBV	5	3000	Green (RoHS & no Sb/Br)	CU NIPDAU	Level-1-260C-UNLIM
TPS3837L30DBVRG4	ACTIVE	SOT-23	DBV	5	3000	Green (RoHS & no Sb/Br)	CU NIPDAU	Level-1-260C-UNLIM
TPS3837L30DBVT	ACTIVE	SOT-23	DBV	5	250	Green (RoHS & no Sb/Br)	CU NIPDAU	Level-1-260C-UNLIM
TPS3837L30DBVTG4	ACTIVE	SOT-23	DBV	5	250	Green (RoHS & no Sb/Br)	CU NIPDAU	Level-1-260C-UNLIM
TPS3838E18DBVR	ACTIVE	SOT-23	DBV	5	3000	Green (RoHS & no Sb/Br)	CU NIPDAU	Level-1-260C-UNLIM
TPS3838E18DBVRG4	ACTIVE	SOT-23	DBV	5	3000	Green (RoHS & no Sb/Br)	CU NIPDAU	Level-1-260C-UNLIM
TPS3838E18DBVT	ACTIVE	SOT-23	DBV	5	250	Green (RoHS & no Sb/Br)	CU NIPDAU	Level-1-260C-UNLIM
TPS3838E18DBVTG4	ACTIVE	SOT-23	DBV	5	250	Green (RoHS & no Sb/Br)	CU NIPDAU	Level-1-260C-UNLIM
TPS3838J25DBVR	ACTIVE	SOT-23	DBV	5	3000	Green (RoHS & no Sb/Br)	CU NIPDAU	Level-1-260C-UNLIM
TPS3838J25DBVRG4	ACTIVE	SOT-23	DBV	5	3000	Green (RoHS & no Sb/Br)	CU NIPDAU	Level-1-260C-UNLIM
TPS3838J25DBVT	ACTIVE	SOT-23	DBV	5	250	Green (RoHS & no Sb/Br)	CU NIPDAU	Level-1-260C-UNLIM
TPS3838J25DBVTG4	ACTIVE	SOT-23	DBV	5	250	Green (RoHS & no Sb/Br)	CU NIPDAU	Level-1-260C-UNLIM
TPS3838K33DBVR	ACTIVE	SOT-23	DBV	5	3000	Green (RoHS & no Sb/Br)	CU NIPDAU	Level-1-260C-UNLIM
TPS3838K33DBVRG4	ACTIVE	SOT-23	DBV	5	3000	Green (RoHS & no Sb/Br)	CU NIPDAU	Level-1-260C-UNLIM
TPS3838K33DBVT	ACTIVE	SOT-23	DBV	5	250	Green (RoHS & no Sb/Br)	CU NIPDAU	Level-1-260C-UNLIM
TPS3838K33DBVTG4	ACTIVE	SOT-23	DBV	5	250	Green (RoHS & no Sb/Br)	CU NIPDAU	Level-1-260C-UNLIM
TPS3838L30DBVR	ACTIVE	SOT-23	DBV	5	3000	Green (RoHS & no Sb/Br)	CU NIPDAU	Level-1-260C-UNLIM
TPS3838L30DBVRG4	ACTIVE	SOT-23	DBV	5	3000	Green (RoHS & no Sb/Br)	CU NIPDAU	Level-1-260C-UNLIM
TPS3838L30DBVT	ACTIVE	SOT-23	DBV	5	250	Green (RoHS & no Sb/Br)	CU NIPDAU	Level-1-260C-UNLIM

Orderable Device	Status <sup>(1)</sup>	Package Type	Package Drawing	Pins	Package Qty	Eco Plan <sup>(2)</sup>	Lead/Ball Finish	MSL Peak Temp <sup>(3)</sup>
TPS3838L30DBVTG4	ACTIVE	SOT-23	DBV	5	250	Green (RoHS & no Sb/Br)	CU NIPDAU	Level-1-260C-UNLIM

<sup>(1)</sup> The marketing status values are defined as follows:

**ACTIVE:** Product device recommended for new designs.

**LIFEBUY:** TI has announced that the device will be discontinued, and a lifetime-buy period is in effect.

**NRND:** Not recommended for new designs. Device is in production to support existing customers, but TI does not recommend using this part in a new design.

**PREVIEW:** Device has been announced but is not in production. Samples may or may not be available.

**OBSELETE:** TI has discontinued the production of the device.

<sup>(2)</sup> Eco Plan - The planned eco-friendly classification: Pb-Free (RoHS), Pb-Free (RoHS Exempt), or Green (RoHS & no Sb/Br) - please check <http://www.ti.com/productcontent> for the latest availability information and additional product content details.

**TBD:** The Pb-Free/Green conversion plan has not been defined.

**Pb-Free (RoHS):** TI's terms "Lead-Free" or "Pb-Free" mean semiconductor products that are compatible with the current RoHS requirements for all 6 substances, including the requirement that lead not exceed 0.1% by weight in homogeneous materials. Where designed to be soldered at high temperatures, TI Pb-Free products are suitable for use in specified lead-free processes.

**Pb-Free (RoHS Exempt):** This component has a RoHS exemption for either 1) lead-based flip-chip solder bumps used between the die and package, or 2) lead-based die adhesive used between the die and leadframe. The component is otherwise considered Pb-Free (RoHS compatible) as defined above.

**Green (RoHS & no Sb/Br):** TI defines "Green" to mean Pb-Free (RoHS compatible), and free of Bromine (Br) and Antimony (Sb) based flame retardants (Br or Sb do not exceed 0.1% by weight in homogeneous material)

<sup>(3)</sup> MSL, Peak Temp. -- The Moisture Sensitivity Level rating according to the JEDEC industry standard classifications, and peak solder temperature.

**Important Information and Disclaimer:**The information provided on this page represents TI's knowledge and belief as of the date that it is provided. TI bases its knowledge and belief on information provided by third parties, and makes no representation or warranty as to the accuracy of such information. Efforts are underway to better integrate information from third parties. TI has taken and continues to take reasonable steps to provide representative and accurate information but may not have conducted destructive testing or chemical analysis on incoming materials and chemicals. TI and TI suppliers consider certain information to be proprietary, and thus CAS numbers and other limited information may not be available for release.

In no event shall TI's liability arising out of such information exceed the total purchase price of the TI part(s) at issue in this document sold by TI to Customer on an annual basis.



## IMPORTANT NOTICE

Texas Instruments Incorporated and its subsidiaries (TI) reserve the right to make corrections, modifications, enhancements, improvements, and other changes to its products and services at any time and to discontinue any product or service without notice. Customers should obtain the latest relevant information before placing orders and should verify that such information is current and complete. All products are sold subject to TI's terms and conditions of sale supplied at the time of order acknowledgment.

TI warrants performance of its hardware products to the specifications applicable at the time of sale in accordance with TI's standard warranty. Testing and other quality control techniques are used to the extent TI deems necessary to support this warranty. Except where mandated by government requirements, testing of all parameters of each product is not necessarily performed.

TI assumes no liability for applications assistance or customer product design. Customers are responsible for their products and applications using TI components. To minimize the risks associated with customer products and applications, customers should provide adequate design and operating safeguards.

TI does not warrant or represent that any license, either express or implied, is granted under any TI patent right, copyright, mask work right, or other TI intellectual property right relating to any combination, machine, or process in which TI products or services are used. Information published by TI regarding third-party products or services does not constitute a license from TI to use such products or services or a warranty or endorsement thereof. Use of such information may require a license from a third party under the patents or other intellectual property of the third party, or a license from TI under the patents or other intellectual property of TI.

Reproduction of information in TI data books or data sheets is permissible only if reproduction is without alteration and is accompanied by all associated warranties, conditions, limitations, and notices. Reproduction of this information with alteration is an unfair and deceptive business practice. TI is not responsible or liable for such altered documentation.

Resale of TI products or services with statements different from or beyond the parameters stated by TI for that product or service voids all express and any implied warranties for the associated TI product or service and is an unfair and deceptive business practice. TI is not responsible or liable for any such statements.

Following are URLs where you can obtain information on other Texas Instruments products and application solutions:

<b>Products</b>		<b>Applications</b>	
Amplifiers	<a href="http://amplifier.ti.com">amplifier.ti.com</a>	Audio	<a href="http://www.ti.com/audio">www.ti.com/audio</a>
Data Converters	<a href="http://dataconverter.ti.com">dataconverter.ti.com</a>	Automotive	<a href="http://www.ti.com/automotive">www.ti.com/automotive</a>
DSP	<a href="http://dsp.ti.com">dsp.ti.com</a>	Broadband	<a href="http://www.ti.com/broadband">www.ti.com/broadband</a>
Interface	<a href="http://interface.ti.com">interface.ti.com</a>	Digital Control	<a href="http://www.ti.com/digitalcontrol">www.ti.com/digitalcontrol</a>
Logic	<a href="http://logic.ti.com">logic.ti.com</a>	Military	<a href="http://www.ti.com/military">www.ti.com/military</a>
Power Mgmt	<a href="http://power.ti.com">power.ti.com</a>	Optical Networking	<a href="http://www.ti.com/opticalnetwork">www.ti.com/opticalnetwork</a>
Microcontrollers	<a href="http://microcontroller.ti.com">microcontroller.ti.com</a>	Security	<a href="http://www.ti.com/security">www.ti.com/security</a>
Low Power Wireless	<a href="http://www.ti.com/lpw">www.ti.com/lpw</a>	Telephony	<a href="http://www.ti.com/telephony">www.ti.com/telephony</a>
		Video & Imaging	<a href="http://www.ti.com/video">www.ti.com/video</a>
		Wireless	<a href="http://www.ti.com/wireless">www.ti.com/wireless</a>

Mailing Address: Texas Instruments  
Post Office Box 655303 Dallas, Texas 75265