

- 3-Pin SOT-23 Package
- Supply Current of 9  $\mu$ A (Typical)
- Precision Supply Voltage Monitor  
2.5 V, 3 V, 3.3 V, 5 V
- Power-On Reset Generator With Fixed  
Delay Time of 200 ms
- Pin-For-Pin Compatible With MAX 809
- Temperature Range . . .  $-40^{\circ}\text{C}$  to  $85^{\circ}\text{C}$

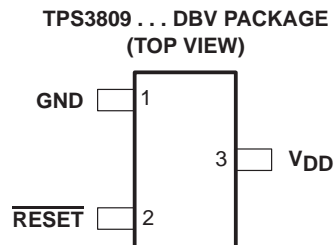

## description

The TPS3809 family of supervisory circuits provides circuit initialization and timing supervision, primarily for DSPs and processor-based systems.

During power-on,  $\overline{\text{RESET}}$  is asserted when the supply voltage  $V_{\text{DD}}$  becomes higher than 1.1 V. Thereafter, the supervisory circuit monitors  $V_{\text{DD}}$  and keeps  $\overline{\text{RESET}}$  active as long as  $V_{\text{DD}}$  remains below the threshold voltage  $V_{\text{IT}}$ . An internal timer delays the return of the output to the inactive state (high) to ensure proper system reset. The delay time,  $t_{\text{d(typ)}} = 200$  ms, starts after  $V_{\text{DD}}$  has risen above the threshold voltage  $V_{\text{IT}}$ . When the supply voltage drops below the threshold voltage  $V_{\text{IT}}$ , the output becomes active (low) again. No external components are required. All the devices of this family have a fixed sense-threshold voltage  $V_{\text{IT}}$  set by an internal voltage divider.

The product spectrum is designed for supply voltages of 2.5 V, 3 V, 3.3 V, and 5 V. The circuits are available in a 3-pin SOT-23. The TPS3809 devices are characterized for operation over a temperature range of  $-40^{\circ}\text{C}$  to  $85^{\circ}\text{C}$ .

## typical applications

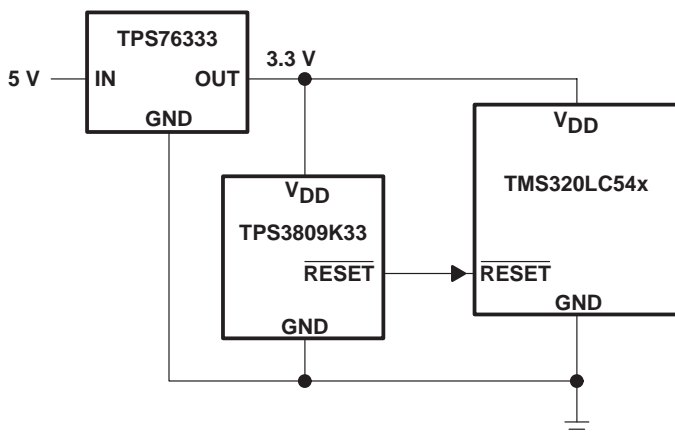

- Applications Using DSPs, Microcontrollers, or Microprocessors
- Wireless Communication Systems
- Portable/Battery-Powered Equipment
- Programmable Controls
- Intelligent Instruments
- Industrial Equipment
- Notebook/Desktop Computers
- Automotive Systems



Please be aware that an important notice concerning availability, standard warranty, and use in critical applications of Texas Instruments semiconductor products and disclaimers thereto appears at the end of this data sheet.

# TPS3809J25, TPS3809L30, TPS3809K33, TPS3809I50 3-PIN SUPPLY VOLTAGE SUPERVISORS

SLVS228 – AUGUST 1999

## AVAILABLE OPTIONS

T <sub>A</sub>	DEVICE NAME		THRESHOLD VOLTAGE	MARKING
-40°C to 85°C	TPS3809J25DBVR†	TPS3809J25DBVT‡	2.25 V	PCZI
	TPS3809L30DBVR†	TPS3809L30DBVT‡	2.64 V	PDAI
	TPS3809K33DBVR†	TPS3809K33DBVT‡	2.93 V	PDBI
	TPS3809I50DBVR†	TPS3809I50DBVT‡	4.55 V	PDCI

† The DBVR passive indicates tape and reel of 3000 parts.

‡ The DBVT passive indicates tape and reel of 250 parts.

## FUNCTION/TRUTH TABLE, TPS3809

V <sub>DD</sub> >V <sub>IT</sub>	$\overline{\text{RESET}}$
0	L
1	H

## ORDERING INFORMATION

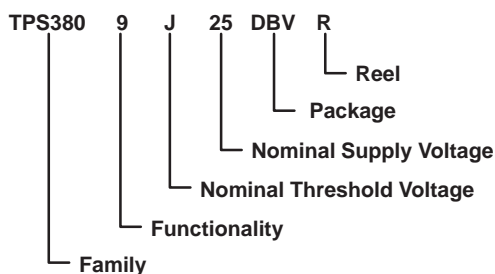

## functional block diagram

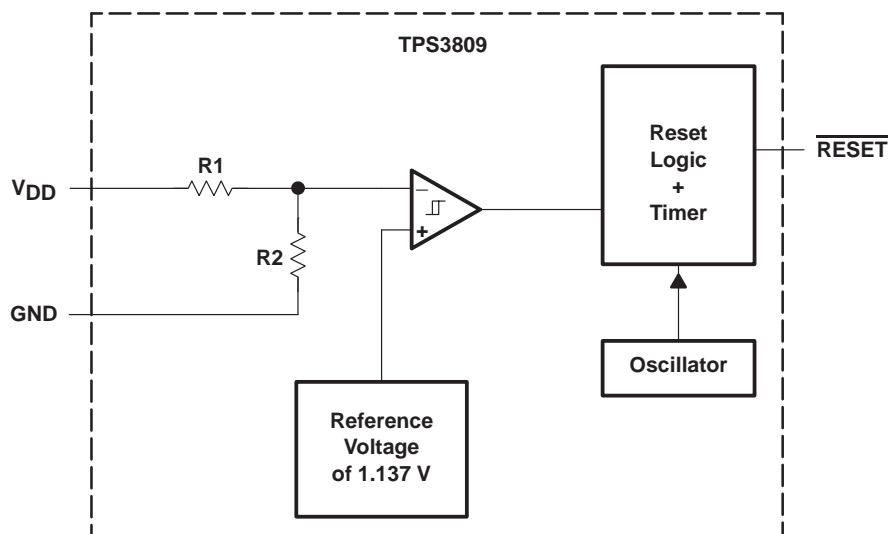

timing diagram

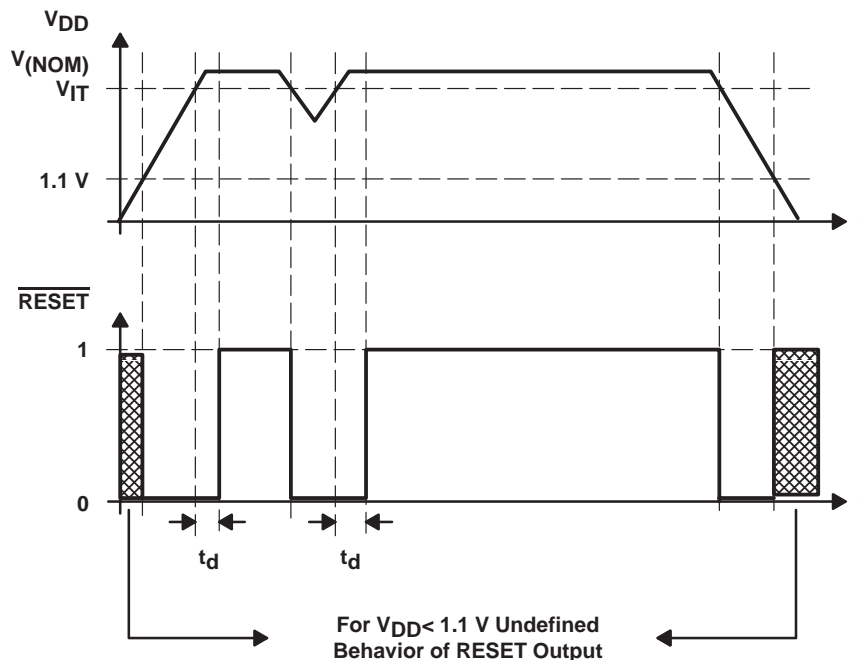

absolute maximum ratings over operating free-air temperature (unless otherwise noted)<sup>†</sup>

Supply voltage, $V_{DD}$ (see Note 1)	7 V
All other pins (see Note 1)	-0.3 V to 7 V
Maximum low output current, $I_{OL}$	5 mA
Maximum high output current, $I_{OH}$	-5 mA
Input clamp current, $I_{IK}$ ( $V_I < 0$ or $V_I > V_{DD}$ )	$\pm 20$ mA
Output clamp current, $I_{OK}$ ( $V_O < 0$ or $V_O > V_{DD}$ )	$\pm 20$ mA
Continuous total power dissipation	See Dissipation Rating Table
Operating free-air temperature range, $T_A$	-40°C to 85°C
Storage temperature range, $T_{stg}$	-65°C to 150°C
Soldering temperature	260°C

<sup>†</sup> Stresses beyond those listed under "absolute maximum ratings" may cause permanent damage to the device. These are stress ratings only, and functional operation of the device at these or any other conditions beyond those indicated under "recommended operating conditions" is not implied. Exposure to absolute-maximum-rated conditions for extended periods may affect device reliability.

NOTE 1: All voltage values are with respect to GND. For reliable operation the device should not be operated at 7 V for more than  $t=1000\text{h}$  continuously.

DISSIPATION RATING TABLE

PACKAGE	$T_A < 25^\circ\text{C}$ POWER RATING	DERATING FACTOR ABOVE $T_A = 25^\circ\text{C}$	$T_A = 70^\circ\text{C}$ POWER RATING	$T_A = 85^\circ\text{C}$ POWER RATING
DBV	437 mW	3.5 mW/°C	280 mW	227 mW

recommended operating conditions at specified temperature range

	MIN	MAX	UNIT
Supply voltage, $V_{DD}$	2	6	V
Operating free-air temperature range, $T_A$	-40	85	°C

# TPS3809J25, TPS3809L30, TPS3809K33, TPS3809I50

## 3-PIN SUPPLY VOLTAGE SUPERVISORS

SLVS228 – AUGUST 1999

**electrical characteristics over recommended operating free-air temperature range (unless otherwise noted)**

PARAMETER		TEST CONDITIONS	MIN	TYP	MAX	UNIT	
V <sub>OH</sub>	High-level output voltage	V <sub>DD</sub> = 2.5 V to 6 V, I <sub>OH</sub> = -500 μA	V <sub>DD</sub> - 0.2			V	
		V <sub>DD</sub> = 3.3 V, I <sub>OH</sub> = -2 mA	V <sub>DD</sub> - 0.4				
		V <sub>DD</sub> = 6 V, I <sub>OH</sub> = -4 mA	V <sub>DD</sub> - 0.4				
V <sub>OL</sub>	Low-level output voltage	V <sub>DD</sub> = 2 V to 6 V, I <sub>OL</sub> = 500 μA	0.2			V	
		V <sub>DD</sub> = 3.3 V, I <sub>OL</sub> = 2 mA	0.4				
		V <sub>DD</sub> = 6 V, I <sub>OL</sub> = 4 mA	0.4				
Power-up reset voltage (see Note 2)		V <sub>DD</sub> ≥ 1.1 V, I <sub>OL</sub> = 50 μA	0.2			V	
V <sub>IT-</sub>	Negative-going input threshold voltage (see Note 3)	T <sub>A</sub> = 40°C to 85°C	TPS3809J25	2.20	2.25	2.30	V
			TPS3809L30	2.58	2.64	2.70	
			TPS3809K33	2.87	2.93	2.99	
			TPS3809I50	4.45	4.55	4.65	
V <sub>hys</sub>	Hysteresis		TPS3809J25	30		mV	
			TPS3809L30	35			
			TPS3809K33	40			
			TPS3809I50	60			
I <sub>DD</sub>	Supply current	V <sub>DD</sub> = 2 V, Output unconnected	9		12	μA	
		V <sub>DD</sub> = 6 V, Output unconnected	20		25		
C <sub>i</sub>	Input capacitance	V <sub>I</sub> = 0 V to V <sub>DD</sub>	5			pF	

NOTES: 2. The lowest supply voltage at which  $\overline{\text{RESET}}$  becomes active.  $t_r, V_{DD} \geq 15 \mu\text{s/V}$ .  
 3. To ensure best stability of the threshold voltage, a bypass capacitor (0.1 μF ceramic) should be placed near the supply terminals.

### timing requirements at R<sub>L</sub> = 1 MΩ, C<sub>L</sub> = 50 pF, T<sub>A</sub> = 25°C

PARAMETER		TEST CONDITIONS	MIN	TYP	MAX	UNIT
t <sub>w</sub>	Pulse width	at V <sub>DD</sub> , V <sub>DD</sub> = V <sub>IT-</sub> + 0.2 V, V <sub>DD</sub> = V <sub>IT-</sub> - 0.2 V	3			μs

### switching characteristics at R<sub>L</sub> = 1 MΩ, C<sub>L</sub> = 50 pF, T<sub>A</sub> = 25°C

PARAMETER		TEST CONDITIONS	MIN	TYP	MAX	UNIT
t <sub>d</sub>	Delay time	V <sub>DD</sub> ≥ V <sub>IT-</sub> + 0.2 V, See timing diagram	120	200	280	ms
t <sub>PHL</sub>	Propagation (delay) time, high-to-low-level output	V <sub>DD</sub> to $\overline{\text{RESET}}$ delay, V <sub>IL</sub> = V <sub>IT-</sub> - 0.2 V, V <sub>IH</sub> = V <sub>IT-</sub> + 0.2 V	1			μs



PACKAGING INFORMATION

Orderable Device	Status <sup>(1)</sup>	Package Type	Package Drawing	Pins	Package Qty	Eco Plan <sup>(2)</sup>	Lead/Ball Finish	MSL Peak Temp <sup>(3)</sup>
TPS3809I50DBVR	ACTIVE	SOT-23	DBV	3	3000	Green (RoHS & no Sb/Br)	CU NIPDAU	Level-1-260C-UNLIM
TPS3809I50DBVRG4	ACTIVE	SOT-23	DBV	3	3000	Green (RoHS & no Sb/Br)	CU NIPDAU	Level-1-260C-UNLIM
TPS3809I50DBVT	ACTIVE	SOT-23	DBV	3	250	Green (RoHS & no Sb/Br)	CU NIPDAU	Level-1-260C-UNLIM
TPS3809I50DBVTG4	ACTIVE	SOT-23	DBV	3	250	Green (RoHS & no Sb/Br)	CU NIPDAU	Level-1-260C-UNLIM
TPS3809J25DBVR	ACTIVE	SOT-23	DBV	3	3000	Green (RoHS & no Sb/Br)	CU NIPDAU	Level-1-260C-UNLIM
TPS3809J25DBVRG4	ACTIVE	SOT-23	DBV	3	3000	Green (RoHS & no Sb/Br)	CU NIPDAU	Level-1-260C-UNLIM
TPS3809J25DBVT	ACTIVE	SOT-23	DBV	3	250	Green (RoHS & no Sb/Br)	CU NIPDAU	Level-1-260C-UNLIM
TPS3809K33DBVR	ACTIVE	SOT-23	DBV	3	3000	Green (RoHS & no Sb/Br)	CU NIPDAU	Level-1-260C-UNLIM
TPS3809K33DBVRG4	ACTIVE	SOT-23	DBV	3	3000	Green (RoHS & no Sb/Br)	CU NIPDAU	Level-1-260C-UNLIM
TPS3809K33DBVT	ACTIVE	SOT-23	DBV	3	250	Green (RoHS & no Sb/Br)	CU NIPDAU	Level-1-260C-UNLIM
TPS3809K33DBVTG4	ACTIVE	SOT-23	DBV	3	250	Green (RoHS & no Sb/Br)	CU NIPDAU	Level-1-260C-UNLIM
TPS3809L30DBVR	ACTIVE	SOT-23	DBV	3	3000	Green (RoHS & no Sb/Br)	CU NIPDAU	Level-1-260C-UNLIM
TPS3809L30DBVRG4	ACTIVE	SOT-23	DBV	3	3000	Green (RoHS & no Sb/Br)	CU NIPDAU	Level-1-260C-UNLIM
TPS3809L30DBVT	ACTIVE	SOT-23	DBV	3	250	Green (RoHS & no Sb/Br)	CU NIPDAU	Level-1-260C-UNLIM
TPS3809L30DBVTG4	ACTIVE	SOT-23	DBV	3	250	Green (RoHS & no Sb/Br)	CU NIPDAU	Level-1-260C-UNLIM

<sup>(1)</sup> The marketing status values are defined as follows:

**ACTIVE:** Product device recommended for new designs.

**LIFEBUY:** TI has announced that the device will be discontinued, and a lifetime-buy period is in effect.

**NRND:** Not recommended for new designs. Device is in production to support existing customers, but TI does not recommend using this part in a new design.

**PREVIEW:** Device has been announced but is not in production. Samples may or may not be available.

**OBSELETE:** TI has discontinued the production of the device.

<sup>(2)</sup> Eco Plan - The planned eco-friendly classification: Pb-Free (RoHS) or Green (RoHS & no Sb/Br) - please check <http://www.ti.com/productcontent> for the latest availability information and additional product content details.

**TBD:** The Pb-Free/Green conversion plan has not been defined.

**Pb-Free (RoHS):** TI's terms "Lead-Free" or "Pb-Free" mean semiconductor products that are compatible with the current RoHS requirements for all 6 substances, including the requirement that lead not exceed 0.1% by weight in homogeneous materials. Where designed to be soldered at high temperatures, TI Pb-Free products are suitable for use in specified lead-free processes.

**Green (RoHS & no Sb/Br):** TI defines "Green" to mean Pb-Free (RoHS compatible), and free of Bromine (Br) and Antimony (Sb) based flame retardants (Br or Sb do not exceed 0.1% by weight in homogeneous material)

<sup>(3)</sup> MSL, Peak Temp. -- The Moisture Sensitivity Level rating according to the JEDEC industry standard classifications, and peak solder temperature.

**Important Information and Disclaimer:** The information provided on this page represents TI's knowledge and belief as of the date that it is provided. TI bases its knowledge and belief on information provided by third parties, and makes no representation or warranty as to the