

## 3-Pin Supply Voltage Supervisors

Check for Samples: [TPS3809J25](#), [TPS3809L30](#), [TPS3809K33](#), [TPS3809I50](#)

### FEATURES

- 3-Pin SOT-23 Package
- Supply Current of 9  $\mu\text{A}$  (Typical)
- Precision Supply Voltage Monitor  
2.5 V, 3 V, 3.3 V, 5 V
- Pin-For-Pin Compatible With MAX 809
- Temperature Range:  $-40^{\circ}\text{C}$  to  $+85^{\circ}\text{C}$

### APPLICATIONS

- Applications Using DSPs, Microcontrollers, or Microprocessors
- Wireless Communication Systems
- Portable/Battery-Powered Equipment
- Programmable Controls
- Intelligent Instruments
- Industrial Equipment
- Notebook/Desktop Computers
- Automotive Systems

### DESCRIPTION

The TPS3809 family of supervisory circuits provides circuit initialization and timing supervision, primarily for DSPs and processor-based systems.

During power-on,  $\overline{\text{RESET}}$  is asserted when the supply voltage  $V_{\text{DD}}$  becomes higher than 1.1 V. Thereafter, the supervisory circuit monitors  $V_{\text{DD}}$  and keeps  $\overline{\text{RESET}}$  active as long as  $V_{\text{DD}}$  remains below the threshold voltage  $V_{\text{IT}}$ . An internal timer delays the return of the output to the inactive state (high) to ensure proper system reset. The delay time,  $t_{\text{d(typ)}}$  = 200 ms, starts after  $V_{\text{DD}}$  has risen above the threshold voltage  $V_{\text{IT}}$ . When the supply voltage drops below the threshold voltage  $V_{\text{IT}}$ , the output becomes active (low) again. No external components are required. All the devices of this family have a fixed sense-threshold voltage  $V_{\text{IT}}$  set by an internal voltage divider.

The product spectrum is designed for supply voltages of 2.5 V, 3 V, 3.3 V, and 5 V. The circuits are available in a 3-pin SOT-23. The TPS3809 devices are characterized for operation over a temperature range of  $-40^{\circ}\text{C}$  to  $85^{\circ}\text{C}$ .

DBV PACKAGE  
TOP VIEW)

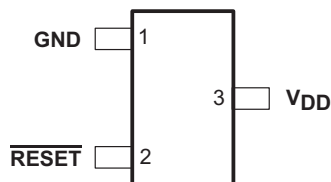

TYPICAL APPLICATION

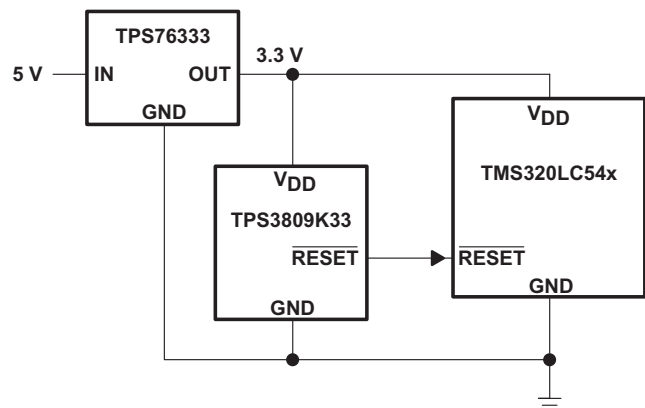

Please be aware that an important notice concerning availability, standard warranty, and use in critical applications of Texas Instruments semiconductor products and disclaimers thereto appears at the end of this data sheet.

All trademarks are the property of their respective owners.



These devices have limited built-in ESD protection. The leads should be shorted together or the device placed in conductive foam during storage or handling to prevent electrostatic damage to the MOS gates.

### AVAILABLE OPTIONS<sup>(1)</sup>

T <sub>A</sub>	DEVICE NAME		THRESHOLD VOLTAGE	MARKING
–40°C to 85°C	TPS3809J25DBVR	TPS3809J25DBVT	2.25 V	PCZI
	TPS3809L30DBVR	TPS3809L30DBVT	2.64 V	PDAI
	TPS3809K33DBVR	TPS3809K33DBVT	2.93 V	PDBI
	TPS3809I50DBVR	TPS3809I50DBVT	4.55 V	PDCI

(1) For the most current package and ordering information, see the Package Option Addendum at the end of this data sheet, or visit the device product folder at [www.ti.com](http://www.ti.com).

### FUNCTION/TRUTH TABLE, TPS3809

V <sub>DD</sub> >V <sub>IT</sub>	$\overline{\text{RESET}}$
0	L
1	H

### ORDERING INFORMATION

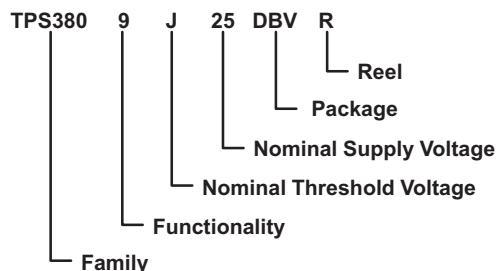

### ABSOLUTE MAXIMUM RATINGS<sup>(1)(2)</sup>

Over operating free-air temperature range (unless otherwise noted).

	UNIT
Supply voltage, V <sub>DD</sub>	7 V
All other pins	–0.3 V to 7 V
Maximum low-output current, I <sub>OL</sub>	5 mA
Maximum high-output current, I <sub>OH</sub>	–5 mA
Input-clamp current, I <sub>IK</sub> (V <sub>I</sub> < 0 or V <sub>I</sub> > V <sub>DD</sub> )	±20 mA
Output-clamp current, I <sub>OK</sub> (V <sub>O</sub> < 0 or V <sub>O</sub> > V <sub>DD</sub> )	±20 mA
Continuous total power dissipation	See Dissipation Rating Table
Operating free-air temperature range, T <sub>A</sub>	–40°C to 85°C
Storage temperature range, T <sub>stg</sub>	–65°C to 150°C

- Stresses beyond those listed under *absolute maximum ratings* may cause permanent damage to the device. These are stress ratings only, and functional operation of the device at these or any other conditions beyond those indicated under *recommended operating conditions* is not implied. Exposure to absolute-maximum-rated conditions for extended periods may affect device reliability.
- All voltage values are with respect to GND. For reliable operation, the device should not be operated at 7 V for more than t = 1000h continuously.

### DISSIPATION RATINGS

PACKAGE	T <sub>A</sub> < 25°C POWER RATING	DERATING FACTOR ABOVE T <sub>A</sub> < 25°C	T <sub>A</sub> = 70°C POWER RATING	T <sub>A</sub> = 85°C POWER RATING
DBV	437 mW	3.5 mW/°C	280 mW	227 mW

### RECOMMENDED OPERATING CONDITIONS

	MIN	MAX	UNIT
Supply voltage, V <sub>DD</sub>	2	6	V
$\overline{\text{RESET}}$ current sink during startup		50	μA
Operating free-air temperature range, T <sub>A</sub>	–40	+85	°C

## ELECTRICAL CHARACTERISTICS

Over recommended operating free-air temperature range (unless otherwise noted).

PARAMETER		TEST CONDITIONS	TPS3800-xx, TPS3801-xx, TPS3802-xx			UNIT	
			MIN	TYP	MAX		
V <sub>OH</sub>	High-level output voltage	V <sub>DD</sub> = 2.5 V to 6 V I <sub>OH</sub> = -500 μA	V <sub>DD</sub> -0.2			V	
		V <sub>DD</sub> = 3.3 V I <sub>OH</sub> = -2 mA	V <sub>DD</sub> -0.4				
		V <sub>DD</sub> = 6 V I <sub>OH</sub> = -4 mA	V <sub>DD</sub> -0.4				
V <sub>OL</sub>	Low-level output voltage	V <sub>DD</sub> = 2 V to 6 V, I <sub>OL</sub> = 500 μA	0.2			V	
		V <sub>DD</sub> = 3.3 V, I <sub>OL</sub> = 2 mA	0.4				
		V <sub>DD</sub> = 6 V, I <sub>OL</sub> = 4 mA	0.4				
Power-up reset voltage <sup>(1)</sup>		V <sub>DD</sub> ≥ 1.1 V, I <sub>OL</sub> = 50 μA	0.2			V	
V <sub>IT-</sub>	Negative-going input threshold voltage <sup>(2)</sup>	T <sub>A</sub> = -40°C to 85°C	TPS3809J25	2.2	2.25	2.3	V
			TPS3809L30	2.58	2.64	2.7	
			TPS3809K33	2.87	2.93	2.99	
			TPS3809I50	4.45	4.55	4.65	
V <sub>hys</sub>	Threshold hysteresis		TPS3809J25	30		mV	
			TPS3809L30	35			
			TPS3809K33	40			
			TPS3809I50	60			
I <sub>DD</sub>	Supply current	V <sub>DD</sub> = 2 V, output unconnected	9		12	μA	
		V <sub>DD</sub> = 6 V, output unconnected	20		25		
C <sub>i</sub>	Input capacitance	V <sub>I</sub> = 0 V to V <sub>DD</sub>	5			pF	

(1) The lowest supply voltage at which  $\overline{\text{RESET}}$  becomes active.  $t_r, V_{DD} \geq 15 \mu\text{s/V}$ .

(2) To ensure the best stability of the threshold voltage, a bypass capacitor (0.1-μF ceramic) should be placed near the supply terminals.

## TIMING REQUIREMENTS

at R<sub>L</sub> = 1 MΩ, C<sub>L</sub> = 50 pF, T<sub>A</sub> = 25°C

PARAMETER		TEST CONDITIONS	MIN	TYP	MAX	UNIT	
t <sub>w</sub>	Pulse width	at V <sub>DD</sub>	V <sub>DD</sub> = V <sub>IT-</sub> + 0.2 V, V <sub>DD</sub> = V <sub>IT-</sub> - 0.2 V			3	μs

## SWITCHING CHARACTERISTICS

at R<sub>L</sub> = 1 MΩ, C<sub>L</sub> = 50 pF, T<sub>A</sub> = 25°C

PARAMETER		TEST CONDITIONS	MIN	TYP	MAX	UNIT
t <sub>d</sub>	Delay time	V <sub>DD</sub> ≥ V <sub>IT-</sub> + 0.2 V, See <a href="#">timing diagram</a>	120	200	280	ms
t <sub>PHL</sub>	Propagation (delay) time, high-to-low-level output	V <sub>DD</sub> to $\overline{\text{RESET}}$ delay V <sub>IL</sub> = V <sub>IT-</sub> - 0.2 V, V <sub>IH</sub> = V <sub>IT-</sub> + 0.2 V	1			μs

**TIMING DIAGRAM**

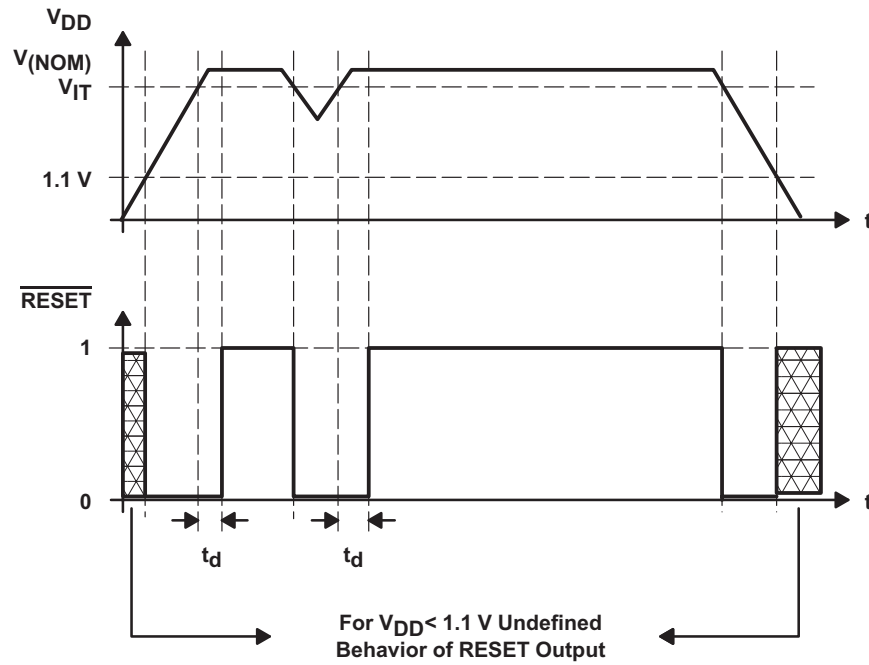

**FUNCTIONAL BLOCK DIAGRAM**

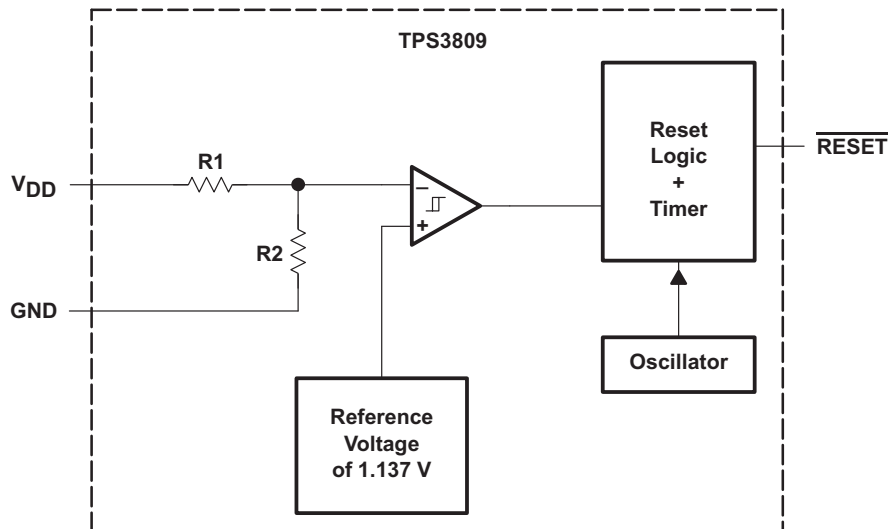

TYPICAL CHARACTERISTICS

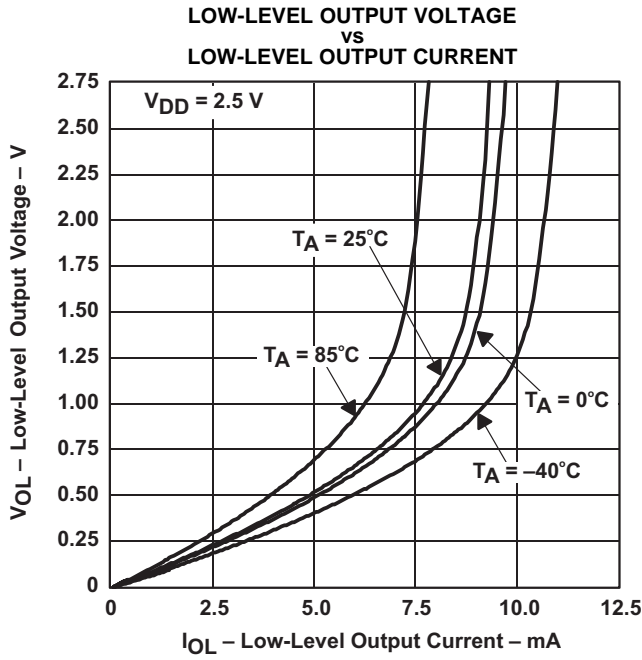

Figure 1.

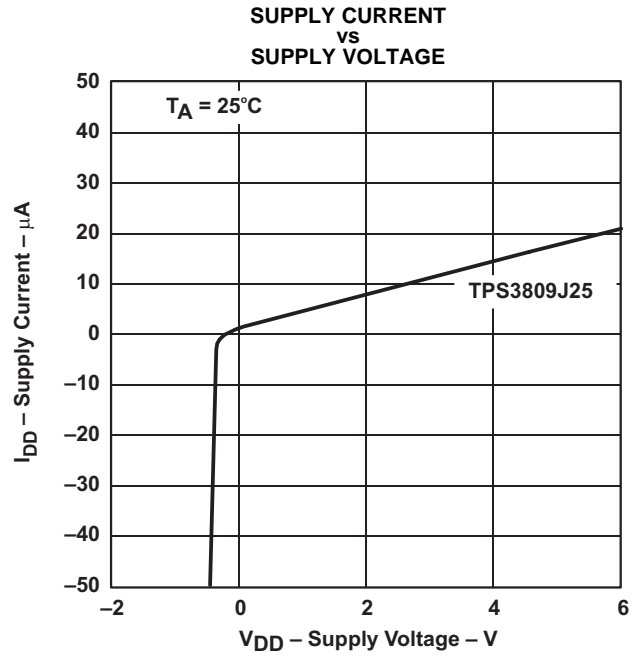

Figure 2.

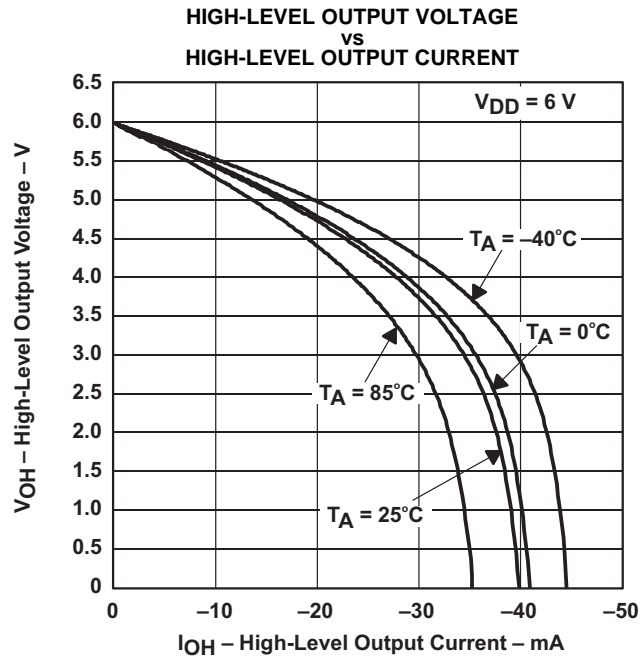

Figure 3.

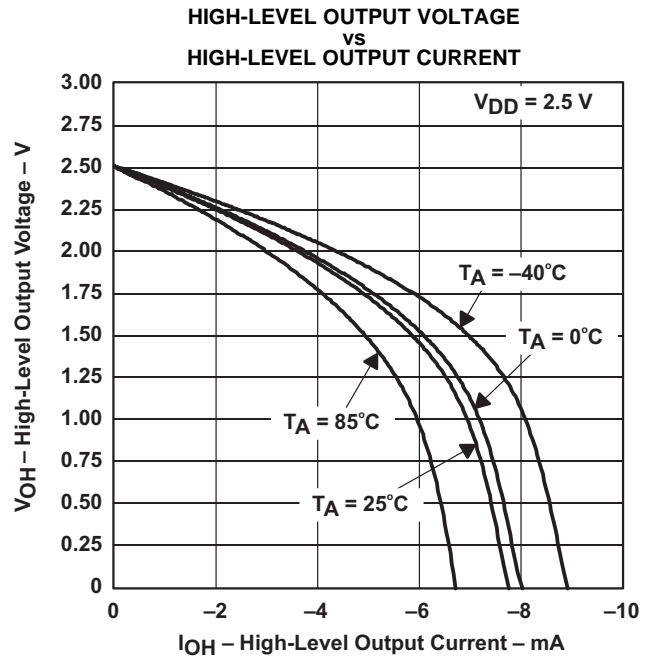

Figure 4.

**TYPICAL CHARACTERISTICS (continued)**

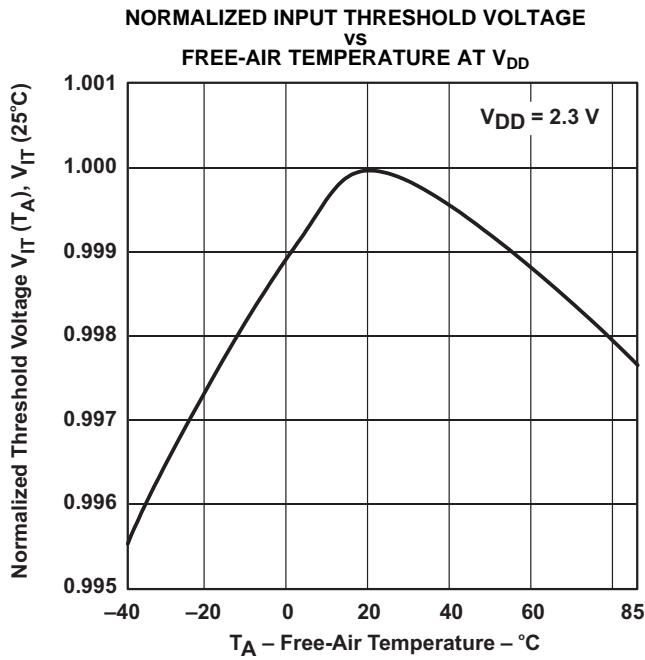

Figure 5.

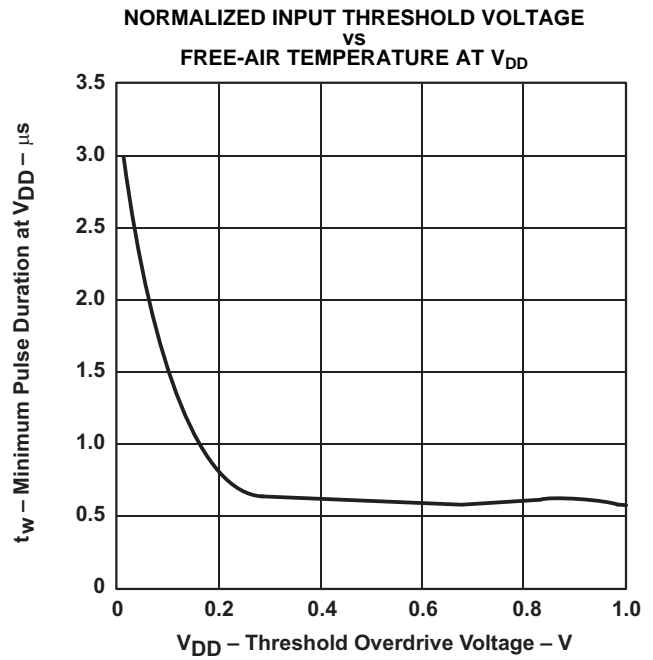

Figure 6.

**REVISION HISTORY**

NOTE: Page numbers for previous revisions may differ from page numbers in the current version.

Changes from Revision B (July 2012) to Revision C	Page
• Changed front page and page flow to match current standard look and feel .....	1
• Changed "Operating junction temperature range" to "Operating free-air temperature range" in Absolute Maximum Ratings (typo) .....	2
Changes from Revision A (October 2010) to Revision B	Page
• Changed the Pull-up resistor value, $\overline{\text{RESET}}$ To: $\overline{\text{RESET}}$ current sink during startup in the Recommended Operating Conditions Table .....	2
Changes from Original (August 1999) to Revision A	Page
• Added Pull-up resistor value, $\overline{\text{RESET}}$ to the Recommended Operating Conditions Table .....	2

**PACKAGING INFORMATION**

Orderable Device	Status (1)	Package Type	Package Drawing	Pins	Package Qty	Eco Plan (2)	Lead/Ball Finish (6)	MSL Peak Temp (3)	Op Temp (°C)	Device Marking (4/5)	Samples
TPS3809I50DBVR	ACTIVE	SOT-23	DBV	3	3000	Green (RoHS & no Sb/Br)	CU NIPDAU   Call TI	Level-1-260C-UNLIM	-40 to 85	PDCI	<a href="#">Samples</a>
TPS3809I50DBVRG4	ACTIVE	SOT-23	DBV	3	3000	Green (RoHS & no Sb/Br)	CU NIPDAU	Level-1-260C-UNLIM	-40 to 85	PDCI	<a href="#">Samples</a>
TPS3809I50DBVT	ACTIVE	SOT-23	DBV	3	250	Green (RoHS & no Sb/Br)	CU NIPDAU   Call TI	Level-1-260C-UNLIM	-40 to 85	PDCI	<a href="#">Samples</a>
TPS3809I50DBVTG4	ACTIVE	SOT-23	DBV	3	250	Green (RoHS & no Sb/Br)	CU NIPDAU	Level-1-260C-UNLIM	-40 to 85	PDCI	<a href="#">Samples</a>
TPS3809J25DBVR	ACTIVE	SOT-23	DBV	3	3000	Green (RoHS & no Sb/Br)	CU NIPDAU	Level-1-260C-UNLIM	-40 to 85	PCZI	<a href="#">Samples</a>
TPS3809J25DBVRG4	ACTIVE	SOT-23	DBV	3	3000	Green (RoHS & no Sb/Br)	CU NIPDAU	Level-1-260C-UNLIM	-40 to 85	PCZI	<a href="#">Samples</a>
TPS3809J25DBVT	ACTIVE	SOT-23	DBV	3	250	Green (RoHS & no Sb/Br)	CU NIPDAU	Level-1-260C-UNLIM	-40 to 85	PCZI	<a href="#">Samples</a>
TPS3809J25DBVTG4	ACTIVE	SOT-23	DBV	3	250	Green (RoHS & no Sb/Br)	CU NIPDAU	Level-1-260C-UNLIM	-40 to 85	PCZI	<a href="#">Samples</a>
TPS3809K33DBVR	ACTIVE	SOT-23	DBV	3	3000	Green (RoHS & no Sb/Br)	CU NIPDAU	Level-1-260C-UNLIM	-40 to 85	PDBI	<a href="#">Samples</a>
TPS3809K33DBVRG4	ACTIVE	SOT-23	DBV	3	3000	Green (RoHS & no Sb/Br)	CU NIPDAU	Level-1-260C-UNLIM	-40 to 85	PDBI	<a href="#">Samples</a>
TPS3809K33DBVT	ACTIVE	SOT-23	DBV	3	250	Green (RoHS & no Sb/Br)	CU NIPDAU	Level-1-260C-UNLIM	-40 to 85	PDBI	<a href="#">Samples</a>
TPS3809K33DBVTG4	ACTIVE	SOT-23	DBV	3	250	Green (RoHS & no Sb/Br)	CU NIPDAU	Level-1-260C-UNLIM	-40 to 85	PDBI	<a href="#">Samples</a>
TPS3809L30DBVR	ACTIVE	SOT-23	DBV	3	3000	Green (RoHS & no Sb/Br)	CU NIPDAU	Level-1-260C-UNLIM	-40 to 85	PDAI	<a href="#">Samples</a>
TPS3809L30DBVRG4	ACTIVE	SOT-23	DBV	3	3000	Green (RoHS & no Sb/Br)	CU NIPDAU	Level-1-260C-UNLIM	-40 to 85	PDAI	<a href="#">Samples</a>
TPS3809L30DBVT	ACTIVE	SOT-23	DBV	3	250	Green (RoHS & no Sb/Br)	CU NIPDAU	Level-1-260C-UNLIM	-40 to 85	PDAI	<a href="#">Samples</a>
TPS3809L30DBVTG4	ACTIVE	SOT-23	DBV	3	250	Green (RoHS & no Sb/Br)	CU NIPDAU	Level-1-260C-UNLIM	-40 to 85	PDAI	<a href="#">Samples</a>

(1) The marketing status values are defined as follows:  
**ACTIVE:** Product device recommended for new designs.

**LIFEBUY:** TI has announced that the device will be discontinued, and a lifetime-buy period is in effect.

**NRND:** Not recommended for new designs. Device is in production to support existing customers, but TI does not recommend using this part in a new design.

**PREVIEW:** Device has been announced but is not in production. Samples may or may not be available.

**OBSOLETE:** TI has discontinued the production of the device.

<sup>(2)</sup> Eco Plan - The planned eco-friendly classification: Pb-Free (RoHS), Pb-Free (RoHS Exempt), or Green (RoHS & no Sb/Br) - please check <http://www.ti.com/productcontent> for the latest availability information and additional product content details.

**TBD:** The Pb-Free/Green conversion plan has not been defined.

**Pb-Free (RoHS):** TI's terms "Lead-Free" or "Pb-Free" mean semiconductor products that are compatible with the current RoHS requirements for all 6 substances, including the requirement that lead not exceed 0.1% by weight in homogeneous materials. Where designed to be soldered at high temperatures, TI Pb-Free products are suitable for use in specified lead-free processes.

**Pb-Free (RoHS Exempt):** This component has a RoHS exemption for either 1) lead-based flip-chip solder bumps used between the die and package, or 2) lead-based die adhesive used between the die and leadframe. The component is otherwise considered Pb-Free (RoHS compatible) as defined above.

**Green (RoHS & no Sb/Br):** TI defines "Green" to mean Pb-Free (RoHS compatible), and free of Bromine (Br) and Antimony (Sb) based flame retardants (Br or Sb do not exceed 0.1% by weight in homogeneous material)

<sup>(3)</sup> MSL, Peak Temp. - The Moisture Sensitivity Level rating according to the JEDEC industry standard classifications, and peak solder temperature.

<sup>(4)</sup> There may be additional marking, which relates to the logo, the lot trace code information, or the environmental category on the device.

<sup>(5)</sup> Multiple Device Markings will be inside parentheses. Only one Device Marking contained in parentheses and separated by a "~" will appear on a device. If a line is indented then it is a continuation of the previous line and the two combined represent the entire Device Marking for that device.

<sup>(6)</sup> Lead/Ball Finish - Orderable Devices may have multiple material finish options. Finish options are separated by a vertical ruled line. Lead/Ball Finish values may wrap to two lines if the finish value exceeds the maximum column width.

**Important Information and Disclaimer:** The information provided on this page represents TI's knowledge and belief as of the date that it is provided. TI bases its knowledge and belief on information provided by third parties, and makes no representation or warranty as to the accuracy of such information. Efforts are underway to better integrate information from third parties. TI has taken and continues to take reasonable steps to provide representative and accurate information but may not have conducted destructive testing or chemical analysis on incoming materials and chemicals. TI and TI suppliers consider certain information to be proprietary, and thus CAS numbers and other limited information may not be available for release.

In no event shall TI's liability arising out of such information exceed the total purchase price of the TI part(s) at issue in this document sold by TI to Customer on an annual basis.

**OTHER QUALIFIED VERSIONS OF TPS3809I50, TPS3809J25, TPS3809K33, TPS3809L30 :**

● Automotive: [TPS3809I50-Q1](#), [TPS3809J25-Q1](#), [TPS3809K33-Q1](#), [TPS3809L30-Q1](#)

● Enhanced Product: [TPS3809I50-EP](#), [TPS3809K33-EP](#), [TPS3809L30-EP](#)

NOTE: Qualified Version Definitions:

- Automotive - Q100 devices qualified for high-reliability automotive applications targeting zero defects
- Enhanced Product - Supports Defense, Aerospace and Medical Applications

## TAPE AND REEL INFORMATION

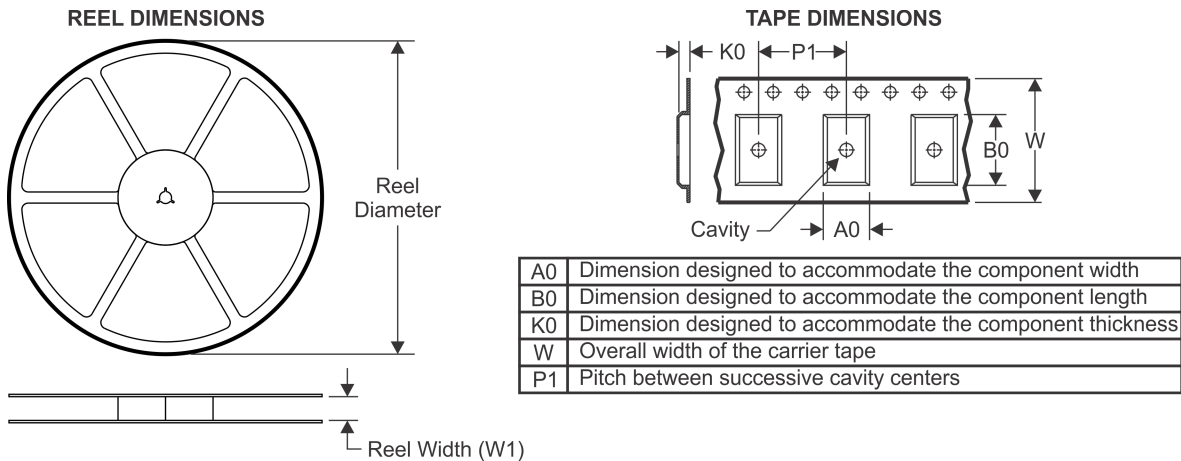

### QUADRANT ASSIGNMENTS FOR PIN 1 ORIENTATION IN TAPE

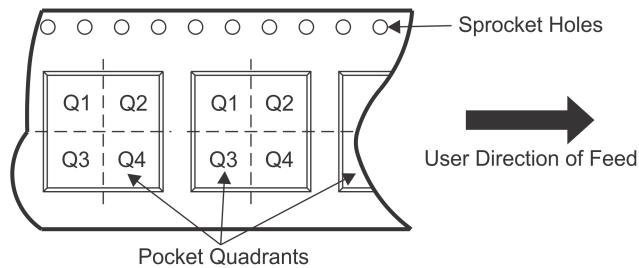

\*All dimensions are nominal

Device	Package Type	Package Drawing	Pins	SPQ	Reel Diameter (mm)	Reel Width W1 (mm)	A0 (mm)	B0 (mm)	K0 (mm)	P1 (mm)	W (mm)	Pin1 Quadrant
TPS3809I50DBVR	SOT-23	DBV	3	3000	178.0	9.0	3.3	3.2	1.47	4.0	8.0	Q3
TPS3809I50DBVT	SOT-23	DBV	3	250	178.0	9.0	3.3	3.2	1.47	4.0	8.0	Q3
TPS3809J25DBVR	SOT-23	DBV	3	3000	178.0	9.0	3.3	3.2	1.47	4.0	8.0	Q3
TPS3809J25DBVT	SOT-23	DBV	3	250	178.0	9.0	3.3	3.2	1.47	4.0	8.0	Q3
TPS3809K33DBVR	SOT-23	DBV	3	3000	178.0	9.0	3.3	3.2	1.47	4.0	8.0	Q3
TPS3809K33DBVT	SOT-23	DBV	3	3000	180.0	9.0	3.3	3.2	1.47	4.0	8.0	Q3
TPS3809K33DBVT	SOT-23	DBV	3	250	180.0	9.0	3.3	3.2	1.47	4.0	8.0	Q3
TPS3809K33DBVT	SOT-23	DBV	3	250	178.0	9.0	3.3	3.2	1.47	4.0	8.0	Q3
TPS3809L30DBVR	SOT-23	DBV	3	3000	180.0	9.0	3.3	3.2	1.47	4.0	8.0	Q3
TPS3809L30DBVT	SOT-23	DBV	3	3000	178.0	9.0	3.3	3.2	1.47	4.0	8.0	Q3
TPS3809L30DBVT	SOT-23	DBV	3	250	178.0	8.4	3.3	3.2	1.47	4.0	8.0	Q3
TPS3809L30DBVT	SOT-23	DBV	3	250	180.0	9.0	3.3	3.2	1.47	4.0	8.0	Q3

**TAPE AND REEL BOX DIMENSIONS**

\*All dimensions are nominal

Device	Package Type	Package Drawing	Pins	SPQ	Length (mm)	Width (mm)	Height (mm)
TPS3809I50DBVR	SOT-23	DBV	3	3000	180.0	180.0	18.0
TPS3809I50DBVT	SOT-23	DBV	3	250	180.0	180.0	18.0
TPS3809J25DBVR	SOT-23	DBV	3	3000	180.0	180.0	18.0
TPS3809J25DBVT	SOT-23	DBV	3	250	180.0	180.0	18.0
TPS3809K33DBVR	SOT-23	DBV	3	3000	180.0	180.0	18.0
TPS3809K33DBVR	SOT-23	DBV	3	3000	182.0	182.0	20.0
TPS3809K33DBVT	SOT-23	DBV	3	250	182.0	182.0	20.0
TPS3809K33DBVT	SOT-23	DBV	3	250	180.0	180.0	18.0
TPS3809L30DBVR	SOT-23	DBV	3	3000	182.0	182.0	20.0
TPS3809L30DBVR	SOT-23	DBV	3	3000	180.0	180.0	18.0
TPS3809L30DBVT	SOT-23	DBV	3	250	180.0	180.0	18.0
TPS3809L30DBVT	SOT-23	DBV	3	250	182.0	182.0	20.0

DBV (R-PDSO-G3)

PLASTIC SMALL-OUTLINE PACKAGE

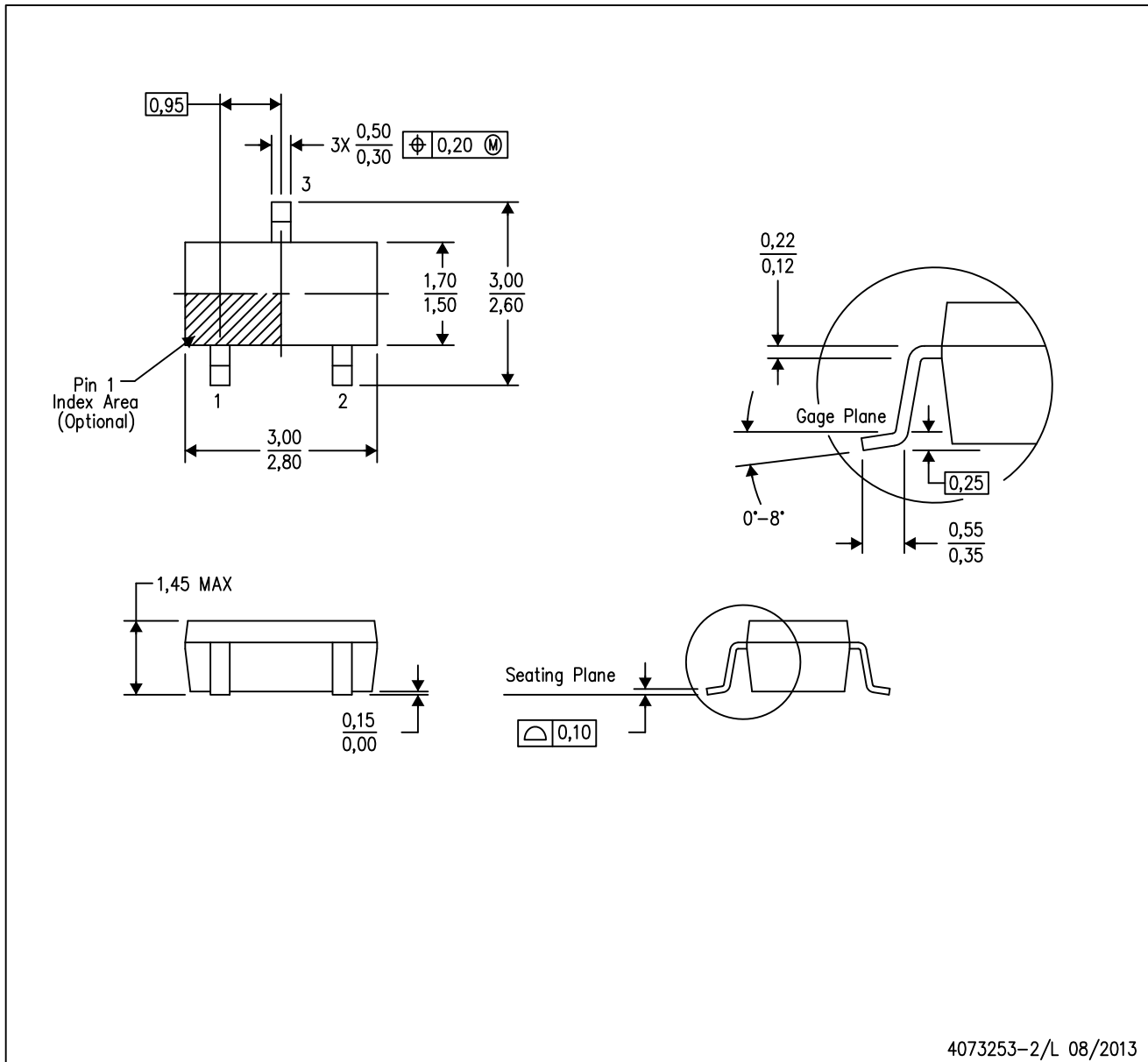

- NOTES:
- A. All linear dimensions are in millimeters.
  - B. This drawing is subject to change without notice.
  - C. Body dimensions do not include mold flash or protrusion. Mold flash and protrusion shall not exceed 0.15 per side.

DBV (R-PDSO-G3)

PLASTIC SMALL OUTLINE

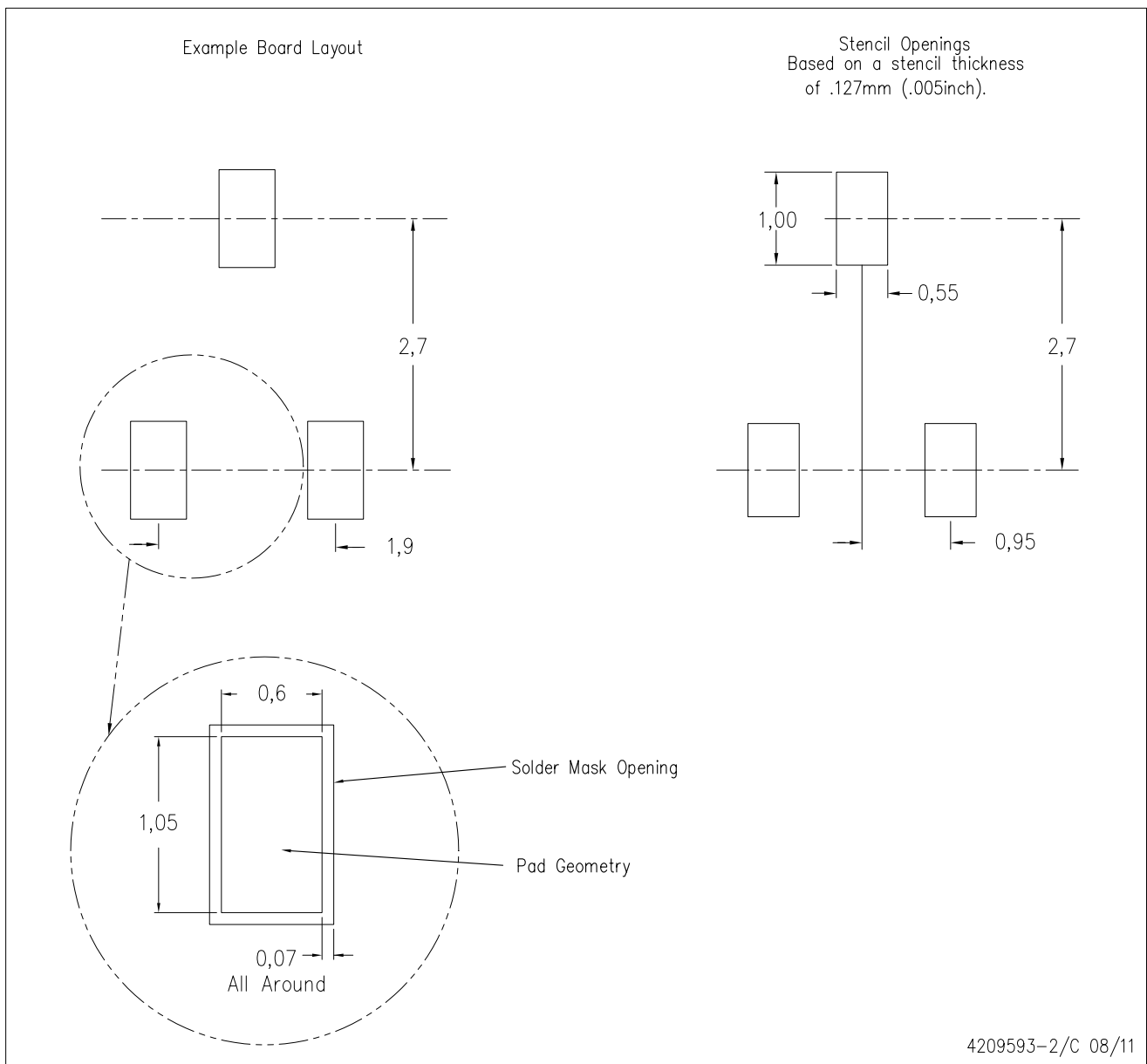

- NOTES:
- A. All linear dimensions are in millimeters.
  - B. This drawing is subject to change without notice.
  - C. Customers should place a note on the circuit board fabrication drawing not to alter the center solder mask defined pad.
  - D. Publication IPC-7351 is recommended for alternate designs.
  - E. Laser cutting apertures with trapezoidal walls and also rounding corners will offer better paste release. Customers should contact their board assembly site for stencil design recommendations. Example stencil design based on a 50% volumetric metal load solder paste. Refer to IPC-7525 for other stencil recommendations.

## IMPORTANT NOTICE

Texas Instruments Incorporated and its subsidiaries (TI) reserve the right to make corrections, enhancements, improvements and other changes to its semiconductor products and services per JESD46, latest issue, and to discontinue any product or service per JESD48, latest issue. Buyers should obtain the latest relevant information before placing orders and should verify that such information is current and complete. All semiconductor products (also referred to herein as "components") are sold subject to TI's terms and conditions of sale supplied at the time of order acknowledgment.

TI warrants performance of its components to the specifications applicable at the time of sale, in accordance with the warranty in TI's terms and conditions of sale of semiconductor products. Testing and other quality control techniques are used to the extent TI deems necessary to support this warranty. Except where mandated by applicable law, testing of all parameters of each component is not necessarily performed.

TI assumes no liability for applications assistance or the design of Buyers' products. Buyers are responsible for their products and applications using TI components. To minimize the risks associated with Buyers' products and applications, Buyers should provide adequate design and operating safeguards.

TI does not warrant or represent that any license, either express or implied, is granted under any patent right, copyright, mask work right, or other intellectual property right relating to any combination, machine, or process in which TI components or services are used. Information published by TI regarding third-party products or services does not constitute a license to use such products or services or a warranty or endorsement thereof. Use of such information may require a license from a third party under the patents or other intellectual property of the third party, or a license from TI under the patents or other intellectual property of TI.

Reproduction of significant portions of TI information in TI data books or data sheets is permissible only if reproduction is without alteration and is accompanied by all associated warranties, conditions, limitations, and notices. TI is not responsible or liable for such altered documentation. Information of third parties may be subject to additional restrictions.

Resale of TI components or services with statements different from or beyond the parameters stated by TI for that component or service voids all express and any implied warranties for the associated TI component or service and is an unfair and deceptive business practice. TI is not responsible or liable for any such statements.

Buyer acknowledges and agrees that it is solely responsible for compliance with all legal, regulatory and safety-related requirements concerning its products, and any use of TI components in its applications, notwithstanding any applications-related information or support that may be provided by TI. Buyer represents and agrees that it has all the necessary expertise to create and implement safeguards which anticipate dangerous consequences of failures, monitor failures and their consequences, lessen the likelihood of failures that might cause harm and take appropriate remedial actions. Buyer will fully indemnify TI and its representatives against any damages arising out of the use of any TI components in safety-critical applications.

In some cases, TI components may be promoted specifically to facilitate safety-related applications. With such components, TI's goal is to help enable customers to design and create their own end-product solutions that meet applicable functional safety standards and requirements. Nonetheless, such components are subject to these terms.

No TI components are authorized for use in FDA Class III (or similar life-critical medical equipment) unless authorized officers of the parties have executed a special agreement specifically governing such use.

Only those TI components which TI has specifically designated as military grade or "enhanced plastic" are designed and intended for use in military/aerospace applications or environments. Buyer acknowledges and agrees that any military or aerospace use of TI components which have **not** been so designated is solely at the Buyer's risk, and that Buyer is solely responsible for compliance with all legal and regulatory requirements in connection with such use.

TI has specifically designated certain components as meeting ISO/TS16949 requirements, mainly for automotive use. In any case of use of non-designated products, TI will not be responsible for any failure to meet ISO/TS16949.

### Products

Audio	<a href="http://www.ti.com/audio">www.ti.com/audio</a>
Amplifiers	<a href="http://amplifier.ti.com">amplifier.ti.com</a>
Data Converters	<a href="http://dataconverter.ti.com">dataconverter.ti.com</a>
DLP® Products	<a href="http://www.dlp.com">www.dlp.com</a>
DSP	<a href="http://dsp.ti.com">dsp.ti.com</a>
Clocks and Timers	<a href="http://www.ti.com/clocks">www.ti.com/clocks</a>
Interface	<a href="http://interface.ti.com">interface.ti.com</a>
Logic	<a href="http://logic.ti.com">logic.ti.com</a>
Power Mgmt	<a href="http://power.ti.com">power.ti.com</a>
Microcontrollers	<a href="http://microcontroller.ti.com">microcontroller.ti.com</a>
RFID	<a href="http://www.ti-rfid.com">www.ti-rfid.com</a>
OMAP Applications Processors	<a href="http://www.ti.com/omap">www.ti.com/omap</a>
Wireless Connectivity	<a href="http://www.ti.com/wirelessconnectivity">www.ti.com/wirelessconnectivity</a>

### Applications

Automotive and Transportation	<a href="http://www.ti.com/automotive">www.ti.com/automotive</a>
Communications and Telecom	<a href="http://www.ti.com/communications">www.ti.com/communications</a>
Computers and Peripherals	<a href="http://www.ti.com/computers">www.ti.com/computers</a>
Consumer Electronics	<a href="http://www.ti.com/consumer-apps">www.ti.com/consumer-apps</a>
Energy and Lighting	<a href="http://www.ti.com/energy">www.ti.com/energy</a>
Industrial	<a href="http://www.ti.com/industrial">www.ti.com/industrial</a>
Medical	<a href="http://www.ti.com/medical">www.ti.com/medical</a>
Security	<a href="http://www.ti.com/security">www.ti.com/security</a>
Space, Avionics and Defense	<a href="http://www.ti.com/space-avionics-defense">www.ti.com/space-avionics-defense</a>
Video and Imaging	<a href="http://www.ti.com/video">www.ti.com/video</a>

### TI E2E Community

[e2e.ti.com](http://e2e.ti.com)