



ULTRA-SMALL SUPPLY VOLTAGE SUPERVISORS

 Check for Samples: [TPS3800-xx](#), [TPS3801-xx](#), [TPS3802-xx](#)

FEATURES

- Small, 5-Pin SC-70 (SOT-323) Package
- Supply Current of 9 μ A
- Power-On Reset Generator With Fixed Delay Time
 - TPS3800 = 100 ms
 - TPS3801 = 200 ms
 - TPS3802 = 400 ms
- Precision Supply Voltage Monitor 1.8 V, 2.5 V, 2.7 V, 3 V, 3.3 V, 5 V, and Adjustable
- Manual Reset Input (Except TPS3801-01)
- Temperature Range: -40°C to $+85^{\circ}\text{C}$

APPLICATIONS

- Applications Using DSPs, Microcontrollers, or Microprocessors
- Wireless Communication Systems
- Portable/Battery-Powered Equipment
- Programmable Controls
- Intelligent Instruments
- Industrial Equipment
- Notebook/Desktop Computers
- Automotive Systems

DESCRIPTION

The TPS380x family of supervisory circuits monitor supply voltages to provide circuit initialization and timing supervision, primarily for DSPs and other processor-based systems.

These devices assert a push-pull $\overline{\text{RESET}}$ signal when the SENSE (adjustable version) or V_{DD} (fixed version) drops below a preset threshold. The $\overline{\text{RESET}}$ output remains asserted for the factory programmed delay time after the SENSE or V_{DD} return above its threshold.

The TPS380x devices, except the TPS3801-01, incorporate a manual reset input ($\overline{\text{MR}}$). A low level at $\overline{\text{MR}}$ causes $\overline{\text{RESET}}$ to become active.

The TPS380x uses a precision reference to achieve an overall threshold accuracy of 2%–2.5%. These devices are available in a 5-pin SC-70 package, which is only about half the size of a 5-pin SOT-23 package.

The TPS380x devices are fully specified over a temperature range of -40°C to $+85^{\circ}\text{C}$.

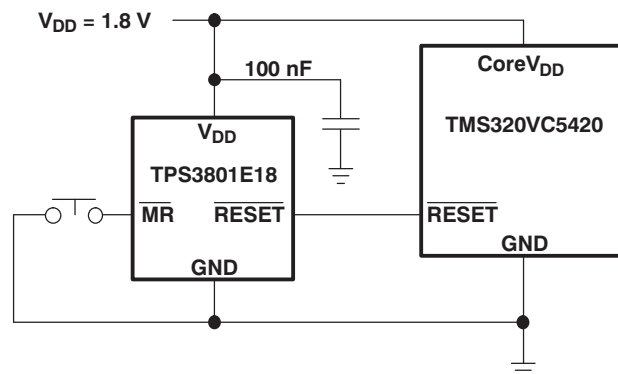
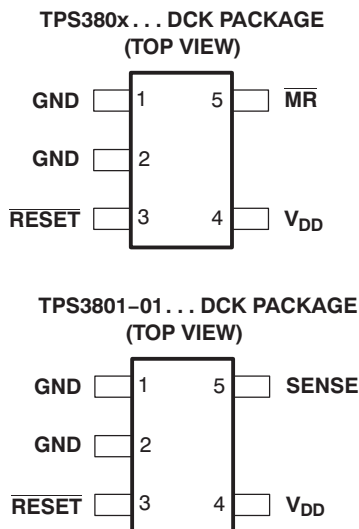

Please be aware that an important notice concerning availability, standard warranty, and use in critical applications of Texas Instruments semiconductor products and disclaimers thereto appears at the end of this data sheet.

All trademarks are the property of their respective owners.



These devices have limited built-in ESD protection. The leads should be shorted together or the device placed in conductive foam during storage or handling to prevent electrostatic damage to the MOS gates.

AVAILABLE OPTIONS⁽¹⁾

T _A	DEVICE NAME	THRESHOLD VOLTAGE	TYP DELAY TIME	MARKING
-40°C to 85°C	TPS3801-01DCK	Adjustable (V _{ref} = 1.14 V)	200 ms	ARF
	TPS3801E18DCK	1.71 V	200 ms	ARE
	TPS3801J25DCK	2.25 V	200 ms	NJA
	TPS3800G27DCK	2.5 V	95 ms	ARI
	TPS3801L30DCK	2.64 V	200 ms	NPA
	TPS3801K33DCK	2.93 V	200 ms	NWA
	TPS3802L30DCK	2.64 V	380 ms	ASA
	TPS3802K33DCK	2.93 V	380 ms	ARK
	TPS3801T50DCK	4.00 V	25 ms	AVI
	TPS3801I50DCK	4.55 V	200 ms	NSA

(1) For the most current package and ordering information, see the Package Option Addendum at the end of this data sheet, or refer to our web site at www.ti.com.

ABSOLUTE MAXIMUM RATINGS^{(1) (2)}

Over operating free-air temperature range (unless otherwise noted).

	UNIT
Supply voltage, V _{DD}	7 V
SENSE	-0.3 V to 5 V
All other pins	-0.3 V to 7 V
\overline{MR}	-0.3 V to V _{DD} + 0.3 V
\overline{RESET}	-0.3 V to V _{DD} + 0.3 V
Maximum low-output current, I _{OL}	5 mA
Maximum high-output current, I _{OH}	-5 mA
Input-clamp current, I _{IK} (V _I < 0 or V _I > V _{DD})	±20 mA
Output-clamp current, I _{OK} (V _O < 0 or V _O > V _{DD})	±20 mA
Operating junction temperature range, T _J ⁽³⁾	-40°C to +85°C
Storage temperature range, T _{stg}	-65°C to +150°C

(1) Stresses beyond those listed under *absolute maximum ratings* may cause permanent damage to the device. These are stress ratings only, and functional operation of the device at these or any other conditions beyond those indicated under *recommended operating conditions* is not implied. Exposure to absolute-maximum-rated conditions for extended periods may affect device reliability.

(2) All voltage values are with respect to GND. For reliable operation, the device should not be operated at 7 V for more than t = 1000h continuously.

(3) Due to the low dissipation power of this device, it is assumed that T_J = T_A.

RECOMMENDED OPERATING CONDITIONS

	MIN	MAX	UNIT	
Supply voltage, V _{DD}	TPS3801J25, TPS3801L30, TPS3801K33, TPS3801I50, TPS3801T50	2	6	V
	All other devices	1.6	4	
SENSE	0	See ⁽¹⁾	V	
Input voltage, V _I	0	V _{DD} + 0.3	V	
High-level input voltage, V _{IH}	0.7 × V _{DD}	V _{DD} + 0.3	V	
Low-level input voltage, V _{IL}		0.3 × V _{DD}	V	
Input transition rise and fall rate at \overline{MR} , Δt/ΔV		100	ns/V	
Pull-up resistor value, \overline{RESET}	V _{Pull-up} 50μA		Ω	
Operating free-air temperature range, T _A	-40	+85	°C	

(1) Maximum = V_{DD} + 0.3 or 4.5 V, whichever is greater.

ELECTRICAL CHARACTERISTICS

 Over -40°C to $+85^{\circ}\text{C}$ free-air temperature range (unless otherwise noted).

PARAMETER	TEST CONDITIONS	TPS3800-xx, TPS3801-xx, TPS3802-xx			UNIT	
		MIN	TYP	MAX		
V_{OH} High-level output voltage ($\overline{\text{RESET}}$)	$V_{DD} = 1.6\text{ V to }6\text{ V}$, $I_{OH} = -500\ \mu\text{A}$	$V_{DD} - 0.2$			V	
	$V_{DD} = 3.3\text{ V}$, $I_{OH} = -2\text{ mA}$	$V_{DD} - 0.4$				
	$V_{DD} = 6\text{ V}$, $I_{OH} = -4\text{ mA}$ ⁽¹⁾	$V_{DD} - 0.4$				
V_{OL} Low-level output voltage ($\overline{\text{RESET}}$)	$V_{DD} = 1.6\text{ V to }6\text{ V}$, $I_{OL} = 500\ \mu\text{A}$	0.2			V	
	$V_{DD} = 3.3\text{ V}$, $I_{OL} = 2\text{ mA}$	0.4				
	$V_{DD} = 6\text{ V}$, $I_{OL} = 4\text{ mA}$ ⁽¹⁾	0.4				
Power-up reset voltage ⁽²⁾	$V_{DD} \geq 1.1\text{ V}$, $I_{OL} = 50\ \mu\text{A}$	0.2			V	
V_{IT-} Negative-going input threshold voltage ⁽³⁾	TPS380x-01	$T_A = -40^{\circ}\text{C to }85^{\circ}\text{C}$	1.117	1.14	1.163	V
	TPS380xE18		1.67	1.71	1.75	
	TPS380xJ25		2.2	2.25	2.3	
	TPS380xG27		2.45	2.5	2.55	
	TPS380xL30		2.58	2.64	2.7	
	TPS380xK33		2.87	2.93	2.99	
	TPS380xI50		4.45	4.55	4.65	
	TPS380xT50		3.92	4	4.08	
V_{hys} Threshold hysteresis	TPS380x-01		15		mV	
	TPS380xx18		25			
	TPS380xx25		30			
	TPS380xx27		35			
	TPS380xx30		35			
	TPS380xx33		40			
	TPS380xx50		60			
I_{IH} High-level input current ($\overline{\text{MR}}$)	$\overline{\text{MR}} = 0.7 \times V_{DD}$, $V_{DD} = 6\text{ V}$	-40	-60	-100	μA	
I_{IL} Low-level input current ($\overline{\text{MR}}$)	$\overline{\text{MR}} = 0\text{ V}$, $V_{DD} = 6\text{ V}$	-130	-200	-340	μA	
I_I Input current (SENSE)		-25		25	nA	
I_{DD} Supply current	TPS3801J25, TPS3801L30, TPS3801K33, TPS3801I50, TPS3801T50	$V_{DD} = 2\text{ V}$, $\overline{\text{MR}}$ and output unconnected	9	12	μA	
		$V_{DD} = 6\text{ V}$, $\overline{\text{MR}}$ and output unconnected	20	25		
	TPS3801-01	$V_{DD} = 1.6\text{ V}$, SENSE = 0 V to V_{DD} , output unconnected	7	10		
		$V_{DD} = 4\text{ V}$, SENSE = 0 V to V_{DD} , output unconnected	9	12		
	TPS3801E18, TPS3800G27, TPS3802K33, TPS3802L30	$V_{DD} = 1.6\text{ V}$, $\overline{\text{MR}}$ and output unconnected	8	11		
$V_{DD} = 4\text{ V}$, $\overline{\text{MR}}$ and output unconnected		13	18			
C_i Input capacitance	$V_I = 0\text{ V to }V_{DD}$	5			pF	

(1) Only valid for the TPS3801J25, TPS3801L30, TPS3801K33, TPS3801I50, and TPS3801T50.

 (2) The lowest supply voltage at which $\overline{\text{RESET}}$ becomes active. t_r , $V_{DD} \geq 15\ \mu\text{s/V}$.

 (3) To ensure the best stability of the threshold voltage, a bypass capacitor (0.1- μF ceramic) should be placed near the supply terminals.

TIMING REQUIREMENTS

at $R_L = 1\text{ M}\Omega$, $C_L = 50\text{ pF}$, $T_A = +25^\circ\text{C}$

PARAMETER		TEST CONDITIONS	MIN	TYP	MAX	UNIT	
t_w	Pulse width	at SENSE	$V_{DD} = 1.6\text{ V}$, $V_{IH} = 1.1 \times V_{IT-}$, $V_{IL} = 0.9 \times V_{IT-}$			1	μs
		at V_{DD}	$V_{DD} = V_{IT-} + 0.2\text{ V}$, $V_{DD} = V_{IT-} - 0.2\text{ V}$			3	
		at $\overline{\text{MR}}$	$V_{DD} \geq V_{IT-} + 0.2\text{ V}$, $V_{IL} = 0.3 \times V_{DD}$, $V_{IH} = 0.7 \times V_{DD}$			100	ns

SWITCHING CHARACTERISTICS

at $R_L = 1\text{ M}\Omega$, $C_L = 50\text{ pF}$, $T_A = +25^\circ\text{C}$

PARAMETER		TEST CONDITIONS	MIN	TYP	MAX	UNIT	
t_d	$\overline{\text{RESET}}$ recovery delay time	TPS3801T50	15	25	35	ms	
		TPS3800	60	95	140		
		TPS3801	120	200	280		
		TPS3802	240	380	560		
t_{PHL}	Propagation (delay) time, high-to-low-level output	$\overline{\text{MR}}$ to $\overline{\text{RESET}}$ delay	$V_{DD} \geq V_{IT-} + 0.2\text{ V}$, $V_{IL} = 0.3 \times V_{DD}$, $V_{IH} = 0.7 \times V_{DD}$			15	ns
		V_{DD} to $\overline{\text{RESET}}$ delay	$V_{IL} = V_{IT-} - 0.2\text{ V}$, $V_{IH} = V_{IT-} + 0.2\text{ V}$			1	μs
		SENSE to $\overline{\text{RESET}}$	$V_{IL} = V_{IT-} - 0.2\text{ V}$, $V_{IH} = V_{IT-} + 0.2\text{ V}$			1	μs

TIMING DIAGRAM

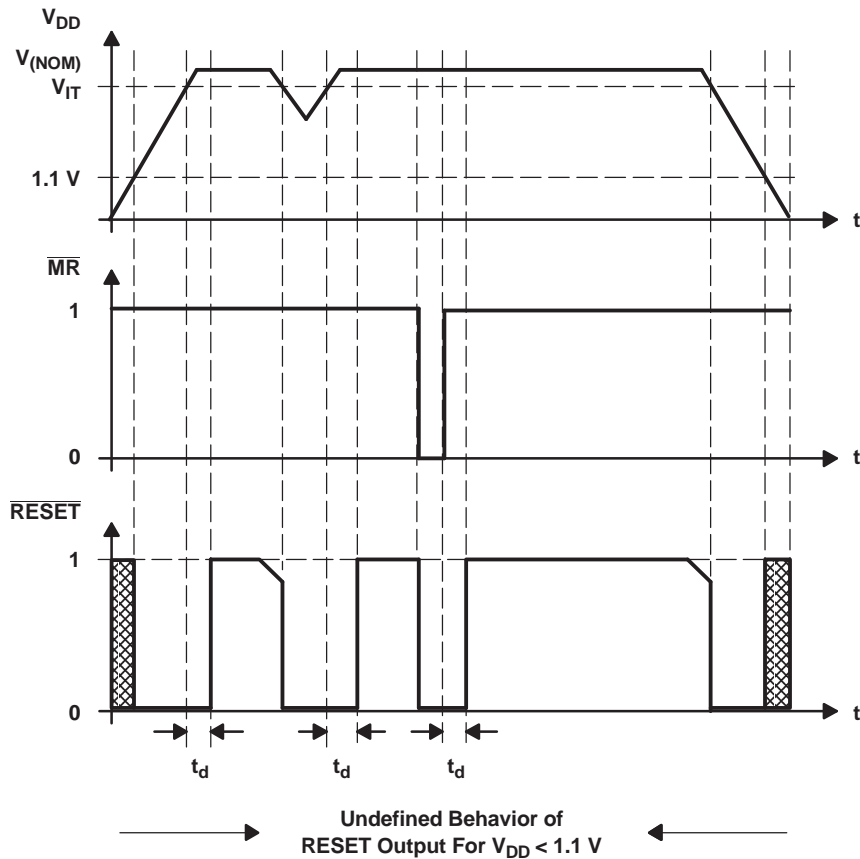

NOTE: $\overline{\text{RESET}}$ should not be forced high during the power-up sequence (until $V_{DD} > 1.1\text{ V}$).

FUNCTIONAL BLOCK DIAGRAMS

FUNCTION/TRUTH TABLE, TPS380x

MR	$V_{DD} > V_{IT}$	RESET
L	0	L
L	1	L
H	0	L
H	1	H

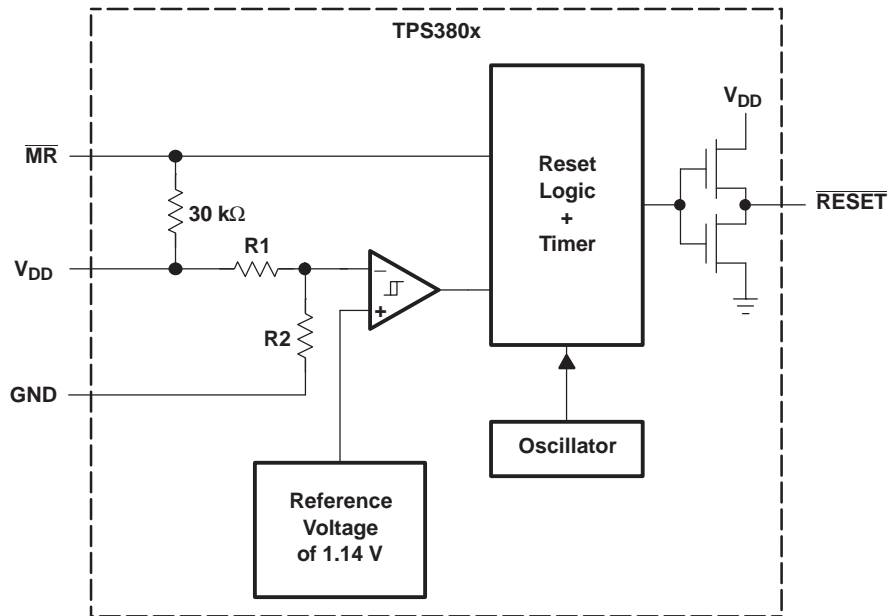

Figure 1.

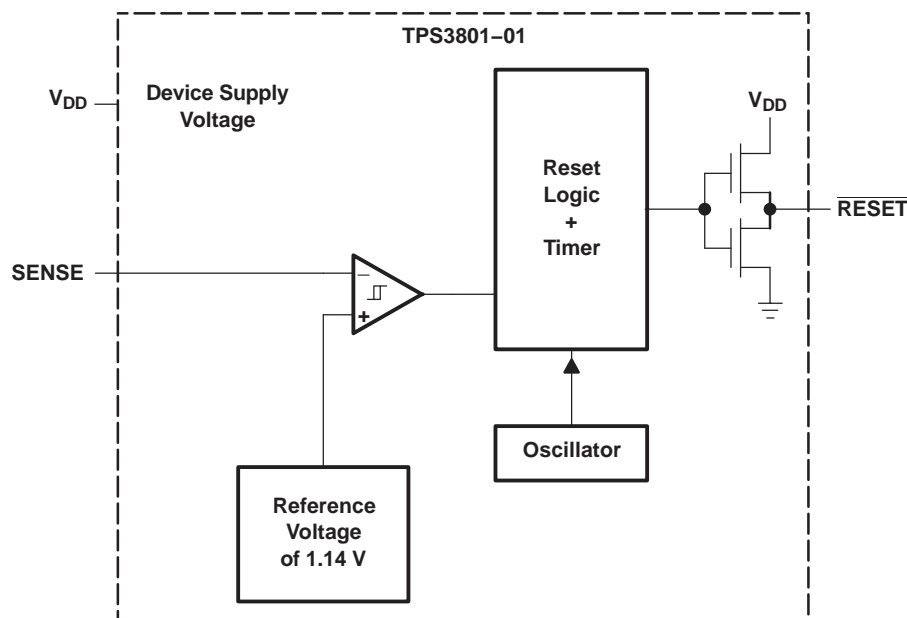

Figure 2.

TYPICAL CHARACTERISTICS

LOW-LEVEL OUTPUT VOLTAGE
 vs
 LOW-LEVEL OUTPUT CURRENT

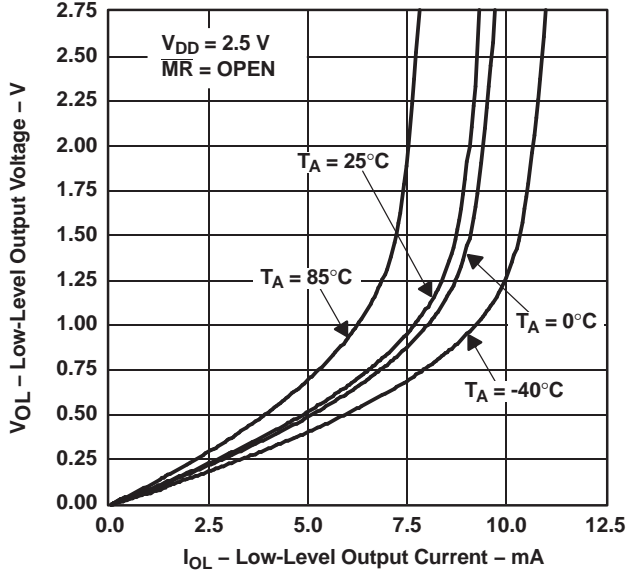

Figure 3.

SUPPLY CURRENT
 vs
 SUPPLY VOLTAGE

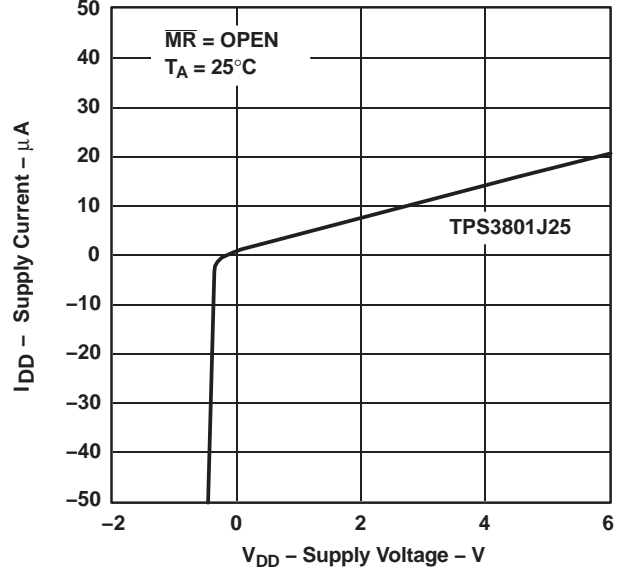

Figure 4.

HIGH-LEVEL OUTPUT VOLTAGE
 vs
 HIGH-LEVEL OUTPUT CURRENT

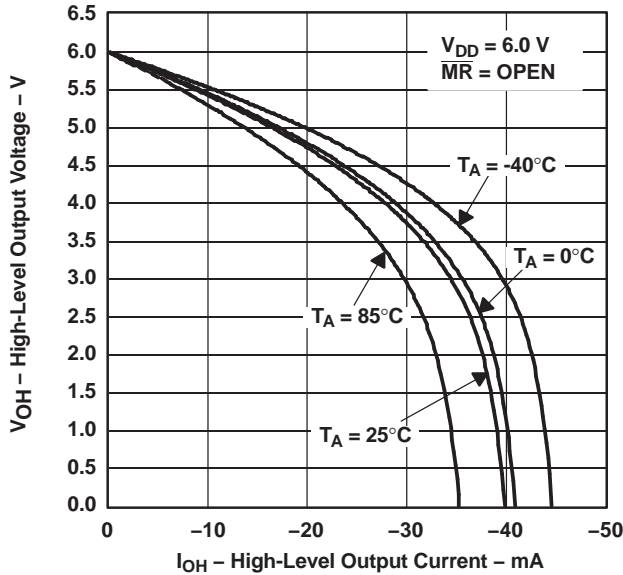

Figure 5.

HIGH-LEVEL OUTPUT VOLTAGE
 vs
 HIGH-LEVEL OUTPUT CURRENT

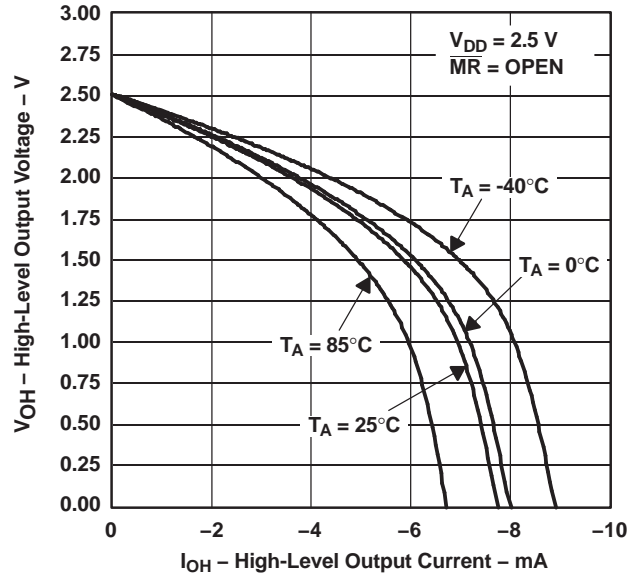
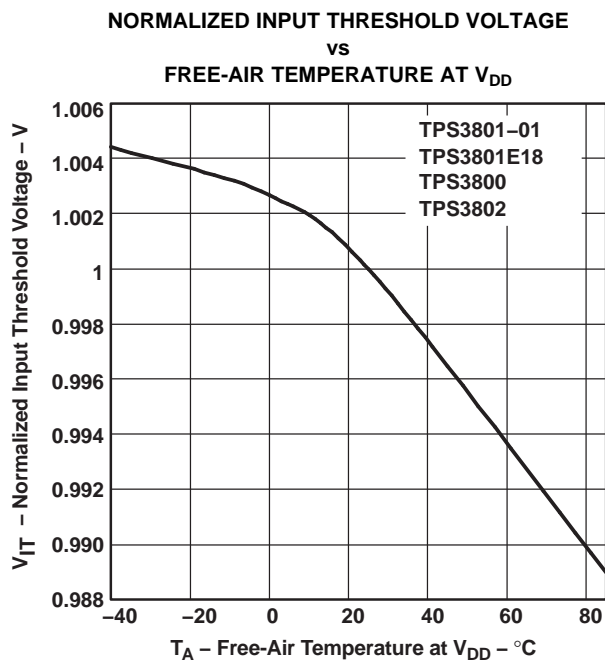
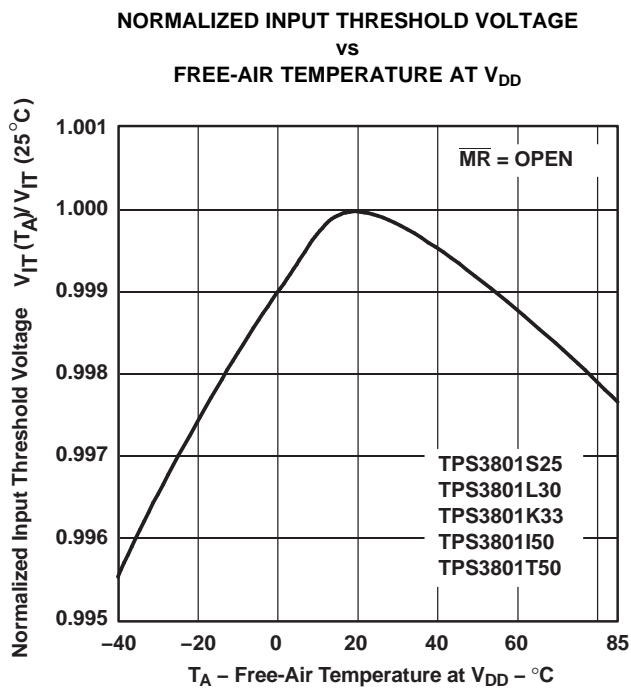
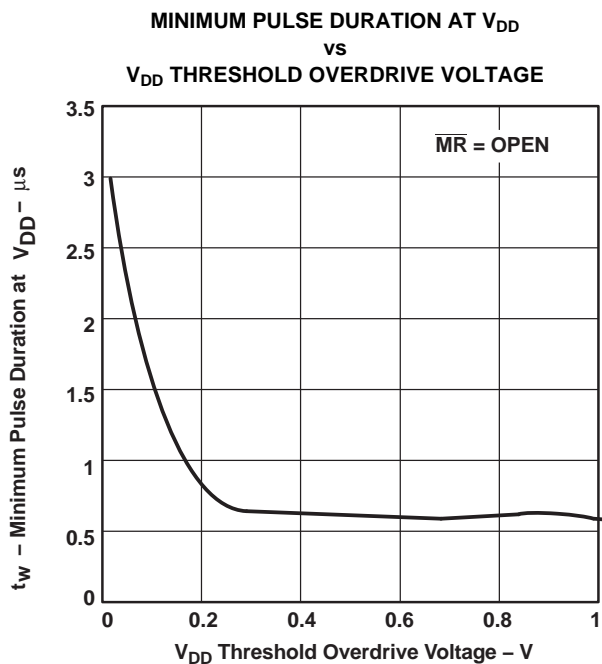
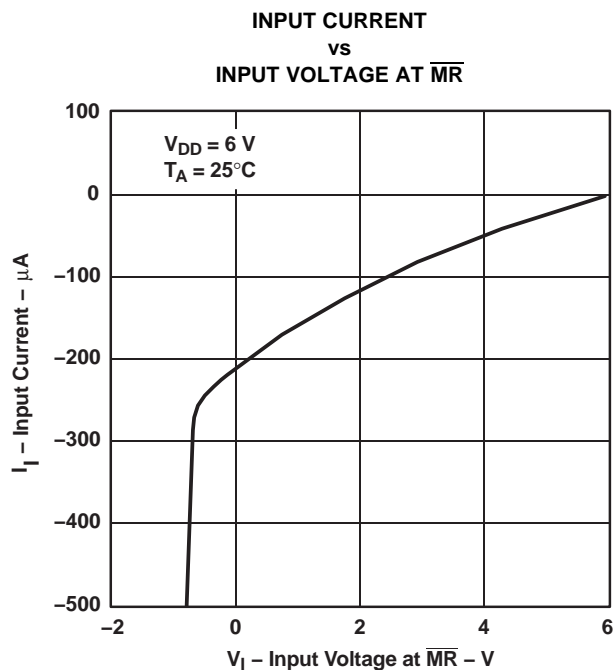

Figure 6.

TYPICAL CHARACTERISTICS (continued)



Changes from Revision D (December 2006) to Revision E

Page

-
- Added Pull-up resistor value, $\overline{\text{RESET}}$ to the Recommended Operating Conditions Table [2](#)
-

PACKAGING INFORMATION

Orderable Device	Status ⁽¹⁾	Package Type	Package Drawing	Pins	Package Qty	Eco Plan ⁽²⁾	Lead/ Ball Finish	MSL Peak Temp ⁽³⁾	Samples (Requires Login)
TPS3800G27DCKR	ACTIVE	SC70	DCK	5	3000	Green (RoHS & no Sb/Br)	CU NIPDAU	Level-1-260C-UNLIM	Request Free Samples
TPS3800G27DCKRG4	ACTIVE	SC70	DCK	5	3000	Green (RoHS & no Sb/Br)	CU NIPDAU	Level-1-260C-UNLIM	Request Free Samples
TPS3801-01DCKR	ACTIVE	SC70	DCK	5	3000	Green (RoHS & no Sb/Br)	CU NIPDAU	Level-1-260C-UNLIM	Request Free Samples
TPS3801-01DCKRG4	ACTIVE	SC70	DCK	5	3000	Green (RoHS & no Sb/Br)	CU NIPDAU	Level-1-260C-UNLIM	Request Free Samples
TPS3801E18DCKR	ACTIVE	SC70	DCK	5	3000	Green (RoHS & no Sb/Br)	CU NIPDAU	Level-1-260C-UNLIM	Request Free Samples
TPS3801E18DCKRG4	ACTIVE	SC70	DCK	5	3000	Green (RoHS & no Sb/Br)	CU NIPDAU	Level-1-260C-UNLIM	Request Free Samples
TPS3801I50DCKR	ACTIVE	SC70	DCK	5	3000	Green (RoHS & no Sb/Br)	CU NIPDAU	Level-1-260C-UNLIM	Request Free Samples
TPS3801I50DCKRG4	ACTIVE	SC70	DCK	5	3000	Green (RoHS & no Sb/Br)	CU NIPDAU	Level-1-260C-UNLIM	Request Free Samples
TPS3801J25DCKR	ACTIVE	SC70	DCK	5	3000	Green (RoHS & no Sb/Br)	CU NIPDAU	Level-1-260C-UNLIM	Request Free Samples
TPS3801J25DCKRG4	ACTIVE	SC70	DCK	5	3000	Green (RoHS & no Sb/Br)	CU NIPDAU	Level-1-260C-UNLIM	Request Free Samples
TPS3801K33DCKR	ACTIVE	SC70	DCK	5	3000	Green (RoHS & no Sb/Br)	CU NIPDAU	Level-1-260C-UNLIM	Request Free Samples
TPS3801K33DCKRG4	ACTIVE	SC70	DCK	5	3000	Green (RoHS & no Sb/Br)	CU NIPDAU	Level-1-260C-UNLIM	Request Free Samples
TPS3801L30DCKR	ACTIVE	SC70	DCK	5	3000	Green (RoHS & no Sb/Br)	CU NIPDAU	Level-1-260C-UNLIM	Request Free Samples
TPS3801L30DCKRG4	ACTIVE	SC70	DCK	5	3000	Green (RoHS & no Sb/Br)	CU NIPDAU	Level-1-260C-UNLIM	Request Free Samples
TPS3801T50DCKR	ACTIVE	SC70	DCK	5	3000	Green (RoHS & no Sb/Br)	CU NIPDAU	Level-1-260C-UNLIM	Request Free Samples
TPS3801T50DCKRG4	ACTIVE	SC70	DCK	5	3000	Green (RoHS & no Sb/Br)	CU NIPDAU	Level-1-260C-UNLIM	Request Free Samples
TPS3801T50DCKT	OBSOLETE	SC70	DCK	5		TBD	Call TI	Call TI	Samples Not Available

Orderable Device	Status ⁽¹⁾	Package Type	Package Drawing	Pins	Package Qty	Eco Plan ⁽²⁾	Lead/ Ball Finish	MSL Peak Temp ⁽³⁾	Samples (Requires Login)
TPS3802K33DCKR	ACTIVE	SC70	DCK	5	3000	Green (RoHS & no Sb/Br)	CU NIPDAU	Level-1-260C-UNLIM	Request Free Samples
TPS3802K33DCKRG4	ACTIVE	SC70	DCK	5	3000	Green (RoHS & no Sb/Br)	CU NIPDAU	Level-1-260C-UNLIM	Request Free Samples
TPS3802L30DCKR	ACTIVE	SC70	DCK	5	3000	Green (RoHS & no Sb/Br)	CU NIPDAU	Level-1-260C-UNLIM	Request Free Samples
TPS3802L30DCKRG4	ACTIVE	SC70	DCK	5	3000	Green (RoHS & no Sb/Br)	CU NIPDAU	Level-1-260C-UNLIM	Request Free Samples

⁽¹⁾ The marketing status values are defined as follows:

ACTIVE: Product device recommended for new designs.

LIFEBUY: TI has announced that the device will be discontinued, and a lifetime-buy period is in effect.

NRND: Not recommended for new designs. Device is in production to support existing customers, but TI does not recommend using this part in a new design.

PREVIEW: Device has been announced but is not in production. Samples may or may not be available.

OBSOLETE: TI has discontinued the production of the device.

⁽²⁾ Eco Plan - The planned eco-friendly classification: Pb-Free (RoHS), Pb-Free (RoHS Exempt), or Green (RoHS & no Sb/Br) - please check <http://www.ti.com/productcontent> for the latest availability information and additional product content details.

TBD: The Pb-Free/Green conversion plan has not been defined.

Pb-Free (RoHS): TI's terms "Lead-Free" or "Pb-Free" mean semiconductor products that are compatible with the current RoHS requirements for all 6 substances, including the requirement that lead not exceed 0.1% by weight in homogeneous materials. Where designed to be soldered at high temperatures, TI Pb-Free products are suitable for use in specified lead-free processes.

Pb-Free (RoHS Exempt): This component has a RoHS exemption for either 1) lead-based flip-chip solder bumps used between the die and package, or 2) lead-based die adhesive used between the die and leadframe. The component is otherwise considered Pb-Free (RoHS compatible) as defined above.

Green (RoHS & no Sb/Br): TI defines "Green" to mean Pb-Free (RoHS compatible), and free of Bromine (Br) and Antimony (Sb) based flame retardants (Br or Sb do not exceed 0.1% by weight in homogeneous material)

⁽³⁾ MSL, Peak Temp. -- The Moisture Sensitivity Level rating according to the JEDEC industry standard classifications, and peak solder temperature.

Important Information and Disclaimer: The information provided on this page represents TI's knowledge and belief as of the date that it is provided. TI bases its knowledge and belief on information provided by third parties, and makes no representation or warranty as to the accuracy of such information. Efforts are underway to better integrate information from third parties. TI has taken and continues to take reasonable steps to provide representative and accurate information but may not have conducted destructive testing or chemical analysis on incoming materials and chemicals. TI and TI suppliers consider certain information to be proprietary, and thus CAS numbers and other limited information may not be available for release.

In no event shall TI's liability arising out of such information exceed the total purchase price of the TI part(s) at issue in this document sold by TI to Customer on an annual basis.

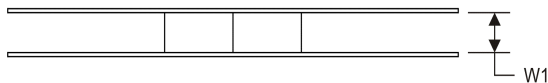
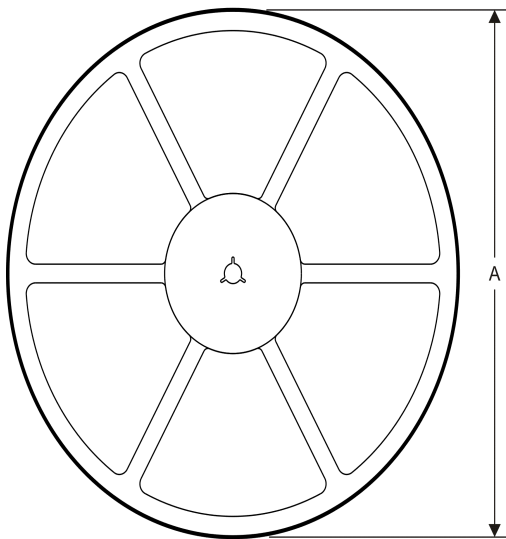
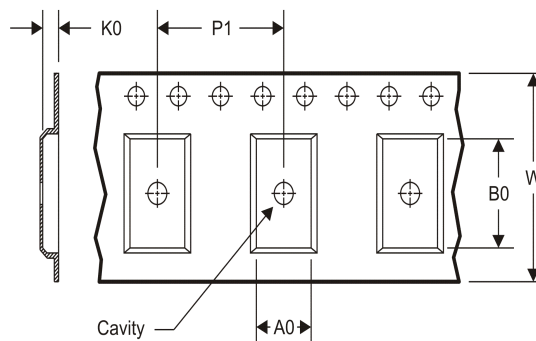
TAPE AND REEL INFORMATION
REEL DIMENSIONS

TAPE DIMENSIONS

A0	Dimension designed to accommodate the component width
B0	Dimension designed to accommodate the component length
K0	Dimension designed to accommodate the component thickness
W	Overall width of the carrier tape
P1	Pitch between successive cavity centers

TAPE AND REEL INFORMATION

*All dimensions are nominal

Device	Package Type	Package Drawing	Pins	SPQ	Reel Diameter (mm)	Reel Width W1 (mm)	A0 (mm)	B0 (mm)	K0 (mm)	P1 (mm)	W (mm)	Pin1 Quadrant
TPS3800G27DCKR	SC70	DCK	5	3000	178.0	9.0	2.4	2.5	1.2	4.0	8.0	Q3
TPS3800G27DCKR	SC70	DCK	5	3000	180.0	8.4	2.25	2.4	1.22	4.0	8.0	Q3
TPS3801-01DCKR	SC70	DCK	5	3000	180.0	8.4	2.25	2.4	1.22	4.0	8.0	Q3
TPS3801E18DCKR	SC70	DCK	5	3000	180.0	8.4	2.25	2.4	1.22	4.0	8.0	Q3
TPS3801E18DCKR	SC70	DCK	5	3000	178.0	9.0	2.4	2.5	1.2	4.0	8.0	Q3
TPS3801I50DCKR	SC70	DCK	5	3000	180.0	8.4	2.25	2.4	1.22	4.0	8.0	Q3
TPS3801J25DCKR	SC70	DCK	5	3000	180.0	8.4	2.25	2.4	1.22	4.0	8.0	Q3
TPS3801K33DCKR	SC70	DCK	5	3000	178.0	9.0	2.4	2.5	1.2	4.0	8.0	Q3
TPS3801K33DCKR	SC70	DCK	5	3000	180.0	8.4	2.25	2.4	1.22	4.0	8.0	Q3
TPS3801L30DCKR	SC70	DCK	5	3000	180.0	8.4	2.25	2.4	1.22	4.0	8.0	Q3
TPS3801T50DCKR	SC70	DCK	5	3000	178.0	9.0	2.4	2.5	1.2	4.0	8.0	Q3
TPS3801T50DCKR	SC70	DCK	5	3000	180.0	8.4	2.25	2.4	1.22	4.0	8.0	Q3
TPS3802K33DCKR	SC70	DCK	5	3000	180.0	8.4	2.25	2.4	1.22	4.0	8.0	Q3
TPS3802L30DCKR	SC70	DCK	5	3000	180.0	8.4	2.25	2.4	1.22	4.0	8.0	Q3

TAPE AND REEL BOX DIMENSIONS

*All dimensions are nominal

Device	Package Type	Package Drawing	Pins	SPQ	Length (mm)	Width (mm)	Height (mm)
TPS3800G27DCKR	SC70	DCK	5	3000	180.0	180.0	18.0
TPS3800G27DCKR	SC70	DCK	5	3000	202.0	201.0	28.0
TPS3801-01DCKR	SC70	DCK	5	3000	202.0	201.0	28.0
TPS3801E18DCKR	SC70	DCK	5	3000	202.0	201.0	28.0
TPS3801E18DCKR	SC70	DCK	5	3000	180.0	180.0	18.0
TPS3801I50DCKR	SC70	DCK	5	3000	202.0	201.0	28.0
TPS3801J25DCKR	SC70	DCK	5	3000	202.0	201.0	28.0
TPS3801K33DCKR	SC70	DCK	5	3000	180.0	180.0	18.0
TPS3801K33DCKR	SC70	DCK	5	3000	202.0	201.0	28.0
TPS3801L30DCKR	SC70	DCK	5	3000	202.0	201.0	28.0
TPS3801T50DCKR	SC70	DCK	5	3000	180.0	180.0	18.0
TPS3801T50DCKR	SC70	DCK	5	3000	202.0	201.0	28.0
TPS3802K33DCKR	SC70	DCK	5	3000	202.0	201.0	28.0
TPS3802L30DCKR	SC70	DCK	5	3000	202.0	201.0	28.0

DCK (R-PDSO-G5)

PLASTIC SMALL-OUTLINE PACKAGE



- NOTES:
- A. All linear dimensions are in millimeters.
 - B. This drawing is subject to change without notice.
 - C. Body dimensions do not include mold flash or protrusion. Mold flash and protrusion shall not exceed 0.15 per side.
 - D. Falls within JEDEC MO-203 variation AA.

DCK (R-PDSO-G5)

PLASTIC SMALL OUTLINE

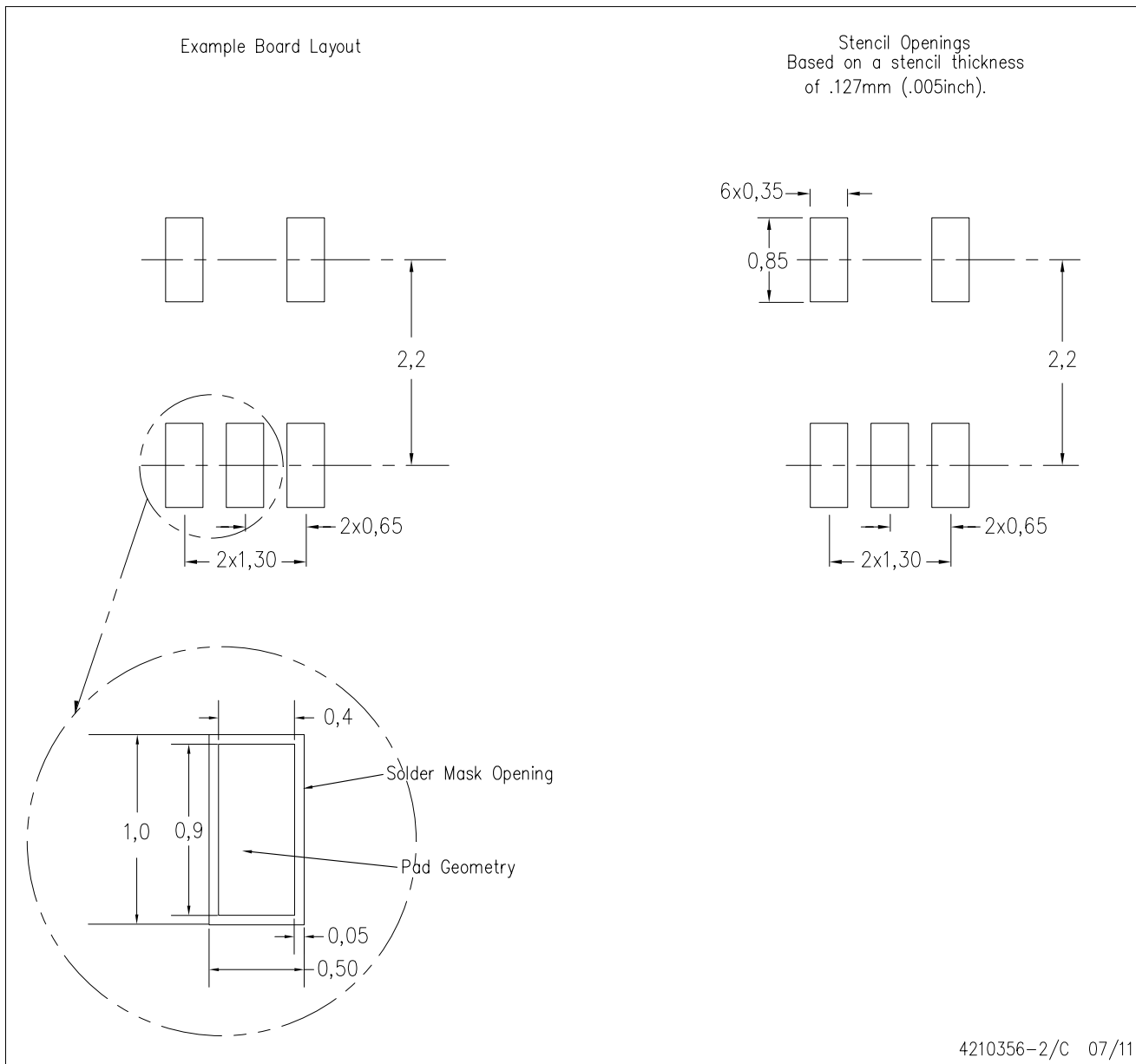

- NOTES:
- All linear dimensions are in millimeters.
 - This drawing is subject to change without notice.
 - Customers should place a note on the circuit board fabrication drawing not to alter the center solder mask defined pad.
 - Publication IPC-7351 is recommended for alternate designs.
 - Laser cutting apertures with trapezoidal walls and also rounding corners will offer better paste release. Customers should contact their board assembly site for stencil design recommendations. Example stencil design based on a 50% volumetric metal load solder paste. Refer to IPC-7525 for other stencil recommendations.

IMPORTANT NOTICE

Texas Instruments Incorporated and its subsidiaries (TI) reserve the right to make corrections, modifications, enhancements, improvements, and other changes to its products and services at any time and to discontinue any product or service without notice. Customers should obtain the latest relevant information before placing orders and should verify that such information is current and complete. All products are sold subject to TI's terms and conditions of sale supplied at the time of order acknowledgment.

TI warrants performance of its hardware products to the specifications applicable at the time of sale in accordance with TI's standard warranty. Testing and other quality control techniques are used to the extent TI deems necessary to support this warranty. Except where mandated by government requirements, testing of all parameters of each product is not necessarily performed.

TI assumes no liability for applications assistance or customer product design. Customers are responsible for their products and applications using TI components. To minimize the risks associated with customer products and applications, customers should provide adequate design and operating safeguards.

TI does not warrant or represent that any license, either express or implied, is granted under any TI patent right, copyright, mask work right, or other TI intellectual property right relating to any combination, machine, or process in which TI products or services are used. Information published by TI regarding third-party products or services does not constitute a license from TI to use such products or services or a warranty or endorsement thereof. Use of such information may require a license from a third party under the patents or other intellectual property of the third party, or a license from TI under the patents or other intellectual property of TI.

Reproduction of TI information in TI data books or data sheets is permissible only if reproduction is without alteration and is accompanied by all associated warranties, conditions, limitations, and notices. Reproduction of this information with alteration is an unfair and deceptive business practice. TI is not responsible or liable for such altered documentation. Information of third parties may be subject to additional restrictions.

Resale of TI products or services with statements different from or beyond the parameters stated by TI for that product or service voids all express and any implied warranties for the associated TI product or service and is an unfair and deceptive business practice. TI is not responsible or liable for any such statements.

TI products are not authorized for use in safety-critical applications (such as life support) where a failure of the TI product would reasonably be expected to cause severe personal injury or death, unless officers of the parties have executed an agreement specifically governing such use. Buyers represent that they have all necessary expertise in the safety and regulatory ramifications of their applications, and acknowledge and agree that they are solely responsible for all legal, regulatory and safety-related requirements concerning their products and any use of TI products in such safety-critical applications, notwithstanding any applications-related information or support that may be provided by TI. Further, Buyers must fully indemnify TI and its representatives against any damages arising out of the use of TI products in such safety-critical applications.

TI products are neither designed nor intended for use in military/aerospace applications or environments unless the TI products are specifically designated by TI as military-grade or "enhanced plastic." Only products designated by TI as military-grade meet military specifications. Buyers acknowledge and agree that any such use of TI products which TI has not designated as military-grade is solely at the Buyer's risk, and that they are solely responsible for compliance with all legal and regulatory requirements in connection with such use.

TI products are neither designed nor intended for use in automotive applications or environments unless the specific TI products are designated by TI as compliant with ISO/TS 16949 requirements. Buyers acknowledge and agree that, if they use any non-designated products in automotive applications, TI will not be responsible for any failure to meet such requirements.

Following are URLs where you can obtain information on other Texas Instruments products and application solutions:

Products

Audio	www.ti.com/audio
Amplifiers	amplifier.ti.com
Data Converters	dataconverter.ti.com
DLP® Products	www.dlp.com
DSP	dsp.ti.com
Clocks and Timers	www.ti.com/clocks
Interface	interface.ti.com
Logic	logic.ti.com
Power Mgmt	power.ti.com
Microcontrollers	microcontroller.ti.com
RFID	www.ti-rfid.com
OMAP Mobile Processors	www.ti.com/omap
Wireless Connectivity	www.ti.com/wirelessconnectivity

Applications

Automotive and Transportation	www.ti.com/automotive
Communications and Telecom	www.ti.com/communications
Computers and Peripherals	www.ti.com/computers
Consumer Electronics	www.ti.com/consumer-apps
Energy and Lighting	www.ti.com/energy
Industrial	www.ti.com/industrial
Medical	www.ti.com/medical
Security	www.ti.com/security
Space, Avionics and Defense	www.ti.com/space-avionics-defense
Video and Imaging	www.ti.com/video

TI E2E Community Home Page

e2e.ti.com

Mailing Address: Texas Instruments, Post Office Box 655303, Dallas, Texas 75265
Copyright © 2012, Texas Instruments Incorporated