

## TRIPLE PROCESSOR SUPERVISORS

### FEATURES

- Triple Supervisory Circuits for DSP and Processor-Based Systems
- Power-On Reset Generator With Fixed Delay Time of 200ms, No External Capacitor Needed
- Temperature-Compensated Voltage Reference
- Maximum Supply Current of 40µA
- Supply Voltage Range: 2V to 6V
- Defined  $\overline{\text{RESET}}$  Output From  $V_{\text{DD}} \geq 1.1\text{V}$
- MSOP-8 and SO-8 Packages
- Temperature Range :  $-40^{\circ}\text{C}$  to  $85^{\circ}\text{C}$

D OR DGN PACKAGE  
(TOP VIEW)

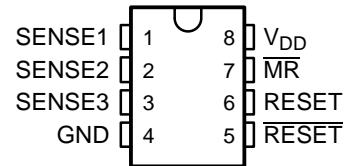

### Typical Applications

Figure 1 lists some of the typical applications for the TPS3307 family, and a schematic diagram for a processor-based system application. This application uses TI part numbers TPS3307-33 and MSP430C325.

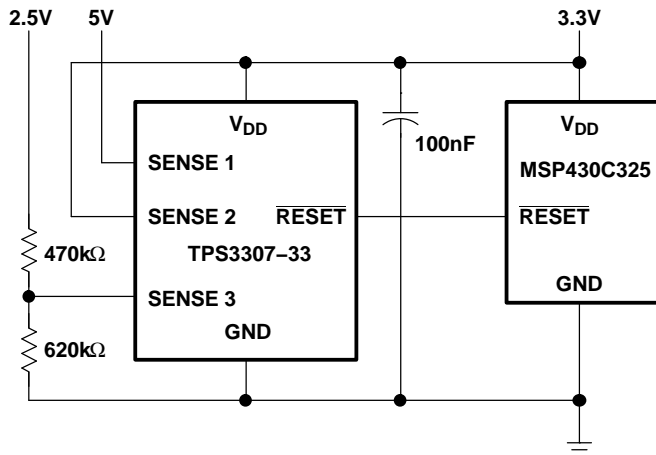

- Applications using DSPs, Microcontrollers or Microprocessors
- Industrial Equipment
- Programmable Controls
- Automotive Systems
- Portable/Battery Powered Equipment
- Intelligent Instruments
- Wireless Communication Systems
- Notebook/Desktop Computers

Figure 1. Applications Using the TPS3307 Family

### DESCRIPTION

The TPS3307 family is a series of micropower supply voltage supervisors designed for circuit initialization primarily in DSP and processor-based systems, which require more than one supply voltage.

The product spectrum of the TPS3307-xx is designed for monitoring three independent supply voltages: 3.3V/1.8V/adj, 3.3V/2.5V/adj or 3.3V/5V/adj. The adjustable SENSE input allows the monitoring of any supply voltage  $>1.25\text{V}$ .

The various supply voltage supervisors are designed to monitor the nominal supply voltage as shown in the following supply voltage monitoring table.

During power-on,  $\overline{\text{RESET}}$  is asserted when the supply voltage  $V_{\text{DD}}$  becomes higher than 1.1V. Thereafter, the supply voltage supervisor monitors the SENSE $n$  inputs and keeps  $\overline{\text{RESET}}$  active as long as SENSE $n$  remain below the threshold voltage  $V_{\text{IT}+}$ .



Please be aware that an important notice concerning availability, standard warranty, and use in critical applications of Texas Instruments semiconductor products and disclaimers thereto appears at the end of this data sheet.

PowerPAD is a trademark of Texas Instruments.

An internal timer delays the return of the  $\overline{\text{RESET}}$  output to the inactive state (high) to ensure proper system reset. The delay time,  $t_{d(\text{typ})} = 200\text{ms}$ , starts after all  $\text{SENSE}_n$  inputs have risen above the threshold voltage  $V_{IT+}$ . When the voltage at any SENSE input drops below the threshold voltage  $V_{IT-}$ , the RESET output becomes active (low) again.

The TPS3307-xx family of devices incorporates a manual reset input,  $\overline{\text{MR}}$ . A low level at  $\overline{\text{MR}}$  causes  $\overline{\text{RESET}}$  to become active. In addition to the active-low  $\overline{\text{RESET}}$  output, the TPS3307-xx family includes an active-high RESET output.

The devices are available in either 8-pin MSOP or standard 8-pin SO packages.

The TPS3307-xx devices are characterized for operation over a temperature range of  $-40^\circ\text{C}$  to  $85^\circ\text{C}$ .

**SUPPLY VOLTAGE MONITORING**

DEVICE	NOMINAL SUPERVISED VOLTAGE			THRESHOLD VOLTAGE (TYP)		
	SENSE1	SENSE2	SENSE3	SENSE1	SENSE2	SENSE3
TPS3307-18	3.3V	1.8V	User defined	2.93V	1.68V	1.25V <sup>(1)</sup>
TPS3307-25	3.3V	2.5V	User defined	2.93V	2.25V	1.25V <sup>(1)</sup>
TPS3307-33	5V	3.3V	User defined	4.55V	2.93V	1.25V <sup>(1)</sup>

(1) The actual sense voltage has to be adjusted by an external resistor divider according to the application requirements.

**AVAILABLE OPTIONS**

$T_A$	PACKAGED DEVICES		MARKING DGN PACKAGE	CHIP FORM (Y)
	SMALL OUTLINE (D)	PowerPAD™ μ-SMALL OUTLINE (DGN)		
$-40^\circ\text{C}$ to $85^\circ\text{C}$	TPS3307-18D	TPS3307-18DGN	TIAAP	TPS3307-18Y
	TPS3307-25D	TPS3307-25DGN	TIAAQ	TPS3307-25Y
	TPS3307-33D	TPS3307-33DGN	TIAAR	TPS3307-33Y

**FUNCTION/TRUTH TABLES**

$\overline{\text{MR}}$	$\text{SENSE1} > V_{IT1}$	$\text{SENSE2} > V_{IT2}$	$\text{SENSE3} > V_{IT3}$	RESET	RESET
L	X <sup>(1)</sup>	X <sup>(1)</sup>	X	L	H
H	0	0	0	L	H
H	0	0	1	L	H
H	0	1	0	L	H
H	0	1	1	L	H
H	1	0	0	L	H
H	1	0	1	L	H
H	1	1	0	L	H
H	1	1	1	H	L

(1) X = Don't care

**Functional Block Diagram**

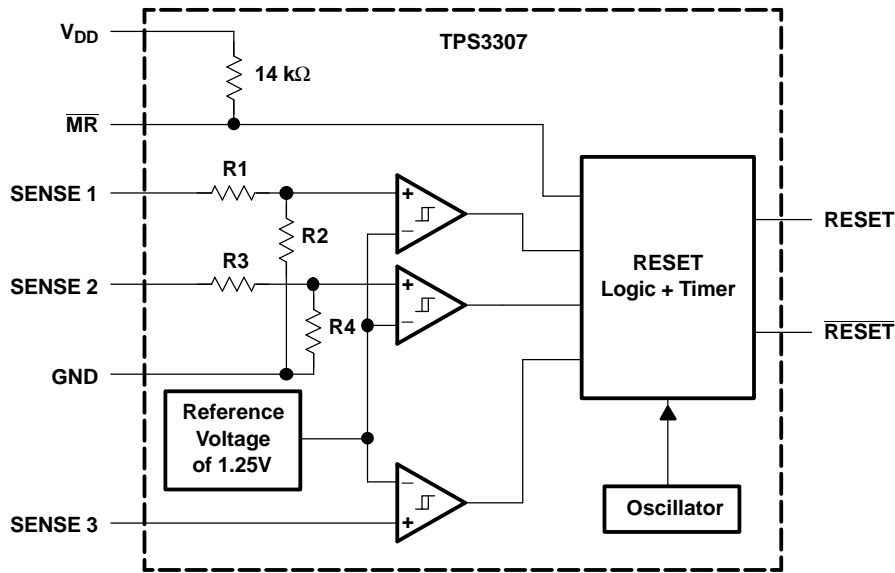

**Timing Diagram**

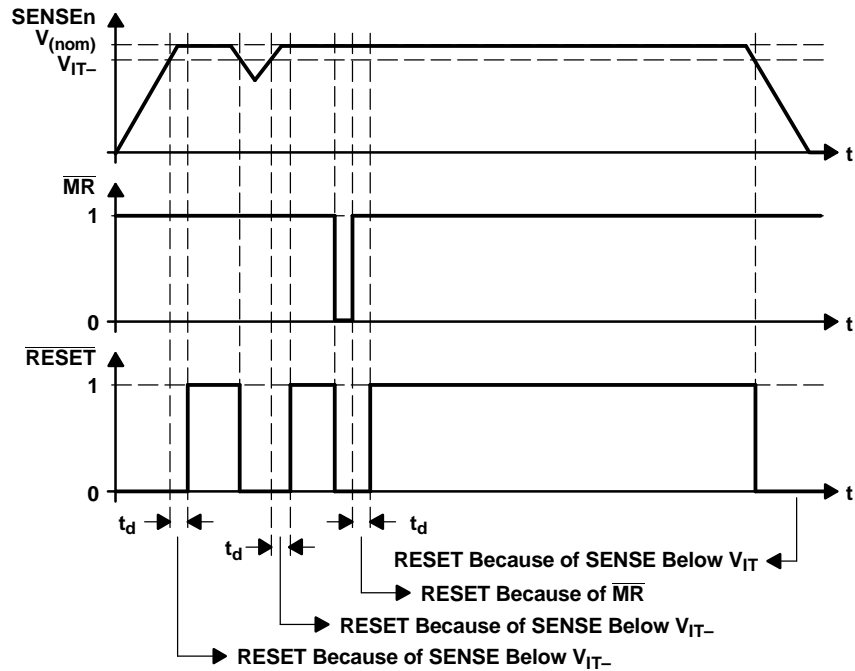

**TPS3307Y Chip Information**

These chips, when properly assembled, display characteristics similar to those of the TPS3307. Thermal compression or ultrasonic bonding may take place on the doped aluminium bonding pads. The chips may be mounted with conductive epoxy or a gold-silicon preform.

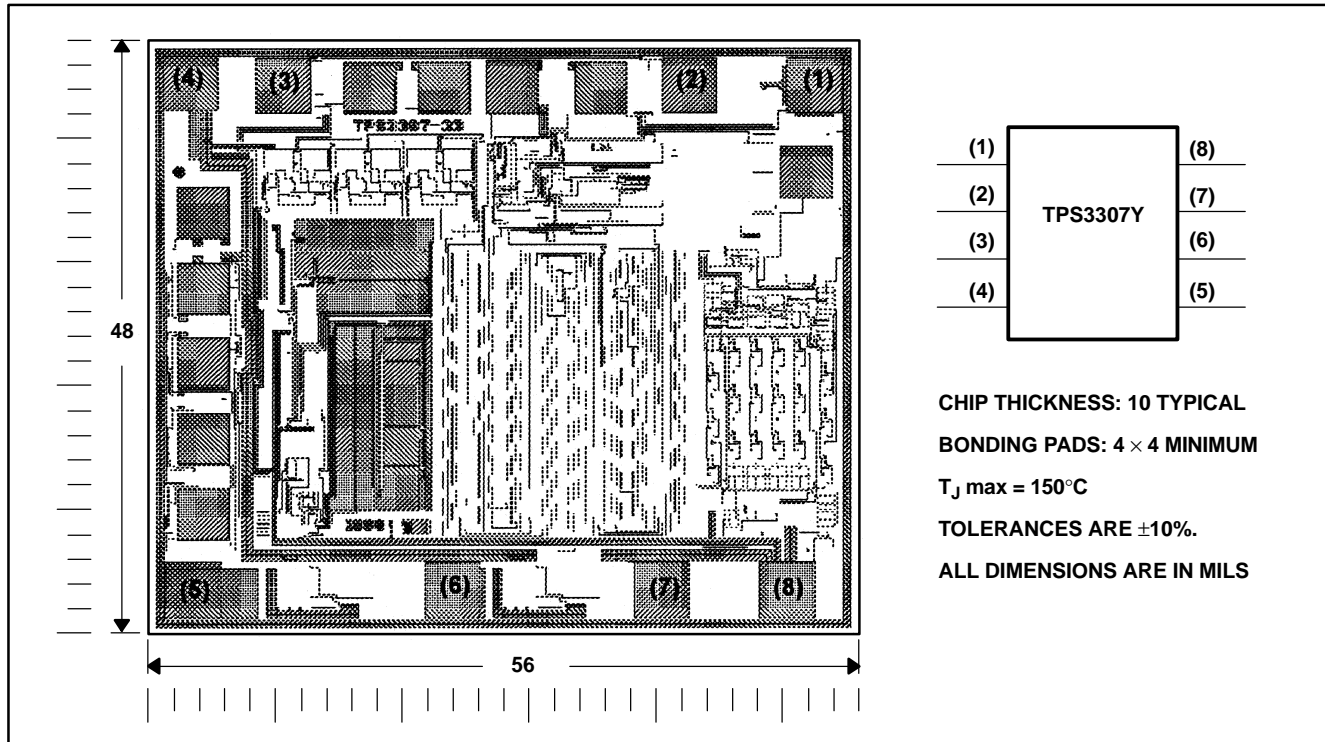

### Terminal Functions

TERMINAL NAME	NO.	I/O	DESCRIPTION
GND	4		Ground
MR	7	I	Manual reset
RESET	5	O	Active-low reset output
RESET	6	O	Active-high reset output
SENSE1	1	I	Sense voltage input 1
SENSE2	2	I	Sense voltage input 2
SENSE3	3	I	Sense voltage input 3
V <sub>DD</sub>	8		Supply voltage

## Absolute Maximum Ratings<sup>(1)</sup>

Over operating free-air temperature range (unless otherwise noted).

	UNIT
Supply voltage, $V_{DD}$ <sup>(2)</sup>	7V
All other pins <sup>(2)</sup>	-0.3V to 7V
Maximum low output current, $I_{OL}$	5mA
Maximum high output current, $I_{OH}$	-5mA
Input clamp current, $I_{IK}$ ( $V_I < 0$ or $V_I > V_{DD}$ )	±20mA
Output clamp current, $I_{OK}$ ( $V_O < 0$ or $V_O > V_{DD}$ )	±20mA
Continuous total power dissipation	See Dissipation Rating Table
Operating free-air temperature range, $T_A$	-40°C to 85°C
Storage temperature range, $T_{stg}$	-65°C to 150°C
Soldering temperature	260°C

- (1) Stresses beyond those listed under absolute maximum ratings may cause permanent damage to the device. These are stress ratings only, and functional operation of the device at these or any other conditions beyond those indicated under recommended operating conditions is not implied. Exposure to absolute-maximum-rated conditions for extended periods may affect device reliability.
- (2) All voltage values are with respect to GND. For reliable operation the device must not be operated at 7V for more than  $t = 1000h$  continuously.

## Dissipation Rating Table

PACKAGE	$T_A \leq 25^\circ\text{C}$ POWER RATING	DERATING FACTOR ABOVE $T_A = 25^\circ\text{C}$	$T_A = 70^\circ\text{C}$ POWER RATING	$T_A = 85^\circ\text{C}$ POWER RATING
DGN	2.14W	17.1mW/°C	1.37W	1.11W
D	725mW	5.8mW/°C	464mW	377mW

## Recommended Operating Conditions

At specified temperature range.

	MIN	MAX	UNIT
Supply voltage, $V_{DD}$	2	6	V
Input voltage at $\overline{MR}$ and SENSE3, $V_I$	0	$V_{DD} + 0.3$	V
Input voltage at SENSE1 and SENSE2, $V_I$	0	$(V_{DD} + 0.3)V_{IT}/1.25V$	V
High-level input voltage at $\overline{MR}$ , $V_{IH}$	$0.7 \times V_{DD}$		V
Low-level input voltage at $\overline{MR}$ , $V_{IL}$		$0.3 \times V_{DD}$	V
Input transition rise and fall rate at $\overline{MR}$ , $\Delta t/\Delta V$		50	ns/V
Operating free-air temperature range, $T_A$	-40	85	°C

### Electrical Characteristics

Over recommended operating free-air temperature range (unless otherwise noted)

PARAMETER		TEST CONDITIONS	MIN	TYP	MAX	UNIT		
V <sub>OH</sub>	High-level output voltage	V <sub>DD</sub> = 2V to 6V, I <sub>OH</sub> = -20 μA	V <sub>DD</sub> - 0.2V			V		
		V <sub>DD</sub> = 3.3V, I <sub>OH</sub> = -2mA	V <sub>DD</sub> - 0.4V					
		V <sub>DD</sub> = 6V, I <sub>OH</sub> = -3mA	V <sub>DD</sub> - 0.4V					
V <sub>OL</sub>	Low-level output voltage	V <sub>DD</sub> = 2V to 6V, I <sub>OL</sub> = 20μA	0.2			V		
		V <sub>DD</sub> = 3.3V, I <sub>OL</sub> = 2mA	0.4					
		V <sub>DD</sub> = 6V, I <sub>OL</sub> = 3mA	0.4					
Power-up reset voltage <sup>(1)</sup>		V <sub>DD</sub> ≥ 1.1V, I <sub>OL</sub> = 20μA	0.4			V		
V <sub>IT-</sub>	Negative-going input threshold voltage <sup>(2)</sup>	V <sub>DD</sub> = 2V to 6V, T <sub>A</sub> = 0°C to 85°C	VSENSE3	1.22	1.25	1.28	V	
			VSENSE1, VSENSE2	1.64	1.68	1.72		
				2.20	2.25	2.30		
				2.86	2.93	3		
	Negative-going input threshold voltage <sup>(2)</sup>	V <sub>DD</sub> = 2V to 6V, T <sub>A</sub> = -40°C to 85°C	VSENSE3	1.22	1.25	1.29	V	
				VSENSE1, VSENSE2	1.64	1.68		1.73
					2.20	2.25		2.32
					2.86	2.93		3.02
V <sub>hys</sub>	Hysteresis at VSENSEn input	V <sub>IT-</sub> = 1.25V	10			mV		
		V <sub>IT-</sub> = 1.68V	15					
		V <sub>IT-</sub> = 2.25V	20					
		V <sub>IT-</sub> = 2.93V	30					
		V <sub>IT-</sub> = 4.55V	40					
I <sub>H</sub>	High-level input current	MR	MR = 0.7 × V <sub>DD</sub> , V <sub>DD</sub> = 6 V			μA		
		SENSE1	VSENSE1 = V <sub>DD</sub> = 6V					
		SENSE2	VSENSE2 = V <sub>DD</sub> = 6V					
		SENSE3	VSENSE3 = V <sub>DD</sub>					
I <sub>L</sub>	Low-level input current	MR	MR = 0V, V <sub>DD</sub> = 6V			μA		
		SENSEn	VSENSE1,2,3 = 0V			nA		
I <sub>DD</sub>	Supply current		40			μA		
C <sub>i</sub>	Input capacitance	V <sub>I</sub> = 0V to V <sub>DD</sub>	10			pF		

(1) The lowest supply voltage at which **RESET** becomes active. t<sub>r</sub>, V<sub>DD</sub> ≥ 15μs/V

(2) To ensure best stability of the threshold voltage, a bypass capacitor (ceramic 0.1μF) should be placed close to the supply terminals.

## Timing Requirements

At  $V_{DD} = 2V$  to  $6V$ ,  $R_L = 1M\Omega$ ,  $C_L = 50pF$ ,  $T_A = 25^\circ C$ .

PARAMETER		TEST CONDITIONS	MIN	TYP	MAX	UNIT
$t_w$	Pulse width					
	SENSEn	$V_{SENSEnL} = V_{IT-} - 0.2V$ , $V_{SENSEnH} = V_{IT+} + 0.2V$	6			$\mu s$
	$\overline{MR}$	$V_{IH} = 0.7 \times V_{DD}$ , $V_{IL} = 0.3 \times V_{DD}$	100			ns

## Switching Characteristics

At  $V_{DD} = 2V$  to  $6V$ ,  $R_L = 1M\Omega$ ,  $C_L = 50pF$ ,  $T_A = 25^\circ C$ .

PARAMETER		TEST CONDITIONS	MIN	TYP	MAX	UNIT
$t_d$	Delay time	$V_{I(SENSEn)} \geq V_{IT+} + 0.2V$ , $\overline{MR} \geq 0.7 \times V_{DD}$ . See Timing Diagram.	140	200	280	ms
$t_{PHL}$	Propagation (delay) time, high-to-low level output	$\overline{MR}$ to $\overline{RESETMR}$ to RESET		200	500	ns
$t_{PLH}$	Propagation (delay) time, low-to-high level output	$\overline{MR}$ to $\overline{RESETMR}$ to RESET				
$t_{PHL}$	Propagation (delay) time, high-to-low level output	SENSEn to $\overline{RESET}$ SENSEn to RESET		1	5	$\mu s$
$t_{PLH}$	Propagation (delay) time, low-to-high level output	SENSEn to $\overline{RESET}$ SENSEn to RESET				

Typical Characteristics

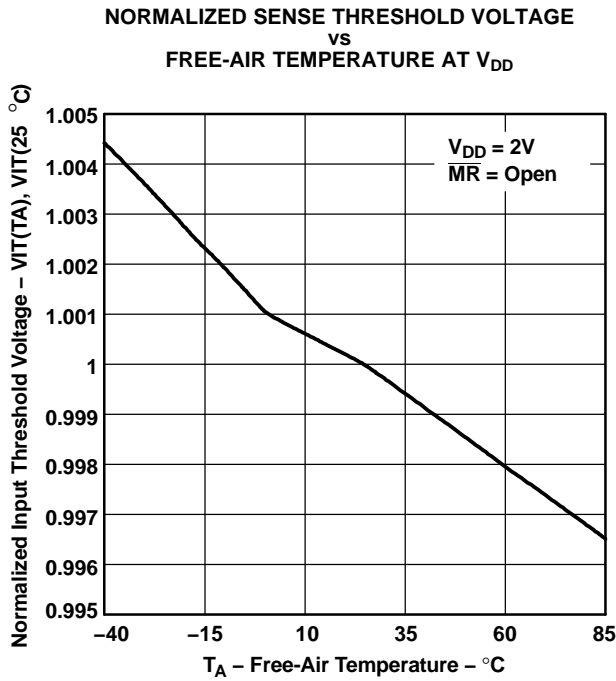

Figure 2.

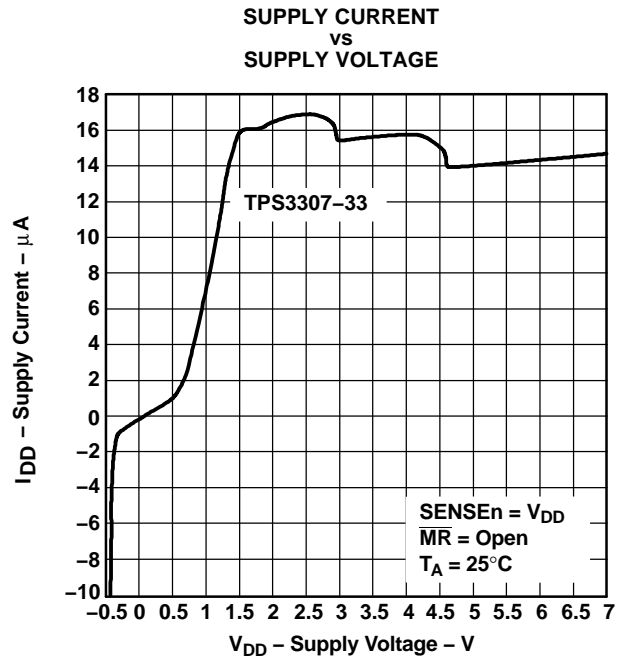

Figure 3.

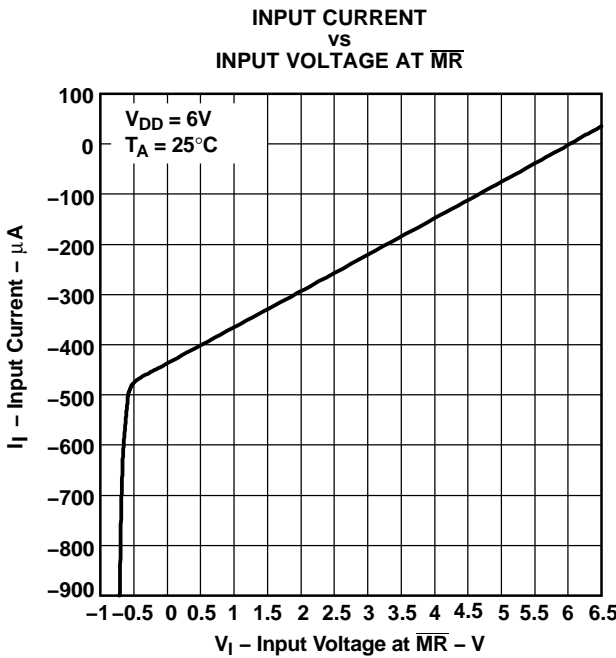

Figure 4.

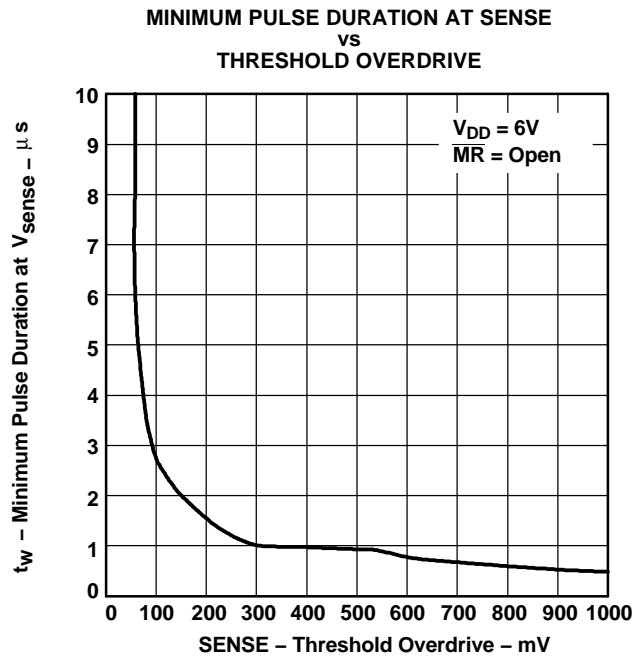
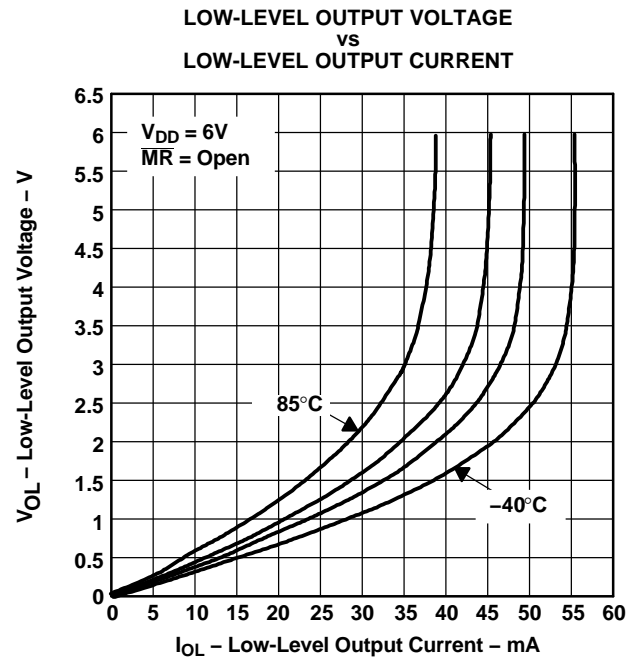
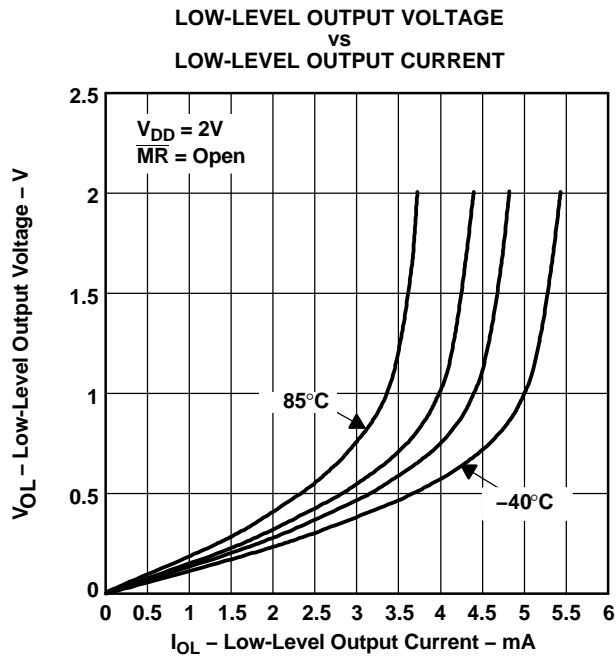
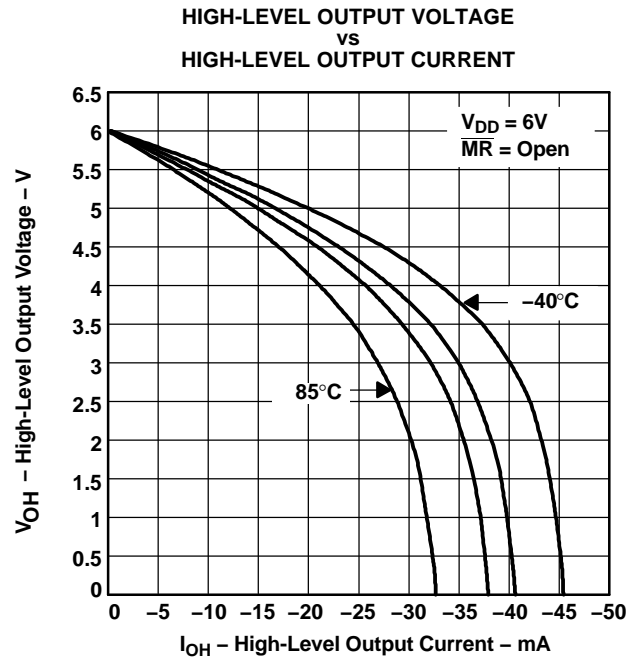
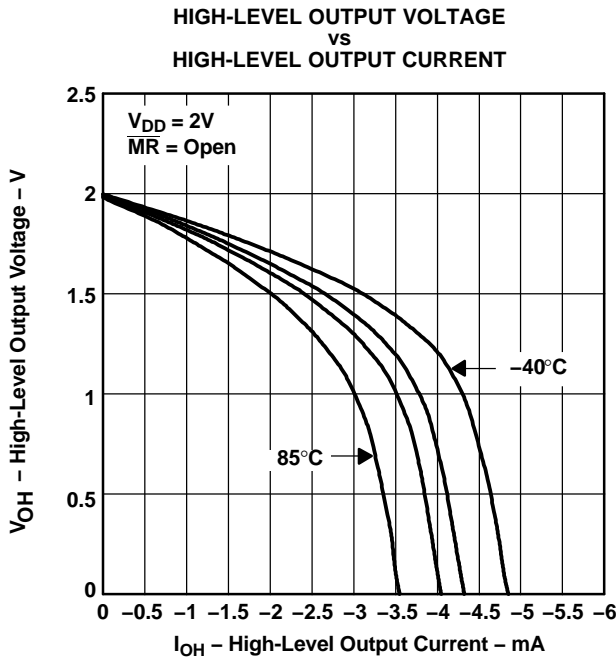

Figure 5.

Typical Characteristics (continued)



THERMAL INFORMATION

This PowerPAD™ package incorporates an exposed thermal pad that is designed to be attached directly to an external heatsink. When the thermal pad is soldered directly to the printed circuit board (PCB), the PCB can be used as a heatsink. In addition, through the use of thermal vias, the thermal pad can be attached directly to a ground plane or special heatsink structure designed into the PCB. This design optimizes the heat transfer from the integrated circuit (IC).

For additional information on the PowerPAD package and how to take advantage of its heat dissipating abilities, refer to Technical Brief, PowerPAD Thermally Enhanced Package, Texas Instruments Literature No. SLMA002 and Application Brief, PowerPAD Made Easy, Texas Instruments Literature No. SLMA004. Both documents are available at [www.ti.com](http://www.ti.com).

The exposed thermal pad dimensions for this package are shown in the following illustration.

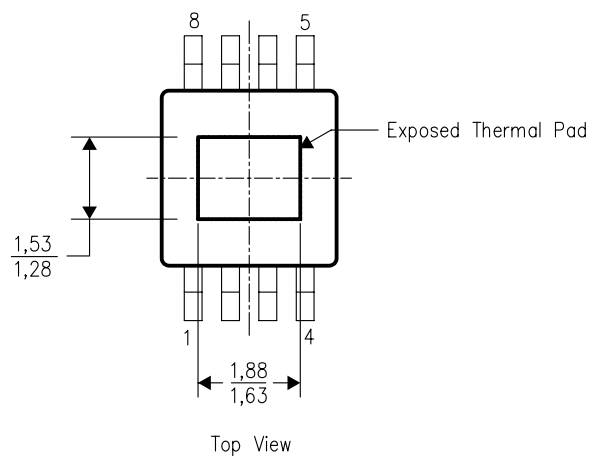

NOTE: All linear dimensions are in millimeters

Exposed Thermal Pad Dimensions

**PACKAGING INFORMATION**

Orderable Device	Status <sup>(1)</sup>	Package Type	Package Drawing	Pins	Package Qty	Eco Plan <sup>(2)</sup>	Lead/Ball Finish	MSL Peak Temp <sup>(3)</sup>
TPS3307-18D	ACTIVE	SOIC	D	8	75	Green (RoHS & no Sb/Br)	CU NIPDAU	Level-1-260C-UNLIM
TPS3307-18DGN	ACTIVE	MSOP-Power PAD	DGN	8	80	Green (RoHS & no Sb/Br)	CU NIPDAU	Level-1-260C-UNLIM
TPS3307-18DGNG4	ACTIVE	MSOP-Power PAD	DGN	8	80	Green (RoHS & no Sb/Br)	CU NIPDAU	Level-1-260C-UNLIM
TPS3307-18DGNR	ACTIVE	MSOP-Power PAD	DGN	8	2500	Green (RoHS & no Sb/Br)	CU NIPDAU	Level-1-260C-UNLIM
TPS3307-18DGNRG4	ACTIVE	MSOP-Power PAD	DGN	8	2500	Green (RoHS & no Sb/Br)	CU NIPDAU	Level-1-260C-UNLIM
TPS3307-18DR	ACTIVE	SOIC	D	8	2500	Green (RoHS & no Sb/Br)	CU NIPDAU	Level-1-260C-UNLIM
TPS3307-18DRG4	ACTIVE	SOIC	D	8	2500	Green (RoHS & no Sb/Br)	CU NIPDAU	Level-1-260C-UNLIM
TPS3307-25D	ACTIVE	SOIC	D	8	75	Green (RoHS & no Sb/Br)	CU NIPDAU	Level-1-260C-UNLIM
TPS3307-25DG4	ACTIVE	SOIC	D	8	75	Green (RoHS & no Sb/Br)	CU NIPDAU	Level-1-260C-UNLIM
TPS3307-25DGN	ACTIVE	MSOP-Power PAD	DGN	8	80	Green (RoHS & no Sb/Br)	CU NIPDAU	Level-1-260C-UNLIM
TPS3307-25DGNG4	ACTIVE	MSOP-Power PAD	DGN	8	80	Green (RoHS & no Sb/Br)	CU NIPDAU	Level-1-260C-UNLIM
TPS3307-25DGNR	ACTIVE	MSOP-Power PAD	DGN	8	2500	Green (RoHS & no Sb/Br)	CU NIPDAU	Level-1-260C-UNLIM
TPS3307-25DGNRG4	ACTIVE	MSOP-Power PAD	DGN	8	2500	Green (RoHS & no Sb/Br)	CU NIPDAU	Level-1-260C-UNLIM
TPS3307-25DR	ACTIVE	SOIC	D	8	2500	Green (RoHS & no Sb/Br)	CU NIPDAU	Level-1-260C-UNLIM
TPS3307-25DRG4	ACTIVE	SOIC	D	8	2500	Green (RoHS & no Sb/Br)	CU NIPDAU	Level-1-260C-UNLIM
TPS3307-33D	ACTIVE	SOIC	D	8	75	Green (RoHS & no Sb/Br)	CU NIPDAU	Level-1-260C-UNLIM
TPS3307-33DG4	ACTIVE	SOIC	D	8	75	Green (RoHS & no Sb/Br)	CU NIPDAU	Level-1-260C-UNLIM
TPS3307-33DGN	ACTIVE	MSOP-Power PAD	DGN	8	80	Green (RoHS & no Sb/Br)	CU NIPDAU	Level-1-260C-UNLIM
TPS3307-33DGNR	ACTIVE	MSOP-Power PAD	DGN	8	2500	Green (RoHS & no Sb/Br)	CU NIPDAU	Level-1-260C-UNLIM
TPS3307-33DGNRG4	ACTIVE	MSOP-Power PAD	DGN	8	2500	Green (RoHS & no Sb/Br)	CU NIPDAU	Level-1-260C-UNLIM

Orderable Device	Status <sup>(1)</sup>	Package Type	Package Drawing	Pins	Package Qty	Eco Plan <sup>(2)</sup>	Lead/Ball Finish	MSL Peak Temp <sup>(3)</sup>
TPS3307-33DR	ACTIVE	SOIC	D	8	2500	Green (RoHS & no Sb/Br)	CU NIPDAU	Level-1-260C-UNLIM
TPS3307-33DRG4	ACTIVE	SOIC	D	8	2500	Green (RoHS & no Sb/Br)	CU NIPDAU	Level-1-260C-UNLIM

<sup>(1)</sup> The marketing status values are defined as follows:

**ACTIVE:** Product device recommended for new designs.

**LIFEBUY:** TI has announced that the device will be discontinued, and a lifetime-buy period is in effect.

**NRND:** Not recommended for new designs. Device is in production to support existing customers, but TI does not recommend using this part in a new design.

**PREVIEW:** Device has been announced but is not in production. Samples may or may not be available.

**OBSOLETE:** TI has discontinued the production of the device.

<sup>(2)</sup> Eco Plan - The planned eco-friendly classification: Pb-Free (RoHS) or Green (RoHS & no Sb/Br) - please check <http://www.ti.com/productcontent> for the latest availability information and additional product content details.

**TBD:** The Pb-Free/Green conversion plan has not been defined.

**Pb-Free (RoHS):** TI's terms "Lead-Free" or "Pb-Free" mean semiconductor products that are compatible with the current RoHS requirements for all 6 substances, including the requirement that lead not exceed 0.1% by weight in homogeneous materials. Where designed to be soldered at high temperatures, TI Pb-Free products are suitable for use in specified lead-free processes.

**Green (RoHS & no Sb/Br):** TI defines "Green" to mean Pb-Free (RoHS compatible), and free of Bromine (Br) and Antimony (Sb) based flame retardants (Br or Sb do not exceed 0.1% by weight in homogeneous material)

<sup>(3)</sup> MSL, Peak Temp. -- The Moisture Sensitivity Level rating according to the JEDEC industry standard classifications, and peak solder temperature.

**Important Information and Disclaimer:**The information provided on this page represents TI's knowledge and belief as of the date that it is provided. TI bases its knowledge and belief on information provided by third parties, and makes no representation or warranty as to the accuracy of such information. Efforts are underway to better integrate information from third parties. TI has taken and continues to take reasonable steps to provide representative and accurate information but may not have conducted destructive testing or chemical analysis on incoming materials and chemicals. TI and TI suppliers consider certain information to be proprietary, and thus CAS numbers and other limited information may not be available for release.

In no event shall TI's liability arising out of such information exceed the total purchase price of the TI part(s) at issue in this document sold by TI to Customer on an annual basis.

DGN (S-PDSO-G8)

PowerPAD™ PLASTIC SMALL-OUTLINE PACKAGE

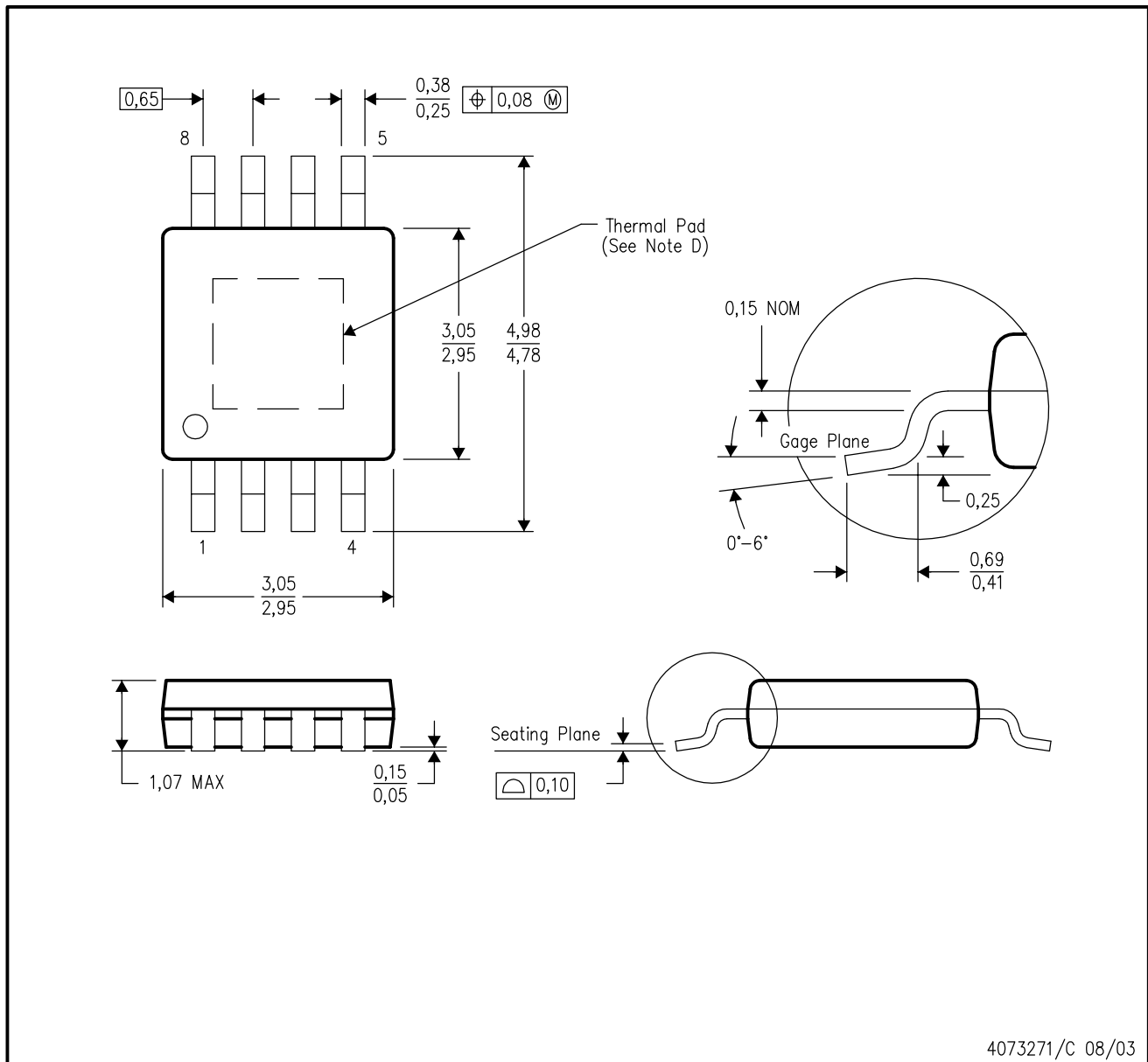

- NOTES:
- All linear dimensions are in millimeters.
  - This drawing is subject to change without notice.
  - Body dimensions do not include mold flash or protrusion.
  - This package is designed to be soldered to a thermal pad on the board. Refer to Technical Brief, PowerPad Thermally Enhanced Package, Texas Instruments Literature No. SLMA002 for information regarding recommended board layout. This document is available at [www.ti.com](http://www.ti.com) <<http://www.ti.com>>.
  - Falls within JEDEC MO-187

PowerPAD is a trademark of Texas Instruments.



## IMPORTANT NOTICE

Texas Instruments Incorporated and its subsidiaries (TI) reserve the right to make corrections, modifications, enhancements, improvements, and other changes to its products and services at any time and to discontinue any product or service without notice. Customers should obtain the latest relevant information before placing orders and should verify that such information is current and complete. All products are sold subject to TI's terms and conditions of sale supplied at the time of order acknowledgment.

TI warrants performance of its hardware products to the specifications applicable at the time of sale in accordance with TI's standard warranty. Testing and other quality control techniques are used to the extent TI deems necessary to support this warranty. Except where mandated by government requirements, testing of all parameters of each product is not necessarily performed.

TI assumes no liability for applications assistance or customer product design. Customers are responsible for their products and applications using TI components. To minimize the risks associated with customer products and applications, customers should provide adequate design and operating safeguards.

TI does not warrant or represent that any license, either express or implied, is granted under any TI patent right, copyright, mask work right, or other TI intellectual property right relating to any combination, machine, or process in which TI products or services are used. Information published by TI regarding third-party products or services does not constitute a license from TI to use such products or services or a warranty or endorsement thereof. Use of such information may require a license from a third party under the patents or other intellectual property of the third party, or a license from TI under the patents or other intellectual property of TI.

Reproduction of information in TI data books or data sheets is permissible only if reproduction is without alteration and is accompanied by all associated warranties, conditions, limitations, and notices. Reproduction of this information with alteration is an unfair and deceptive business practice. TI is not responsible or liable for such altered documentation.

Resale of TI products or services with statements different from or beyond the parameters stated by TI for that product or service voids all express and any implied warranties for the associated TI product or service and is an unfair and deceptive business practice. TI is not responsible or liable for any such statements.

Following are URLs where you can obtain information on other Texas Instruments products and application solutions:

<b>Products</b>		<b>Applications</b>	
Amplifiers	<a href="http://amplifier.ti.com">amplifier.ti.com</a>	Audio	<a href="http://www.ti.com/audio">www.ti.com/audio</a>
Data Converters	<a href="http://dataconverter.ti.com">dataconverter.ti.com</a>	Automotive	<a href="http://www.ti.com/automotive">www.ti.com/automotive</a>
DSP	<a href="http://dsp.ti.com">dsp.ti.com</a>	Broadband	<a href="http://www.ti.com/broadband">www.ti.com/broadband</a>
Interface	<a href="http://interface.ti.com">interface.ti.com</a>	Digital Control	<a href="http://www.ti.com/digitalcontrol">www.ti.com/digitalcontrol</a>
Logic	<a href="http://logic.ti.com">logic.ti.com</a>	Military	<a href="http://www.ti.com/military">www.ti.com/military</a>
Power Mgmt	<a href="http://power.ti.com">power.ti.com</a>	Optical Networking	<a href="http://www.ti.com/opticalnetwork">www.ti.com/opticalnetwork</a>
Microcontrollers	<a href="http://microcontroller.ti.com">microcontroller.ti.com</a>	Security	<a href="http://www.ti.com/security">www.ti.com/security</a>
		Telephony	<a href="http://www.ti.com/telephony">www.ti.com/telephony</a>
		Video & Imaging	<a href="http://www.ti.com/video">www.ti.com/video</a>
		Wireless	<a href="http://www.ti.com/wireless">www.ti.com/wireless</a>

Mailing Address: Texas Instruments  
Post Office Box 655303 Dallas, Texas 75265