

## UltraLow Supply-Current/Supply-Voltage Supervisory Circuits

### FEATURES

- Precision Supply Voltage Supervision Range: 0.9 V, 1.2 V, 1.5 V, 1.6 V, 2 V, and 3.3 V
- High Trip-Point Accuracy: 0.75%
- Supply Current of 1.2  $\mu$ A (typical)
- **RESET** Defined With Input Voltages as Low as 0.4 V
- Power-On Reset Generator With a Delay Time of 130 ms
- Push/Pull or Open-Drain **RESET** Outputs
- SOT23-6 Package
- Package Temperature Range:  $-40^{\circ}\text{C}$  to  $+85^{\circ}\text{C}$

### APPLICATIONS

- Applications Using Low-Power DSPs, Microcontrollers, or Microprocessors
- Portable- and Battery-Powered Equipment
- Intelligent Instruments
- Wireless Communication Systems
- Industrial Equipment
- Notebook/Desktop Computers

### DESCRIPTION

The TPS310x and TPS311x families of supervisory circuits provide circuit initialization and timing supervision, primarily for DSP and processor-based systems.

During power-on, **RESET** is asserted when the supply voltage ( $V_{DD}$ ) becomes higher than 0.4 V. Thereafter, the supervisory circuit monitors  $V_{DD}$  and keeps the **RESET** output active as long as  $V_{DD}$  remains below the threshold voltage ( $V_{IT}$ ). An internal timer delays the return of the output to the inactive state to ensure proper system reset. The delay time starts after  $V_{DD}$  has risen above  $V_{IT}$ . When  $V_{DD}$  drops below  $V_{IT}$ , the output becomes active again.

All the devices of this family have a fixed-sense threshold voltage ( $V_{IT}$ ) set by an internal voltage divider.

The TPS3103 and TPS3106 have an active-low, open-drain **RESET** output. The TPS3110 has an active-low push/pull **RESET**.

The product spectrum is designed for supply voltages of 0.9 V up to 3.3 V. The circuits are available in SOT23-6 packages. The TPS31xx family is characterized for operation over a temperature range of  $-40^{\circ}\text{C}$  to  $+85^{\circ}\text{C}$ .

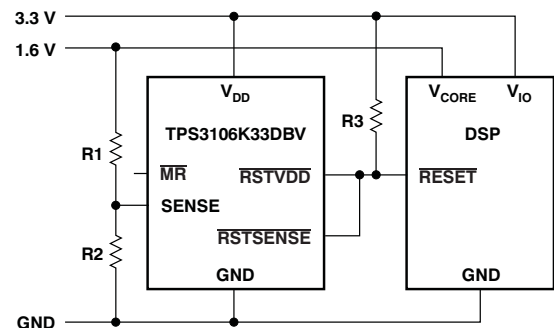
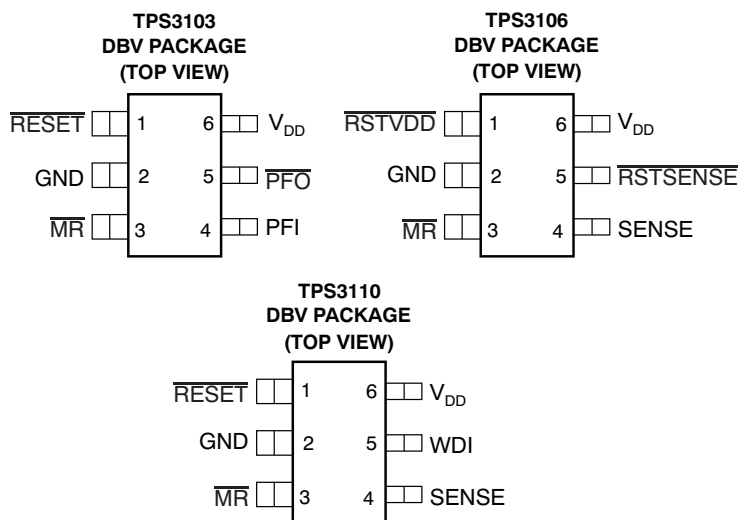

**Typical Application Circuit**



Please be aware that an important notice concerning availability, standard warranty, and use in critical applications of Texas Instruments semiconductor products and disclaimers thereto appears at the end of this data sheet.

All trademarks are the property of their respective owners.



This integrated circuit can be damaged by ESD. Texas Instruments recommends that all integrated circuits be handled with appropriate precautions. Failure to observe proper handling and installation procedures can cause damage.

ESD damage can range from subtle performance degradation to complete device failure. Precision integrated circuits may be more susceptible to damage because very small parametric changes could cause the device not to meet its published specifications.

### ORDERING INFORMATION<sup>(1)</sup>

PRODUCT	NOMINAL SUPPLY VOLTAGE	THRESHOLD VOLTAGE, $V_{IT}$ <sup>(2)</sup>
TPS3103E12DBVR	1.2 V	1.142 V
TPS3103E15DBVR	1.5 V	1.434 V
TPS3103H20DBVR	2.0 V	1.84 V
TPS3103K33DBVR	3.3 V	2.941 V
TPS3106E09DBVR	0.9 V	0.86 V
TPS3106E16DBVR	1.6 V	1.521 V
TPS3106K33DBVR	3.3 V	2.941 V
TPS3110E09DBVR	0.9 V	0.86 V
TPS3110E12DBVR	1.2 V	1.142 V
TPS3110E15DBVR	1.5 V	1.434 V
TPS3110K33DBVR	3.3 V	2.941 V

- (1) For the most current package and ordering information see the Package Option Addendum at the end of this document, or see the TI web site at [www.ti.com](http://www.ti.com).
- (2) Custom threshold voltages are available. Minimum order quantities apply. Contact factory for details and availability.

### AVAILABLE OPTIONS

DEVICE	RESET OUTPUT	RSTSENSE, RSTVDD OUTPUT	SENSE INPUT	WDI INPUT	PF $\bar{O}$ OUTPUT
TPS3103	Open-drain				Open-drain
TPS3106		Open-drain	$\bar{u}$		
TPS3110	Push-pull		$\bar{u}$	$\bar{u}$	

### ABSOLUTE MAXIMUM RATINGS<sup>(1)</sup>

Over operating free-air temperature range, unless otherwise noted.

	VALUE	UNIT
Supply voltage, $V_{DD}$ <sup>(2)</sup>	–0.3 to +3.6	V
$\bar{MR}$ Pin, $V_{\bar{MR}}$	–0.3 to $V_{DD} + 0.3$	V
All other pins <sup>(2)</sup>	–0.3 to +3.6	V
Maximum low output current, $I_{OL}$	5	mA
Maximum high output current, $I_{OH}$	–5	mA
Input clamp current, $I_{IK}$ ( $V_I < 0$ or $V_I > V_{DD}$ )	$\pm 10$	mA
Output clamp current, $I_{OK}$ ( $V_O < 0$ or $V_O > V_{DD}$ )	$\pm 10$	mA
Continuous total power dissipation	See <a href="#">Dissipation Rating Table</a>	
Operating temperature range, $T_A$	–40 to +85	°C
Storage temperature range, $T_{STG}$	–65 to +150	°C
Soldering temperature	+260	°C

- (1) Stresses beyond those listed under [absolute maximum ratings](#) may cause permanent damage to the device. These are stress ratings only, and functional operation of the device at these or any other conditions beyond those indicated under [recommended operating conditions](#) is not implied. Exposure to absolute-maximum-rated conditions for extended periods may affect device reliability.
- (2) All voltage values are with respect to GND. For reliable operation, the device must not be operated at 3.6 V for more than  $t = 1000h$  continuously.

## DISSIPATION RATINGS

PACKAGE	$T_A \leq 25^\circ\text{C}$ POWER RATING	DERATING FACTOR ABOVE $T_A = +25^\circ\text{C}$	$T_A = +70^\circ\text{C}$ POWER RATING	$T_A = +85^\circ\text{C}$ POWER RATING
DBV	437 mW	3.5 mW/°C	280 mW	227 mW

## RECOMMENDED OPERATING CONDITIONS

Over operating free-air temperature range, unless otherwise noted.

	MIN	MAX	UNIT
Supply voltage, $V_{DD}^{(1)}$	0.4	3.3	V
Input voltage, $V_I$	0	$V_{DD} + 0.3$	V
High-level input voltage, $V_{IH}$ at $\overline{MR}$ , WDI	$0.7 \times V_{DD}$		V
Low-level input voltage, $V_{IL}$ at $\overline{MR}$ , WDI		$0.3 \times V_{DD}$	V
Input transition rise and fall rate at $\Delta t/\Delta V$ at $\overline{MR}$ , WDI		100	ns/V
Operating temperature range, $T_A$	-40	+85	°C

(1) For proper operation of SENSE, PFI, and WDI functions:  $V_{DD} \geq 0.8$  V.

## ELECTRICAL CHARACTERISTICS

over operating free-air temperature range (unless otherwise noted)

PARAMETER		TEST CONDITIONS	MIN	TYP	MAX	UNIT	
$V_{OH}$	High-level output voltage	$V_{DD} = 3.3$ V, $I_{OH} = -3$ mA	$0.8 \times V_{DD}$			V	
		$V_{DD} = 1.8$ V, $I_{OH} = -2$ mA					
		$V_{DD} = 1.5$ V, $I_{OH} = -1$ mA					
		$V_{DD} = 0.9$ V, $I_{OH} = -0.4$ mA					
		$V_{DD} = 0.5$ V, $I_{OH} = -5$ $\mu\text{A}$	$0.7 \times V_{DD}$		V		
$V_{OL}$	Low-level output voltage	$V_{DD} = 3.3$ V, $I_{OL} = 3$ mA			0.3	V	
		$V_{DD} = 1.5$ V, $I_{OL} = 2$ mA					
		$V_{DD} = 1.2$ V, $I_{OL} = 1$ mA					
		$V_{DD} = 0.9$ V, $I_{OL} = 500$ $\mu\text{A}$					
$V_{OL}$	Low-level output voltage	RESET only	$V_{DD} = 0.4$ V, $I_{OL} = 5$ $\mu\text{A}$			0.1	V
$V_{IT-}$	Negative-going input threshold voltage <sup>(1)</sup>	TPS31xxE09	$T_A = +25^\circ\text{C}$	0.854	0.860	0.866	V
		TPS31xxE12		1.133	1.142	1.151	
		TPS31xxE15		1.423	1.434	1.445	
		TPS31xxE16		1.512	1.523	1.534	
		TPS31xxH20		1.829	1.843	1.857	
		TPS31xxK33		2.919	2.941	2.963	
$V_{IT-(S)}$	Negative-going input threshold voltage <sup>(1)</sup>	SENSE, PFI	$V_{DD} \geq 0.8$ V, $T_A = +25^\circ\text{C}$	0.542	0.551	0.559	V
$V_{HYS}$	Hysteresis at $V_{DD}$ input	$0.8$ V $\leq V_{IT} < 1.5$ V		20		mV	
		$1.6$ V $\leq V_{IT} < 2.4$ V		30			
		$2.5$ V $\leq V_{IT} < 3.3$ V		50			
$T_{(K)}$	Temperature coefficient of $V_{IT-}$ , PFI, SENSE	$T_A = -40^\circ\text{C}$ to $+85^\circ\text{C}$		-0.012	-0.019	%/K	
$V_{HYS}$	Hysteresis at SENSE, PFI input	$V_{DD} \geq 0.8$ V		15		mV	
$I_{IH}$	High-level input current	$\overline{MR}$	$\overline{MR} = V_{DD}$ , $V_{DD} = 3.3$ V	-25		25	nA
		SENSE, PFI, WDI	SENSE, PFI, WDI = $V_{DD}$ , $V_{DD} = 3.3$ V	-25		25	

(1) To ensure the best stability of the threshold voltage, a bypass capacitor (ceramic, 0.1  $\mu\text{F}$ ) should be placed close to the supply terminals.

## ELECTRICAL CHARACTERISTICS (continued)

over operating free-air temperature range (unless otherwise noted)

PARAMETER		TEST CONDITIONS	MIN	TYP	MAX	UNIT	
I <sub>IL</sub>	Low-level input current	$\overline{MR}$	$\overline{MR} = 0\text{ V}$ , $V_{DD} = 3.3\text{ V}$	-47	-33	-25	μA
		SENSE, PFI, WDI	SENSE, PFI, WDI = 0 V, $V_{DD} = 3.3\text{ V}$	-25		25	nA
I <sub>OH</sub>	High-level output current at RESET <sup>(2)</sup>	Open-drain	$V_{DD} = V_{IT} + 0.2\text{ V}$ , $V_{OH} = 3.3\text{ V}$			200	nA
I <sub>DD</sub>	Supply current		$V_{DD} > V_{IT}$ (average current), $V_{DD} < 1.8\text{ V}$		1.2	3	μA
			$V_{DD} > V_{IT}$ (average current), $V_{DD} > 1.8\text{ V}$		2	4.5	
			$V_{DD} < V_{IT}$ , $V_{DD} < 1.8\text{ V}$			22	
			$V_{DD} < V_{IT}$ , $V_{DD} > 1.8\text{ V}$			27	
	Internal pull-up resistor at $\overline{MR}$		70	100	130	kΩ	
C <sub>I</sub>	Input capacitance at $\overline{MR}$ , SENSE, PFI, WDI	$V_I = 0\text{ V}$ to $V_{DD}$		1		pF	

(2) Also refers to  $\overline{RSTVDD}$  and  $\overline{RSTSENSE}$ .

## SWITCHING CHARACTERISTICS

At  $R_L = 1\text{ M}\Omega$ ,  $C_L = 50\text{ pF}$ , and  $T_A = -40^\circ\text{C}$  to  $+85^\circ\text{C}$ , unless otherwise noted.

PARAMETER		TEST CONDITIONS	MIN	TYP	MAX	UNIT
t <sub>D</sub>	Delay time	$V_{DD} \geq 1.1 \times V_{IT}$ , $\overline{MR} = 0.7 \times V_{DD}$ , See <a href="#">Timing Diagrams</a>	65	130	195	ms
t <sub>PHL</sub>	Propagation delay time, high-to-low level output	$V_{DD}$ to $\overline{RESET}$ or $\overline{RSTVDD}$ delay			40	μs
t <sub>PLH</sub>	Propagation delay time, low-to-high level output	$V_{DD}$ to $\overline{RESET}$ or $\overline{RSTVDD}$ delay			40	μs
t <sub>PHL</sub>	Propagation delay time, high-to-low level output	SENSE to $\overline{RESET}$ or $\overline{RSTSENSE}$ delay	$V_{DD} \geq 0.8\text{ V}$ , $V_{IH} = 1.1 \times V_{IT}$ , $V_{IL} = 0.9 \times V_{IT}$		40	μs
t <sub>PLH</sub>	Propagation delay time, high-to-low level output	SENSE to $\overline{RESET}$ or $\overline{RSTSENSE}$ delay	$V_{DD} \geq 0.8\text{ V}$ , $V_{IH} = 1.1 \times V_{IT}$ , $V_{IL} = 0.9 \times V_{IT}$		40	μs
t <sub>PHL</sub>	Propagation delay time, high-to-low level output	PFI to $\overline{PFO}$ delay	$V_{DD} \geq 0.8\text{ V}$ , $V_{IH} = 1.1 \times V_{IT}$ , $V_{IL} = 0.9 \times V_{IT}$		40	μs
t <sub>PLH</sub>	Propagation delay time, low-to-high level output	PFI to $\overline{PFO}$ delay	$V_{DD} \geq 0.8\text{ V}$ , $V_{IH} = 1.1 \times V_{IT}$ , $V_{IL} = 0.9 \times V_{IT}$		300	μs
t <sub>PHL</sub>	Propagation delay time, low-to-high level output	$\overline{MR}$ to $\overline{RESET}$ . $\overline{RSTVDD}$ , $\overline{RSTSENSE}$ delay	$V_{DD} \geq 1.1 \times V_{IT}$ , $V_{IL} = 0.3 \times V_{DD}$ , $V_{IH} = 0.7 \times V_{DD}$	1	5	μs
t <sub>PLH</sub>	Propagation delay time, low-to-high level output	$\overline{MR}$ to $\overline{RESET}$ . $\overline{RSTVDD}$ , $\overline{RSTSENSE}$ delay	$V_{DD} \geq 1.1 \times V_{IT}$ , $V_{IL} = 0.3 \times V_{DD}$ , $V_{IH} = 0.7 \times V_{DD}$	1	5	μs

## TIMING REQUIREMENTS

At  $R_L = 1\text{ M}\Omega$ ,  $C_L = 50\text{ pF}$ , and  $T_A = -40^\circ\text{C}$  to  $+85^\circ\text{C}$ , unless otherwise noted.

PARAMETER		TEST CONDITIONS	MIN	TYP	MAX	UNIT	
t <sub>T(OUT)</sub>	Time-out period	at WDI	$V_{DD} \geq 0.85\text{ V}$	0.55	1.1	1.65	s
t <sub>W</sub>	Pulse width	at $V_{DD}$	$V_{IH} = 1.1 \times V_{IT}$ , $V_{IL} = 0.9 \times V_{IT-}$ , $V_{IT-} = 0.86\text{ V}$	20			μs
		at $\overline{MR}$	$V_{DD} \geq V_{IT} + 0.2\text{ V}$ , $V_{IL} = 0.3 \times V_{DD}$ , $V_{IH} = 0.7 \times V_{DD}$	0.1			
		at SENSE	$V_{DD} \geq V_{IT}$ , $V_{IH} = 1.1 \times V_{IT-(S)}$ , $V_{IL} = 0.9 \times V_{IT-(S)}$	20			
		at PFI	$V_{DD} \geq 0.85\text{ V}$ , $V_{IH} = 1.1 \times V_{IT-(S)}$ , $V_{IL} = 0.9 \times V_{IT-(S)}$	20			
		at WDI	$V_{DD} \geq V_{IT}$ , $V_{IL} = 0.3 \times V_{DD}$ , $V_{IH} = 0.7 \times V_{DD}$	0.3			

**FUNCTIONAL BLOCK DIAGRAMS**

**TPS3103**

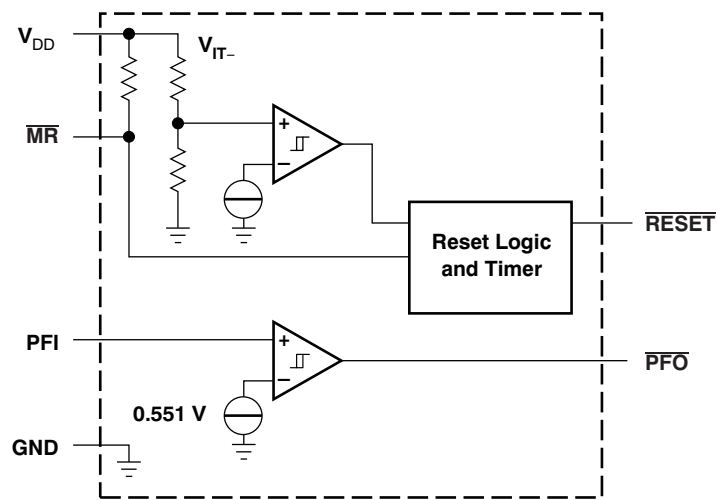

**TPS3106**

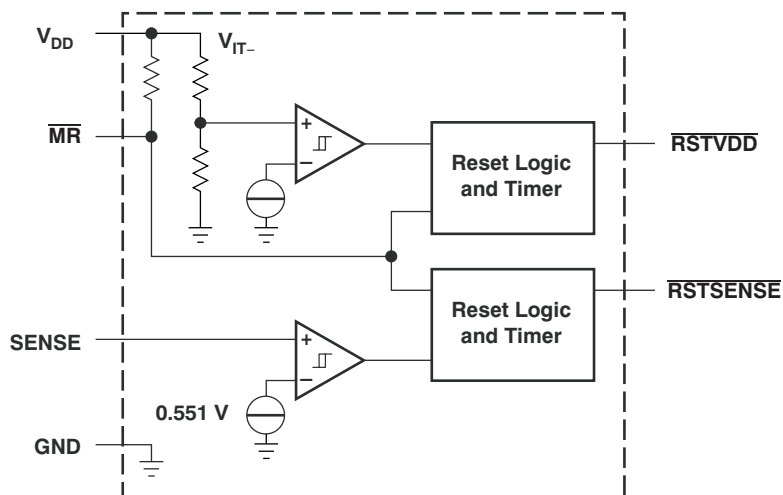

FUNCTIONAL BLOCK DIAGRAMS (continued)

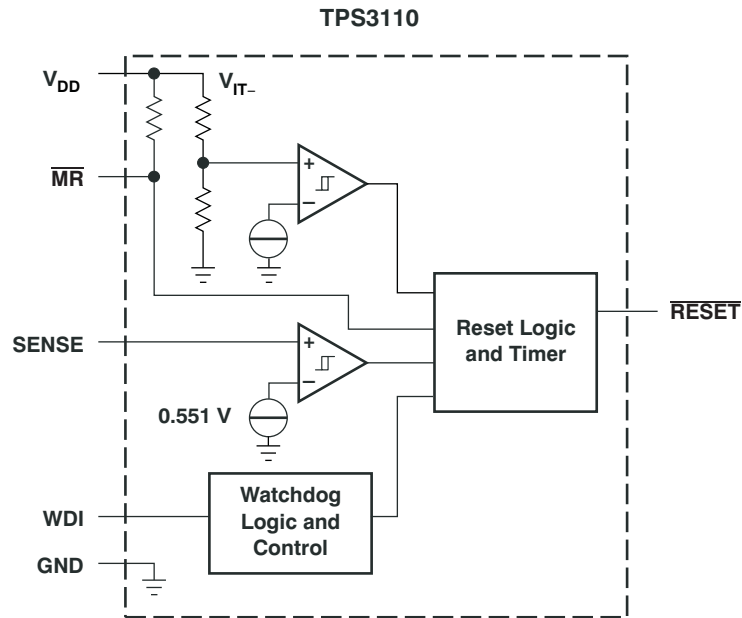

Table 1. TPS3103 FUNCTION TABLE

MR	$V_{(PFI)} > 0.551 \text{ V}$	$V_{DD} > V_{IT}$	RESET	PFO
L	0	X <sup>(1)</sup>	L	L
L	1	X	L	H
H	0	0	L	L
H	0	1	H	L
H	1	0	L	H
H	1	1	H	H

(1) X = Don't care.

Table 2. TPS3106 FUNCTION TABLE

MR	$V_{(SENSE)} > 0.551 \text{ V}$	$V_{DD} > V_{IT}$	RSTVDD	RSTSENSE
L	X <sup>(1)</sup>	X	L	L
H	0	0	L	L
H	0	1	H	L
H	1	0	L	H
H	1	1	H	H

(1) X = Don't care.

Table 3. TPS3110 FUNCTION TABLE<sup>(1)</sup>

MR	$V_{(SENSE)} > 0.551 \text{ V}$	$V_{DD} > V_{IT}$	RESET
L	X <sup>(2)</sup>	X	L
H	0	0	L
H	0	1	L
H	1	0	L
H	1	1	H

(1) Function of watchdog-timer not shown.

(2) X = Don't care.

## PIN DESCRIPTIONS

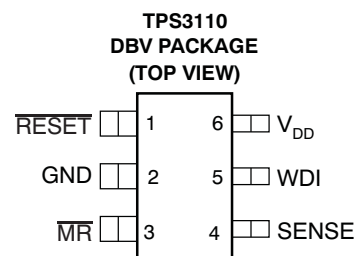
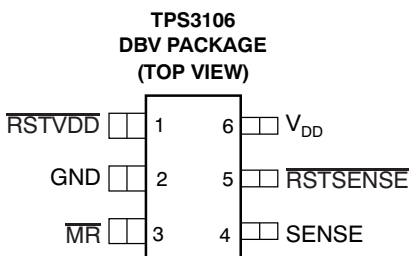
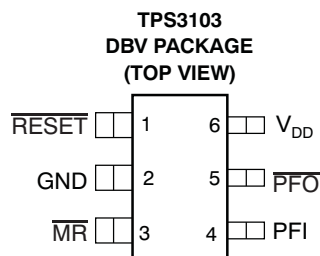

## TERMINAL FUNCTIONS

TERMINAL			DESCRIPTION
NAME	DEVICE	NO.	
GND	ALL	2	GND
MR	ALL	3	Manual-reset input. Pull low to force a reset. <b>RESET</b> remains low as long as <b>MR</b> is low and for the timeout period after <b>MR</b> goes high. Leave unconnected or connect to V <sub>DD</sub> when unused.
PFI	TPS3103	4	Power-fail input compares to 0.551 V with no additional delay. Connect to V <sub>DD</sub> if not used.
PFO	TPS3103	5	Power-fail output. Goes high when voltage at PFI rises above 0.551 V.
RESET	TPS3103, TPS3110	1	Active-low reset output. Either push-pull or open-drain output stage.
RSTSENSE	TPS3106	5	Active-low reset output. Logic level at <b>RSTSENSE</b> only depends on the voltage at <b>SENSE</b> and the status of <b>MR</b> .
RSTVDD	TPS3106	1	Active-low reset output. Logic level at <b>RSTVDD</b> only depends on the voltage at V <sub>DD</sub> and the status of <b>MR</b> .
SENSE	TPS3106, TPS3110	4	A reset will be asserted if the voltage at <b>SENSE</b> is lower than 0.551 V. Connect to V <sub>DD</sub> if unused.
V <sub>DD</sub>	ALL	6	Supply voltage. Powers the device and monitors its own voltage.
WDI	TPS3110	5	Watchdog timer input. If <b>WDI</b> remains high or low longer than the time-out period, then reset is triggered. The timer clears when reset is asserted or when <b>WDI</b> sees a rising edge or a falling edge.

TIMING DIAGRAMS

Timing Diagrams for TPS3103

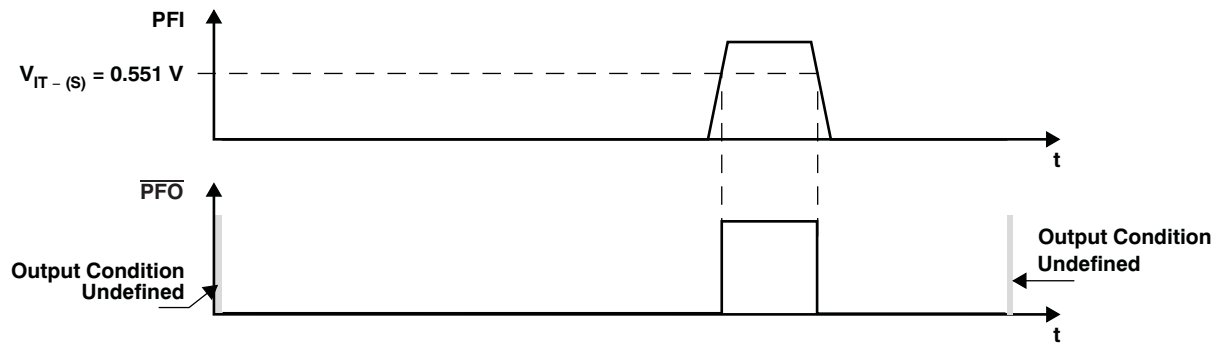
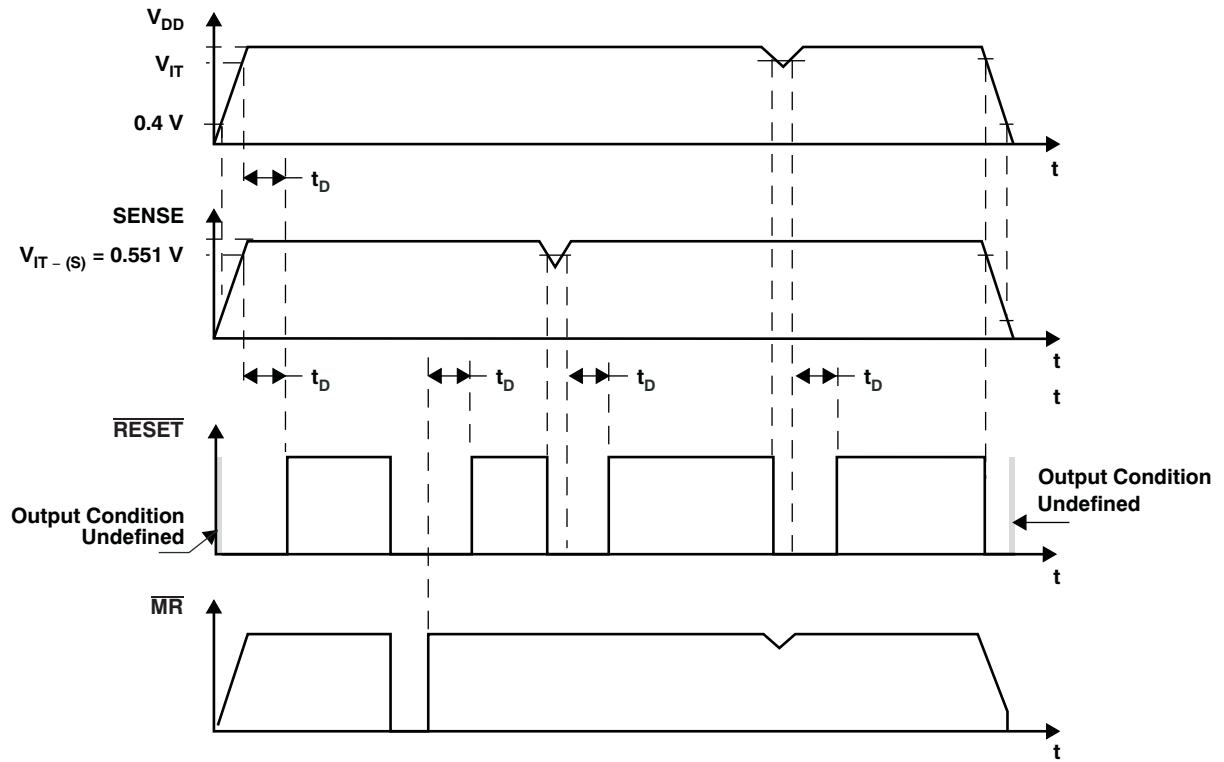

**TIMING DIAGRAMS (continued)**

**Timing Diagram for TPS3106**

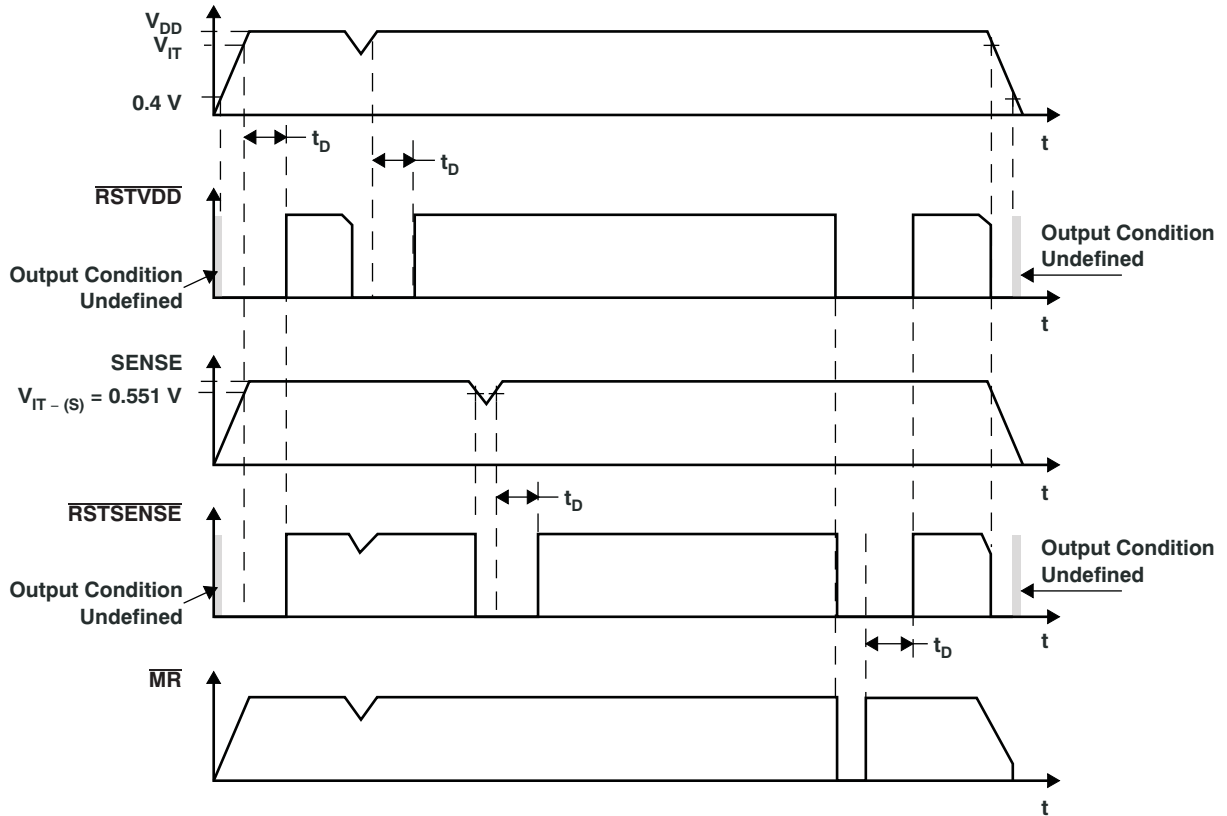

TIMING DIAGRAMS (continued)

Timing Diagram for TPS3110

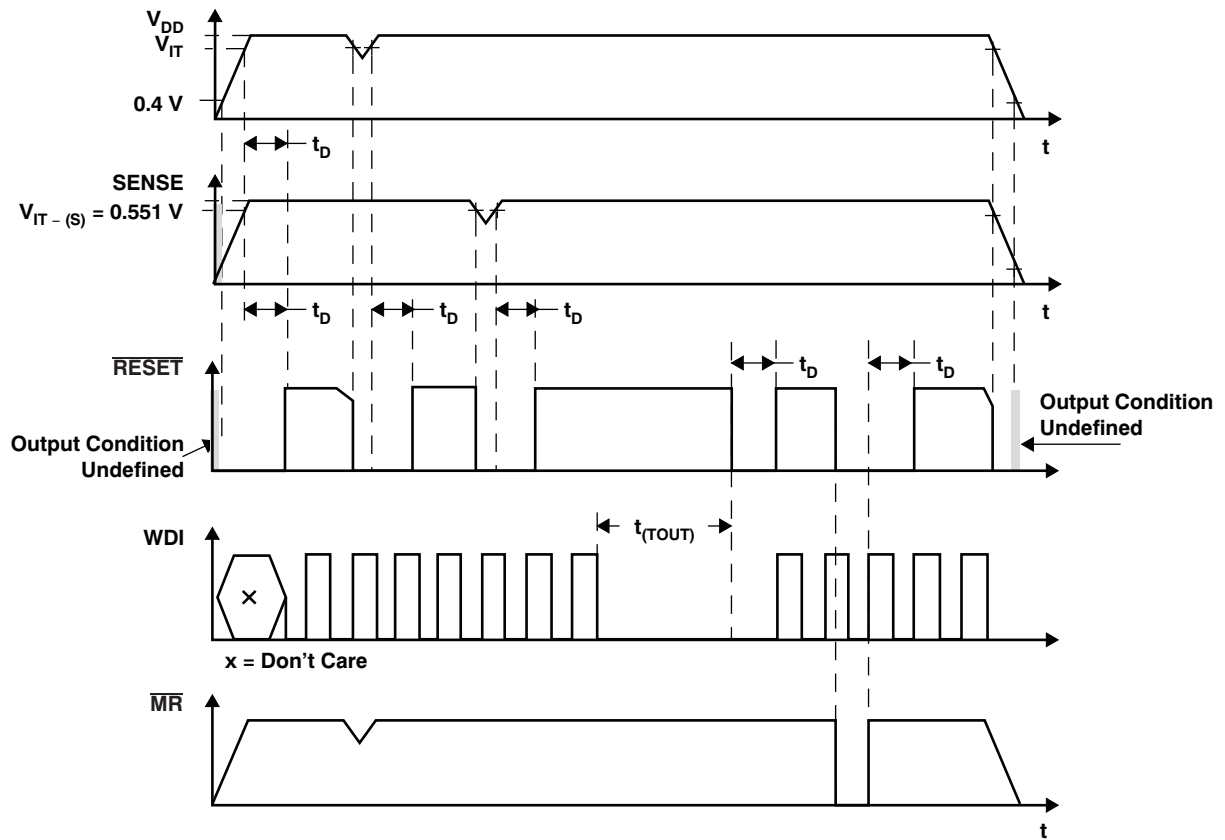

**TYPICAL CHARACTERISTICS**

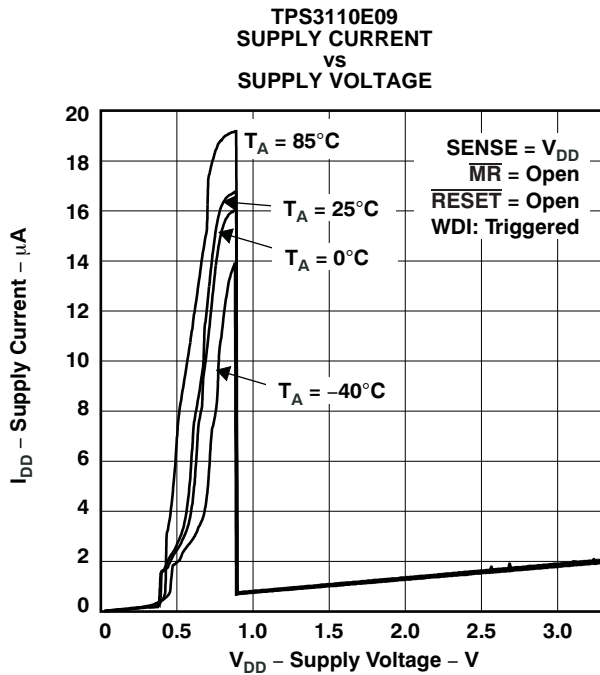

Figure 1.

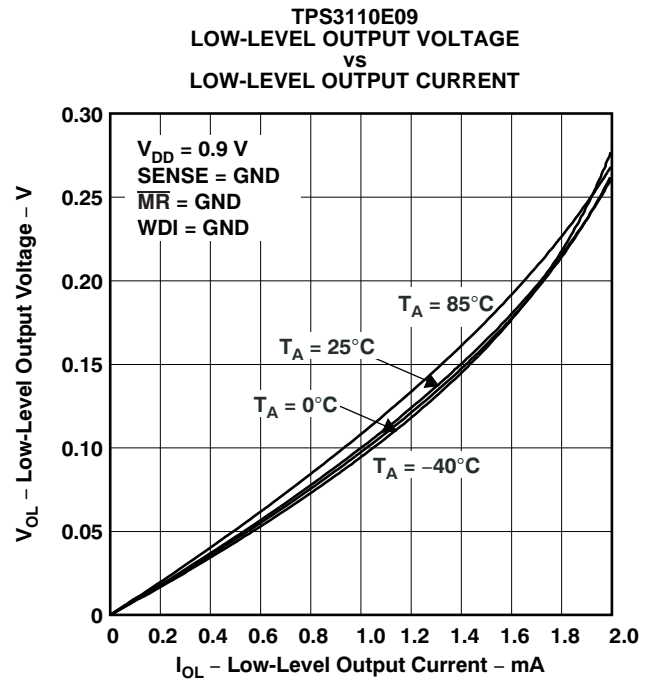

Figure 2.

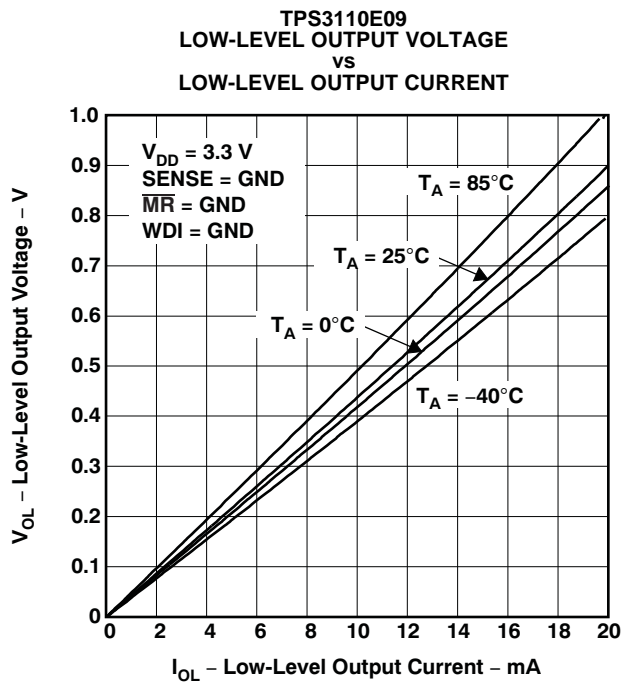

Figure 3.

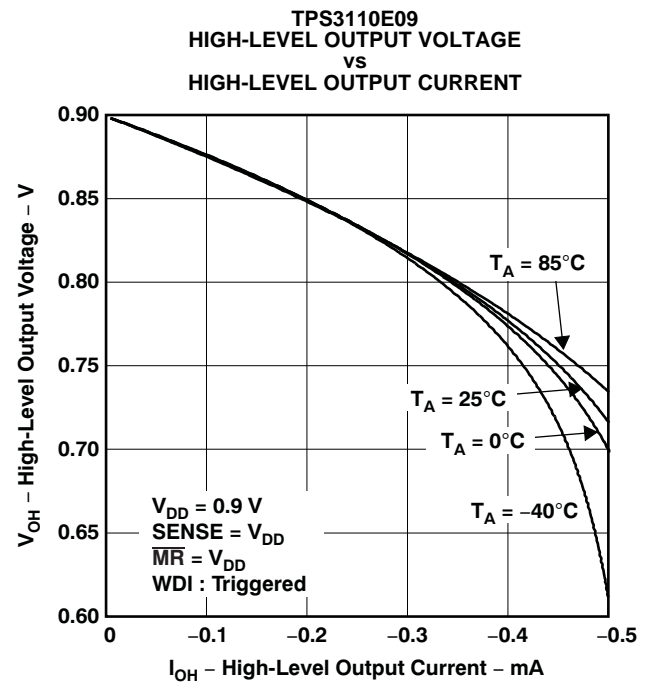

Figure 4.

TYPICAL CHARACTERISTICS (continued)

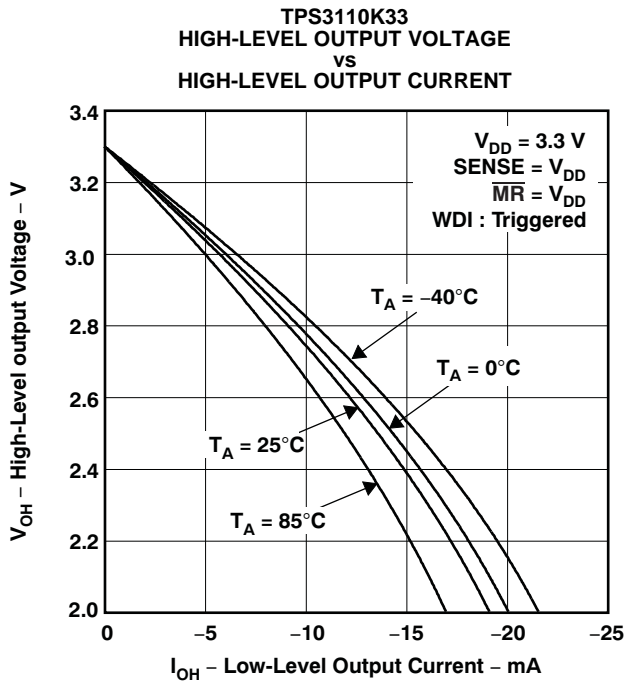

Figure 5.

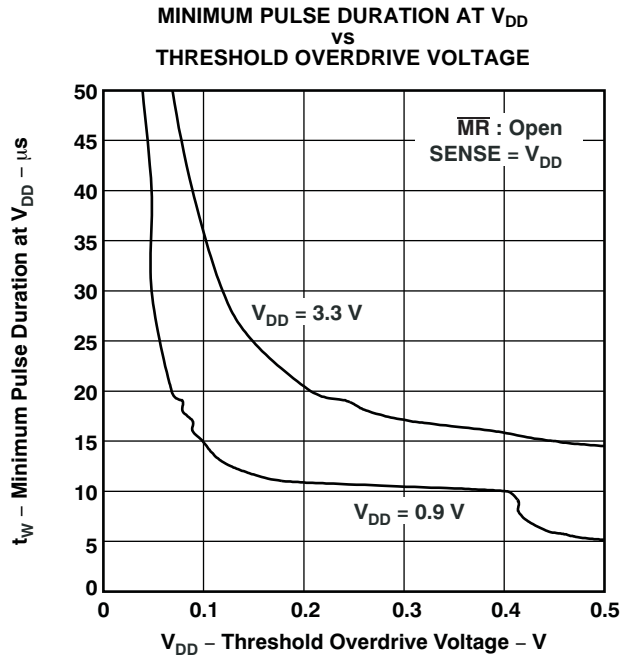

Figure 6.

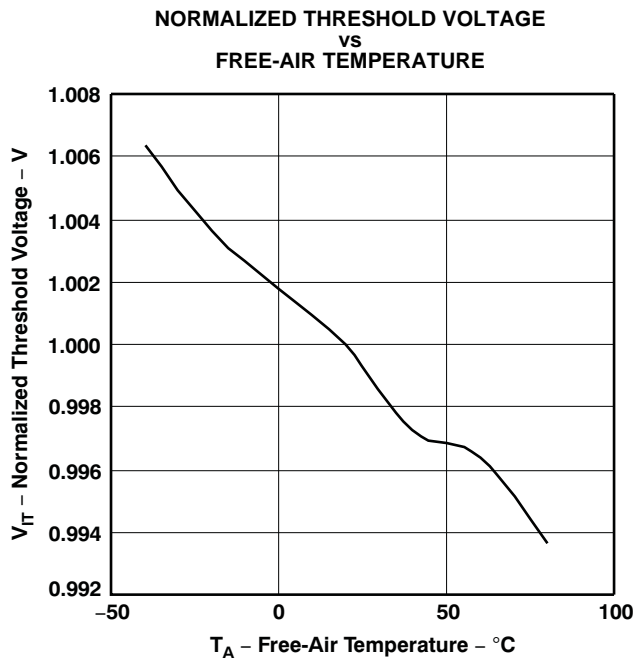

Figure 7.

## APPLICATION INFORMATION

The TPS31xx family has a quiescent current in the 1- $\mu$ A to 2- $\mu$ A range. When  $\overline{\text{RESET}}$  is active, triggered by the voltage monitored at  $V_{\text{DD}}$ , the quiescent current increases to about 20  $\mu$ A (see the [Electrical Characteristics](#)).

In some applications it is necessary to minimize the quiescent current even during the reset period. This is especially true when the voltage of a battery is supervised and the  $\overline{\text{RESET}}$  is used to shut down the system or for an early warning. In this case the reset condition will last for a longer period of time. The current drawn from the battery should almost be zero, especially when the battery is discharged.

For this kind of application, either the TPS3103 or TPS3106 is a good fit. To minimize current consumption, select a version where the threshold voltage is lower than the voltage monitored at  $V_{\text{DD}}$ . The TPS3106 has two reset outputs. One output ( $\overline{\text{RSTVDD}}$ ) is triggered from the voltage monitored at  $V_{\text{DD}}$ . The other output ( $\overline{\text{RSTSENSE}}$ ) is triggered from the voltage monitored at SENSE. In the application shown in [Figure 8](#), the TPS3106E09 is used to monitor the input voltage of two NiCd or NiMH cells. The threshold voltage ( $V_{\text{TH}} = 0.86$  V) was chosen as low as possible to ensure that the supply voltage is always higher than the threshold voltage at  $V_{\text{DD}}$ . The voltage of the battery is monitored using the SENSE input. The voltage divider was calculated to assert a reset using the  $\overline{\text{RSTSENSE}}$  output at  $2 \times 0.8$  V = 1.6 V.

$$R1 = R2 \times \left( \frac{V_{\text{TRIP}}}{V_{\text{IT(S)}}} - 1 \right) \quad (1)$$

where:

$V_{\text{TRIP}}$  is the voltage of the battery at which a reset is asserted and

$V_{\text{IT(S)}}$  is the threshold voltage at SENSE = 0.551 V.

R1 was chosen for a resistor current in the 1- $\mu$ A range.

With  $V_{\text{TRIP}} = 1.6$  V:

$$R1 \approx 1.9 \times R2$$

$$R1 = 820 \text{ k}\Omega, R2 = 430 \text{ k}\Omega$$

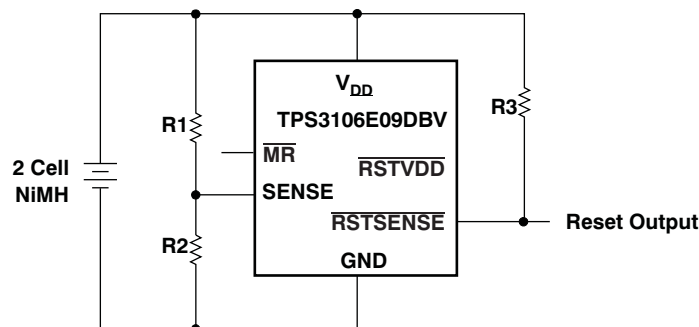

**Figure 8. Battery Monitoring with 3- $\mu$ A Supply Current for Device and Resistor Divider**

## APPLICATION INFORMATION (continued)

### WATCHDOG

The TPS3110 device integrates a watchdog timer that must be periodically triggered by a positive or negative transition of WDI. When the supervising system fails to retrigger the watchdog circuit within the time-out interval,  $\overline{\text{RESET}}$  becomes active for the time period ( $t_D$ ). This event also reinitializes the watchdog timer.

### MANUAL RESET ( $\overline{\text{MR}}$ )

Many  $\mu\text{C}$ -based products require manual-reset capability, allowing an operator or logic circuitry to initiate a reset. Logic low at  $\overline{\text{MR}}$  asserts reset. Reset remains asserted while  $\overline{\text{MR}}$  is low and for a time period ( $t_D$ ) after  $\overline{\text{MR}}$  returns high. The input has an internal 100-k $\Omega$  pull-up resistor, so it can be left open if it is unused.

Connect a normally open momentary switch from  $\overline{\text{MR}}$  to GND to create a manual reset function. External debounce is not required. If  $\overline{\text{MR}}$  is driven from long cables or if the device is used in noisy environments, connecting a 0.1- $\mu\text{F}$  capacitor from  $\overline{\text{MR}}$  to GND provides additional noise immunity.

If there is a possibility of transient or DC conditions causing  $\overline{\text{MR}}$  to rise above  $V_{\text{DD}}$ , a diode should be used to limit  $\overline{\text{MR}}$  to a diode drop above  $V_{\text{DD}}$ .

### PFI, $\overline{\text{PFO}}$

The TPS3103 has an integrated power-fail (PFI) comparator with a separate open-drain ( $\overline{\text{PFO}}$ ) output. The PFI and  $\overline{\text{PFO}}$  can be used for low-battery detection, power-fail warning, or for monitoring a power supply other than the main supply, and has no effect on  $\overline{\text{RESET}}$ .

An additional comparator is provided to monitor voltages other than the nominal supply voltage. The power-fail input (PFI) will be compared with an internal voltage reference of 0.551 V. If the input voltage falls below the power-fail threshold ( $V_{\text{IT} - (\text{S})}$ ), the power-fail output ( $\overline{\text{PFO}}$ ) goes low. If it goes above 0.551 V plus approximately 15-mV hysteresis, the output returns to high. By connecting two external resistors, it is possible to supervise any voltage above 0.551 V. The sum of both resistors should be approximately 1 M $\Omega$ , to minimize power consumption and to assure that the current into the PFI pin can be neglected, compared with the current through the resistor network. The tolerance of the external resistors should be not more than 1% to ensure minimal variation of sensed voltage. If the power-fail comparator is unused, connect PFI to GND and leave  $\overline{\text{PFO}}$  unconnected. For proper operation of the PFI-comparator, the supply voltage ( $V_{\text{DD}}$ ) must be higher than 0.8 V.

### SENSE

The voltage at the SENSE input is compared with a reference voltage of 0.551 V. If the voltage at SENSE falls below the sense-threshold ( $V_{\text{IT} - (\text{S})}$ ), reset is asserted. On the TPS3106, a dedicated  $\overline{\text{RSTSENSE}}$  output is available. On the TPS3110, the logic signal from SENSE is OR-wired with the logic signal from  $V_{\text{DD}}$  or  $\overline{\text{MR}}$ . An internal timer delays the return of the output to the inactive state, once the voltage at SENSE goes above 0.551 V plus about 15 mV of hysteresis. For proper operation of the SENSE-comparator, the supply voltage must be higher than 0.8 V.

APPLICATION INFORMATION (continued)

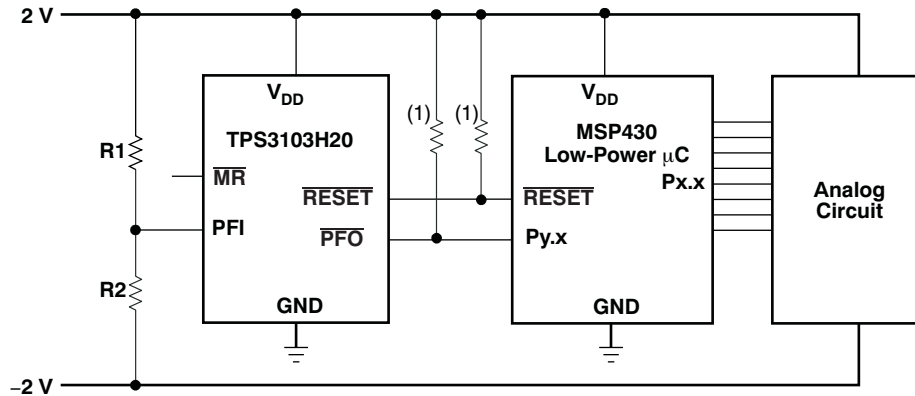

$$V_{(NEG\_TH)} = 0.551 \text{ V} - \frac{R_2}{R_1} (V_{DD} - 0.551 \text{ V})$$

(1) Resistor may be integrated in  $\mu\text{C}$ .

Figure 9. TPS3103 Monitoring a Negative Voltage

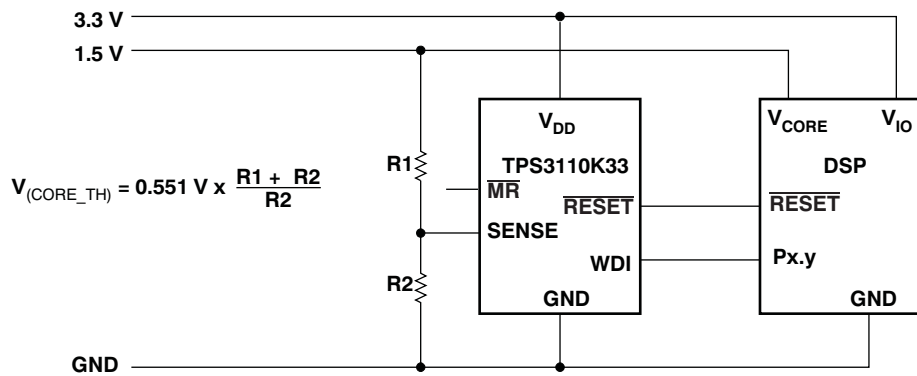

$$V_{(CORE\_TH)} = 0.551 \text{ V} \times \frac{R_1 + R_2}{R_2}$$

Figure 10. TPS3110 in a DSP-System Monitoring Both Supply Voltages

**PACKAGING INFORMATION**

Orderable Device	Status <sup>(1)</sup>	Package Type	Package Drawing	Pins	Package Qty	Eco Plan <sup>(2)</sup>	Lead/Ball Finish	MSL Peak Temp <sup>(3)</sup>
SN0402002DBVR	ACTIVE	SOT-23	DBV	6	3000	Green (RoHS & no Sb/Br)	CU NIPDAU	Level-1-260C-UNLIM
TPS3103E12DBVR	ACTIVE	SOT-23	DBV	6	3000	Green (RoHS & no Sb/Br)	CU NIPDAU	Level-1-260C-UNLIM
TPS3103E12DBVRG4	ACTIVE	SOT-23	DBV	6	3000	Green (RoHS & no Sb/Br)	CU NIPDAU	Level-1-260C-UNLIM
TPS3103E12DBVT	ACTIVE	SOT-23	DBV	6	250	Green (RoHS & no Sb/Br)	CU NIPDAU	Level-1-260C-UNLIM
TPS3103E12DBVTG4	ACTIVE	SOT-23	DBV	6	250	Green (RoHS & no Sb/Br)	CU NIPDAU	Level-1-260C-UNLIM
TPS3103E15DBVR	ACTIVE	SOT-23	DBV	6	3000	Green (RoHS & no Sb/Br)	CU NIPDAU	Level-1-260C-UNLIM
TPS3103E15DBVRG4	ACTIVE	SOT-23	DBV	6	3000	Green (RoHS & no Sb/Br)	CU NIPDAU	Level-1-260C-UNLIM
TPS3103E15DBVT	ACTIVE	SOT-23	DBV	6	250	Green (RoHS & no Sb/Br)	CU NIPDAU	Level-1-260C-UNLIM
TPS3103E15DBVTG4	ACTIVE	SOT-23	DBV	6	250	Green (RoHS & no Sb/Br)	CU NIPDAU	Level-1-260C-UNLIM
TPS3103H20DBVR	ACTIVE	SOT-23	DBV	6	3000	Green (RoHS & no Sb/Br)	CU NIPDAU	Level-1-260C-UNLIM
TPS3103H20DBVRG4	ACTIVE	SOT-23	DBV	6	3000	Green (RoHS & no Sb/Br)	CU NIPDAU	Level-1-260C-UNLIM
TPS3103H20DBVT	ACTIVE	SOT-23	DBV	6	250	Green (RoHS & no Sb/Br)	CU NIPDAU	Level-1-260C-UNLIM
TPS3103H20DBVTG4	ACTIVE	SOT-23	DBV	6	250	Green (RoHS & no Sb/Br)	CU NIPDAU	Level-1-260C-UNLIM
TPS3103K33DBVR	ACTIVE	SOT-23	DBV	6	3000	Green (RoHS & no Sb/Br)	CU NIPDAU	Level-1-260C-UNLIM
TPS3103K33DBVRG4	ACTIVE	SOT-23	DBV	6	3000	Green (RoHS & no Sb/Br)	CU NIPDAU	Level-1-260C-UNLIM
TPS3103K33DBVT	ACTIVE	SOT-23	DBV	6	250	Green (RoHS & no Sb/Br)	CU NIPDAU	Level-1-260C-UNLIM
TPS3103K33DBVTG4	ACTIVE	SOT-23	DBV	6	250	Green (RoHS & no Sb/Br)	CU NIPDAU	Level-1-260C-UNLIM
TPS3106E09DBVR	ACTIVE	SOT-23	DBV	6	3000	Green (RoHS & no Sb/Br)	CU NIPDAU	Level-1-260C-UNLIM
TPS3106E09DBVRG4	ACTIVE	SOT-23	DBV	6	3000	Green (RoHS & no Sb/Br)	CU NIPDAU	Level-1-260C-UNLIM
TPS3106E09DBVT	ACTIVE	SOT-23	DBV	6	250	Green (RoHS & no Sb/Br)	CU NIPDAU	Level-1-260C-UNLIM
TPS3106E09DBVTG4	ACTIVE	SOT-23	DBV	6	250	Green (RoHS & no Sb/Br)	CU NIPDAU	Level-1-260C-UNLIM
TPS3106E16DBVR	ACTIVE	SOT-23	DBV	6	3000	Green (RoHS & no Sb/Br)	CU NIPDAU	Level-1-260C-UNLIM
TPS3106E16DBVRG4	ACTIVE	SOT-23	DBV	6	3000	Green (RoHS & no Sb/Br)	CU NIPDAU	Level-1-260C-UNLIM
TPS3106E16DBVT	ACTIVE	SOT-23	DBV	6	250	Green (RoHS & no Sb/Br)	CU NIPDAU	Level-1-260C-UNLIM
TPS3106E16DBVTG4	ACTIVE	SOT-23	DBV	6	250	Green (RoHS & no Sb/Br)	CU NIPDAU	Level-1-260C-UNLIM

Orderable Device	Status <sup>(1)</sup>	Package Type	Package Drawing	Pins	Package Qty	Eco Plan <sup>(2)</sup>	Lead/Ball Finish	MSL Peak Temp <sup>(3)</sup>
TPS3106K33DBVR	ACTIVE	SOT-23	DBV	6	3000	Green (RoHS & no Sb/Br)	CU NIPDAU	Level-1-260C-UNLIM
TPS3106K33DBVRG4	ACTIVE	SOT-23	DBV	6	3000	Green (RoHS & no Sb/Br)	CU NIPDAU	Level-1-260C-UNLIM
TPS3106K33DBVT	ACTIVE	SOT-23	DBV	6	250	Green (RoHS & no Sb/Br)	CU NIPDAU	Level-1-260C-UNLIM
TPS3106K33DBVTG4	ACTIVE	SOT-23	DBV	6	250	Green (RoHS & no Sb/Br)	CU NIPDAU	Level-1-260C-UNLIM
TPS3110E09DBVR	ACTIVE	SOT-23	DBV	6	3000	Green (RoHS & no Sb/Br)	CU NIPDAU	Level-1-260C-UNLIM
TPS3110E09DBVRG4	ACTIVE	SOT-23	DBV	6	3000	Green (RoHS & no Sb/Br)	CU NIPDAU	Level-1-260C-UNLIM
TPS3110E09DBVT	ACTIVE	SOT-23	DBV	6	250	Green (RoHS & no Sb/Br)	CU NIPDAU	Level-1-260C-UNLIM
TPS3110E09DBVTG4	ACTIVE	SOT-23	DBV	6	250	Green (RoHS & no Sb/Br)	CU NIPDAU	Level-1-260C-UNLIM
TPS3110E12DBVR	ACTIVE	SOT-23	DBV	6	3000	Green (RoHS & no Sb/Br)	CU NIPDAU	Level-1-260C-UNLIM
TPS3110E12DBVRG4	ACTIVE	SOT-23	DBV	6	3000	Green (RoHS & no Sb/Br)	CU NIPDAU	Level-1-260C-UNLIM
TPS3110E12DBVT	ACTIVE	SOT-23	DBV	6	250	Green (RoHS & no Sb/Br)	CU NIPDAU	Level-1-260C-UNLIM
TPS3110E12DBVTG4	ACTIVE	SOT-23	DBV	6	250	Green (RoHS & no Sb/Br)	CU NIPDAU	Level-1-260C-UNLIM
TPS3110E15DBVR	ACTIVE	SOT-23	DBV	6	3000	Green (RoHS & no Sb/Br)	CU NIPDAU	Level-1-260C-UNLIM
TPS3110E15DBVRG4	ACTIVE	SOT-23	DBV	6	3000	Green (RoHS & no Sb/Br)	CU NIPDAU	Level-1-260C-UNLIM
TPS3110E15DBVT	ACTIVE	SOT-23	DBV	6	250	Green (RoHS & no Sb/Br)	CU NIPDAU	Level-1-260C-UNLIM
TPS3110E15DBVTG4	ACTIVE	SOT-23	DBV	6	250	Green (RoHS & no Sb/Br)	CU NIPDAU	Level-1-260C-UNLIM
TPS3110K33DBVR	ACTIVE	SOT-23	DBV	6	3000	Green (RoHS & no Sb/Br)	CU NIPDAU	Level-1-260C-UNLIM
TPS3110K33DBVRG4	ACTIVE	SOT-23	DBV	6	3000	Green (RoHS & no Sb/Br)	CU NIPDAU	Level-1-260C-UNLIM
TPS3110K33DBVT	ACTIVE	SOT-23	DBV	6	250	Green (RoHS & no Sb/Br)	CU NIPDAU	Level-1-260C-UNLIM
TPS3110K33DBVTG4	ACTIVE	SOT-23	DBV	6	250	Green (RoHS & no Sb/Br)	CU NIPDAU	Level-1-260C-UNLIM

<sup>(1)</sup> The marketing status values are defined as follows:

**ACTIVE:** Product device recommended for new designs.

**LIFEBUY:** TI has announced that the device will be discontinued, and a lifetime-buy period is in effect.

**NRND:** Not recommended for new designs. Device is in production to support existing customers, but TI does not recommend using this part in a new design.

**PREVIEW:** Device has been announced but is not in production. Samples may or may not be available.

**OBSOLETE:** TI has discontinued the production of the device.

<sup>(2)</sup> Eco Plan - The planned eco-friendly classification: Pb-Free (RoHS), Pb-Free (RoHS Exempt), or Green (RoHS & no Sb/Br) - please check <http://www.ti.com/productcontent> for the latest availability information and additional product content details.

**TBD:** The Pb-Free/Green conversion plan has not been defined.

**Pb-Free (RoHS):** TI's terms "Lead-Free" or "Pb-Free" mean semiconductor products that are compatible with the current RoHS requirements for all 6 substances, including the requirement that lead not exceed 0.1% by weight in homogeneous materials. Where designed to be soldered

at high temperatures, TI Pb-Free products are suitable for use in specified lead-free processes.

**Pb-Free (RoHS Exempt):** This component has a RoHS exemption for either 1) lead-based flip-chip solder bumps used between the die and package, or 2) lead-based die adhesive used between the die and leadframe. The component is otherwise considered Pb-Free (RoHS compatible) as defined above.

**Green (RoHS & no Sb/Br):** TI defines "Green" to mean Pb-Free (RoHS compatible), and free of Bromine (Br) and Antimony (Sb) based flame retardants (Br or Sb do not exceed 0.1% by weight in homogeneous material)

<sup>(3)</sup> MSL, Peak Temp. -- The Moisture Sensitivity Level rating according to the JEDEC industry standard classifications, and peak solder temperature.

**Important Information and Disclaimer:**The information provided on this page represents TI's knowledge and belief as of the date that it is provided. TI bases its knowledge and belief on information provided by third parties, and makes no representation or warranty as to the accuracy of such information. Efforts are underway to better integrate information from third parties. TI has taken and continues to take reasonable steps to provide representative and accurate information but may not have conducted destructive testing or chemical analysis on incoming materials and chemicals. TI and TI suppliers consider certain information to be proprietary, and thus CAS numbers and other limited information may not be available for release.

In no event shall TI's liability arising out of such information exceed the total purchase price of the TI part(s) at issue in this document sold by TI to Customer on an annual basis.

DBV (R-PDSO-G6)

PLASTIC SMALL-OUTLINE PACKAGE

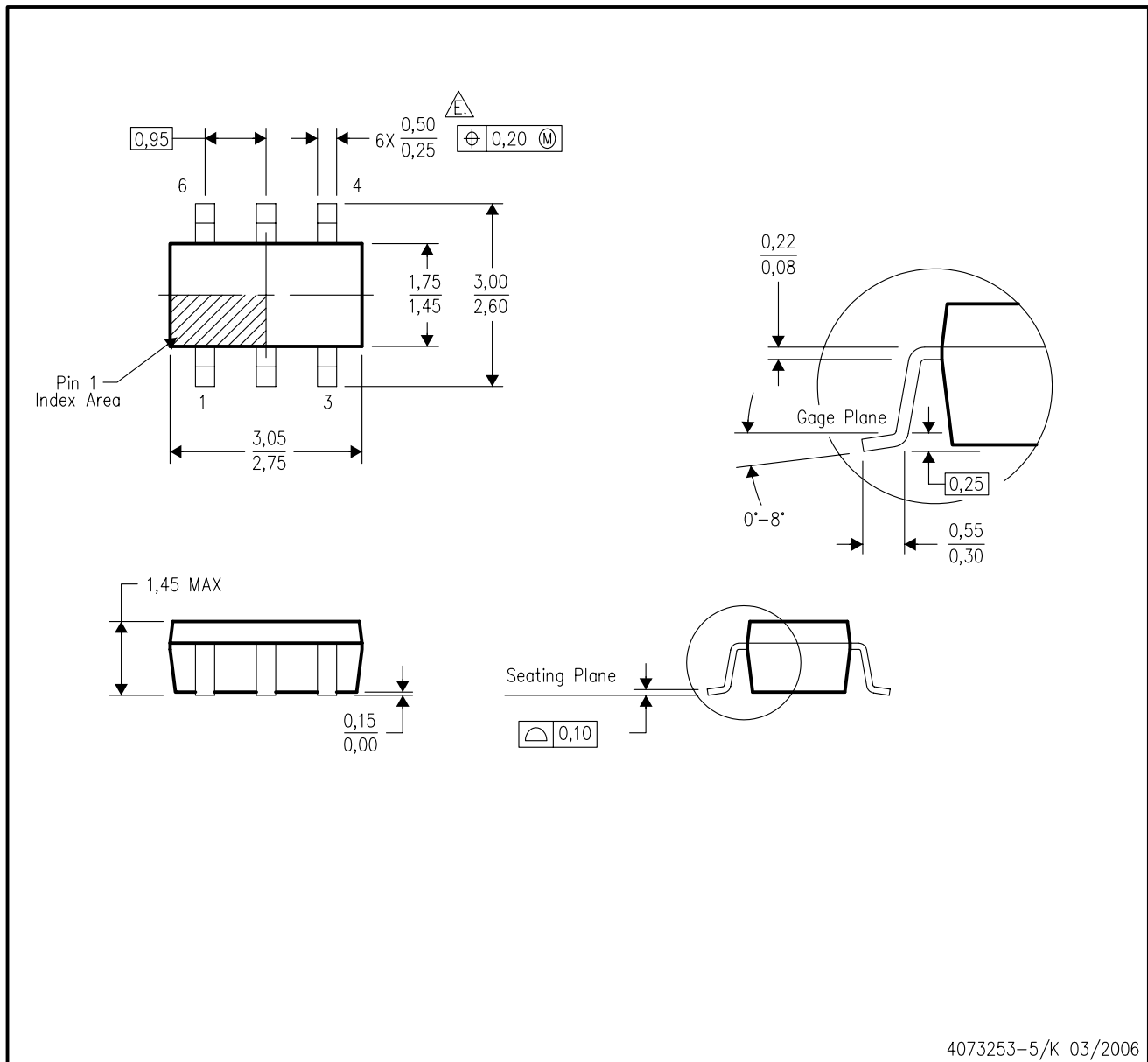

- NOTES:
- A. All linear dimensions are in millimeters.
  - B. This drawing is subject to change without notice.
  - C. Body dimensions do not include mold flash or protrusion. Mold flash and protrusion shall not exceed 0.15 per side.
  - D. Leads 1,2,3 may be wider than leads 4,5,6 for package orientation.
- $\triangle E$  Falls within JEDEC MO-178 Variation AB, except minimum lead width.

## IMPORTANT NOTICE

Texas Instruments Incorporated and its subsidiaries (TI) reserve the right to make corrections, modifications, enhancements, improvements, and other changes to its products and services at any time and to discontinue any product or service without notice. Customers should obtain the latest relevant information before placing orders and should verify that such information is current and complete. All products are sold subject to TI's terms and conditions of sale supplied at the time of order acknowledgment.

TI warrants performance of its hardware products to the specifications applicable at the time of sale in accordance with TI's standard warranty. Testing and other quality control techniques are used to the extent TI deems necessary to support this warranty. Except where mandated by government requirements, testing of all parameters of each product is not necessarily performed.

TI assumes no liability for applications assistance or customer product design. Customers are responsible for their products and applications using TI components. To minimize the risks associated with customer products and applications, customers should provide adequate design and operating safeguards.

TI does not warrant or represent that any license, either express or implied, is granted under any TI patent right, copyright, mask work right, or other TI intellectual property right relating to any combination, machine, or process in which TI products or services are used. Information published by TI regarding third-party products or services does not constitute a license from TI to use such products or services or a warranty or endorsement thereof. Use of such information may require a license from a third party under the patents or other intellectual property of the third party, or a license from TI under the patents or other intellectual property of TI.

Reproduction of information in TI data books or data sheets is permissible only if reproduction is without alteration and is accompanied by all associated warranties, conditions, limitations, and notices. Reproduction of this information with alteration is an unfair and deceptive business practice. TI is not responsible or liable for such altered documentation.

Resale of TI products or services with statements different from or beyond the parameters stated by TI for that product or service voids all express and any implied warranties for the associated TI product or service and is an unfair and deceptive business practice. TI is not responsible or liable for any such statements.

Following are URLs where you can obtain information on other Texas Instruments products and application solutions:

### Products

Amplifiers	<a href="http://amplifier.ti.com">amplifier.ti.com</a>
Data Converters	<a href="http://dataconverter.ti.com">dataconverter.ti.com</a>
DSP	<a href="http://dsp.ti.com">dsp.ti.com</a>
Interface	<a href="http://interface.ti.com">interface.ti.com</a>
Logic	<a href="http://logic.ti.com">logic.ti.com</a>
Power Mgmt	<a href="http://power.ti.com">power.ti.com</a>
Microcontrollers	<a href="http://microcontroller.ti.com">microcontroller.ti.com</a>
Low Power Wireless	<a href="http://www.ti.com/lpw">www.ti.com/lpw</a>

### Applications

Audio	<a href="http://www.ti.com/audio">www.ti.com/audio</a>
Automotive	<a href="http://www.ti.com/automotive">www.ti.com/automotive</a>
Broadband	<a href="http://www.ti.com/broadband">www.ti.com/broadband</a>
Digital Control	<a href="http://www.ti.com/digitalcontrol">www.ti.com/digitalcontrol</a>
Military	<a href="http://www.ti.com/military">www.ti.com/military</a>
Optical Networking	<a href="http://www.ti.com/opticalnetwork">www.ti.com/opticalnetwork</a>
Security	<a href="http://www.ti.com/security">www.ti.com/security</a>
Telephony	<a href="http://www.ti.com/telephony">www.ti.com/telephony</a>
Video & Imaging	<a href="http://www.ti.com/video">www.ti.com/video</a>
Wireless	<a href="http://www.ti.com/wireless">www.ti.com/wireless</a>

Mailing Address: Texas Instruments  
Post Office Box 655303 Dallas, Texas 75265