

# TPIC6595 POWER LOGIC 8-BIT SHIFT REGISTER

SLIS010B – APRIL 1992 – REVISED MAY 2005

- Low  $r_{DS(on)}$  . . . 1.3  $\Omega$  Typical
- Avalanche Energy . . . 75 mJ
- Eight Power DMOS Transistor Outputs of 250-mA Continuous Current
- 1.5-A Pulsed Current Per Output
- Output Clamp Voltage at 45 V
- Devices Are Cascadable
- Low Power Consumption

## description

The TPIC6595 is a monolithic, high-voltage, high-current power 8-bit shift register designed for use in systems that require relatively high load power. The device contains a built-in voltage clamp on the outputs for inductive transient protection. Power driver applications include relays, solenoids, and other medium-current or high-voltage loads.

This device contains an 8-bit serial-in, parallel-out shift register that feeds an 8-bit D-type storage register. Data transfers through both the shift and storage registers on the rising edge of the shift-register clock (SRCK) and the register clock (RCK) respectively. The storage register transfers data to the output buffer when shift-register clear (SRCLR) is high. When SRCLR is low, the input shift register is cleared. When output enable ( $\bar{G}$ ) is held high, all data in the output buffers is held low and all drain outputs are off. When  $\bar{G}$  is held low, data from the storage register is transparent to the output buffers. The serial output (SER OUT) allows for cascading of the data from the shift register to additional devices.

Outputs are low-side, open-drain DMOS transistors with output ratings of 45 V and 250-mA continuous sink current capability. When data in the output buffers is low, the DMOS-transistor outputs are off. When data is high, the DMOS-transistor outputs have sink current capability.

Separate power and logic level ground pins are provided to facilitate maximum system flexibility. Pins 1, 10, 11, and 20 are internally connected, and each pin must be externally connected to the power system ground in order to minimize parasitic inductance. A single-point connection between pin 19, logic ground (LGND), and pins 1, 10, 11, and 20, power grounds (PGND), must be externally made in a manner that reduces crosstalk between the logic and load circuits.

The TPIC6595 is characterized for operation over the operating case temperature range of  $-40^{\circ}\text{C}$  to  $125^{\circ}\text{C}$ .

DW OR N PACKAGE  
(TOP VIEW)

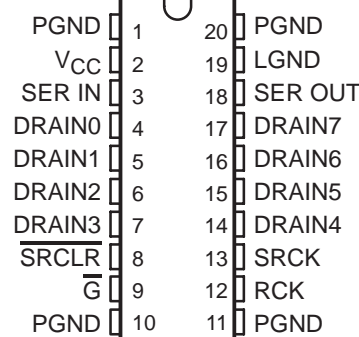

## logic symbol†

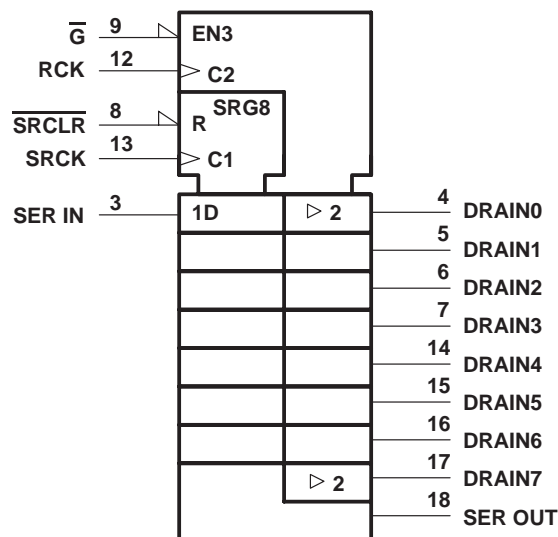

† This symbol is in accordance with ANSI/IEEE Std 91-1984 and IEC Publication 617-12.



**schematic of inputs and outputs**

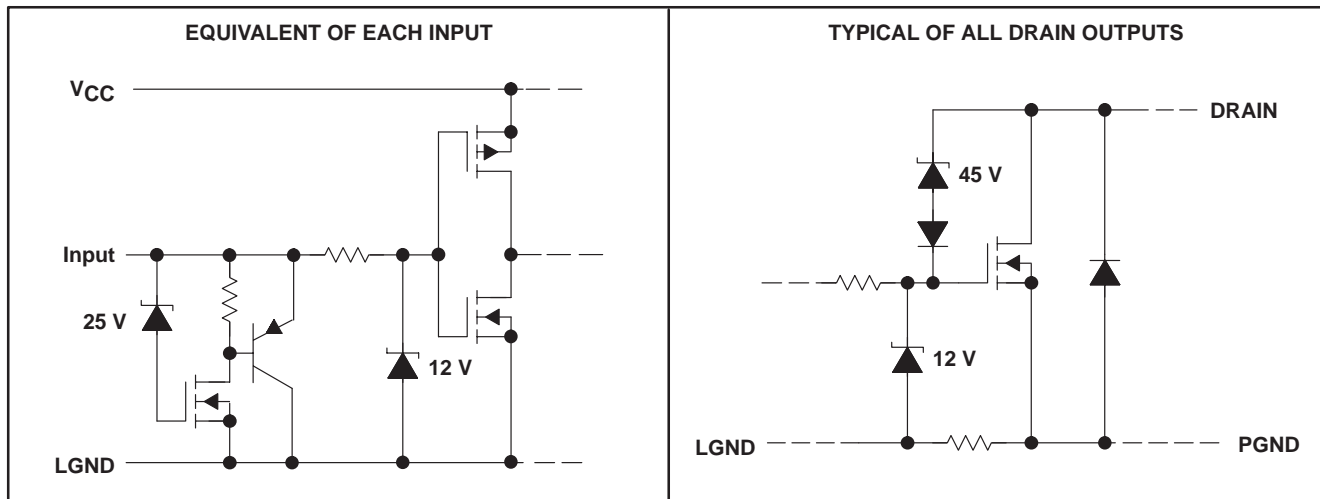

**absolute maximum ratings over recommended operating case temperature range (unless otherwise noted)†**

Logic supply voltage, $V_{CC}$ (see Note 1)	7 V
Logic input voltage range, $V_I$	-0.3 V to 7 V
Power DMOS drain-to-source voltage, $V_{DS}$ (see Note 2)	45 V
Continuous source-drain diode anode current	1 A
Pulsed source-drain diode anode current	2 A
Pulsed drain current, each output, all outputs on, $I_{Dn}$ , $T_A = 25^\circ\text{C}$ (see Note 3)	750 mA
Continuous drain current, each output, all outputs on, $I_{Dn}$ , $T_A = 25^\circ\text{C}$	250 mA
Peak drain current single output, $I_{DM}$ , $T_A = 25^\circ\text{C}$ (see Note 3)	2 A
Single-pulse avalanche energy, $E_{AS}$ (see Note 4)	75 mJ
Avalanche current, $I_{AS}$ (see Note 4)	1 A
Continuous total power dissipation	See Dissipation Rating Table
Operating virtual junction temperature range, $T_J$	-40°C to 150°C
Storage temperature range, $T_{stg}$	-65°C to 150°C
Lead temperature 1,6 mm (1/16 inch) from case for 10 seconds	260°C

† Stresses beyond those listed under “absolute maximum ratings” may cause permanent damage to the device. These are stress ratings only and functional operation of the device at these or any other conditions beyond those indicated under “recommended operating conditions” is not implied. Exposure to absolute-maximum-rated conditions for extended periods may affect device reliability.

- NOTES:
1. All voltage values are with respect to LGND and PGND.
  2. Each power DMOS source is internally connected to PGND.
  3. Pulse duration  $\leq 100 \mu\text{s}$ , duty cycle  $\leq 2\%$
  4. DRAIN supply voltage = 15 V, starting junction temperature ( $T_{JS}$ ) = 25°C, L = 100 mH,  $I_{AS} = 1 \text{ A}$  (see Figure 4).

**DISSIPATION RATING TABLE**

PACKAGE	$T_A \leq 25^\circ\text{C}$ POWER RATING	DERATING FACTOR ABOVE $T_A = 25^\circ\text{C}$	$T_A = 125^\circ\text{C}$ POWER RATING
DW	1125 mW	9.0 mW/°C	225 mW
N	1150 mW	9.2 mW/°C	230 mW

# TPIC6595

## POWER LOGIC 8-BIT SHIFT REGISTER

SLIS010B – APRIL 1992 – REVISED MAY 2005

recommended operating conditions over recommended operating temperature range (unless otherwise noted)

	MIN	MAX	UNIT
Logic supply voltage, $V_{CC}$	4.5	5.5	V
High-level input voltage, $V_{IH}$	0.85 $V_{CC}$		V
Low-level input voltage, $V_{IL}$		0.15 $V_{CC}$	V
Pulsed drain output current, $T_C = 25^\circ\text{C}$ , $V_{CC} = 5\text{ V}$ (see Notes 3 and 5)	-1.8	1.5	A
Setup time, SER IN high before SRCK $\uparrow$ , $t_{SU}$ (see Figure 2)	10		ns
Hold time, SER IN high after SRCK $\uparrow$ , $t_H$ (see Figure 2)	10		ns
Pulse duration, $t_W$ (see Figure 2)	20		ns
Operating case temperature, $T_C$	-40	125	$^\circ\text{C}$

electrical characteristics,  $V_{CC} = 5\text{ V}$ ,  $T_C = 25^\circ\text{C}$  (unless otherwise noted)

PARAMETER	TEST CONDITIONS	MIN	TYP	MAX	UNIT
$V_{(BR)DSX}$ Drain-source breakdown voltage	$I_D = 1\text{ mA}$	45			V
$V_{SD}$ Source-drain diode forward voltage	$I_F = 250\text{ mA}$ , See Note 3		0.85	1	V
$V_{OH}$ High-level output voltage, SER OUT	$I_{OH} = -20\text{ mA}$ , $V_{CC} = 4.5\text{ V}$	4.4	4.49		V
	$I_{OH} = -4\text{ mA}$ , $V_{CC} = 4.5\text{ V}$	4.1	4.3		
$V_{OL}$ Low-level output voltage, SER OUT	$I_{OH} = 20\text{ mA}$ , $V_{CC} = 4.5\text{ V}$		0.002	0.1	V
	$I_{OH} = 4\text{ mA}$ , $V_{CC} = 4.5\text{ V}$		0.2	0.4	
$V_{(hys)}$ Input hysteresis	$V_{DS} = 15\text{ V}$		1.3		V
$I_{IH}$ High-level input current	$V_{CC} = 5.5\text{ V}$ , $V_I = V_{CC}$			1	$\mu\text{A}$
$I_{IL}$ Low-level input current	$V_{CC} = 5.5\text{ V}$ , $V_I = 0$			-1	$\mu\text{A}$
$I_{CCL}$ Logic supply current	$I_O = 0$ , All inputs low		15	100	$\mu\text{A}$
$I_{CC}(\text{FRQ})$ Logic supply current frequency	$f_{SRCK} = 5\text{ MHz}$ , $I_O = 0$ , $C_L = 30\text{ pF}$ , See Figures 1, 2, and 6		0.6	5	mA
$I_N$ Nominal current	$V_{DS(\text{on})} = 0.5\text{ V}$ , $I_N = I_D$ , $T_C = 85^\circ\text{C}$		250		mA
$I_{DSX}$ Off-state drain current	$V_{DS} = 40\text{ V}$		0.05	1	$\mu\text{A}$
	$V_{DS} = 40\text{ V}$ , $T_C = 125^\circ\text{C}$		0.15	5	
$r_{DS(\text{on})}$ Static drain-source on-state resistance	$I_D = 250\text{ mA}$ , $V_{CC} = 4.5\text{ V}$		1.3	2	$\Omega$
	$I_D = 250\text{ mA}$ , $T_C = 125^\circ\text{C}$ , $V_{CC} = 4.5\text{ V}$		2	3.2	
	$I_D = 500\text{ mA}$ , $V_{CC} = 4.5\text{ V}$		1.3	2	

switching characteristics,  $V_{CC} = 5\text{ V}$ ,  $T_C = 25^\circ\text{C}$

PARAMETER	TEST CONDITIONS	MIN	TYP	MAX	UNIT	
$t_{PLH}$ Propagation delay time, low-to-high-level output from $\overline{G}$	$C_L = 30\text{ pF}$ , $I_D = 250\text{ mA}$ , See Figures 1 and 2		650		ns	
$t_{PHL}$ Propagation delay time, high-to-low-level output from $\overline{G}$			150		ns	
$t_r$ Rise time, drain output				750		ns
$t_f$ Fall time, drain output				425		ns
$t_a$ Reverse-recovery-current rise time	$I_F = 250\text{ mA}$ , $di/dt = 20\text{ A}/\mu\text{s}$ , See Notes 5 and 6 and Figure 3		100		ns	
$t_{rr}$ Reverse-recovery time			300			

- NOTES: 3. Pulse duration  $\leq 100\text{ }\mu\text{s}$ , duty cycle  $\leq 2\%$   
5. Technique should limit  $T_J - T_C$  to  $10^\circ\text{C}$  maximum.  
6. These parameters are measured with voltage-sensing contacts separate from the current-carrying contacts.  
7. Nominal current is defined for a consistent comparison between devices from different sources. It is the current that produces a voltage drop of  $0.5\text{ V}$  at  $T_C = 85^\circ\text{C}$ .



**thermal resistance**

PARAMETER		TEST CONDITIONS	MIN	MAX	UNIT
R <sub>θJA</sub>	Thermal resistance, junction-to-ambient	DW package		111	°C/W
		N package	All 8 outputs with equal power	108	

**PARAMETER MEASUREMENT INFORMATION**

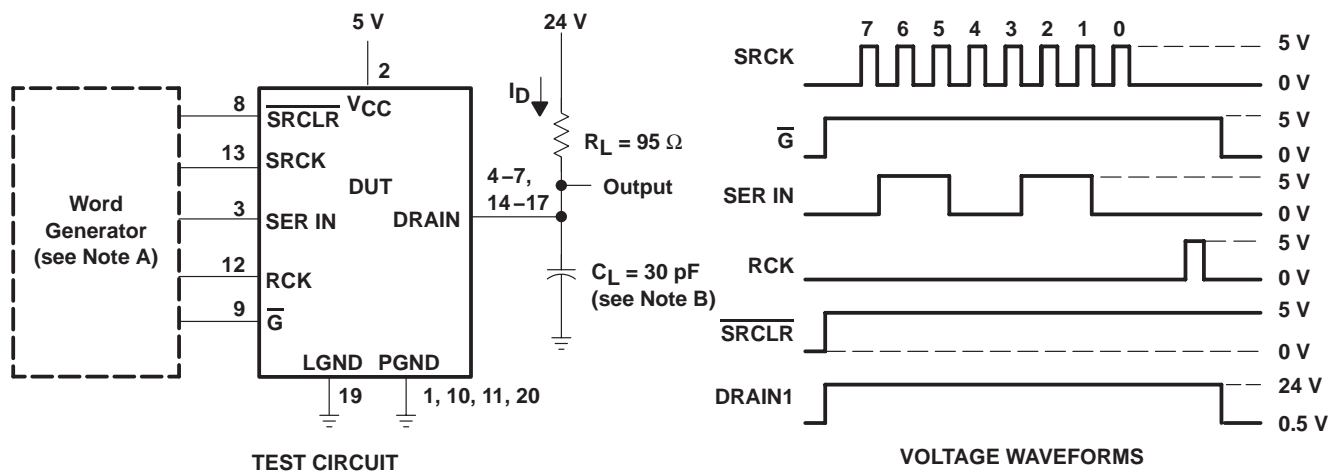

**Figure 1. Resistive Load Operation**

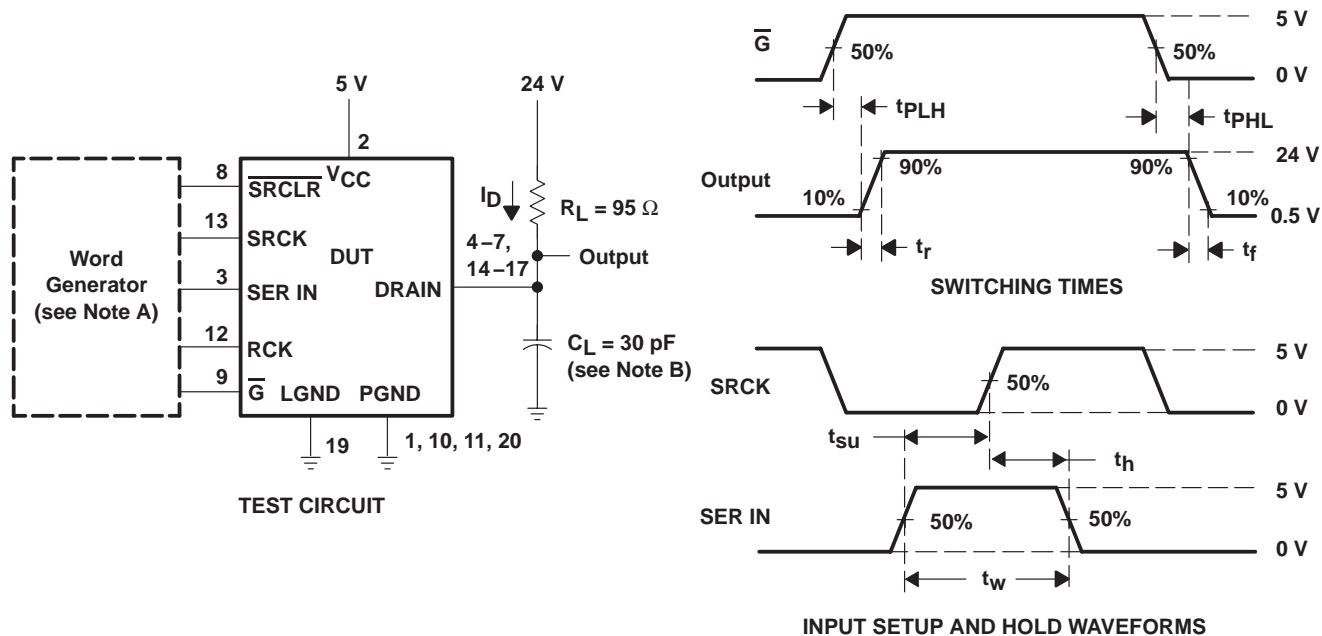

**Figure 2. Test Circuit, Switching Times, and Voltage Waveforms**

- NOTES: A. Outputs DRAIN 1, 2, 5, and 6 low (PGND), all other DRAIN outputs are at 24 V. The word generator has the following characteristics:  $t_r \leq 10$  ns,  $t_f \leq 10$  ns,  $t_w = 300$  ns, pulsed repetition rate (PRR) = 5 kHz,  $Z_O = 50 \Omega$ .  
B.  $C_L$  includes probe and jig capacitance.

# TPIC6595 POWER LOGIC 8-BIT SHIFT REGISTER

SLIS010B – APRIL 1992 – REVISED MAY 2005

## PARAMETER MEASUREMENT INFORMATION

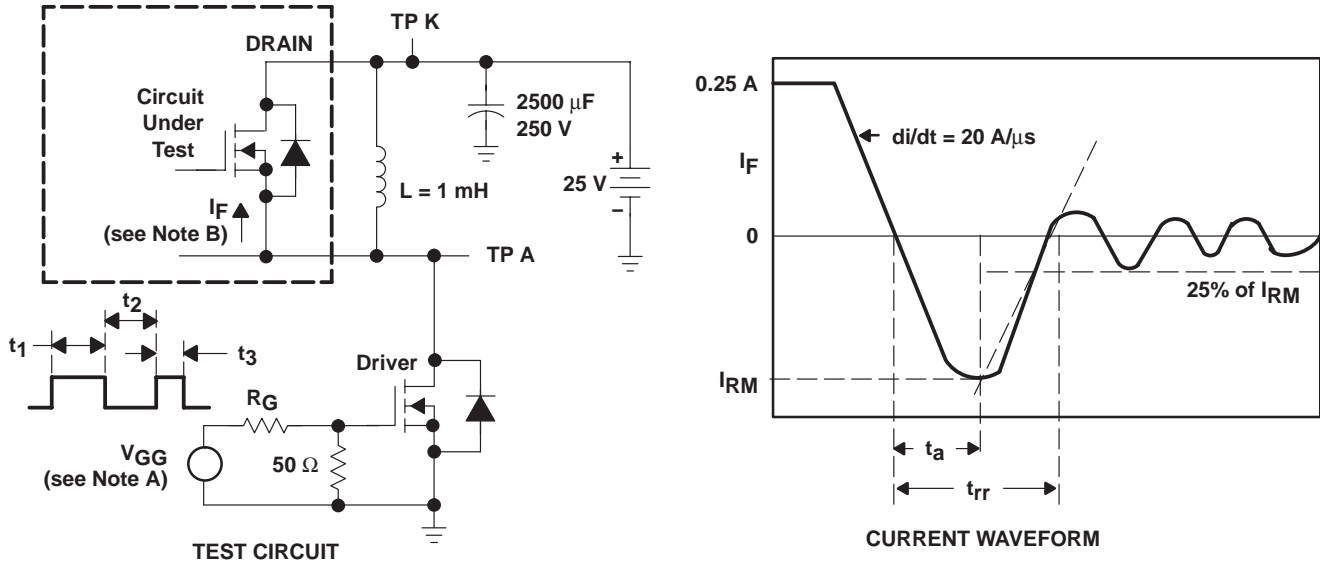

- NOTES: A. The  $V_{GG}$  amplitude and  $R_G$  are adjusted for  $di/dt = 20 \text{ A}/\mu\text{s}$ . A  $V_{GG}$  double-pulse train is used to set  $I_F = 0.25 \text{ A}$ , where  $t_1 = 10 \mu\text{s}$ ,  $t_2 = 7 \mu\text{s}$ , and  $t_3 = 3 \mu\text{s}$ .  
 B. The DRAIN terminal under test is connected to the TP K test point. All other terminals are connected together and connected to the TP A test point.

Figure 3. Reverse-Recovery-Current Test Circuit and Waveforms of Source-Drain Diode

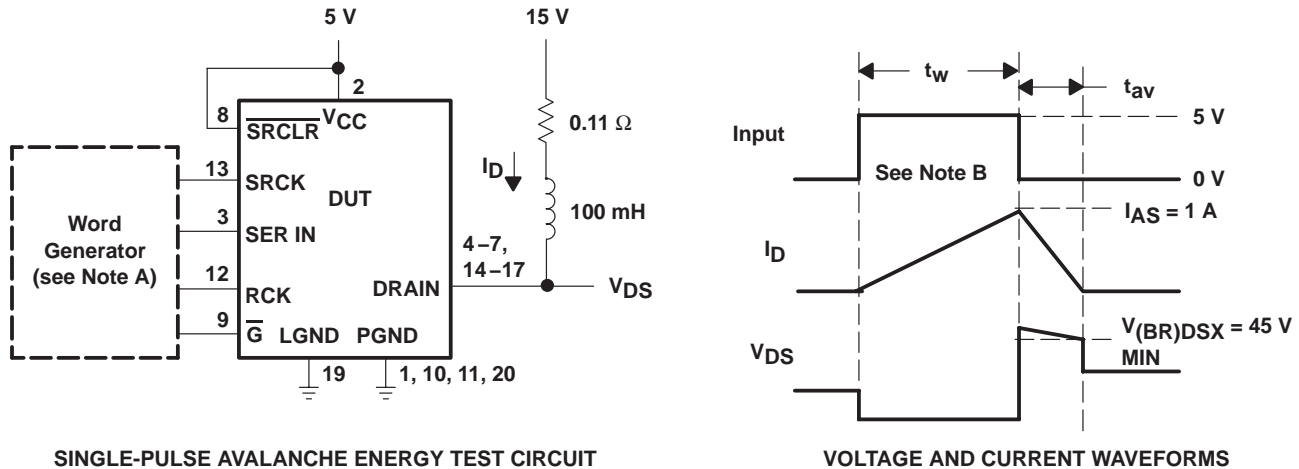

- NOTES: A. The word generator has the following characteristics:  $t_r \leq 10 \text{ ns}$ ,  $t_f \leq 10 \text{ ns}$ ,  $Z_O = 50 \Omega$ .  
 B. Input pulse duration,  $t_w$ , is increased until peak current  $I_{AS} = 1 \text{ A}$ .  
 Energy test level is defined as  $E_{AS} = I_{AS} \times V_{(BR)DSX} \times t_{av}/2 = 75 \text{ mJ}$ , where  $t_{av}$  = avalanche time.

Figure 4. Single-Pulse Avalanche Energy Test Circuit and Waveforms

TYPICAL CHARACTERISTICS

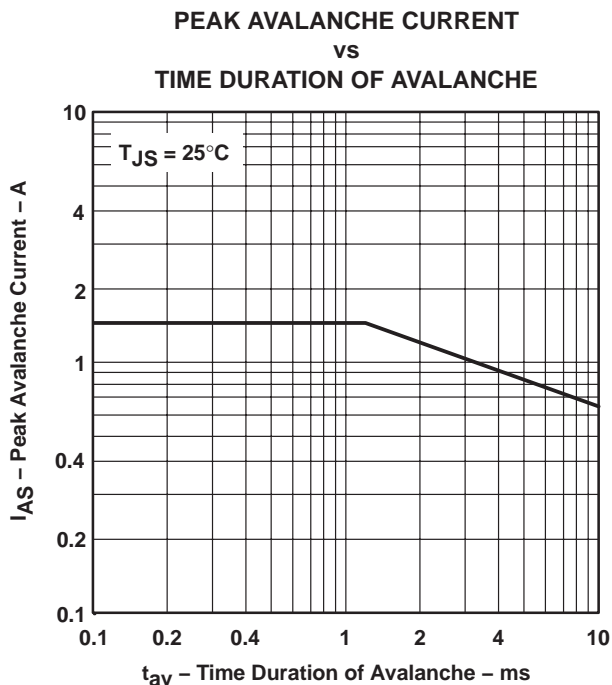

Figure 5

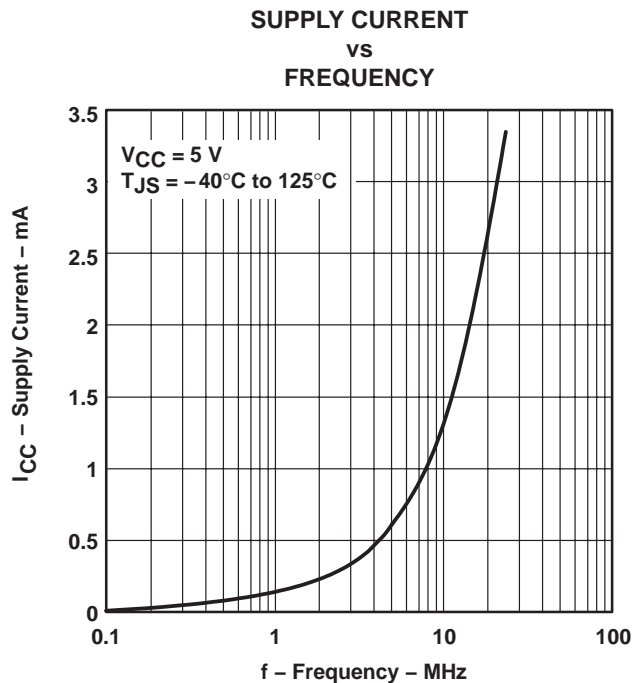

Figure 6

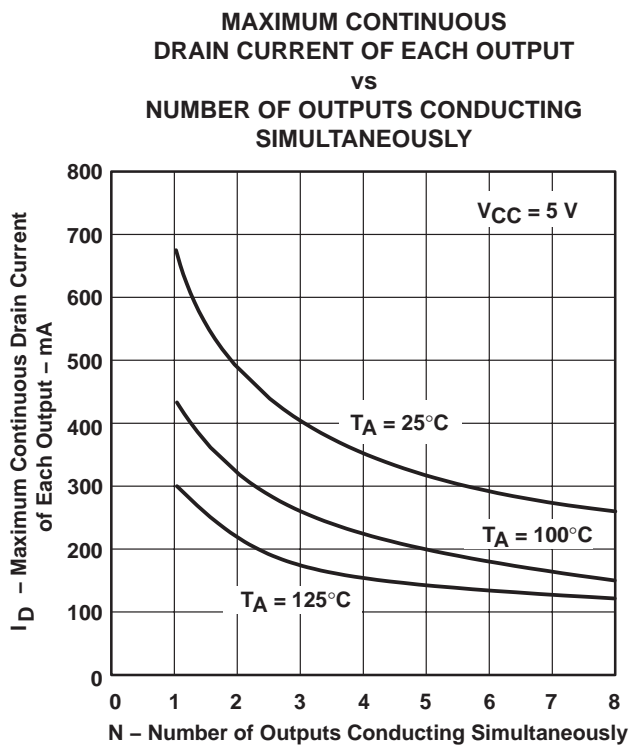

Figure 7

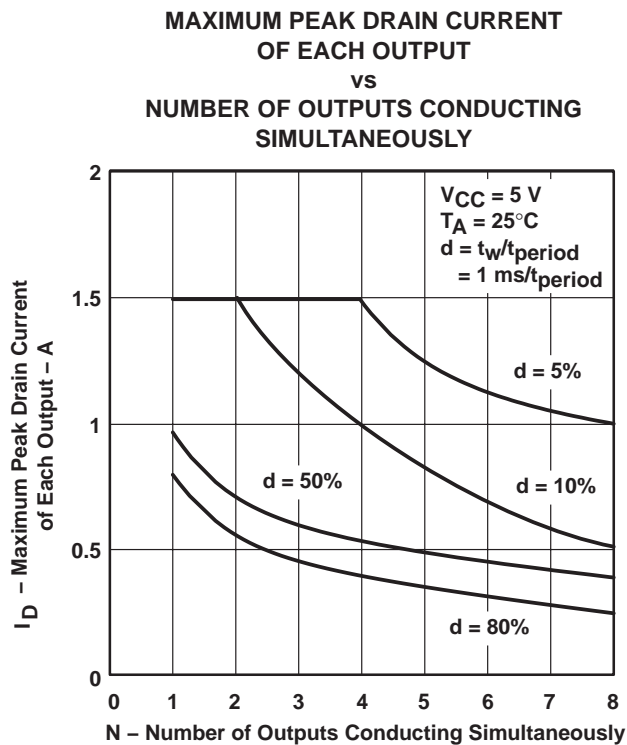

Figure 8

# TPIC6595 POWER LOGIC 8-BIT SHIFT REGISTER

SLIS010B – APRIL 1992 – REVISED MAY 2005

## TYPICAL CHARACTERISTICS

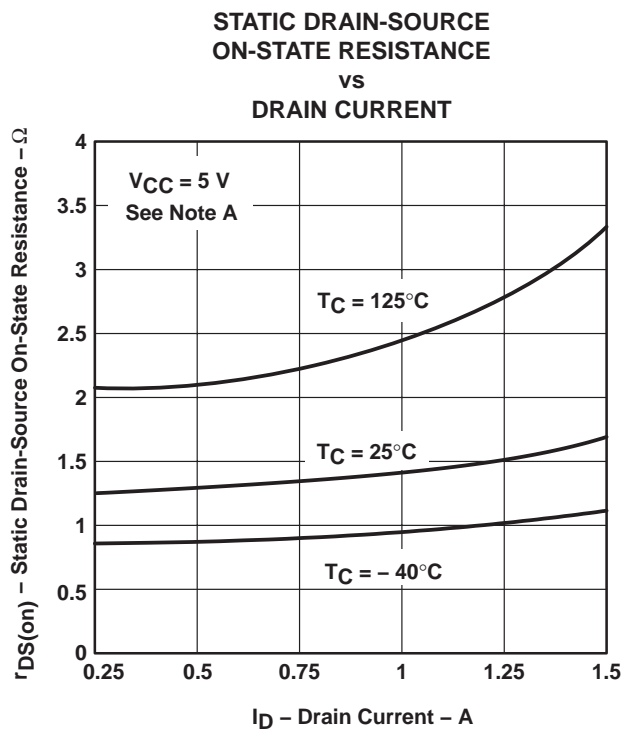

Figure 9

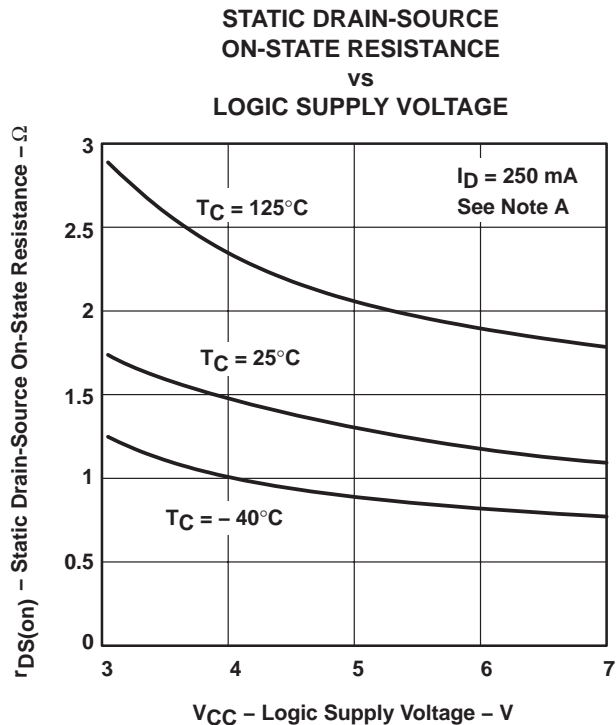

Figure 10

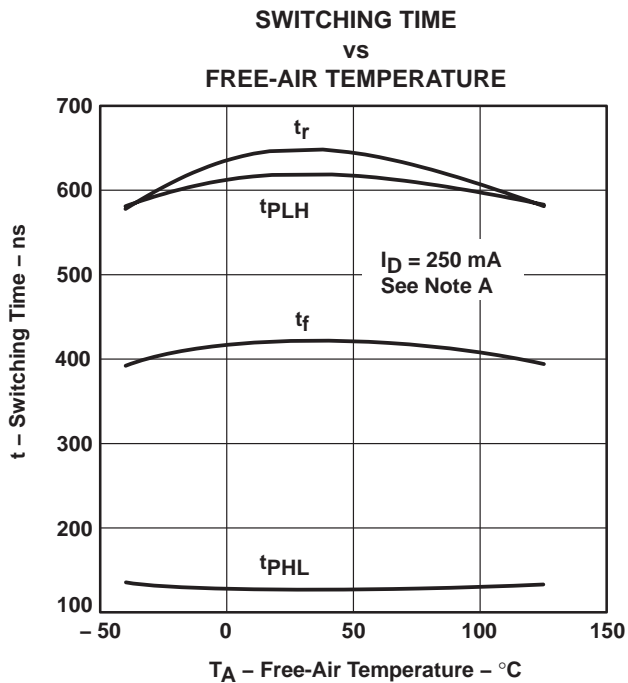

Figure 11

NOTE A: Technique should limit  $T_J - T_C$  to  $10^\circ\text{C}$  maximum.

---

**Revision History**

DATE	REV	PAGE	SECTION	DESCRIPTION
5/18/05	B	5	Figure 1	Changed <u>SRCLR</u> timing diagram
10/1/96	A		—	—
4/1992	*			Original reversion

NOTE: Page numbers for previous revisions may differ from page numbers in the current version.

**PACKAGING INFORMATION**

Orderable Device	Status <sup>(1)</sup>	Package Type	Package Drawing	Pins	Package Qty	Eco Plan <sup>(2)</sup>	Lead/Ball Finish	MSL Peak Temp <sup>(3)</sup>
TPIC6595DW	ACTIVE	SOIC	DW	20	25	TBD	CU NIPDAU	Level-1-220C-UNLIM
TPIC6595DWG4	ACTIVE	SOIC	DW	20	25	Green (RoHS & no Sb/Br)	CU NIPDAU	Level-1-260C-UNLIM
TPIC6595DWR	ACTIVE	SOIC	DW	20	2000	Green (RoHS & no Sb/Br)	CU NIPDAU	Level-1-260C-UNLIM
TPIC6595DWRG4	ACTIVE	SOIC	DW	20	2000	Green (RoHS & no Sb/Br)	CU NIPDAU	Level-1-260C-UNLIM
TPIC6595N	ACTIVE	PDIP	N	20	20	Pb-Free (RoHS)	CU NIPDAU	N / A for Pkg Type

<sup>(1)</sup> The marketing status values are defined as follows:

**ACTIVE:** Product device recommended for new designs.

**LIFEBUY:** TI has announced that the device will be discontinued, and a lifetime-buy period is in effect.

**NRND:** Not recommended for new designs. Device is in production to support existing customers, but TI does not recommend using this part in a new design.

**PREVIEW:** Device has been announced but is not in production. Samples may or may not be available.

**OBsolete:** TI has discontinued the production of the device.

<sup>(2)</sup> Eco Plan - The planned eco-friendly classification: Pb-Free (RoHS), Pb-Free (RoHS Exempt), or Green (RoHS & no Sb/Br) - please check <http://www.ti.com/productcontent> for the latest availability information and additional product content details.

**TBD:** The Pb-Free/Green conversion plan has not been defined.

**Pb-Free (RoHS):** TI's terms "Lead-Free" or "Pb-Free" mean semiconductor products that are compatible with the current RoHS requirements for all 6 substances, including the requirement that lead not exceed 0.1% by weight in homogeneous materials. Where designed to be soldered at high temperatures, TI Pb-Free products are suitable for use in specified lead-free processes.

**Pb-Free (RoHS Exempt):** This component has a RoHS exemption for either 1) lead-based flip-chip solder bumps used between the die and package, or 2) lead-based die adhesive used between the die and leadframe. The component is otherwise considered Pb-Free (RoHS compatible) as defined above.

**Green (RoHS & no Sb/Br):** TI defines "Green" to mean Pb-Free (RoHS compatible), and free of Bromine (Br) and Antimony (Sb) based flame retardants (Br or Sb do not exceed 0.1% by weight in homogeneous material)

<sup>(3)</sup> MSL, Peak Temp. -- The Moisture Sensitivity Level rating according to the JEDEC industry standard classifications, and peak solder temperature.

**Important Information and Disclaimer:**The information provided on this page represents TI's knowledge and belief as of the date that it is provided. TI bases its knowledge and belief on information provided by third parties, and makes no representation or warranty as to the accuracy of such information. Efforts are underway to better integrate information from third parties. TI has taken and continues to take reasonable steps to provide representative and accurate information but may not have conducted destructive testing or chemical analysis on incoming materials and chemicals. TI and TI suppliers consider certain information to be proprietary, and thus CAS numbers and other limited information may not be available for release.

In no event shall TI's liability arising out of such information exceed the total purchase price of the TI part(s) at issue in this document sold by TI to Customer on an annual basis.

## TAPE AND REEL INFORMATION

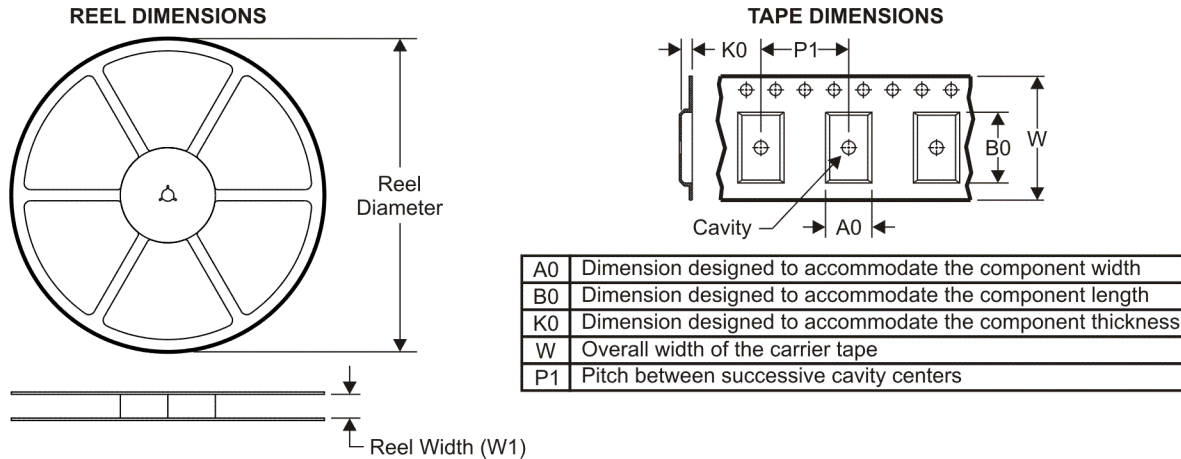

### QUADRANT ASSIGNMENTS FOR PIN 1 ORIENTATION IN TAPE



\*All dimensions are nominal

Device	Package Type	Package Drawing	Pins	SPQ	Reel Diameter (mm)	Reel Width W1 (mm)	A0 (mm)	B0 (mm)	K0 (mm)	P1 (mm)	W (mm)	Pin1 Quadrant
TPIC6595DWR	SOIC	DW	20	2000	330.0	24.4	10.8	13.1	2.65	12.0	24.0	Q1

**TAPE AND REEL BOX DIMENSIONS**



\*All dimensions are nominal

Device	Package Type	Package Drawing	Pins	SPQ	Length (mm)	Width (mm)	Height (mm)
TPIC6595DWR	SOIC	DW	20	2000	346.0	346.0	41.0

N (R-PDIP-T\*\*)

PLASTIC DUAL-IN-LINE PACKAGE

16 PINS SHOWN



- NOTES:
- A. All linear dimensions are in inches (millimeters).
  - B. This drawing is subject to change without notice.
  - Falls within JEDEC MS-001, except 18 and 20 pin minimum body length (Dim A).
  - The 20 pin end lead shoulder width is a vendor option, either half or full width.



DW (R-PDSO-G20)

PLASTIC SMALL OUTLINE

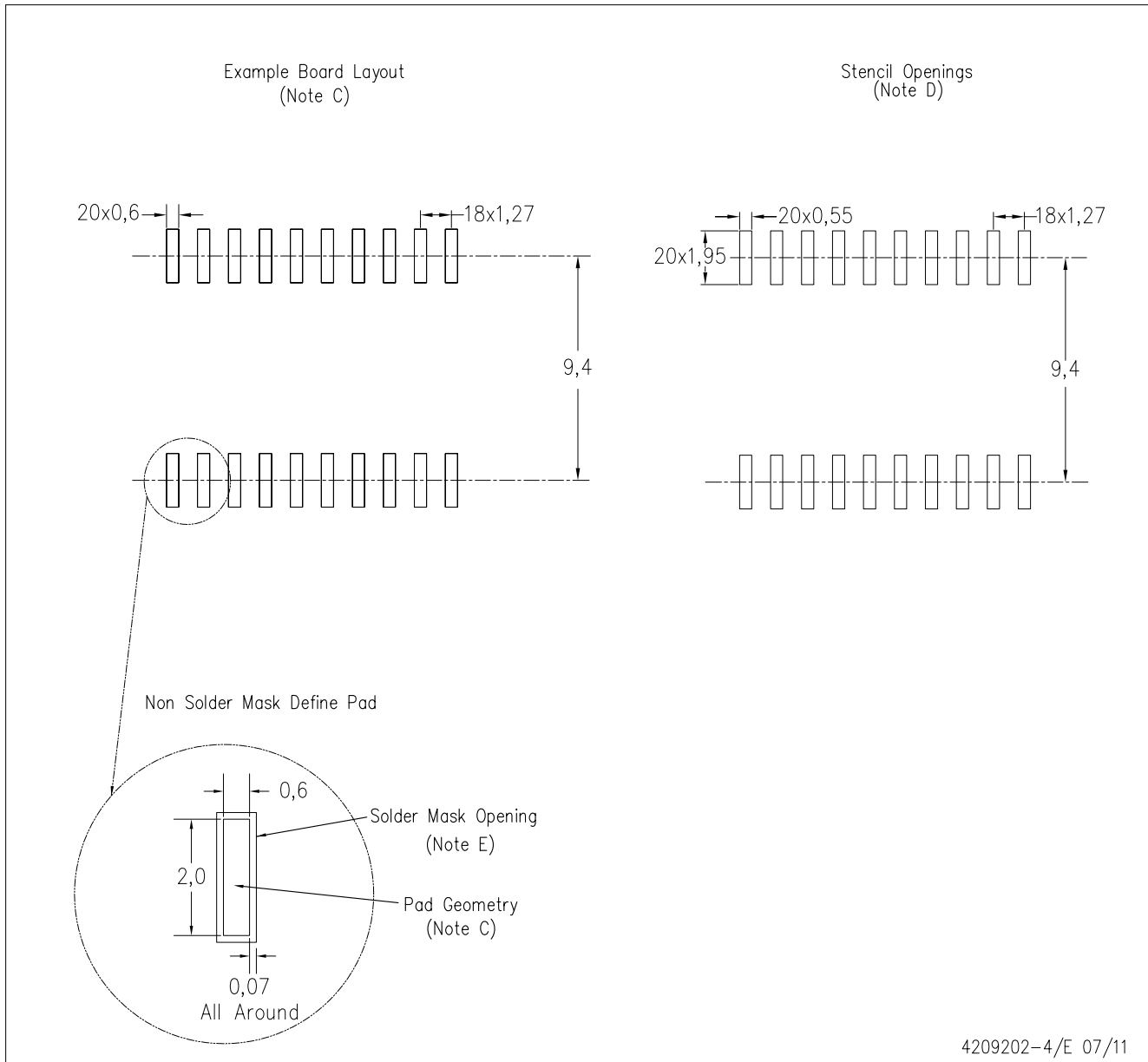

4209202-4/E 07/11

- NOTES:
- A. All linear dimensions are in millimeters.
  - B. This drawing is subject to change without notice.
  - C. Refer to IPC7351 for alternate board design.
  - D. Laser cutting apertures with trapezoidal walls and also rounding corners will offer better paste release. Customers should contact their board assembly site for stencil design recommendations. Refer to IPC-7525
  - E. Customers should contact their board fabrication site for solder mask tolerances between and around signal pads.

## IMPORTANT NOTICE

Texas Instruments Incorporated and its subsidiaries (TI) reserve the right to make corrections, modifications, enhancements, improvements, and other changes to its products and services at any time and to discontinue any product or service without notice. Customers should obtain the latest relevant information before placing orders and should verify that such information is current and complete. All products are sold subject to TI's terms and conditions of sale supplied at the time of order acknowledgment.

TI warrants performance of its hardware products to the specifications applicable at the time of sale in accordance with TI's standard warranty. Testing and other quality control techniques are used to the extent TI deems necessary to support this warranty. Except where mandated by government requirements, testing of all parameters of each product is not necessarily performed.

TI assumes no liability for applications assistance or customer product design. Customers are responsible for their products and applications using TI components. To minimize the risks associated with customer products and applications, customers should provide adequate design and operating safeguards.

TI does not warrant or represent that any license, either express or implied, is granted under any TI patent right, copyright, mask work right, or other TI intellectual property right relating to any combination, machine, or process in which TI products or services are used. Information published by TI regarding third-party products or services does not constitute a license from TI to use such products or services or a warranty or endorsement thereof. Use of such information may require a license from a third party under the patents or other intellectual property of the third party, or a license from TI under the patents or other intellectual property of TI.

Reproduction of TI information in TI data books or data sheets is permissible only if reproduction is without alteration and is accompanied by all associated warranties, conditions, limitations, and notices. Reproduction of this information with alteration is an unfair and deceptive business practice. TI is not responsible or liable for such altered documentation. Information of third parties may be subject to additional restrictions.

Resale of TI products or services with statements different from or beyond the parameters stated by TI for that product or service voids all express and any implied warranties for the associated TI product or service and is an unfair and deceptive business practice. TI is not responsible or liable for any such statements.

TI products are not authorized for use in safety-critical applications (such as life support) where a failure of the TI product would reasonably be expected to cause severe personal injury or death, unless officers of the parties have executed an agreement specifically governing such use. Buyers represent that they have all necessary expertise in the safety and regulatory ramifications of their applications, and acknowledge and agree that they are solely responsible for all legal, regulatory and safety-related requirements concerning their products and any use of TI products in such safety-critical applications, notwithstanding any applications-related information or support that may be provided by TI. Further, Buyers must fully indemnify TI and its representatives against any damages arising out of the use of TI products in such safety-critical applications.

TI products are neither designed nor intended for use in military/aerospace applications or environments unless the TI products are specifically designated by TI as military-grade or "enhanced plastic." Only products designated by TI as military-grade meet military specifications. Buyers acknowledge and agree that any such use of TI products which TI has not designated as military-grade is solely at the Buyer's risk, and that they are solely responsible for compliance with all legal and regulatory requirements in connection with such use.

TI products are neither designed nor intended for use in automotive applications or environments unless the specific TI products are designated by TI as compliant with ISO/TS 16949 requirements. Buyers acknowledge and agree that, if they use any non-designated products in automotive applications, TI will not be responsible for any failure to meet such requirements.

Following are URLs where you can obtain information on other Texas Instruments products and application solutions:

### Products

Audio	<a href="http://www.ti.com/audio">www.ti.com/audio</a>
Amplifiers	<a href="http://amplifier.ti.com">amplifier.ti.com</a>
Data Converters	<a href="http://dataconverter.ti.com">dataconverter.ti.com</a>
DLP® Products	<a href="http://www.dlp.com">www.dlp.com</a>
DSP	<a href="http://dsp.ti.com">dsp.ti.com</a>
Clocks and Timers	<a href="http://www.ti.com/clocks">www.ti.com/clocks</a>
Interface	<a href="http://interface.ti.com">interface.ti.com</a>
Logic	<a href="http://logic.ti.com">logic.ti.com</a>
Power Mgmt	<a href="http://power.ti.com">power.ti.com</a>
Microcontrollers	<a href="http://microcontroller.ti.com">microcontroller.ti.com</a>
RFID	<a href="http://www.ti-rfid.com">www.ti-rfid.com</a>
RF/IF and ZigBee® Solutions	<a href="http://www.ti.com/lprf">www.ti.com/lprf</a>

### Applications

Communications and Telecom	<a href="http://www.ti.com/communications">www.ti.com/communications</a>
Computers and Peripherals	<a href="http://www.ti.com/computers">www.ti.com/computers</a>
Consumer Electronics	<a href="http://www.ti.com/consumer-apps">www.ti.com/consumer-apps</a>
Energy and Lighting	<a href="http://www.ti.com/energy">www.ti.com/energy</a>
Industrial	<a href="http://www.ti.com/industrial">www.ti.com/industrial</a>
Medical	<a href="http://www.ti.com/medical">www.ti.com/medical</a>
Security	<a href="http://www.ti.com/security">www.ti.com/security</a>
Space, Avionics and Defense	<a href="http://www.ti.com/space-avionics-defense">www.ti.com/space-avionics-defense</a>
Transportation and Automotive	<a href="http://www.ti.com/automotive">www.ti.com/automotive</a>
Video and Imaging	<a href="http://www.ti.com/video">www.ti.com/video</a>
Wireless	<a href="http://www.ti.com/wireless-apps">www.ti.com/wireless-apps</a>

TI E2E Community Home Page

[e2e.ti.com](http://e2e.ti.com)

Mailing Address: Texas Instruments, Post Office Box 655303, Dallas, Texas 75265  
Copyright © 2011, Texas Instruments Incorporated