

7-CHANNEL INTEGRATED ESD SOLUTION FOR VGA PORT WITH INTEGRATED LEVEL SHIFTER AND MATCHING IMPEDANCE

Check for Samples: [TPD7S019](#)

FEATURES

- 7-Channel ESD Protection Includes ESD Protection, Level-Shifting, Buffering and Sync Impedance Matching
- Exceeds IEC61000-4-2 (Level 4) ESD Protection to Requirements on the External Pins
 - ± 15 -kV Human-Body Model (HBM)
 - ± 8 -kV IEC 61000-4-2 Contact Discharge
- Very Low Loading Capacitance from ESD Protection Diodes on VIDEO Lines (2.5 pF)
- 5-V Drivers for HSYNC and VSYNC Lines
- Integrated Impedance Matching Resistors on Sync Lines:
 - TPD7S019-65: 65- Ω Termination
 - TPD7S019-15: 15- Ω Termination
 - TPD7S019-55: 55- Ω Termination

- Bi-Directional Level Shifting N-Channel FETs Provided for DDC_CLK and DDC_DATA Channels
- Flow-Through Single-In-Line Pin Mapping Ensures no Additional Board Layout Burden while Placing the ESD Protection Chip Near the Connector

APPLICATIONS

- VGA and DVI-I Ports in:
 - Desktop and Notebook PCs
 - Graphics Cards
 - Set Top Boxes
 - TV

**RSV PACKAGE
(TOP VIEW)**

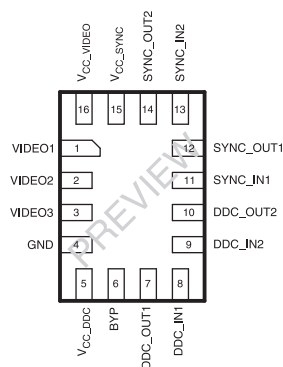

**DBQ PACKAGE
(TOP VIEW)**

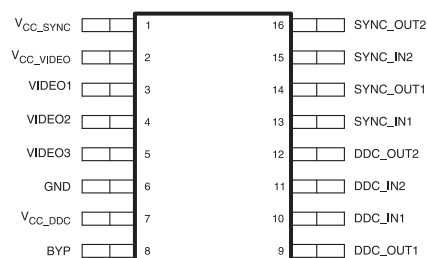

ORDERING INFORMATION

T_A	PACKAGE ⁽¹⁾ ⁽²⁾		ORDERABLE PART NUMBER	TOP-SIDE MARKING
–40°C to 85°C	μ QFN – RSV	Tape and reel	TPD7S019-15RSVR	PREVIEW
		Tape and reel	TPD7S019-15DBQR	PQ19-15
	SSOP/QSOP – DBQ	Tape and reel	TPD7S019-55DBQR	PQ19-55
		Tape and reel	TPD7S019-65DBQR	PQ19-65

(1) Package drawings, thermal data, and symbolization are available at www.ti.com/packaging.

(2) For the most current package and ordering information, see the Package Option Addendum at the end of this document, or see the TI website at www.ti.com.



Please be aware that an important notice concerning availability, standard warranty, and use in critical applications of Texas Instruments semiconductor products and disclaimers thereto appears at the end of this data sheet.

TERMINATION AT SYNC	PITCH	LENGTH (TYP)	WIDTH (TYP)	HEIGHT (MAX)	ORDERABLE PART NO.
15-Ω	0.635 mm	4.9 mm	6.0 mm	1.75 mm	TPD7S019-15DBQR
55-Ω					TPD7S019-55DBQR
65-Ω					TPD7S019-65DBQR
15-Ω	0.4 mm	2.6 mm	1.8 mm	0.55 mm	TPD7S019-15RSVR

DESCRIPTION/ORDERING INFORMATION

The TPD7S019 is an integrated 7-channel ESD solution for the VGA or DVI-I port connector. This device integrates ESD protection for all signals, level shifting for the DDC signals and buffering for the SYNC signals.

Three individual supply lines control the power rails of the VIDEO, DDC and SYNC channels to facilitate interfacing with low voltage video controller ICs in mixed supply-voltage environments.

Two non-inverting drivers provide buffering for the HSYNC and VSYNC signals from the video controller IC (SYNC1, SYNC2). These buffers accept TTL input levels and convert them to CMOS output levels that swing between Ground and VCC_SYNC, which is typically 5 V. Additionally, each driver has a series termination resistor (RT) connected to the SYNC_OUT pin, eliminating the external termination resistors typically required for the HSYNC and VSYNC lines of the video cable. At the SYNC output the TPD7S019 offers 65-Ω, 55-Ω, or 15-Ω series termination resistor option to match different transmission line impedances.

Two N-channel MOSFETs provide the level shifting function required when the DDC controller is operated at a lower supply voltage than the monitor. The gate terminals for the MOSFETs (VCC_DDC) should be connected to the supply rail (typically 3.3 V) that supplies power to the transceivers of the DDC controller.

The TPD7S019 confirms the IEC61000-4-2 (Level 4) system level ESD protection and ±15KV HBM ESD protection. This device is offered in space-saving 16-pin DBQ and 16-pin RSV packages.

The TPD7S019 is characterized for operation over ambient air temperature of –40°C to 85°C.

CIRCUIT DIAGRAM

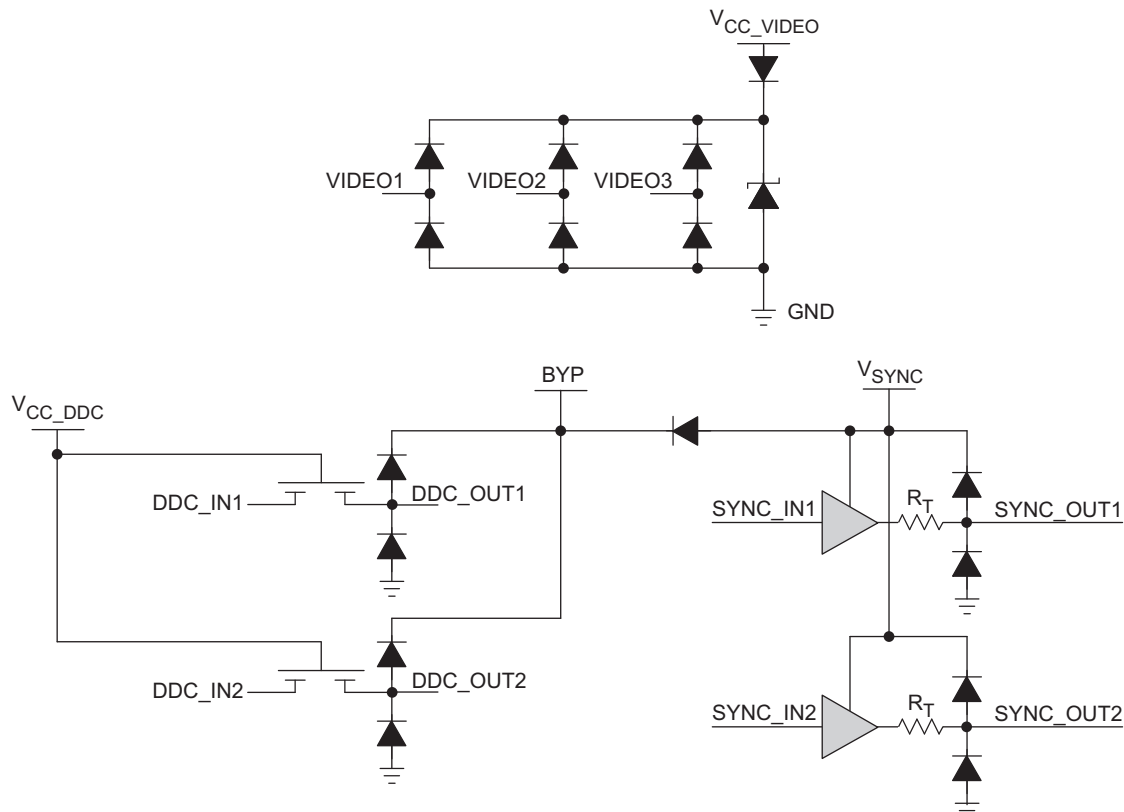

TERMINAL FUNCTIONS

TERMINAL			TYPE	DESCRIPTION
NAME	NO.			
	DBQ	RSV		
BYP	8	6	Power	Bypass pin. Using a 0.2 μ F bypass capacitor will increase the ESD robustness of the system.
DDC_IN1 DDC_IN2	10 11	8 9	I	DDC signal input. Connects to the VGA controller side of one of the sync lines.
DDC_OUT1 DDC_OUT2	9 12	7 10	O	DDC signal output. Connects to the video connector side of one of the sync lines.
GND	6	4	–	Ground
SYNC_IN1 SYNC_IN2	13 15	11 13	I	Sync signal buffer input. Connects to the VGA controller side of one of the sync lines.
SYNC_OUT1 SYNC_OUT2	14 16	12 14	O	Sync signal buffer output. Connects to the video connector side of one of the sync lines
VCC_DDC	7	5	Power	Isolated supply input for the DDC_1 and DDC_2 level-shifting N-FET gates
VCC_SYNC	1	15	Power	Isolated supply input for the SYNC_1 and SYNC_2 level shifters and their associated ESD protection circuits
VCC_VIDEO	2	16	Power	Supply pin specifically for the VIDEO_1, VIDEO_2 and VIDEO_3 ESD protection circuits
VIDEO1 VIDEO2 VIDEO3	3 4 5	1 2 3	ESD	High-speed ESD clamp input

ABSOLUTE MAXIMUM RATINGS⁽¹⁾

over operating free-air temperature range (unless otherwise noted)

			MIN	MAX	UNIT
V_{CC_VIDEO} , V_{CC_DDC} , V_{CC_SYNC}	Supply voltage		–0.5	6.0	V
$V_{IO(VIDEO)}$	IO voltage	VIDEOx pins	–0.5	V_{CC_VIDEO}	V
$V_{I(SYNC)}$	Input voltage	SYNC pins	–0.5	V_{CC_SYNC}	V
$V_{I(DDC)}$	Input voltage	DDC_INx pins	–0.5	6.0	V
$V_{O(DDC)}$	Output voltage	DDC_INx pins	–0.5	6.0	V
T_{stg}	Storage temperature		–55	125	°C
	IEC 61000-4-2 Contact Discharge	VIDEO, DDC_OUT, SYNC_OUT pins		± 8	kV
	HBM ESD	VIDEO, DDC_OUT, SYNC_OUT pins		± 15	kV
		VCC, DDC_IN, SYNC_IN, BYP Pins		± 2	

(1) Stresses beyond those listed under "absolute maximum ratings" may cause permanent damage to the device. These are stress ratings only, and functional operation of the device at these or any other conditions beyond those indicated under "recommended operating conditions" is not implied. Exposure to absolute-maximum-rated conditions for extended periods may affect device reliability.

RECOMMENDED OPERATING CONDITIONS

over operating free-air temperature range (unless otherwise noted)

			MIN	MAX	UNIT
V_{CC_VIDEO} , V_{CC_DDC} , V_{CC_SYNC}	Supply voltage		0	5.5	V
$V_{IO(VIDEO)}$	IO voltage	VIDEOx pins	0	V_{CC_VIDEO}	V
$V_{I(SYNC)}$	Input voltage	SYNC pins	0	V_{CC_SYNC}	V
$V_{I(DDC)}$	Input voltage	DDC_INx pins	0	5.5	V
$V_{O(DDC)}$	Output voltage	DDC_INx Pins	0	5.5	V
T_A	Operating temperature		–40	85	°C

ELECTRICAL CHARACTERISTICS

over operating free-air temperature range (unless otherwise noted)

PARAMETER		TEST CONDITION	MIN	TYP	MAX	UNIT	
I_{CC_VIDEO}	V_{CC_VIDEO} supply current	$V_{CC_VIDEO} = 5\text{ V}$, VIDEO inputs at V_{CC_VIDEO} or GND		1	10	μA	
I_{CC_DDC}	V_{CC_DDC} supply current	$V_{CC_DDC} = 5\text{ V}$		1	10	μA	
I_{CC_SYNC}	V_{CC_SYNC} supply current	$V_{CC_SYNC} = 5\text{ V}$, SYNC inputs at GND or V_{CC_SYNC} , SYNC outputs unloaded		1	50	μA	
		SYNC inputs at 3 V; SYNC outputs unloaded			2.0	mA	
I_{IO_VIDEO}	VIDEO input/output pins	$V_{IO_VIDEO} = 3\text{ V}$		0.01	1.0	μA	
I_{OFF}	DDC pin power down leakage current	$V_{CC_DDC} \leq 0.4\text{ V}$, $V_{DDC_OUT} = 5\text{ V}$		0.01	1.0	μA	
V_D	Diode forward voltage for lower clamp of VIDEO, DDC, SYNC output pins	$I_D = 8\text{ mA}$, lower clamp diode	-0.6	-0.8	-0.95	V	
R_{DYN_VIDEO}	Dynamic resistance (VIDEO pins)	$I = 1\text{ A}$		1.0		Ω	
V_{IH}	High-level SYNC logic input voltage	$V_{CC_SYNC} = 5\text{ V}$	2.0			V	
V_{IL}	Low-level SYNC logic input voltage	$V_{CC_SYNC} = 5\text{ V}$			0.6	V	
V_{OH}	High-level SYNC logic output voltage	$I_{OH} = 0\text{ mA}$, $V_{CC_SYNC} = 5\text{ V}$	4.85			V	
V_{OH-15}	High-level SYNC logic output voltage	TPD7S019-15 $I_{OH} = 24\text{ mA}$, $V_{CC_SYNC} = 5\text{ V}$	2			V	
V_{OL}	Low-level SYNC logic output voltage	$I_{OH} = 0\text{ mA}$, $V_{CC_SYNC} = 5\text{ V}$			0.15	V	
V_{OL-15}	Low-level SYNC logic output voltage	TPD7S019-15			0.8	V	
		TPD7S019-55					
		TPD7S019-65					
R_T	SYNC driver output resistance	TPD7S019-15	$V_{CC_SYNC} = 5\text{ V}$, SYNC inputs at GND or 3 V			15	Ω
		TPD7S019-55				55	
		TPD7S019-65				65	
C_{IO_VIDEO}	IO capacitance of VIDEO pins	$V_{IO} = 2.5\text{ V}$		2.5	4	pF	
t_{PLH}	SYNC driver L => H propagation delay	$C_L = 50\text{ pF}$; $V_{CC} = 5\text{ V}$, input t_R and $t_F \leq 5\text{ ns}$			12	ns	
t_{PHL}	SYNC driver H => L propagation delay	$C_L = 50\text{ pF}$; $V_{CC} = 5\text{ V}$, input t_R and $t_F \leq 5\text{ ns}$			12	ns	
t_R, t_F	SYNC driver output rise & fall times	$C_L = 50\text{ pF}$; $V_{CC} = 5\text{ V}$, input t_R and $t_F \leq 5\text{ ns}$		4		ns	
V_{BR}	VIDEO ESD diode break-down voltage	$I_{IO} = 1\text{ mA}$	9			V	

Typical Characteristics

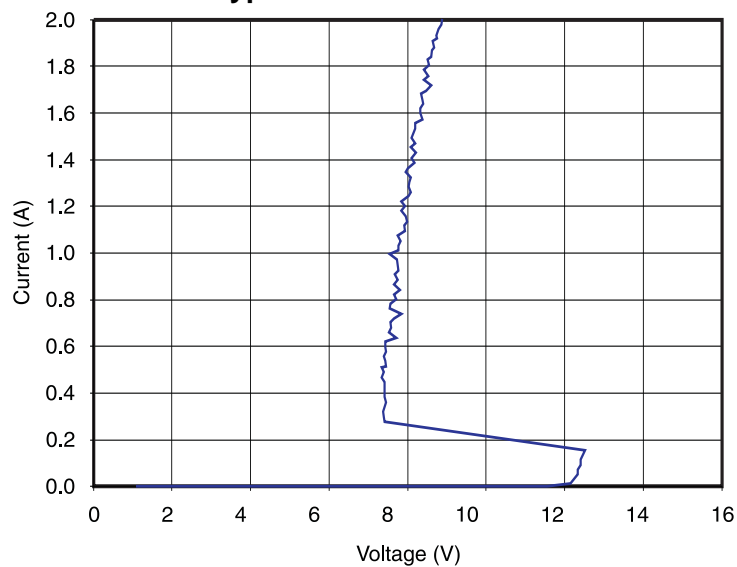

Figure 1. TPD7S019-xx TLP VID1 to GND, Barth, $T_{rr} = 10\text{ ns}$

Typical Characteristics (continued)

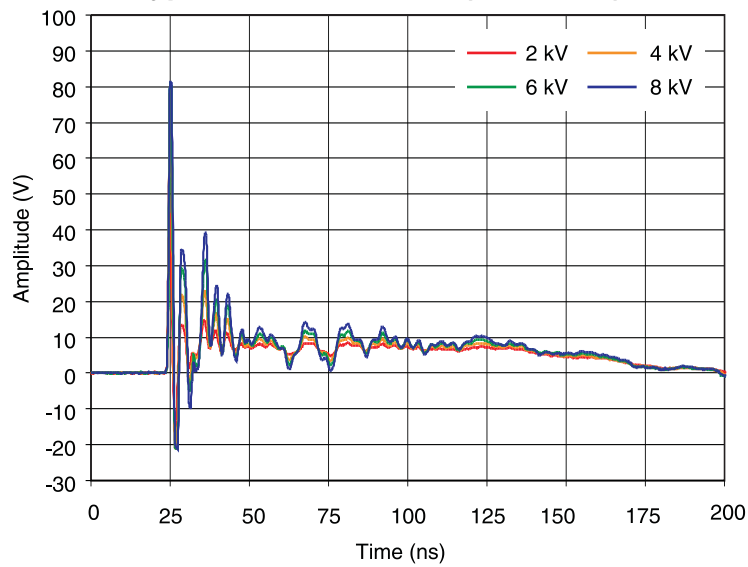

Figure 2. TPD7S019-xx IEC Clamping Waveforms Positive Contact

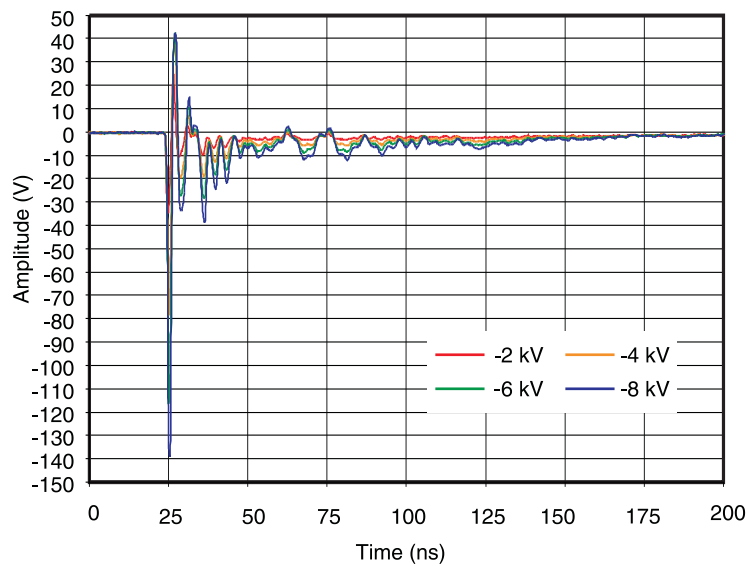

Figure 3. TPD7S019-xx IEC Clamping Waveforms Negative Contact

Typical Characteristics (continued)

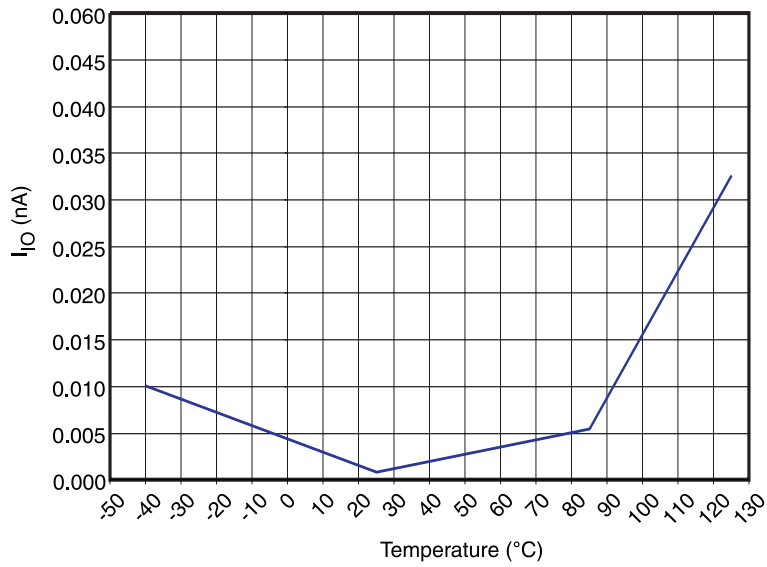

Figure 4. Leakage Current Trough VIDEO Pins
 $V_{CC_VIDEO} = 5\text{ V}$

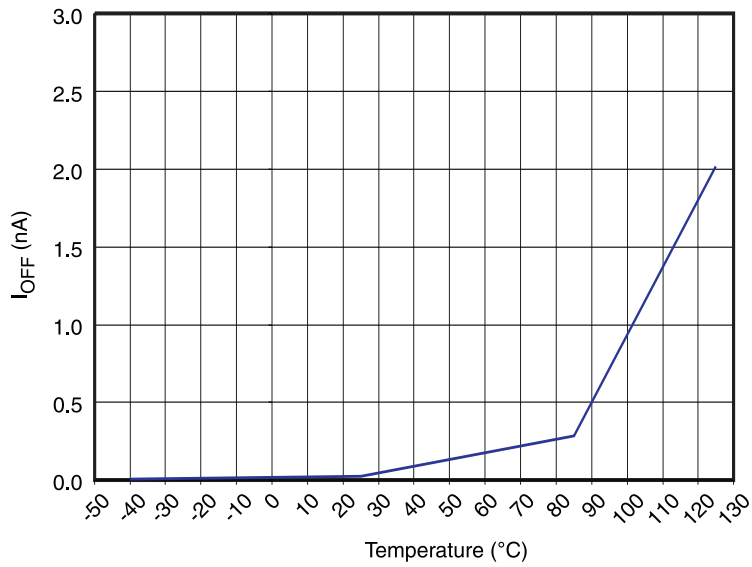

Figure 5. I_{OFF} (DDC_OUTx)
 $V_{CC_DDC} = 0\text{ V}$

APPLICATION INFORMATION

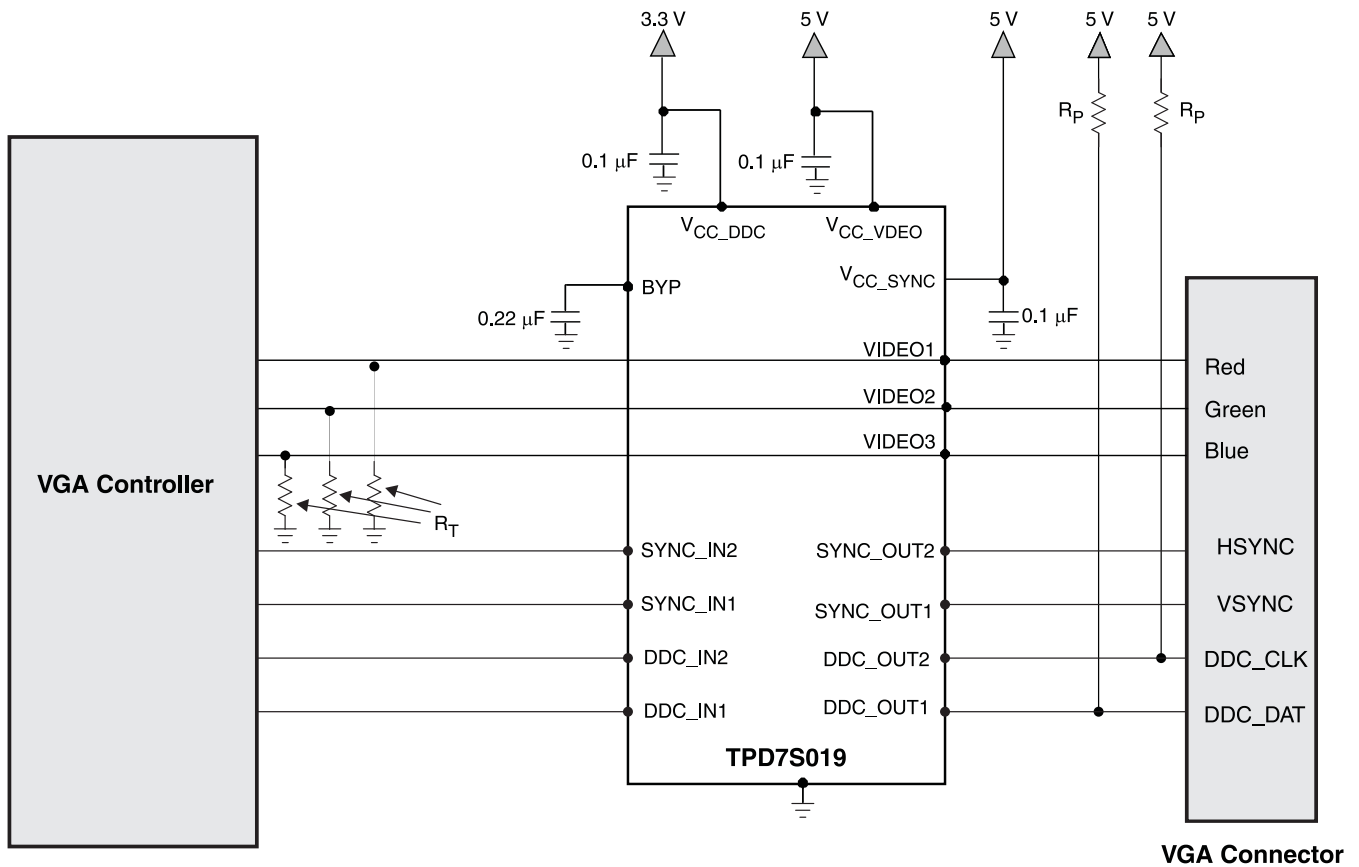

Figure 6. Typical Application Schematics with TPD7S019

R_p : Pullup resistor for the DDC data and clock lines. Typically system designer selects 47 k Ω pullup values

R_T : Line termination resistor for the RGB lines. R_T is selected to match the transmission line. For a single-ended transmission line, R_T can be anywhere from 50 Ω to 75 Ω depending on board trace impedance.

Some systems may require additional filters at the SYNC and RGB lines.

The TPD7S019 should be placed as close to the VGA port as possible.

The ESD protection channels VIDEO1, VIDEO2, VIDEO3 are identical circuits, they can be used interchangeably between the R, G, B signals.

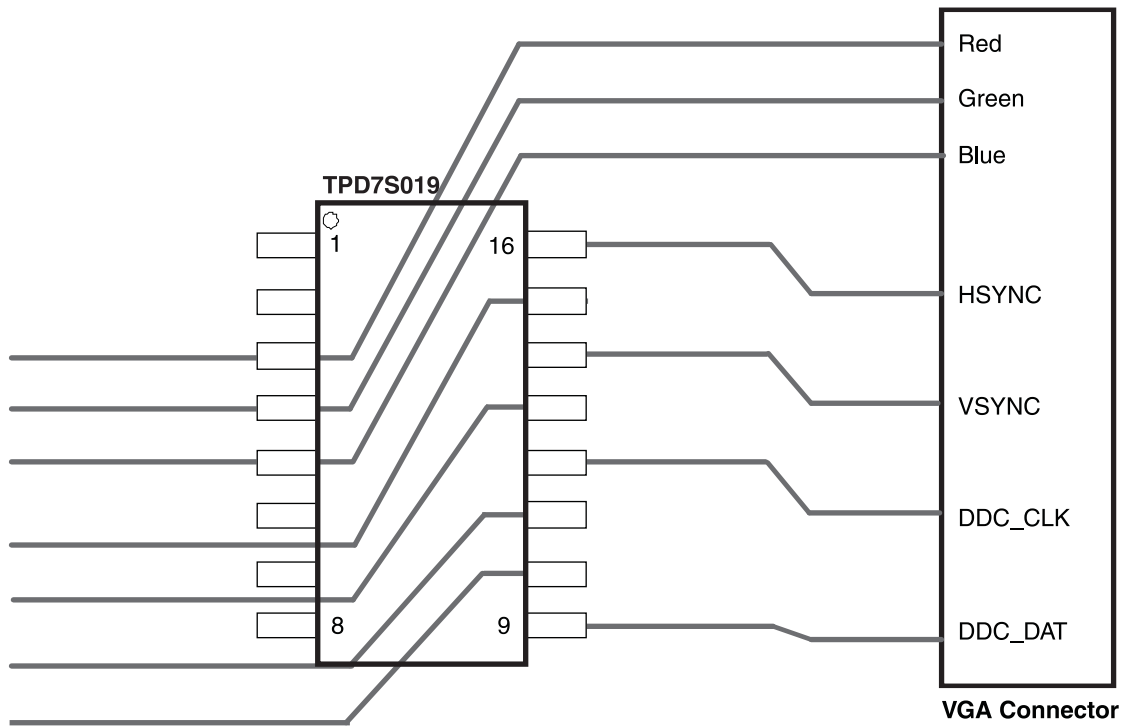

Figure 7. Simplified Layout with TPD7S019 (Only IO Lines are Shown)

PACKAGING INFORMATION

Orderable Device	Status ⁽¹⁾	Package Type	Package Drawing	Pins	Package Qty	Eco Plan ⁽²⁾	Lead/ Ball Finish	MSL Peak Temp ⁽³⁾	Samples (Requires Login)
TPD7S019-15DBQR	ACTIVE	SSOP/QSOP	DBQ	16	2500	Green (RoHS & no Sb/Br)	CU NIPDAU	Level-2-260C-1 YEAR	Request Free Samples
TPD7S019-55DBQR	PREVIEW	SSOP/QSOP	DBQ	16	2500	TBD	Call TI	Call TI	Samples Not Available
TPD7S019-65DBQR	PREVIEW	SSOP/QSOP	DBQ	16	2500	TBD	Call TI	Call TI	Samples Not Available

⁽¹⁾ The marketing status values are defined as follows:

ACTIVE: Product device recommended for new designs.

LIFEBUY: TI has announced that the device will be discontinued, and a lifetime-buy period is in effect.

NRND: Not recommended for new designs. Device is in production to support existing customers, but TI does not recommend using this part in a new design.

PREVIEW: Device has been announced but is not in production. Samples may or may not be available.

OBSELETE: TI has discontinued the production of the device.

⁽²⁾ Eco Plan - The planned eco-friendly classification: Pb-Free (RoHS), Pb-Free (RoHS Exempt), or Green (RoHS & no Sb/Br) - please check <http://www.ti.com/productcontent> for the latest availability information and additional product content details.

TBD: The Pb-Free/Green conversion plan has not been defined.

Pb-Free (RoHS): TI's terms "Lead-Free" or "Pb-Free" mean semiconductor products that are compatible with the current RoHS requirements for all 6 substances, including the requirement that lead not exceed 0.1% by weight in homogeneous materials. Where designed to be soldered at high temperatures, TI Pb-Free products are suitable for use in specified lead-free processes.

Pb-Free (RoHS Exempt): This component has a RoHS exemption for either 1) lead-based flip-chip solder bumps used between the die and package, or 2) lead-based die adhesive used between the die and leadframe. The component is otherwise considered Pb-Free (RoHS compatible) as defined above.

Green (RoHS & no Sb/Br): TI defines "Green" to mean Pb-Free (RoHS compatible), and free of Bromine (Br) and Antimony (Sb) based flame retardants (Br or Sb do not exceed 0.1% by weight in homogeneous material)

⁽³⁾ MSL, Peak Temp. -- The Moisture Sensitivity Level rating according to the JEDEC industry standard classifications, and peak solder temperature.

Important Information and Disclaimer: The information provided on this page represents TI's knowledge and belief as of the date that it is provided. TI bases its knowledge and belief on information provided by third parties, and makes no representation or warranty as to the accuracy of such information. Efforts are underway to better integrate information from third parties. TI has taken and continues to take reasonable steps to provide representative and accurate information but may not have conducted destructive testing or chemical analysis on incoming materials and chemicals. TI and TI suppliers consider certain information to be proprietary, and thus CAS numbers and other limited information may not be available for release.

In no event shall TI's liability arising out of such information exceed the total purchase price of the TI part(s) at issue in this document sold by TI to Customer on an annual basis.

DBQ (R-PDSO-G16)

PLASTIC SMALL-OUTLINE PACKAGE

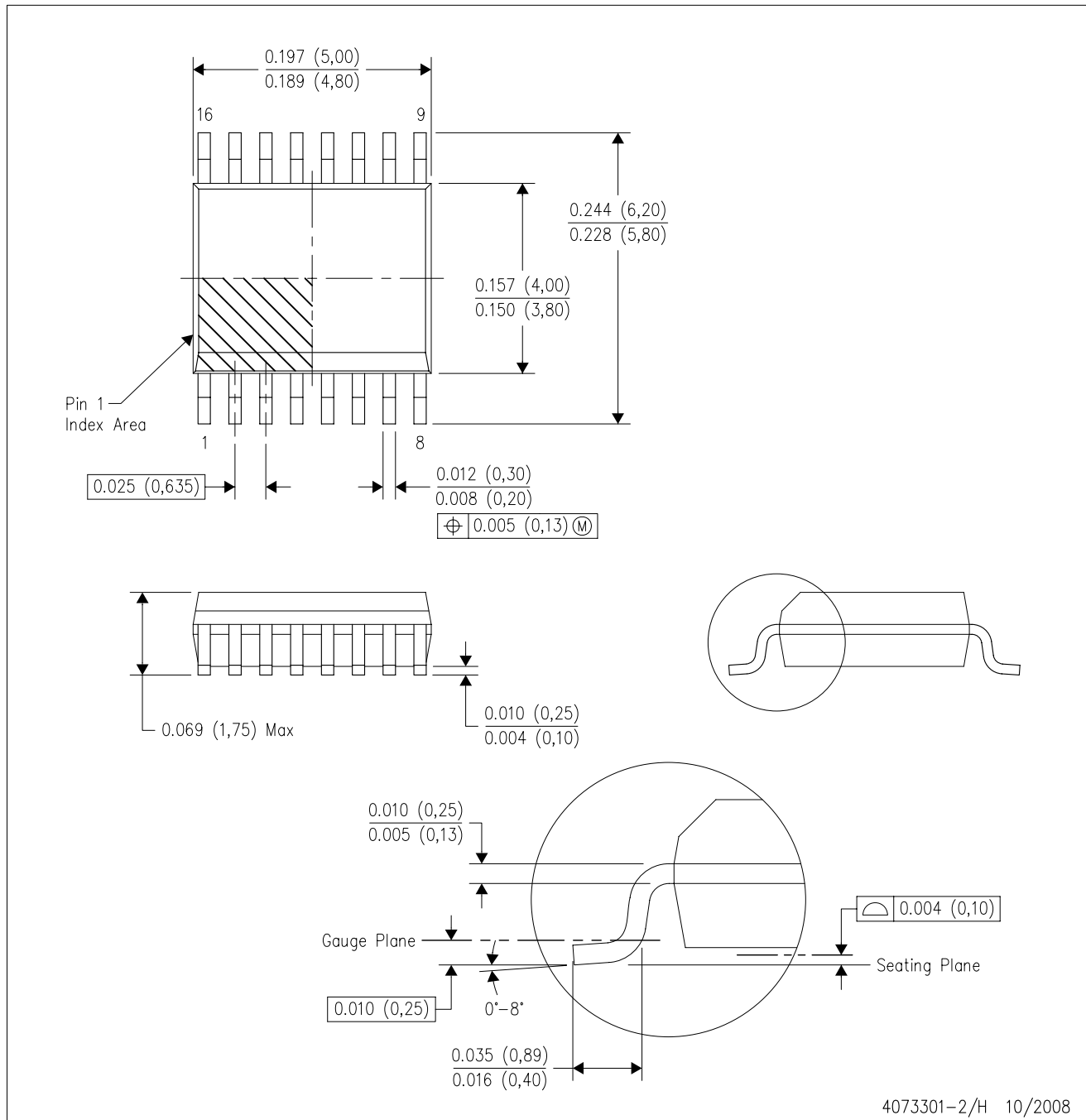

- NOTES:
- A. All linear dimensions are in inches (millimeters).
 - B. This drawing is subject to change without notice.
 - C. Body dimensions do not include mold flash or protrusion not to exceed 0.006 (0,15) per side.
 - D. Falls within JEDEC MO-137 variation AB.

DBQ (R-PDSO-G16)

PLASTIC SMALL OUTLINE PACKAGE

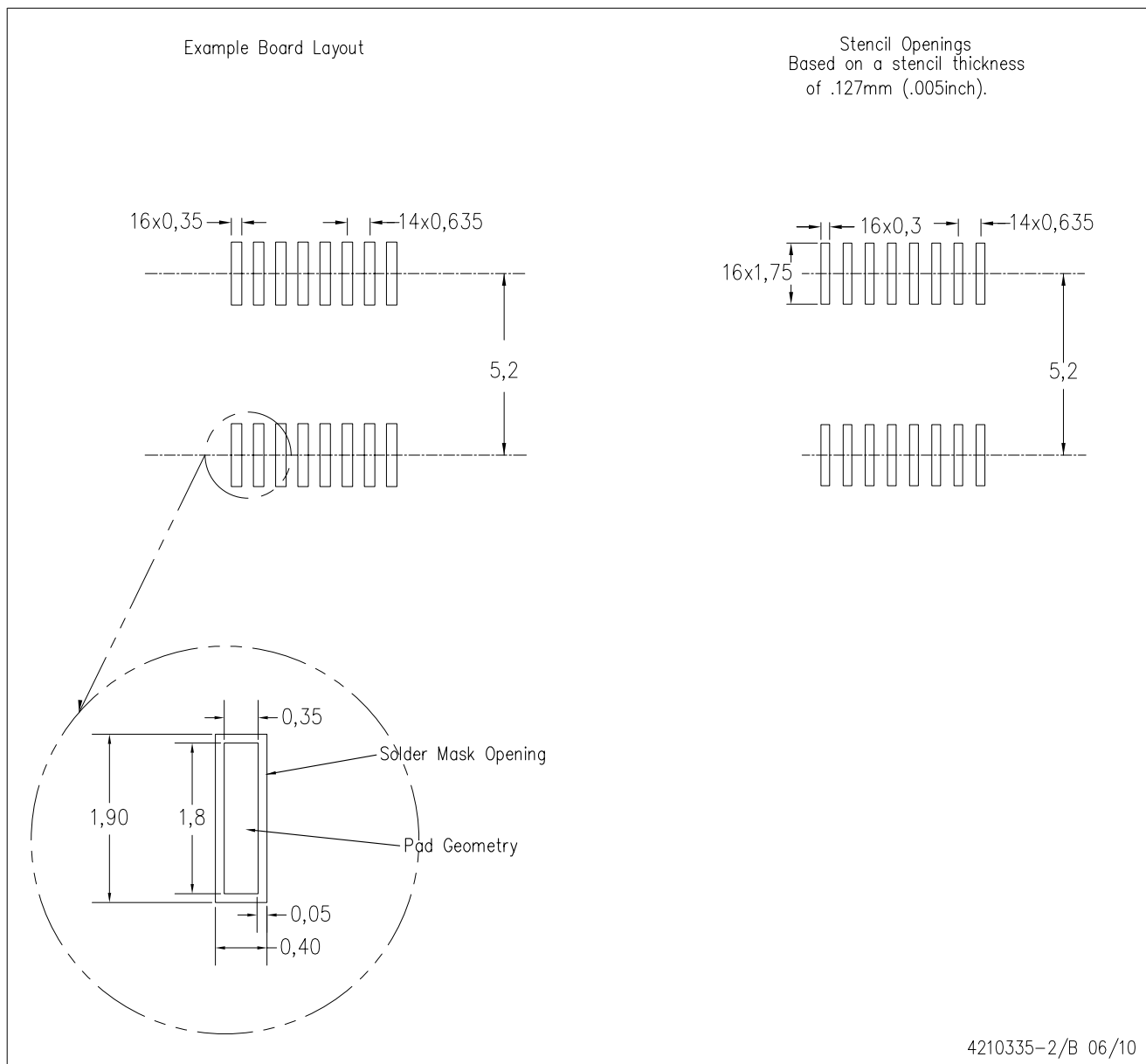

4210335-2/B 06/10

- NOTES:
- A. All linear dimensions are in millimeters.
 - B. This drawing is subject to change without notice.
 - C. Customers should place a note on the circuit board fabrication drawing not to alter the center solder mask defined pad.
 - D. Publication IPC-7351 is recommended for alternate designs.
 - E. Laser cutting apertures with trapezoidal walls and also rounding corners will offer better paste release. Customers should contact their board assembly site for stencil design recommendations. Example stencil design based on a 50% volumetric metal load solder paste. Refer to IPC-7525 for other stencil recommendations.

IMPORTANT NOTICE

Texas Instruments Incorporated and its subsidiaries (TI) reserve the right to make corrections, modifications, enhancements, improvements, and other changes to its products and services at any time and to discontinue any product or service without notice. Customers should obtain the latest relevant information before placing orders and should verify that such information is current and complete. All products are sold subject to TI's terms and conditions of sale supplied at the time of order acknowledgment.

TI warrants performance of its hardware products to the specifications applicable at the time of sale in accordance with TI's standard warranty. Testing and other quality control techniques are used to the extent TI deems necessary to support this warranty. Except where mandated by government requirements, testing of all parameters of each product is not necessarily performed.

TI assumes no liability for applications assistance or customer product design. Customers are responsible for their products and applications using TI components. To minimize the risks associated with customer products and applications, customers should provide adequate design and operating safeguards.

TI does not warrant or represent that any license, either express or implied, is granted under any TI patent right, copyright, mask work right, or other TI intellectual property right relating to any combination, machine, or process in which TI products or services are used. Information published by TI regarding third-party products or services does not constitute a license from TI to use such products or services or a warranty or endorsement thereof. Use of such information may require a license from a third party under the patents or other intellectual property of the third party, or a license from TI under the patents or other intellectual property of TI.

Reproduction of TI information in TI data books or data sheets is permissible only if reproduction is without alteration and is accompanied by all associated warranties, conditions, limitations, and notices. Reproduction of this information with alteration is an unfair and deceptive business practice. TI is not responsible or liable for such altered documentation. Information of third parties may be subject to additional restrictions.

Resale of TI products or services with statements different from or beyond the parameters stated by TI for that product or service voids all express and any implied warranties for the associated TI product or service and is an unfair and deceptive business practice. TI is not responsible or liable for any such statements.

TI products are not authorized for use in safety-critical applications (such as life support) where a failure of the TI product would reasonably be expected to cause severe personal injury or death, unless officers of the parties have executed an agreement specifically governing such use. Buyers represent that they have all necessary expertise in the safety and regulatory ramifications of their applications, and acknowledge and agree that they are solely responsible for all legal, regulatory and safety-related requirements concerning their products and any use of TI products in such safety-critical applications, notwithstanding any applications-related information or support that may be provided by TI. Further, Buyers must fully indemnify TI and its representatives against any damages arising out of the use of TI products in such safety-critical applications.

TI products are neither designed nor intended for use in military/aerospace applications or environments unless the TI products are specifically designated by TI as military-grade or "enhanced plastic." Only products designated by TI as military-grade meet military specifications. Buyers acknowledge and agree that any such use of TI products which TI has not designated as military-grade is solely at the Buyer's risk, and that they are solely responsible for compliance with all legal and regulatory requirements in connection with such use.

TI products are neither designed nor intended for use in automotive applications or environments unless the specific TI products are designated by TI as compliant with ISO/TS 16949 requirements. Buyers acknowledge and agree that, if they use any non-designated products in automotive applications, TI will not be responsible for any failure to meet such requirements.

Following are URLs where you can obtain information on other Texas Instruments products and application solutions:

Products		Applications	
Amplifiers	amplifier.ti.com	Audio	www.ti.com/audio
Data Converters	dataconverter.ti.com	Automotive	www.ti.com/automotive
DLP® Products	www.dlp.com	Communications and Telecom	www.ti.com/communications
DSP	dsp.ti.com	Computers and Peripherals	www.ti.com/computers
Clocks and Timers	www.ti.com/clocks	Consumer Electronics	www.ti.com/consumer-apps
Interface	interface.ti.com	Energy	www.ti.com/energy
Logic	logic.ti.com	Industrial	www.ti.com/industrial
Power Mgmt	power.ti.com	Medical	www.ti.com/medical
Microcontrollers	microcontroller.ti.com	Security	www.ti.com/security
RFID	www.ti-rfid.com	Space, Avionics & Defense	www.ti.com/space-avionics-defense
RF/IF and ZigBee® Solutions	www.ti.com/lprf	Video and Imaging	www.ti.com/video
		Wireless	www.ti.com/wireless-apps

Mailing Address: Texas Instruments, Post Office Box 655303, Dallas, Texas 75265
Copyright © 2010, Texas Instruments Incorporated