

## 2-CHANNEL ESD SOLUTION FOR HIGH-SPEED (6 GBPS) DIFFERENTIAL INTERFACE

### FEATURES

- 0.05-pF Matching Capacitance Between the Differential Signal Pair
- Single-Pair Differential Lines to Protect the Differential Data and Clock Lines of the LVDS, SATA, Ethernet, or USB High-Speed (HS) Interface
- Flow-Through Pin Mapping for the High-Speed Lines Ensures Zero Additional Skew Due to Board Layout While Placing ESD-Protection Chip Near the Connector
- Supports Data Rates in Excess of 6 Gbps
- ESD Protection Meets or Exceeds IEC61000-4-2 (Level 4)
- 5-A Peak Pulse Current (8/20  $\mu$ s Pulse) for  $V_{BUS}$  and D+, D–, and ID Lines
- Industrial Temperature Range: –40°C to 85°C
- Multiple Space-Saving Package Options

### APPLICATIONS

- Notebooks
- Set-Top Boxes
- DVD Players
- Media Players
- Portable Computers

### DESCRIPTION/ORDERING INFORMATION

The TPD2E009 provides 2 ESD clamp circuits with flow-through pin mapping for ease of board layout. This device has been designed to protect sensitive components which are connected to ultra high-speed data and transmission lines. The TPD2E009 offers protection from stress caused by ESD (electrostatic discharge). This device also offers 5 A (8/20  $\mu$ s) peak pulse current ratings per IEC 61000-4-5 (lightning) specification.

The monolithic silicon technology allows matching between the differential signal pairs. The less than differential 0.05-pF capacitance ensures that the differential signal distortion due to added ESD clamp remains minimal. The 0.7-pF line capacitance is suitable for high-speed data rate (in excess of 6 Gbps).

The TPD2E009 conforms to IEC61000-4-2 (Level 4) ESD protection. The DRT (1 mm  $\times$  1 mm) package is offered for space-saving portable applications. The industry standard DBZ (2.4 mm  $\times$  2.9 mm) package offers additional flexibility in the board layout for the system designer.

The TPD2E009 is characterized for operation over ambient air temperature range of –40°C to 85°C.

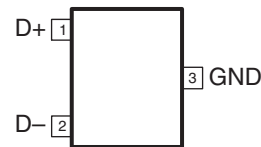
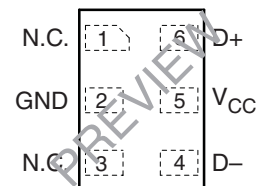
**DBZ/DRT PACKAGE  
(TOP VIEW)**

**DRY PACKAGE  
(TOP VIEW)**

N.C. – No internal connection



Please be aware that an important notice concerning availability, standard warranty, and use in critical applications of Texas Instruments semiconductor products and disclaimers thereto appears at the end of this data sheet.

**ORDERING INFORMATION**

T <sub>A</sub>	PACKAGE <sup>(1)(2)</sup>		ORDERABLE PART NUMBER	TOP-SIDE MARKING
–40°C to 85°C	SON – DRY	Tape and reel	TPD2E009DRYR	PREVIEW
	SOP – DBZ	Tape and reel	TPD2E009DBZR	NFLR
	SOT– DRT	Tape and reel	TPD2E009DRTR	4T

- (1) Package drawings, thermal data, and symbolization are available at [www.ti.com/packaging](http://www.ti.com/packaging).
- (2) For the most current package and ordering information, see the Package Option Addendum at the end of this document, or see the TI website at [www.ti.com](http://www.ti.com).

**CIRCUIT DIAGRAMS**

**DRY Circuit**

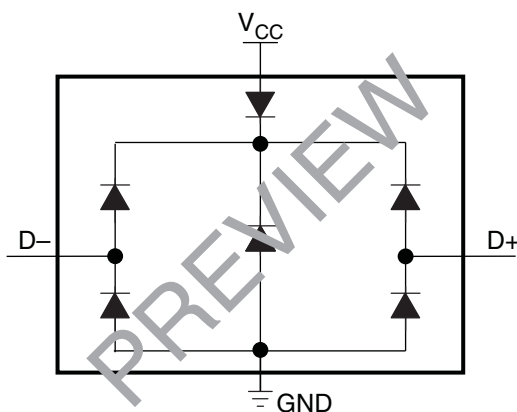

**DBZ/DRT Circuit**

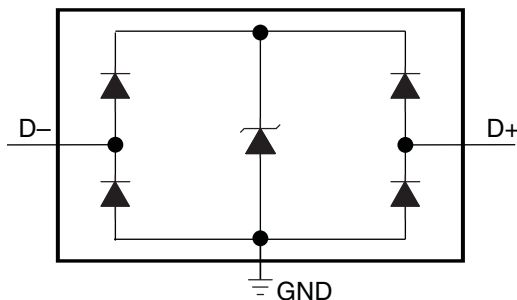

**TERMINAL FUNCTIONS**

NAME	TERMINAL		TYPE	DESCRIPTION
	DBZ/DRT PIN NO.	DRY <sup>(1)</sup> PIN NO.		
D+, D-	1, 2	4, 6	ESD port	High-speed ESD clamp, provides ESD protection to the high-speed differential data lines
V <sub>CC</sub>	–	5	Supply	Power supply
GND	3	3	GND	Ground

(1) Product Preview

## ABSOLUTE MAXIMUM RATINGS<sup>(1)</sup>

over operating free-air temperature range (unless otherwise noted)

			MIN	MAX	UNIT
	IO voltage tolerance	D+, D– pins	0	6	
T <sub>A</sub>	Operating free-air temperature range		–40	85	°C
T <sub>stg</sub>	Storage temperature range		–65	125	°C
ESD protection	IEC 61000-4-2 Contact Discharge	D+, D– pins		±8	kV
	IEC 61000-4-2 Air-Gap Discharge	D+, D– pins		±8	kV
	Peak pulse current (t <sub>p</sub> = 8/20 μs)	D+, D– pins		5	A
	Peak pulse power (t <sub>p</sub> = 8/20 μs)	D+, D– pins		45	W

(1) Stresses beyond those listed under "absolute maximum ratings" may cause permanent damage to the device. These are stress ratings only, and functional operation of the device at these or any other conditions beyond those indicated in the operational sections of the specifications is not implied. Exposure to absolute maximum-rated conditions for extended periods may affect device reliability.

## ELECTRICAL CHARACTERISTICS

over operating free-air temperature range (unless otherwise noted)

PARAMETER		TEST CONDITIONS		MIN	TYP	MAX	UNIT
V <sub>RWM</sub>	Reverse stand-off voltage	D+,D– pins to ground				5.5	V
V <sub>clamp</sub>	Clamp voltage	D+,D– pins to ground, I <sub>IO</sub> = 1 A				8	V
I <sub>IO</sub>	Current from IO port to supply pins	V <sub>IO</sub> = 2.5 V, I <sub>D</sub> = 8 mA			0.01	0.1	μA
V <sub>D</sub>	Diode forward voltage	D+,D– pins, lower clamp diode,	V <sub>IO</sub> = 2.5 V, I <sub>D</sub> = 8 mA	0.6	0.8	0.95	V
		D+,D– pins, upper clamp diode, DRY package	V <sub>CC</sub> = 0 V, I <sub>D</sub> = –8 mA	0.6	0.8	0.95	
R <sub>dyn</sub>	Dynamic resistance	D+,D– pins, I = 1 A			1		Ω
C <sub>IO</sub>	IO capacitance	D+,D– pins, DBZ Package		V <sub>IO</sub> = 2.5 V		0.9	pF
		D+,D– pins, DRT Package		V <sub>IO</sub> = 2.5 V		0.7	pF
V <sub>BR</sub>	Break-down voltage	I <sub>IO</sub> = 1 mA		7			V

TYPICAL OPERATING CHARACTERISTICS

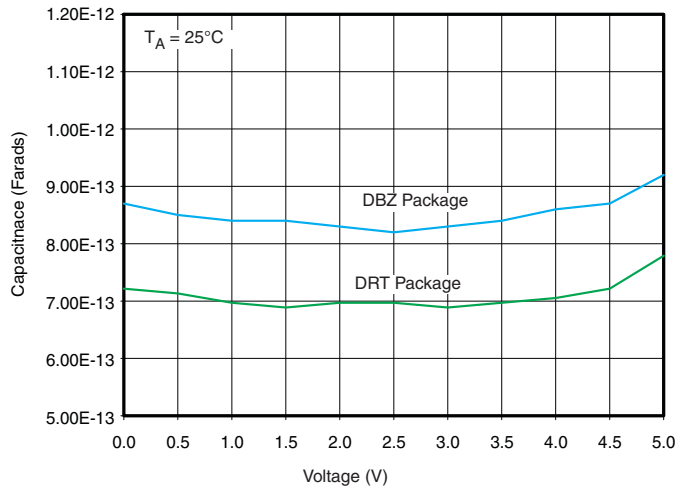

Figure 1. IO Capacitance vs IO Voltage

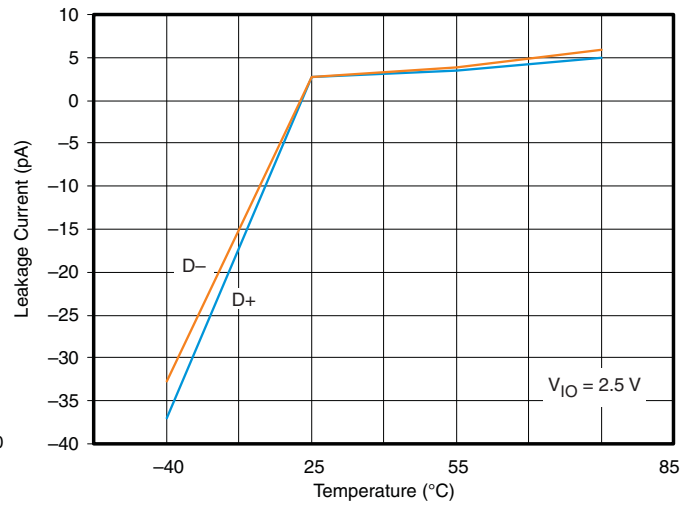

Figure 2. Leakage Current vs Temperature

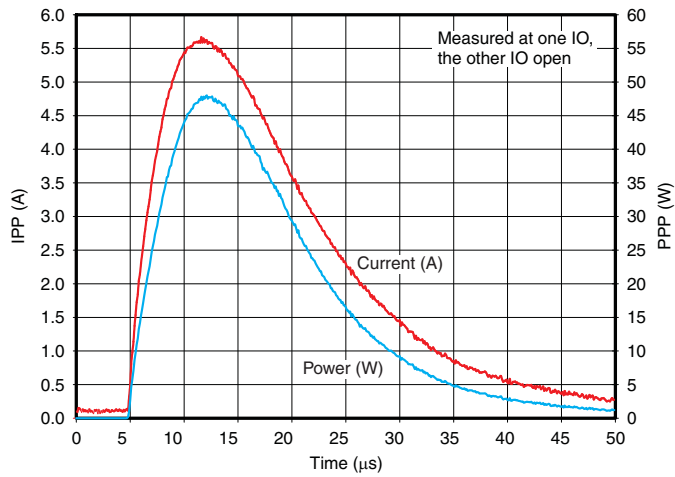

Figure 3. Peak Pulse Waveforms

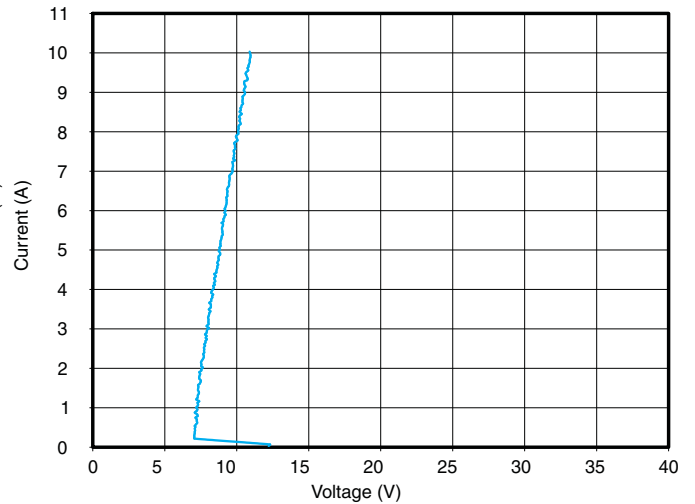

Figure 4. D+, D- Transmission Line Pulser Plot (100 ns Pulse, 10 ns Rise Time)

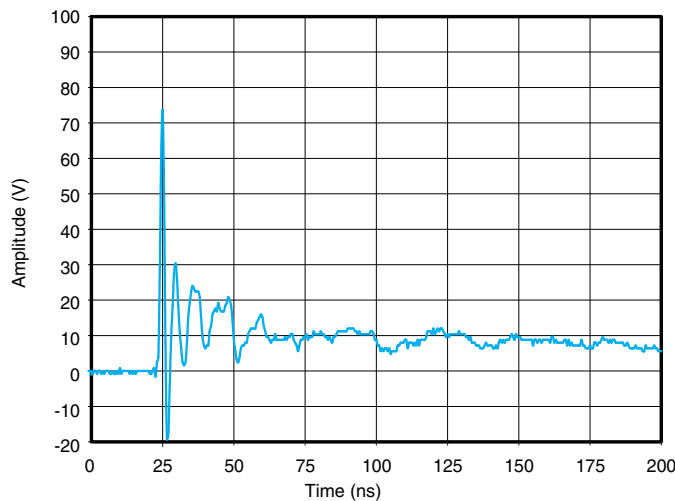

Figure 5. IEC Clamping Waveforms (8 kV Contact)

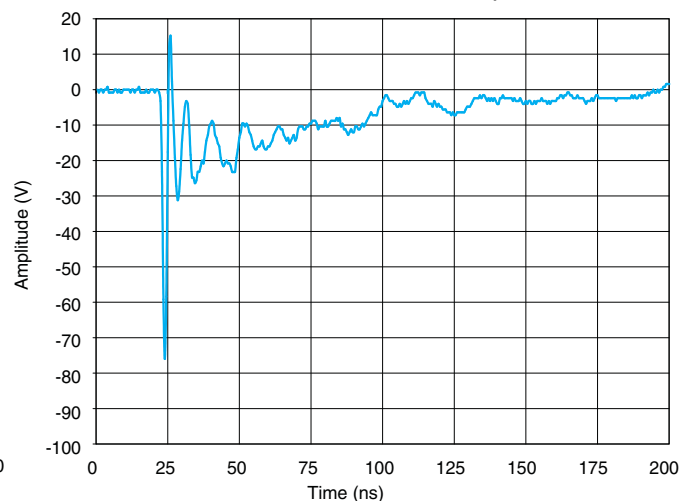

Figure 6. IEC Clamping Waveforms (-8 kV Contact)

TYPICAL OPERATING CHARACTERISTICS (continued)

Eye Diagrams

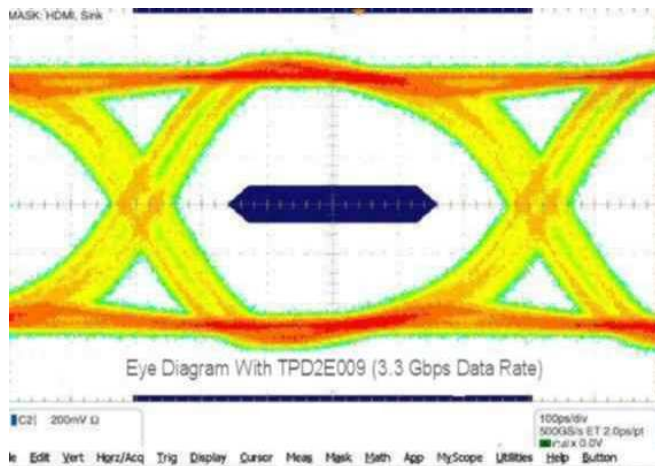

Figure 7. Eye Diagram With TPD2E009 (3.3 Gbps Data Rate) (3-Pin DBZ Package)

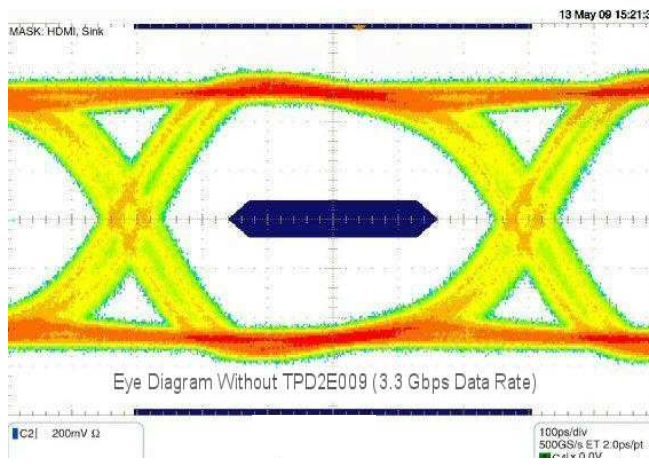

Figure 8. Eye Diagram Without TPD2E009 (3.3 Gbps Data Rate) (3-Pin DBZ Package)

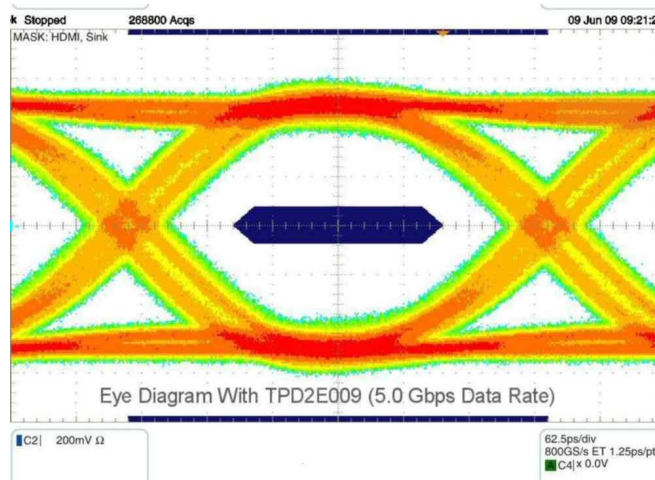

Figure 9. Eye Diagram With TPD2E009 (5.0 Gbps Data Rate) (3-Pin DBZ Package)

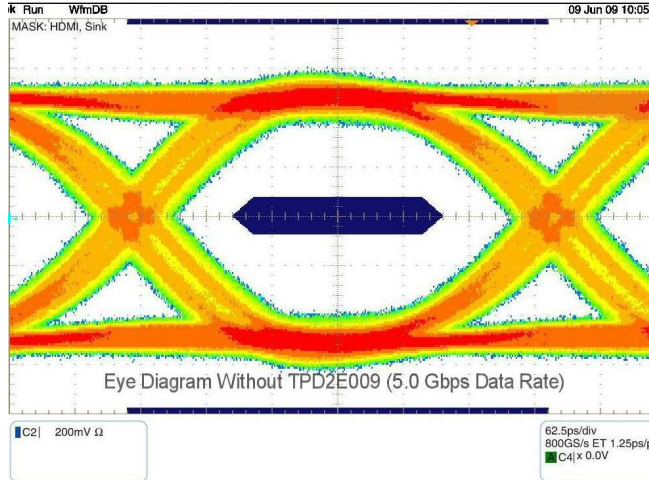
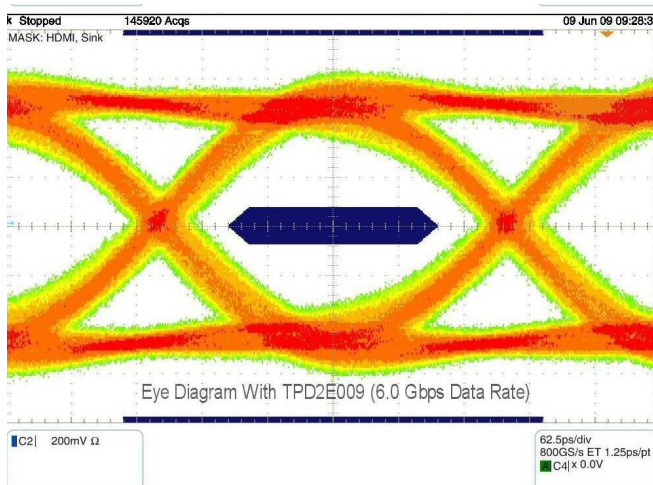
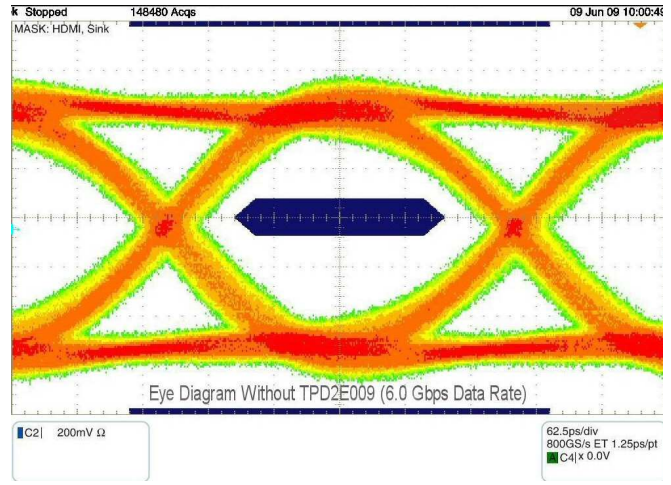

Figure 10. Eye Diagram Without TPD2E009 (5.0 Gbps Data Rate) (3-Pin DBZ Package)

**TYPICAL OPERATING CHARACTERISTICS (continued)**



**Figure 11. Eye Diagram With TPD2E009  
(6.0 Gbps Data Rate)  
(3-Pin DBZ Package)**



**Figure 12. Eye Diagram Without TPD2E009  
(6.0 Gbps Data Rate)  
(3-Pin DBZ Package)**

## APPLICATION INFORMATION

### Typical Application

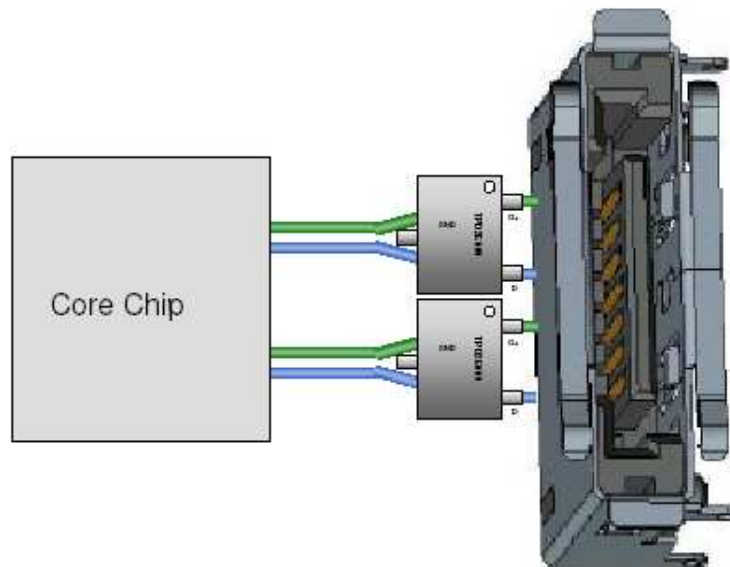

**Figure 13. TPD2E009 in Differential eSATA Interface**

Figure 13 shows the board layout scheme for the D+/D- lines of a single differential pair. It allows the differential signal pairs couple together right after they touch the ESD ports (pin 1 and pin 2) of the TPD2E009.

### Designing with High-Speed Differential Signals

Layout considerations, such as package selection, trace routing, etc. must be taken into account while designing the ESD clamp circuit for high-speed interface. Difficult routing can lead the designer to use vias or stubs in the board traces, creating significant disruption in the line impedance in the high-speed signal path. Poor package choice can force designer to route differential traces with unequal lengths and add the skew in the signals. It is recommended to closely couple the differential traces to reduce the EMI interference.

The TPD2E009 can provide system level ESD protection to the high-speed differential ports (>6 Gbps data rate). The flow-through package offers flexibility for board routing with traces up to 15 mills wide. Figure 14 and Figure 15 show the board layout scheme for the D+/D- lines of a single differential pair. It allows the differential signal pairs couple together right after they touch the ESD ports (pin 1 and pin 2) of the TPD2E009.

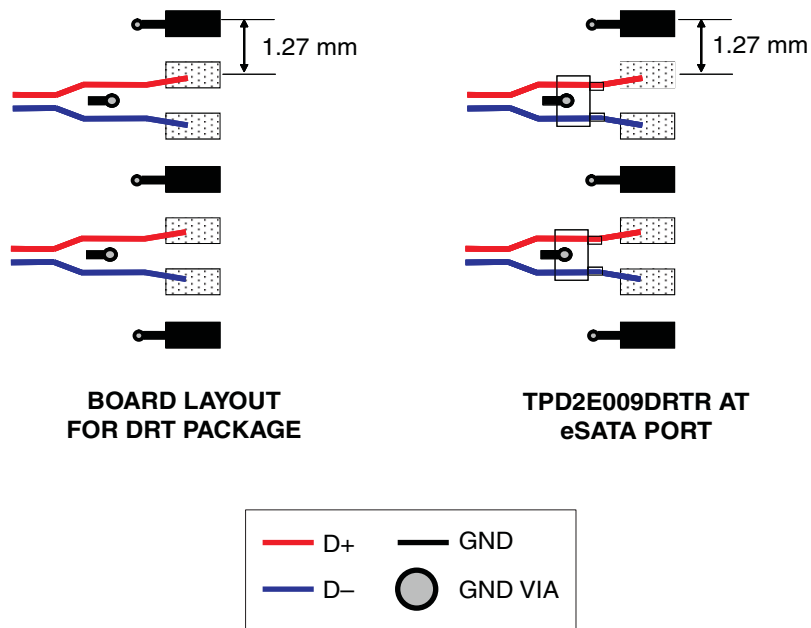

Figure 14. TPD2E009DRTR at eSATA Connector Interface

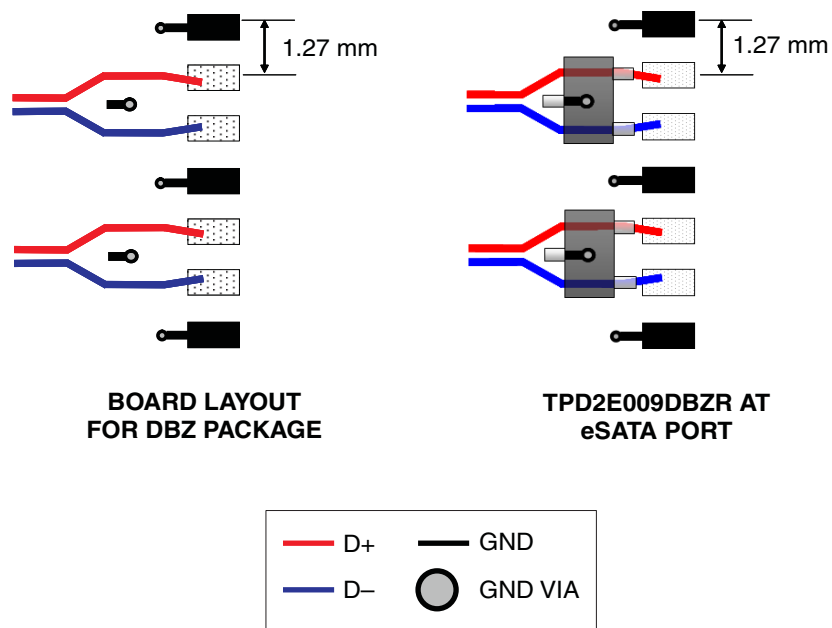

Figure 15. TPD2E009DBZR at eSATA Connector Interface

**PACKAGING INFORMATION**

Orderable Device	Status (1)	Package Type	Package Drawing	Pins	Package Qty	Eco Plan (2)	Lead/Ball Finish (6)	MSL Peak Temp (3)	Op Temp (°C)	Device Marking (4/5)	Samples
TPD2E009DBZR	ACTIVE	SOT-23	DBZ	3	3000	Green (RoHS & no Sb/Br)	CU NIPDAU	Level-1-260C-UNLIM	-40 to 85	(NFLO ~ NFLR)	<a href="#">Samples</a>
TPD2E009DRTR	ACTIVE	SOT	DRT	3	3000	Green (RoHS & no Sb/Br)	CU NIPDAU	Level-1-260C-UNLIM	-40 to 85	4T	<a href="#">Samples</a>

(1) The marketing status values are defined as follows:

**ACTIVE:** Product device recommended for new designs.

**LIFEBUY:** TI has announced that the device will be discontinued, and a lifetime-buy period is in effect.

**NRND:** Not recommended for new designs. Device is in production to support existing customers, but TI does not recommend using this part in a new design.

**PREVIEW:** Device has been announced but is not in production. Samples may or may not be available.

**OBSOLETE:** TI has discontinued the production of the device.

(2) Eco Plan - The planned eco-friendly classification: Pb-Free (RoHS), Pb-Free (RoHS Exempt), or Green (RoHS & no Sb/Br) - please check <http://www.ti.com/productcontent> for the latest availability information and additional product content details.

**TBD:** The Pb-Free/Green conversion plan has not been defined.

**Pb-Free (RoHS):** TI's terms "Lead-Free" or "Pb-Free" mean semiconductor products that are compatible with the current RoHS requirements for all 6 substances, including the requirement that lead not exceed 0.1% by weight in homogeneous materials. Where designed to be soldered at high temperatures, TI Pb-Free products are suitable for use in specified lead-free processes.

**Pb-Free (RoHS Exempt):** This component has a RoHS exemption for either 1) lead-based flip-chip solder bumps used between the die and package, or 2) lead-based die adhesive used between the die and leadframe. The component is otherwise considered Pb-Free (RoHS compatible) as defined above.

**Green (RoHS & no Sb/Br):** TI defines "Green" to mean Pb-Free (RoHS compatible), and free of Bromine (Br) and Antimony (Sb) based flame retardants (Br or Sb do not exceed 0.1% by weight in homogeneous material)

(3) MSL, Peak Temp. - The Moisture Sensitivity Level rating according to the JEDEC industry standard classifications, and peak solder temperature.

(4) There may be additional marking, which relates to the logo, the lot trace code information, or the environmental category on the device.

(5) Multiple Device Markings will be inside parentheses. Only one Device Marking contained in parentheses and separated by a "~" will appear on a device. If a line is indented then it is a continuation of the previous line and the two combined represent the entire Device Marking for that device.

(6) Lead/Ball Finish - Orderable Devices may have multiple material finish options. Finish options are separated by a vertical ruled line. Lead/Ball Finish values may wrap to two lines if the finish value exceeds the maximum column width.

**Important Information and Disclaimer:** The information provided on this page represents TI's knowledge and belief as of the date that it is provided. TI bases its knowledge and belief on information provided by third parties, and makes no representation or warranty as to the accuracy of such information. Efforts are underway to better integrate information from third parties. TI has taken and continues to take reasonable steps to provide representative and accurate information but may not have conducted destructive testing or chemical analysis on incoming materials and chemicals. TI and TI suppliers consider certain information to be proprietary, and thus CAS numbers and other limited information may not be available for release.

In no event shall TI's liability arising out of such information exceed the total purchase price of the TI part(s) at issue in this document sold by TI to Customer on an annual basis.

**TAPE AND REEL INFORMATION**
**REEL DIMENSIONS**

**TAPE DIMENSIONS**

A0	Dimension designed to accommodate the component width
B0	Dimension designed to accommodate the component length
K0	Dimension designed to accommodate the component thickness
W	Overall width of the carrier tape
P1	Pitch between successive cavity centers

**TAPE AND REEL INFORMATION**

\*All dimensions are nominal

Device	Package Type	Package Drawing	Pins	SPQ	Reel Diameter (mm)	Reel Width W1 (mm)	A0 (mm)	B0 (mm)	K0 (mm)	P1 (mm)	W (mm)	Pin1 Quadrant
TPD2E009DBZR	SOT-23	DBZ	3	3000	180.0	8.4	3.15	2.77	1.22	4.0	8.0	Q3
TPD2E009DRTR	SOT	DRT	3	3000	180.0	8.4	1.16	1.16	0.63	4.0	8.0	Q3

**TAPE AND REEL BOX DIMENSIONS**

\*All dimensions are nominal

Device	Package Type	Package Drawing	Pins	SPQ	Length (mm)	Width (mm)	Height (mm)
TPD2E009DBZR	SOT-23	DBZ	3	3000	202.0	201.0	28.0
TPD2E009DRTR	SOT	DRT	3	3000	202.0	201.0	85.0

DBZ (R-PDSO-G3)

PLASTIC SMALL-OUTLINE

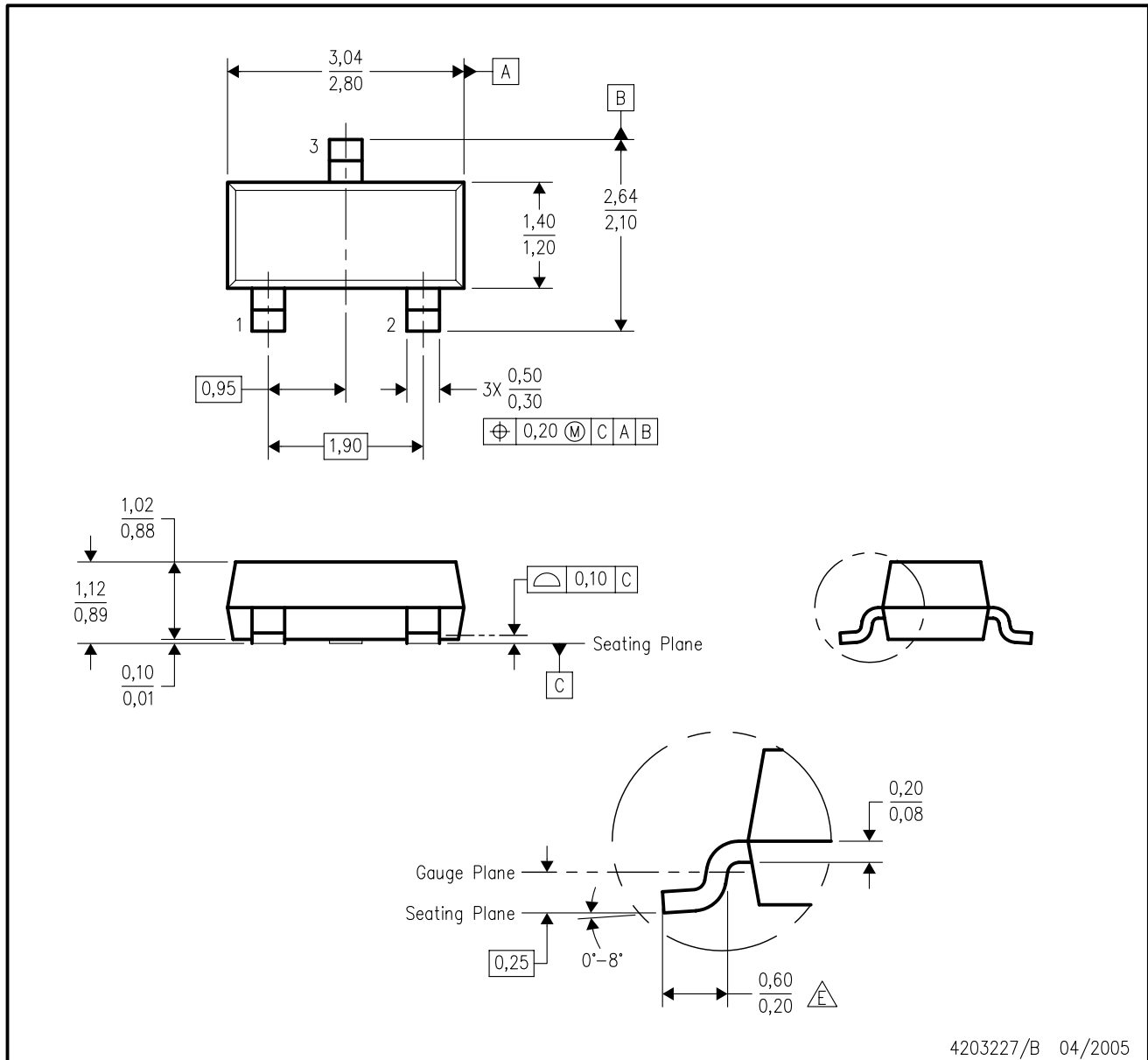

- NOTES:
- A. All linear dimensions are in millimeters. Dimensioning and tolerancing per ASME Y14.5M-1994.
  - B. This drawing is subject to change without notice.
  - C. Lead dimensions are inclusive of plating.
  - D. Body dimensions are exclusive of mold flash and protrusion. Mold flash and protrusion not to exceed 0.25 per side.
  - Falls within JEDEC TO-236 variation AB, except minimum foot length.

DBZ (R-PDSO-G3)

PLASTIC SMALL OUTLINE

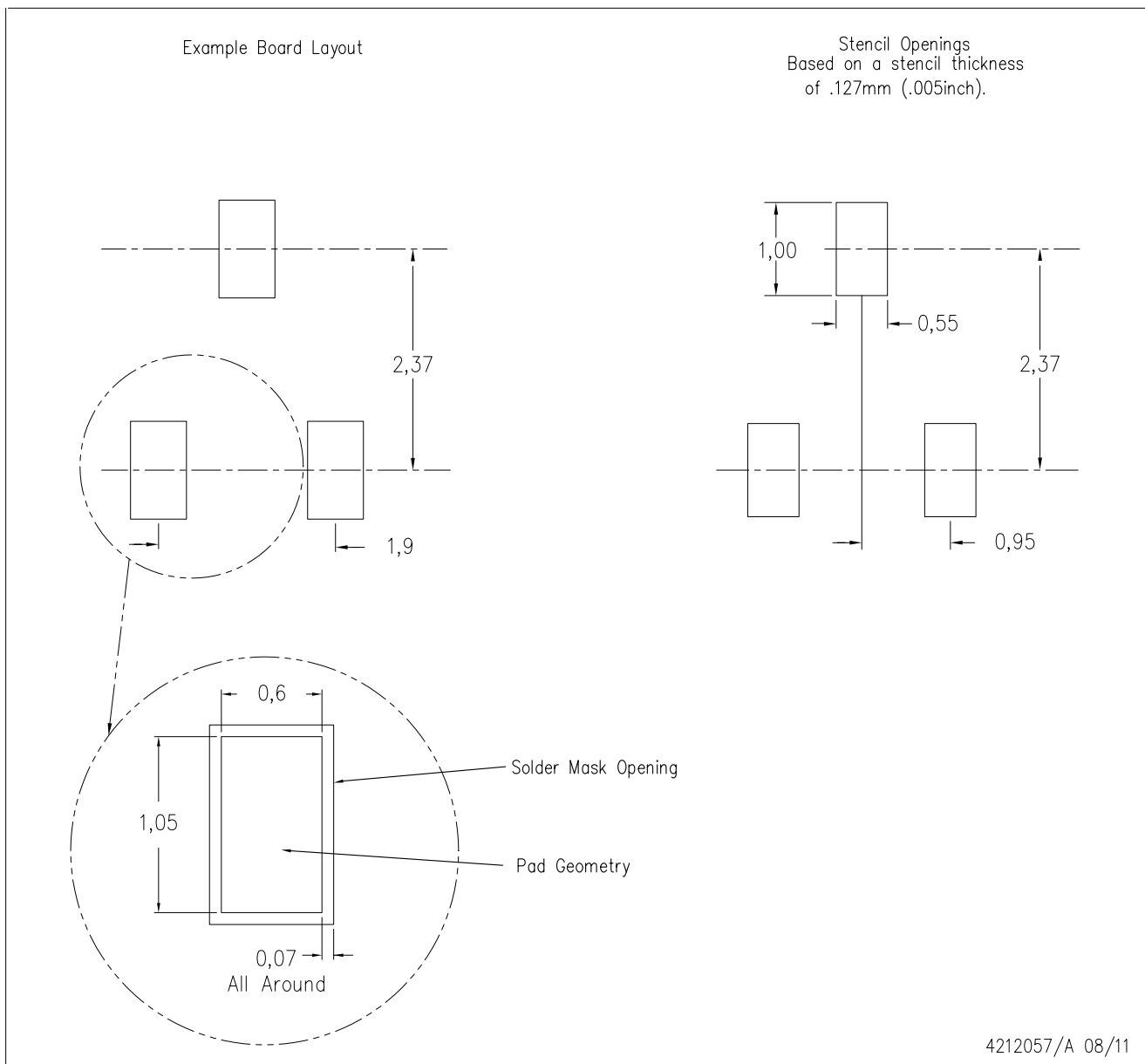

- NOTES:
- A. All linear dimensions are in millimeters.
  - B. This drawing is subject to change without notice.
  - C. Customers should place a note on the circuit board fabrication drawing not to alter the center solder mask defined pad.
  - D. Publication IPC-7351 is recommended for alternate designs.
  - E. Laser cutting apertures with trapezoidal walls and also rounding corners will offer better paste release. Customers should contact their board assembly site for stencil design recommendations. Example stencil design based on a 50% volumetric metal load solder paste. Refer to IPC-7525 for other stencil recommendations.

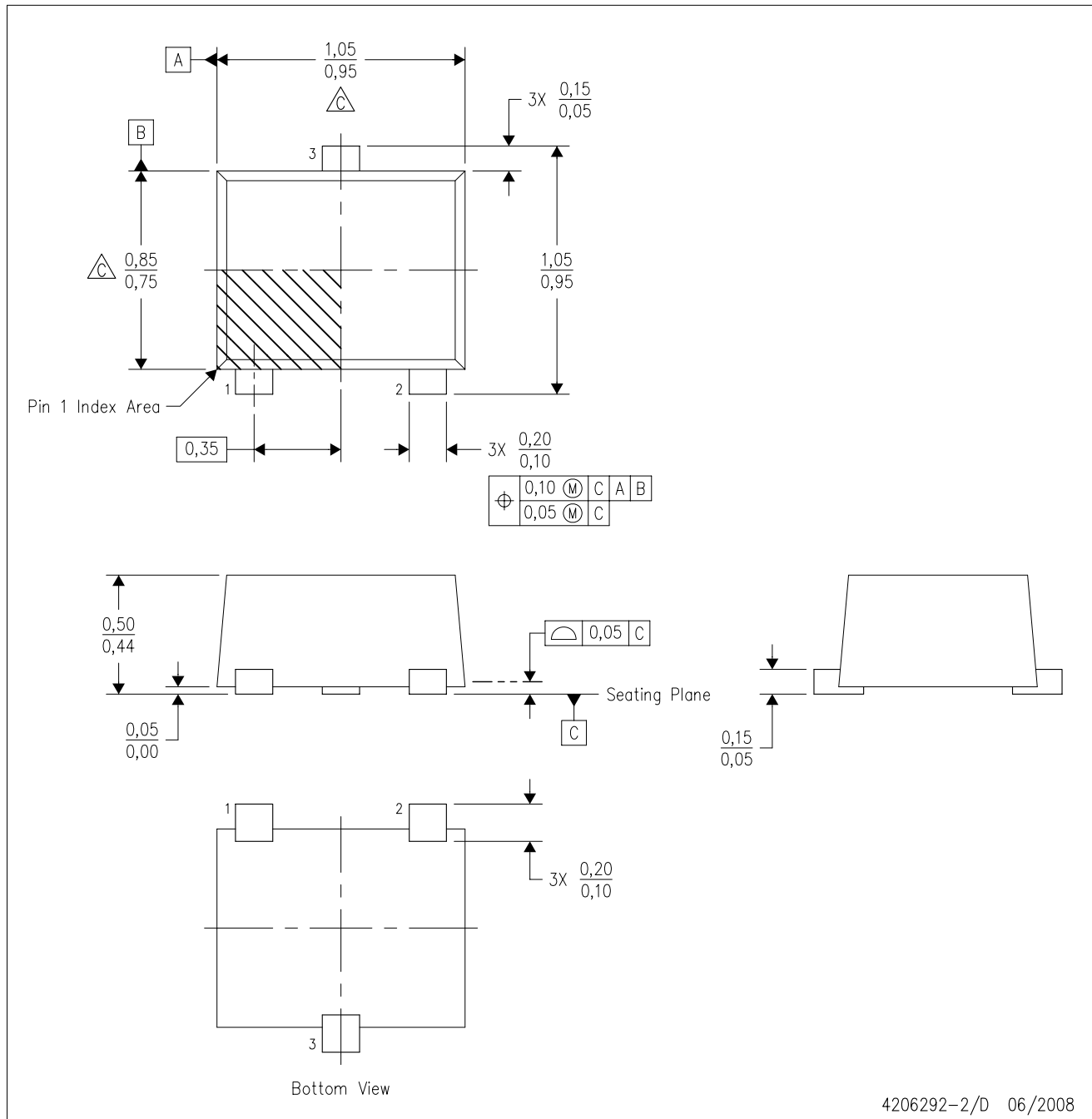

- NOTES:
- A. All linear dimensions are in millimeters. Dimensioning and tolerancing per ASME Y14.5M-1994.
  - B. This drawing is subject to change without notice.
  - $\triangle$  Body dimensions do not include mold flash, interlead flash, protrusions, or gate burrs. Mold flash, interlead flash, protrusions, or gate burrs shall not exceed 0,10 per end or side.
  - D. JEDEC package registration is pending.

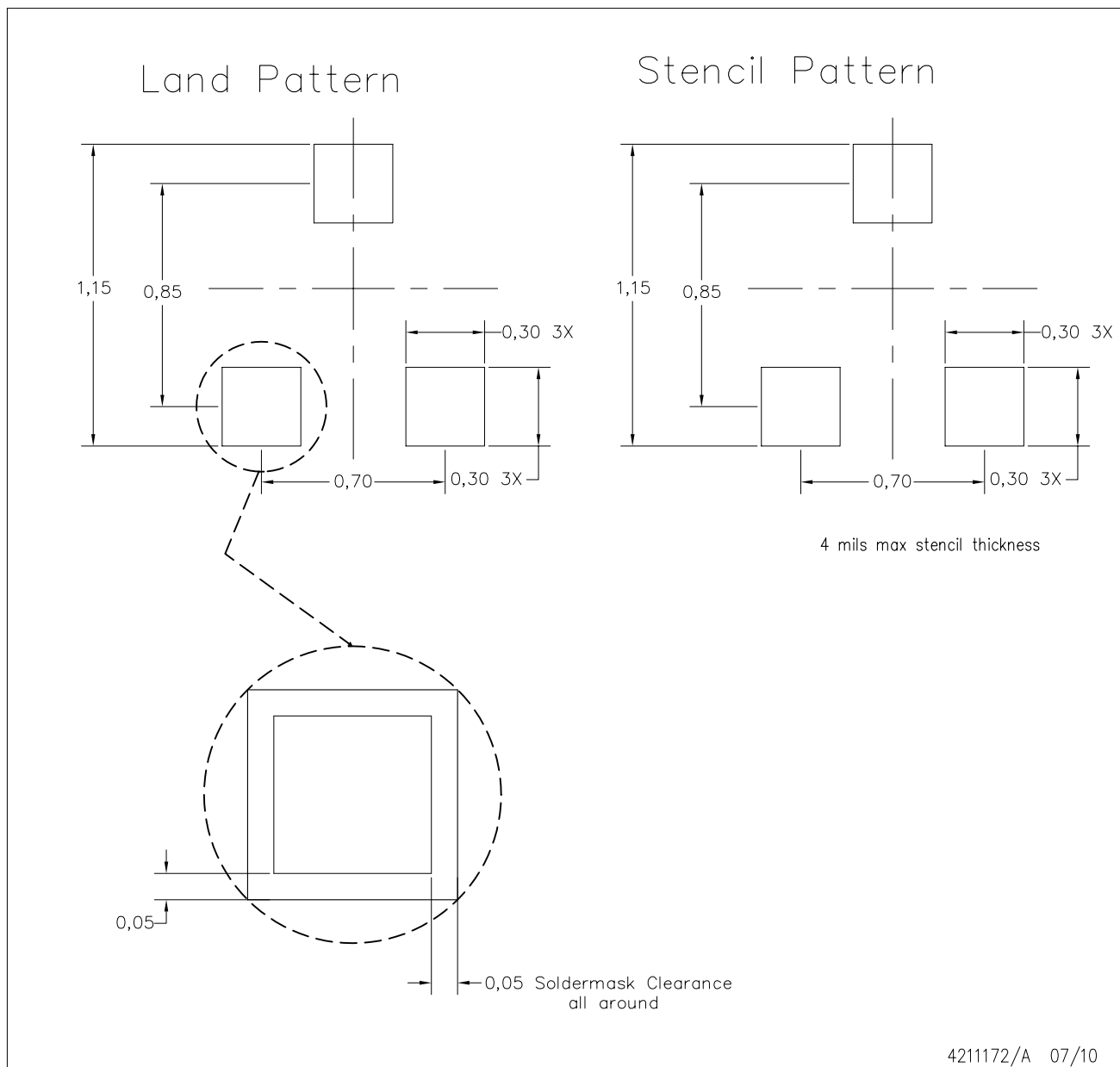

4211172/A 07/10

- NOTES:
- All linear dimensions are in millimeters.
  - This drawing is subject to change without notice.
  - Publication IPC-7351 is recommended for alternate designs.
  - Customers should contact their board fabrication site for minimum solder mask web tolerances between signal pads.
  - Maximum stencil thickness 0,1016 mm (4 mils). All linear dimensions are in millimeters.
  - Laser cutting apertures with trapezoidal walls and also rounding corners will offer better paste release. Customers should contact their board assembly site for stencil design recommendations. Refer to IPC 7525 for stencil design considerations.
  - Side aperture dimensions over-print land for acceptable area ratio > 0.66. Customer may reduce side aperture dimensions if stencil manufacturing process allows for sufficient release at smaller opening.

## IMPORTANT NOTICE

Texas Instruments Incorporated and its subsidiaries (TI) reserve the right to make corrections, enhancements, improvements and other changes to its semiconductor products and services per JESD46, latest issue, and to discontinue any product or service per JESD48, latest issue. Buyers should obtain the latest relevant information before placing orders and should verify that such information is current and complete. All semiconductor products (also referred to herein as "components") are sold subject to TI's terms and conditions of sale supplied at the time of order acknowledgment.

TI warrants performance of its components to the specifications applicable at the time of sale, in accordance with the warranty in TI's terms and conditions of sale of semiconductor products. Testing and other quality control techniques are used to the extent TI deems necessary to support this warranty. Except where mandated by applicable law, testing of all parameters of each component is not necessarily performed.

TI assumes no liability for applications assistance or the design of Buyers' products. Buyers are responsible for their products and applications using TI components. To minimize the risks associated with Buyers' products and applications, Buyers should provide adequate design and operating safeguards.

TI does not warrant or represent that any license, either express or implied, is granted under any patent right, copyright, mask work right, or other intellectual property right relating to any combination, machine, or process in which TI components or services are used. Information published by TI regarding third-party products or services does not constitute a license to use such products or services or a warranty or endorsement thereof. Use of such information may require a license from a third party under the patents or other intellectual property of the third party, or a license from TI under the patents or other intellectual property of TI.

Reproduction of significant portions of TI information in TI data books or data sheets is permissible only if reproduction is without alteration and is accompanied by all associated warranties, conditions, limitations, and notices. TI is not responsible or liable for such altered documentation. Information of third parties may be subject to additional restrictions.

Resale of TI components or services with statements different from or beyond the parameters stated by TI for that component or service voids all express and any implied warranties for the associated TI component or service and is an unfair and deceptive business practice. TI is not responsible or liable for any such statements.

Buyer acknowledges and agrees that it is solely responsible for compliance with all legal, regulatory and safety-related requirements concerning its products, and any use of TI components in its applications, notwithstanding any applications-related information or support that may be provided by TI. Buyer represents and agrees that it has all the necessary expertise to create and implement safeguards which anticipate dangerous consequences of failures, monitor failures and their consequences, lessen the likelihood of failures that might cause harm and take appropriate remedial actions. Buyer will fully indemnify TI and its representatives against any damages arising out of the use of any TI components in safety-critical applications.

In some cases, TI components may be promoted specifically to facilitate safety-related applications. With such components, TI's goal is to help enable customers to design and create their own end-product solutions that meet applicable functional safety standards and requirements. Nonetheless, such components are subject to these terms.

No TI components are authorized for use in FDA Class III (or similar life-critical medical equipment) unless authorized officers of the parties have executed a special agreement specifically governing such use.

Only those TI components which TI has specifically designated as military grade or "enhanced plastic" are designed and intended for use in military/aerospace applications or environments. Buyer acknowledges and agrees that any military or aerospace use of TI components which have **not** been so designated is solely at the Buyer's risk, and that Buyer is solely responsible for compliance with all legal and regulatory requirements in connection with such use.

TI has specifically designated certain components as meeting ISO/TS16949 requirements, mainly for automotive use. In any case of use of non-designated products, TI will not be responsible for any failure to meet ISO/TS16949.

### Products

Audio	<a href="http://www.ti.com/audio">www.ti.com/audio</a>
Amplifiers	<a href="http://amplifier.ti.com">amplifier.ti.com</a>
Data Converters	<a href="http://dataconverter.ti.com">dataconverter.ti.com</a>
DLP® Products	<a href="http://www.dlp.com">www.dlp.com</a>
DSP	<a href="http://dsp.ti.com">dsp.ti.com</a>
Clocks and Timers	<a href="http://www.ti.com/clocks">www.ti.com/clocks</a>
Interface	<a href="http://interface.ti.com">interface.ti.com</a>
Logic	<a href="http://logic.ti.com">logic.ti.com</a>
Power Mgmt	<a href="http://power.ti.com">power.ti.com</a>
Microcontrollers	<a href="http://microcontroller.ti.com">microcontroller.ti.com</a>
RFID	<a href="http://www.ti-rfid.com">www.ti-rfid.com</a>
OMAP Applications Processors	<a href="http://www.ti.com/omap">www.ti.com/omap</a>
Wireless Connectivity	<a href="http://www.ti.com/wirelessconnectivity">www.ti.com/wirelessconnectivity</a>

### Applications

Automotive and Transportation	<a href="http://www.ti.com/automotive">www.ti.com/automotive</a>
Communications and Telecom	<a href="http://www.ti.com/communications">www.ti.com/communications</a>
Computers and Peripherals	<a href="http://www.ti.com/computers">www.ti.com/computers</a>
Consumer Electronics	<a href="http://www.ti.com/consumer-apps">www.ti.com/consumer-apps</a>
Energy and Lighting	<a href="http://www.ti.com/energy">www.ti.com/energy</a>
Industrial	<a href="http://www.ti.com/industrial">www.ti.com/industrial</a>
Medical	<a href="http://www.ti.com/medical">www.ti.com/medical</a>
Security	<a href="http://www.ti.com/security">www.ti.com/security</a>
Space, Avionics and Defense	<a href="http://www.ti.com/space-avionics-defense">www.ti.com/space-avionics-defense</a>
Video and Imaging	<a href="http://www.ti.com/video">www.ti.com/video</a>

### TI E2E Community

[e2e.ti.com](http://e2e.ti.com)