

# TPA6120A2 High Fidelity Headphone Amplifier

## 1 Features

- SNR of 128dB A-Weighted.
- THD of 112.5dB
- Current-Feedback Architecture
- Output Voltage Noise of  $0.9\mu\text{V}_{\text{rms}}$  at Gain =  $1\text{V/V}$  ( $16\Omega$  Load)
- Power Supply Range:  $\pm 5\text{V}$  to  $\pm 15\text{V}$
- $1300\text{V}/\mu\text{s}$  Slew Rate
- Can be configured for Single Ended or Differential Inputs
- Independent Power Supplies for Low Crosstalk

## 2 Applications

- Professional Audio Equipment
- HiFi Smartphone
- Consumer Home Audio Equipment
- Headphone Drivers

## 3 Description

In applications requiring a high-power output, very high fidelity headphone amplifier, the TPA6120A2 replaces a costly discrete design and allows music, not the amplifier, to be heard. The TPA6120A2's current-feedback AB amplifier architecture delivers high bandwidth, extremely low noise, and up to 128dB of dynamic range.

Three key features make current-feedback amplifiers outstanding for audio. The first feature is the high slew rate that prevents odd order distortion anomalies. The second feature is current-on-demand at the output that enables the amplifier to respond quickly and linearly when necessary without risk of output distortion. When large amounts of output power are suddenly needed, the amplifier can respond extremely quickly without raising the noise floor of the system and degrading the signal-to-noise ratio. The third feature is the gain-independent frequency response that allows the full bandwidth of the amplifier to be used over a wide range of gain settings.

Table 1. Device Information<sup>(1)</sup>

PART NUMBER	PACKAGE	BODY SIZE (NOM)
TPA6120A2	DWP (20)	7.5mm x 12.82mm
	RGY (14)	3.5mm x 3.5mm

(1) For all available packages, see the orderable addendum at the end of the datasheet.

## 4 Simplified Schematic

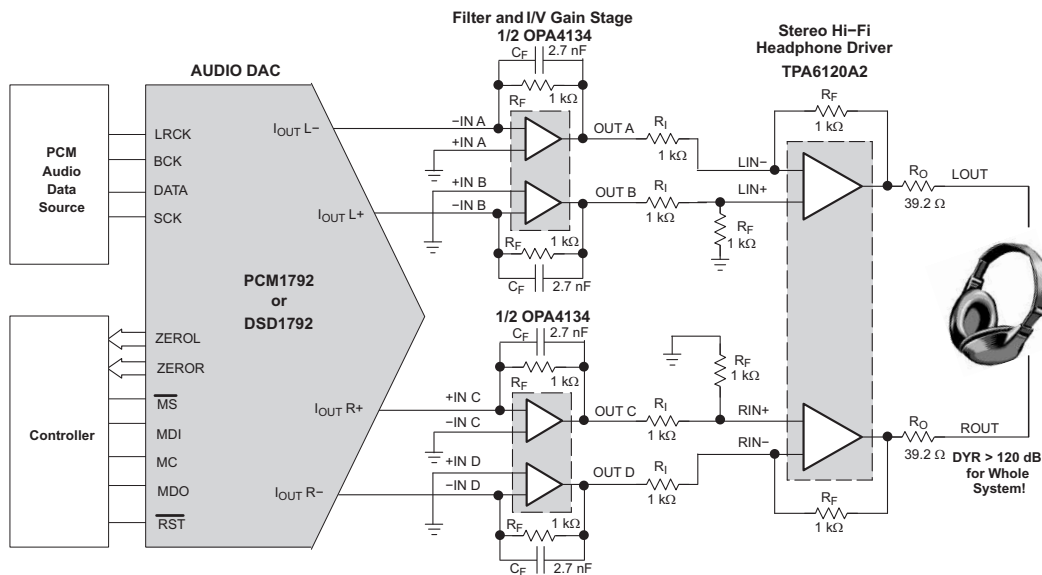

## Table of Contents

<b>1 Features</b> .....	<b>1</b>	9.3 Feature Description .....	<b>8</b>
<b>2 Applications</b> .....	<b>1</b>	9.4 Device Functional Modes .....	<b>9</b>
<b>3 Description</b> .....	<b>1</b>	<b>10 Applications and Implementation</b> .....	<b>9</b>
<b>4 Simplified Schematic</b> .....	<b>1</b>	10.1 High Voltage, High Fidelity DAC + Headphone Amplifier Solution .....	<b>9</b>
<b>5 Revision History</b> .....	<b>2</b>	10.2 High Fidelity Smartphone Application .....	<b>14</b>
<b>6 Pin Configuration and Functions</b> .....	<b>3</b>	<b>11 Power Supply Recommendations</b> .....	<b>16</b>
<b>7 Specifications</b> .....	<b>4</b>	11.1 Independent Power Supplies .....	<b>16</b>
7.1 Absolute Maximum Ratings .....	<b>4</b>	11.2 Power Supply Decoupling .....	<b>16</b>
7.2 Handling Ratings .....	<b>4</b>	<b>12 Layout</b> .....	<b>17</b>
7.3 Thermal Information .....	<b>4</b>	12.1 Layout Guidelines .....	<b>17</b>
7.4 Recommended Operating Conditions .....	<b>4</b>	12.2 Layout Example .....	<b>18</b>
7.5 Electrical Characteristics .....	<b>5</b>	<b>13 Device and Documentation Support</b> .....	<b>20</b>
7.6 Operating Characteristics .....	<b>5</b>	13.1 Documentation Support (if applicable) .....	<b>20</b>
7.7 Typical Characteristics .....	<b>6</b>	13.2 Trademarks .....	<b>20</b>
<b>8 Parameter Measurement Information</b> .....	<b>8</b>	13.3 Electrostatic Discharge Caution .....	<b>20</b>
<b>9 Detailed Description</b> .....	<b>8</b>	13.4 Glossary .....	<b>20</b>
9.1 Overview .....	<b>8</b>	<b>14 Mechanical, Packaging, and Orderable Information</b> .....	<b>21</b>
9.2 Functional Block Diagram .....	<b>8</b>		

## 5 Revision History

NOTE: Page numbers for previous revisions may differ from page numbers in the current version.

<b>Changes from Revision Initial (March 2004) to Revision A</b>	<b>Page</b>
• Changed format of data sheet to new 2014 layout .....	<b>1</b>
• Added VQFN package information .....	<b>1</b>
• Updated Pin descriptions to clarify power supply. ....	<b>3</b>
• Lowered minimum $V_{IC}(\pm 5V_{CC})$ from $\pm 3.6$ to $\pm 3.4$ .....	<b>5</b>
• Lowered minimum $V_{IC}(\pm 15V_{CC})$ from $\pm 13.4V$ to $\pm 13.2V$ .....	<b>5</b>
• Deleted IMD (Intermodulation Distortion), $\pm 12V_{CC}$ data, Dynamic Range (replaced with SNR, in 1V/V gain) .....	<b>5</b>
• Converted from % to dB .....	<b>5</b>
• Updated with latest data from newer QFN based EVM. ....	<b>5</b>

## 6 Pin Configuration and Functions

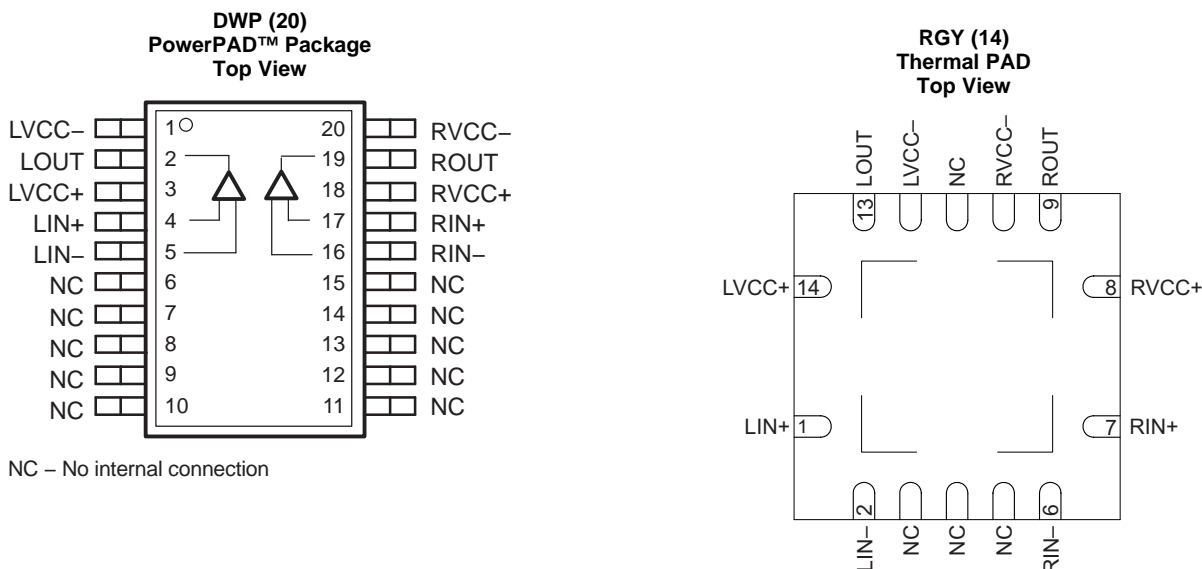
**Table 2. Pin Functions**

PIN		QFN NO.	I/O	DESCRIPTIONS
NAME	DWP NO.			
LVCC-	1	12	I	Left channel negative power supply – must be kept at the same potential as RVCC- if both amplifiers are to be used.
LOUT	2	13	O	Left channel output
LVCC+	3	14	I	Left channel positive power supply – must be kept at the same potential as RVCC+ if both amplifiers are to be used.
LIN+	4	1	I	Left channel positive input
LIN-	5	2	I	Left channel negative input
NC	6,7,8,9,10,11,12,13,14,15	3, 4, 5, 11	-	Not internally connected
RIN-	16	6	I	Right channel negative input
RIN+	17	7	I	Right channel positive input
RVCC+	18	8	I	Right channel positive power supply - must be kept at the same potential as LVCC+ if both amplifiers are to be used.
ROUT	19	9	O	Right channel output
RVCC-	20	10	I	Right channel negative power supply - must be kept at the same potential as LVCC- if both amplifiers are to be used.
Thermal Pad	-	-	-	Connect to ground. The thermal pad must be soldered down in all applications to properly secure device on the PCB.

## 7 Specifications

### 7.1 Absolute Maximum Ratings

over operating free-air temperature range (unless otherwise noted) <sup>(1)</sup>

	MIN	MAX	UNIT
Supply voltage, $xV_{CC+}$ to $xV_{CC-}$ . Where x=L or R channel	9	33	V
Input voltage, $V_I$ <sup>(2)</sup>		$\pm V_{CC}$	
Differential input voltage, $V_{ID}$		6	V
Minimum load impedance		8	$\Omega$
Continuous total power dissipation	See the <a href="#">Thermal Information</a> table		
Operating free-air temperature range, $T_A$	-40	85	°C
Operating junction temperature range, $T_J$ <sup>(3)</sup>	-40	150	°C

- Stresses beyond those listed under “absolute maximum ratings” may cause permanent damage to the device. These are stress ratings only, and functional operation of the device at these or any other conditions beyond those indicated under “recommended operating conditions” is not implied. Exposure to absolute-maximum-rated conditions for extended periods may affect device reliability.
- When the TPA6120A2 is powered down, the input source voltage must be kept below 600mV peak.
- The TPA6120A2 incorporates an exposed PowerPAD on the underside of the chip. This acts as a heatsink and must be connected to a thermally dissipating plane for proper power dissipation. Failure to do so may result in exceeding the maximum junction temperature that could permanently damage the device. See TI Technical Brief SLMA002 for more information about utilizing the PowerPAD thermally enhanced package.

### 7.2 Handling Ratings

		MIN	MAX	UNIT	
$T_{stg}$	Storage Temperature	-40	125	°C	
$V_{(ESD)}$	Electrostatic Discharge	Human body model (HBM), per ANSI/ESDA/JEDEC JS-001, LVCC+, RVCC+, LVCC-, RVCC- pins <sup>(1)</sup>	-500	500	V
		Human body model (HBM), per ANSI/ESDA/JEDEC JS-001, all other pins	-2000	2000	V
		Charged device model (CDM), per JEDEC specification JESD22-C101, all pins	-1500	1500	V

- Level listed above is the passing level per ANSI, ESDA, and JEDEC JS-001. JEDEC document JEP155 states that 500V HBM allows safe manufacturing with a standard ESD control process.

### 7.3 Thermal Information

THERMAL METRIC <sup>(1)</sup>		TPA6120A2	TPA6120A2	UNITS
		DWP	RGY	
		20 PINS	14 PINS	
$R_{\theta JA}$	Junction-to-ambient thermal resistance	44.5	49.4	°C/W
$R_{\theta Jctop}$	Junction-to-case (top) thermal resistance	55.2	62.0	
$R_{\theta JB}$	Junction-to-board thermal resistance	36.1	25.4	
$\Psi_{JT}$	Junction-to-top characterization parameter	23.1	1.6	
$\Psi_{JB}$	Junction-to-board characterization parameter	36.2	25.5	
$R_{\theta Jcbot}$	Junction-to-case (bottom) thermal resistance	7.6	6.2	

- For more information about traditional and new thermal metrics, see the *IC Package Thermal Metrics* application report, [SPRA953](#).

### 7.4 Recommended Operating Conditions

		MIN	NOM	MAX	UNIT
Supply voltage, $V_{CC+}$ and $V_{CC-}$	Split Supply	$\pm 5$		$\pm 15$	V
	Single Supply	10		30	
Load impedance	$V_{CC} = \pm 5V$ or $\pm 15V$	16			$\Omega$
Operating free-air temperature, $T_A$		-40		85	°C

## 7.5 Electrical Characteristics

over operating free-air temperature range (unless otherwise noted)

PARAMETER		TEST CONDITIONS	MIN	TYP	MAX	UNIT
V <sub>IO</sub>	Input offset voltage (measured differentially)	V <sub>CC</sub> = ±5V or ±15V		2	5	mV
PSRR	Power supply rejection ratio	V <sub>CC</sub> = ±5V to ±15V		75		dB
V <sub>IC</sub>	Common mode input voltage	V <sub>CC</sub> = ±5V	±3.4	±3.7		V
		V <sub>CC</sub> = ±15V	±13.2	±13.5		
I <sub>CC</sub>	Supply current (each channel)	V <sub>CC</sub> = ±5V		11.5	13	mA
		V <sub>CC</sub> = ±15V			15	
I <sub>O</sub>	Output current (per channel)	V <sub>CC</sub> = ±5V to ±15V		700		mA
	Input offset voltage drift	V <sub>CC</sub> = ±5V or ±15V		20		μV/°C
r <sub>i</sub>	Input resistance			300		kΩ
r <sub>o</sub>	Output resistance	Open Loop		13		Ω
V <sub>O</sub>	Output voltage swing	V <sub>CC</sub> = ±15V, R <sub>L</sub> = 25Ω	11.8 to -11.5	12.5 to -12.2		V

## 7.6 Operating Characteristics<sup>(1)</sup>

T<sub>A</sub> = 25°C, R<sub>L</sub> = 25Ω, Gain = 1V/V (unless otherwise noted)

PARAMETER		TEST CONDITIONS		MIN	TYP	MAX	UNIT
THD+N	Total harmonic distortion plus noise	R <sub>L</sub> = 32Ω f = 1kHz	V <sub>CC</sub> = ±5V P <sub>O</sub> = 10mW		101		dB
			V <sub>CC</sub> = ±15V P <sub>O</sub> = 100mW		90		
		R <sub>L</sub> = 64Ω f = 1kHz	V <sub>CC</sub> = ±5V P <sub>O</sub> = 10mW		104		
			V <sub>CC</sub> = ±15V P <sub>O</sub> = 100mW		94		
		V <sub>CC</sub> = ±5V, Gain = 1V/V	V <sub>O</sub> = 3V <sub>PP</sub> , R <sub>L</sub> = 10kΩ f = 1kHz		104		
V <sub>CC</sub> = ±15V, Gain = 1V/V	V <sub>O</sub> = 10V <sub>PP</sub> , R <sub>L</sub> = 10kΩ f = 1kHz		108				
k <sub>SVR</sub>	Supply voltage rejection ratio	R <sub>L</sub> = 32Ω f = 1kHz V <sub>(RIPPLE)</sub> = 1V <sub>PP</sub>	V <sub>CC</sub> = ±5V		-75		dB
			V <sub>CC</sub> = ±15V		-78		
		R <sub>L</sub> = 64Ω f = 1kHz V <sub>(RIPPLE)</sub> = 1V <sub>PP</sub>	V <sub>CC</sub> = ±5V		-75		
			V <sub>CC</sub> = ±15V		-75		
CMRR	Common mode rejection ratio (differential)	V <sub>CC</sub> = ±5V or ±15V		100		dB	
SR	Slew rate	V <sub>CC</sub> = ±15V, Gain = 5V/V, V <sub>O</sub> = 20 V <sub>PP</sub>		1300		V/μs	
		V <sub>CC</sub> = ±5V, Gain = 2V/V, V <sub>O</sub> = 5V <sub>PP</sub>		900			
V <sub>n</sub>	Output noise voltage	V <sub>CC</sub> = ±5V to ±15V R <sub>L</sub> = 16Ω	Gain = 1V/V		0.9	μVrms	
SNR	Signal-to-noise ratio	R <sub>L</sub> = 32Ω to 64Ω f = 1kHz	V <sub>CC</sub> = ±15V, Gain = 1V/V. A Weighted		128		dB
			V <sub>CC</sub> = ±5V, Gain = 1V/V. A Weighted		116		
Crosstalk	Crosstalk	V <sub>I</sub> = 1V <sub>RMS</sub> R <sub>F</sub> = 1kΩ R <sub>L</sub> = 32Ω to 64Ω f = 1kHz	V <sub>CC</sub> = ±15V		-112		dB
			V <sub>CC</sub> = ±5V		-105		

(1) For THD+N, k<sub>SVR</sub>, and crosstalk, the bandwidth of the measurement instruments was set to 80kHz.

## 7.7 Typical Characteristics

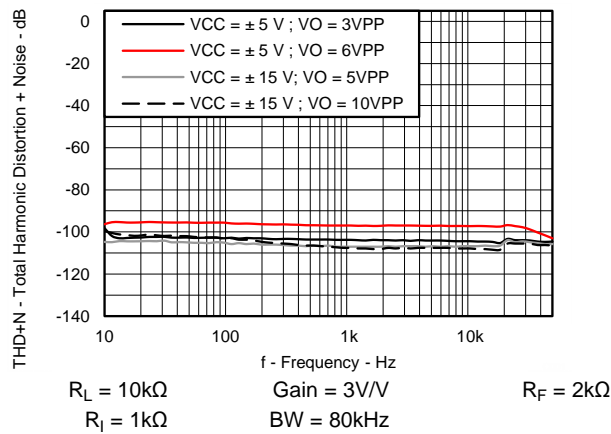

Figure 1. Total Harmonic Distortion + Noise versus Frequency

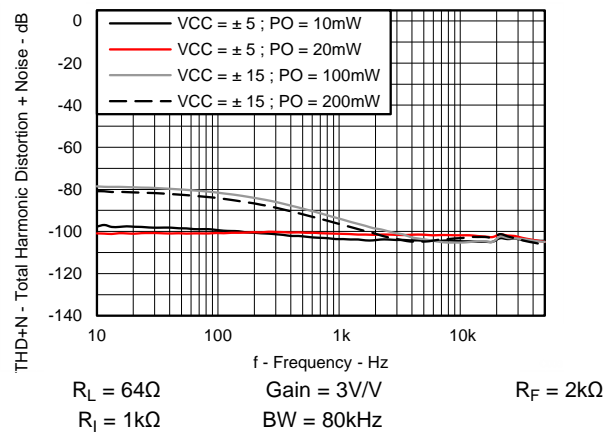

Figure 2. Total Harmonic Distortion + Noise versus Frequency

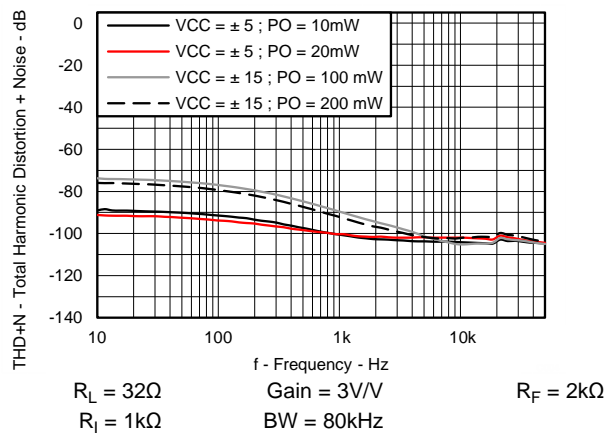

Figure 3. Total Harmonic Distortion + Noise versus Frequency

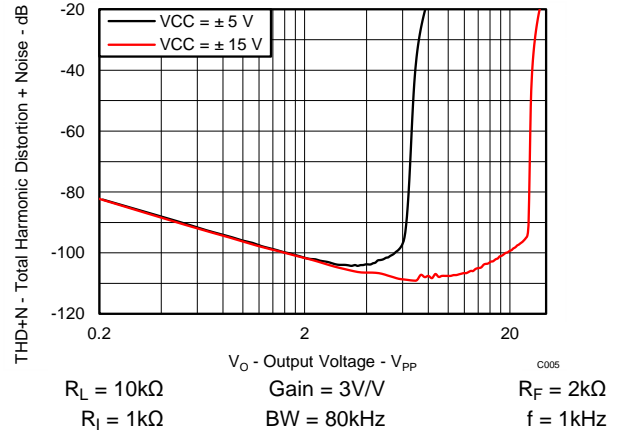

Figure 4. Total Harmonic Distortion + Noise versus Output Voltage

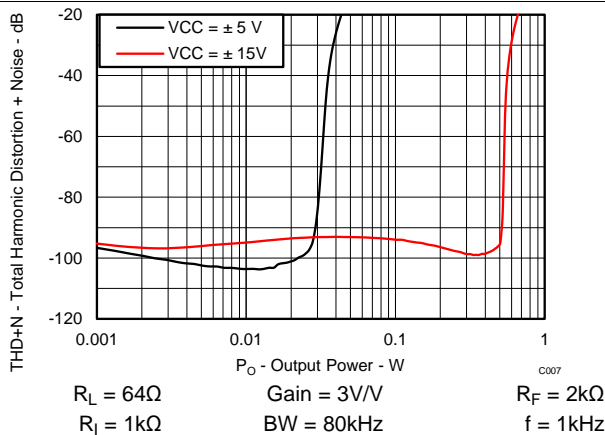

Figure 5. Total Harmonic Distortion + Noise versus Output Power

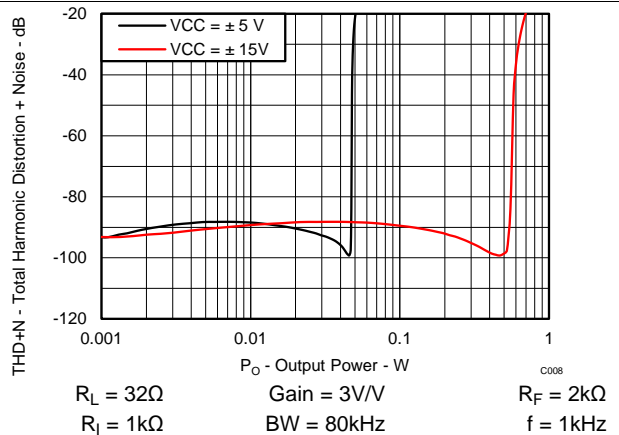

Figure 6. Total Harmonic distortion + Noise versus Output Power

Typical Characteristics (continued)

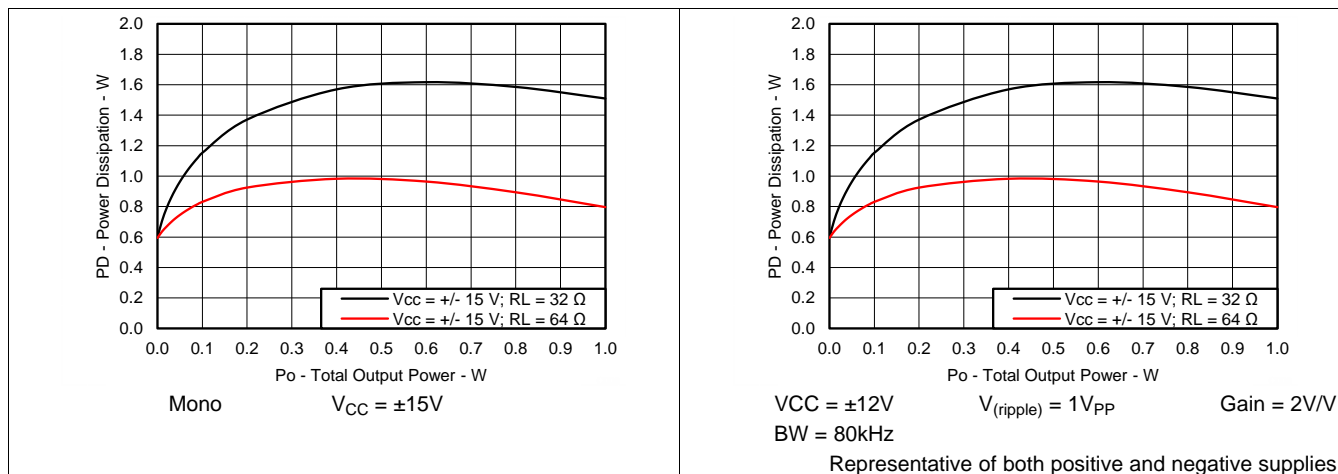

Figure 7. Power Dissipation versus Output Power

Figure 8. Power Dissipation versus Total Output Power

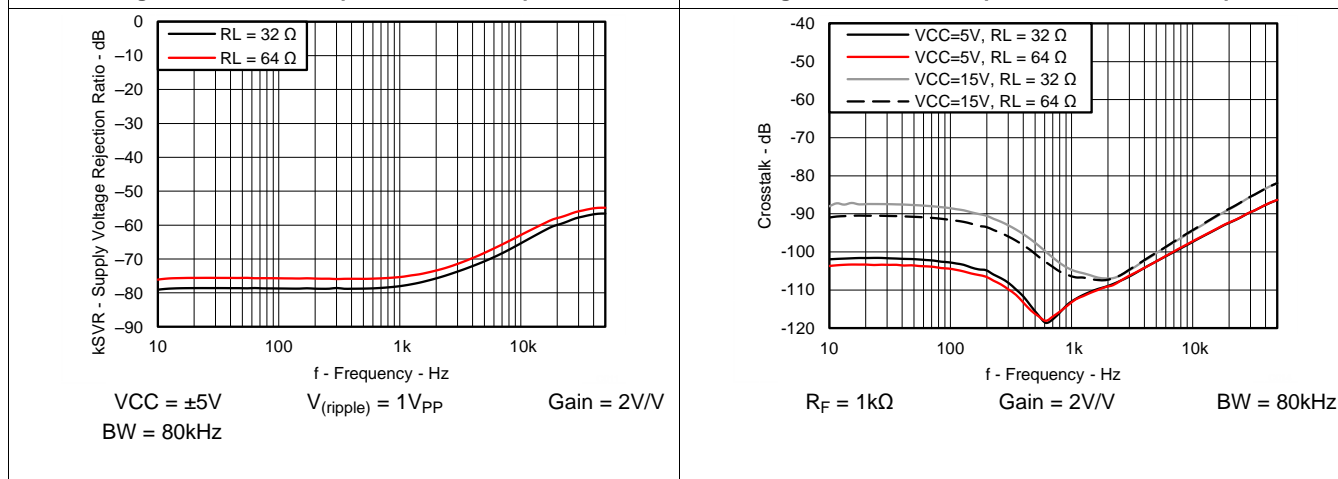

Figure 9. Supply Voltage rejection Ratio versus Frequency

Figure 10. Crosstalk versus Frequency

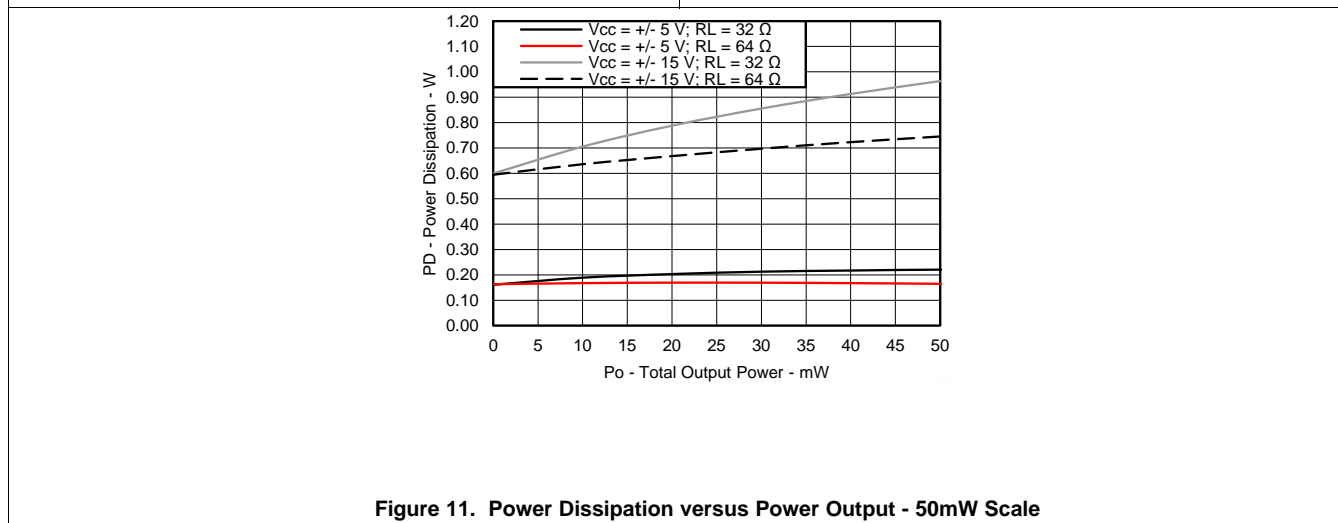
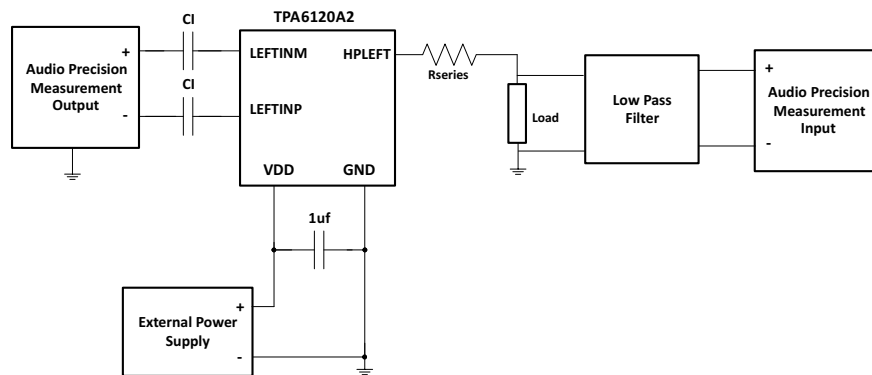

Figure 11. Power Dissipation versus Power Output - 50mW Scale

## 8 Parameter Measurement Information



- A. Separate power supply decoupling capacitors are used on all Vcc pins.
- B. The low-pass filter is used to remove harmonic content above the audible range.

**Figure 12. Test Circuit**

## 9 Detailed Description

### 9.1 Overview

The TPA6120A2 is a current-feedback amplifier with differential inputs and single-ended outputs.

### 9.2 Functional Block Diagram

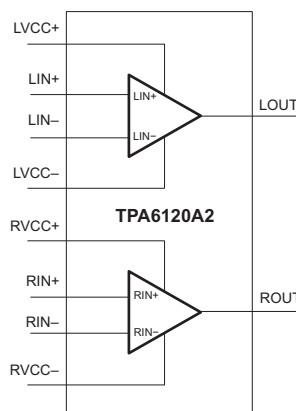

**Figure 13. TPA6120A2 Block Diagram**

### 9.3 Feature Description

#### 9.3.1 Current-Feedback Amplifier

Current feedback results in low voltage noise, low distortion, high open-loop gain throughout a large frequency range, and can be used in a similar fashion as voltage-feedback amplifiers. The low distortion of the TPA6120A2 results in a signal-to-noise ratio of 128dB.

#### 9.3.2 Independent Power Supplies

Because the power supplies for the two amplifiers are available separately, one amplifier can be turned off to conserve power.

See [Power Supply Recommendations](#)

## 9.4 Device Functional Modes

This device operates as a wide-bandwidth, current-feedback amplifier.

## 10 Applications and Implementation

### 10.1 High Voltage, High Fidelity DAC + Headphone Amplifier Solution

#### 10.1.1 Application Circuit

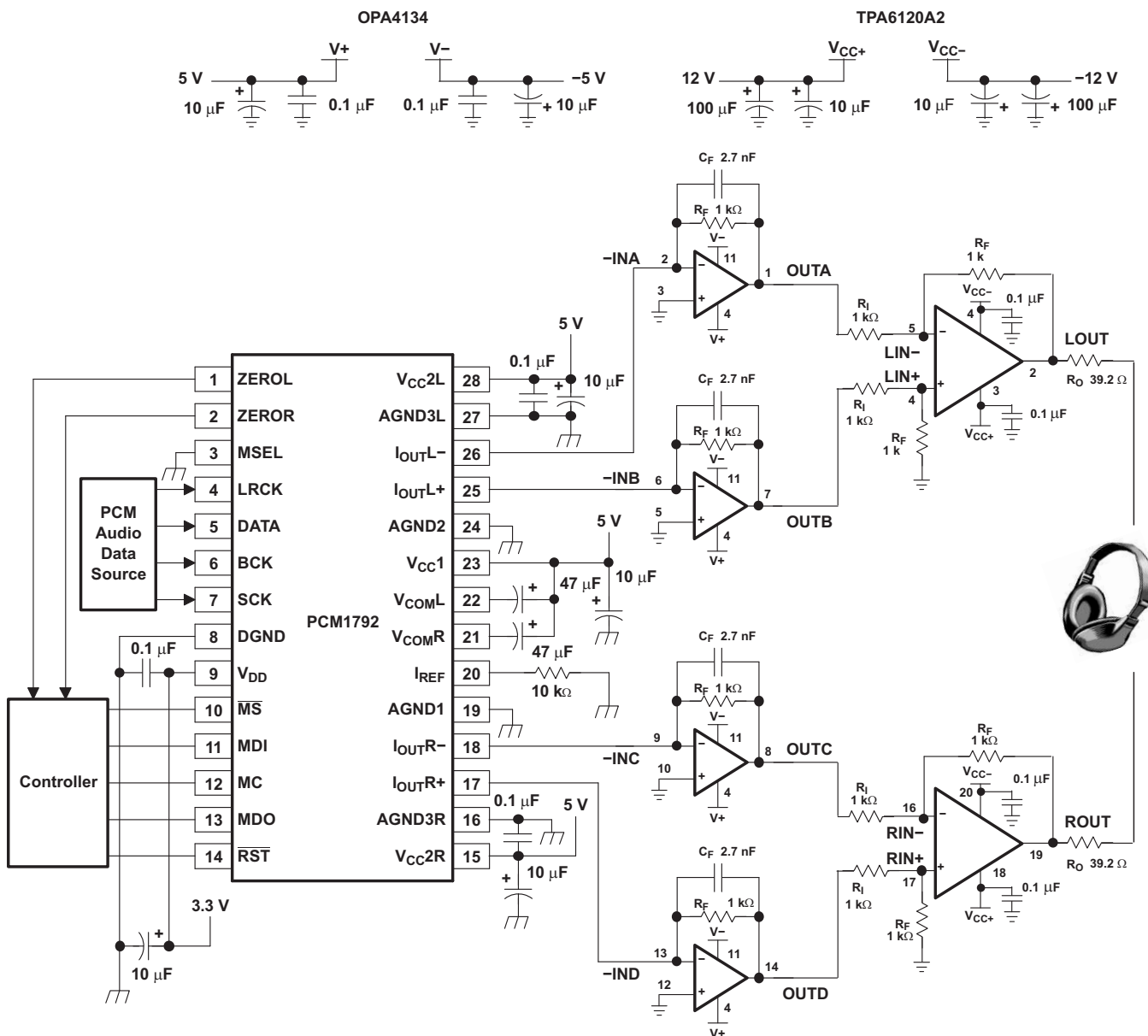

Figure 14. Typical Application Circuit

#### 10.1.1.1 Design Requirements

In many applications, the audio source is digital, and must go through a digital-to-analog converter (DAC) so that traditional analog amplifiers can drive the speakers or headphones.

Figure 14 shows a complete circuit schematic for such a system. The digital audio is fed into a high performance DAC. The PCM1792, a Burr-Brown product from TI, is a 24-bit, stereo DAC.

## High Voltage, High Fidelity DAC + Headphone Amplifier Solution (continued)

### 10.1.1.2 Detailed Design Procedure

The output of the PCM1792 is current, not voltage, so the OPA4134 is used to convert the current input to a voltage output. The OPA4134, a Burr-Brown product from TI, is a low-noise, high-speed, high-performance operational amplifier.  $C_F$  and  $R_F$  are used to set the cutoff frequency of the filter. The RC combination in [Figure 14](#) has a cutoff frequency of 59 kHz. All four amplifiers of the OPA4134 are used so the TPA6120A2 can be driven differentially.

The output of the OPA4134 goes into the TPA6120A2. The TPA6120A2 is configured for use with differential inputs, stereo use, and a gain of 2V/V. Note that the 0.1 $\mu$ F capacitors are placed at every supply pin of the TPA6120A2, as well as the 39.2 $\Omega$  series output resistor.

Each output goes to one channel of a pair of stereo headphones, where the listener enjoys crisp, clean, virtually noise free music with a dynamic range greater than the human ear is capable of detecting.

#### 10.1.1.2.1 Resistor Values

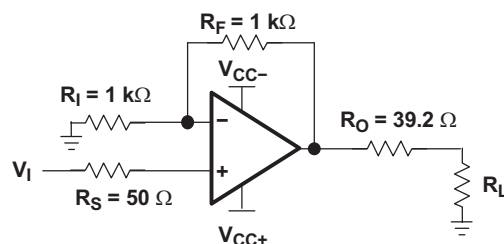

**Figure 15. Single-Ended Input With A Noninverting Gain Of 2V/V**

In the most basic configuration (see [Figure 15](#)), four resistors must be considered, not including the load impedance. The feedback and input resistors,  $R_F$  and  $R_I$ , respectively, determine the closed-loop gain of the amplifier.  $R_O$  is a series output resistor designed to protect the amplifier from any capacitance on the output path, including board and load capacitance.  $R_S$  is a series input resistor.

The series output resistor should be between 10 $\Omega$  and 100 $\Omega$ . The output series resistance eases the work of the output power stage by increasing the load when low impedance headphones are connected, as well as isolating any capacitance on the following traces and headphone cable.

Because the TPA6120A2 is a current-feedback amplifier, take care when choosing the feedback resistor. TI recommends a lower level of 800 $\Omega$  for the feedback resistance. No capacitors should be used in the feedback path, as they will form a short circuit at high frequencies.

The value of the feedback resistor should be chosen by using [Figure 18](#) as a guideline. The gain can then be set by adjusting the input resistor. The smaller the feedback resistor, the less noise is introduced into the system. However, smaller values move the dominant pole to higher and higher frequencies, making the device more susceptible to oscillations. Higher feedback resistor values add more noise to the system, but pull the dominant pole down to lower frequencies, making the device more stable. Higher impedance loads tend to make the device more unstable. One way to combat this problem is to increase the value of the feedback resistor. It is not recommended that the feedback resistor exceed a value of 10k $\Omega$ . The typical value for the feedback resistor for the TPA6120A2 is 1k $\Omega$ . In some cases, where a high-impedance load is used along with a relatively large gain and a capacitive load, it may be necessary to increase the value of the feedback resistor from 1k $\Omega$  to 2k $\Omega$ , thus adding more stability to the system. Another method to deal with oscillations is to increase the size of  $R_O$ .

#### CAUTION

Do not place a capacitor in the feedback path. Doing so can cause oscillations.

Capacitance at the outputs can cause oscillations. Capacitance from some sources, such as layout, can be minimized. Other sources, such as those from the load (for example, the inherent capacitance in a pair of headphones), cannot be easily minimized. In this case, adjustments to  $R_O$  and/or  $R_F$  may be necessary.

## High Voltage, High Fidelity DAC + Headphone Amplifier Solution (continued)

The series output resistor should be kept at a minimum of 10Ω; small enough so that the effect on the load is minimal, but large enough to provide the protection necessary such that the output of the amplifier sees little capacitance. The value can be increased to provide further isolation, up to 100Ω. Care should be taken in selecting the thermal capacity of the output series resistor, as it will create a potential divider with the load and dissipate power.

The series resistor,  $R_S$ , should be used for two reasons:

1. It prevents the positive input pin from being exposed to capacitance from the line and source.
2. It prevents the source from seeing the input capacitance of the TPA6120A2.

The 50Ω resistor was chosen because it provides ample protection without interfering in any noticeable way with the signal. Not shown is another 50Ω resistor that can be placed on the source side of  $R_S$  to ground. In that capacity, it serves as an impedance match to any 50Ω source. See [Figure 15](#)

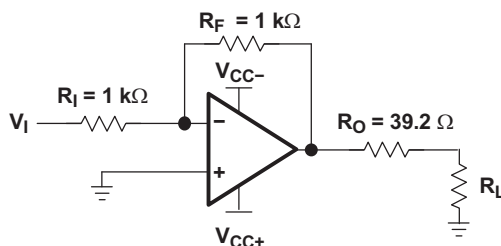

Figure 16. Single-Ended Input With A Noninverting Gain Of  $-1V/V$

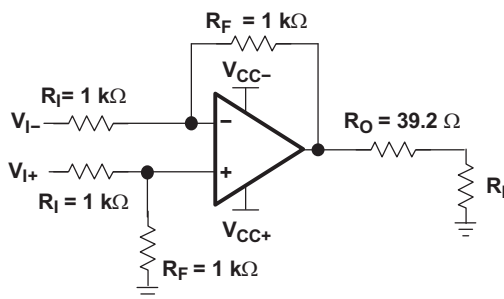

Figure 17. Differential Input With A Noninverting Gain Of  $2V/V$

[Figure 17](#) shows the TPA6120A2 connected with differential inputs. Differential inputs are useful because they take the greatest advantage of the high CMRR of the device. The two feedback resistor values must be kept the same, as do the input resistor values.

## High Voltage, High Fidelity DAC + Headphone Amplifier Solution (continued)

Special note regarding mono operation:

- If both amplifiers are powered on, but only one channel is to be used, the unused amplifier **MUST** have a feedback resistor from the output to the negative input. Additionally, the positive input should be grounded as close to the pin as possible. Terminate the output as close to the output pin as possible with a 25Ω load to ground.
- These measures should be followed to prevent the unused amplifier from oscillating. If it oscillates, and the power pins of both amplifiers are tied together, the performance of the amplifier could be seriously degraded.

### 10.1.1.2.2 Checking For Oscillations And Instability

Checking the stability of the amplifier setup is recommended. High frequency oscillations in the megahertz region can cause undesirable effects in the audio band.

Sometimes, the oscillations can be quite clear. An unexpectedly large draw from the power supply may be an indication of oscillations. These oscillations can be seen with an oscilloscope. However, if the oscillations are not obvious, or there is a chance that the system is stable but close to the edge, placing a scope probe with 10pF of capacitance can make the oscillations worse, or actually cause them to start.

A network analyzer can be used to determine the inherent stability of a system. An output versus frequency curve generated by a network analyzer can be a good indicator of stability. At high frequencies, the curve shows whether a system is oscillating, close to oscillation, or stable. In [Figure 18](#) the system is stable because the high frequency rolloff is smooth and has no peaking. Increasing  $R_F$  decreases the frequency at which this rolloff occurs (see the Resistor Values section). Another scenario shows some peaking at high frequency. If the peaking is 2dB, the amplifier is stable as there is still 45 degrees of phase margin. As the peaking increases, the phase margin shrinks, causing the amplifier and the system to approach instability. The same system that normally has a 2dB peak has an increased peak when a capacitor is added to the output, indicating that the system is either on the verge of oscillation or is oscillating; corrective action is required.

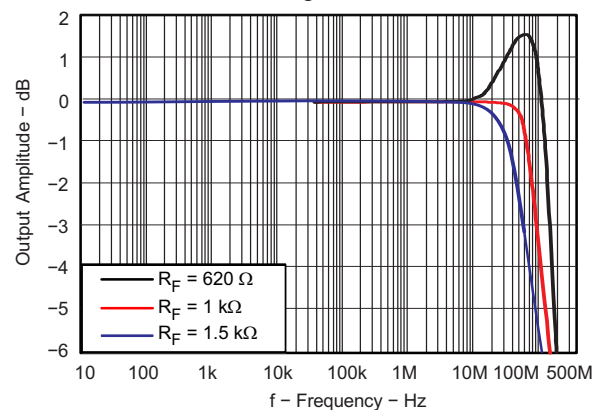

$$V_{CC} = \pm 5V$$

$$\text{Gain} = 1V/V$$

$$R_L = 25\Omega$$

$$V_{IN} = 200mV$$

**Figure 18. High Frequency Peaking for Oscillation and Instability**

## High Voltage, High Fidelity DAC + Headphone Amplifier Solution (continued)

### 10.1.1.2.3 Thermal Considerations

There is no one to one relationship between output power and heat dissipation, so the following equations must be used:

$$\text{Efficiency of an amplifier} = \frac{P_L}{P_{SUP}} \quad (1)$$

Where

$$P_L = \frac{V_{LRMS}^2}{R_L}, \text{ and } V_{LRMS} = \frac{V_P}{\sqrt{2}}, \text{ therefore, } P_L = \frac{V_P^2}{2R_L} \text{ per channel} \quad (2)$$

$$P_{SUP} = V_{CC} I_{CCavg} + V_{CC} I_{CC(q)} \quad (3)$$

$$I_{CCavg} = \frac{1}{\pi} \int_0^{\frac{\pi}{2}} \frac{V_P}{R_L} \sin(t) dt = -\frac{V_P}{\pi R_L} [\cos(t)]_0^{\frac{\pi}{2}} = \frac{V_P}{\pi R_L} \quad (4)$$

Where

$$V_P = \sqrt{2 P_L R_L} \quad (5)$$

Therefore,

$$P_{SUP} = \frac{V_{CC} V_P}{\pi R_L} + V_{CC} I_{CC(q)} \quad (6)$$

$P_L$  = Power delivered to load (per channel)

$P_{SUP}$  = Power drawn from power supply

$V_{LRMS}$  = RMS voltage on the load

$R_L$  = Load resistance

$V_P$  = Peak voltage on the load

$I_{CCavg}$  = Average current drawn from the power supply

$I_{CC(q)}$  = Quiescent current (per channel)

$V_{CC}$  = Power supply voltage (total supply voltage = 30 V if running on a ±15-V power supply)

$\eta$  = Efficiency of a SE amplifier

For stereo operation, the efficiency does not change because both  $P_L$  and  $P_{SUP}$  are doubled, affecting the amount of power dissipated by the package in the form of heat.

A simple formula for calculating the power dissipated,  $P_{DISS}$ , is shown in [Equation 7](#):

$$P_{DISS} = (1 - \eta) P_{SUP} \quad (7)$$

In stereo operation,  $P_{SUP}$  is twice the quantity that is present in mono operation.

The maximum ambient temperature,  $T_A$ , depends on the heat-sinking ability of the system.  $R_{\theta JA}$  for a 20-pin DWP, whose thermal pad is properly soldered down, is shown in [Thermal Information](#). Also see [Figure 19](#).

$$T_{A \text{ Max}} = T_{J \text{ Max}} - \Theta_{JA} P_{DISS} \quad (8)$$

### 10.1.2 Application Performance Plots

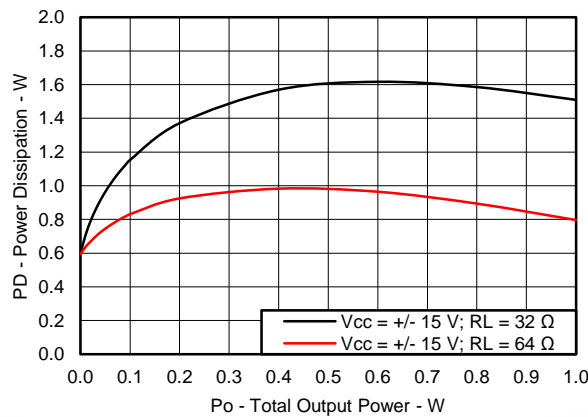

Figure 19. Power Dissipation versus Output Power

## 10.2 High Fidelity Smartphone Application

### 10.2.1 Application Circuit

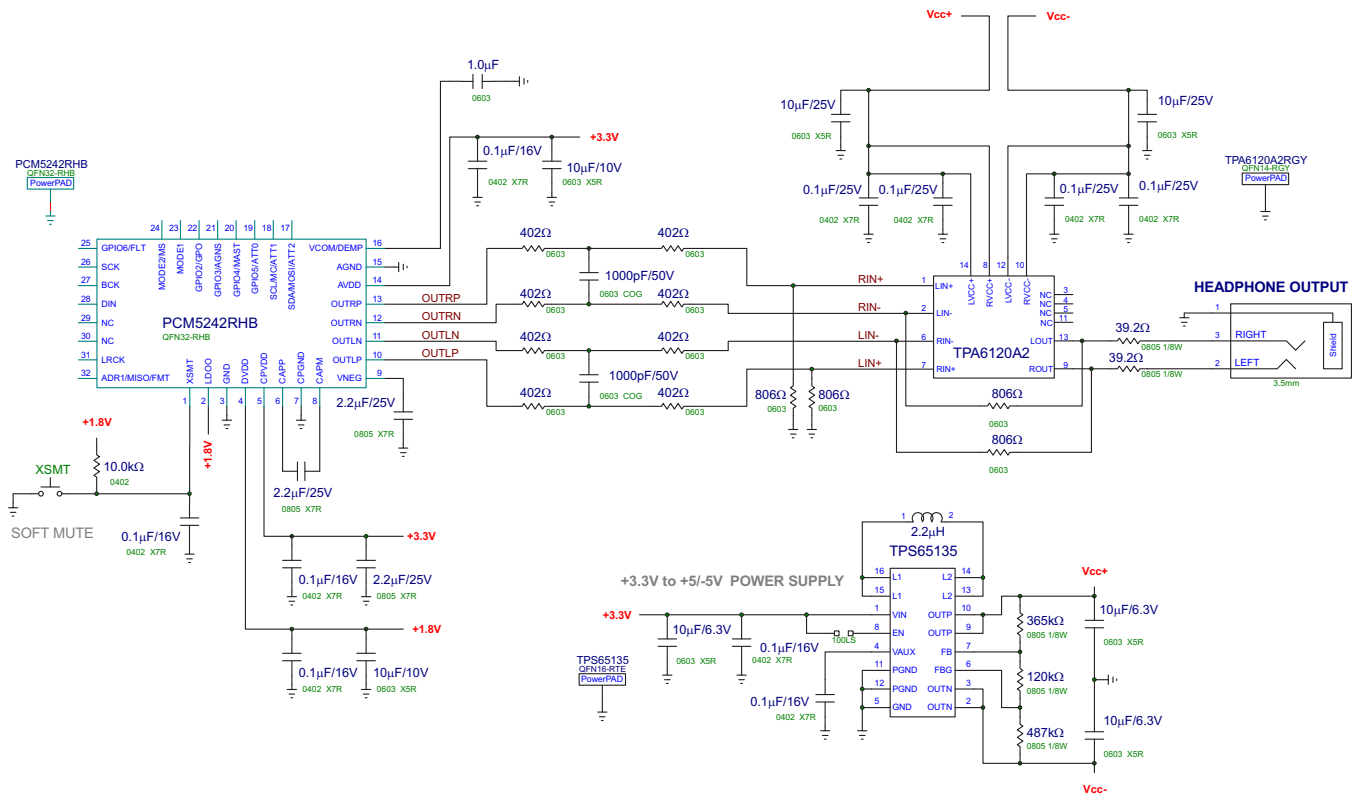

Figure 20. Typical Application Circuit

A new trend in portable applications are termed "Hifi Smartphones". In these systems, a standard portable audio codec continues to be used for telephony, while a separate, higher performance DAC and Headphone Amplifier is used for music playback.

Figure 20 shows a complete circuit schematic for such a system. The digital audio is fed into a high performance DAC. The PCM5242, a Burr-Brown product from TI, is a 32-bit, stereo DAC.

### 10.2.2 Design Requirements

- $\pm 5V$  Operation from an over system power supply of 3.3V

## High Fidelity Smartphone Application (continued)

- Stereo differential inputs (DAC is differential)
- Be transparent to the user. (DAC SNR and THD+N performance all the way to the headphone)

### 10.2.3 Design Procedure

For optimal performance, the TPA6120A2 is configured for use with differential inputs, stereo use, and a gain of 1V/V.

The TPA6120A2 requires a bipolar power supply to drive a ground centered output. The application employs a TPS65135 DC-DC converter that generates  $\pm 5V$  from a single 3.3V supply.

The PCM5242 DAC is configured for a 1VRMS output so that clipping is avoided should the 3.3V power supply sag. The PCM5242 offers a ground centered output, so that no DC blocking capacitors are required between it and the TPA6120A2.

Resistor values around the TPA6120A2 of 806 $\Omega$  and a 39.2 $\Omega$  were found to offer the optimal conditions of SNR and THD. Starting with 1K $\Omega$  resistors for input and feedback, and 10 $\Omega$  output resistance, the feedback resistance was lowered to increase the amount of current in the feedback network. The output resistance was increased to ease the load on the headphone amplifier when low impedance headphones are connected. Both of these additions contribute to the excellent SNR and THD of the TPA6120A2 in such a low voltage application.

Note that the 0.1- $\mu F$  X7R capacitors are placed at every supply pin of the TPA6120A2.

Using such a solution makes the TPA6120A2 transparent in the circuit, even into a low impedance 32 $\Omega$  load.

The remaining steps are the same as those described in [Resistor Values](#).

### 10.2.4 Application Performance Plots

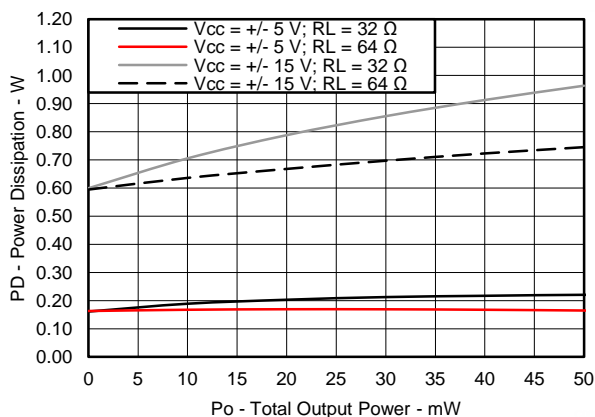

Figure 21. Power Dissipation versus Power Output - 50mW Scale

In this particular application, the TPA6120A2's performance is transparent and the performance of the system is dictated by the PCM5242 DAC.

## 11 Power Supply Recommendations

### 11.1 Independent Power Supplies

The TPA6120A2 consists of two independent high-fidelity amplifiers. Each amplifier has its own voltage supply, allowing the user to leave one of the amplifiers off, saving power, reducing the generated heat, and reducing crosstalk.

Although the power supplies are independent, there are some limitations. When both amplifiers are used, the same voltage must be applied to each amplifier. For example, if the left channel amplifier is connected to a  $\pm 12$ -V supply, the right channel amplifier must also be connected to a  $\pm 12$ -V supply. If the device is connected to a different supply voltage, it may not operate properly and consistently.

When the use of only one amplifier is preferred, it must be the left amplifier. The voltage supply to the left amplifier is also responsible for internal start-up and bias circuitry of the device. Regardless of whether one or both amplifiers are used, the  $V_{CC-}$  pins of both amplifiers must always be at the same potential.

To power down the right channel amplifier, disconnect the  $V_{CC+}$  pin from the power source.

The two independent power supplies can be tied together on the board to receive their power from the same source.

### 11.2 Power Supply Decoupling

As with any design, proper power supply decoupling is essential. Decoupling prevents noise from entering the device via the power traces and provides the extra power the device can sometimes require in a rapid fashion, preventing the device from being momentarily current-starved. Both of these functions serve to reduce distortion, leaving a clean, uninterrupted signal at the output.

Bulk decoupling capacitors should be used where the main power is brought to the board. Smaller capacitors should be placed as close as possible to the actual power pins of the device. Because the TPA6120A2 has four power pins, use four surface mount capacitors. Both types of capacitors should be low ESR.

## 12 Layout

### 12.1 Layout Guidelines

Proper board layout is crucial to getting the maximum performance out of the TPA6120A2.

A ground plane should be used on the board to provide a low inductive ground connection. Having a ground plane underneath traces adds capacitance, so care must be taken when laying out the ground plane on the underside of the board (assuming a 2-layer board). The ground plane is necessary on the bottom for thermal reasons.

Stray capacitance can still make its way onto the sensitive outputs and inputs. Place components as close as possible to the pins and reduce trace lengths. See [Figure 22](#) and [Figure 23](#). Place the feedback resistor and the series output resistor extremely close to the pins. The input resistor should also be placed close to the pin. If the amplifier is to be driven in a noninverting configuration, ground the input close to the device so the current has a short, straight path to the PowerPAD (gnd).

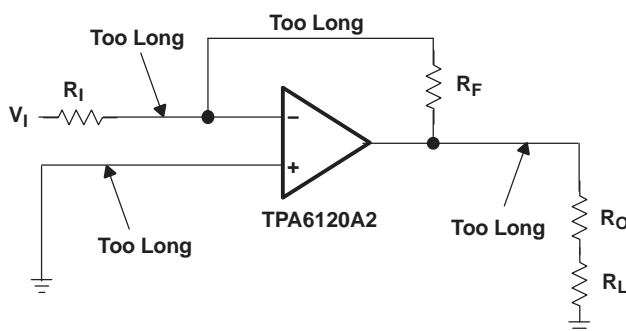

Figure 22. Layout That Can Cause Oscillation

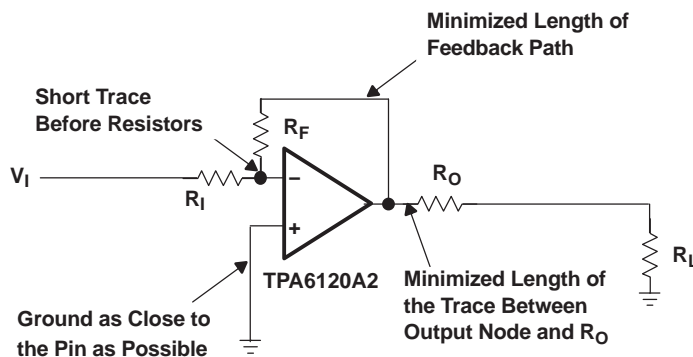

Figure 23. Layout Designed To Reduce Capacitance On Critical Nodes

## 12.2 Layout Example

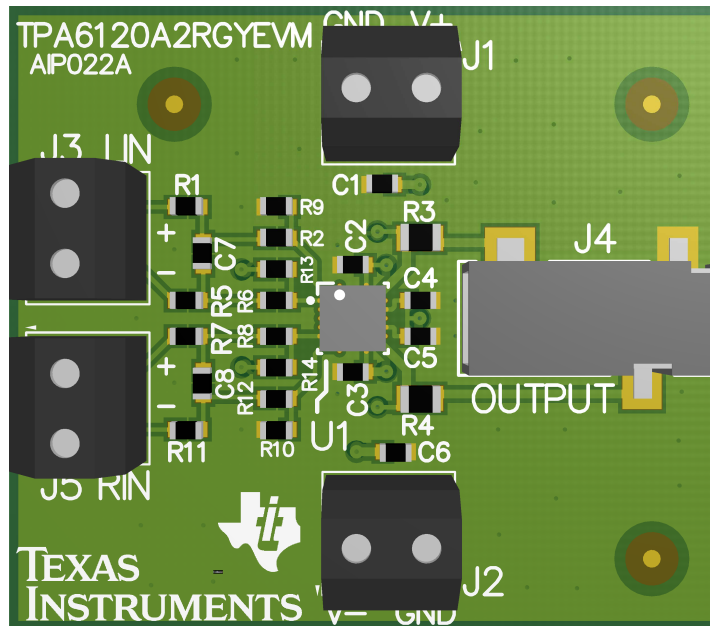

Figure 24. PCB Layout Example

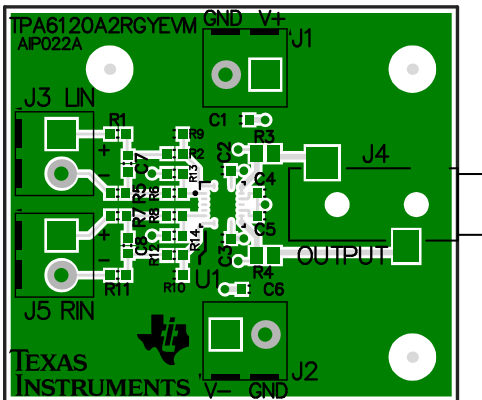

Figure 25. Example PCB Layout, Top Layer and Silkscreen, Top View

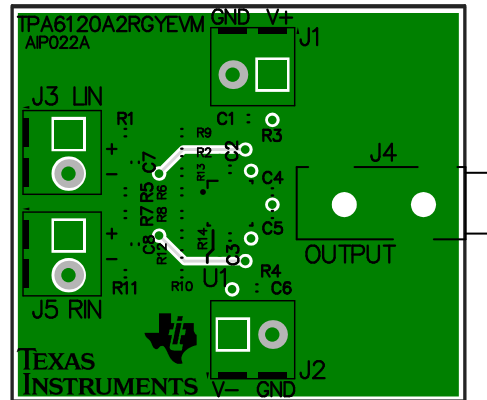

Figure 26. Example PCB Layout, Middle-1 Layer and Silkscreen, Top View

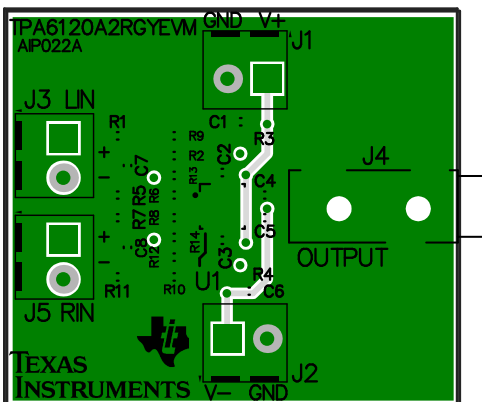

Figure 27. Example PCB Layout, Middle-2 Layer and Silkscreen, Top View

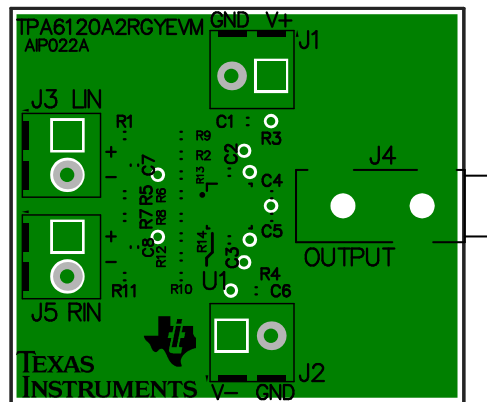

Figure 28. Example PCB Layout, Bottom Layer and Silkscreen, Top View

### Layout Example (continued)

This is part of a 4-layer board, where ground, V+, V- are on the bottom and two middle traces, respectively. Key items to note in this layout:

1. R4 and R3 are the output resistors in the schematic. They are sized as 0603 surface mount resistors instead of 0402 for their thermal capacity, as they will be dissipating heat, depending on the output power.
2. Traces are kept as short as possible to avoid any capacitance or oscillation issues.
3. In systems that may be using the DWP package with through hole resistors, it's strongly suggested that the input and output pins and components do not have a ground plane directly beneath them, to avoid stray capacitance.

## 13 Device and Documentation Support

### 13.1 Documentation Support (if applicable)

#### 13.1.1 Related Documentation

[Headphone Amplifier Parametric Table](#)

### 13.2 Trademarks

PowerPAD is a trademark of Texas Instruments.

### 13.3 Electrostatic Discharge Caution



These devices have limited built-in ESD protection. The leads should be shorted together or the device placed in conductive foam during storage or handling to prevent electrostatic damage to the MOS gates.

### 13.4 Glossary

[SLYZ022](#) — *TI Glossary*.

This glossary lists and explains terms, acronyms, and definitions.

## 14 Mechanical, Packaging, and Orderable Information

The following pages include mechanical packaging and orderable information. This information is the most current data available for the designated devices. This data is subject to change without notice and revision of this document. For browser-based versions of this data sheet, refer to the left-hand navigation.

**PACKAGING INFORMATION**

Orderable Device	Status (1)	Package Type	Package Drawing	Pins	Package Qty	Eco Plan (2)	Lead/Ball Finish (6)	MSL Peak Temp (3)	Op Temp (°C)	Device Marking (4/5)	Samples
TPA6120A2DWP	ACTIVE	SO PowerPAD	DWP	20	25	Green (RoHS & no Sb/Br)	CU NIPDAU	Level-2-260C-1 YEAR	-40 to 85	6120A2	<a href="#">Samples</a>
TPA6120A2DWPG4	ACTIVE	SO PowerPAD	DWP	20	25	Green (RoHS & no Sb/Br)	CU NIPDAU	Level-2-260C-1 YEAR	-40 to 85	6120A2	<a href="#">Samples</a>
TPA6120A2DWPR	ACTIVE	SO PowerPAD	DWP	20	2000	Green (RoHS & no Sb/Br)	CU NIPDAU	Level-2-260C-1 YEAR	-40 to 85	6120A2	<a href="#">Samples</a>
TPA6120A2DWPRG4	ACTIVE	SO PowerPAD	DWP	20	2000	Green (RoHS & no Sb/Br)	CU NIPDAU	Level-2-260C-1 YEAR	-40 to 85	6120A2	<a href="#">Samples</a>
TPA6120A2RGYR	ACTIVE	VQFN	RGY	14	3000	Green (RoHS & no Sb/Br)	CU NIPDAU	Level-2-260C-1 YEAR	-40 to 85	6120A2	<a href="#">Samples</a>
TPA6120A2RGYT	ACTIVE	VQFN	RGY	14	250	Green (RoHS & no Sb/Br)	CU NIPDAU	Level-2-260C-1 YEAR	-40 to 85	6120A2	<a href="#">Samples</a>

(1) The marketing status values are defined as follows:

**ACTIVE:** Product device recommended for new designs.

**LIFEBUY:** TI has announced that the device will be discontinued, and a lifetime-buy period is in effect.

**NRND:** Not recommended for new designs. Device is in production to support existing customers, but TI does not recommend using this part in a new design.

**PREVIEW:** Device has been announced but is not in production. Samples may or may not be available.

**OBSELETE:** TI has discontinued the production of the device.

(2) Eco Plan - The planned eco-friendly classification: Pb-Free (RoHS), Pb-Free (RoHS Exempt), or Green (RoHS & no Sb/Br) - please check <http://www.ti.com/productcontent> for the latest availability information and additional product content details.

**TBD:** The Pb-Free/Green conversion plan has not been defined.

**Pb-Free (RoHS):** TI's terms "Lead-Free" or "Pb-Free" mean semiconductor products that are compatible with the current RoHS requirements for all 6 substances, including the requirement that lead not exceed 0.1% by weight in homogeneous materials. Where designed to be soldered at high temperatures, TI Pb-Free products are suitable for use in specified lead-free processes.

**Pb-Free (RoHS Exempt):** This component has a RoHS exemption for either 1) lead-based flip-chip solder bumps used between the die and package, or 2) lead-based die adhesive used between the die and leadframe. The component is otherwise considered Pb-Free (RoHS compatible) as defined above.

**Green (RoHS & no Sb/Br):** TI defines "Green" to mean Pb-Free (RoHS compatible), and free of Bromine (Br) and Antimony (Sb) based flame retardants (Br or Sb do not exceed 0.1% by weight in homogeneous material)

(3) MSL, Peak Temp. - The Moisture Sensitivity Level rating according to the JEDEC industry standard classifications, and peak solder temperature.

(4) There may be additional marking, which relates to the logo, the lot trace code information, or the environmental category on the device.

(5) Multiple Device Markings will be inside parentheses. Only one Device Marking contained in parentheses and separated by a "~" will appear on a device. If a line is indented then it is a continuation of the previous line and the two combined represent the entire Device Marking for that device.

<sup>(6)</sup> Lead/Ball Finish - Orderable Devices may have multiple material finish options. Finish options are separated by a vertical ruled line. Lead/Ball Finish values may wrap to two lines if the finish value exceeds the maximum column width.

**Important Information and Disclaimer:** The information provided on this page represents TI's knowledge and belief as of the date that it is provided. TI bases its knowledge and belief on information provided by third parties, and makes no representation or warranty as to the accuracy of such information. Efforts are underway to better integrate information from third parties. TI has taken and continues to take reasonable steps to provide representative and accurate information but may not have conducted destructive testing or chemical analysis on incoming materials and chemicals. TI and TI suppliers consider certain information to be proprietary, and thus CAS numbers and other limited information may not be available for release.

In no event shall TI's liability arising out of such information exceed the total purchase price of the TI part(s) at issue in this document sold by TI to Customer on an annual basis.

## TAPE AND REEL INFORMATION



### QUADRANT ASSIGNMENTS FOR PIN 1 ORIENTATION IN TAPE



\*All dimensions are nominal

Device	Package Type	Package Drawing	Pins	SPQ	Reel Diameter (mm)	Reel Width W1 (mm)	A0 (mm)	B0 (mm)	K0 (mm)	P1 (mm)	W (mm)	Pin1 Quadrant
TPA6120A2DWPR	SO Power PAD	DWP	20	2000	330.0	24.4	10.8	13.3	2.7	12.0	24.0	Q1

TAPE AND REEL BOX DIMENSIONS



\*All dimensions are nominal

Device	Package Type	Package Drawing	Pins	SPQ	Length (mm)	Width (mm)	Height (mm)
TPA6120A2DWPR	SO PowerPAD	DWP	20	2000	367.0	367.0	45.0

DWP (R-PDSO-G\*\*) 20 PINS SHOWN

PowerPAD™ PLASTIC SMALL-OUTLINE PACKAGE

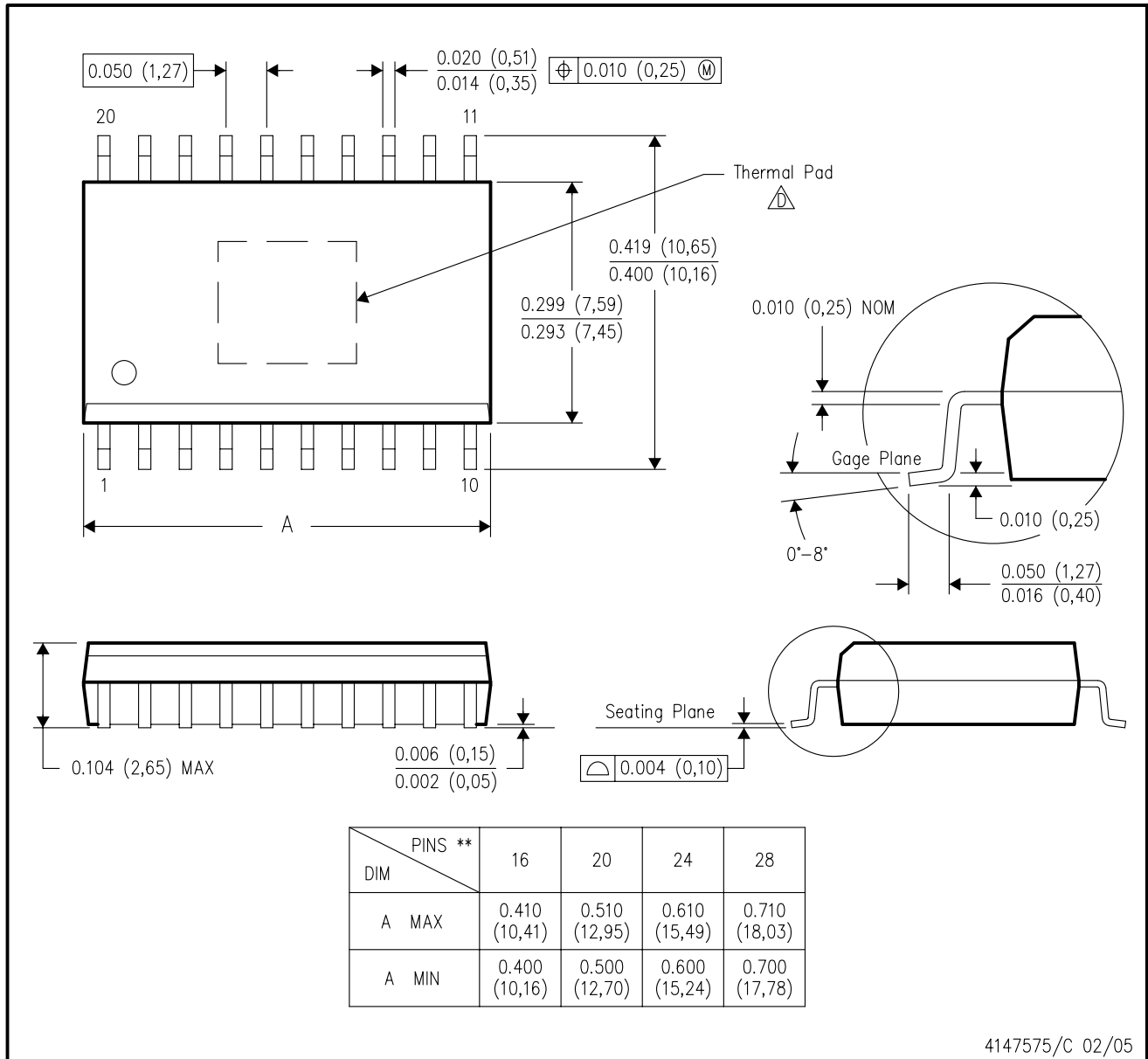

- NOTES:
- A. All linear dimensions are in inches (millimeters).
  - B. This drawing is subject to change without notice.
  - C. Body dimensions do not include mold flash or protrusion not to exceed 0.006 (0,15).
- △ This package is designed to be soldered to a thermal pad on the board. Refer to Technical Brief, PowerPad Thermally Enhanced Package, Texas Instruments Literature No. SLMA002 for information regarding recommended board layout. This document is available at [www.ti.com](http://www.ti.com) <<http://www.ti.com>>. See the product data sheet for details regarding the exposed thermal pad dimensions.

PowerPAD is a trademark of Texas Instruments.

# THERMAL PAD MECHANICAL DATA

DWP (R-PDSO-G20)

PowerPAD™ PLASTIC SMALL OUTLINE

## THERMAL INFORMATION

This PowerPAD™ package incorporates an exposed thermal pad that is designed to be attached to a printed circuit board (PCB). The thermal pad must be soldered directly to the PCB. After soldering, the PCB can be used as a heatsink. In addition, through the use of thermal vias, the thermal pad can be attached directly to the appropriate copper plane shown in the electrical schematic for the device, or alternatively, can be attached to a special heatsink structure designed into the PCB. This design optimizes the heat transfer from the integrated circuit (IC).

For additional information on the PowerPAD package and how to take advantage of its heat dissipating abilities, refer to Technical Brief, PowerPAD Thermally Enhanced Package, Texas Instruments Literature No. SLMA002 and Application Brief, PowerPAD Made Easy, Texas Instruments Literature No. SLMA004. Both documents are available at [www.ti.com](http://www.ti.com).

The exposed thermal pad dimensions for this package are shown in the following illustration.

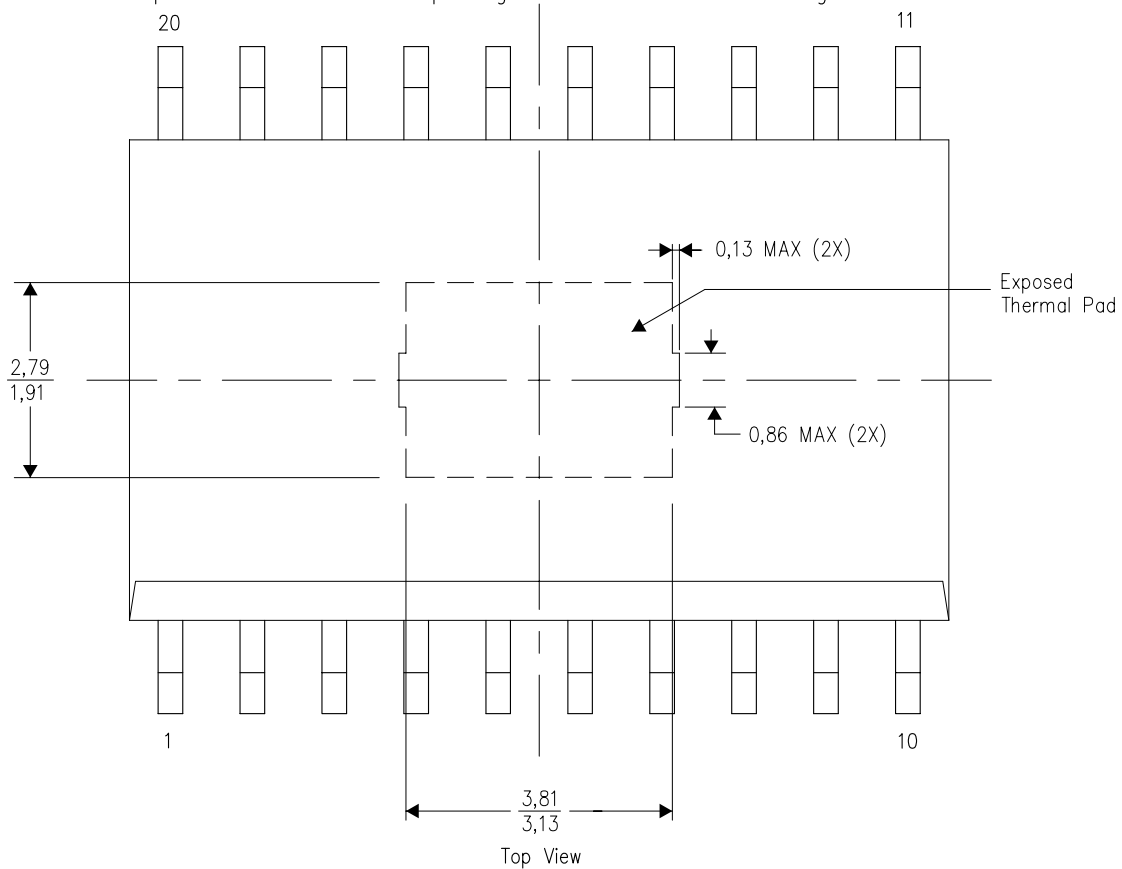

Exposed Thermal Pad Dimensions

4206325-4/E 12/10

NOTE: A. All linear dimensions are in millimeters

DWP (R-PDSO-G20)

PowerPAD™ PLASTIC SMALL OUTLINE

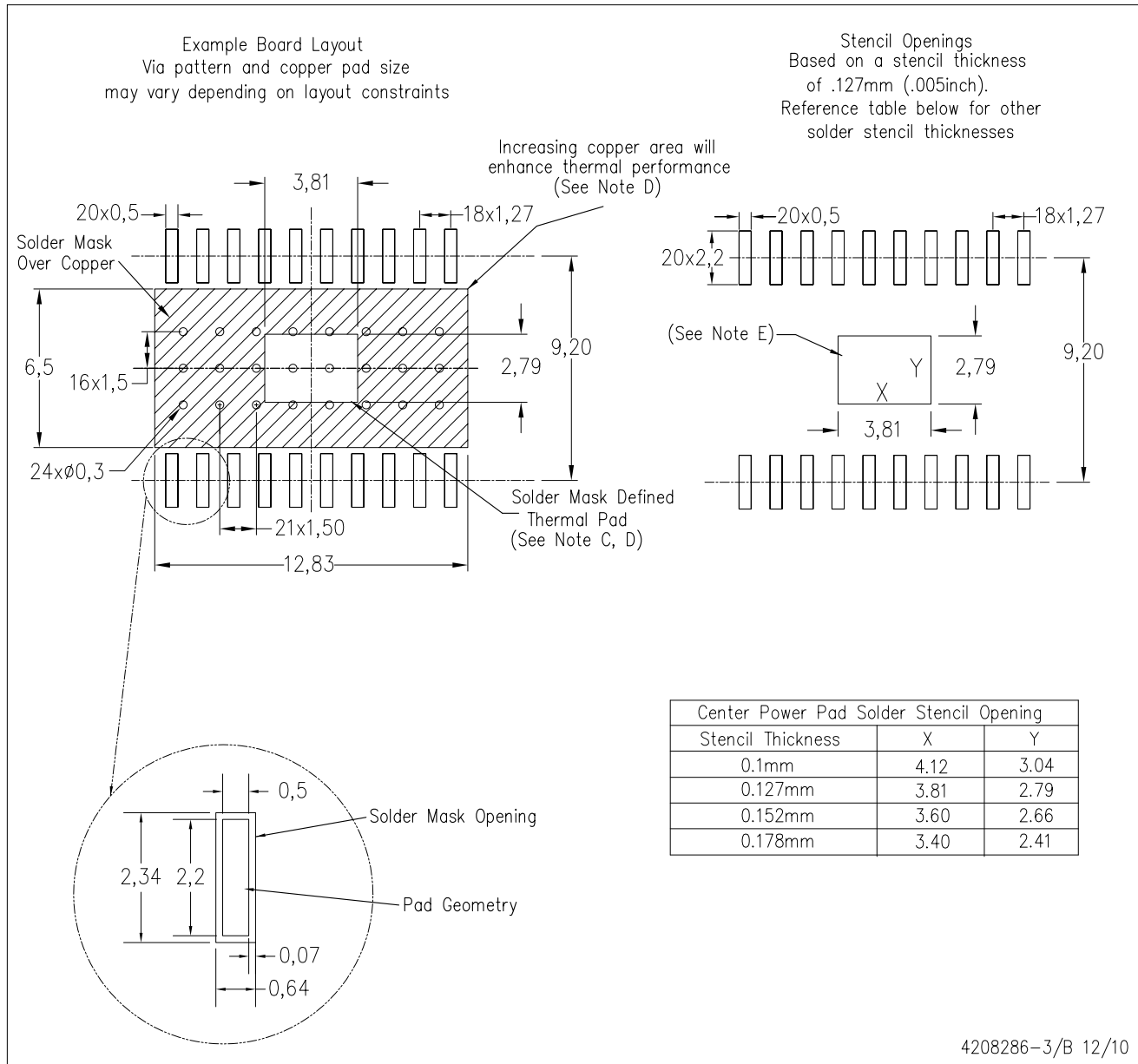

- NOTES:
- A. All linear dimensions are in millimeters.
  - B. This drawing is subject to change without notice.
  - C. Customers should place a note on the circuit board fabrication drawing not to alter the center solder mask defined pad.
  - D. This package is designed to be soldered to a thermal pad on the board. Refer to Technical Brief, PowerPad Thermally Enhanced Package, Texas Instruments Literature No. SLMA002, SLMA004, and also the Product Data Sheets for specific thermal information, via requirements, and recommended board layout. These documents are available at [www.ti.com](http://www.ti.com) <<http://www.ti.com>>. Publication IPC-7351 is recommended for alternate designs.
  - E. Laser cutting apertures with trapezoidal walls and also rounding corners will offer better paste release. Customers should contact their board assembly site for stencil design recommendations. Example stencil design based on a 50% volumetric metal load solder paste.

PowerPAD is a trademark of Texas Instruments.

RGY (S-PVQFN-N14)

PLASTIC QUAD FLATPACK NO-LEAD

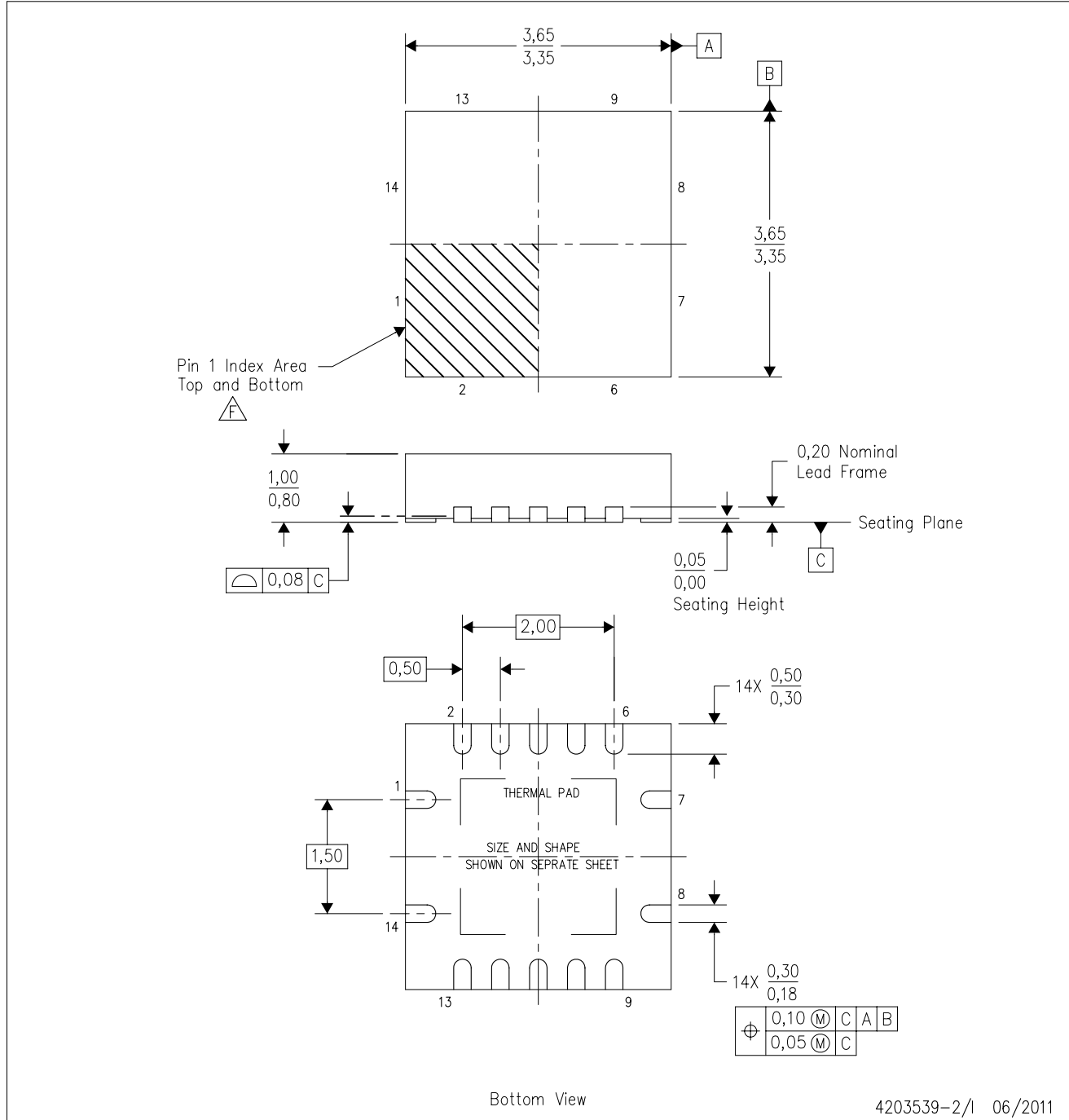

4203539-2/1 06/2011

- NOTES:
- All linear dimensions are in millimeters. Dimensioning and tolerancing per ASME Y14.5M-1994.
  - This drawing is subject to change without notice.
  - QFN (Quad Flatpack No-Lead) package configuration.
  - The package thermal pad must be soldered to the board for thermal and mechanical performance.
  - See the additional figure in the Product Data Sheet for details regarding the exposed thermal pad features and dimensions.
  - Pin 1 identifiers are located on both top and bottom of the package and within the zone indicated. The Pin 1 identifiers are either a molded, marked, or metal feature.
  - Package complies to JEDEC MO-241 variation BA.

RGY (S-PVQFN-N14)

PLASTIC QUAD FLATPACK NO-LEAD

THERMAL INFORMATION

This package incorporates an exposed thermal pad that is designed to be attached directly to an external heatsink. The thermal pad must be soldered directly to the printed circuit board (PCB). After soldering, the PCB can be used as a heatsink. In addition, through the use of thermal vias, the thermal pad can be attached directly to the appropriate copper plane shown in the electrical schematic for the device, or alternatively, can be attached to a special heatsink structure designed into the PCB. This design optimizes the heat transfer from the integrated circuit (IC).

For information on the Quad Flatpack No-Lead (QFN) package and its advantages, refer to Application Report, QFN/SON PCB Attachment, Texas Instruments Literature No. SLUA271. This document is available at [www.ti.com](http://www.ti.com).

The exposed thermal pad dimensions for this package are shown in the following illustration.

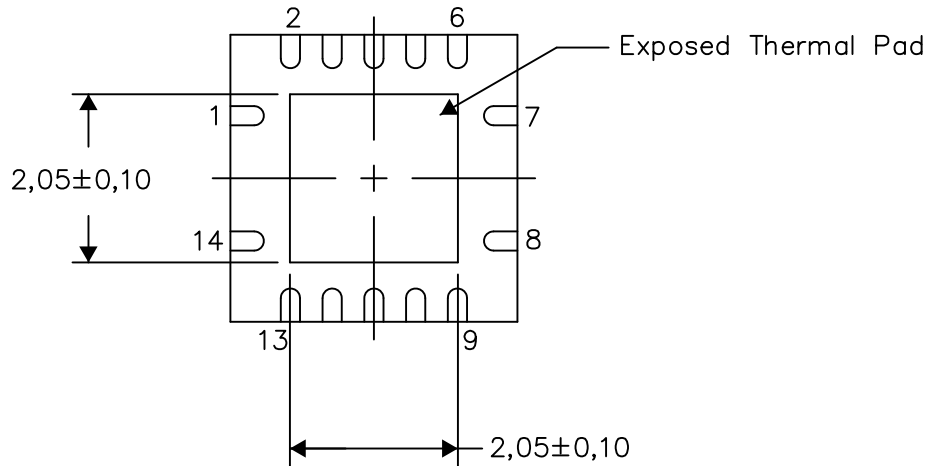

Bottom View

Exposed Thermal Pad Dimensions

4206353-2/P 03/14

NOTE: All linear dimensions are in millimeters

RGY (S-PVQFN-N14)

PLASTIC QUAD FLATPACK NO-LEAD

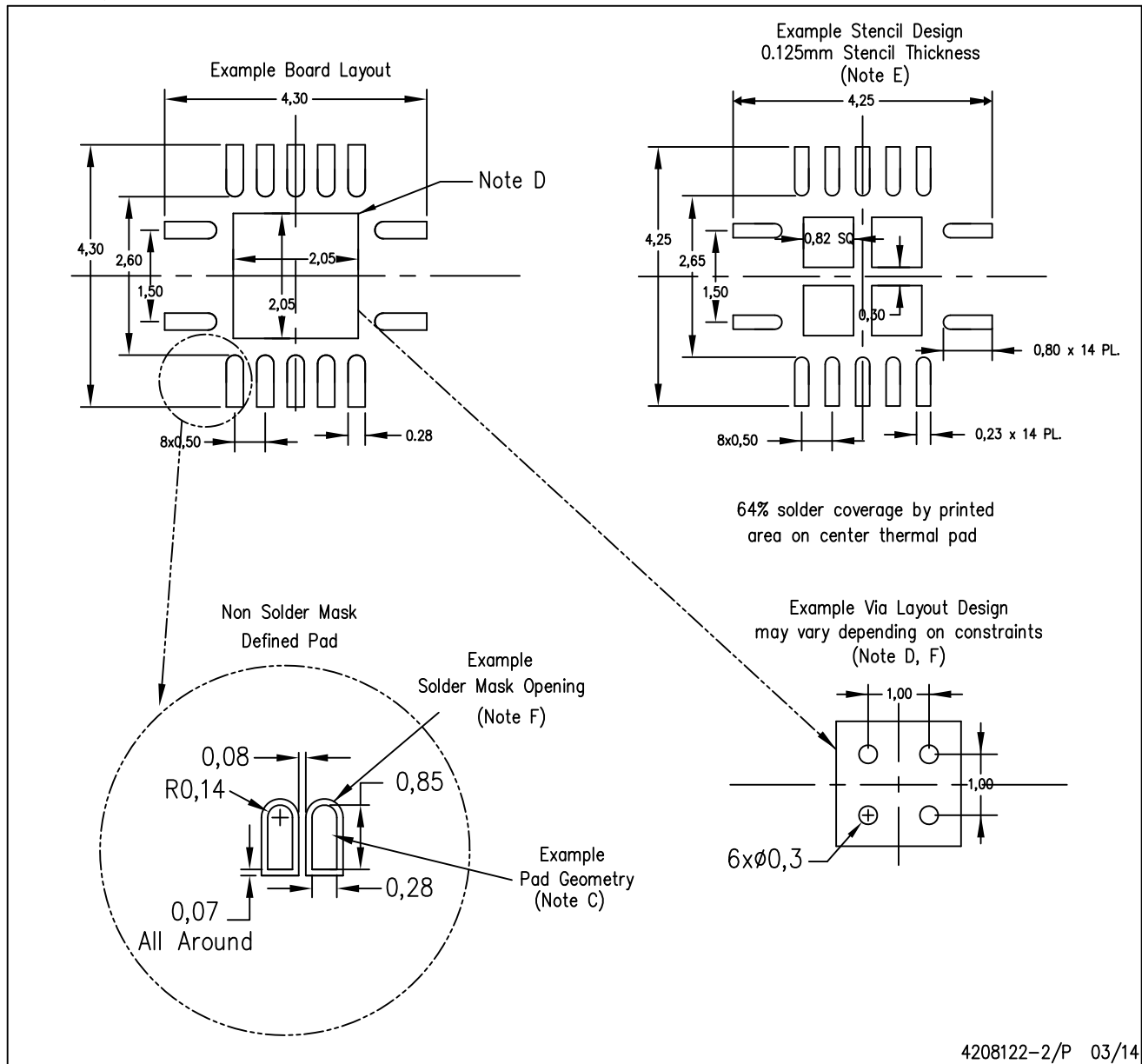

4208122-2/P 03/14

- NOTES:
- All linear dimensions are in millimeters.
  - This drawing is subject to change without notice.
  - Publication IPC-7351 is recommended for alternate designs.
  - This package is designed to be soldered to a thermal pad on the board. Refer to Application Note, Quad Flat-Pack QFN/SON PCB Attachment, Texas Instruments Literature No. SLUA271, and also the Product Data Sheets for specific thermal information, via requirements, and recommended board layout. These documents are available at [www.ti.com](http://www.ti.com) <<http://www.ti.com>>.
  - Laser cutting apertures with trapezoidal walls and also rounding corners will offer better paste release. Customers should contact their board assembly site for stencil design recommendations. Refer to IPC 7525 for stencil design considerations.
  - Customers should contact their board fabrication site for minimum solder mask web tolerances between signal pads.

## IMPORTANT NOTICE

Texas Instruments Incorporated and its subsidiaries (TI) reserve the right to make corrections, enhancements, improvements and other changes to its semiconductor products and services per JESD46, latest issue, and to discontinue any product or service per JESD48, latest issue. Buyers should obtain the latest relevant information before placing orders and should verify that such information is current and complete. All semiconductor products (also referred to herein as "components") are sold subject to TI's terms and conditions of sale supplied at the time of order acknowledgment.

TI warrants performance of its components to the specifications applicable at the time of sale, in accordance with the warranty in TI's terms and conditions of sale of semiconductor products. Testing and other quality control techniques are used to the extent TI deems necessary to support this warranty. Except where mandated by applicable law, testing of all parameters of each component is not necessarily performed.

TI assumes no liability for applications assistance or the design of Buyers' products. Buyers are responsible for their products and applications using TI components. To minimize the risks associated with Buyers' products and applications, Buyers should provide adequate design and operating safeguards.

TI does not warrant or represent that any license, either express or implied, is granted under any patent right, copyright, mask work right, or other intellectual property right relating to any combination, machine, or process in which TI components or services are used. Information published by TI regarding third-party products or services does not constitute a license to use such products or services or a warranty or endorsement thereof. Use of such information may require a license from a third party under the patents or other intellectual property of the third party, or a license from TI under the patents or other intellectual property of TI.

Reproduction of significant portions of TI information in TI data books or data sheets is permissible only if reproduction is without alteration and is accompanied by all associated warranties, conditions, limitations, and notices. TI is not responsible or liable for such altered documentation. Information of third parties may be subject to additional restrictions.

Resale of TI components or services with statements different from or beyond the parameters stated by TI for that component or service voids all express and any implied warranties for the associated TI component or service and is an unfair and deceptive business practice. TI is not responsible or liable for any such statements.

Buyer acknowledges and agrees that it is solely responsible for compliance with all legal, regulatory and safety-related requirements concerning its products, and any use of TI components in its applications, notwithstanding any applications-related information or support that may be provided by TI. Buyer represents and agrees that it has all the necessary expertise to create and implement safeguards which anticipate dangerous consequences of failures, monitor failures and their consequences, lessen the likelihood of failures that might cause harm and take appropriate remedial actions. Buyer will fully indemnify TI and its representatives against any damages arising out of the use of any TI components in safety-critical applications.

In some cases, TI components may be promoted specifically to facilitate safety-related applications. With such components, TI's goal is to help enable customers to design and create their own end-product solutions that meet applicable functional safety standards and requirements. Nonetheless, such components are subject to these terms.

No TI components are authorized for use in FDA Class III (or similar life-critical medical equipment) unless authorized officers of the parties have executed a special agreement specifically governing such use.

Only those TI components which TI has specifically designated as military grade or "enhanced plastic" are designed and intended for use in military/aerospace applications or environments. Buyer acknowledges and agrees that any military or aerospace use of TI components which have *not* been so designated is solely at the Buyer's risk, and that Buyer is solely responsible for compliance with all legal and regulatory requirements in connection with such use.

TI has specifically designated certain components as meeting ISO/TS16949 requirements, mainly for automotive use. In any case of use of non-designated products, TI will not be responsible for any failure to meet ISO/TS16949.

### Products

Audio	<a href="http://www.ti.com/audio">www.ti.com/audio</a>
Amplifiers	<a href="http://amplifier.ti.com">amplifier.ti.com</a>
Data Converters	<a href="http://dataconverter.ti.com">dataconverter.ti.com</a>
DLP® Products	<a href="http://www.dlp.com">www.dlp.com</a>
DSP	<a href="http://dsp.ti.com">dsp.ti.com</a>
Clocks and Timers	<a href="http://www.ti.com/clocks">www.ti.com/clocks</a>
Interface	<a href="http://interface.ti.com">interface.ti.com</a>
Logic	<a href="http://logic.ti.com">logic.ti.com</a>
Power Mgmt	<a href="http://power.ti.com">power.ti.com</a>
Microcontrollers	<a href="http://microcontroller.ti.com">microcontroller.ti.com</a>
RFID	<a href="http://www.ti-rfid.com">www.ti-rfid.com</a>
OMAP Applications Processors	<a href="http://www.ti.com/omap">www.ti.com/omap</a>
Wireless Connectivity	<a href="http://www.ti.com/wirelessconnectivity">www.ti.com/wirelessconnectivity</a>

### Applications

Automotive and Transportation	<a href="http://www.ti.com/automotive">www.ti.com/automotive</a>
Communications and Telecom	<a href="http://www.ti.com/communications">www.ti.com/communications</a>
Computers and Peripherals	<a href="http://www.ti.com/computers">www.ti.com/computers</a>
Consumer Electronics	<a href="http://www.ti.com/consumer-apps">www.ti.com/consumer-apps</a>
Energy and Lighting	<a href="http://www.ti.com/energy">www.ti.com/energy</a>
Industrial	<a href="http://www.ti.com/industrial">www.ti.com/industrial</a>
Medical	<a href="http://www.ti.com/medical">www.ti.com/medical</a>
Security	<a href="http://www.ti.com/security">www.ti.com/security</a>
Space, Avionics and Defense	<a href="http://www.ti.com/space-avionics-defense">www.ti.com/space-avionics-defense</a>
Video and Imaging	<a href="http://www.ti.com/video">www.ti.com/video</a>

### TI E2E Community

[e2e.ti.com](http://e2e.ti.com)