

TMS320LF2407A, TMS320LF2406A, TMS320LF2403A, TMS320LF2402A TMS320LC2406A, TMS320LC2404A, TMS320LC2403A, TMS320LC2402A DSP CONTROLLERS

SPRS145L – JULY 2000 – REVISED SEPTEMBER 2007

- High-Performance Static CMOS Technology
 - 25-ns Instruction Cycle Time (40 MHz)
 - 40-MIPS Performance
 - Low-Power 3.3-V Design
- Based on TMS320C2xx DSP CPU Core
 - Code-Compatible With F243/F241/C242
 - Instruction Set and Module Compatible With F240
- Flash (LF) and ROM (LC) Device Options
 - LF240xA: LF2407A, LF2406A, LF2403A, LF2402A
 - LC240xA: LC2406A, LC2404A, LC2403A, LC2402A
- On-Chip Memory
 - Up to 32K Words x 16 Bits of Flash EEPROM (4 Sectors) or ROM
 - Programmable “Code-Security” Feature for the On-Chip Flash/ROM
 - Up to 2.5K Words x 16 Bits of Data/Program RAM
 - 544 Words of Dual-Access RAM
 - Up to 2K Words of Single-Access RAM
- Boot ROM (LF240xA Devices)
 - SCI/SPI Bootloader
- Up to Two Event-Manager (EV) Modules (EVA and EVB), Each Includes:
 - Two 16-Bit General-Purpose Timers
 - Eight 16-Bit Pulse-Width Modulation (PWM) Channels Which Enable:
 - Three-Phase Inverter Control
 - Center- or Edge-Alignment of PWM Channels
 - Emergency PWM Channel Shutdown With External $\overline{\text{PDPINTx}}$ Pin
 - Programmable Deadband (Deadtime) Prevents Shoot-Through Faults
 - Three Capture Units for Time-Stamping of External Events
 - Input Qualifier for Select Pins
 - On-Chip Position Encoder Interface Circuitry
 - Synchronized A-to-D Conversion
 - Designed for AC Induction, BLDC, Switched Reluctance, and Stepper Motor Control
 - Applicable for Multiple Motor and/or Converter Control
- External Memory Interface (LF2407A)
 - 192K Words x 16 Bits of Total Memory: 64K Program, 64K Data, 64K I/O
- Watchdog (WD) Timer Module
- 10-Bit Analog-to-Digital Converter (ADC)
 - 8 or 16 Multiplexed Input Channels
 - 500-ns MIN Conversion Time
 - Selectable Twin 8-State Sequencers Triggered by Two Event Managers
- Controller Area Network (CAN) 2.0B Module (LF2407A, 2406A, 2403A)
- Serial Communications Interface (SCI)
- 16-Bit Serial Peripheral Interface (SPI) (LF2407A, 2406A, LC2404A, 2403A)
- Phase-Locked-Loop (PLL)-Based Clock Generation
- Up to 40 Individually Programmable, Multiplexed General-Purpose Input/Output (GPIO) Pins
- Up to Five External Interrupts (Power Drive Protection, Reset, Two Maskable Interrupts)
- Power Management:
 - Three Power-Down Modes
 - Ability to Power Down Each Peripheral Independently
- Real-Time JTAG-Compliant Scan-Based Emulation, IEEE Standard 1149.1[†] (JTAG)
- Development Tools Include:
 - Texas Instruments (TI) ANSI C Compiler, Assembler/Linker, and Code Composer Studio™ Debugger
 - Evaluation Modules
 - Scan-Based Self-Emulation (XDS510™)
 - Broad Third-Party Digital Motor Control Support
- Package Options
 - 144-Pin LQFP PGE (LF2407A)
 - 100-Pin LQFP PZ (2406A, LC2404A)
 - 64-Pin TQFP PAG (LF2403A, LC2403A, LC2402A)
 - 64-Pin QFP PG (2402A)
- Extended Temperature Options (A and S)
 - A: – 40°C to 85°C
 - S: – 40°C to 125°C



Please be aware that an important notice concerning availability, standard warranty, and use in critical applications of Texas Instruments semiconductor products and disclaimers thereto appears at the end of this data sheet.

Code Composer Studio and XDS510 are trademarks of Texas Instruments.

Other trademarks are the property of their respective owners.

[†] IEEE Standard 1149.1–1990, IEEE Standard Test-Access Port; however, boundary scan is not supported in this device family.

PRODUCTION DATA information is current as of publication date. Products conform to specifications per the terms of Texas Instruments standard warranty. Production processing does not necessarily include testing of all parameters.

 **TEXAS
INSTRUMENTS**

POST OFFICE BOX 1443 • HOUSTON, TEXAS 77251–1443

Copyright © 2005, Texas Instruments Incorporated

**TMS320LF2407A, TMS320LF2406A, TMS320LF2403A, TMS320LF2402A
TMS320LC2406A, TMS320LC2404A, TMS320LC2403A, TMS320LC2402A
DSP CONTROLLERS**

SPRS145L – JULY 2000 – REVISED SEPTEMBER 2007

Table of Contents

Description	4	Controller Area Network (CAN) Module	51
TMS320x240xA Device Summary	5	Serial Peripheral Interface (SPI) Module	55
Functional Block Diagram of the 2407A DSP Controller	6	PLL-Based Clock Module	57
Pinouts	7	Digital I/O and Shared Pin Functions	60
Pin Functions	11	External Memory Interface (LF2407A)	64
Memory Maps	21	Watchdog (WD) Timer Module	65
Peripheral Memory Map of the 2407A/2406A	29	Development Support	67
Device Reset and Interrupts	30	Documentation Support	70
DSP CPU Core	34	LF240xA and LC240xA Electrical Specifications Data	71
TMS320x240xA Instruction Set	34	Absolute Maximum Ratings	71
Scan-Based Emulation	34	Recommended Operating Conditions	71
Functional Block Diagram of the 2407A DSP CPU ..	35	Migrating From LF240xA (Flash) Devices to LC240xA (ROM) Devices	110
Internal Memory	42	Migrating From 240x Devices to 240xA Devices ...	111
Peripherals	45	Migrating From LF240x Devices to LC240xA Devices	112
Event Manager Modules (EVA, EVB)	45	Peripheral Register Description	113
Enhanced Analog-to-Digital Converter (ADC) Module	49	Mechanical Data	126
Serial Communications Interface (SCI) Module	53		



**TMS320LF2407A, TMS320LF2406A, TMS320LF2403A, TMS320LF2402A
TMS320LC2406A, TMS320LC2404A, TMS320LC2403A, TMS320LC2402A
DSP CONTROLLERS**

SPRS145L – JULY 2000 – REVISED SEPTEMBER 2007

REVISION HISTORY

PAGE	HIGHLIGHTS
11	Added the V_{CCA} pin to final note on Table 2
27	Modified LC2403A memory map (Figure 7) in location 8200
50	Added a sentence to the paragraph following Figure 12
59	Added 1/4 W to second column header in Table 10, Loop Filter Component Values With Damping Factor = 2.0
71	Added a note to recommended operating conditions table
72	Added a note to electrical characteristics table
77	Added Figure 23
101	Changed parameter $t_d(WRN)$ in switching characteristics over recommended operating conditions for an external memory interface write at 40 MHz [$H = 0.5t_c(CO)$] table
108	Changed MAX value for I_{CCA} in operating characteristics over recommended operating condition ranges table
110	Added note to Table 18

TMS320LF2407A, TMS320LF2406A, TMS320LF2403A, TMS320LF2402A TMS320LC2406A, TMS320LC2404A, TMS320LC2403A, TMS320LC2402A DSP CONTROLLERS

SPRS145L – JULY 2000 – REVISED SEPTEMBER 2007

description

The TMS320LF240xA and TMS320LC240xA devices, new members of the TMS320C24x™ generation of digital signal processor (DSP) controllers, are part of the TMS320C2000™ platform of fixed-point DSPs. The 240xA devices offer the enhanced TMS320™ DSP architectural design of the C2xx core CPU for low-cost, low-power, and high-performance processing capabilities. Several advanced peripherals, optimized for digital motor and motion control applications, have been integrated to provide a true single-chip DSP controller. While code-compatible with the existing C24x™ DSP controller devices, the 240xA offers increased processing performance (40 MIPS) and a higher level of peripheral integration. See the *TMS320x240xA Device Summary* section for device-specific features.

The 240xA generation offers an array of memory sizes and different peripherals tailored to meet the specific price/performance points required by various applications. Flash devices of up to 32K words offer a cost-effective reprogrammable solution for volume production. The 240xA devices offer a password-based “code security” feature which is useful in preventing unauthorized duplication of proprietary code stored in on-chip Flash/ROM. Note that Flash-based devices contain a 256-word boot ROM to facilitate in-circuit programming. The 240xA family also includes ROM devices that are fully pin-to-pin compatible with their Flash counterparts.

All 240xA devices offer at least one event manager module which has been optimized for digital motor control and power conversion applications. Capabilities of this module include center- and/or edge-aligned PWM generation, programmable deadband to prevent shoot-through faults, and synchronized analog-to-digital conversion. Devices with dual event managers enable multiple motor and/or converter control with a single 240xA DSP controller. Select EV pins have been provided with an “input-qualifier” circuitry, which minimizes inadvertent pin-triggering by glitches.

The high-performance, 10-bit analog-to-digital converter (ADC) has a minimum conversion time of 375 ns and offers up to 16 channels of analog input. The autosequencing capability of the ADC allows a maximum of 16 conversions to take place in a single conversion session without any CPU overhead.

A serial communications interface (SCI) is integrated on all devices to provide asynchronous communication to other devices in the system. For systems requiring additional communication interfaces, the 2407A, 2406A, 2404A, and 2403A offer a 16-bit synchronous serial peripheral interface (SPI). The 2407A, 2406A, and 2403A offer a controller area network (CAN) communications module that meets 2.0B specifications. To maximize device flexibility, functional pins are also configurable as general-purpose inputs/outputs (GPIOs).

To streamline development time, JTAG-compliant scan-based emulation has been integrated into all devices. This provides non-intrusive real-time capabilities required to debug digital control systems. A complete suite of code-generation tools from C compilers to the industry-standard Code Composer Studio™ debugger supports this family. Numerous third-party developers not only offer device-level development tools, but also system-level design and development support.

TMS320C24x, TMS320C2000, TMS320, and C24x are trademarks of Texas Instruments.



**TMS320LF2407A, TMS320LF2406A, TMS320LF2403A, TMS320LF2402A
TMS320LC2406A, TMS320LC2404A, TMS320LC2403A, TMS320LC2402A
DSP CONTROLLERS**

SPRS145L – JULY 2000 – REVISED SEPTEMBER 2007

TMS320x240xA device summary

Note that throughout this data sheet, 240xA is used as a generic name for the LF240xA/LC240xA generation of devices.

Table 1. Hardware Features of 240xA Devices

FEATURE		LF2407A	LF2406A	LF2403A	LF2402A	LC2406A	LC2404A	LC2403A	LC2402A
C2xx DSP Core		Yes	Yes	Yes	Yes	Yes	Yes	Yes	Yes
Instruction Cycle		25 ns	25 ns	25 ns	25 ns	25 ns	25 ns	25 ns	25 ns
MIPS (40 MHz)		40 MIPS	40 MIPS	40 MIPS	40 MIPS	40 MIPS	40 MIPS	40 MIPS	40 MIPS
RAM (16-bit word)	Dual-Access RAM (DARAM)	544	544	544	544	544	544	544	544
	Single-Access RAM (SARAM)	2K	2K	512	512	2K	1K	512	—
3.3-V On-chip Flash (16-bit word) (4 sectors: 4K, 12K, 12K, 4K)		32K	32K	16K	8K	—	—	—	—
On-chip ROM (16-bit word)		—	—	—	—	32K	16K	16K	6K
Code Security for On-Chip Flash/ROM		Yes	Yes	Yes	Yes	Yes	Yes	Yes	Yes
Boot ROM		Yes	Yes	Yes	Yes	—	—	—	—
External Memory Interface		Yes	—	—	—	—	—	—	—
Event Managers A and B (EVA and EVB)		EVA, EVB	EVA, EVB	EVA	EVA	EVA, EVB	EVA, EVB	EVA	EVA
• General-Purpose (GP) Timers		4	4	2	2	4	4	2	2
• Compare (CMP)/PWM		12/16	12/16	6/8	6/8	12/16	12/16	6/8	6/8
• Capture (CAP)/QEP		6/4	6/4	3/2	3/2	6/4	6/4	3/2	3/2
• Input qualifier circuitry on PDPINT _x , CAP _x , QEP _x , XINT1/2, and ADCSOC pins		Yes	Yes	Yes	Yes	Yes	Yes	Yes	Yes
• Status of PDPINT _x pin reflected in COMCON _x register		Yes	Yes	Yes	Yes	Yes	Yes	Yes	Yes
Watchdog Timer		Yes	Yes	Yes	Yes	Yes	Yes	Yes	Yes
10-Bit ADC		Yes	Yes	Yes	Yes	Yes	Yes	Yes	Yes
• Channels		16	16	8	8	16	16	8	8
• Conversion Time (minimum)		500 ns	500 ns	500 ns	500 ns	500 ns	500 ns	500 ns	500 ns
SPI		Yes	Yes	Yes	—	Yes	Yes	Yes	—
SCI		Yes	Yes	Yes	Yes	Yes	Yes	Yes	Yes
CAN		Yes	Yes	Yes	—	Yes	—	Yes	—
Digital I/O Pins (Shared)		41	41	21	21	41	41	21	21
External Interrupts		5	5	3	3	5	5	3	3
Supply Voltage		3.3 V	3.3 V	3.3 V	3.3 V	3.3 V	3.3 V	3.3 V	3.3 V
Packaging		144-pin PGE	100-pin PZ	64-pin PAG	64-pin PG	100-pin PZ	100-pin PZ	64-pin PAG	64-pin PG, PAG
Product Status: Product Preview (PP) Advance Information (AI) Production Data (PD)		PD	PD	PD	PD	PD	PD	PD	PD

Denotes features that are different/new compared to 240x devices.



TMS320LF2407A, TMS320LF2406A, TMS320LF2403A, TMS320LF2402A TMS320LC2406A, TMS320LC2404A, TMS320LC2403A, TMS320LC2402A DSP CONTROLLERS

SPRS145L – JULY 2000 – REVISED SEPTEMBER 2007

functional block diagram of the 2407A DSP controller

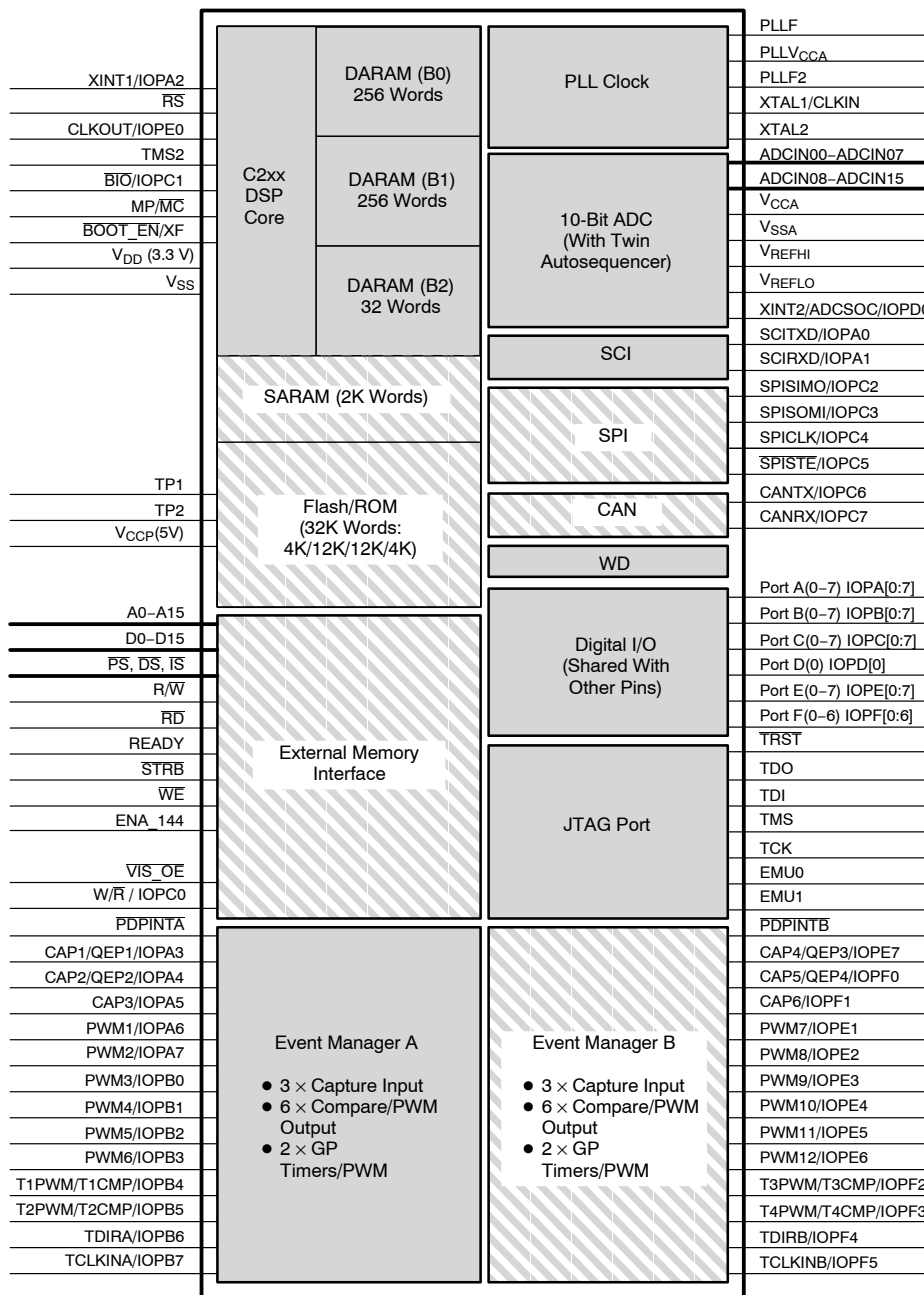

Indicates optional modules.

The memory size and peripheral selection of these modules change for different 240xA devices. See Table 1 for device-specific details.

TMS320LF2407A, TMS320LF2406A, TMS320LF2403A, TMS320LF2402A TMS320LC2406A, TMS320LC2404A, TMS320LC2403A, TMS320LC2402A DSP CONTROLLERS

SPRS145L – JULY 2000 – REVISED SEPTEMBER 2007

pinouts

PGE PACKAGE† (TOP VIEW)

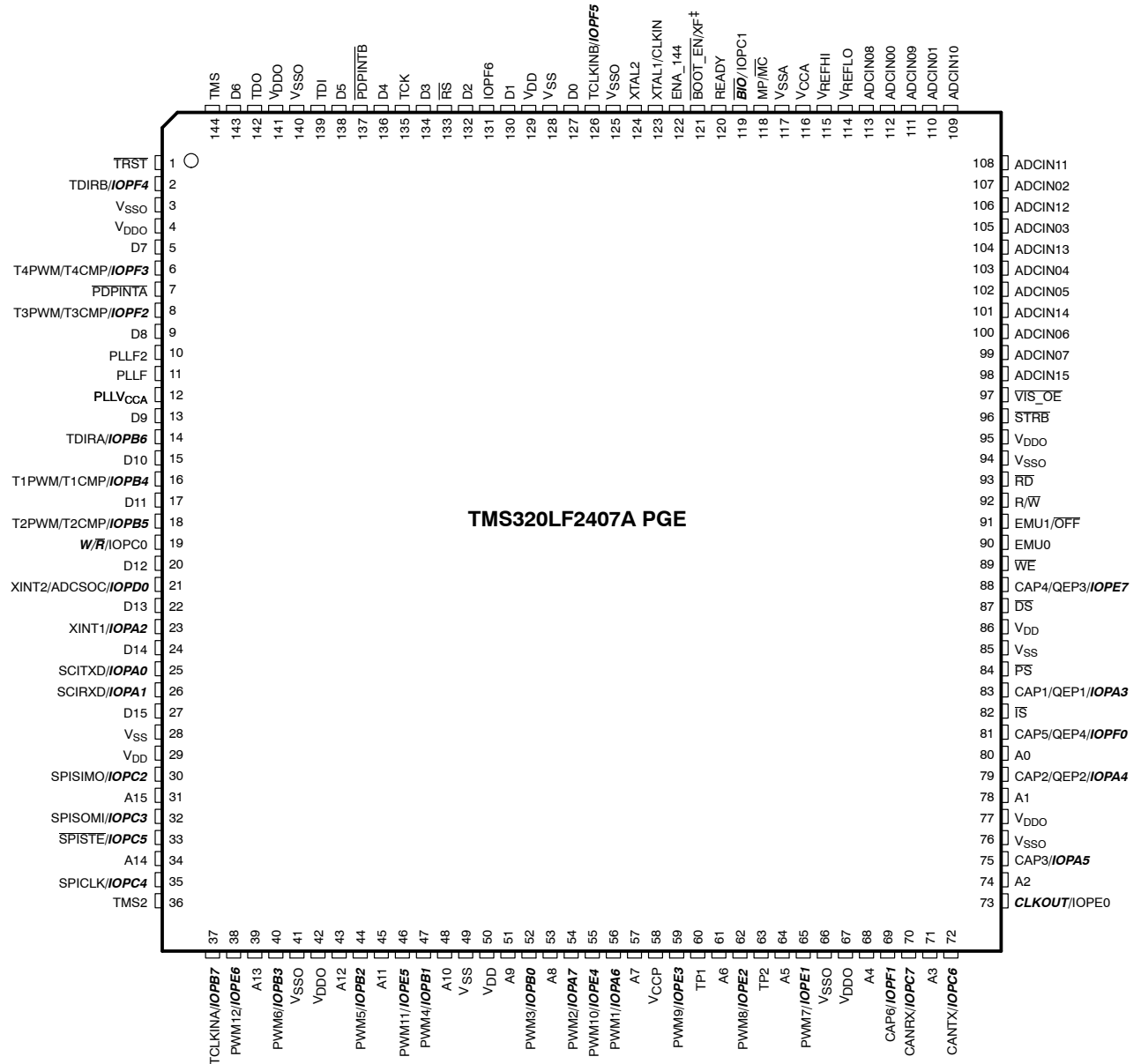

TMS320LF2407A PGE

† **Bold, italicized pin names** indicate pin function after reset.

‡ BOOT_EN is available only on Flash devices.



**TMS320LF2407A, TMS320LF2406A, TMS320LF2403A, TMS320LF2402A
TMS320LC2406A, TMS320LC2404A, TMS320LC2403A, TMS320LC2402A
DSP CONTROLLERS**

SPRS145L – JULY 2000 – REVISED SEPTEMBER 2007

pinouts (continued)

**PZ PACKAGE†
(TOP VIEW)**

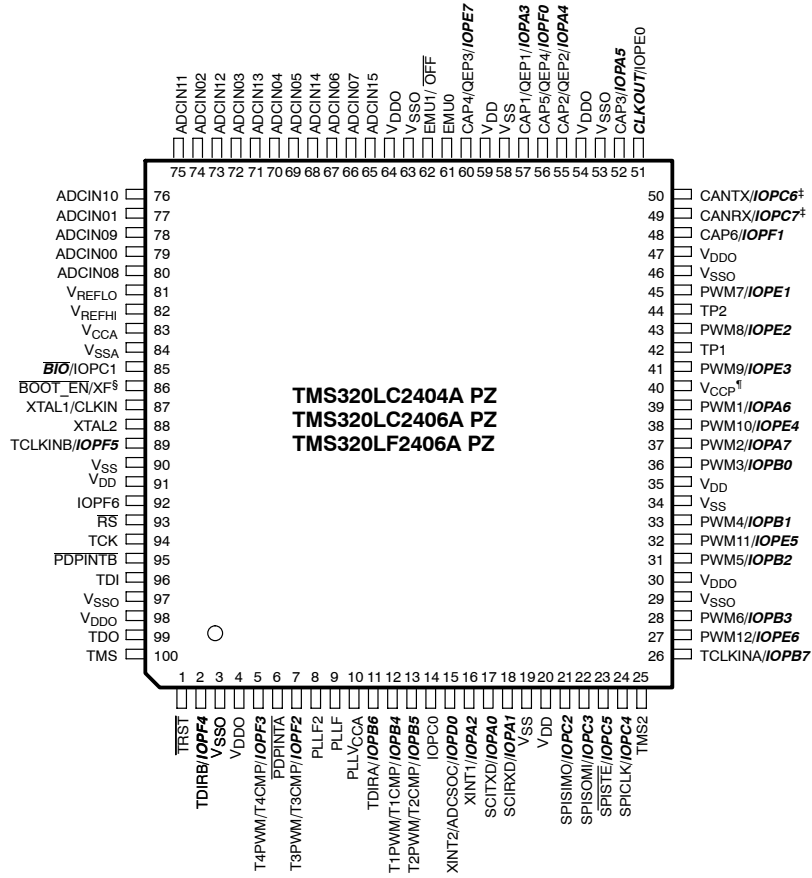

† **Bold, italicized pin names** indicate pin function after reset.

‡ CANTX and CANRX are not available on LC2404A devices.

§ **BOOT_EN** is available only on Flash devices.

¶ On the ROM devices (LC240xA), VCCP is a No Connect (NC).

**TMS320LF2407A, TMS320LF2406A, TMS320LF2403A, TMS320LF2402A
TMS320LC2406A, TMS320LC2404A, TMS320LC2403A, TMS320LC2402A
DSP CONTROLLERS**

SPRS145L – JULY 2000 – REVISED SEPTEMBER 2007

pinouts (continued)

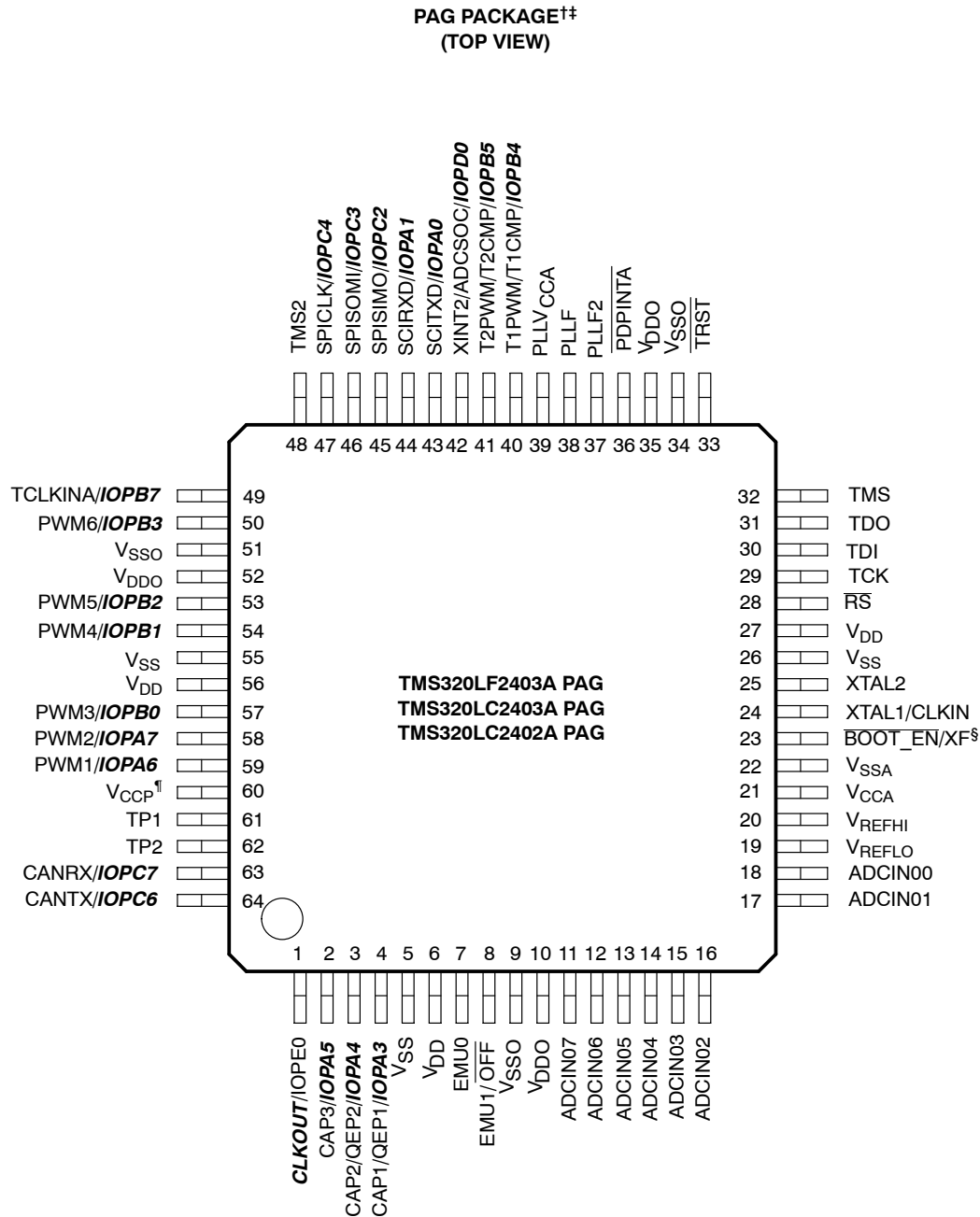

† **Bold, italicized pin names** indicate pin function after reset.

†† For LC2402A, the following pins are different from what is shown:

- Pin 45: ***IOPC2***
- Pin 46: ***IOPC3***
- Pin 47: ***IOPC4***
- Pin 63: ***IOPC7***
- Pin 64: ***IOPC6***

§ BOOT_EN is available only on flash devices.

†† On the ROM devices (LC240xA), VCCP is a No Connect (NC).

TMS320LF2407A, TMS320LF2406A, TMS320LF2403A, TMS320LF2402A TMS320LC2406A, TMS320LC2404A, TMS320LC2403A, TMS320LC2402A DSP CONTROLLERS

SPRS145L – JULY 2000 – REVISED SEPTEMBER 2007

pinouts (continued)

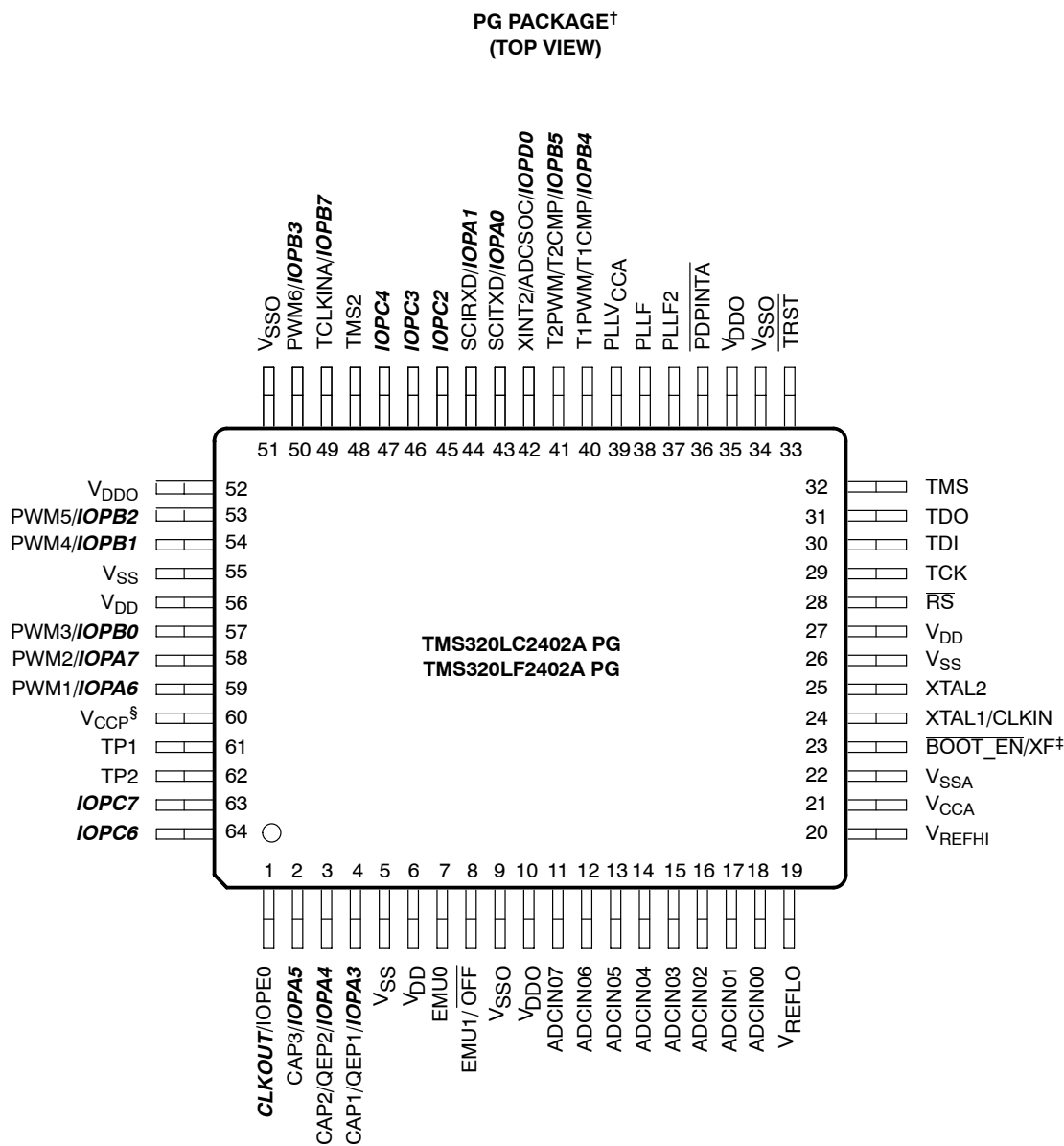

† **Bold, italicized pin names** indicate pin function after reset.

‡ BOOT_EN is available only on Flash devices.

§ On the ROM devices (LC240xA), VCCP is a No Connect (NC).

**TMS320LF2407A, TMS320LF2406A, TMS320LF2403A, TMS320LF2402A
TMS320LC2406A, TMS320LC2404A, TMS320LC2403A, TMS320LC2402A
DSP CONTROLLERS**

SPRS145L – JULY 2000 – REVISED SEPTEMBER 2007

pin functions

The TMS320LF2407A device is the superset of all the 240xA devices. All signals are available on the 2407A device. Table 2 lists the signals available in the 240xA generation of devices.

Table 2. LF240xA and LC240xA Pin List and Package Options^{†‡}

PIN NAME	LF2407A (144-PGE)	2406A (100-PZ)	LC2404A (100-PZ)	2403A, LC2402A (64-PAG) and 2402A (64-PG)	DESCRIPTION
EVENT MANAGER A (EVA)					
CAP1/QEP1//IOPA3	83	57	57	4	Capture input #1/quadrature encoder pulse input #1 (EVA) or GPIO (↑)
CAP2/QEP2//IOPA4	79	55	55	3	Capture input #2/quadrature encoder pulse input #2 (EVA) or GPIO (↑)
CAP3//IOPA5	75	52	52	2	Capture input #3 (EVA) or GPIO (↑)
PWM1//IOPA6	56	39	39	59	Compare/PWM output pin #1 (EVA) or GPIO (↑)
PWM2//IOPA7	54	37	37	58	Compare/PWM output pin #2 (EVA) or GPIO (↑)
PWM3//IOPB0	52	36	36	57	Compare/PWM output pin #3 (EVA) or GPIO (↑)
PWM4//IOPB1	47	33	33	54	Compare/PWM output pin #4 (EVA) or GPIO (↑)
PWM5//IOPB2	44	31	31	53	Compare/PWM output pin #5 (EVA) or GPIO (↑)
PWM6//IOPB3	40	28	28	50	Compare/PWM output pin #6 (EVA) or GPIO (↑)
T1PWM/T1CMP//IOPB4	16	12	12	40	Timer 1 compare output (EVA) or GPIO (↑)
T2PWM/T2CMP//IOPB5	18	13	13	41	Timer 2 compare output (EVA) or GPIO (↑)
TDIRA//IOPB6	14	11	11		Counting direction for general-purpose (GP) timer (EVA) or GPIO. If TDIRA = 1, upward counting is selected. If TDIRA = 0, downward counting is selected. (↑)
TCLKINA//IOPB7	37	26	26	49	External clock input for GP timer (EVA) or GPIO. Note that the timer can also use the internal device clock. (↑)
EVENT MANAGER B (EVB)					
CAP4/QEP3//IOPE7	88	60	60		Capture input #4/quadrature encoder pulse input #3 (EVB) or GPIO (↑)
CAP5/QEP4//IOPF0	81	56	56		Capture input #5/quadrature encoder pulse input #4 (EVB) or GPIO (↑)
CAP6//IOPF1	69	48	48		Capture input #6 (EVB) or GPIO (↑)
PWM7//IOPE1	65	45	45		Compare/PWM output pin #7 (EVB) or GPIO (↑)
PWM8//IOPE2	62	43	43		Compare/PWM output pin #8 (EVB) or GPIO (↑)
PWM9//IOPE3	59	41	41		Compare/PWM output pin #9 (EVB) or GPIO (↑)
PWM10//IOPE4	55	38	38		Compare/PWM output pin #10 (EVB) or GPIO (↑)
PWM11//IOPE5	46	32	32		Compare/PWM output pin #11 (EVB) or GPIO (↑)
PWM12//IOPE6	38	27	27		Compare/PWM output pin #12 (EVB) or GPIO (↑)

[†] **Bold, italicized pin names** indicate pin function after reset.

[‡] GPIO – General-purpose input/output pin. All GPIOs come up as input after reset.

[§] It is highly recommended that V_{CCA} be isolated from the digital supply voltage (and V_{SSA} from digital ground) to maintain the specified accuracy and improve the noise immunity of the ADC.

[¶] Only when all of the following conditions are met: EMU1/OFF is low, TRST is low, and EMU0 is high

[#] No power supply pin (V_{DD}, V_{DDO}, V_{CCA}, V_{SS}, or V_{SSO}) should be left unconnected. All power supply pins must be connected appropriately for proper device operation.

LEGEND: ↑ – Internal pullup ↓ – Internal pulldown (Typical active pullup/pulldown value is ±16 μA.)



**TMS320LF2407A, TMS320LF2406A, TMS320LF2403A, TMS320LF2402A
TMS320LC2406A, TMS320LC2404A, TMS320LC2403A, TMS320LC2402A
DSP CONTROLLERS**

SPRS145L – JULY 2000 – REVISED SEPTEMBER 2007

pin functions (continued)

Table 2. LF240xA and LC240xA Pin List and Package Options^{†‡} (Continued)

PIN NAME	LF2407A (144-PGE)	2406A (100-PZ)	LC2404A (100-PZ)	2403A, LC2402A (64-PAG) and 2402A (64-PG)	DESCRIPTION
EVENT MANAGER B (EVB) (CONTINUED)					
T3PWM/T3CMP/IOPF2	8	7	7		Timer 3 compare output (EVB) or GPIO (↑)
T4PWM/T4CMP/IOPF3	6	5	5		Timer 4 compare output (EVB) or GPIO (↑)
TDIRB/IOPF4	2	2	2		Counting direction for general-purpose (GP) timer (EVB) or GPIO. If TDIRB = 1, upward counting is selected. If TDIRB = 0, downward counting is selected. (↑)
TCLKINB/IOPF5	126	89	89		External clock input for GP timer (EVB) or GPIO. Note that the timer can also use the internal device clock. (↑)
ANALOG-TO-DIGITAL CONVERTER (ADC)					
ADCIN00	112	79	79	18	Analog input #0 to the ADC
ADCIN01	110	77	77	17	Analog input #1 to the ADC
ADCIN02	107	74	74	16	Analog input #2 to the ADC
ADCIN03	105	72	72	15	Analog input #3 to the ADC
ADCIN04	103	70	70	14	Analog input #4 to the ADC
ADCIN05	102	69	69	13	Analog input #5 to the ADC
ADCIN06	100	67	67	12	Analog input #6 to the ADC
ADCIN07	99	66	66	11	Analog input #7 to the ADC
ADCIN08	113	80	80		Analog input #8 to the ADC
ADCIN09	111	78	78		Analog input #9 to the ADC
ADCIN10	109	76	76		Analog input #10 to the ADC
ADCIN11	108	75	75		Analog input #11 to the ADC
ADCIN12	106	73	73		Analog input #12 to the ADC
ADCIN13	104	71	71		Analog input #13 to the ADC
ADCIN14	101	68	68		Analog input #14 to the ADC
ADCIN15	98	65	65		Analog input #15 to the ADC
V _{REFHI}	115	82	82	20	ADC analog high-voltage reference input
V _{REFLO}	114	81	81	19	ADC analog low-voltage reference input
V _{CCA}	116	83	83	21	Analog supply voltage for ADC (3.3 V) [§]
V _{SSA}	117	84	84	22	Analog ground reference for ADC

[†] ***Bold, italicized pin names*** indicate pin function after reset.

[‡] GPIO – General-purpose input/output pin. All GPIOs come up as input after reset.

[§] It is highly recommended that V_{CCA} be isolated from the digital supply voltage (and V_{SSA} from digital ground) to maintain the specified accuracy and improve the noise immunity of the ADC.

[¶] Only when all of the following conditions are met: EMU1/̄OFF is low, TR̄ST is low, and EMU0 is high

[#] No power supply pin (V_{DD}, V_{DDO}, V_{CCA}, V_{SS}, or V_{SSO}) should be left unconnected. All power supply pins must be connected appropriately for proper device operation.

LEGEND: ↑ – Internal pullup ↓ – Internal pulldown (Typical active pullup/pulldown value is ±16 μA.)



**TMS320LF2407A, TMS320LF2406A, TMS320LF2403A, TMS320LF2402A
TMS320LC2406A, TMS320LC2404A, TMS320LC2403A, TMS320LC2402A
DSP CONTROLLERS**

SPRS145L – JULY 2000 – REVISED SEPTEMBER 2007

pin functions (continued)

Table 2. LF240xA and LC240xA Pin List and Package Options^{†‡} (Continued)

PIN NAME	LF2407A (144-PGE)	2406A (100-PZ)	LC2404A (100-PZ)	2403A, LC2402A (64-PAG) and 2402A (64-PG)	DESCRIPTION	
CONTROLLER AREA NETWORK (CAN), SERIAL COMMUNICATIONS INTERFACE (SCI), SERIAL PERIPHERAL INTERFACE (SPI)						
CANRX//IOPC7	CANRX	70	49	–	63	CAN receive data or GPIO (LF2403A) (↑)
	IOPC7	70	49	49	63	GPIO only (2402A) (↑)
CANTX//IOPC6	CANTX	72	50	–	64	CAN transmit data or GPIO (LF2403A) (↑)
	IOPC6	72	50	50	64	GPIO only (2402A) (↑)
SCITXD//IOPA0	25	17	17	–	43	SCI asynchronous serial port transmit data or GPIO (↑)
SCIRXD//IOPA1	26	18	18	–	44	SCI asynchronous serial port receive data or or GPIO (↑)
SPICLK//IOPC4	SPICLK	35	24	24	47	SPI clock or GPIO (LF2403A) (↑)
	IOPC4	35	24	24	47	GPIO only (2402A) (↑)
SPISIMO//IOPC2	SPISIMO	30	21	21	45	SPI slave in, master out or GPIO (LF2403A) (↑)
	IOPC2	30	21	21	45	GPIO only (2402A) (↑)
SPISOMI//IOPC3	SPISOMI	32	22	22	46	SPI slave out, master in or GPIO (LF2403A) (↑)
	IOPC3	32	22	22	46	GPIO only (2402A) (↑)
SPISTE//IOPC5	SPISTE	33	23	23	–	SPI slave transmit-enable (optional) or GPIO (↑)
	IOPC5	33	23	23	–	
EXTERNAL INTERRUPTS, CLOCK						
\overline{RS}	133	93	93	–	28	Device Reset (in) and Watchdog Reset (out). Device reset. \overline{RS} causes the device to terminate execution and to set PC = 0. When \overline{RS} is brought to a high level, execution begins at location 0x0000 of program memory. This pin is driven low by the DSP when a watchdog reset occurs. During watchdog reset, the \overline{RS} pin will be driven low for the watchdog reset duration of 128 CLKIN cycles. The output buffer of this pin is an open-drain with an internal pullup (20 μ A, typical). It is recommended that this pin be driven by an open-drain device. (↑)
$\overline{PDPINTA}$	7	6	6	–	36	Power drive protection interrupt input. This interrupt, when activated, puts the PWM output pins (EVA) in the high-impedance state should motor drive/power converter abnormalities, such as overvoltage or overcurrent, etc., arise. $\overline{PDPINTA}$ is a falling-edge-sensitive interrupt. (↑)

[†] **Bold, italicized pin names** indicate pin function after reset.

[‡] GPIO – General-purpose input/output pin. All GPIOs come up as input after reset.

[§] It is highly recommended that V_{CCA} be isolated from the digital supply voltage (and V_{SSA} from digital ground) to maintain the specified accuracy and improve the noise immunity of the ADC.

[¶] Only when all of the following conditions are met: EMU1/OFF is low, \overline{TRST} is low, and EMU0 is high

[#] No power supply pin (V_{DD} , V_{DDO} , V_{CCA} , V_{SS} , or V_{SSO}) should be left unconnected. All power supply pins must be connected appropriately for proper device operation.

LEGEND: ↑ – Internal pullup ↓ – Internal pulldown (Typical active pullup/pulldown value is $\pm 16 \mu$ A.)



**TMS320LF2407A, TMS320LF2406A, TMS320LF2403A, TMS320LF2402A
TMS320LC2406A, TMS320LC2404A, TMS320LC2403A, TMS320LC2402A
DSP CONTROLLERS**

SPRS145L – JULY 2000 – REVISED SEPTEMBER 2007

pin functions (continued)

Table 2. LF240xA and LC240xA Pin List and Package Options^{†‡} (Continued)

PIN NAME	LF2407A (144-PGE)	2406A (100-PZ)	LC2404A (100-PZ)	2403A, LC2402A (64-PAG) and 2402A (64-PG)	DESCRIPTION
EXTERNAL INTERRUPTS, CLOCK (CONTINUED)					
XINT1/IOPA2	23	16	16		External user interrupt 1 or GPIO. Both XINT1 and XINT2 are edge-sensitive. The edge polarity is programmable. (↑)
XINT2/ADCSOC/IOPD0	21	15	15	42	External user interrupt 2 and ADC start of conversion or GPIO. External “start-of-conversion” input for ADC/GPIO. Both XINT1 and XINT2 are edge-sensitive. The edge polarity is programmable. (↑)
CLKOUT/IOPE0	73	51	51	1	Clock output or GPIO. This pin outputs either the CPU clock (CLKOUT) or the watchdog clock (WDCLK). The selection is made by the CLKSRC bit (bit 14) of the system control and status register (SCSR). This pin can be used as a GPIO if not used as a clock output pin. (↑)
PDPINTB	137	95	95		Power drive protection interrupt input. This interrupt, when activated, puts the PWM output pins (EVB) in the high-impedance state should motor drive/power converter abnormalities, such as overvoltage or overcurrent, etc., arise. PDPINTB is a falling-edge-sensitive interrupt. (↑)
OSCILLATOR, PLL, FLASH, BOOT, AND MISCELLANEOUS					
XTAL1/CLKIN	123	87	87	24	PLL oscillator input pin. Crystal input to PLL/clock source input to PLL. XTAL1/CLKIN is tied to one side of a reference crystal.
XTAL2	124	88	88	25	Crystal output. PLL oscillator output pin. XTAL2 is tied to one side of a reference crystal. This pin goes in the high-impedance state when EMU1/OFF is active low.
PLL_{CCA}	12	10	10	39	PLL supply (3.3 V)
IOPF6	131	92	92		General-purpose I/O (↑)
BOOT_EN / XF	BOOT_EN	121	86	–	Boot ROM enable, GPO, XF. This pin will be sampled as input (BOOT_EN) to update SCSR2.3 (BOOT_EN bit) during reset and then driven as an output signal for XF. After reset, XF is driven high. ROM devices do not have boot ROM, hence, no BOOT_EN modes. The BOOT_EN pin must be driven with a passive circuit only. (↑)
	XF	121	86	86	
PLLF	11	9	9	38	PLL loop filter input 1

[†] **Bold, italicized pin names** indicate pin function after reset.

[‡] GPIO – General-purpose input/output pin. All GPIOs come up as input after reset.

[§] It is highly recommended that V_{CCA} be isolated from the digital supply voltage (and V_{SSA} from digital ground) to maintain the specified accuracy and improve the noise immunity of the ADC.

[¶] Only when all of the following conditions are met: EMU1/OFF is low, TRST is low, and EMU0 is high

[#] No power supply pin (V_{DD}, V_{DDO}, V_{CCA}, V_{SS}, or V_{SSO}) should be left unconnected. All power supply pins must be connected appropriately for proper device operation.

LEGEND: ↑ – Internal pullup ↓ – Internal pulldown (Typical active pullup/pulldown value is ±16 μA.)



**TMS320LF2407A, TMS320LF2406A, TMS320LF2403A, TMS320LF2402A
TMS320LC2406A, TMS320LC2404A, TMS320LC2403A, TMS320LC2402A
DSP CONTROLLERS**

SPRS145L – JULY 2000 – REVISED SEPTEMBER 2007

pin functions (continued)

Table 2. LF240xA and LC240xA Pin List and Package Options^{†‡} (Continued)

PIN NAME	LF2407A (144-PGE)	2406A (100-PZ)	LC2404A (100-PZ)	2403A, LC2402A (64-PAG) and 2402A (64-PG)	DESCRIPTION
OSCILLATOR, PLL, FLASH, BOOT, AND MISCELLANEOUS (CONTINUED)					
PLL2	10	8	8	37	PLL loop filter input 2
V _{CCP} (5V)	58	40	40	60	Flash programming voltage pin. This pin must be connected to a 5-V supply for Flash programming. The Flash cannot be programmed if this pin is connected to GND. When not programming the Flash (i.e., during normal device operation), this pin can either be left connected to the 5-V supply or it can be tied to GND. This pin must not be left floating at any time. Do not use any current-limiting resistor in series with the 5-V supply on this pin. This pin is a “no connect” (NC) on ROM parts (i.e., this pin is not connected to any circuitry internal to the device). Connecting this pin to 5 V or leaving it open makes no difference on ROM parts.
TP1	60	42	42	61	Test pin 1. <i>Do not connect.</i>
TP2	63	44	44	62	Test pin 2. <i>Do not connect.</i>
BIO /IOPC1	119	85	85		Branch control input. \overline{BIO} is polled by the \overline{BCND} pma, \overline{BIO} instruction. If \overline{BIO} is low, a branch is executed. If \overline{BIO} is not used, it should be pulled high. This pin is configured as a branch control input by all device resets. It can be used as a GPIO, if not used as a branch control input. (↑)
EMULATION AND TEST					
EMU0	90	61	61	7	Emulator I/O #0 with internal pullup. When \overline{TRST} is driven high, this pin is used as an interrupt to or from the emulator system and is defined as input/output through the JTAG scan. (↑)
EMU1/ \overline{OFF}	91	62	62	8	Emulator pin 1. Emulator pin 1 disables all outputs. When \overline{TRST} is driven high, EMU1/ \overline{OFF} is used as an interrupt to or from the emulator system and is defined as an input/output through the JTAG scan. When \overline{TRST} is driven low, this pin is configured as \overline{OFF} . EMU1/ \overline{OFF} , when active low, puts all output drivers in the high-impedance state. Note that \overline{OFF} is used exclusively for testing and emulation purposes (not for multiprocessing applications). Therefore, for the \overline{OFF} condition, the following apply: $\overline{TRST} = 0$ $EMU0 = 1$ $EMU1/\overline{OFF} = 0$ (↑)
TCK	135	94	94	29	JTAG test clock with internal pullup (↑)

[†] **Bold, italicized pin names** indicate pin function after reset.

[‡] GPIO – General-purpose input/output pin. All GPIOs come up as input after reset.

[§] It is highly recommended that V_{CCA} be isolated from the digital supply voltage (and V_{SSA} from digital ground) to maintain the specified accuracy and improve the noise immunity of the ADC.

[¶] Only when all of the following conditions are met: EMU1/ \overline{OFF} is low, \overline{TRST} is low, and EMU0 is high

[#] No power supply pin (V_{DD}, V_{DDO}, V_{CCA}, V_{SS}, or V_{SSO}) should be left unconnected. All power supply pins must be connected appropriately for proper device operation.

LEGEND: ↑ – Internal pullup ↓ – Internal pulldown (Typical active pullup/pulldown value is ±16 μA.)



**TMS320LF2407A, TMS320LF2406A, TMS320LF2403A, TMS320LF2402A
TMS320LC2406A, TMS320LC2404A, TMS320LC2403A, TMS320LC2402A
DSP CONTROLLERS**

SPRS145L – JULY 2000 – REVISED SEPTEMBER 2007

pin functions (continued)

Table 2. LF240xA and LC240xA Pin List and Package Options^{†‡} (Continued)

PIN NAME	LF2407A (144-PGE)	2406A (100-PZ)	LC2404A (100-PZ)	2403A, LC2402A (64-PAG) and 2402A (64-PG)	DESCRIPTION
EMULATION AND TEST (CONTINUED)					
TDI	139	96	96	30	JTAG test data input (TDI) with internal pullup. TDI is clocked into the selected register (instruction or data) on a rising edge of TCK. (↑)
TDO	142	99	99	31	JTAG scan out, test data output (TDO). The contents of the selected register (instruction or data) is shifted out of TDO on the falling edge of TCK. (↓)
TMS	144	100	100	32	JTAG test-mode select (TMS) with internal pullup. This serial control input is clocked into the TAP controller on the rising edge of TCK. (↑)
TMS2	36	25	25	48	JTAG test-mode select 2 (TMS2) with internal pullup. This serial control input is clocked into the TAP controller on the rising edge of TCK. Used for test and emulation only. This pin can be left unconnected in user applications. If the PLL bypass mode is desired, TMS2, TMS, and TRST should be held low during reset. (↑)
TRST	1	1	1	33	JTAG test reset with internal pulldown. $\overline{\text{TRST}}$, when driven high, gives the scan system control of the operations of the device. If this signal is not connected or driven low, the device operates in its functional mode, and the test reset signals are ignored. (↓) NOTE: Do not use pullup resistors on TRST; it has an internal pulldown device. $\overline{\text{TRST}}$ is an active high test pin and must be maintained low at all times during normal device operation. In a low-noise environment, TRST may be left floating. In other instances, an external pulldown resistor is highly recommended. The value of this resistor should be based on drive strength of the debugger pods applicable to the design. A 2.2-k Ω resistor generally offers adequate protection. Since this is application-specific, it is recommended that each target board be validated for proper operation of the debugger and the application. (↓)

[†] ***Bold, italicized pin names*** indicate pin function after reset.

[‡] GPIO – General-purpose input/output pin. All GPIOs come up as input after reset.

[§] It is highly recommended that V_{CCA} be isolated from the digital supply voltage (and V_{SSA} from digital ground) to maintain the specified accuracy and improve the noise immunity of the ADC.

[¶] Only when all of the following conditions are met: EMU1/OFF is low, TRST is low, and EMU0 is high

[#] No power supply pin (V_{DD} , V_{DDO} , V_{CCA} , V_{SS} , or V_{SSO}) should be left unconnected. All power supply pins must be connected appropriately for proper device operation.

LEGEND: ↑ – Internal pullup ↓ – Internal pulldown (Typical active pullup/pulldown value is $\pm 16 \mu\text{A}$.)



**TMS320LF2407A, TMS320LF2406A, TMS320LF2403A, TMS320LF2402A
TMS320LC2406A, TMS320LC2404A, TMS320LC2403A, TMS320LC2402A
DSP CONTROLLERS**

SPRS145L – JULY 2000 – REVISED SEPTEMBER 2007

pin functions (continued)

Table 2. LF240xA and LC240xA Pin List and Package Options^{†‡} (Continued)

PIN NAME	LF2407A (144-PGE)	2406A (100-PZ)	LC2404A (100-PZ)	2403A, LC2402A (64-PAG) and 2402A (64-PG)	DESCRIPTION
ADDRESS, DATA, AND MEMORY CONTROL SIGNALS					
\overline{DS}	87				Data space strobe. \overline{IS} , \overline{DS} , and \overline{PS} are always high unless low-level asserted for access to the relevant external memory space or I/O. They are placed in the high-impedance state. [¶]
\overline{IS}	82				I/O space strobe. \overline{IS} , \overline{DS} , and \overline{PS} are always high unless low-level asserted for access to the relevant external memory space or I/O. They are placed in the high-impedance state. [¶]
\overline{PS}	84				Program space strobe. \overline{IS} , \overline{DS} , and \overline{PS} are always high unless low-level asserted for access to the relevant external memory space or I/O. They are placed in the high-impedance state. [¶]
R/W	92				Read/write qualifier signal. R/W indicates transfer direction during communication to an external device. It is normally in read mode (high), unless low level is asserted for performing a write operation. R/W is placed in the high-impedance state. [¶]
$\overline{W/R}$ / IOPC0	<i>W/R</i>	19			Write/Read qualifier or GPIO. This is an inverted R/W signal useful for zero-wait-state memory interface. It is normally low, unless a memory write operation is performed. See Table 12, Port C section, for reset note regarding LF2406A and LF2402A. (†)
	IOPC0	19	14	14	
\overline{RD}	93				Read-enable strobe. Read-select indicates an active, external read cycle. \overline{RD} is active on all external program, data, and I/O reads. \overline{RD} is placed in the high-impedance state. [¶]
WE	89				Write-enable strobe. The falling edge of WE indicates that the device is driving the external data bus (D15–D0). WE is active on all external program, data, and I/O writes. WE is placed in the high-impedance state. [¶]
STRB	96				External memory access strobe. STRB is always high unless asserted low to indicate an external bus cycle. STRB is active for all off-chip accesses. STRB is placed in the high-impedance state. [¶]

[†] **Bold, italicized pin names** indicate pin function after reset.

[‡] GPIO – General-purpose input/output pin. All GPIOs come up as input after reset.

[§] It is highly recommended that V_{CCA} be isolated from the digital supply voltage (and V_{SSA} from digital ground) to maintain the specified accuracy and improve the noise immunity of the ADC.

[¶] Only when all of the following conditions are met: EMU1/OFF is low, TRST is low, and EMU0 is high

[#] No power supply pin (V_{DD}, V_{DDO}, V_{CCA}, V_{SS}, or V_{SSO}) should be left unconnected. All power supply pins must be connected appropriately for proper device operation.

LEGEND: ↑ – Internal pullup ↓ – Internal pulldown (Typical active pullup/pulldown value is ±16 μA.)



**TMS320LF2407A, TMS320LF2406A, TMS320LF2403A, TMS320LF2402A
TMS320LC2406A, TMS320LC2404A, TMS320LC2403A, TMS320LC2402A
DSP CONTROLLERS**

SPRS145L – JULY 2000 – REVISED SEPTEMBER 2007

pin functions (continued)

Table 2. LF240xA and LC240xA Pin List and Package Options^{†‡} (Continued)

PIN NAME	LF2407A (144-PGE)	2406A (100-PZ)	LC2404A (100-PZ)	2403A, LC2402A (64-PAG) and 2402A (64-PG)	DESCRIPTION
ADDRESS, DATA, AND MEMORY CONTROL SIGNALS (CONTINUED)					
READY	120				READY is pulled low to add wait states for external accesses. READY indicates that an external device is prepared for a bus transaction to be completed. If the device is not ready, it pulls the READY pin low. The processor waits one cycle and checks READY again. Note that the processor performs READY-detection if at least one software wait state is programmed. To meet the external READY timing parameters, the wait-state generator control register (WSGR) should be programmed for at least one wait state. (↑)
MP/MC	118				Microprocessor/Microcomputer mode select. If this pin is low during reset, the device is put in microcomputer mode and program execution begins at 0000h of internal program memory (Flash EEPROM). A high value during reset puts the device in microprocessor mode and program execution begins at 0000h of external program memory. This line sets the MP/MC bit (bit 2 in the SCSR2 register). (↓)
ENA_144	122				Active high to enable external interface signals. If pulled low, the 2407A behaves like the 2406A/2403A/2402A—i.e., it has no external memory and generates an illegal address if \overline{DS} is asserted. This pin has an internal pulldown. (↓)
VIS_OE	97				Visibility output enable (active when data bus is output). This pin is active (low) whenever the external data bus is driving as an output during visibility mode. Can be used by external decode logic to prevent data bus contention while running in visibility mode.
A0	80				Bit 0 of the 16-bit address bus
A1	78				Bit 1 of the 16-bit address bus
A2	74				Bit 2 of the 16-bit address bus
A3	71				Bit 3 of the 16-bit address bus
A4	68				Bit 4 of the 16-bit address bus
A5	64				Bit 5 of the 16-bit address bus
A6	61				Bit 6 of the 16-bit address bus
A7	57				Bit 7 of the 16-bit address bus
A8	53				Bit 8 of the 16-bit address bus
A9	51				Bit 9 of the 16-bit address bus
A10	48				Bit 10 of the 16-bit address bus
A11	45				Bit 11 of the 16-bit address bus

[†] ***Bold, italicized pin names*** indicate pin function after reset.

[‡] GPIO – General-purpose input/output pin. All GPIOs come up as input after reset.

[§] It is highly recommended that V_{CCA} be isolated from the digital supply voltage (and V_{SSA} from digital ground) to maintain the specified accuracy and improve the noise immunity of the ADC.

[¶] Only when all of the following conditions are met: EMU1/OFF is low, TRST is low, and EMU0 is high

[#] No power supply pin (V_{DD} , V_{DDO} , V_{CCA} , V_{SS} , or V_{SSO}) should be left unconnected. All power supply pins must be connected appropriately for proper device operation.

LEGEND: ↑ – Internal pullup ↓ – Internal pulldown (Typical active pullup/pulldown value is $\pm 16 \mu A$.)



**TMS320LF2407A, TMS320LF2406A, TMS320LF2403A, TMS320LF2402A
TMS320LC2406A, TMS320LC2404A, TMS320LC2403A, TMS320LC2402A
DSP CONTROLLERS**

SPRS145L – JULY 2000 – REVISED SEPTEMBER 2007

pin functions (continued)

Table 2. LF240xA and LC240xA Pin List and Package Options^{†‡} (Continued)

PIN NAME	LF2407A (144-PGE)	2406A (100-PZ)	LC2404A (100-PZ)	2403A, LC2402A (64-PAG) and 2402A (64-PG)	DESCRIPTION
ADDRESS, DATA, AND MEMORY CONTROL SIGNALS (CONTINUED)					
A12	43				Bit 12 of the 16-bit address bus
A13	39				Bit 13 of the 16-bit address bus
A14	34				Bit 14 of the 16-bit address bus
A15	31				Bit 15 of the 16-bit address bus
D0	127				Bit 0 of 16-bit data bus (↑)
D1	130				Bit 1 of 16-bit data bus (↑)
D2	132				Bit 2 of 16-bit data bus (↑)
D3	134				Bit 3 of 16-bit data bus (↑)
D4	136				Bit 4 of 16-bit data bus (↑)
D5	138				Bit 5 of 16-bit data bus (↑)
D6	143				Bit 6 of 16-bit data bus (↑)
D7	5				Bit 7 of 16-bit data bus (↑)
D8	9				Bit 8 of 16-bit data bus (↑)
D9	13				Bit 9 of 16-bit data bus (↑)
D10	15				Bit 10 of 16-bit data bus (↑)
D11	17				Bit 11 of 16-bit data bus (↑)
D12	20				Bit 12 of 16-bit data bus (↑)
D13	22				Bit 13 of 16-bit data bus (↑)
D14	24				Bit 14 of 16-bit data bus (↑)
D15	27				Bit 15 of 16-bit data bus (↑)
POWER SUPPLY					
$V_{DD}^{\#}$	29	20	20	6	Core supply +3.3 V. Digital logic supply voltage.
	50	35	35	27	
	86	59	59	56	
	129	91	91		
$V_{DDO}^{\#}$	4	4	4	10	I/O buffer supply +3.3 V. Digital logic and buffer supply voltage.
	42	30	30	35	
	67	47	47	52	
	77	54	54		
	95	64	64		
	141	98	98		

[†] **Bold, italicized pin names** indicate pin function after reset.

[‡] GPIO – General-purpose input/output pin. All GPIOs come up as input after reset.

[§] It is highly recommended that V_{CCA} be isolated from the digital supply voltage (and V_{SSA} from digital ground) to maintain the specified accuracy and improve the noise immunity of the ADC.

[¶] Only when all of the following conditions are met: EMU1/OFF is low, TRST is low, and EMU0 is high

[#] No power supply pin (V_{DD} , V_{DDO} , V_{CCA} , V_{SS} , or V_{SSO}) should be left unconnected. All power supply pins must be connected appropriately for proper device operation.

LEGEND: ↑ – Internal pullup ↓ – Internal pulldown (Typical active pullup/pulldown value is $\pm 16 \mu A$.)



**TMS320LF2407A, TMS320LF2406A, TMS320LF2403A, TMS320LF2402A
TMS320LC2406A, TMS320LC2404A, TMS320LC2403A, TMS320LC2402A
DSP CONTROLLERS**

SPRS145L – JULY 2000 – REVISED SEPTEMBER 2007

pin functions (continued)

Table 2. LF240xA and LC240xA Pin List and Package Options^{†‡} (Continued)

PIN NAME	LF2407A (144-PGE)	2406A (100-PZ)	LC2404A (100-PZ)	2403A, LC2402A (64-PAG) and 2402A (64-PG)	DESCRIPTION
POWER SUPPLY (CONTINUED)					
<i>V_{SS}</i> [#]	28	19	19	5	Core ground. Digital logic ground reference.
	49	34	34	26	
	85	58	58	55	
	128	90	90		
<i>V_{SSO}</i> [#]	3	3	3	9	I/O buffer ground. Digital logic and buffer ground reference.
	41	29	29	34	
	66	46	46	51	
	76	53	53		
	94	63	63		
	125	97	97		
	140				

[†] ***Bold, italicized pin names*** indicate pin function after reset.

[‡] GPIO – General-purpose input/output pin. All GPIOs come up as input after reset.

[§] It is highly recommended that V_{CCA} be isolated from the digital supply voltage (and V_{SSA} from digital ground) to maintain the specified accuracy and improve the noise immunity of the ADC.

[¶] Only when all of the following conditions are met: $EMU1/\overline{OFF}$ is low, \overline{TRST} is low, and $EMU0$ is high

[#] No power supply pin (V_{DD} , V_{DDO} , V_{CCA} , V_{SS} , or V_{SSO}) should be left unconnected. All power supply pins must be connected appropriately for proper device operation.

LEGEND: \uparrow – Internal pullup \downarrow – Internal pulldown (Typical active pullup/pulldown value is $\pm 16 \mu A$.)



**TMS320LF2407A, TMS320LF2406A, TMS320LF2403A, TMS320LF2402A
TMS320LC2406A, TMS320LC2404A, TMS320LC2403A, TMS320LC2402A
DSP CONTROLLERS**

SPRS145L – JULY 2000 – REVISED SEPTEMBER 2007

memory maps

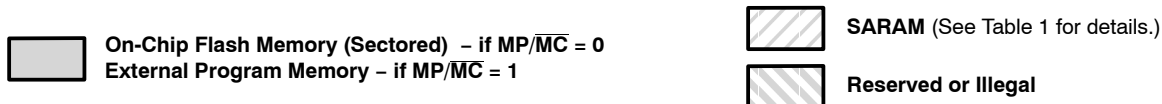
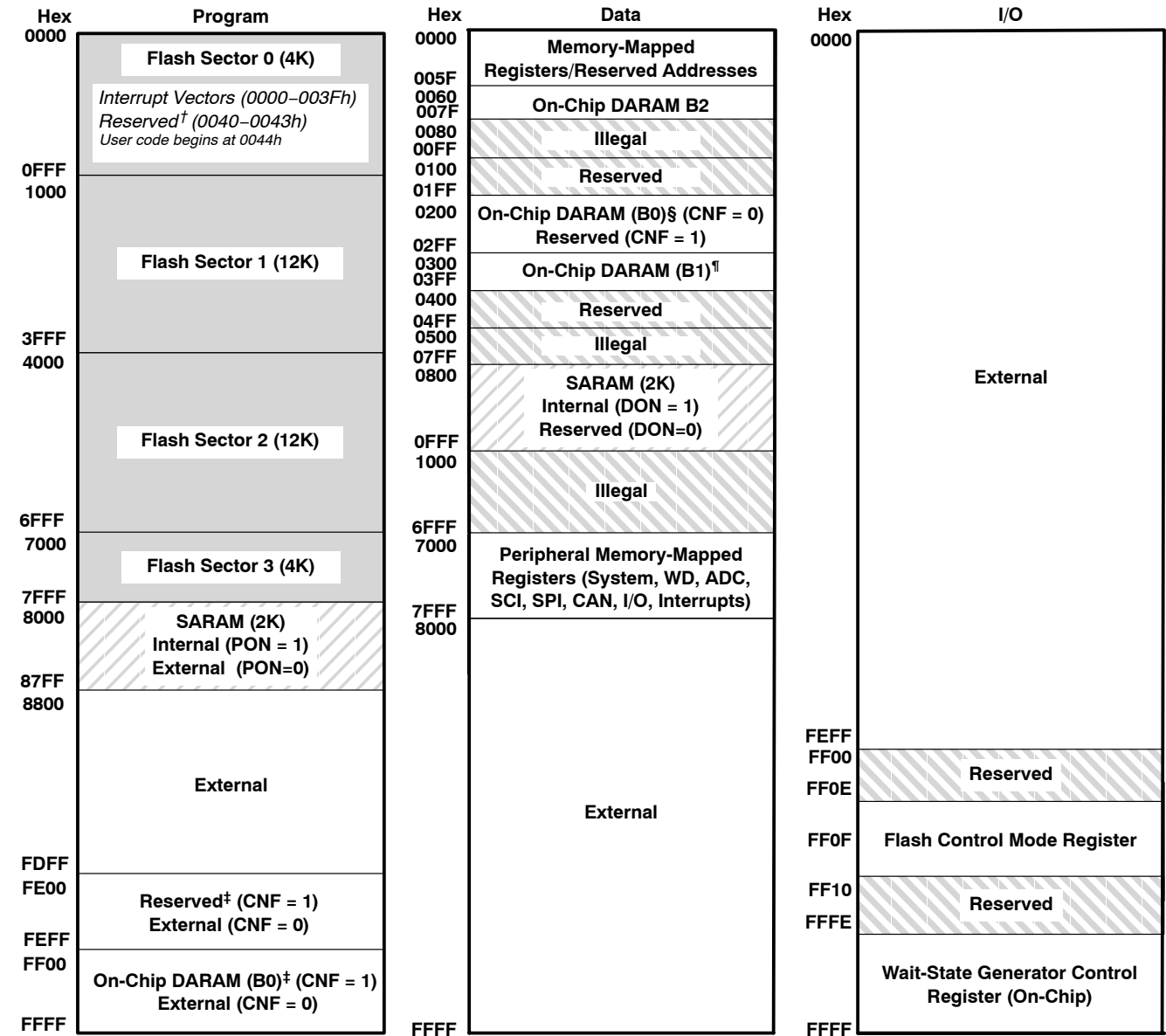

NOTE A: Boot ROM: If the boot ROM is enabled, then addresses 0000–00FF in the program space will be occupied by boot ROM.
† Addresses 0040h–0043h in on-chip program memory are reserved for code security passwords.
‡ When CNF = 1, addresses FE00h–FEFFh and FF00h–FFFFh are mapped to the same physical block (B0) in program-memory space. For example, a write to FE00h has the same effect as a write to FF00h. For simplicity, addresses FE00h–FEFFh are referred to as reserved when CNF = 1.
§ When CNF = 0, addresses 0100h–01FFh and 0200h–02FFh are mapped to the same physical block (B0) in data-memory space. For example, a write to 0100h has the same effect as a write to 0200h. For simplicity, addresses 0100h–01FFh are referred to as reserved.
¶ Addresses 0300h–03FFh and 0400h–04FFh are mapped to the same physical block (B1) in data-memory space. For example, a write to 0400h has the same effect as a write to 0300h. For simplicity, addresses 0400h–04FFh are referred to as reserved.

Figure 1. TMS320LF2407A Memory Map



TMS320LF2407A, TMS320LF2406A, TMS320LF2403A, TMS320LF2402A TMS320LC2406A, TMS320LC2404A, TMS320LC2403A, TMS320LC2402A DSP CONTROLLERS

SPRS145L – JULY 2000 – REVISED SEPTEMBER 2007

memory maps (continued)

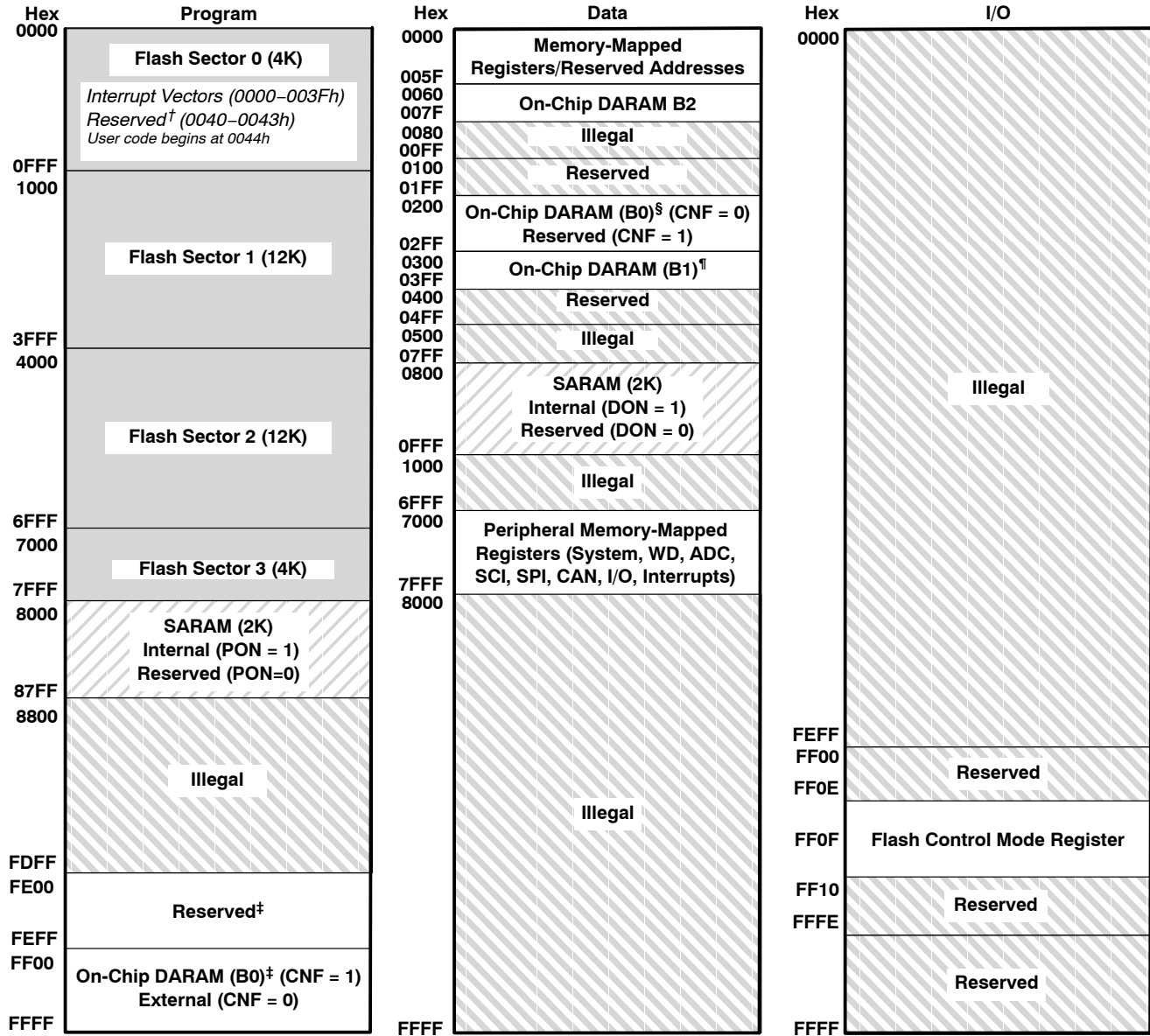

 On-Chip Flash Memory (Sectored)

 SARAM (See Table 1 for details.)

 Reserved or Illegal

NOTE A: Boot ROM: If the boot ROM is enabled, then addresses 0000–00FF in the program space will be occupied by boot ROM.

† Addresses 0040h–0043h in program memory are reserved for code security passwords.

‡ When CNF = 1, addresses FE00h–FEFFh and FF00h–FFFFh are mapped to the same physical block (B0) in program-memory space. For example, a write to FE00h has the same effect as a write to FF00h. For simplicity, addresses FE00h–FEFFh are referred to as reserved.

§ When CNF = 0, addresses 0100h–01FFh and 0200h–02FFh are mapped to the same physical block (B0) in data-memory space. For example, a write to 0100h has the same effect as a write to 0200h. For simplicity, addresses 0100h–01FFh are referred to as reserved.

¶ Addresses 0300h–03FFh and 0400h–04FFh are mapped to the same physical block (B1) in data-memory space. For example, a write to 0400h has the same effect as a write to 0300h. For simplicity, addresses 0400h–04FFh are referred to as reserved.

Figure 2. TMS320LF2406A Memory Map

**TMS320LF2407A, TMS320LF2406A, TMS320LF2403A, TMS320LF2402A
TMS320LC2406A, TMS320LC2404A, TMS320LC2403A, TMS320LC2402A
DSP CONTROLLERS**

SPRS145L – JULY 2000 – REVISED SEPTEMBER 2007

memory maps (continued)

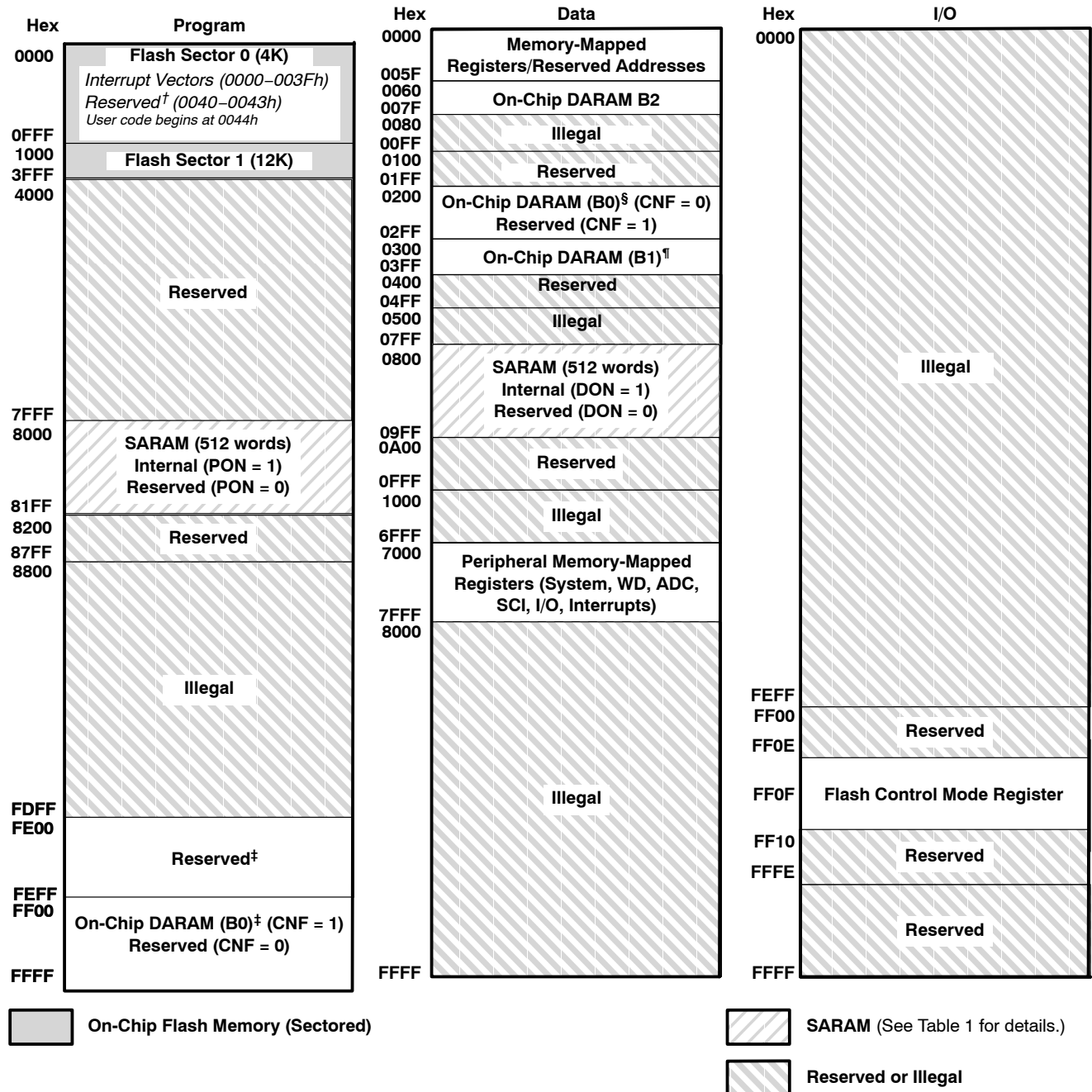

NOTE A: Boot ROM: If the boot ROM is enabled, then addresses 0000–00FF in the program space will be occupied by boot ROM.

† Addresses 0040h–0043h in program memory are reserved for code security passwords.

‡ When CNF = 1, addresses FE00h–FEFFh and FF00h–FFFFh are mapped to the same physical block (B0) in program-memory space. For example, a write to FE00h has the same effect as a write to FF00h. For simplicity, addresses FE00h–FEFFh are referred to as reserved.

§ When CNF = 0, addresses 0100h–01FFh and 0200h–02FFh are mapped to the same physical block (B0) in data-memory space. For example, a write to 0100h has the same effect as a write to 0200h. For simplicity, addresses 0100h–01FFh are referred to as reserved.

¶ Addresses 0300h–03FFh and 0400h–04FFh are mapped to the same physical block (B1) in data-memory space. For example, a write to 0400h has the same effect as a write to 0300h. For simplicity, addresses 0400h–04FFh are referred to as reserved.

Figure 3. TMS320LF2403A Memory Map

TMS320LF2407A, TMS320LF2406A, TMS320LF2403A, TMS320LF2402A TMS320LC2406A, TMS320LC2404A, TMS320LC2403A, TMS320LC2402A DSP CONTROLLERS

SPRS145L – JULY 2000 – REVISED SEPTEMBER 2007

memory maps (continued)

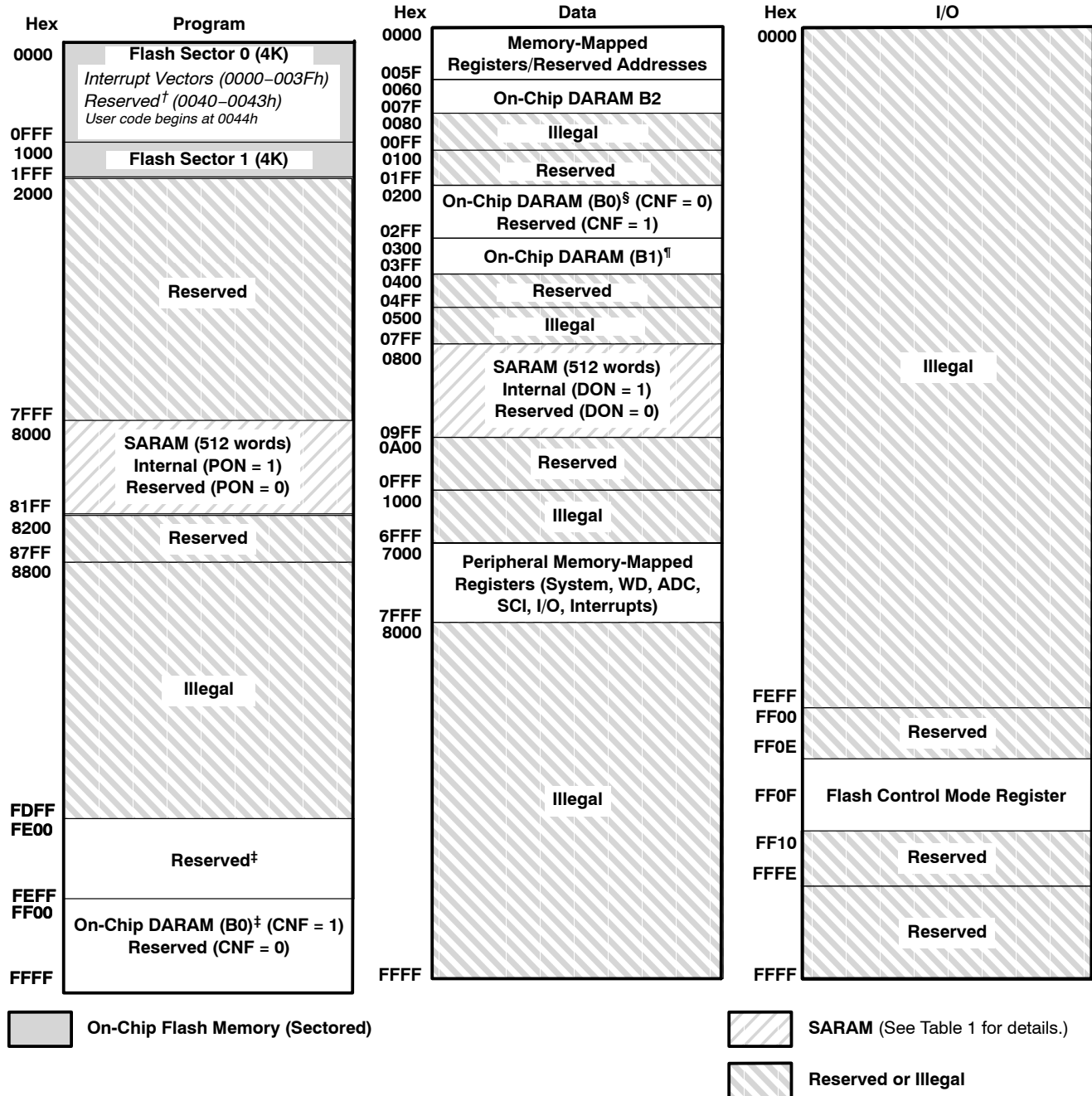

NOTE A: Boot ROM: If the boot ROM is enabled, then addresses 0000–00FF in the program space will be occupied by boot ROM.

† Addresses 0040h–0043h in program memory are reserved for code security passwords.

‡ When CNF = 1, addresses FE00h–FEFFh and FF00h–FFFFh are mapped to the same physical block (B0) in program-memory space. For example, a write to FE00h has the same effect as a write to FF00h. For simplicity, addresses FE00h–FEFFh are referred to as reserved.

§ When CNF = 0, addresses 0100h–01FFh and 0200h–02FFh are mapped to the same physical block (B0) in data-memory space. For example, a write to 0100h has the same effect as a write to 0200h. For simplicity, addresses 0100h–01FFh are referred to as reserved.

¶ Addresses 0300h–03FFh and 0400h–04FFh are mapped to the same physical block (B1) in data-memory space. For example, a write to 0400h has the same effect as a write to 0300h. For simplicity, addresses 0400h–04FFh are referred to as reserved.

Figure 4. TMS320LF2402A Memory Map

TMS320LF2407A, TMS320LF2406A, TMS320LF2403A, TMS320LF2402A TMS320LC2406A, TMS320LC2404A, TMS320LC2403A, TMS320LC2402A DSP CONTROLLERS

SPRS145L – JULY 2000 – REVISED SEPTEMBER 2007

memory maps (continued)

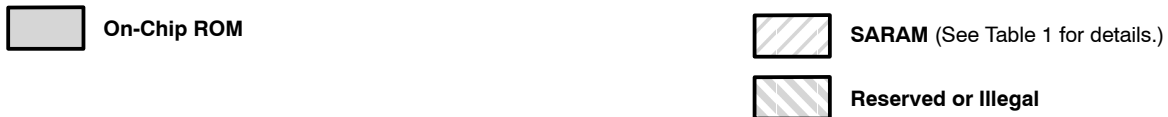
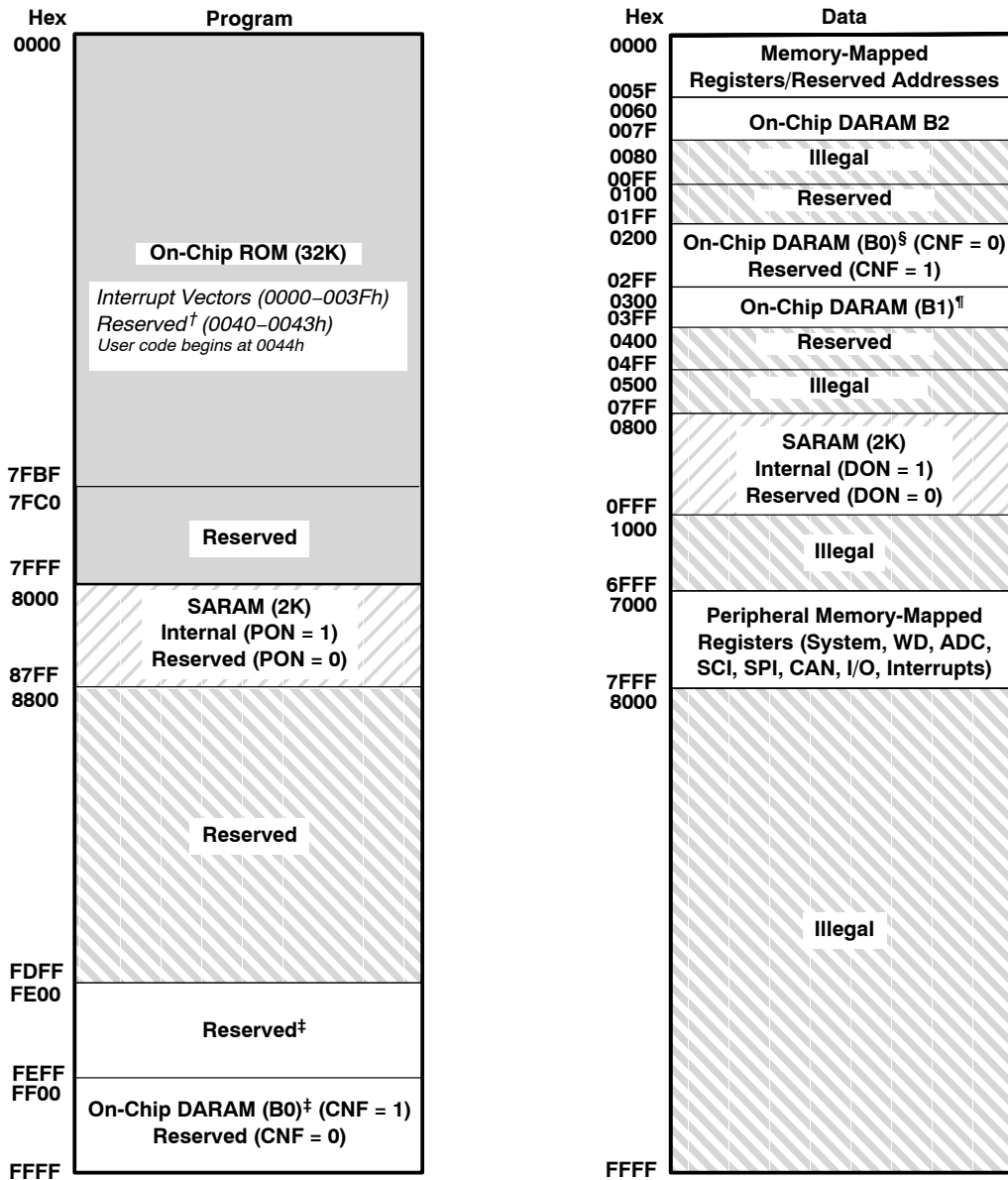

[†] Addresses 0040h–0043h in program memory are reserved for code security passwords.

[‡] When CNF = 1, addresses FE00h–FEFFh and FF00h–FFFFh are mapped to the same physical block (B0) in program-memory space. For example, a write to FE00h has the same effect as a write to FF00h. For simplicity, addresses FE00h–FEFFh are referred to as reserved.

[§] When CNF = 0, addresses 0100h–01FFh and 0200h–02FFh are mapped to the same physical block (B0) in data-memory space. For example, a write to 0100h has the same effect as a write to 0200h. For simplicity, addresses 0100h–01FFh are referred to as reserved.

[¶] Addresses 0300h–03FFh and 0400h–04FFh are mapped to the same physical block (B1) in data-memory space. For example, a write to 0400h has the same effect as a write to 0300h. For simplicity, addresses 0400h–04FFh are referred to as reserved.

Figure 5. TMS320LC2406A Memory Map

**TMS320LF2407A, TMS320LF2406A, TMS320LF2403A, TMS320LF2402A
TMS320LC2406A, TMS320LC2404A, TMS320LC2403A, TMS320LC2402A
DSP CONTROLLERS**

SPRS145L – JULY 2000 – REVISED SEPTEMBER 2007

memory maps (continued)

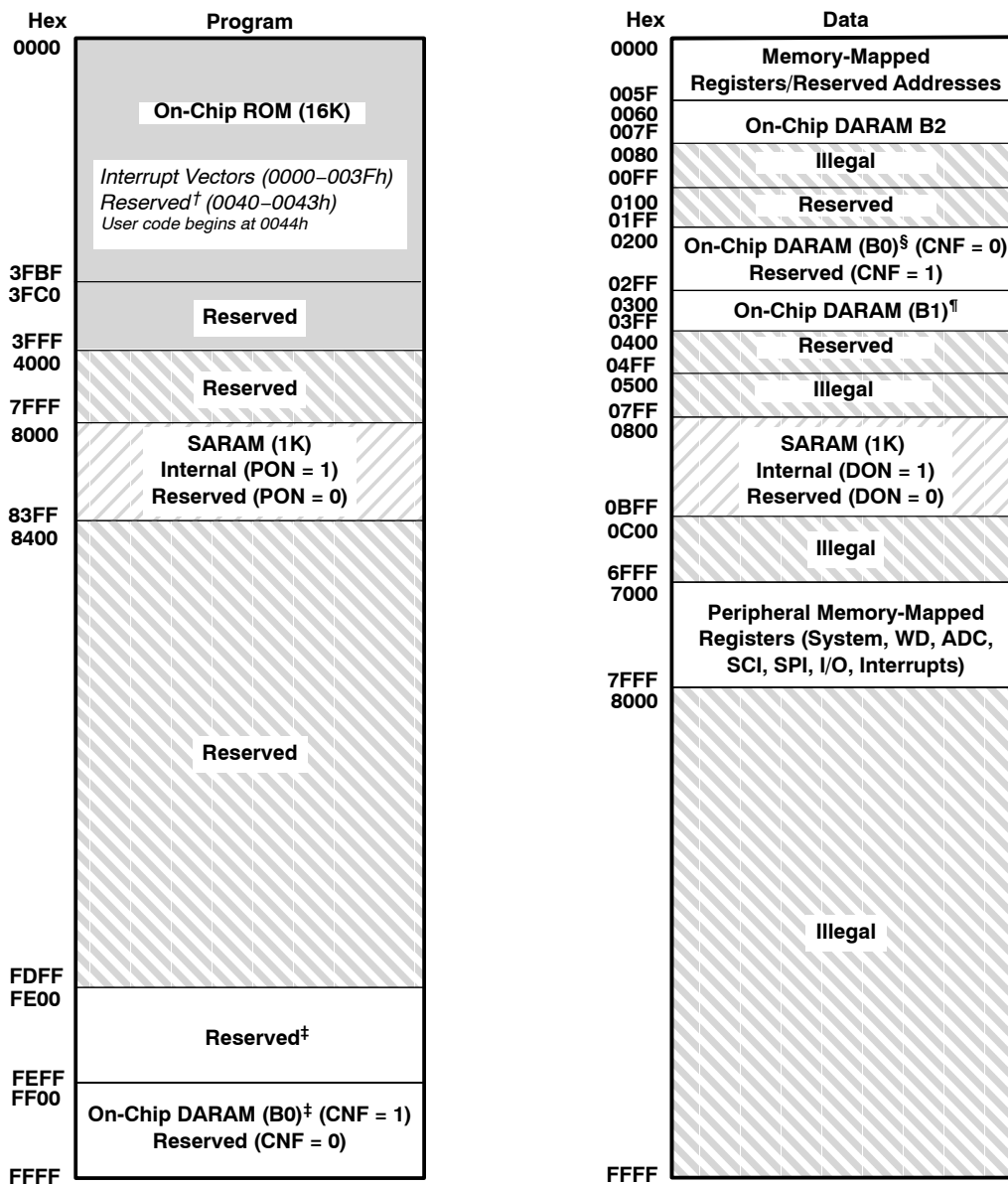

On-Chip ROM

SARAM (See Table 1 for details.)

Reserved or Illegal

† Addresses 0040h–0043h in program memory are reserved for code security passwords.

‡ When CNF = 1, addresses FE00h–FEFFh and FF00h–FFFFh are mapped to the same physical block (B0) in program-memory space. For example, a write to FE00h has the same effect as a write to FF00h. For simplicity, addresses FE00h–FEFFh are referred to as reserved.

§ When CNF = 0, addresses 0100h–01FFh and 0200h–02FFh are mapped to the same physical block (B0) in data-memory space. For example, a write to 0100h has the same effect as a write to 0200h. For simplicity, addresses 0100h–01FFh are referred to as reserved.

¶ Addresses 0300h–03FFh and 0400h–04FFh are mapped to the same physical block (B1) in data-memory space. For example, a write to 0400h has the same effect as a write to 0300h. For simplicity, addresses 0400h–04FFh are referred to as reserved.

Figure 6. TMS320LC2404A Memory Map

TMS320LF2407A, TMS320LF2406A, TMS320LF2403A, TMS320LF2402A TMS320LC2406A, TMS320LC2404A, TMS320LC2403A, TMS320LC2402A DSP CONTROLLERS

SPRS145L – JULY 2000 – REVISED SEPTEMBER 2007

memory maps (continued)

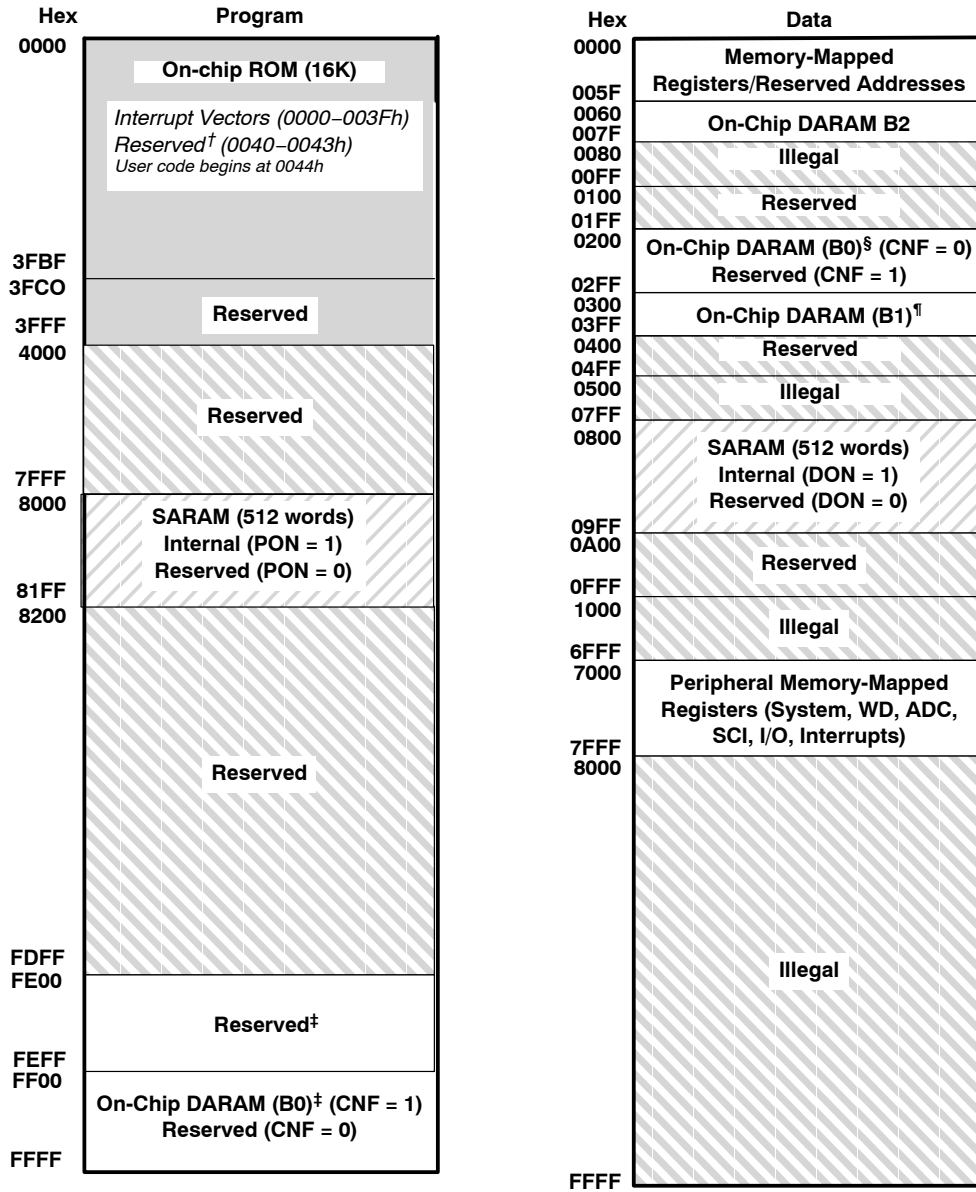

On-Chip ROM

SARAM (See Table 1 for details.)

Reserved or Illegal

† Addresses 0040h–0043h in program memory are reserved for code security passwords.

‡ When CNF = 1, addresses FE00h–FEFFh and FF00h–FFFFh are mapped to the same physical block (B0) in program-memory space. For example, a write to FE00h has the same effect as a write to FF00h. For simplicity, addresses FE00h–FEFFh are referred to as reserved.

§ When CNF = 0, addresses 0100h–01FFh and 0200h–02FFh are mapped to the same physical block (B0) in data-memory space. For example, a write to 0100h has the same effect as a write to 0200h. For simplicity, addresses 0100h–01FFh are referred to as reserved.

¶ Addresses 0300h–03FFh and 0400h–04FFh are mapped to the same physical block (B1) in data-memory space. For example, a write to 0400h has the same effect as a write to 0300h. For simplicity, addresses 0400h–04FFh are referred to as reserved.

Figure 7. TMS320LC2403A Memory Map

**TMS320LF2407A, TMS320LF2406A, TMS320LF2403A, TMS320LF2402A
TMS320LC2406A, TMS320LC2404A, TMS320LC2403A, TMS320LC2402A
DSP CONTROLLERS**

SPRS145L – JULY 2000 – REVISED SEPTEMBER 2007

memory maps (continued)

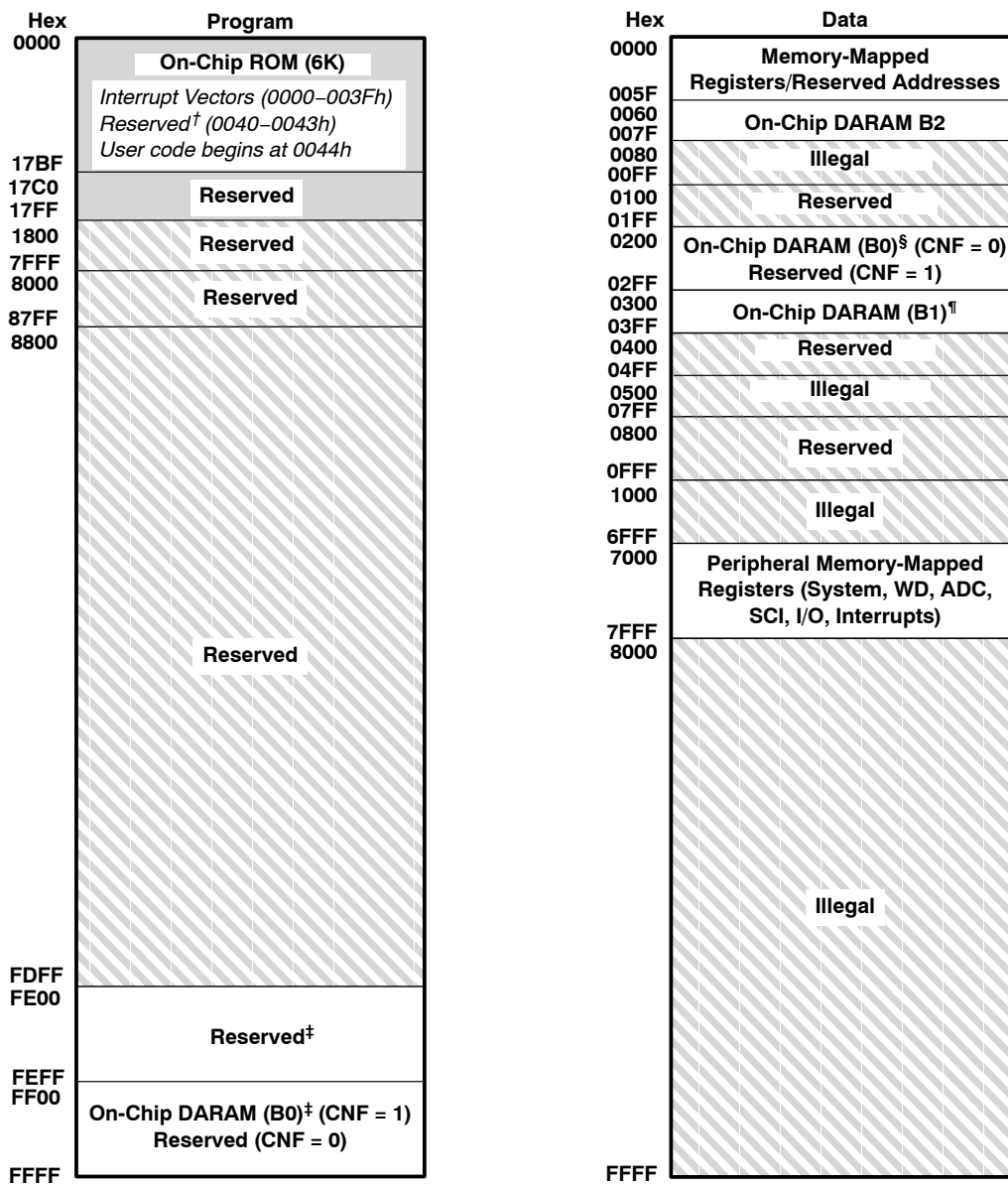

On-Chip ROM

Reserved or Illegal

† Addresses 0040h–0043h in program memory are reserved for code security passwords.

‡ When CNF = 1, addresses FE00h–FEFFh and FF00h–FFFFh are mapped to the same physical block (B0) in program-memory space. For example, a write to FE00h has the same effect as a write to FF00h. For simplicity, addresses FE00h–FEFFh are referred to as reserved.

§ When CNF = 0, addresses 0100h–01FFh and 0200h–02FFh are mapped to the same physical block (B0) in data-memory space. For example, a write to 0100h has the same effect as a write to 0200h. For simplicity, addresses 0100h–01FFh are referred to as reserved.

¶ Addresses 0300h–03FFh and 0400h–04FFh are mapped to the same physical block (B1) in data-memory space. For example, a write to 0400h has the same effect as a write to 0300h. For simplicity, addresses 0400h–04FFh are referred to as reserved.

Figure 8. TMS320LC2402A Memory Map

TMS320LF2407A, TMS320LF2406A, TMS320LF2403A, TMS320LF2402A TMS320LC2406A, TMS320LC2404A, TMS320LC2403A, TMS320LC2402A DSP CONTROLLERS

SPRS145L – JULY 2000 – REVISED SEPTEMBER 2007

peripheral memory map of the 2407A/2406A

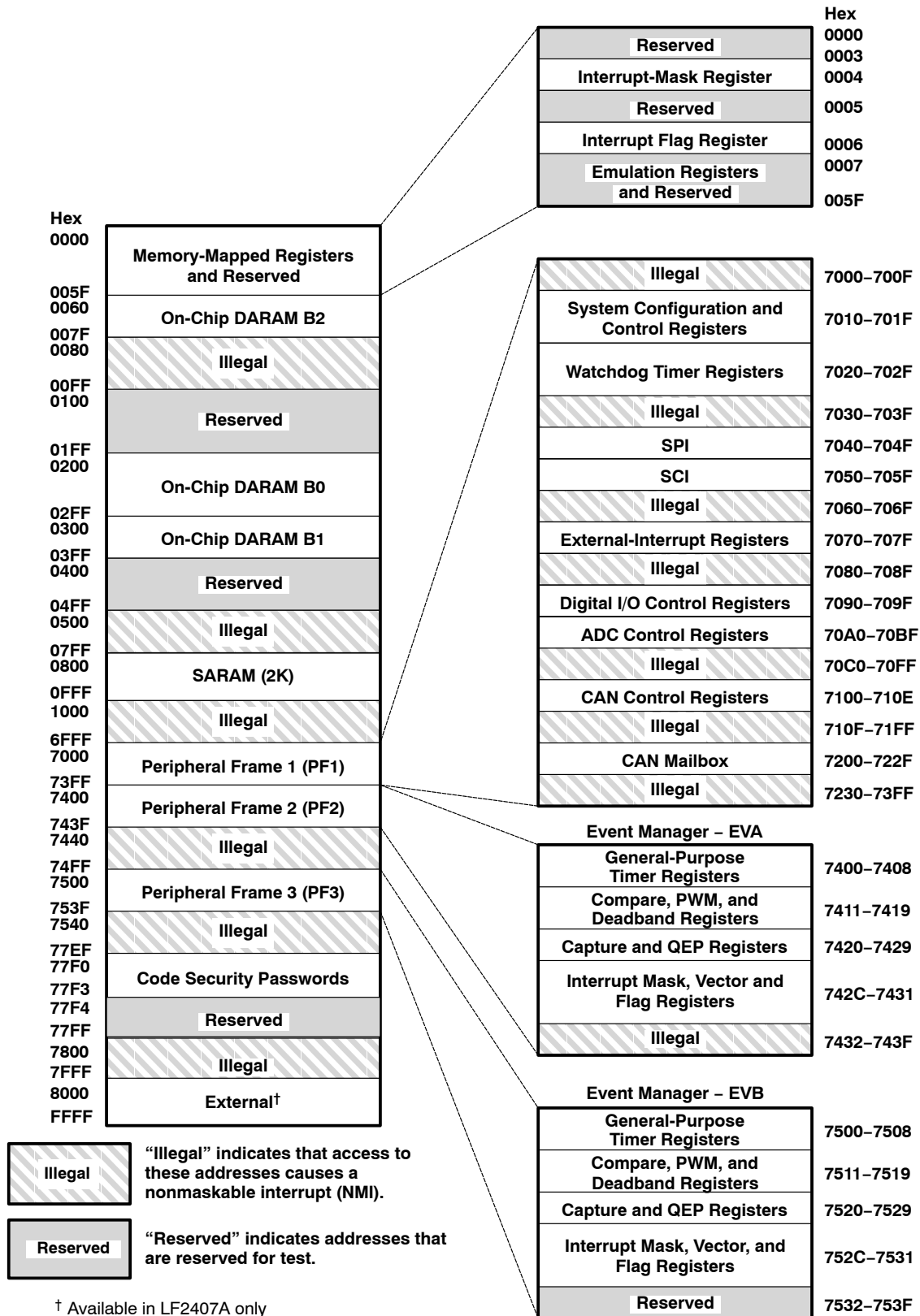

device reset and interrupts

The TMS320x240xA software-programmable interrupt structure supports flexible on-chip and external interrupt configurations to meet real-time interrupt-driven application requirements. The LF240xA recognizes three types of interrupt sources.

- **Reset** (hardware- or software-initiated) is unarbitrated by the CPU and takes immediate priority over any other executing functions. All maskable interrupts are disabled until the reset service routine enables them.

The LF240xA devices have two sources of reset: an external reset pin and a watchdog timer time-out (reset).

- **Hardware-generated interrupts** are requested by external pins or by on-chip peripherals. There are two types:
 - *External interrupts* are generated by one of four external pins corresponding to the interrupts XINT1, XINT2, PDPINTA, and PDPINTB. These four can be masked both by dedicated enable bits and by the CPU interrupt mask register (IMR), which can mask each maskable interrupt line at the DSP core.
 - *Peripheral interrupts* are initiated internally by these on-chip peripheral modules: event manager A, event manager B, SPI, SCI, CAN, and ADC. They can be masked both by enable bits for each event in each peripheral and by the CPU IMR, which can mask each maskable interrupt line at the DSP core.
- **Software-generated interrupts** for the LF240xA devices include:
 - *The INTR instruction.* This instruction allows initialization of any LF240xA interrupt with software. Its operand indicates the interrupt vector location to which the CPU branches. This instruction globally disables maskable interrupts (sets the INTM bit to 1).
 - *The NMI instruction.* This instruction forces a branch to interrupt vector location 24h. This instruction globally disables maskable interrupts. 240xA devices do not have the NMI hardware signal, only software activation is provided.
 - *The TRAP instruction.* This instruction forces the CPU to branch to interrupt vector location 22h. The TRAP instruction does *not* disable maskable interrupts (INTM is not set to 1); therefore, when the CPU branches to the interrupt service routine, that routine can be interrupted by the maskable hardware interrupts.
 - *An emulator trap.* This interrupt can be generated with either an INTR instruction or a TRAP instruction.

Six core interrupts (INT1–INT6) are expanded using a peripheral interrupt expansion (PIE) module identical to the F24x devices. The PIE manages all the peripheral interrupts from the 240xA peripherals and are grouped to share the six core level interrupts. Figure 9 shows the PIE block diagram for hardware-generated interrupts.

The PIE block diagram (Figure 9) and the interrupt table (Table 3) explain the grouping and interrupt vector maps. LF240xA devices have interrupts identical to those of the F24x devices and should be completely code-compatible. 240xA devices also have peripheral interrupts identical to those of the F24x – plus additional interrupts for new peripherals such as event manager B. Though the new interrupts share the 24x interrupt grouping, they all have a unique vector to differentiate among the interrupts. See Table 3 for details.

device reset and interrupts (continued)

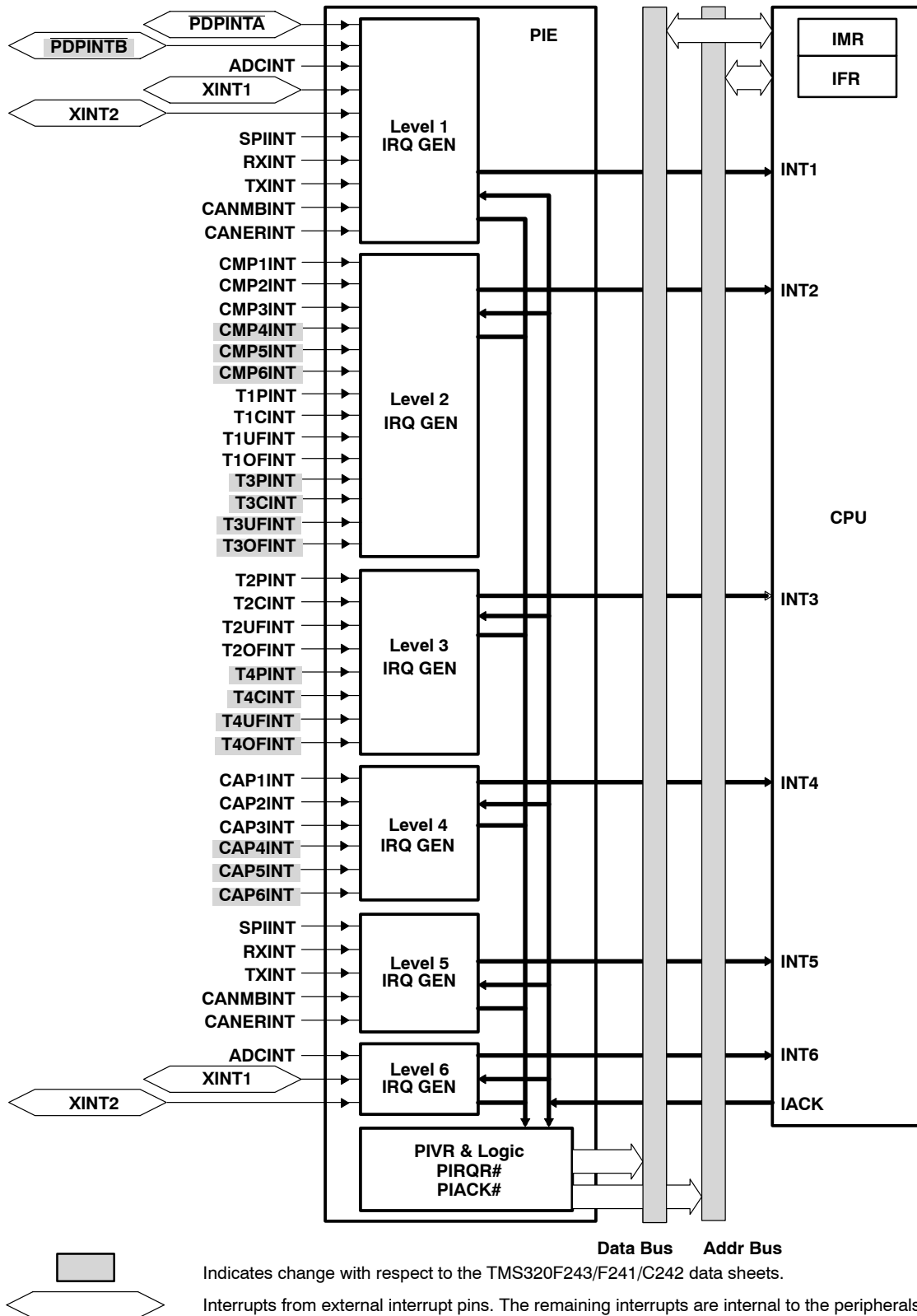

Figure 9. Peripheral Interrupt Expansion (PIE) Module Block Diagram for Hardware-Generated Interrupts

**TMS320LF2407A, TMS320LF2406A, TMS320LF2403A, TMS320LF2402A
TMS320LC2406A, TMS320LC2404A, TMS320LC2403A, TMS320LC2402A
DSP CONTROLLERS**

SPRS145L – JULY 2000 – REVISED SEPTEMBER 2007

interrupt request structure

Table 3. LF240xA/LC240xA Interrupt Source Priority and Vectors

INTERRUPT NAME	OVERALL PRIORITY	CPU INTERRUPT AND VECTOR ADDRESS	BIT POSITION IN PIRQRx AND PIACKRx	PERIPHERAL INTERRUPT VECTOR (PIV)	MASK-ABLE?	SOURCE PERIPHERAL MODULE	DESCRIPTION	
Reset	1	RSN 0000h		N/A	N	RS pin, Watchdog	Reset from pin, watchdog timeout	
Reserved	2	– 0026h		N/A	N	CPU	Emulator trap	
NMI	3	NMI 0024h		N/A	N	Nonmaskable Interrupt	Nonmaskable interrupt, software interrupt only	
PDPINTA	4	INT1 0002h	0.0	0020h	Y	EVA	Power device protection interrupt pins	
PDPINTB	5		2.0	0019h	Y	EVB		
ADCINT	6		0.1	0004h	Y	ADC	ADC interrupt in high-priority mode	
XINT1	7		0.2	0001h	Y	External Interrupt Logic	External interrupt pins in high priority	
XINT2	8		0.3	0011h	Y	External Interrupt Logic		
SPIINT	9		0.4	0005h	Y	SPI	SPI interrupt pins in high priority	
RXINT	10		0.5	0006h	Y	SCI	SCI receiver interrupt in high-priority mode	
TXINT	11		0.6	0007h	Y	SCI	SCI transmitter interrupt in high-priority mode	
CANMBINT	12		0.7	0040	Y	CAN	CAN mailbox in high-priority mode	
CANERINT	13		0.8	0041	Y	CAN	CAN error interrupt in high-priority mode	
CMP1INT	14		INT2 0004h	0.9	0021h	Y	EVA	Compare 1 interrupt
CMP2INT	15			0.10	0022h	Y	EVA	Compare 2 interrupt
CMP3INT	16			0.11	0023h	Y	EVA	Compare 3 interrupt
T1PINT	17			0.12	0027h	Y	EVA	Timer 1 period interrupt
T1CINT	18	0.13		0028h	Y	EVA	Timer 1 compare interrupt	
T1UFINT	19	0.14		0029h	Y	EVA	Timer 1 underflow interrupt	
T1OFINT	20	0.15		002Ah	Y	EVA	Timer 1 overflow interrupt	
CMP4INT	21	2.1		0024h	Y	EVB	Compare 4 interrupt	
CMP5INT	22	2.2		0025h	Y	EVB	Compare 5 interrupt	
CMP6INT	23	2.3		0026h	Y	EVB	Compare 6 interrupt	
T3PINT	24	2.4		002Fh	Y	EVB	Timer 3 period interrupt	
T3CINT	25	2.5		0030h	Y	EVB	Timer 3 compare interrupt	
T3UFINT	26	2.6		0031h	Y	EVB	Timer 3 underflow interrupt	
T3OFINT	27	2.7		0032h	Y	EVB	Timer 3 overflow interrupt	

† See the *TMS320LF/LC240xA DSP Controllers Reference Guide: System and Peripherals* (literature number SPRU357) for more information. NOTE: Some interrupts may not be available in a particular device due to the absence of a peripheral. See Table 1 for more details.

New peripheral interrupts and vectors with respect to the F243/F241 devices.



**TMS320LF2407A, TMS320LF2406A, TMS320LF2403A, TMS320LF2402A
TMS320LC2406A, TMS320LC2404A, TMS320LC2403A, TMS320LC2402A
DSP CONTROLLERS**

SPRS145L – JULY 2000 – REVISED SEPTEMBER 2007

interrupt request structure (continued)

Table 3. LF240xA/LC240xA Interrupt Source Priority and Vectors (Continued)

INTERRUPT NAME	OVERALL PRIORITY	CPU INTERRUPT AND VECTOR ADDRESS	BIT POSITION IN PIRQRx AND PIACKRx	PERIPHERAL INTERRUPT VECTOR (PIV)	MASK-ABLE?	SOURCE PERIPHERAL MODULE	DESCRIPTION
T2PINT	28	INT3 0006h	1.0	002Bh	Y	EVA	Timer 2 period interrupt
T2CINT	29		1.1	002Ch	Y	EVA	Timer 2 compare interrupt
T2UFINT	30		1.2	002Dh	Y	EVA	Timer 2 underflow interrupt
T2OFINT	31		1.3	002Eh	Y	EVA	Timer 2 overflow interrupt
T4PINT	32		2.8	0039h	Y	EVB	Timer 4 period interrupt
T4CINT	33		2.9	003Ah	Y	EVB	Timer 4 compare interrupt
T4UFINT	34		2.10	003Bh	Y	EVB	Timer 4 underflow interrupt
T4OFINT	35		2.11	003Ch	Y	EVB	Timer 4 overflow interrupt
CAP1INT	36		INT4 0008h	1.4	0033h	Y	EVA
CAP2INT	37	1.5		0034h	Y	EVA	Capture 2 interrupt
CAP3INT	38	1.6		0035h	Y	EVA	Capture 3 interrupt
CAP4INT	39	2.12		0036h	Y	EVB	Capture 4 interrupt
CAP5INT	40	2.13		0037h	Y	EVB	Capture 5 interrupt
CAP6INT	41	2.14		0038h	Y	EVB	Capture 6 interrupt
SPIINT	42	INT5 000Ah	1.7	0005h	Y	SPI	SPI interrupt (low priority)
RXINT	43		1.8	0006h	Y	SCI	SCI receiver interrupt (low-priority mode)
TXINT	44		1.9	0007h	Y	SCI	SCI transmitter interrupt (low-priority mode)
CANMBINT	45		1.10	0040h	Y	CAN	CAN mailbox interrupt (low-priority mode)
CANERINT	46		1.11	0041h	Y	CAN	CAN error interrupt (low-priority mode)
ADCINT	47	INT6 000Ch	1.12	0004h	Y	ADC	ADC interrupt (low priority)
XINT1	48		1.13	0001h	Y	External Interrupt Logic	External interrupt pins (low-priority mode)
XINT2	49		1.14	0011h	Y	External Interrupt Logic	
Reserved		000Eh		N/A	Y	CPU	Analysis interrupt
TRAP	N/A	0022h		N/A	N/A	CPU	TRAP instruction
Phantom Interrupt Vector	N/A	N/A		0000h	N/A	CPU	Phantom interrupt vector
INT8–INT16	N/A	0010h–0020h		N/A	N/A	CPU	Software interrupt vectors [†]
INT20–INT31	N/A	00028h–0003Fh		N/A	N/A	CPU	

[†] See the *TMS320LF/LC240xA DSP Controllers Reference Guide: System and Peripherals* (literature number SPRU357) for more information. NOTE: Some interrupts may not be available in a particular device due to the absence of a peripheral. See Table 1 for more details.

 New peripheral interrupts and vectors with respect to the F243/F241 devices.



TMS320LF2407A, TMS320LF2406A, TMS320LF2403A, TMS320LF2402A TMS320LC2406A, TMS320LC2404A, TMS320LC2403A, TMS320LC2402A DSP CONTROLLERS

SPRS145L – JULY 2000 – REVISED SEPTEMBER 2007

DSP CPU core

The TMS320x240xA devices use an advanced Harvard-type architecture that maximizes processing power by maintaining two separate memory bus structures — program and data — for full-speed execution. This multiple bus structure allows data and instructions to be read simultaneously. Instructions support data transfers between program memory and data memory. This architecture permits coefficients that are stored in program memory to be read in RAM, thereby eliminating the need for a separate coefficient ROM. This, coupled with a four-deep pipeline, allows the LF240xA/LC240xA devices to execute most instructions in a single cycle. See the functional block diagram of the 240xA DSP CPU for more information.

TMS320x240xA instruction set

The x240xA microprocessor implements a comprehensive instruction set that supports both numeric-intensive signal-processing operations and general-purpose applications, such as multiprocessing and high-speed control.

For maximum throughput, the next instruction is prefetched while the current one is being executed. Because the same data lines are used to communicate to external data, program, or I/O space, the number of cycles an instruction requires to execute varies, depending upon whether the next data operand fetch is from internal or external memory. Highest throughput is achieved by maintaining data memory on chip and using either internal or fast external program memory.

addressing modes

The TMS320x240xA instruction set provides four basic memory-addressing modes: direct, indirect, immediate, and register.

In direct addressing, the instruction word contains the lower seven bits of the data memory address. This field is concatenated with the nine bits of the data memory page pointer (DP) to form the 16-bit data memory address. Therefore, in the direct-addressing mode, data memory is paged effectively with a total of 512 pages, with each page containing 128 words.

Indirect addressing accesses data memory through the auxiliary registers. In this addressing mode, the address of the instruction operand is contained in the currently selected auxiliary register. Eight auxiliary registers (AR0–AR7) provide flexible and powerful indirect addressing. To select a specific auxiliary register, the auxiliary register pointer (ARP) is loaded with a value from 0 to 7 for AR0 through AR7, respectively.

scan-based emulation

TMS320x2xx devices incorporate scan-based emulation logic for code-development and hardware-development support. Scan-based emulation allows the emulator to control the processor in the system without the use of intrusive cables to the full pinout of the device. The scan-based emulator communicates with the x2xx by way of the IEEE 1149.1-compatible (JTAG) interface. The x240xA DSPs do not include boundary scan. The scan chain of these devices is useful for emulation function only.



TMS320LF2407A, TMS320LF2406A, TMS320LF2403A, TMS320LF2402A TMS320LC2406A, TMS320LC2404A, TMS320LC2403A, TMS320LC2402A DSP CONTROLLERS

SPRS145L – JULY 2000 – REVISED SEPTEMBER 2007

functional block diagram of the 2407A DSP CPU

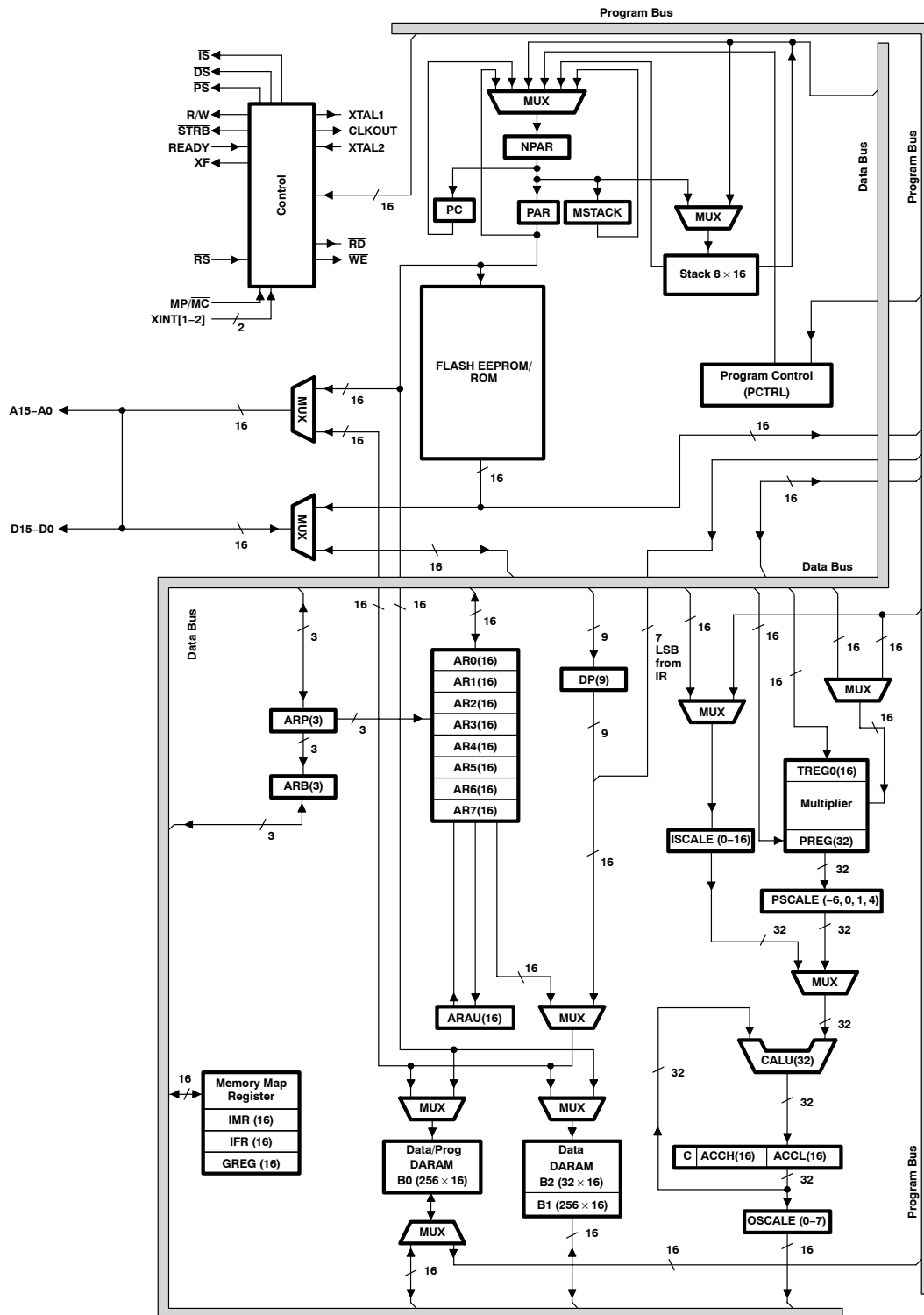

- NOTES: A. See Table 4 for symbol descriptions.
 B. For clarity, the data and program buses are shown as single buses although they include address and data bits.
 C. See the *TMS320F/C24x DSP Controllers Reference Guide: CPU and Instruction Set* (literature number SPRU160) for CPU instruction set information.



**TMS320LF2407A, TMS320LF2406A, TMS320LF2403A, TMS320LF2402A
TMS320LC2406A, TMS320LC2404A, TMS320LC2403A, TMS320LC2402A
DSP CONTROLLERS**

SPRS145L – JULY 2000 – REVISED SEPTEMBER 2007

240xA legend for the internal hardware

Table 4. Legend for the 240xA DSP CPU Internal Hardware

SYMBOL	NAME	DESCRIPTION
ACC	Accumulator	32-bit register that stores the results and provides input for subsequent CALU operations. Also includes shift and rotate capabilities
ARAU	Auxiliary Register Arithmetic Unit	An unsigned, 16-bit arithmetic unit used to calculate indirect addresses using the auxiliary registers as inputs and outputs
AUX REGS	Auxiliary Registers 0–7	These 16-bit registers are used as pointers to anywhere within the data space address range. They are operated upon by the ARAU and are selected by the auxiliary register pointer (ARP). AR0 can also be used as an index value for AR updates of more than one and as a compare value to AR.
C	Carry	Register carry output from CALU. C is fed back into the CALU for extended arithmetic operation. The C bit resides in status register 1 (ST1), and can be tested in conditional instructions. C is also used in accumulator shifts and rotates.
CALU	Central Arithmetic Logic Unit	32-bit-wide main arithmetic logic unit for the TMS320C2xx core. The CALU executes 32-bit operations in a single machine cycle. CALU operates on data coming from ISCALE or PSCALE with data from ACC, and provides status results to PCTRL.
DARAM	Dual-Access RAM	If the on-chip RAM configuration control bit (CNF) is set to 0, the reconfigurable data dual-access RAM (DARAM) block B0 is mapped to data space; otherwise, B0 is mapped to program space. Blocks B1 and B2 are mapped to data memory space only, at addresses 0300–03FF and 0060–007F, respectively. Blocks 0 and 1 contain 256 words, while block 2 contains 32 words.
DP	Data Memory Page Pointer	The 9-bit DP register is concatenated with the seven least significant bits (LSBs) of an instruction word to form a direct memory address of 16 bits. DP can be modified by the LST and LDP instructions.
GREG	Global Memory Allocation Register	GREG specifies the size of the global data memory space. Since the global memory space is not used in the 240xA devices, this register is reserved.
IMR	Interrupt Mask Register	IMR individually masks or enables the six core-level interrupts.
IFR	Interrupt Flag Register	The 6-bit IFR indicates that the TMS320Lx240xA has latched an interrupt from one of the six maskable interrupts.
INT#	Interrupt Traps	A total of 32 interrupts by way of hardware and/or software are available.
ISCALE	Input Data-Scaling Shifter	16- to 32-bit barrel left-shifter. ISCALE shifts incoming 16-bit data 0 to 16 positions left, relative to the 32-bit output within the fetch cycle; therefore, no cycle overhead is required for input scaling operations.
MPY	Multiplier	16 × 16-bit multiplier to a 32-bit product. MPY executes multiplication in a single cycle. MPY operates either signed or unsigned 2s-complement arithmetic multiply.
MSTACK	Micro Stack	MSTACK provides temporary storage for the address of the next instruction to be fetched when program address-generation logic is used to generate sequential addresses in data space.
MUX	Multiplexer	Multiplexes buses to a common input
NPAR	Next Program Address Register	NPAR holds the program address to be driven out on the PAB in the next cycle.
OSCALE	Output Data-Scaling Shifter	16- to 32-bit barrel left-shifter. OSCALE shifts the 32-bit accumulator output 0 to 7 bits left for quantization management and outputs either the 16-bit high- or low-half of the shifted 32-bit data to the data-write data bus (DWEB).
PAR	Program Address Register	PAR holds the address currently being driven on PAB for as many cycles as it takes to complete all memory operations scheduled for the current bus cycle.
PC	Program Counter	PC increments the value from NPAR to provide sequential addresses for instruction-fetching and sequential data-transfer operations.
PCTRL	Program Controller	PCTRL decodes instruction, manages the pipeline, stores status, and decodes conditional operations.



240xA legend for the internal hardware (continued)

Table 4. Legend for the 240xA DSP CPU Internal Hardware (Continued)

SYMBOL	NAME	DESCRIPTION
PREG	Product Register	32-bit register holds results of 16 × 16 multiply
PSCALE	Product-Scaling Shifter	0-, 1-, or 4-bit left shift, or 6-bit right shift of multiplier product. The left-shift options are used to manage the additional sign bits resulting from the 2s-complement multiply. The right-shift option is used to scale down the number to manage overflow of product accumulation in the CALU. PSCALE resides in the path from the 32-bit product shifter and from either the CALU or the data-write data bus (DWEB), and requires no cycle overhead.
STACK	Stack	STACK is a block of memory used for storing return addresses for subroutines and interrupt-service routines, or for storing data. The C2xx stack is 16 bits wide and 8 levels deep.
TREG	Temporary Register	16-bit register holds one of the operands for the multiply operations. TREG holds the dynamic shift count for the LACT, ADDT, and SUBT instructions. TREG holds the dynamic bit position for the BITT instruction.

status and control registers

Two status registers, ST0 and ST1, contain the status of various conditions and modes. These registers can be stored into data memory and loaded from data memory, thus allowing the status of the machine to be saved and restored for subroutines.

The load status register (LST) instruction is used to write to ST0 and ST1. The store status register (SST) instruction is used to read from ST0 and ST1 — except for the INTM bit, which is not affected by the LST instruction. The individual bits of these registers can be set or cleared when using the SETC and CLRC instructions. Figure 10 shows the organization of status registers ST0 and ST1, indicating all status bits contained in each. Several bits in the status registers are reserved and are read as logic 1s. Table 5 lists status register field definitions.

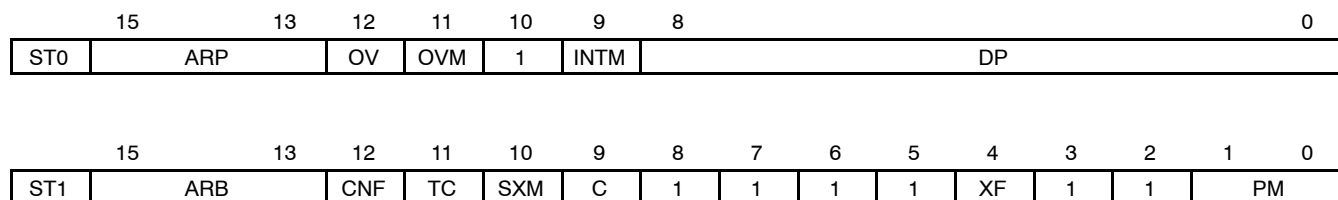

Figure 10. Organization of Status Registers ST0 and ST1

Table 5. Status Register Field Definitions

FIELD	FUNCTION
ARB	Auxiliary register pointer buffer. When the ARP is loaded into ST0, the old ARP value is copied to the ARB except during an LST instruction. When the ARB is loaded by way of an LST #1 instruction, the same value is also copied to the ARP.
ARP	Auxiliary register (AR) pointer. ARP selects the AR to be used in indirect addressing. When the ARP is loaded, the old ARP value is copied to the ARB register. ARP can be modified by memory-reference instructions when using indirect addressing, and by the LARP, MAR, and LST instructions. The ARP is also loaded with the same value as ARB when an LST #1 instruction is executed.
C	Carry bit. C is set to 1 if the result of an addition generates a carry, or reset to 0 if the result of a subtraction generates a borrow. Otherwise, C is reset after an addition or set after a subtraction, except if the instruction is ADD or SUB with a 16-bit shift. In these cases, ADD can only set and SUB can only reset the carry bit, but cannot affect it otherwise. The single-bit shift and rotate instructions also affect C, as well as the SETC, CLRC, and LST #1 instructions. Branch instructions have been provided to branch on the status of C. C is set to 1 on a reset.
CNF	On-chip RAM configuration control bit. If CNF is set to 0, the reconfigurable data dual-access RAM blocks are mapped to data space; otherwise, they are mapped to program space. The CNF can be modified by the SETC CNF, CLRC CNF, and LST #1 instructions. \overline{RS} sets the CNF to 0.

**TMS320LF2407A, TMS320LF2406A, TMS320LF2403A, TMS320LF2402A
TMS320LC2406A, TMS320LC2404A, TMS320LC2403A, TMS320LC2402A
DSP CONTROLLERS**

SPRS145L – JULY 2000 – REVISED SEPTEMBER 2007

status and control registers (continued)

Table 5. Status Register Field Definitions (Continued)

FIELD	FUNCTION
DP	Data memory page pointer. The 9-bit DP register is concatenated with the 7 LSBs of an instruction word to form a direct memory address of 16 bits. DP can be modified by the LST and LDP instructions.
INTM	Interrupt mode bit. When INTM is set to 0, all unmasked interrupts are enabled. When set to 1, all maskable interrupts are disabled. INTM is set and reset by the SETC INTM and CLRC INTM instructions. RS also sets INTM. INTM has no effect on the unmaskable RS and NMI interrupts. Note that INTM is unaffected by the LST instruction. This bit is set to 1 by reset. It is also set to 1 when a maskable interrupt trap is taken.
OV	Overflow flag bit. As a latched overflow signal, OV is set to 1 when overflow occurs in the arithmetic logic unit (ALU). Once an overflow occurs, the OV remains set until a reset, BCND/D on OV/NOV, or LST instruction clears OV.
OVM	Overflow mode bit. When OVM is set to 0, overflowed results overflow normally in the accumulator. When set to 1, the accumulator is set to either its most positive or negative value upon encountering an overflow. The SETC and CLRC instructions set and reset this bit, respectively. LST can also be used to modify the OVM.
PM	Product shift mode. If these two bits are 00, the multiplier's 32-bit product is loaded into the ALU with no shift. If PM = 01, the PREG output is left-shifted one place and loaded into the ALU, with the LSB zero-filled. If PM = 10, the PREG output is left-shifted by 4 bits and loaded into the ALU, with the LSBs zero-filled. PM = 11 produces a right shift of 6 bits, sign-extended. Note that the PREG contents remain unchanged. The shift takes place when transferring the contents of the PREG to the ALU. PM is loaded by the SPM and LST #1 instructions. PM is cleared by RS.
SXM	Sign-extension mode bit. SXM = 1 produces sign extension on data as it is passed into the accumulator through the scaling shifter. SXM = 0 suppresses sign extension. SXM does not affect the definitions of certain instructions; for example, the ADDS instruction suppresses sign extension regardless of SXM. SXM is set by the SETC SXM instruction and reset by the CLRC SXM instruction and can be loaded by the LST #1 instruction. SXM is set to 1 by reset.
TC	Test/control flag bit. TC is affected by the BIT, BITT, CMPR, LST #1, and NORM instructions. TC is set to a 1 if a bit tested by BIT or BITT is a 1, if a compare condition tested by CMPR exists between AR (ARP) and AR0, if the exclusive-OR function of the 2 most significant bits (MSBs) of the accumulator is true when tested by a NORM instruction. The conditional branch, call, and return instructions can execute based on the condition of TC.
XF	XF pin status bit. XF indicates the state of the XF pin, a general-purpose output pin. XF is set by the SETC XF instruction and reset by the CLRC XF instruction. XF is set to 1 by reset.

central processing unit

The TMS320x240xA central processing unit (CPU) contains a 16-bit scaling shifter, a 16 x 16-bit parallel multiplier, a 32-bit central arithmetic logic unit (CALU), a 32-bit accumulator, and additional shifters at the outputs of both the accumulator and the multiplier. This section describes the CPU components and their functions. The functional block diagram shows the components of the CPU.

input scaling shifter

The TMS320x240xA provides a scaling shifter with a 16-bit input connected to the data bus and a 32-bit output connected to the CALU. This shifter operates as part of the path of data coming from program or data space to the CALU and requires no cycle overhead. It is used to align the 16-bit data coming from memory to the 32-bit CALU. This is necessary for scaling arithmetic as well as aligning masks for logical operations.

The scaling shifter produces a left shift of 0 to 16 on the input data. The LSBs of the output are filled with zeros; the MSBs can either be filled with zeros or sign-extended, depending upon the value of the SXM bit (sign-extension mode) of status register ST1. The shift count is specified by a constant embedded in the instruction word or by a value in TREG. The shift count in the instruction allows for specific scaling or alignment operations specific to that point in the code. The TREG base shift allows the scaling factor to be adaptable to the system's performance.



multiplier

The TMS320x240xA devices use a 16 x 16-bit hardware multiplier that is capable of computing a signed or an unsigned 32-bit product in a single machine cycle. All multiply instructions, except the MPYU (multiply unsigned) instruction, perform a signed multiply operation. That is, two numbers being multiplied are treated as 2s-complement numbers, and the result is a 32-bit 2s-complement number. There are two registers associated with the multiplier, as follow:

- 16-bit temporary register (TREG) that holds one of the operands for the multiplier
- 32-bit product register (PREG) that holds the product

Four product-shift modes (PM) are available at the PREG output (PSCALE). These shift modes are useful for performing multiply/accumulate operations, performing fractional arithmetic, or justifying fractional products. The PM field of status register ST1 specifies the PM shift mode, as shown in Table 6.

Table 6. PSCALE Product-Shift Modes

PM	SHIFT	DESCRIPTION
00	No shift	Product feed to CALU or data bus with no shift
01	Left 1	Removes the extra sign bit generated in a 2s-complement multiply to produce a Q31 product
10	Left 4	Removes the extra 4 sign bits generated in a 16x13 2s-complement multiply to a produce a Q31 product when using the multiply-by-a-13-bit constant
11	Right 6	Scales the product to allow up to 128 product accumulation without the possibility of accumulator overflow

The product can be shifted one bit to compensate for the extra sign bit gained in multiplying two 16-bit 2s-complement numbers (MPY instruction). A four-bit shift is used in conjunction with the MPY instruction with a short immediate value (13 bits or less) to eliminate the four extra sign bits gained in multiplying a 16-bit number by a 13-bit number. Finally, the output of PREG can be right-shifted 6 bits to enable the execution of up to 128 consecutive multiply/accumulates without the possibility of overflow.

The LT (load TREG) instruction normally loads TREG to provide one operand (from the data bus), and the MPY (multiply) instruction provides the second operand (also from the data bus). A multiplication also can be performed with a 13-bit immediate operand when using the MPY instruction. Then, a product is obtained every two cycles. When the code is executing multiple multiplies and product sums, the CPU supports the pipelining of the TREG load operations with CALU operations using the previous product. The pipeline operations that run in parallel with loading the TREG include: load ACC with PREG (LTP); add PREG to ACC (LTA); add PREG to ACC and shift TREG input data (DMOV) to next address in data memory (LTD); and subtract PREG from ACC (LTS).

Two multiply/accumulate instructions (MAC and MACD) fully utilize the computational bandwidth of the multiplier, allowing both operands to be processed simultaneously. The data for these operations can be transferred to the multiplier each cycle by way of the program and data buses. This facilitates single-cycle multiply/accumulates when used with the repeat (RPT) instruction. In these instructions, the coefficient addresses are generated by program address generation (PAGEN) logic, while the data addresses are generated by data address generation (DAGEN) logic. This allows the repeated instruction to access the values from the coefficient table sequentially and step through the data in any of the indirect addressing modes.

The MACD instruction, when repeated, supports filter constructs (weighted running averages) so that as the sum-of-products is executed, the sample data is shifted in memory to make room for the next sample and to throw away the oldest sample.

TMS320LF2407A, TMS320LF2406A, TMS320LF2403A, TMS320LF2402A TMS320LC2406A, TMS320LC2404A, TMS320LC2403A, TMS320LC2402A DSP CONTROLLERS

SPRS145L – JULY 2000 – REVISED SEPTEMBER 2007

multiplier (continued)

The MPYU instruction performs an unsigned multiplication, which greatly facilitates extended-precision arithmetic operations. The unsigned contents of TREG are multiplied by the unsigned contents of the addressed data memory location, with the result placed in PREG. This process allows the operands of greater than 16 bits to be broken down into 16-bit words and processed separately to generate products of greater than 32 bits. The SQRA (square/add) and SQRS (square/subtract) instructions pass the same value to both inputs of the multiplier for squaring a data memory value.

After the multiplication of two 16-bit numbers, the 32-bit product is loaded into the 32-bit product register (PREG). The product from PREG can be transferred to the CALU or to data memory by way of the SPH (store product high) and SPL (store product low) instructions. Note: the transfer of PREG to either the CALU or data bus passes through the PSCALE shifter, and therefore is affected by the product shift mode defined by PM. This is important when saving PREG in an interrupt-service-routine context save as the PSCALE shift effects cannot be modeled in the restore operation. PREG can be cleared by executing the MPY #0 instruction. The product register can be restored by loading the saved low half into TREG and executing a MPY #1 instruction. The high half, then, is loaded using the LPH instruction.

central arithmetic logic unit

The TMS320x240xA central arithmetic logic unit (CALU) implements a wide range of arithmetic and logical functions, the majority of which execute in a single clock cycle. This ALU is referred to as central to differentiate it from a second ALU used for indirect-address generation called the auxiliary register arithmetic unit (ARAU). Once an operation is performed in the CALU, the result is transferred to the accumulator (ACC) where additional operations, such as shifting, can occur. Data that is input to the CALU can be scaled by ISCALE when coming from one of the data buses (DRDB or PRDB) or scaled by PSCALE when coming from the multiplier.

The CALU is a general-purpose ALU that operates on 16-bit words taken from data memory or derived from immediate instructions. In addition to the usual arithmetic instructions, the CALU can perform Boolean operations, facilitating the bit-manipulation ability required for a high-speed controller. One input to the CALU is always provided from the accumulator, and the other input can be provided from the product register (PREG) of the multiplier or the output of the scaling shifter (that has been read from data memory or from the ACC). After the CALU has performed the arithmetic or logical operation, the result is stored in the accumulator.

The TMS320x240xA devices support floating-point operations for applications requiring a large dynamic range. The NORM (normalization) instruction is used to normalize fixed-point numbers contained in the accumulator by performing left shifts. The four bits of the TREG define a variable shift through the scaling shifter for the LACT/ADDT/SUBT (load/add to/subtract from accumulator with shift specified by TREG) instructions. These instructions are useful in floating-point arithmetic where a number needs to be denormalized — that is, floating-point to fixed-point conversion. They are also useful in the execution of an automatic gain control (AGC) going into a filter. The BITT (bit test) instruction provides testing of a single bit of a word in data memory based on the value contained in the four LSBs of TREG.

The CALU overflow saturation mode can be enabled/disabled by setting/resetting the OVM bit of ST0. When the CALU is in the overflow saturation mode and an overflow occurs, the overflow flag is set and the accumulator is loaded with either the most positive or the most negative value representable in the accumulator, depending on the direction of the overflow. The value of the accumulator at saturation is 07FFFFFFh (positive) or 08000000h (negative). If the OVM (overflow mode) status register bit is reset and an overflow occurs, the overflowed results are loaded into the accumulator with modification. (Note that logical operations cannot result in overflow.)

The CALU can execute a variety of branch instructions that depend on the status of the CALU and the accumulator. These instructions can be executed conditionally based on any meaningful combination of these status bits. For overflow management, these conditions include OV (branch on overflow) and EQ (branch on accumulator equal to zero). In addition, the BACC (branch to address in accumulator) instruction provides the ability to branch to an address specified by the accumulator (computed goto). Bit test instructions (BIT and BITT), which do not affect the accumulator, allow the testing of a specified bit of a word in data memory.



central arithmetic logic unit (continued)

The CALU also has an associated carry bit that is set or reset depending on various operations within the device. The carry bit allows more efficient computation of extended-precision products and additions or subtractions. It is also useful in overflow management. The carry bit is affected by most arithmetic instructions as well as the single-bit shift and rotate instructions. It is not affected by loading the accumulator, logical operations, or other such non-arithmetic or control instructions.

The ADDC (add to accumulator with carry) and SUBB (subtract from accumulator with borrow) instructions use the previous value of carry in their addition/subtraction operation.

The one exception to the operation of the carry bit is in the use of ADD with a shift count of 16 (add to high accumulator) and SUB with a shift count of 16 (subtract from high accumulator) instructions. This case of the ADD instruction can set the carry bit only if a carry is generated, and this case of the SUB instruction can reset the carry bit only if a borrow is generated; otherwise, neither instruction affects it.

Two conditional operands, C and NC, are provided for branching, calling, returning, and conditionally executing, based upon the status of the carry bit. The SETC, CLRC, and LST #1 instructions also can be used to load the carry bit. The carry bit is set to one on a hardware reset.

accumulator

The 32-bit accumulator is the registered output of the CALU. It can be split into two 16-bit segments for storage in data memory. Shifters at the output of the accumulator provide a left shift of 0 to 7 places. This shift is performed while the data is being transferred to the data bus for storage. The contents of the accumulator remain unchanged. When the postscaling shifter is used on the high word of the accumulator (bits 16–31), the MSBs are lost and the LSBs are filled with bits shifted in from the low word (bits 0–15). When the postscaling shifter is used on the low word, the LSBs are zero-filled.

The SFL and SFR (in-place one-bit shift to the left/right) instructions and the ROL and ROR (rotate to the left/right) instructions implement shifting or rotating of the contents of the accumulator through the carry bit. The SXM bit affects the definition of the SFR (shift accumulator right) instruction. When SXM = 1, SFR performs an arithmetic right shift, maintaining the sign of the accumulator data. When SXM = 0, SFR performs a logical shift, shifting out the LSBs and shifting in a zero for the MSB. The SFL (shift accumulator left) instruction is not affected by the SXM bit and behaves the same in both cases, shifting out the MSB and shifting in a zero. Repeat (RPT) instructions can be used with the shift and rotate instructions for multiple-bit shifts.

auxiliary registers and auxiliary-register arithmetic unit (ARAU)

The 240xA provides a register file containing eight auxiliary registers (AR0–AR7). The auxiliary registers are used for indirect addressing of the data memory or for temporary data storage. Indirect auxiliary-register addressing allows placement of the data memory address of an instruction operand into one of the auxiliary registers. These registers are referenced with a 3-bit auxiliary register pointer (ARP) that is loaded with a value from 0 through 7, designating AR0 through AR7, respectively. The auxiliary registers and the ARP can be loaded from data memory, the ACC, the product register, or by an immediate operand defined in the instruction. The contents of these registers also can be stored in data memory or used as inputs to the CALU.

The auxiliary register file (AR0–AR7) is connected to the ARAU. The ARAU can autoindex the current auxiliary register while the data memory location is being addressed. Indexing either by ± 1 or by the contents of the AR0 register can be performed. As a result, accessing tables of information does not require the CALU for address manipulation; therefore, the CALU is free for other operations in parallel.

TMS320LF2407A, TMS320LF2406A, TMS320LF2403A, TMS320LF2402A TMS320LC2406A, TMS320LC2404A, TMS320LC2403A, TMS320LC2402A DSP CONTROLLERS

SPRS145L – JULY 2000 – REVISED SEPTEMBER 2007

internal memory

The TMS320x240xA devices are configured with the following memory modules:

- Dual-access random-access memory (DARAM)
- Single-access random-access memory (SARAM)
- Flash
- ROM
- Boot ROM

dual-access RAM (DARAM)

There are 544 words \times 16 bits of DARAM on the 240xA devices. The 240xA DARAM allows writes to and reads from the RAM in the same cycle. The DARAM is configured in three blocks: block 0 (B0), block 1 (B1), and block 2 (B2). Block 1 contains 256 words and Block 2 contains 32 words, and both blocks are located only in data memory space. Block 0 contains 256 words, and can be configured to reside in either data or program memory space. The SETC CNF (configure B0 as program memory) and CLRC CNF (configure B0 as data memory) instructions allow dynamic configuration of the memory maps through software.

When using on-chip RAM, the 240xA runs at full speed with no wait states. The ability of the DARAM to allow two accesses to be performed in one cycle, coupled with the parallel nature of the 240xA architecture, enables the device to perform three concurrent memory accesses in any given machine cycle. Externally, the READY line or on-chip software wait-state generator can be used to interface the 2407A to slower, less expensive external memory.

single-access RAM (SARAM)

There are 2K words \times 16 bits of SARAM on some of the 240xA devices.[†] The PON and DON bits select SARAM (2K) mapping in program space, data space, or both. See Table 19 for details on the SCSR2 register and the PON and DON bits. At reset, these bits are 11, and the on-chip SARAM is mapped in both the program and data spaces. The SARAM (starting at 8000h in program memory) is accessible in external memory space (for 2407A only), if the on-chip SARAM is not enabled.

flash EEPROM

Flash EEPROM provides an attractive alternative to masked program ROM. Like ROM, Flash is nonvolatile. However, it has the advantage of “in-target” reprogrammability. The LF2407A incorporates one 32K \times 16-bit Flash EEPROM module in program space. The Flash module has multiple sectors that can be individually protected while erasing or programming. The sector size is non-uniform and partitioned as 4K/12K/12K/4K sectors.

Unlike most discrete Flash memory, the LF240xA Flash does not require a dedicated state machine, because the algorithms for programming and erasing the Flash are executed by the DSP core. This enables several advantages, including: reduced chip size and sophisticated, adaptive algorithms. For production programming, the IEEE Standard 1149.1[‡] (JTAG) scan port provides easy access to the on-chip RAM for downloading the algorithms and Flash code. This Flash requires 5 V for programming (at V_{CCP} pin only) the array. The Flash runs at zero wait state while the device is powered at 3.3 V.

ROM

The LC240xA devices contain mask-programmable ROM located in program memory space. Customers can arrange to have this ROM programmed with contents unique to any particular application. See Table 1 for the ROM memory capacity of each LC240xA device.

[†] See Table 1 for device-specific features.

[‡] IEEE Standard 1149.1–1990, IEEE Standard Test Access Port.

boot ROM (LF240xA only)

Boot ROM is a 256-word ROM memory-mapped in program space 0000–00FF. This ROM will be enabled if the `BOOT_EN` pin is low during reset. The `BOOT_EN` bit (bit 3 of the `SCSR2` register) will be set to 0 if the `BOOT_EN` pin is low at reset. Boot ROM can also be enabled by writing 0 to the `SCSR2.3` bit and disabled by writing 1 to this bit.

The boot ROM has a generic bootloader to transfer code through SCI or SPI ports. The incoming code should disable the `BOOT_ROM` bit by writing 1 to bit 3 of the `SCSR2` register, or else, the whole Flash array will not be enabled.

The boot ROM code sets the PLL to x2 or x4 option based on the condition of the `SCITXD` pin during reset. The `SCITXD` pin should be pulled high/low to select the PLL multiplication factor. The choices made are as follows:

- If the `SCITXD` pin is pulled low, the PLL multiplier is set to 2.
- If the `SCITXD` pin is pulled high, the PLL multiplier is set to 4. (Default)
- If the `SCITXD` pin is not driven at reset, the internal pullup selects the default multiplier of 4.

Care should be taken such that a combination of `CLKIN` and the PLL multiplication factor should not result in a CPU clock speed of greater than 40 MHz, the maximum rated speed.

Furthermore, when the bootloader is used, only specific values of `CLKIN` would result in a baud-lock for the SCI. See the *TMS320LF/LC240xA DSP Controllers Reference Guide: System and Peripherals* (literature number SPRU357) for more details about the bootloader operation.

flash/ROM security

240xA devices incorporate a security feature that prevents external access to program memory. This feature is useful in preventing unauthorized duplication of proprietary code.

If access to Flash/ROM contents are desired for debugging purposes, two actions need to be taken:

1. A “dummy” read of locations 40h, 41h, 42h and 43h (of program memory space) is necessary. The word “dummy” indicates that the destination address of this read is insignificant.

NOTE: Step 2 is not required if 40h–43h contain 0000 0000 0000 0000h or FFFF FFFF FFFF FFFFh.

2. A 64-bit password (split as four 16-bit words) must be written to the data-memory locations 77F0h, 77F1h, 77F2h, and 77F3h. The four 16-bit words written to these locations must match the four words stored in 40h, 41h, 42h, and 43h (of program memory space), respectively. The device becomes “unsecured” one cycle after the last instruction that unsecures the part.

Code Security Module Disclaimer

The Code Security Module (“CSM”) included on this device was designed to password protect the data stored in the associated memory (either ROM or Flash) and is warranted by Texas Instruments (TI), in accordance with its standard terms and conditions, to conform to TI’s published specifications for the warranty period applicable for this device.

TI DOES NOT, HOWEVER, WARRANT OR REPRESENT THAT THE CSM CANNOT BE COMPROMISED OR BREACHED OR THAT THE DATA STORED IN THE ASSOCIATED MEMORY CANNOT BE ACCESSED THROUGH OTHER MEANS. MOREOVER, EXCEPT AS SET FORTH ABOVE, TI MAKES NO WARRANTIES OR REPRESENTATIONS CONCERNING THE CSM OR OPERATION OF THIS DEVICE, INCLUDING ANY IMPLIED WARRANTIES OF MERCHANTABILITY OR FITNESS FOR A PARTICULAR PURPOSE.

**TMS320LF2407A, TMS320LF2406A, TMS320LF2403A, TMS320LF2402A
TMS320LC2406A, TMS320LC2404A, TMS320LC2403A, TMS320LC2402A
DSP CONTROLLERS**

SPRS145L - JULY 2000 - REVISED SEPTEMBER 2007

IN NO EVENT SHALL TI BE LIABLE FOR ANY CONSEQUENTIAL, SPECIAL, INDIRECT, INCIDENTAL, OR PUNITIVE DAMAGES, HOWEVER CAUSED, ARISING IN ANY WAY OUT OF YOUR USE OF THE CSM OR THIS DEVICE, WHETHER OR NOT TI HAS BEEN ADVISED OF THE POSSIBILITY OF SUCH DAMAGES. EXCLUDED DAMAGES INCLUDE, BUT ARE NOT LIMITED TO LOSS OF DATA, LOSS OF GOODWILL, LOSS OF USE OR INTERRUPTION OF BUSINESS OR OTHER ECONOMIC LOSS.



PERIPHERALS

The integrated peripherals of the TMS320x240xA are described in the following subsections:

- Two event-manager modules (EVA, EVB)
- Enhanced analog-to-digital converter (ADC) module
- Controller area network (CAN) module
- Serial communications interface (SCI) module
- Serial peripheral interface (SPI) module
- PLL-based clock module
- Digital I/O and shared pin functions
- External memory interfaces (LF2407A only)
- Watchdog (WD) timer module

event manager modules (EVA, EVB)

The event-manager modules include general-purpose (GP) timers, full-compare/PWM units, capture units, and quadrature-encoder pulse (QEP) circuits. EVA and EVB timers, compare units, and capture units function identically. However, timer/unit names differ for EVA and EVB. Table 7 shows the module and signal names used. Table 7 shows the features and functionality available for the event-manager modules and highlights EVA nomenclature.

Event managers A and B have identical peripheral register sets with EVA starting at 7400h and EVB starting at 7500h. The paragraphs in this section describe the function of GP timers, compare units, capture units, and QEPs using EVA nomenclature. These paragraphs are applicable to EVB with regard to function—however, module/signal names would differ.

Table 7. Module and Signal Names for EVA and EVB

EVENT MANAGER MODULES	EVA		EVB	
	MODULE	SIGNAL	MODULE	SIGNAL
GP Timers	Timer 1 Timer 2	T1PWM/T1CMP T2PWM/T2CMP	Timer 3 Timer 4	T3PWM/T3CMP T4PWM/T4CMP
Compare Units	Compare 1 Compare 2 Compare 3	PWM1/2 PWM3/4 PWM5/6	Compare 4 Compare 5 Compare 6	PWM7/8 PWM9/10 PWM11/12
Capture Units	Capture 1 Capture 2 Capture 3	CAP1 CAP2 CAP3	Capture 4 Capture 5 Capture 6	CAP4 CAP5 CAP6
QEP	QEP1 QEP2	QEP1 QEP2	QEP3 QEP4	QEP3 QEP4
External Inputs	Direction External Clock	TDIRA TCLKINA	Direction External Clock	TDIRB TCLKINB

**TMS320LF2407A, TMS320LF2406A, TMS320LF2403A, TMS320LF2402A
TMS320LC2406A, TMS320LC2404A, TMS320LC2403A, TMS320LC2402A
DSP CONTROLLERS**

SPRS145L – JULY 2000 – REVISED SEPTEMBER 2007

event manager modules (EVA, EVB) (continued)

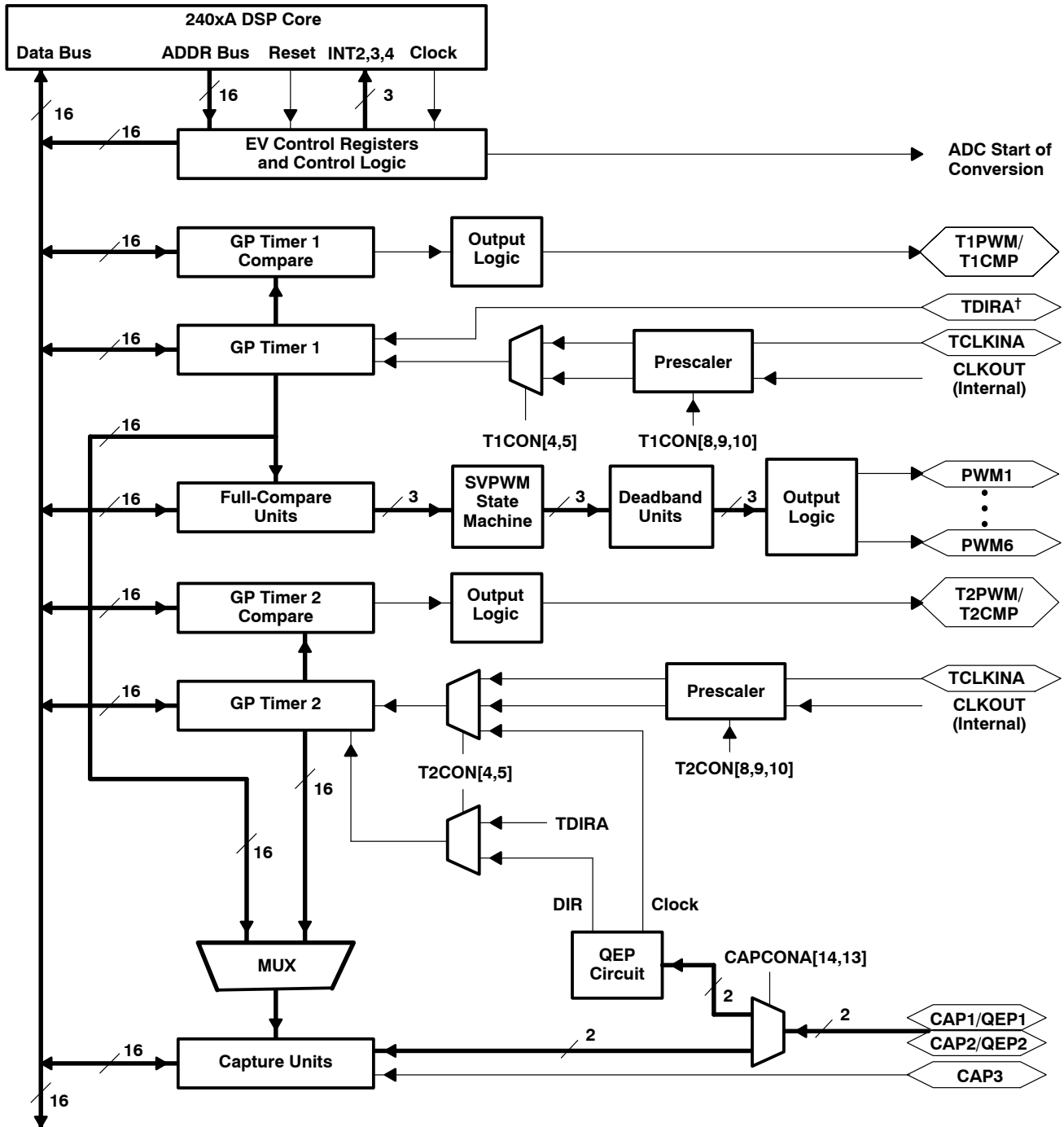

† 2402A devices do not support external direction control. TDIR is not available.

Figure 11. Event Manager A Block Diagram

general-purpose (GP) timers

There are two GP timers. The GP timer x (x = 1 or 2 for EVA; x = 3 or 4 for EVB) includes:

- A 16-bit timer, up-/down-counter, TxCNT, for reads or writes
- A 16-bit timer-compare register, TxCMPR (double-buffered with shadow register), for reads or writes
- A 16-bit timer-period register, TxPR (double-buffered with shadow register), for reads or writes
- A 16-bit timer-control register, TxCON, for reads or writes
- Selectable internal or external input clocks
- A programmable prescaler for internal or external clock inputs
- Control and interrupt logic, for four maskable interrupts: *underflow*, *overflow*, *timer compare*, and *period interrupts*
- A selectable direction input pin (TDIRx) (to count up or down when directional up-/down-count mode is selected)

The GP timers can be operated independently or synchronized with each other. The compare register associated with each GP timer can be used for compare function and PWM-waveform generation. There are three continuous modes of operations for each GP timer in up- or up/down-counting operations. Internal or external input clocks with programmable prescaler are used for each GP timer. GP timers also provide the time base for the other event-manager submodules: GP timer 1 for all the compares and PWM circuits, GP timer 2/1 for the capture units and the quadrature-pulse counting operations. Double-buffering of the period and compare registers allows programmable change of the timer (PWM) period and the compare/PWM pulse width as needed.

full-compare units

There are three full-compare units on each event manager. These compare units use GP timer1 as the time base and generate six outputs for compare and PWM-waveform generation using programmable deadband circuit. The state of each of the six outputs is configured independently. The compare registers of the compare units are double-buffered, allowing programmable change of the compare/PWM pulse widths as needed.

programmable deadband generator

The deadband generator circuit includes three 8-bit counters and an 8-bit compare register. Desired deadband values (from 0 to 16 μ s) can be programmed into the compare register for the outputs of the three compare units. The deadband generation can be enabled/disabled for each compare unit output individually. The deadband-generator circuit produces two outputs (with or without deadband zone) for each compare unit output signal. The output states of the deadband generator are configurable and changeable as needed by way of the double-buffered ACTR register.

PWM waveform generation

Up to eight PWM waveforms (outputs) can be generated simultaneously by each event manager: three independent pairs (six outputs) by the three full-compare units with *programmable deadbands*, and two independent PWMs by the GP-timer compares.

TMS320LF2407A, TMS320LF2406A, TMS320LF2403A, TMS320LF2402A TMS320LC2406A, TMS320LC2404A, TMS320LC2403A, TMS320LC2402A DSP CONTROLLERS

SPRS145L – JULY 2000 – REVISED SEPTEMBER 2007

PWM characteristics

Characteristics of the PWMs are as follows:

- 16-bit registers
- Programmable deadband for the PWM output pairs, from 0 to 12 μ s
- Minimum deadband width of 25 ns
- Change of the PWM carrier frequency for PWM frequency wobbling as needed
- Change of the PWM pulse widths within and after each PWM period as needed
- External-maskable power and drive-protection interrupts
- Pulse-pattern-generator circuit, for programmable generation of asymmetric, symmetric, and four-space vector PWM waveforms
- Minimized CPU overhead using auto-reload of the compare and period registers
- The PWM pins are driven to a high-impedance state when the $\overline{\text{PDPINTx}}$ pin is driven low and **after** $\overline{\text{PDPINTx}}$ signal qualification. The $\overline{\text{PDPINTx}}$ pin (after qualification) is reflected in bit 8 of the COMCONx register.
 - $\overline{\text{PDPINTA}}$ pin status is reflected in bit 8 of COMCONA register.
 - $\overline{\text{PDPINTB}}$ pin status is reflected in bit 8 of COMCONB register.

capture unit

The capture unit provides a logging function for different events or transitions. The values of the selected GP timer counter is captured and stored in the two-level-deep FIFO stacks when selected transitions are detected on capture input pins, CAPx (x = 1, 2, or 3 for EVA; and x = 4, 5, or 6 for EVB). The capture unit consists of three capture circuits.

Capture units include the following features:

- One 16-bit capture control register, CAPCONx (R/W)
- One 16-bit capture FIFO status register, CAPFIFOx
- Selection of GP timer 1/2 (for EVA) or 3/4 (for EVB) as the time base
- Three 16-bit 2-level-deep FIFO stacks, one for each capture unit
- Three capture input pins (CAP1/2/3 for EVA, CAP4/5/6 for EVB)—one input pin per capture unit. [All inputs are synchronized with the device (CPU) clock. In order for a transition to be captured, the input must hold at its current level to meet two rising edges of the device clock. The input pins CAP1/2 and CAP4/5 can also be used as QEP inputs to the QEP circuit.]
- User-specified transition (rising edge, falling edge, or both edges) detection
- Three maskable interrupt flags, one for each capture unit

quadrature-encoder pulse (QEP) circuit

Two capture inputs (CAP1 and CAP2 for EVA; CAP4 and CAP5 for EVB) can be used to interface the on-chip QEP circuit with a quadrature encoder pulse. Full synchronization of these inputs is performed on-chip. Direction or leading-quadrature pulse sequence is detected, and GP timer 2/4 is incremented or decremented by the rising and falling edges of the two input signals (four times the frequency of either input pulse).



input qualifier circuitry

An input-qualifier circuitry qualifies the input signal to the CAP1–6, QEP1–4, XINT1/2, ADCSOC and $\overline{\text{PDPINTA/B}}$ pins in the 240xA devices. (The I/O functions of these pins do not use the input-qualifier circuitry). The state of the internal input signal will change only after the pin is high/low for 6(12) clock edges. This ensures that a glitch smaller than 5(11) CLKOUT cycles wide will not change the internal pin input state. The user must hold the pin high/low for 6(12) cycles to ensure the device will see the level change. Bit 6 of the SCSR2 register controls whether 6 clock edges (bit 6 = 0) or 12 clock edges (bit 6 = 1) are used to block 5- or 11-cycle glitches. On the LC2402A, input qualification is for the CAP1, CAP2, CAP3, $\overline{\text{PDPINTA}}$, and XINT2/ADCSOC pins.

enhanced analog-to-digital converter (ADC) module

A simplified functional block diagram of the ADC module is shown in Figure 12. The ADC module consists of a 10-bit ADC with a built-in sample-and-hold (S/H) circuit. Functions of the ADC module include:

- 10-bit ADC core with built-in S/H
- 16-channel, MUXed inputs
- Autosequencing capability provides up to 16 “autoconversions” in a single session. Each conversion can be programmed to select any 1 of 16 input channels
- Sequencer can be operated as two independent 8-state sequencers or as one large 16-state sequencer (i.e., two cascaded 8-state sequencers)
- Sixteen result registers (individually addressable) to store conversion values

- The digital value of the input analog voltage is derived by:

$$\text{Digital Value} = 0 \qquad \text{when input} \leq V_{\text{REFLO}}$$

$$\text{Digital Value} = 1024 \times \frac{\text{Input Analog Voltage} - V_{\text{REFLO}}}{V_{\text{REFHI}} - V_{\text{REFLO}}} \qquad \text{when } V_{\text{REFLO}} < \text{input} < V_{\text{REFHI}}$$

$$\text{Digital Value} = 1023 \qquad \text{when input} \geq V_{\text{REFHI}}$$

Note: All fractional values are truncated.

- Multiple triggers as sources for the start-of-conversion (SOC) sequence
 - S/W – software immediate start
 - EVA – Event manager A (multiple event sources within EVA)
 - EVB – Event manager B (multiple event sources within EVB)
 - Ext – External pin (ADCSOC)
- Flexible interrupt control allows interrupt request on every end-of-sequence (EOS) or every other EOS
- Sequencer can operate in “start/stop” mode, allowing multiple “time-sequenced triggers” to synchronize conversions
- EVA and EVB triggers can operate independently in dual-sequencer mode
- Sample-and-hold (S/H) acquisition time window has separate prescale control

NOTE: The calibration and self-test features are not present in 240xA devices.

enhanced analog-to-digital converter (ADC) module (continued)

The ADC module in the 240xA has been enhanced to provide flexible interface to event managers A and B. The ADC interface is built around a fast, 10-bit ADC module with a total minimum conversion time of 375 ns (S/H + conversion). The ADC module has 16 channels, configurable as two independent 8-channel modules to service event managers A and B. The two independent 8-channel modules can be cascaded to form a 16-channel module. Although there are multiple input channels and two sequencers, there is only one converter in the ADC module. Figure 12 shows the block diagram of the 240xA ADC module.

The two 8-channel modules have the capability to autosequence a series of conversions, each module has the choice of selecting any one of the respective eight channels available through an analog MUX. In the cascaded mode, the autosequencer functions as a single 16-channel sequencer. On each sequencer, once the conversion is complete, the selected channel value is stored in its respective RESULT register. Autosequencing allows the system to convert the same channel multiple times, allowing the user to perform oversampling algorithms. This gives increased resolution over traditional single-sampled conversion results.

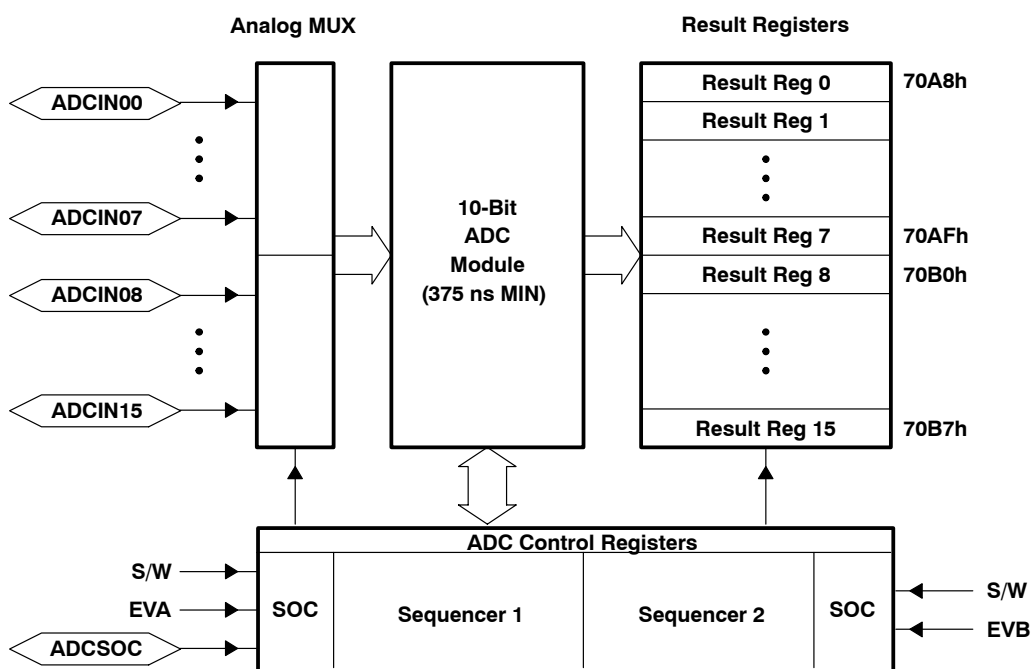

Figure 12. Block Diagram of the 240xA ADC Module

To obtain the specified accuracy of the ADC, proper board layout is critical. To the best extent possible, traces leading to the ADCINn pins should not run in close proximity to the digital signal paths. This is to minimize switching noise on the digital lines from getting coupled to the ADC inputs. Furthermore, proper isolation techniques must be used to isolate the ADC module power pins (such as V_{CCA} , V_{REFHI} , and V_{SSA}) from the digital supply. Unused ADC inputs should be connected to analog ground for improved accuracy and ESD protection.

controller area network (CAN) module

The CAN module is a full-CAN controller designed as a 16-bit peripheral module and supports the following features:

- CAN specification 2.0B (active)
 - Standard data and remote frames
 - Extended data and remote frames
- Six mailboxes for objects of 0- to 8-byte data length
 - Two receive mailboxes, two transmit mailboxes
 - Two configurable transmit/receive mailboxes
- Local acceptance mask registers for mailboxes 0 and 1 and mailboxes 2 and 3
- Configurable standard or extended message identifier
- Programmable bit rate
- Programmable interrupt scheme
- Readable error counters
- Self-test mode
 - In this mode, the CAN module operates in a loop-back fashion, receiving its own transmitted message.

The CAN module is a 16-bit peripheral. The accesses are split into the control/status-registers accesses and the mailbox-RAM accesses.

CAN peripheral registers: The CPU can access the CAN peripheral registers only using 16-bit write accesses. The CAN peripheral always presents full 16-bit data to the CPU bus during read cycles.

CAN controller architecture

Figure 13 shows the basic architecture of the CAN controller through this block diagram of the CAN Peripherals.

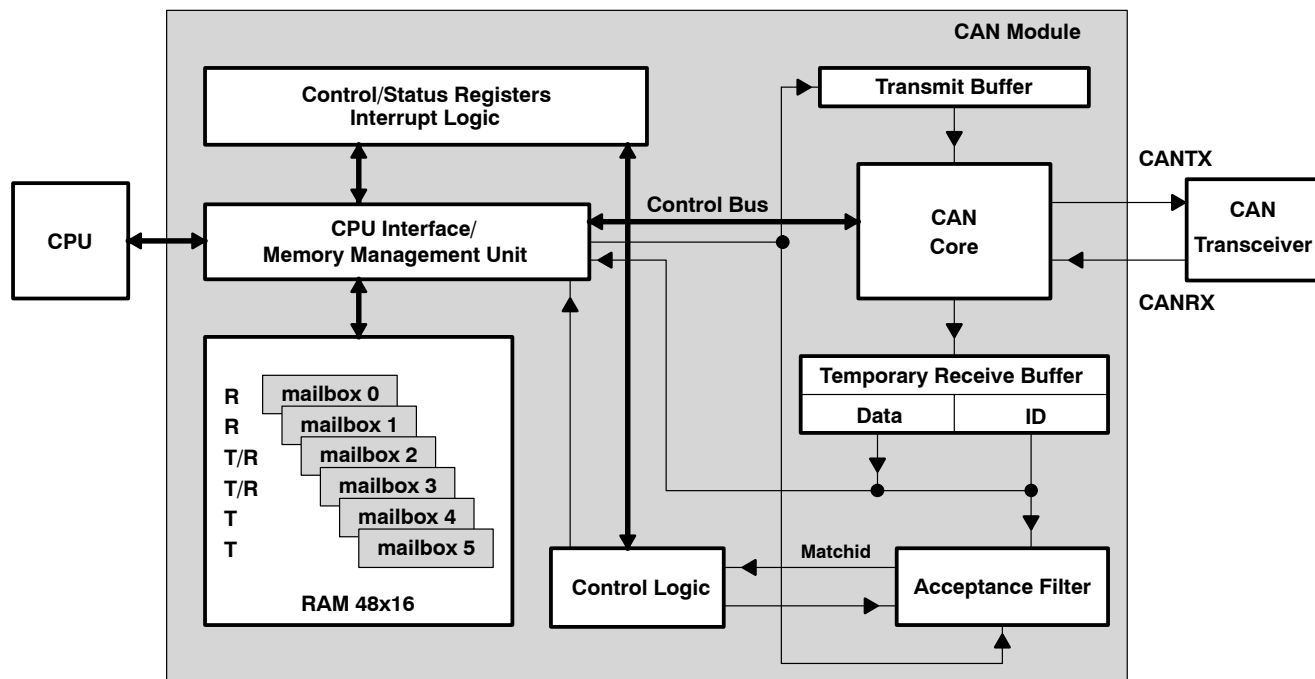

Figure 13. CAN Module Block Diagram

**TMS320LF2407A, TMS320LF2406A, TMS320LF2403A, TMS320LF2402A
TMS320LC2406A, TMS320LC2404A, TMS320LC2403A, TMS320LC2402A
DSP CONTROLLERS**

SPRS145L – JULY 2000 – REVISED SEPTEMBER 2007

controller area network (CAN) module (continued)

The mailboxes are situated in one 48-word x 16-bit RAM. It can be written to or read by the CPU or the CAN. The CAN write or read access, as well as the CPU read access, needs one clock cycle. The CPU write access needs two clock cycles. In these two clock cycles, the CAN performs a read-modify-write cycle and, therefore, inserts one wait state for the CPU.

Address bit 0 of the address bus used when accessing the RAM decides if the lower (0) or the higher (1) 16-bit word of the 32-bit word is taken. The RAM location is determined by the upper bits 5 to 1 of the address bus.

Table 8. 3.3-V CAN Transceivers for the TMS320Lx240xA DSPs

PART NUMBER	LOW-POWER MODE	INTEGRATED SLOPE CONTROL	V _{ref} PIN	T _A	MARKED AS†
SN65HVD230	370 μA standby mode	Yes	Yes	-40°C to 85°C	VP230
SN65HVD231	40 nA sleep mode	Yes	Yes		VP231
SN65HVD232	No standby or sleep mode	No	No		VP232

† This is the nomenclature printed on the device, since the footprint is too small to accommodate the entire part number.

CAN interrupt logic

There are two interrupt requests from the CAN module to the peripheral interrupt expansion (PIE) controller: the mailbox interrupt and the error interrupt. Both interrupts can assert either a high-priority request or a low-priority request to the CPU. Since CAN mailboxes can generate multiple interrupts, the software should read the CAN_IFR register for every interrupt and prioritize the interrupt service, or else, these multiple interrupts will not be recognized by the CPU and PIE hardware logic. Each interrupt routine should service all the interrupt bits that are set and clear them after service.



serial communications interface (SCI) module

The 240xA devices include a serial communications interface (SCI) module. The SCI module supports digital communications between the CPU and other asynchronous peripherals that use the standard non-return-to-zero (NRZ) format. The SCI receiver and transmitter are double-buffered, and each has its own separate enable and interrupt bits. Both can be operated independently or simultaneously in the full-duplex mode. To ensure data integrity, the SCI checks received data for break detection, parity, overrun, and framing errors. The bit rate is programmable to over 65000 different speeds through a 16-bit baud-select register. Features of the SCI module include:

- Two external pins:
 - SCITXD: SCI transmit-output pin
 - SCIRXD: SCI receive-input pin
- NOTE: Both pins can be used as GPIO if not used for SCI.
- Baud rate programmable to 64K different rates
 - Up to 2500 Kbps at 40-MHz CPUCLK
 - Data-word format
 - One start bit
 - Data-word length programmable from one to eight bits
 - Optional even/odd/no parity bit
 - One or two stop bits
 - Four error-detection flags: parity, overrun, framing, and break detection
 - Two wake-up multiprocessor modes: idle-line and address bit
 - Half- or full-duplex operation
 - Double-buffered receive and transmit functions
 - Transmitter and receiver operations can be accomplished through interrupt-driven or polled algorithms with status flags.
 - Transmitter: TXRDY flag (transmitter-buffer register is ready to receive another character) and TX EMPTY flag (transmitter-shift register is empty)
 - Receiver: RXRDY flag (receiver-buffer register is ready to receive another character), BRKDT flag (break condition occurred), and RX ERROR flag (monitoring four interrupt conditions)
 - Separate enable bits for transmitter and receiver interrupts (except BRKDT)
 - NRZ (non-return-to-zero) format
 - Ten SCI module control registers located in the control register frame beginning at address 7050h

NOTE: All registers in this module are 8-bit registers that are connected to the 16-bit peripheral bus. When a register is accessed, the register data is in the lower byte (7–0), and the upper byte (15–8) is read as zeros. Writing to the upper byte has no effect.

Figure 14 shows the SCI module block diagram.

**TMS320LF2407A, TMS320LF2406A, TMS320LF2403A, TMS320LF2402A
TMS320LC2406A, TMS320LC2404A, TMS320LC2403A, TMS320LC2402A
DSP CONTROLLERS**

SPRS145L – JULY 2000 – REVISED SEPTEMBER 2007

serial communications interface (SCI) module (continued)

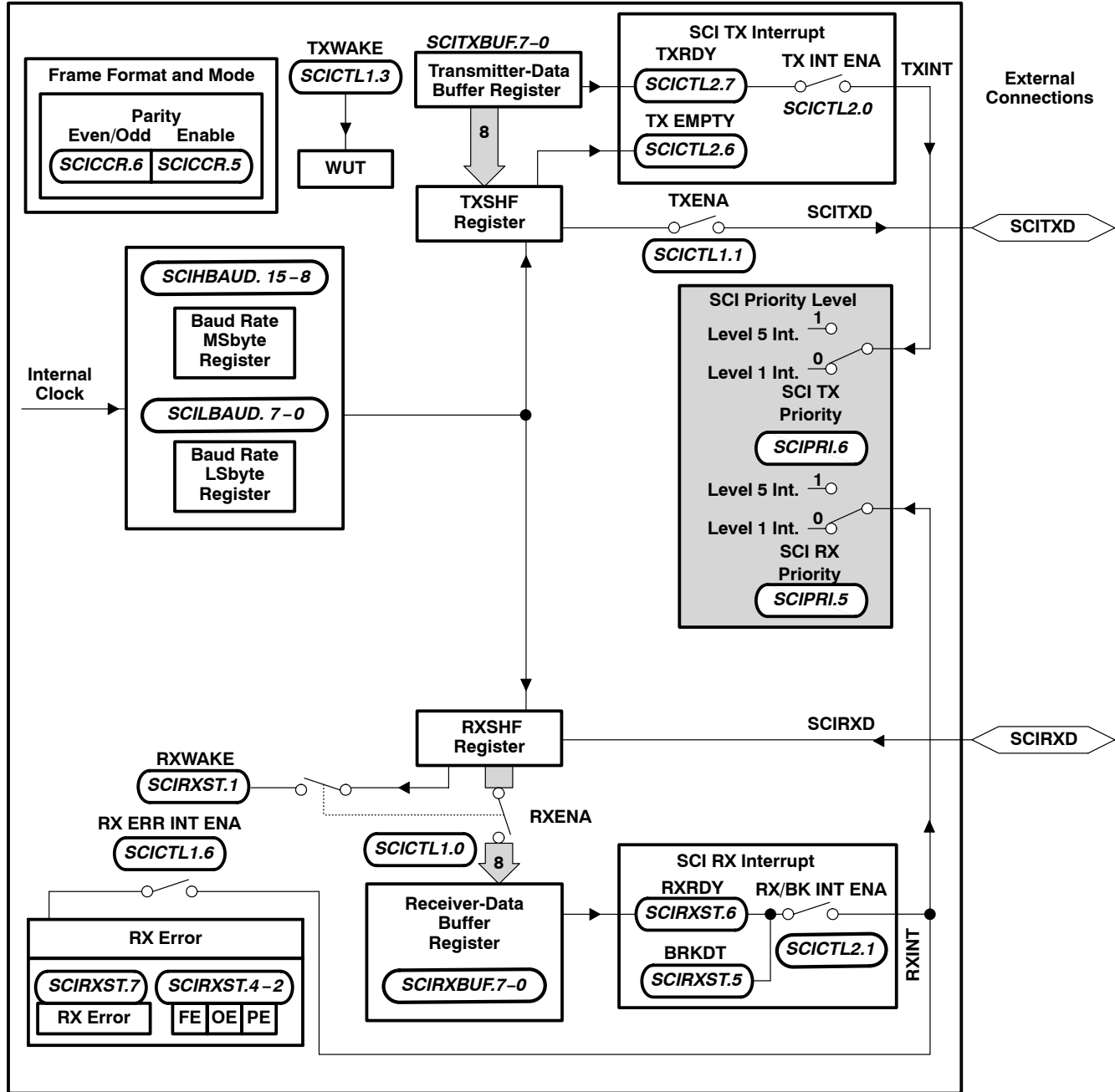

Figure 14. Serial Communications Interface (SCI) Module Block Diagram

serial peripheral interface (SPI) module

Some 240xA devices include the four-pin serial peripheral interface (SPI) module. The SPI is a high-speed, synchronous serial I/O port that allows a serial bit stream of programmed length (one to sixteen bits) to be shifted into and out of the device at a programmable bit-transfer rate. Normally, the SPI is used for communications between the DSP controller and external peripherals or another processor. Typical applications include external I/O or peripheral expansion through devices such as shift registers, display drivers, and ADCs. Multidevice communications are supported by the master/slave operation of the SPI.

The SPI module features include:

- Four external pins:
 - SPISOMI: SPI slave-output/master-input pin
 - SPISIMO: SPI slave-input/master-output pin
 - $\overline{\text{SPISTE}}$: SPI slave transmit-enable pin
 - SPICLK: SPI serial-clock pin
- NOTE: All four pins can be used as GPIO, if the SPI module is not used.
- Two operational modes: master and slave
 - Baud rate: 125 different programmable rates/10 Mbps at 40-MHz CPUCLK
 - Data word length: one to sixteen data bits
 - Four clocking schemes (controlled by clock polarity and clock phase bits) include:
 - Falling edge without phase delay: SPICLK active high. SPI transmits data on the falling edge of the SPICLK signal and receives data on the rising edge of the SPICLK signal.
 - Falling edge with phase delay: SPICLK active high. SPI transmits data one half-cycle ahead of the falling edge of the SPICLK signal and receives data on the falling edge of the SPICLK signal.
 - Rising edge without phase delay: SPICLK inactive low. SPI transmits data on the rising edge of the SPICLK signal and receives data on the falling edge of the SPICLK signal.
 - Rising edge with phase delay: SPICLK inactive low. SPI transmits data one half-cycle ahead of the falling edge of the SPICLK signal and receives data on the rising edge of the SPICLK signal.
 - Simultaneous receive and transmit operation (transmit function can be disabled in software)
 - Transmitter and receiver operations are accomplished through either interrupt-driven or polled algorithms.
 - Nine SPI module control registers: Located in control register frame beginning at address 7040h.

NOTE: All registers in this module are 16-bit registers that are connected to the 16-bit peripheral bus. When a register is accessed, the register data is in the lower byte (7–0), and the upper byte (15–8) is read as zeros. Writing to the upper byte has no effect.

**TMS320LF2407A, TMS320LF2406A, TMS320LF2403A, TMS320LF2402A
TMS320LC2406A, TMS320LC2404A, TMS320LC2403A, TMS320LC2402A
DSP CONTROLLERS**

SPRS145L – JULY 2000 – REVISED SEPTEMBER 2007

serial peripheral interface (SPI) module (continued)

Figure 15 is a block diagram of the SPI in slave mode.

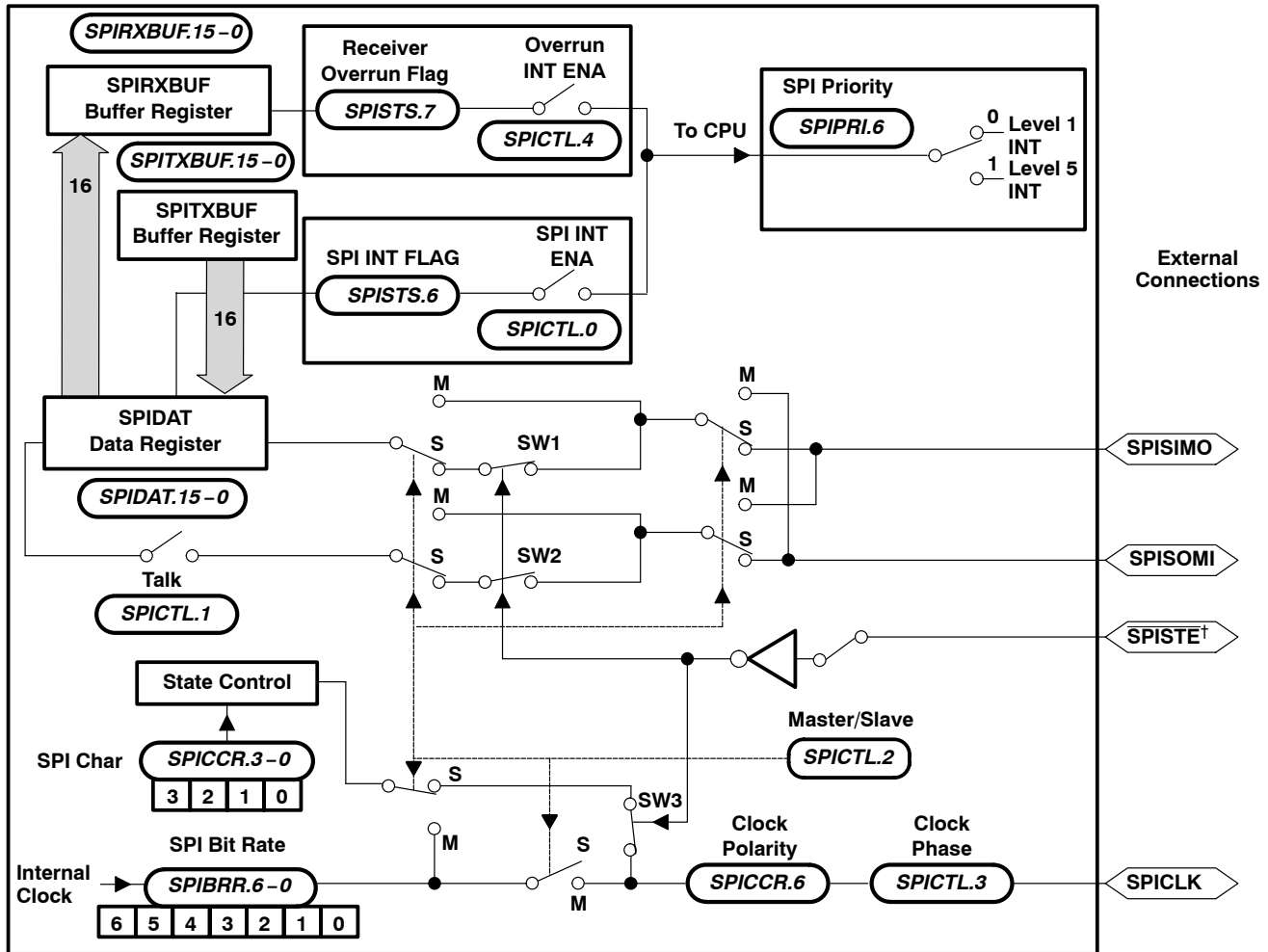

NOTE A: The diagram is shown in the slave mode.

† The SPISTE pin is driven low externally. Note that SW1, SW2, and SW3 are closed in this configuration. See the following errata for restrictions on using the SPISTE pin:

TMS320LF2407A, TMS320LF2406A, TMS320LF2403A, TMS320LF2402A DSP Controllers Silicon Errata
(literature number SPRZ002)

TMS320LC2406A, TMS320LC2404A, TMS320LC2402A DSP Controllers Silicon Errata (literature number SPRZ185)

Figure 15. Four-Pin Serial Peripheral Interface Module Block Diagram

SPI slave mode operation in LF2403A

The LF2403A device does not have the $\overline{\text{SPISTE}}/\text{IOPC5}$ pin. (This function is available as an internal signal only.) The following must be done to put the LF2403A SPI in slave mode:

1. Configure $\overline{\text{SPISTE}}/\text{IOPC5}$ signal for GPIO mode by clearing the MCRB.5 bit.
2. Configure $\overline{\text{SPISTE}}/\text{IOPC5}$ signal as an output (by writing a 1 to bit 13 of PCDATDIR) and drive it low (by writing a 0 to bit 5 of PCDATDIR). Note that $\overline{\text{SPISTE}}/\text{IOPC5}$ should not be driven low until after the SPI is configured and taken out of reset.

NOTE: The slave $\overline{\text{SPISTE}}/\text{IOPC5}$ signal must not be driven low until after the master **and** slave SPI modules are configured and taken out of reset. The initialization sequence is as follows:

- a. The master SPI is configured first and taken out of reset. This ensures that the master SPICLK is initialized to its appropriate level (high or low, depending on the polarity bit) first, before the slave SPI starts accepting clock pulses.
- b. The slave SPI is configured and taken out of reset.
- c. The GPIO/SPI pins of the slave is then configured for SPI operation and the $\overline{\text{SPISTE}}/\text{IOPC5}$ signal is driven low. This is done **after** ensuring the correct level of the master SPICLK signal. One method of doing this would be to read the level of the SPICLK pin through the PCDATDIR register and then deciding on the appropriate course of action.
- d. SPI transmission may commence now. Transmission of data should not be attempted until both master and slave are configured and the slave $\overline{\text{SPISTE}}/\text{IOPC5}$ signal is driven low.

PLL-based clock module

The 240xA has an on-chip, PLL-based clock module. This module provides all the necessary clocking signals for the device, as well as control for low-power mode entry. The PLL has a 3-bit ratio control to select different CPU clock rates. See Figure 16 for the PLL Clock Module Block Diagram, Table 9 for clock rates, and Table 10 for the loop filter component values.

The PLL-based clock module provides two modes of operation:

- Crystal-operation
This mode allows the use of an external crystal/resonator to provide the time base to the device.
- External clock source operation
This mode allows the internal oscillator to be bypassed. The device clocks are generated from an external clock source input on the XTAL1/CLKIN pin. In this case, an external oscillator clock is connected to the XTAL1/CLKIN pin.

PLL-based clock module (continued)

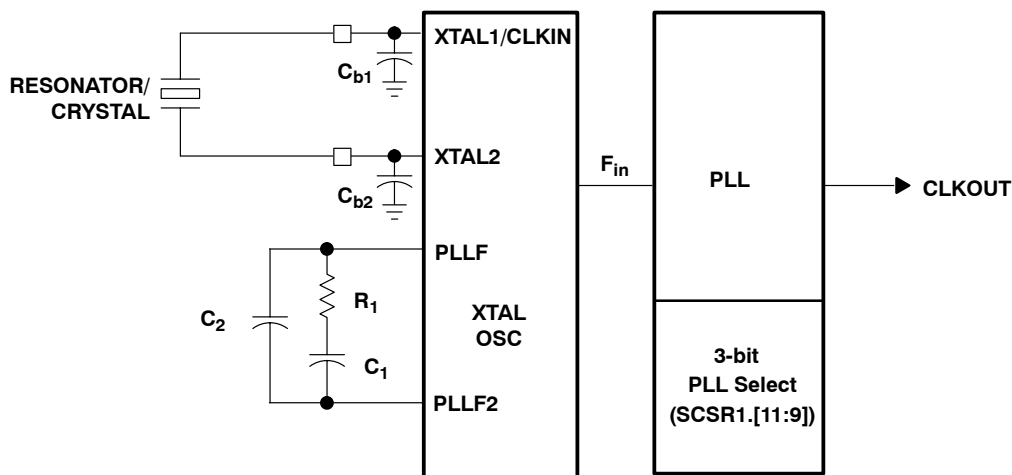

Figure 16. PLL Clock Module Block Diagram

Table 9. PLL Clock Selection Through Bits (11–9) in SCSR1 Register

CLK PS2	CLK PS1	CLK PS0	CLKOUT
0	0	0	$4 \times F_{in}$
0	0	1	$2 \times F_{in}$
0	1	0	$1.33 \times F_{in}$
0	1	1	$1 \times F_{in}$
1	0	0	$0.8 \times F_{in}$
1	0	1	$0.66 \times F_{in}$
1	1	0	$0.57 \times F_{in}$
1	1	1	$0.5 \times F_{in}$

Default multiplication factor after reset is (1,1,1), i.e., $0.5 \times F_{in}$.

NOTE:

The bootloader sets the PLL to x2 or x4 option. If the bootloader is used, the value of CLKIN used should not force CLKOUT to exceed the maximum rated device speed. See the “Boot ROM” section for more details.

external reference crystal clock option

The internal oscillator is enabled by connecting a crystal across the XTAL1/CLKIN and XTAL2 pins as shown in Figure 17a. The crystal should be in fundamental operation and parallel resonant, with an effective series resistance of 30 Ω – 150 Ω and draws no more than 1 mW; it should be specified at a load capacitance of 20 pF.

NOTE: Lx240xA crystal biasing needs an external 1 MΩ resistor across X1 and X2 pins for reliable operation. See the *TMS320LF2407A, LF2406A, LF2403A, LF2402A DSP Controllers Silicon Errata* (literature number SPRZ002) or the *TMS320LC2406A, TMS320LC2404A, TMS320LC2402A DSP Controllers Silicon Errata* (literature number SPRZ185) for details on this requirement.

external reference oscillator clock option

The internal oscillator is disabled by connecting a clock signal to XTAL1/CLKIN and leaving the XTAL2 input pin unconnected as shown in part b of Figure 17.

external reference oscillator clock option (continued)

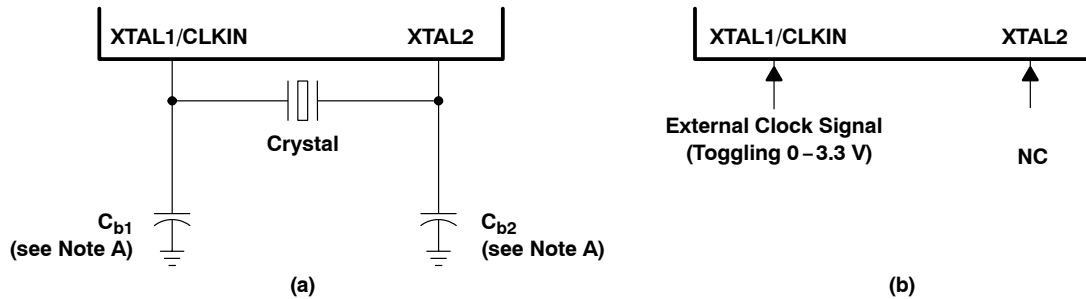

NOTE A: TI recommends that customers have the resonator/crystal vendor characterize the operation of their device with the DSP chip. The resonator/crystal vendor has the equipment and expertise to tune the tank circuit. The vendor can also advise the customer regarding the proper tank component values that will ensure start-up and stability over the entire operating range.

Figure 17. Recommended Crystal/Clock Connection

loop filter

The PLL module uses an external loop filter circuit for jitter minimization. The components for the loop filter circuit are R1, C1, and C2. The capacitors (C1 and C2) must be non-polarized. This loop filter circuit is connected between the PLLF and PLLF2 pins (see Figure 16). For examples of component values of R1, C1, and C2 at a specified oscillator frequency (XTAL1), see Table 10.

Table 10. Loop Filter Component Values With Damping Factor = 2.0

XTAL1/CLKIN FREQUENCY (MHz)	R1 (Ω) (±5% TOLERANCE) 1/4 W	C1 (μF) (±20% TOLERANCE)	C2 (μF) (±20% TOLERANCE)
4	4.7	3.9	0.082
5	5.6	2.7	0.056
6	6.8	1.8	0.039
7	8.2	1.5	0.033
8	9.1	1	0.022
9	10	0.82	0.015
10	11	0.68	0.015
11	12	0.56	0.012
12	13	0.47	0.01
13	15	0.39	0.0082
14	15	0.33	0.0068
15	16	0.33	0.0068
16	18	0.27	0.0056
17	18	0.22	0.0047
18	20	0.22	0.0047
19	22	0.18	0.0039
20	24	0.15	0.0033

low-power modes

The 240xA has an IDLE instruction. When executed, the IDLE instruction stops the clocks to all circuits in the CPU, but the clock output from the CPU continues to run. With this instruction, the CPU clocks can be shut down to save power while the peripherals (clocked with CLKOUT) continue to run. The CPU exits the IDLE state if it is reset, or, if it receives an interrupt request.

TMS320LF2407A, TMS320LF2406A, TMS320LF2403A, TMS320LF2402A TMS320LC2406A, TMS320LC2404A, TMS320LC2403A, TMS320LC2402A DSP CONTROLLERS

SPRS145L – JULY 2000 – REVISED SEPTEMBER 2007

clock domains

All 240xA-based devices have two clock domains:

1. CPU clock domain – consists of the clock for most of the CPU logic
2. System clock domain – consists of the peripheral clock (which is derived from CLKOUT of the CPU) and the clock for the interrupt logic in the CPU.

When the CPU goes into IDLE mode, the CPU clock domain is stopped while the system clock domain continues to run. This mode is also known as IDLE1 mode. The 240xA CPU also contains support for a second IDLE mode, IDLE2. By asserting IDLE2 to the 240xA CPU, both the CPU clock domain and the system clock domain are stopped, allowing further power savings. A third low-power mode, HALT mode, the deepest, is possible if the oscillator and WDCLK are also shut down when in IDLE2 mode.

Two control bits, LPM1 and LPM0, specify which of the three possible low-power modes is entered when the IDLE instruction is executed (see Table 11). These bits are located in the System Control and Status Register 1 (SCSR1), and they are described in the *TMS320LF/LC240xA DSP Controllers Reference Guide: System and Peripherals* (literature number SPRU357).

Table 11. Low-Power Modes Summary

LOW-POWER MODE	LPMx BITS SCSR1 [13:12]	CPU CLOCK DOMAIN	SYSTEM CLOCK DOMAIN	WDCLK STATUS	PLL STATUS	OSC STATUS	FLASH POWER	EXIT CONDITION
CPU running normally	XX	On	On	On	On	On	On	—
IDLE1 – (LPM0)	00	Off	On	On	On	On	On	Peripheral Interrupt, External Interrupt, Reset, PDPINTA/B
IDLE2 – (LPM1)	01	Off	Off	On	On	On	On	Wakeup Interrupts, External Interrupt, Reset, PDPINTA/B
HALT – (LPM2) [PLL/OSC power down]	1X	Off	Off	Off	Off	Off	Off†	Reset, PDPINTA/B

† The Flash must be powered down by the user code prior to entering LPM2. For more details, see the *TMS320LF/LC240xA DSP Controllers Reference Guide: System and Peripherals* (literature number SPRU357).

other power-down options

240xA devices have clock-enable bits to the following on-chip peripherals: ADC, SCI, SPI, CAN, EVB, and EVA. Clock to these peripherals are disabled after reset; thus, start-up power can be low for the device.

Depending on the application, these peripherals can be turned on/off to achieve low power.

See the SCSR1 register for details on the peripheral clock enable bits.

digital I/O and shared pin functions

The 240xA has up to 41 general-purpose, bidirectional, digital I/O (GPIO) pins—most of which are shared between primary functions and I/O. Most I/O pins of the 240xA are shared with other functions. The digital I/O ports module provides a flexible method for controlling both dedicated I/O and shared pin functions. All I/O and shared pin functions are controlled using eight 16-bit registers. These registers are divided into two types:



digital I/O and shared pin functions (continued)

- Output Control Registers — used to control the multiplexer selection that chooses between the primary function of a pin or the general-purpose I/O function.
- Data and Control Registers — used to control the data and data direction of bidirectional I/O pins.

description of shared I/O pins

The control structure for shared I/O pins is shown in Figure 18, where each pin has three bits that define its operation:

- MUX control bit — this bit selects between the primary function (1) and I/O function (0) of the pin.
- I/O direction bit — if the I/O function is selected for the pin (MUX control bit is set to 0), this bit determines whether the pin is an input (0) or an output (1).
- I/O data bit — if the I/O function is selected for the pin (MUX control bit is set to 0) and the direction selected is an input, data is read from this bit; if the direction selected is an output, data is written to this bit.

The MUX control bit, I/O direction bit, and I/O data bit are in the I/O control registers.

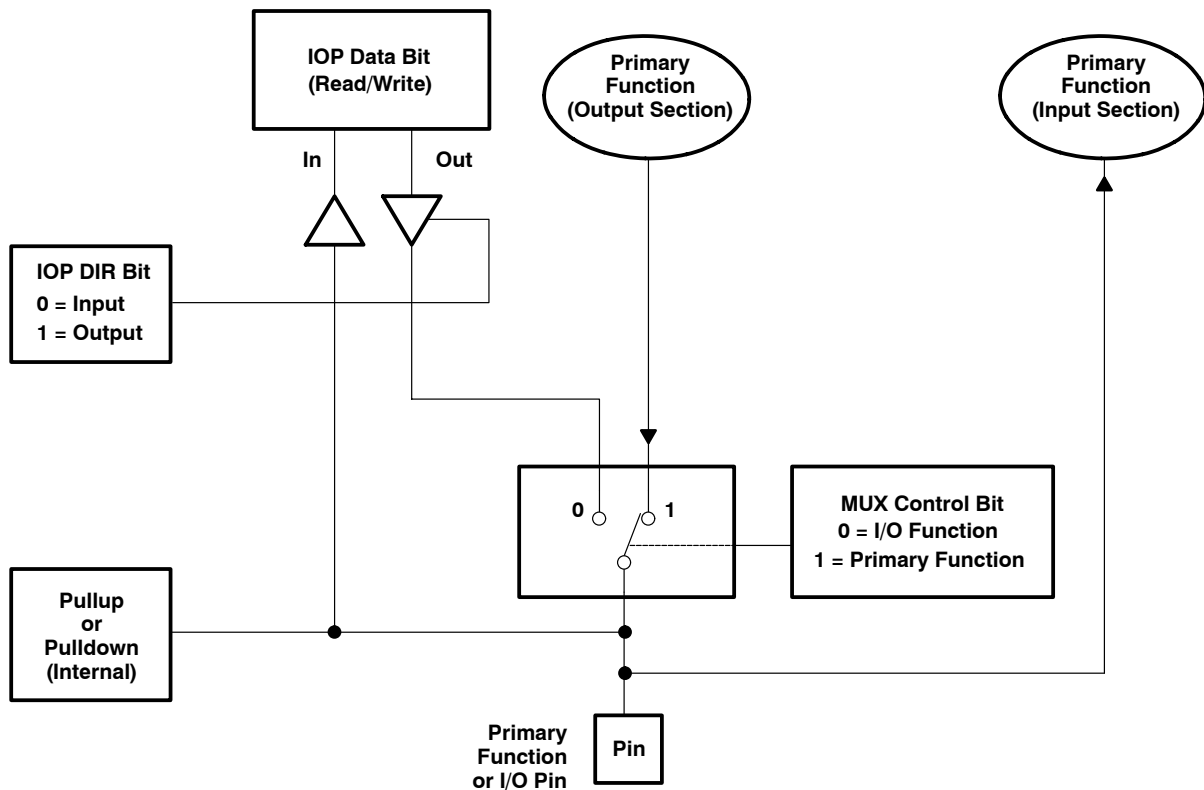

Figure 18. Shared Pin Configuration

A summary of shared pin configurations and associated bits is shown in Table 12.

**TMS320LF2407A, TMS320LF2406A, TMS320LF2403A, TMS320LF2402A
TMS320LC2406A, TMS320LC2404A, TMS320LC2403A, TMS320LC2402A
DSP CONTROLLERS**

SPRS145L – JULY 2000 – REVISED SEPTEMBER 2007

description of shared I/O pins (continued)

Table 12. Shared Pin Configurations[†]

PIN FUNCTION SELECTED		MUX CONTROL REGISTER (name.bit #)	MUX CONTROL VALUE AT RESET (MCRx.n)	I/O PORT DATA AND DIRECTION [‡]		
(MCRx.n = 1) Primary Function	(MCRx.N = 0) I/O			REGISTER	DATA BIT NO. [§]	DIR BIT NO. [¶]
				PORT A		
SCITXD	<i>IOPA0</i>	MCRA.0	0	PADATDIR	0	8
SCIRXD	<i>IOPA1</i>	MCRA.1	0	PADATDIR	1	9
XINT1	<i>IOPA2</i>	MCRA.2	0	PADATDIR	2	10
CAP1/QEP1	<i>IOPA3</i>	MCRA.3	0	PADATDIR	3	11
CAP2/QEP2	<i>IOPA4</i>	MCRA.4	0	PADATDIR	4	12
CAP3	<i>IOPA5</i>	MCRA.5	0	PADATDIR	5	13
PWM1	<i>IOPA6</i>	MCRA.6	0	PADATDIR	6	14
PWM2	<i>IOPA7</i>	MCRA.7	0	PADATDIR	7	15
				PORT B		
PWM3	<i>IOPB0</i>	MCRA.8	0	PBDATDIR	0	8
PWM4	<i>IOPB1</i>	MCRA.9	0	PBDATDIR	1	9
PWM5	<i>IOPB2</i>	MCRA.10	0	PBDATDIR	2	10
PWM6	<i>IOPB3</i>	MCRA.11	0	PBDATDIR	3	11
T1PWM/T1CMP	<i>IOPB4</i>	MCRA.12	0	PBDATDIR	4	12
T2PWM/T2CMP	<i>IOPB5</i>	MCRA.13	0	PBDATDIR	5	13
TDIRA	<i>IOPB6</i>	MCRA.14	0	PBDATDIR	6	14
TCLKINA	<i>IOPB7</i>	MCRA.15	0	PBDATDIR	7	15
				PORT C		
<i>W/R[#]</i>	IOPC0	MCRB.0	1	PCDATDIR	0	8
<i>BIO</i>	IOPC1	MCRB.1	1	PCDATDIR	1	9
SPISIMO	<i>IOPC2</i>	MCRB.2	0	PCDATDIR	2	10
SPISOMI	<i>IOPC3</i>	MCRB.3	0	PCDATDIR	3	11
SPICLK	<i>IOPC4</i>	MCRB.4	0	PCDATDIR	4	12
SPISTE	<i>IOPC5</i>	MCRB.5	0	PCDATDIR	5	13
CANTX	<i>IOPC6</i>	MCRB.6	0	PCDATDIR	6	14
CANRX	<i>IOPC7</i>	MCRB.7	0	PCDATDIR	7	15
				PORT D		
XINT2/ADCSOC	<i>IOPD0</i>	MCRB.8	0	PDDATDIR	0	8
<i>EMU0</i>	Reserved	MCRB.9	1	PDDATDIR	1	9
<i>EMU1</i>	Reserved	MCRB.10	1	PDDATDIR	2	10
<i>TCK</i>	Reserved	MCRB.11	1	PDDATDIR	3	11
<i>TDI</i>	Reserved	MCRB.12	1	PDDATDIR	4	12
<i>TDO</i>	Reserved	MCRB.13	1	PDDATDIR	5	13
<i>TMS</i>	Reserved	MCRB.14	1	PDDATDIR	6	14
<i>TMS2</i>	Reserved	MCRB.15	1	PDDATDIR	7	15

[†] Bold, italicized pin names indicate pin functions at reset.

[‡] Valid only if the I/O function is selected on the pin

[§] If the GPIO pin is configured as an output, these bits can be written to. If the pin is configured as an input, these bits are read from.

[¶] If the DIR bit is 0, the GPIO pin functions as an input. For a value of 1, the pin is configured as an output.

[#] At reset, all LF240xA devices come up with the W/R/IOPC0 pin in W/R mode. On devices that lack an external memory interface (e.g., LF2406A), W/R mode is not functional and MCRB.0 must be set to a 0 if the IOPC0 pin is to be used. The XMIF Hi-Z control bit (bit 4 of the SCSR2 register) is reserved in these devices and must be written with a zero.

^{||} Bits 15 through 9 of the MCRB register *must* be written as 1 only. Writing a 0 to any of these bits will cause unpredictable operation of the device.



**TMS320LF2407A, TMS320LF2406A, TMS320LF2403A, TMS320LF2402A
TMS320LC2406A, TMS320LC2404A, TMS320LC2403A, TMS320LC2402A
DSP CONTROLLERS**

SPRS145L – JULY 2000 – REVISED SEPTEMBER 2007

description of shared I/O pins (continued)

Table 12. Shared Pin Configurations[†] (Continued)

PIN FUNCTION SELECTED		MUX CONTROL REGISTER (name.bit #)	MUX CONTROL VALUE AT RESET (MCRx.n)	I/O PORT DATA AND DIRECTION [‡]		
(MCRx.n = 1) Primary Function	(MCRX.N = 0) I/O			REGISTER	DATA BIT NO. [§]	DIR BIT NO. [¶]
PORT E						
<i>CLKOUT</i>	IOPE0	MCRC.0	1	PEDATDIR	0	8
PWM7	<i>IOPE1</i>	MCRC.1	0	PEDATDIR	1	9
PWM8	<i>IOPE2</i>	MCRC.2	0	PEDATDIR	2	10
PWM9	<i>IOPE3</i>	MCRC.3	0	PEDATDIR	3	11
PWM10	<i>IOPE4</i>	MCRC.4	0	PEDATDIR	4	12
PWM11	<i>IOPE5</i>	MCRC.5	0	PEDATDIR	5	13
PWM12	<i>IOPE6</i>	MCRC.6	0	PEDATDIR	6	14
CAP4/QEP3	<i>IOPE7</i>	MCRC.7	0	PEDATDIR	7	15
PORT F						
CAP5/QEP4	<i>IOPF0</i>	MCRC.8	0	PFDATDIR	0	8
CAP6	<i>IOPF1</i>	MCRC.9	0	PFDATDIR	1	9
T3PWM/T3CMP	<i>IOPF2</i>	MCRC.10	0	PFDATDIR	2	10
T4PWM/T4CMP	<i>IOPF3</i>	MCRC.11	0	PFDATDIR	3	11
TDIRB	<i>IOPF4</i>	MCRC.12	0	PFDATDIR	4	12
TCLKINB	<i>IOPF5</i>	MCRC.13	0	PFDATDIR	5	13

[†] Bold, italicized pin names indicate pin functions at reset.

[‡] Valid only if the I/O function is selected on the pin

[§] If the GPIO pin is configured as an output, these bits can be written to. If the pin is configured as an input, these bits are read from.

[¶] If the DIR bit is 0, the GPIO pin functions as an input. For a value of 1, the pin is configured as an output.

[#] At reset, all LF240xA devices come up with the W/R/IOPC0 pin in W/R mode. On devices that lack an external memory interface (e.g., LF2406A), W/R mode is not functional and MCRB.0 must be set to a 0 if the IOPC0 pin is to be used. The XMIF Hi-Z control bit (bit 4 of the SCSR2 register) is reserved in these devices and must be written with a zero.

^{||} Bits 15 through 9 of the MCRB register *must* be written as 1 only. Writing a 0 to any of these bits will cause unpredictable operation of the device.

digital I/O control registers

Table 13 lists the registers available in the digital I/O module. As with other 240xA peripherals, these registers are memory-mapped to the data space.

Table 13. Addresses of Digital I/O Control Registers

ADDRESS	REGISTER	NAME
7090h	MCRA	I/O MUX control register A
7092h	MCRB	I/O mux control register B
7094h	MCRC	I/O mux control register C
7095h	PEDATDIR	I/O port E data and direction register
7096h	PFDATDIR	I/O port F data and direction register
7098h	PADATDIR	I/O port A data and direction register
709Ah	PBDATDIR	I/O port B data and direction register
709Ch	PCDATDIR	I/O port C data and direction register
709Eh	PDDATDIR	I/O port D data and direction register



TMS320LF2407A, TMS320LF2406A, TMS320LF2403A, TMS320LF2402A TMS320LC2406A, TMS320LC2404A, TMS320LC2403A, TMS320LC2402A DSP CONTROLLERS

SPRS145L – JULY 2000 – REVISED SEPTEMBER 2007

external memory interface (LF2407A)

The TMS320LF2407A can address up to $64K \times 16$ words of memory (or registers) in each of the program, data, and I/O spaces. On-chip memory, when enabled, occupies some of this off-chip range.

The CPU of the TMS320LF2407A schedules a program fetch, data read, and data write on the same machine cycle. This is because from on-chip memory, the CPU can execute all three of these operations in the same cycle. However, the external interface multiplexes the internal buses to one address bus and one data bus. The external interface sequences these operations to complete first the data write, then the data read, and finally the program read.

The LF2407A supports a wide range of system interfacing requirements. Program, data, and I/O address spaces provide interface to memory and I/O, thereby maximizing system throughput. The full 16-bit address and data buses, along with the \overline{PS} , \overline{DS} , and \overline{IS} space-select signals, allow addressing of 64K 16-bit words in program, data, and I/O space. Since on-chip peripheral registers occupy positions of data-memory space (7000–7FFF), the externally addressable data-memory space is 32K 16-bit words (8000–FFFF). Note that the global memory space of the C2xx core is not used for 240xA DSP devices. Therefore, the global memory allocation register (GREG) is reserved for all these devices.

Input/output (I/O) design is simplified by having I/O space treated the same way as memory. I/O devices are accessed in the I/O address space using the processor's external address and data buses in the same manner as memory-mapped devices.

The LF2407A external parallel interface provides various control signals to facilitate interfacing to the device. The R/\overline{W} output signal is provided to indicate whether the current cycle is a read or a write. The \overline{STRB} output signal provides a timing reference for all external cycles. For convenience, the device also provides the \overline{RD} and the \overline{WE} output signals, which indicate a read cycle and a write cycle, respectively, along with timing information for those cycles. The availability of these signals minimizes external gating necessary for interfacing external devices to the LF2407A.

The 2407A provides \overline{RD} and W/\overline{R} signals to help the zero-wait-state external memory interface. At higher CLKOUT speeds, \overline{RD} may not meet the slow memory device's timing. In such instances, the W/\overline{R} signal could be used as an alternative signal with some tradeoffs. See the timing parameters for details.

The TMS320LF2407A supports zero-wait-state reads on the external interface. However, to avoid bus conflicts, writes take two cycles. This allows the TMS320LF2407A to buffer the transition of the data bus from input to output (or from output to input) by a half cycle. In most systems, the TMS320LF2407A ratio of reads to writes is significantly large to minimize the overhead of the extra cycle on writes.

wait-state generation (LF2407A only)

Wait-state generation is incorporated in the LF2407A without any external hardware for interfacing the LF2407A with slower off-chip memory and I/O devices. Adding wait states lengthens the time the CPU waits for external memory or an external I/O port to respond when the CPU reads from or writes to that external memory or I/O port. Specifically, the CPU waits one extra cycle (one CLKOUT cycle) for every wait state. The wait states operate on CLKOUT cycle boundaries.

To avoid bus conflicts, writes from the LF2407A always take at least two CLKOUT cycles. The LF2407A offers two options for generating wait states:

- **READY Signal.** With the READY signal, you can externally generate any number of wait states. The READY pin has no effect on accesses to *internal* memory.
- **On-Chip Wait-State Generator.** With this generator, you can generate zero to seven wait states.



generating wait states with the READY signal

When the READY signal is low, the LF2407A waits one CLKOUT cycle and then checks READY again. The LF2407A does not continue executing until the READY signal is driven high; therefore, if the READY signal is not used, it should be pulled high.

The READY pin can be used to generate any number of wait states. However, when the LF2407A operates at full speed, it may not respond fast enough to provide a READY-based wait state for the first cycle. For extended wait states using external READY logic, the on-chip wait-state generator should be programmed to generate at least one wait state.

generating wait states with the LF2407A on-chip software wait-state generator

The software wait-state generator can be programmed to generate zero to seven wait states for a given off-chip memory space (program, data, or I/O), regardless of the state of the READY signal. These zero to seven wait states are controlled by the wait-state generator register (WSGR) (I/O FFFFh). For more detailed information on the WSGR and associated bit functions, see the *TMS320LF/LC240xA DSP Controllers Reference Guide: System and Peripherals* (literature number SPRU357).

watchdog (WD) timer module

The x240xA devices include a watchdog (WD) timer module. The WD function of this module monitors software and hardware operation by generating a system reset if it is not periodically serviced by software by having the correct key written. The WD timer operates independently of the CPU. It does not need any CPU initialization to function. When a system reset occurs, the WD timer defaults to the fastest WD timer rate available (WDCLK signal = CLKOUT/512). As soon as reset is released internally, the CPU starts executing code, and the WD timer begins incrementing. This means that, to avoid a premature reset, WD setup should occur early in the power-up sequence. See Figure 19 for a block diagram of the WD module. The WD module features include the following:

- WD Timer
 - Seven different WD overflow rates
 - A WD-reset key (WDKEY) register that clears the WD counter when a correct value is written, and generates a system reset if an incorrect value is written to the register
 - WD check bits that initiate a system reset if an incorrect value is written to the WD control register (WDCR)
- Automatic activation of the WD timer, once system reset is released
 - Three WD control registers located in control register frame beginning at address 7020h.

NOTE: All registers in this module are 8-bit registers. When a register is accessed, the register data is in the lower byte, the upper byte is read as zeros. Writing to the upper byte has no effect.

Figure 19 shows the WD block diagram. Table 14 shows the different WD overflow (time-out) selections.

The watchdog can be disabled in software by writing '1' to bit 6 of the WDCR register (WDCR.6) while bit 5 of the SCSR2 register (SCSR2.5) is 1. If SCSR2.5 is 0, the watchdog will not be disabled. SCSR2.5 is equivalent to the WDDIS pin of the TMS320F243/241 devices.

**TMS320LF2407A, TMS320LF2406A, TMS320LF2403A, TMS320LF2402A
TMS320LC2406A, TMS320LC2404A, TMS320LC2403A, TMS320LC2402A
DSP CONTROLLERS**

SPRS145L – JULY 2000 – REVISED SEPTEMBER 2007

watchdog (WD) timer module (continued)

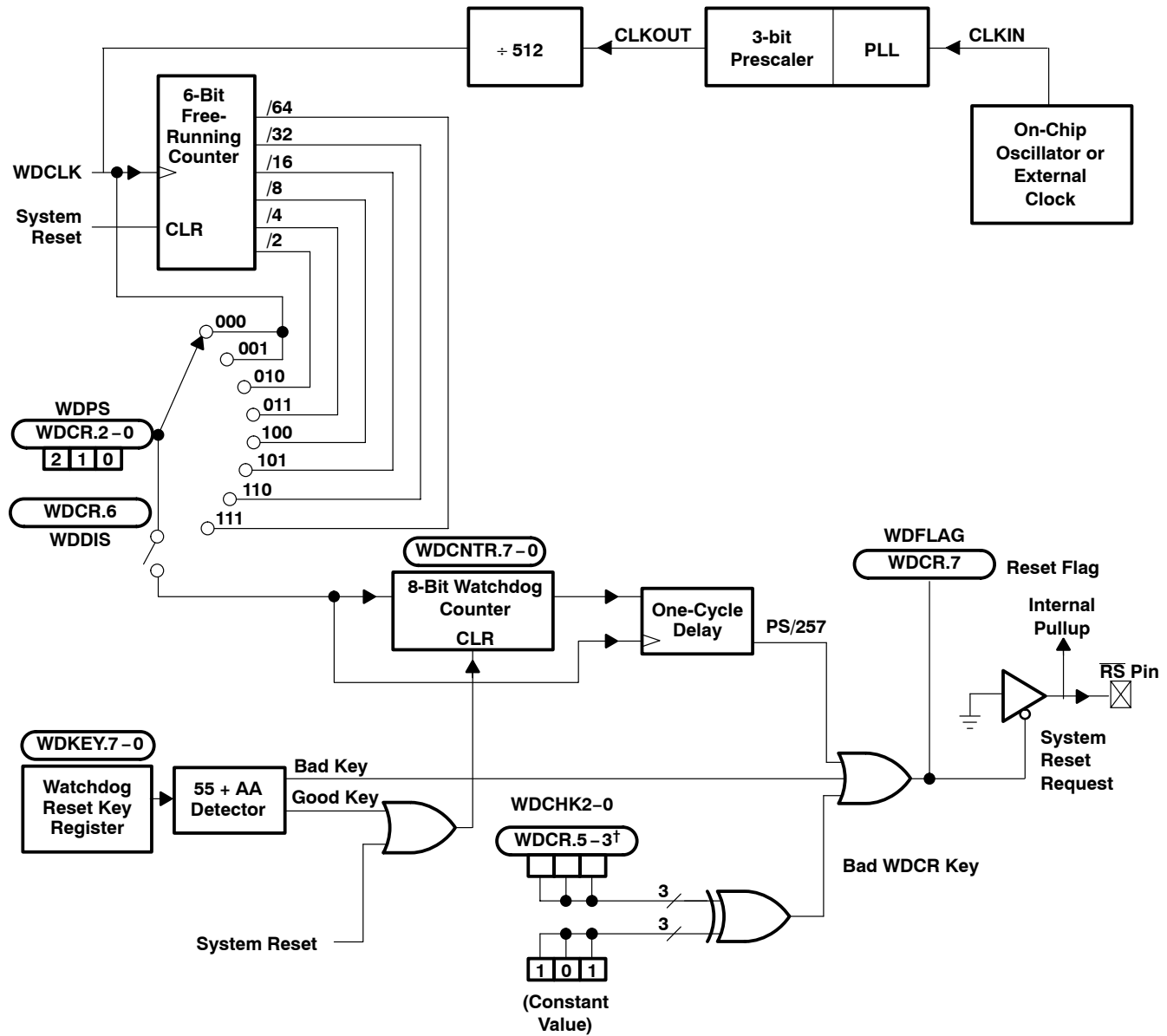

† Writing to bits WDCR.5-3 with anything but the correct pattern (101) generates a system reset.

Figure 19. Block Diagram of the WD Module

watchdog (WD) timer module (continued)

Table 14. WD Overflow (Time-out) Selections

WD PRESCALE SELECT BITS			WDCLK DIVIDER	WATCHDOG CLOCK RATE [†]
WDPS2	WDPS1	WDPS0		FREQUENCY (Hz)
0	0	X [‡]	1	WDCLK/1
0	1	0	2	WDCLK/2
0	1	1	4	WDCLK/4
1	0	0	8	WDCLK/8
1	0	1	16	WDCLK/16
1	1	0	32	WDCLK/32
1	1	1	64	WDCLK/64

[†] WDCLK = CLKOUT/512

[‡] X = Don't care

development support

Texas Instruments (TI) offers an extensive line of development tools for the x240xA generation of DSPs, including tools to evaluate the performance of the processors, generate code, develop algorithm implementations, and fully integrate and debug software and hardware modules.

The following products support development of x240xA-based applications:

Software Development Tools:

- Assembler/linker
- Simulator
- Optimizing ANSI C compiler
- Application algorithms
- C/Assembly debugger and code profiler

Hardware Development Tools:

- Emulator XDS510™ (supports x24x multiprocessor system debug)
- TMS320LF2407 EVM (Evaluation module for 2407 DSP)

See Table 15 and Table 16 for complete listings of development support tools for the x240xA. For information on pricing and availability, contact the nearest TI field sales office or authorized distributor.

Table 15. Development Support Tools

DEVELOPMENT TOOL	PLATFORM	PART NUMBER
Software		
Code Composer Studio™ v.2.2	PC™	TMDSCCS2000-1
Hardware – Emulation Debug Tools		
XDS510PP™ Pod (Parallel Port) with JTAG cable	PC	TMDS3P701014

PC is a trademark of International Business Machines Corp..

Code Composer Studio, XDS510, and XDS510PP are trademarks of Texas Instruments.



**TMS320LF2407A, TMS320LF2406A, TMS320LF2403A, TMS320LF2402A
TMS320LC2406A, TMS320LC2404A, TMS320LC2403A, TMS320LC2402A
DSP CONTROLLERS**

SPRS145L – JULY 2000 – REVISED SEPTEMBER 2007

development support (continued)

Table 16. TMS320x24x-Specific Development Tools

DEVELOPMENT TOOL	PLATFORM	PART NUMBER
Hardware – Evaluation/Starter Kits		
2401A eZdsp	PC	TMDS eZD2401
F2407A EVM	PC	TMDS3P701016A
LF2407A eZdsp	PC	TMDSEZD2407

The LF2407 Evaluation Module (EVM) provide designers of motor and motion control applications with a complete and cost-effective way to take their designs from concept to production. These tools offer both a hardware and software development environment and include:

- Flash-based LF240xA evaluation board
- Code Generation Tools
- Assembler/Linker
- C Compiler
- Source code debugger
- C24x™ Debugger
- Code Composer IDE
- XDS510PP™ JTAG-based emulator
- Sample applications code
- Universal 5-V DC power supply
- Documentation and cables

device and development support tool nomenclature

To designate the stages in the product development cycle, TI assigns prefixes to the part numbers of all TMS320™ DSP devices and support tools. Each TMS320™ DSP commercial family member has one of three prefixes: TMX, TMP, or TMS. Texas Instruments recommends two of three possible prefix designators for its support tools: TMDX and TMDS. These prefixes represent evolutionary stages of product development from engineering prototypes (TMX/TMDX) through fully qualified production devices/tools (TMS/TMDS).

Device development evolutionary flow:

- TMX** Experimental device that is not necessarily representative of the final device’s electrical specifications
- TMP** Final silicon die that conforms to the device’s electrical specifications but has not completed quality and reliability verification
- TMS** Fully qualified production device

Support tool development evolutionary flow:

- TMDX** Development-support product that has not yet completed Texas Instruments internal qualification testing.
- TMDS** Fully qualified development-support product

TMX and TMP devices and TMDX development-support tools are shipped against the following disclaimer:

“Developmental product is intended for internal evaluation purposes.”

TMS devices and TMDS development-support tools have been characterized fully, and the quality and reliability of the device have been demonstrated fully. TI’s standard warranty applies.

TMS320 is a trademark of Texas Instruments.
eZdsp is a trademark of Spectrum Digital, Inc.



TMS320LF2407A, TMS320LF2406A, TMS320LF2403A, TMS320LF2402A TMS320LC2406A, TMS320LC2404A, TMS320LC2403A, TMS320LC2402A DSP CONTROLLERS

SPRS145L – JULY 2000 – REVISED SEPTEMBER 2007

device and development support tool nomenclature (continued)

Predictions show that prototype devices (TMX or TMP) have a greater failure rate than the standard production devices. Texas Instruments recommends that these devices not be used in any production system because their expected end-use failure rate still is undefined. Only qualified production devices are to be used.

TI device nomenclature also includes a suffix with the device family name. This suffix indicates the package type (for example, PAG, PG, PGE, and PZ) and temperature range (for example, A). Figure 20 provides a legend for reading the complete device name for any TMS320x240xA family member. See the timing section for specific options that are available on 240xA devices.

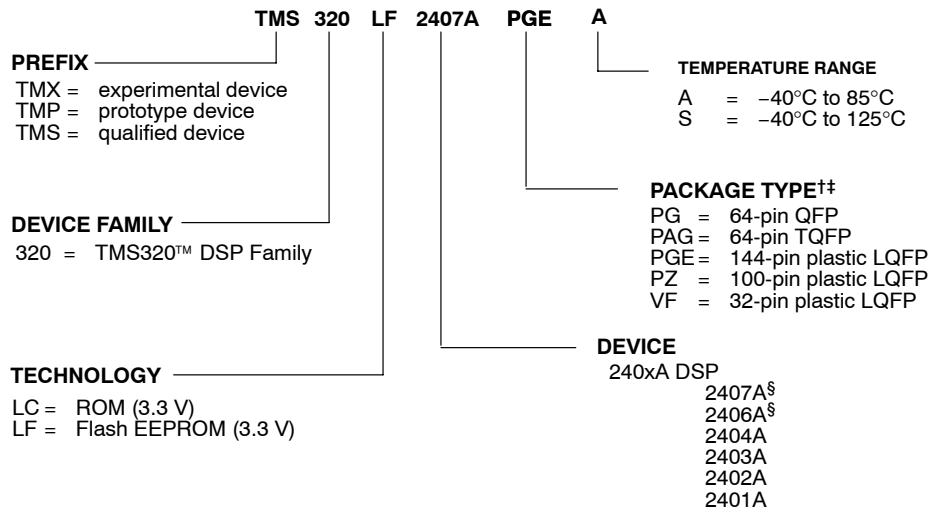

† QFP = Quad Flatpack
LQFP = Low-Profile Quad Flatpack
TQFP = Thin Quad Flatpack

‡ Not yet available Lead (Pb)-free. For estimated conversion dates, go to www.ti.com/leadfree

§ The package dimensions of the 2407A and 2406A devices correspond to the LQFP package. These devices were stated to be in TQFP packaging in the TMX data sheets. The package dimensions have *not* changed; only the package designation has changed.

Figure 20. TMS320x240xA Device Nomenclature



TMS320LF2407A, TMS320LF2406A, TMS320LF2403A, TMS320LF2402A TMS320LC2406A, TMS320LC2404A, TMS320LC2403A, TMS320LC2402A DSP CONTROLLERS

SPRS145L – JULY 2000 – REVISED SEPTEMBER 2007

documentation support

Extensive documentation supports all of the TMS320™ DSP family generations of devices from product announcement through applications development. The types of documentation available include: data sheets, such as this document, with design specifications; complete user's guides for all devices and development support tools; and hardware and software applications. Useful reference documentation includes:

- User Guides
 - *TMS320LF/LC240xA DSP Controllers Reference Guide: System and Peripherals* (literature number SPRU357)
 - Manual Update Sheet for *TMS320LF/LC240xA DSP Controllers Reference Guide: System and Peripherals* (SPRU357) [literature number SPRZ015]
 - *TMS320C240 DSP Controllers CPU, System, and Instruction Set Reference Guide* (literature number SPRU160)
- Data Sheets
 - *TMS320LF2407A, TMS320LF2406A, TMS320LF2403A, TMS320LF2402A, TMS320LC2406A, TMS320LC2404A, TMS320LC2402A DSP Controllers* (literature number SPRS145)
 - *TMS320LF2407, TMS320LF2406, TMS320LF2402 DSP Controllers* (literature number SPRS094)
 - *TMS320LF2401A DSP Controller* (literature number SPRS161)
- Application Reports
 - *3.3-V DSP for Digital Motor Control* (literature number SPRA550)

To receive copies of TMS320™ DSP literature, contact the Literature Response Center at 800-477-8924.

A series of DSP textbooks is published by Prentice-Hall and John Wiley & Sons to support digital signal processing research and education. The TMS320™ DSP newsletter, *Details on Signal Processing*, is published quarterly and distributed to update TMS320™ DSP customers on product information.

Updated information on the TMS320™ DSP controllers can be found on the worldwide web at: <http://www.ti.com>.

To send comments regarding this TMS320x240xA data sheet (literature number SPRS145), use the comments@books.sc.ti.com email address, which is a repository for feedback. For questions and support, contact the Product Information Center listed at the <http://www.ti.com/sc/docs/pic/home.htm> site.



TMS320LF2407A, TMS320LF2406A, TMS320LF2403A, TMS320LF2402A TMS320LC2406A, TMS320LC2404A, TMS320LC2403A, TMS320LC2402A DSP CONTROLLERS

SPRS145L – JULY 2000 – REVISED SEPTEMBER 2007

LF240xA AND LC240xA ELECTRICAL SPECIFICATIONS DATA

absolute maximum ratings over operating free-air temperature ranges (unless otherwise noted)[†]

Supply voltage range, V_{DD} , $PLL_{V_{CCA}}$, V_{DDO} , and V_{CCA} (see Note 1)	– 0.3 V to 4.6 V
V_{CCP} range	– 0.3 V to 5.5 V
Input voltage range, V_{IN}	– 0.3 V to 4.6 V
Output voltage range, V_O LF240xA	– 0.3 V to 4.6 V
Output voltage range, V_O LC240xA	– 0.3 V to 4.6 V
Input clamp current, I_{IK} ($V_{IN} < 0$ or $V_{IN} > V_{CC}$)	± 20 mA
Output clamp current, I_{OK} ($V_O < 0$ or $V_O > V_{CC}$)	± 20 mA
Operating free-air temperature ranges, T_A : A version	– 40°C to 85°C
S version	– 40°C to 125°C
Junction temperature range, T_J (see Note 2)	– 40°C to 150°C
Storage temperature range, T_{stg} (see Note 2)	– 65°C to 150°C

[†] Clamp current stresses beyond those listed under “absolute maximum ratings” may cause permanent damage to the device. These are stress ratings only, and functional operation of the device at these or any other conditions beyond those indicated under “recommended operating conditions” is not implied. Exposure to absolute-maximum-rated conditions for extended periods may affect device reliability.

NOTES: 1. All voltage values are with respect to V_{SS} .

2. Long-term high-temperature storage and/or extended use at maximum temperature conditions may result in a reduction of overall device life. For additional information, see the *IC Package Thermal Metrics Application Report* (literature number SPRA953) and the *Reliability Data for TMS320LF24x and TMS320F281x Devices Application Report* (literature number SPRA963).

recommended operating conditions^{‡§}

			MIN	NOM	MAX	UNIT
V_{DD}/V_{DDO}	Supply voltage	$V_{DDO} = V_{DD} \pm 0.3$ V	3	3.3	3.6	V
V_{SS}	Supply ground		0	0	0	V
$PLL_{V_{CCA}}$	PLL supply voltage		3	3.3	3.6	V
V_{CCA}^{\ddagger}	ADC supply voltage		3	3.3	3.6	V
V_{CCP}	Flash programming supply voltage [#]		4.75	5	5.25	V
f_{CLKOUT}	Device clock frequency (system clock)		2		40	MHz
V_{IH}^{\parallel}	High-level input voltage	All inputs	2	$V_{DD} + 0.3$		V
V_{IL}	Low-level input voltage	All inputs			0.8	V
I_{OH}	High-level output source current, $V_{OH} = 2.4$ V	Output pins Group 1 [*]			– 2	mA
		Output pins Group 2 [*]			– 4	mA
		Output pins Group 3 [*]			– 8	mA
I_{OL}	Low-level output sink current, $V_{OL} = V_{OL\ MAX}$	Output pins Group 1 [*]			2	mA
		Output pins Group 2 [*]			4	mA
		Output pins Group 3 [*]			8	mA
T_A	Free-air temperature	A version	– 40		85	°C
		S version	– 40		125	
T_J	Junction temperature		– 40	25	150	°C
N_f	Flash endurance for the array (Write/erase cycles)	– 40°C to 85°C		10K		cycles

[‡] See the mechanical data package page for thermal resistance values, θ_{JA} (junction-to-ambient), θ_{JC} (junction-to-case), and Ψ_{jt} (junction-to-top of case)

[§] The drive strengths of the EVA PWM pins and the EVB PWM pins are *not* identical.

^{\ddagger} V_{CCA} should not differ from V_{DD} by more than 0.3 V.

[#] For applications that involve millions of power cycles, it is recommended that V_{CCP} be powered after V_{DD} .

^{\parallel} The input buffers used in 240x/240xA are *not* 5-V compatible.

^{*} Primary signals and their groupings:

- Group 1: PWM1–PWM6, T1PWM, T2PWM, CAP1–CAP6, TCLKINA, IOPF6, IOPC1, TCK, TDI, TMS, XF, A0–A15, \overline{RS}
- Group 2: PS/DS/IS, RD, W/R, STRB, R/W, VIS_OE, D0–D15, T3PWM, T4PWM, PWM7–PWM12, CANTX, CANRX, SPICLK, SPISOMI, SPISIMO, SPISTE, EMU0, EMU1, TDO, TMS2
- Group 3: DIRA, DIRB, SCIRXD, SCITXD, XINT1, XINT2, CLKOUT, TCLKINB



**TMS320LF2407A, TMS320LF2406A, TMS320LF2403A, TMS320LF2402A
TMS320LC2406A, TMS320LC2404A, TMS320LC2403A, TMS320LC2402A
DSP CONTROLLERS**

SPRS145L – JULY 2000 – REVISED SEPTEMBER 2007

electrical characteristics over recommended operating free-air temperature ranges (unless otherwise noted)

PARAMETER		TEST CONDITIONS	MIN	TYP	MAX	UNIT	
V _{OH}	High-level output voltage	V _{DD} = 3.0 V, I _{OH} = I _{OHMAX}	2.4		V _{DDO}	V	
		All outputs at 50 μA	V _{DDO} - 0.2				
V _{OL} [†]	Low-level output voltage	I _{OL} = I _{OLMAX}			0.4	V	
I _{IL}	Input current (low level)	V _{DD} = 3.3 V, V _{IN} = 0 V		-10	-16	-30	μA
I _{IH}	Input current (high level)	V _{DD} = 3.3 V, V _{IN} = V _{DD}		10	16	30	μA
I _{OZ}	Leakage current, high-impedance state (off-state)	V _O = V _{DD} or 0 V			±2	μA	
C _i	Input capacitance			2		pF	
C _o	Output capacitance			3		pF	

[†] For group 3 pins, V_{OL} could be up to 0.6 V, when output source current is 8 mA.

current consumption by power-supply pins over recommended operating free-air temperature ranges at 40-MHz CLOCKOUT

PARAMETER	TEST CONDITIONS	DEVICE	MIN	TYP	MAX	UNIT
I _{DD} [†]	A test code running in B0 RAM does the following: 1. Enables clock to all peripherals. 2. Toggles all PWM outputs at 20 kHz. 3. Performs a continuous conversion of all ADC channels. 4. An infinite loop which transmits a character out of SCI and executes MACD instructions. NOTE: All I/O pins are floating.	LF2407A		95	120	mA
		LF2406A		95	120	mA
		LF2403A		95	120	mA
		LF2402A		85	110	mA
		LC2406A		85	110	mA
		LC2404A		85	110	mA
		LC2403A		75	95	mA
		LC2402A		75	95	mA
I _{CCA}		LF2407A		10	22	mA
		LF2406A		10	22	mA
		LF2403A		10	22	mA
		LF2402A		10	22	mA
		LC2406A		10	22	mA
		LC2404A		10	22	mA
		LC2403A		10	22	mA
		LC2402A		10	22	mA

[†] I_{DD} is the current flowing into the V_{DD}, V_{DDO}, and PLLV_{CCA} pins.



**TMS320LF2407A, TMS320LF2406A, TMS320LF2403A, TMS320LF2402A
TMS320LC2406A, TMS320LC2404A, TMS320LC2403A, TMS320LC2402A
DSP CONTROLLERS**

SPRS145L – JULY 2000 – REVISED SEPTEMBER 2007

current consumption by power-supply pins over recommended operating free-air temperature ranges during low-power modes at 40-MHz CLOCKOUT (TMS320LF2407A)

PARAMETER	MODE	TEST CONDITIONS	MIN	TYP	MAX	UNIT
I_{DD}^{\dagger} Operational Current	LPM0	Clock to all peripherals is enabled. No I/O pins are switching.		70	80	mA
I_{CCA} ADC module current				10	22	mA
I_{DD}^{\dagger} Operational Current	LPM1	Clock to all peripherals is disabled. No I/O pins are switching.		35	45	mA
I_{CCA} ADC module current				0	0	mA
I_{DD}^{\dagger} Operational Current	LPM2	Clock to all peripherals is disabled. Flash is powered down. Input clock is disabled. [‡]		200	400	μ A
I_{CCA} ADC module current				0	0	mA

[†] I_{DD} is the current flowing into the V_{DD} , V_{DDO} , and $PLL_{V_{CCA}}$ pins.

[‡] If a quartz crystal or ceramic resonator is used as the clock source, the LPM2 mode shuts down the internal oscillator.

current consumption by power-supply pins over recommended operating free-air temperature ranges during low-power modes at 40-MHz CLOCKOUT (TMS320LF2406A)

PARAMETER	MODE	TEST CONDITIONS	MIN	TYP	MAX	UNIT
I_{DD}^{\dagger} Operational Current	LPM0	Clock to all peripherals is enabled. No I/O pins are switching.		70	80	mA
I_{CCA} ADC module current				10	22	mA
I_{DD}^{\dagger} Operational Current	LPM1	Clock to all peripherals is disabled. No I/O pins are switching.		35	45	mA
I_{CCA} ADC module current				0	0	mA
I_{DD}^{\dagger} Operational Current	LPM2	Clock to all peripherals is disabled. Flash is powered down. Input clock is disabled. [‡]		200	400	μ A
I_{CCA} ADC module current				0	0	mA

[†] I_{DD} is the current flowing into the V_{DD} , V_{DDO} , and $PLL_{V_{CCA}}$ pins.

[‡] If a quartz crystal or ceramic resonator is used as the clock source, the LPM2 mode shuts down the internal oscillator.

current consumption by power-supply pins over recommended operating free-air temperature ranges during low-power modes at 40-MHz CLOCKOUT (TMS320LF2403A)

PARAMETER	MODE	TEST CONDITIONS	MIN	TYP	MAX	UNIT
I_{DD}^{\dagger} Operational Current	LPM0	Clock to all peripherals is enabled. No I/O pins are switching.		70	80	mA
I_{CCA} ADC module current				10	22	mA
I_{DD}^{\dagger} Operational Current	LPM1	Clock to all peripherals is disabled. No I/O pins are switching.		35	45	mA
I_{CCA} ADC module current				0	0	mA
I_{DD}^{\dagger} Operational Current	LPM2	Clock to all peripherals is disabled. Flash is powered down. Input clock is disabled. [‡]		200	400	μ A
I_{CCA} ADC module current				0	0	mA

[†] I_{DD} is the current flowing into the V_{DD} , V_{DDO} , and $PLL_{V_{CCA}}$ pins.

[‡] If a quartz crystal or ceramic resonator is used as the clock source, the LPM2 mode shuts down the internal oscillator.



**TMS320LF2407A, TMS320LF2406A, TMS320LF2403A, TMS320LF2402A
TMS320LC2406A, TMS320LC2404A, TMS320LC2403A, TMS320LC2402A
DSP CONTROLLERS**

SPRS145L – JULY 2000 – REVISED SEPTEMBER 2007

current consumption by power-supply pins over recommended operating free-air temperature ranges during low-power modes at 40-MHz CLOCKOUT (TMS320LF2402A)

PARAMETER	MODE	TEST CONDITIONS	MIN	TYP	MAX	UNIT
I_{DD}^{\dagger} Operational Current	LPM0	Clock to all peripherals is enabled. No I/O pins are switching.	60	70		mA
I_{CCA} ADC module current			10	22		mA
I_{DD}^{\dagger} Operational Current	LPM1	Clock to all peripherals is disabled. No I/O pins are switching.	35	45		mA
I_{CCA} ADC module current			0	0		mA
I_{DD}^{\dagger} Operational Current	LPM2	Clock to all peripherals is disabled. Flash is powered down. Input clock is disabled. [‡]	200	400		μ A
I_{CCA} ADC module current			0	0		mA

[†] I_{DD} is the current flowing into the V_{DD} , V_{DDO} , and PLL_{VCCA} pins.

[‡] If a quartz crystal or ceramic resonator is used as the clock source, the LPM2 mode shuts down the internal oscillator.

current consumption by power-supply pins over recommended operating free-air temperature ranges during low-power modes at 40-MHz CLOCKOUT (TMS320LC2406A)

PARAMETER	MODE	TEST CONDITIONS	MIN	TYP	MAX	UNIT
I_{DD}^{\dagger} Operational Current	LPM0	Clock to all peripherals is enabled. No I/O pins are switching.	50	70		mA
I_{CCA} ADC module current			10	22		mA
I_{DD}^{\dagger} Operational Current	LPM1	Clock to all peripherals is disabled. No I/O pins are switching.	35	45		mA
I_{CCA} ADC module current			0	0		mA
I_{DD}^{\dagger} Operational Current	LPM2	-40°C to 85°C	20	200		μ A
		-40°C to 125°C	20	400		μ A
I_{CCA} ADC module current		Clock to all peripherals is disabled. Input clock is disabled. [‡]	0	0		mA

[†] I_{DD} is the current flowing into the V_{DD} , V_{DDO} , and PLL_{VCCA} pins.

[‡] If a quartz crystal or ceramic resonator is used as the clock source, the LPM2 mode shuts down the internal oscillator.

current consumption by power-supply pins over recommended operating free-air temperature ranges during low-power modes at 40-MHz CLOCKOUT (TMS320LC2404A)

PARAMETER	MODE	TEST CONDITIONS	MIN	TYP	MAX	UNIT
I_{DD}^{\dagger} Operational Current	LPM0	Clock to all peripherals is enabled. No I/O pins are switching.	50	70		mA
I_{CCA} ADC module current			10	22		mA
I_{DD}^{\dagger} Operational Current	LPM1	Clock to all peripherals is disabled. No I/O pins are switching.	35	45		mA
I_{CCA} ADC module current			0	0		mA
I_{DD}^{\dagger} Operational Current	LPM2	-40°C to 85°C	20	200		μ A
		-40°C to 125°C	20	400		μ A
I_{CCA} ADC module current		Clock to all peripherals is disabled. Input clock is disabled. [‡]	0	0		mA

[†] I_{DD} is the current flowing into the V_{DD} , V_{DDO} , and PLL_{VCCA} pins.

[‡] If a quartz crystal or ceramic resonator is used as the clock source, the LPM2 mode shuts down the internal oscillator.



**TMS320LF2407A, TMS320LF2406A, TMS320LF2403A, TMS320LF2402A
TMS320LC2406A, TMS320LC2404A, TMS320LC2403A, TMS320LC2402A
DSP CONTROLLERS**

SPRS145L – JULY 2000 – REVISED SEPTEMBER 2007

current consumption by power-supply pins over recommended operating free-air temperature ranges during low-power modes at 40-MHz CLOCKOUT (TMS320LC2403A)

PARAMETER	MODE	TEST CONDITIONS	MIN	TYP	MAX	UNIT
I_{DD}^{\dagger} Operational Current	LPM0	Clock to all peripherals is enabled. No I/O pins are switching.		50	70	mA
I_{CCA} ADC module current				10	22	mA
I_{DD}^{\dagger} Operational Current	LPM1	Clock to all peripherals is disabled. No I/O pins are switching.		35	45	mA
I_{CCA} ADC module current				0	0	mA
I_{DD}^{\dagger} Operational Current	LPM2	–40°C to 85°C		20	200	μA
		–40°C to 125°C		20	400	μA
I_{CCA} ADC module current		Clock to all peripherals is disabled. Input clock is disabled.‡		0	0	mA

† I_{DD} is the current flowing into the V_{DD} , V_{DDO} , and $PLL_{V_{CCA}}$ pins.

‡ If a quartz crystal or ceramic resonator is used as the clock source, the LPM2 mode shuts down the internal oscillator.

current consumption by power-supply pins over recommended operating free-air temperature ranges during low-power modes at 40-MHz CLOCKOUT (TMS320LC2402A)

PARAMETER	MODE	TEST CONDITIONS	MIN	TYP	MAX	UNIT
I_{DD}^{\dagger} Operational Current	LPM0	Clock to all peripherals is enabled. No I/O pins are switching.		40	60	mA
I_{CCA} ADC module current				10	22	mA
I_{DD}^{\dagger} Operational Current	LPM1	Clock to all peripherals is disabled. No I/O pins are switching.		35	45	mA
I_{CCA} ADC module current				0	0	mA
I_{DD}^{\dagger} Operational Current	LPM2	–40°C to 85°C		20	200	μA
		–40°C to 125°C		20	400	μA
I_{CCA} ADC module current		Clock to all peripherals is disabled. Input clock is disabled.‡		0	0	mA

† I_{DD} is the current flowing into the V_{DD} , V_{DDO} , and $PLL_{V_{CCA}}$ pins.

‡ If a quartz crystal or ceramic resonator is used as the clock source, the LPM2 mode shuts down the internal oscillator.



current consumption graphs

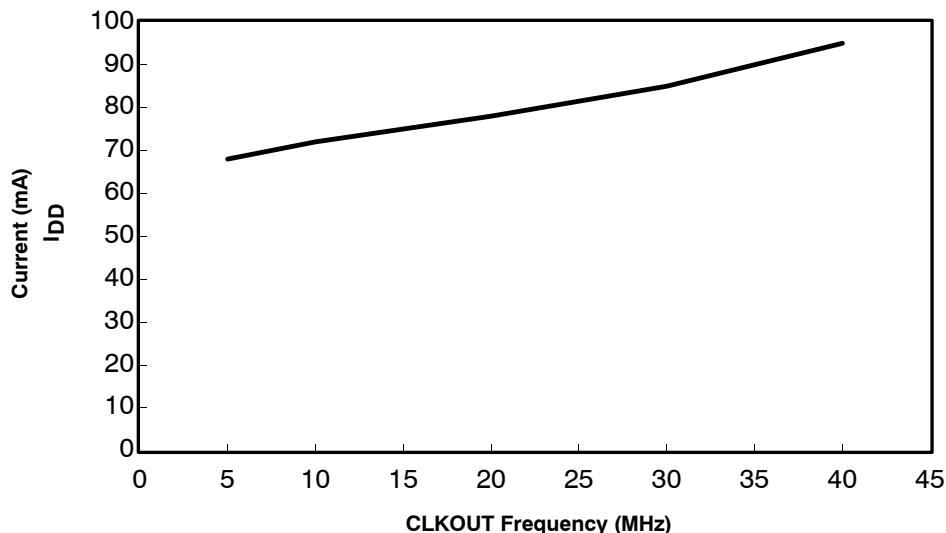

Figure 21. LF2407A Typical Current Consumption (With Peripheral Clocks Enabled)

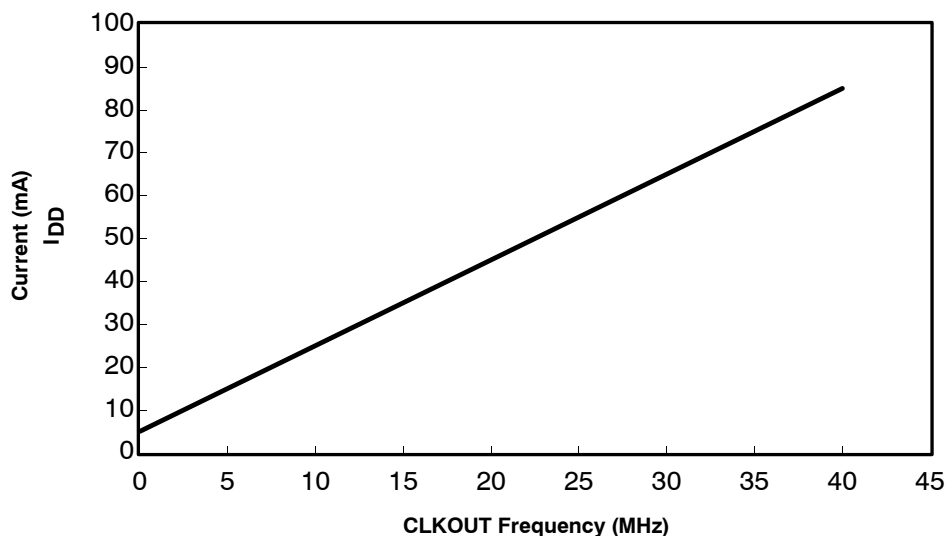

Figure 22. LC2406A Typical Current Consumption (With Peripheral Clocks Enabled)

Figure 23 shows the connection between the DSP and JTAG header for a single-processor configuration. If the distance between the JTAG header and the DSP is greater than 6 inches, the emulation signals must be buffered. If the distance is less than 6 inches, buffering is typically not needed. Figure 23 shows the simpler, no-buffering situation. For the pullup/pulldown resistor values, see the pin description section. For details on buffering JTAG signals and multiple processor connections, see *TMS320F/C24x DSP Controllers CPU and Instruction Set Reference Guide* (literature number SPRU160).

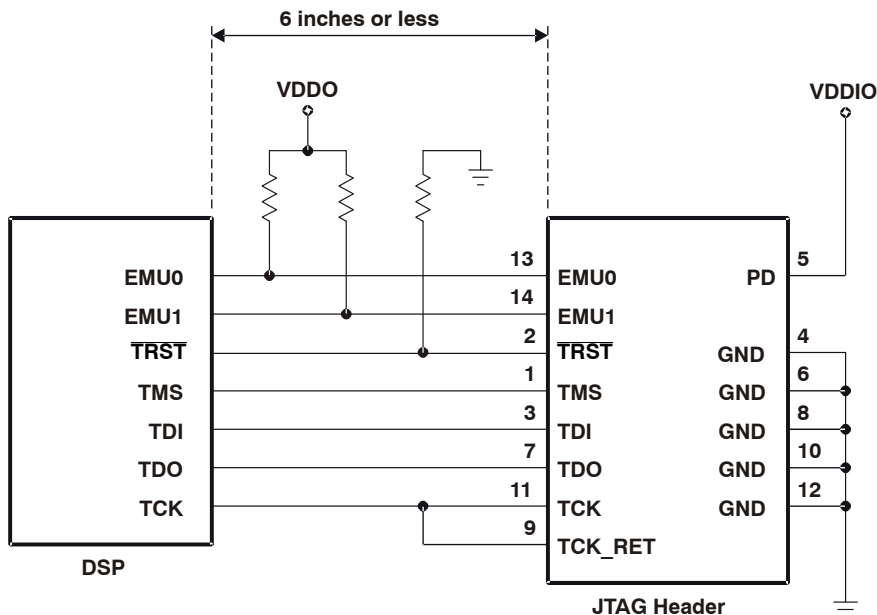

Figure 23. Emulator Connection Without Signal Buffering for the DSP

reducing current consumption

240x DSPs incorporate a unique method to reduce the device current consumption. A reduction in current consumption can be achieved by turning off the clock to any peripheral module which is not used in a given application. Table 17 indicates the typical reduction in current consumption achieved by turning off the clocks to various peripherals. See the *TMS320LF/LC240xA DSP Controllers Reference Guide: System and Peripherals* (literature number SPRU357) for further information on how to turn off the clock to the peripherals.

Table 17. Typical Current Consumption by Various Peripherals (at 40 MHz)

PERIPHERAL MODULE	CURRENT REDUCTION (mA)
CAN	8.4
EVA	6.1
EVB	6.1
ADC	3.7 [†]
SCI	1.9
SPI	1.3

[†] This number represents the current drawn by the digital portion of the ADC module. Turning off the clock to the ADC module results in the elimination of the current drawn by the analog portion of the ADC (I_{CCA}) as well.

PARAMETER MEASUREMENT INFORMATION

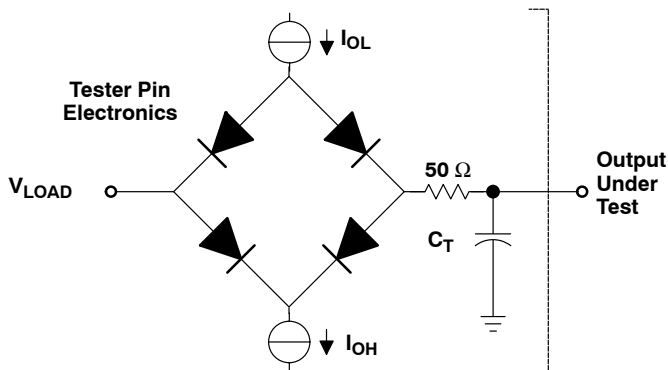

Where: I_{OL} = 2 mA (all outputs)
 I_{OH} = 300 μ A (all outputs)
 V_{LOAD} = 1.5 V
 C_T = 50-pF typical load-circuit capacitance

Figure 24. Test Load Circuit

signal transition levels

The data in this section is shown for the 3.3-V version. Note that some of the signals use different reference voltages, see the recommended operating conditions table. Output levels are driven to a minimum logic-high level of 2.4 V and to a maximum logic-low level of 0.4 V.

Figure 25 shows output levels.

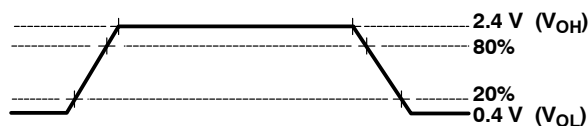

Figure 25. Output Levels

Output transition times are specified as follows:

- For a *high-to-low transition*, the level at which the output is said to be no longer high is below 80% of the total voltage range and lower and the level at which the output is said to be low is 20% of the total voltage range and lower.
- For a *low-to-high transition*, the level at which the output is said to be no longer low is 20% of the total voltage range and higher and the level at which the output is said to be high is 80% of the total voltage range and higher.

Figure 26 shows the input levels.

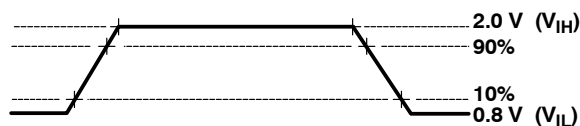

Figure 26. Input Levels

Input transition times are specified as follows:

- For a *high-to-low transition* on an input signal, the level at which the input is said to be no longer high is 90% of the total voltage range and lower and the level at which the input is said to be low is 10% of the total voltage range and lower.
- For a *low-to-high transition* on an input signal, the level at which the input is said to be no longer low is 10% of the total voltage range and higher and the level at which the input is said to be high is 90% of the total voltage range and higher.

PARAMETER MEASUREMENT INFORMATION

timing parameter symbology

Timing parameter symbols used are created in accordance with JEDEC Standard 100. To shorten the symbols, some of the pin names and other related terminology have been abbreviated as follows:

A	A[15:0]	MS	Memory strobe pins \overline{IS} , \overline{DS} , or \overline{PS}
Cl	XTAL1/CLKIN	R	READY
CO	CLKOUT	RD	Read cycle or \overline{RD}
D	D[15:0]	RS	RESET pin \overline{RS}
INT	XINT1, XINT2	W	Write cycle or \overline{WE}

Lowercase subscripts and their meanings:

a	access time
c	cycle time (period)
d	delay time
f	fall time
h	hold time
r	rise time
su	setup time
t	transition time
v	valid time
w	pulse duration (width)

Letters and symbols and their meanings:

H	High
L	Low
V	Valid
X	Unknown, changing, or don't care level
Z	High impedance

general notes on timing

All output signals from the 240xA devices (including CLKOUT) are derived from an internal clock such that all output transitions for a given half-cycle occur with a minimum of skewing relative to each other.

The signal combinations shown in the following timing diagrams may not necessarily represent actual cycles. For actual cycle examples, see the appropriate cycle description section of this data sheet.

**TMS320LF2407A, TMS320LF2406A, TMS320LF2403A, TMS320LF2402A
TMS320LC2406A, TMS320LC2404A, TMS320LC2403A, TMS320LC2402A
DSP CONTROLLERS**

SPRS145L – JULY 2000 – REVISED SEPTEMBER 2007

external reference crystal/clock with PLL circuit enabled

timing parameters with the PLL circuit enabled

PARAMETER		MIN	MAX	UNIT	
f _x	Input clock frequency†	Resonator	4	13	MHz
		Crystal	4	20	
		CLKIN	4	20	

† Input frequency should be adjusted (CLK PS bits in SCSR1 register) such that CLKOUT = 40 MHz maximum, 4 MHz minimum.

switching characteristics over recommended operating conditions [H = 0.5 t_{c(CO)}] (see Figure 27)

PARAMETER	PLL MODE	MIN	TYP	MAX	UNIT
t _{c(CO)}	Cycle time, CLKOUT	×4 mode†	25		ns
t _{f(CO)}	Fall time, CLKOUT		4		ns
t _{r(CO)}	Rise time, CLKOUT		4		ns
t _{w(COL)}	Pulse duration, CLKOUT low	H-3	H	H+3	ns
t _{w(COH)}	Pulse duration, CLKOUT high	H-3	H	H+3	ns
t _t	Transition time, PLL synchronized after RS pin high		4096t _{c(CI)}		ns

† Input frequency should be adjusted (CLK PS bits in SCSR1 register) such that CLKOUT = 40 MHz maximum, 4 MHz minimum.

timing requirements (see Figure 27)

PARAMETER	MIN	MAX	UNIT	
t _{c(CI)}	Cycle time, XTAL1/CLKIN	250	ns	
t _{f(CI)}	Fall time, XTAL1/CLKIN	5	ns	
t _{r(CI)}	Rise time, XTAL1/CLKIN	5	ns	
t _{w(CIL)}	Pulse duration, XTAL1/CLKIN low as a percentage of t _{c(CI)}	40	60	%
t _{w(CIH)}	Pulse duration, XTAL1/CLKIN high as a percentage of t _{c(CI)}	40	60	%

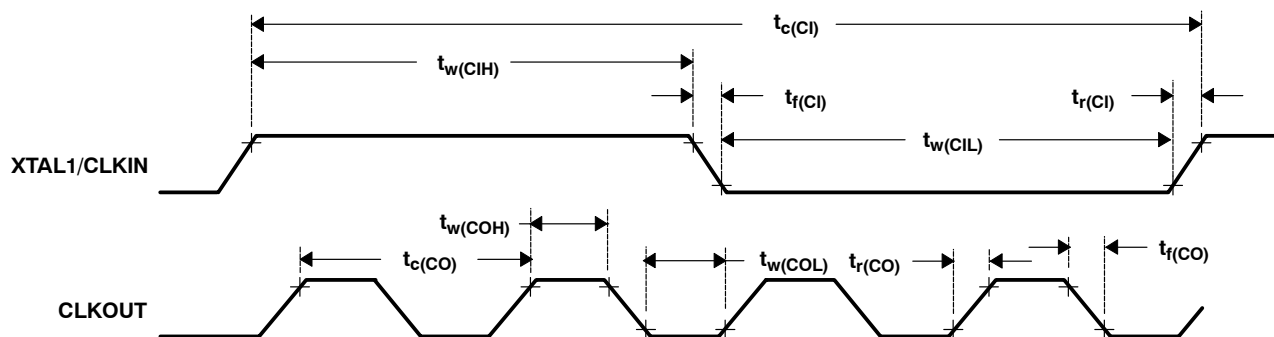

Figure 27. CLKIN-to-CLKOUT Timing with PLL and External Clock in ×4 Mode



\overline{RS} timing

timing requirements for a reset [$H = 0.5t_{c(CO)}$] (see Figure 28 and Figure 29)

		MIN	NOM	MAX	UNIT
$t_{w(RSL)}$	Pulse duration, stable CLKIN to \overline{RS} high	$8t_{c(CI)}$	\dagger		cycles
$t_{w(RSL2)}$	Pulse duration, \overline{RS} low	$8t_{c(CI)}$			cycles
t_p	PLL lock-up time			$4096t_{c(CI)}$	cycles
$t_{d(EX)}$	Delay time, reset vector executed after PLL lock time			36H	ns

\dagger During power-on reset, the device can continue to hold the \overline{RS} pin low for another 128 CLKIN cycles.

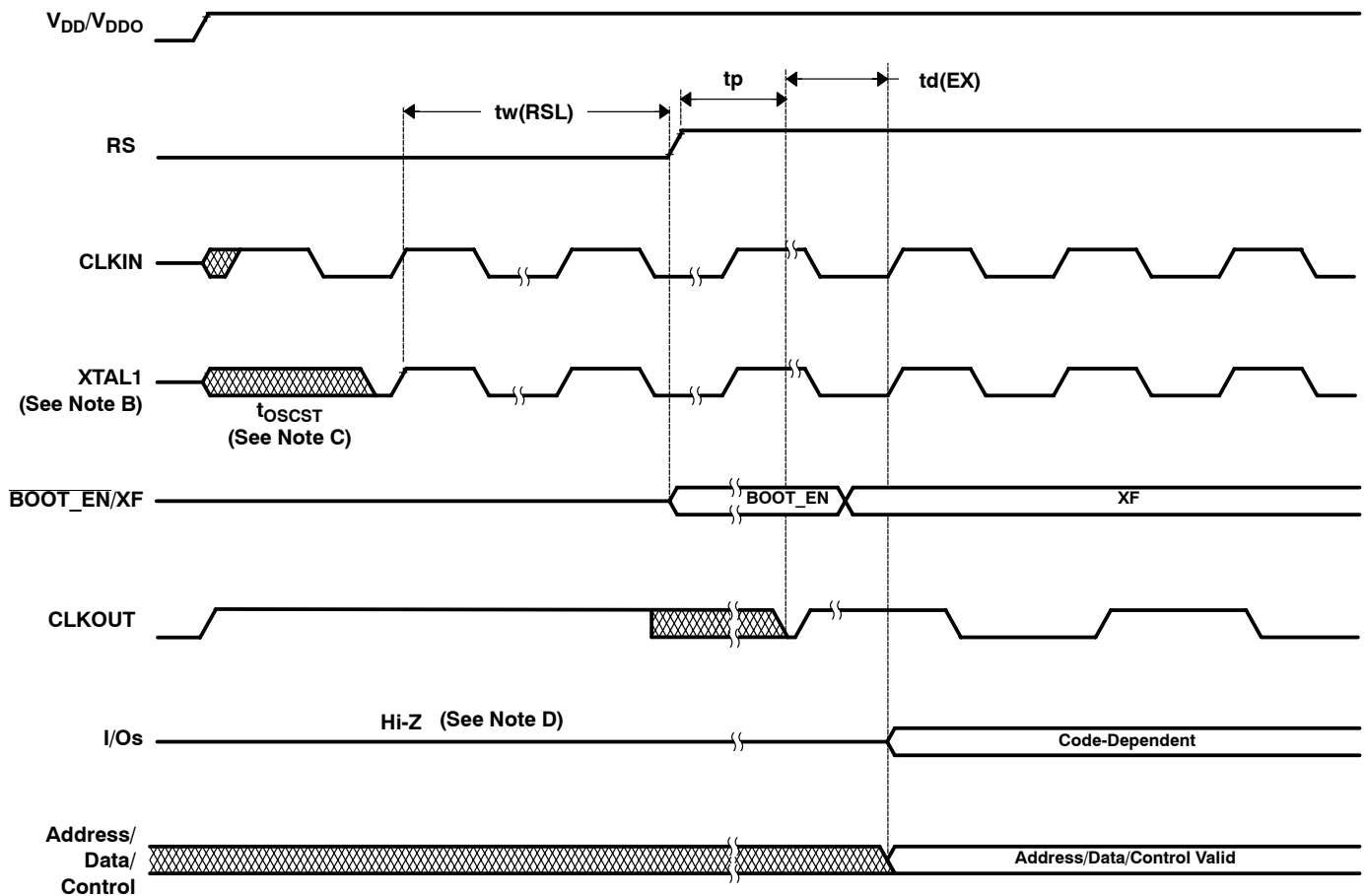

- NOTES: A. Be certain that the emulation logic is reset before de-asserting the device reset. That is, \overline{TRST} of the device is not driven high before the device reset is de-asserted. This is applicable to XDS510™, XDS510PP™, and XDS510PP+™ class of emulators. New generation emulators such as SPI515™ and XDS510 USB™ emulators have built-in protection mechanism to take care of this requirement.
- B. XTAL1 refers to the internal oscillator clock if on-chip oscillator is used.
- C. t_{OSCST} is the oscillator start-up time, which is dependent on crystal/resonator and board design.
- D. All I/Os contain a clamp to V_{DD} . Inputs of approximately 0.7 V above V_{DD} will cause the I/O to sink current. I/Os containing pullups or pulldowns will always sink/source a small amount of current once powered.

Figure 28. Power-on Reset (See Note A)

XDS510PP+, SP515, and XDS510 USB are trademarks of Spectrum Digital.
XDS510 and XDS510PP, are trademarks of Texas Instruments.

**TMS320LF2407A, TMS320LF2406A, TMS320LF2403A, TMS320LF2402A
TMS320LC2406A, TMS320LC2404A, TMS320LC2403A, TMS320LC2402A
DSP CONTROLLERS**

SPRS145L – JULY 2000 – REVISED SEPTEMBER 2007

RS timing (continued)

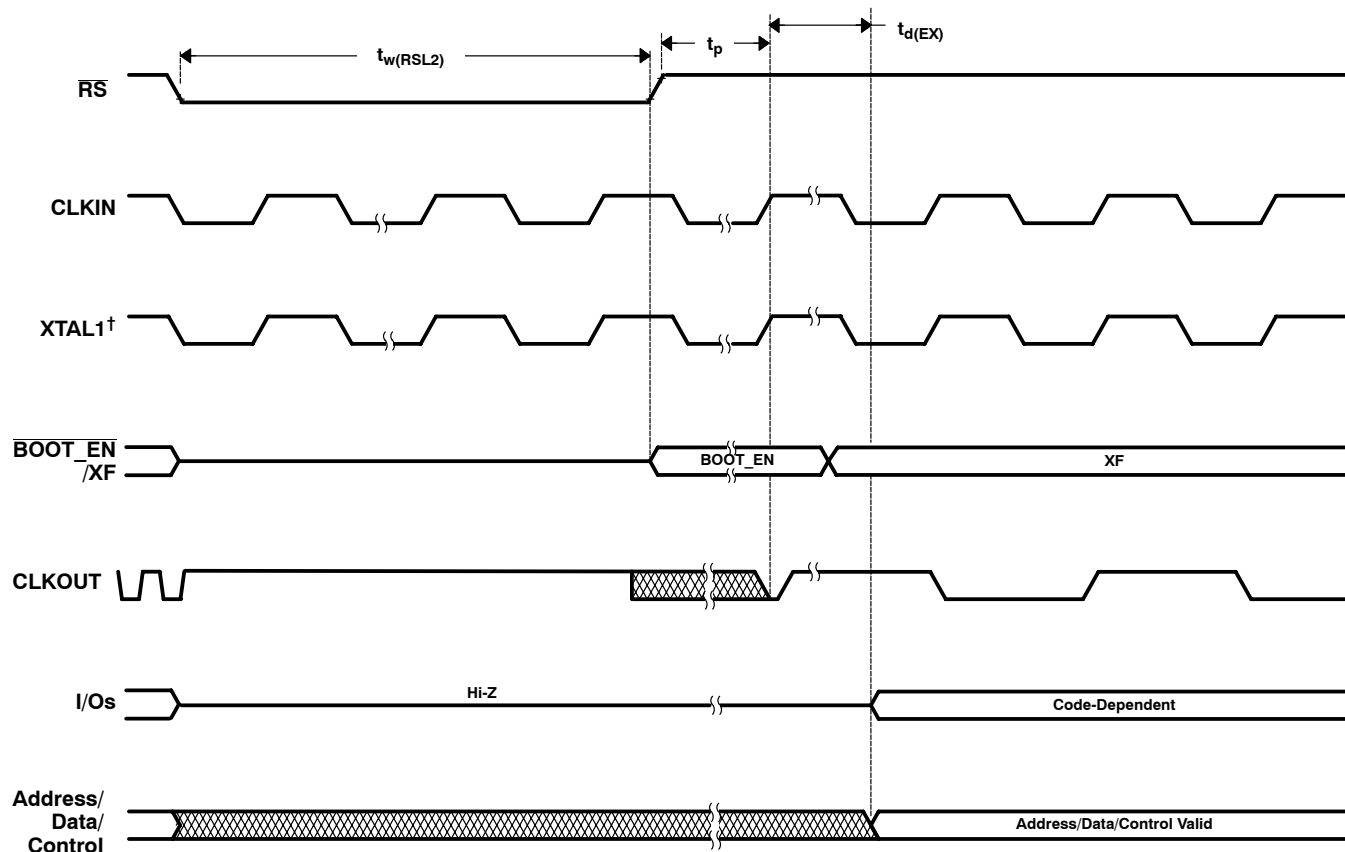

[†] XTAL1 refers to internal oscillator clock if on-chip oscillator is used.

Figure 29. Warm Reset

\overline{RS} timing (continued)

**switching characteristics over recommended operating conditions for a reset [$H = 0.5t_{c(CO)}$]
 (see Figure 30)**

PARAMETER		MIN	MAX	UNIT
$t_{w(RSL1)}$	Pulse duration, \overline{RS} low [†]	$128t_{c(CI)}$		ns
$t_{d(EX)}$	Delay time, reset vector executed after PLL lock time	36H		ns
t_p	PLL lock time (input cycles)		$4096t_{c(CI)}$	ns

[†] The parameter $t_{w(RSL1)}$ refers to the time \overline{RS} is an output.

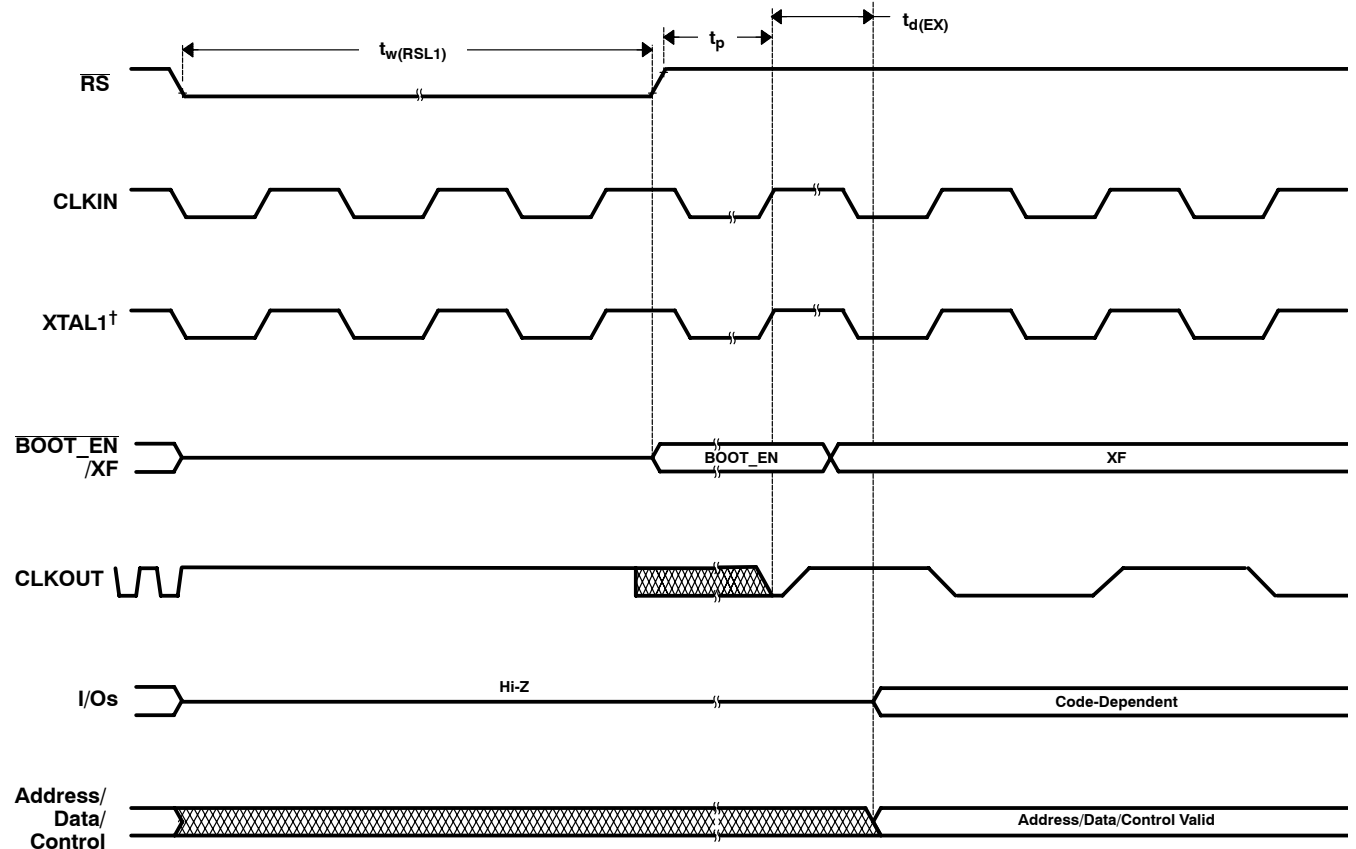

[†] XTAL1 refers to internal oscillator clock if on-chip oscillator is used.

Figure 30. Watchdog Initiated Reset

**TMS320LF2407A, TMS320LF2406A, TMS320LF2403A, TMS320LF2402A
TMS320LC2406A, TMS320LC2404A, TMS320LC2403A, TMS320LC2402A
DSP CONTROLLERS**

SPRS145L – JULY 2000 – REVISED SEPTEMBER 2007

low-power mode timing

**switching characteristics over recommended operating conditions [H = 0.5t_{c(CO)}]
(see Figure 31, Figure 32, and Figure 33)**

PARAMETER		LOW-POWER MODES		MIN	TYP	MAX	UNIT
t _{d(WAKE-A)}	Delay time, CLKOUT switching to program execution resume	IDLE1	LPM0		12 × t _{c(CO)}		ns
		IDLE2	LPM1		15 × t _{c(CO)}		
t _{d(IDLE-COH)}	Delay time, Idle instruction executed to CLKOUT high	IDLE2	LPM1		4t _{c(CO)}		ns
t _{d(WAKE-OSC)}	Delay time, wakeup interrupt asserted to oscillator running	HALT {PLL/OSC power down}	LPM2		OSC start-up time		ms
t _{d(IDLE-OSC)}	Delay time, Idle instruction executed to oscillator power off				4t _{c(CO)}		ns
t _{d(EX)}	Delay time, reset vector executed after PLL lock time			36H			ns

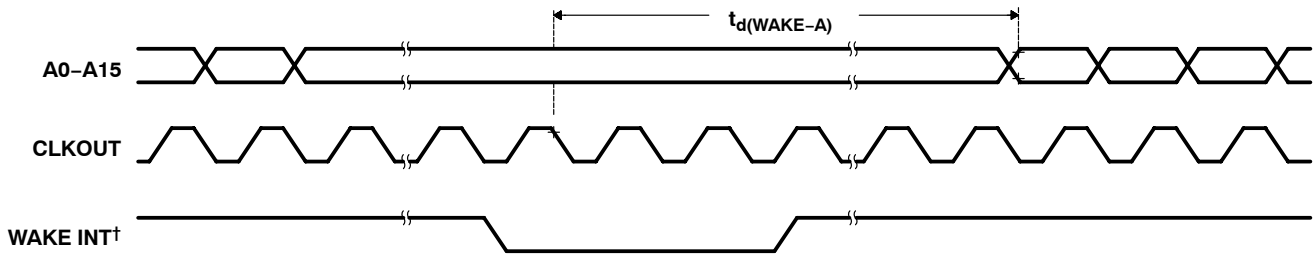

† WAKE INT can be any valid interrupt or RESET.

Figure 31. IDLE1 Entry and Exit Timing – LPM0

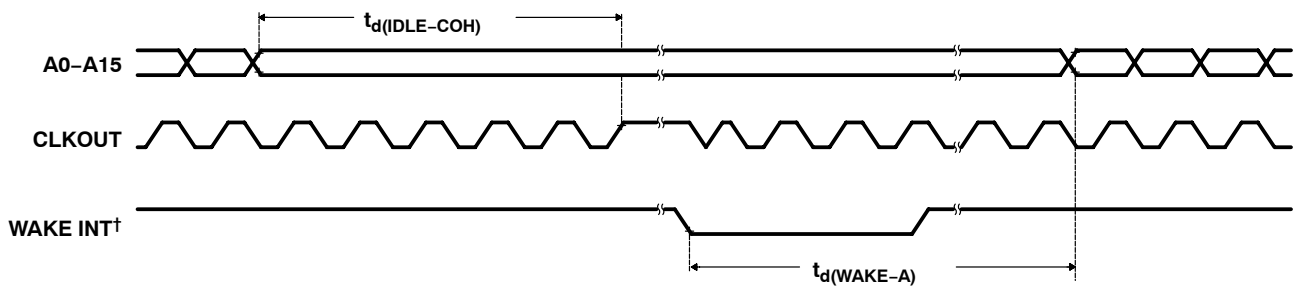

† WAKE INT can be any valid interrupt or RESET.

Figure 32. IDLE2 Entry and Exit Timing – LPM1

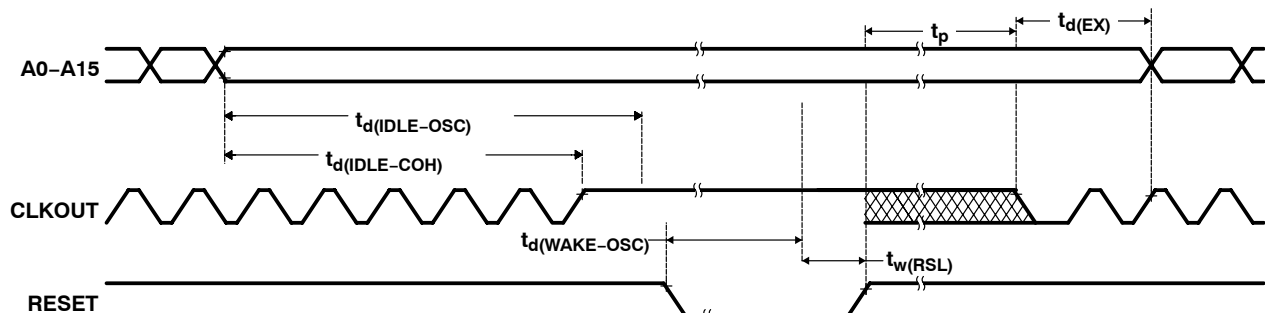

Figure 33. HALT Mode – LPM2



LPM2 wakeup timing

switching characteristics over recommended operating conditions (see Figure 34)

PARAMETER		MIN	MAX	UNIT
$t_{d(PDP-PWM)HZ}$	Delay time, PDPINTA low to PWM high-impedance state	if bit 6 of SCSR2 = 0	$(6 + 1)t_{c(CO)} + 12^{\dagger}$	ns
		if bit 6 of SCSR2 = 1	$(12 + 1)t_{c(CO)} + 12^{\dagger}$	ns
$t_{d(INT)}$	Delay time, INT low/high to interrupt-vector fetch	$10t_{c(CO)} + t_w(PDP-WAKE)$		ns

[†] Includes i/p qualifier cycles plus synchronization plus propagation delay

timing requirements (see Figure 34)

		MIN	MAX	UNIT
$t_w(PDP-WAKE)^{\ddagger}$	Pulse duration, PDPINTA input low	if bit 6 of SCSR2 = 0	$6t_{c(CO)}$	ns
		if bit 6 of SCSR2 = 1	$12t_{c(CO)}$	
t_p	PLL lock-up time	$4096t_{c(CI)}$		cycles

[‡] This is different from 240x devices.

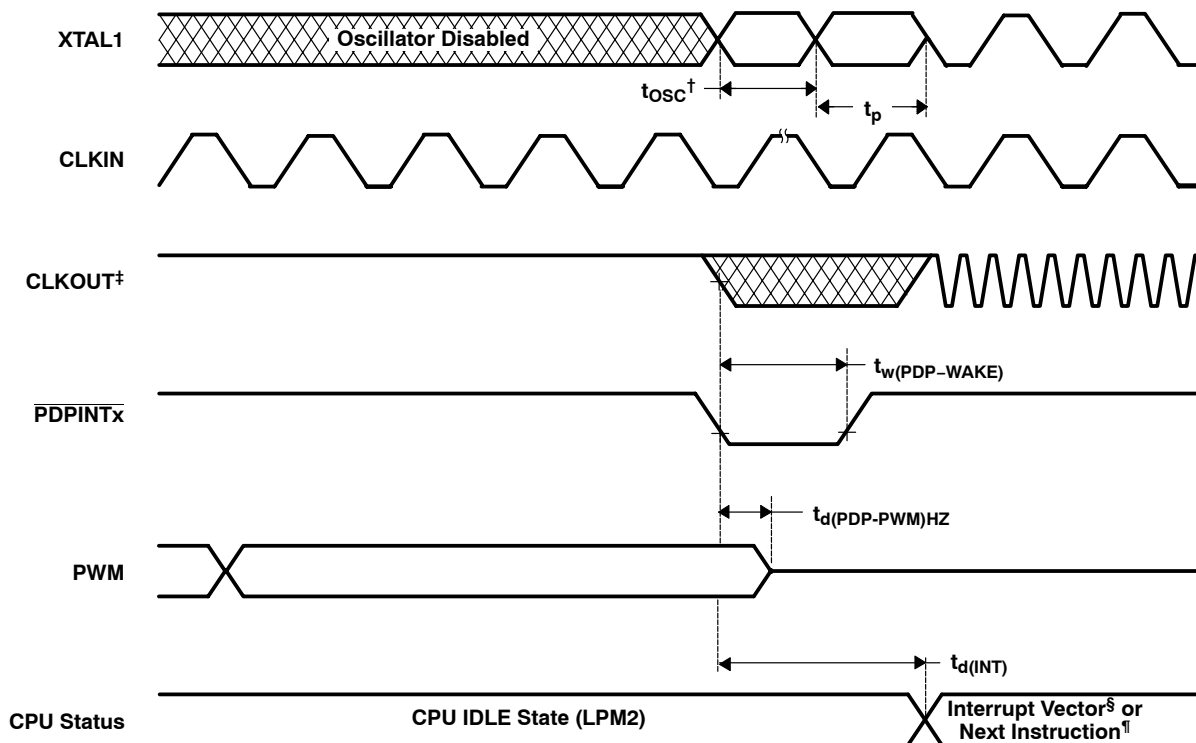

[†] t_{OSC} is the oscillator start-up time.

[‡] CLKOUT frequency after LPM2 wakeup will be the same as that upon entering LPM2 (x4 shown as an example).

[§] PDPINTx interrupt vector, if PDPINTx interrupt is enabled.

[¶] If PDPINTx interrupt is disabled.

Figure 34. LPM2 Wakeup Using PDPINTx

**TMS320LF2407A, TMS320LF2406A, TMS320LF2403A, TMS320LF2402A
TMS320LC2406A, TMS320LC2404A, TMS320LC2403A, TMS320LC2402A
DSP CONTROLLERS**

SPRS145L – JULY 2000 – REVISED SEPTEMBER 2007

XF, $\overline{\text{BIO}}$, and MP/ $\overline{\text{MC}}$ timing

switching characteristics over recommended operating conditions (see Figure 35)

PARAMETER		MIN	MAX	UNIT
$t_{d(XF)}$	Delay time, CLKOUT high to XF high/low	-3	7	ns

timing requirements (see Figure 35)

		MIN	MAX	UNIT
$t_{su(BIO)CO}$	Setup time, $\overline{\text{BIO}}$ or MP/ $\overline{\text{MC}}$ low before CLKOUT low	0		ns
$t_{h(BIO)CO}$	Hold time, $\overline{\text{BIO}}$ or MP/ $\overline{\text{MC}}$ low after CLKOUT low	19		ns

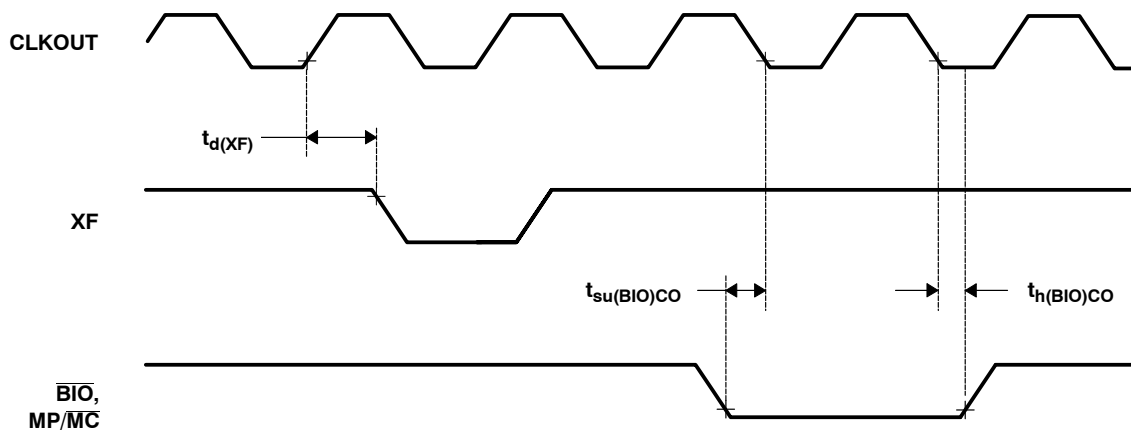

Figure 35. XF and $\overline{\text{BIO}}$ Timing

TIMING EVENT MANAGER INTERFACE

PWM timing

PWM refers to all PWM outputs on EVA and EVB.

**switching characteristics over recommended operating conditions for PWM timing
[H = 0.5t_{c(CO)}] (see Figure 36)**

PARAMETER		MIN	MAX	UNIT
t _{w(PWM)} [†]	Pulse duration, PWMx output high/low	2H+5		ns
t _{d(PWM)CO}	Delay time, CLKOUT low to PWMx output switching		15	ns

[†] PWM outputs may be 100%, 0%, or increments of t_{c(CO)} with respect to the PWM period.

timing requirements[‡] [H = 0.5t_{c(CO)}] (see Figure 37)

		MIN	MAX	UNIT
t _{w(TMRDIR)}	Pulse duration, TMRDIR low/high	4H+5		ns
t _{w(TMRCLK)}	Pulse duration, TMRCLK low as a percentage of TMRCLK cycle time	40	60	%
t _{wh(TMRCLK)}	Pulse duration, TMRCLK high as a percentage of TMRCLK cycle time	40	60	%
t _{c(TMRCLK)}	Cycle time, TMRCLK	4 × t _{c(CO)}		ns

[‡] Parameter TMRDIR is equal to the pin TDIRx, and parameter TMRCLK is equal to the pin TCLKINx.

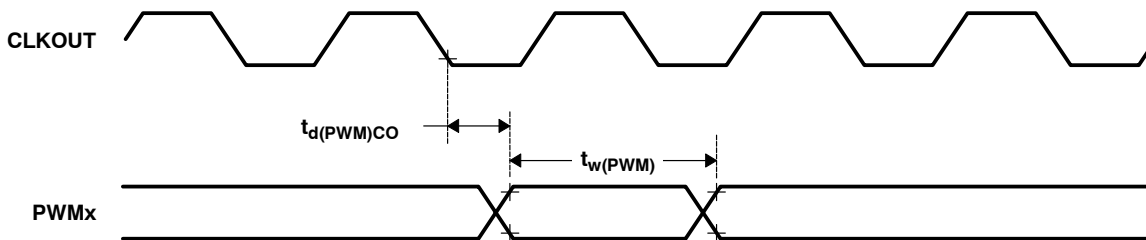
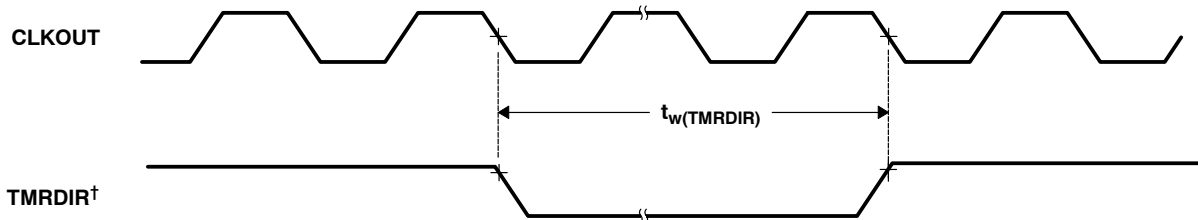

Figure 36. PWM Output Timing



[†] Parameter TMRDIR is equal to the pin TDIRx.

Figure 37. TMRDIR Timing

**TMS320LF2407A, TMS320LF2406A, TMS320LF2403A, TMS320LF2402A
TMS320LC2406A, TMS320LC2404A, TMS320LC2403A, TMS320LC2402A
DSP CONTROLLERS**

SPRS145L – JULY 2000 – REVISED SEPTEMBER 2007

capture and QEP timing

CAP refers to all QEP and capture input pins.

timing requirements (see Figure 38)

		MIN	MAX	UNIT
$t_{w(CAP)}^\dagger$	Pulse duration, CAPx input low/high	if bit 6 of SCSR2 = 0	$6t_{c(CO)}$	ns
		if bit 6 of SCSR2 = 1	$12t_{c(CO)}$	

[†] This is different from 240x devices.

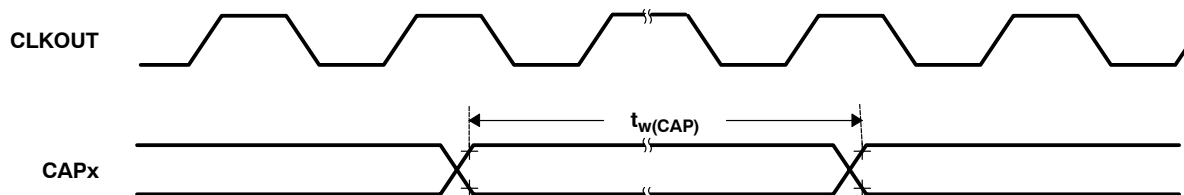

Figure 38. Capture Input and QEP Timing

interrupt timing

INT refers to XINT1 and XINT2. PDP refers to $\overline{\text{PDPINTx}}$.

switching characteristics over recommended operating conditions (see Figure 39)

PARAMETER		MIN	MAX	UNIT
$t_{d(\text{PDP-PWM})\text{HZ}}$	Delay time, $\overline{\text{PDPINTA}}$ low to PWM high-impedance state	if bit 6 of SCSR2 = 0	$(6 + 1)t_{c(\text{CO})} + 12^\dagger$	ns
		if bit 6 of SCSR2 = 1	$(12 + 1)t_{c(\text{CO})} + 12^\dagger$	ns
$t_{d(\text{INT})}$	Delay time, INT low/high to interrupt-vector fetch	$10t_{c(\text{CO})} + t_w(\text{INT})$		ns

[†] Includes i/p qualifier cycles plus synchronization plus propagation delay

timing requirements (see Figure 39)

		MIN	MAX	UNIT
$t_{w(\text{INT})}^\dagger$	Pulse duration, INT input low/high	if bit 6 of SCSR2 = 0	$6t_{c(\text{CO})}$	ns
		if bit 6 of SCSR2 = 1	$12t_{c(\text{CO})}$	
$t_{w(\text{PDP})}^\dagger$	Pulse duration, $\overline{\text{PDPINTx}}$ input low	if bit 6 of SCSR2 = 0	$6t_{c(\text{CO})}$	ns
		if bit 6 of SCSR2 = 1	$12t_{c(\text{CO})}$	

[†] This is different from 240x devices.

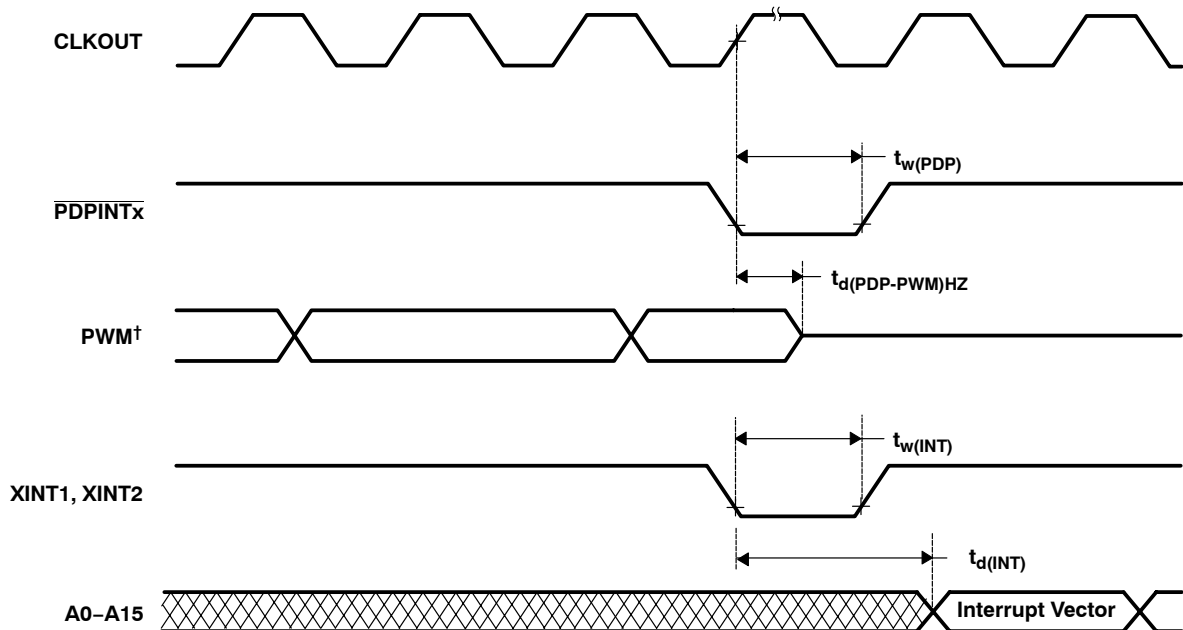

[†] PWM refers to all the PWM pins in the device (i.e., PWMn and TnPWM pins). The state of the PWM pins after $\overline{\text{PDPINTx}}$ is taken high depends on the state of the FCOMPOE bit.

Figure 39. External Interrupts Timing

**TMS320LF2407A, TMS320LF2406A, TMS320LF2403A, TMS320LF2402A
TMS320LC2406A, TMS320LC2404A, TMS320LC2403A, TMS320LC2402A
DSP CONTROLLERS**

SPRS145L – JULY 2000 – REVISED SEPTEMBER 2007

general-purpose input/output timing

switching characteristics over recommended operating conditions (see Figure 40)

PARAMETER		MIN	MAX	UNIT
$t_{d(GPO)CO}$	Delay time, CLKOUT low to GPIO low/high		9	ns
$t_{r(GPO)}$	Rise time, GPIO switching low to high		8	ns
$t_{f(GPO)}$	Fall time, GPIO switching high to low		6	ns

timing requirements [$H = 0.5t_{c(CO)}$] (see Figure 41)

		MIN	MAX	UNIT
$t_w(GPI)$	Pulse duration, GPI high/low	$2H+15$		ns

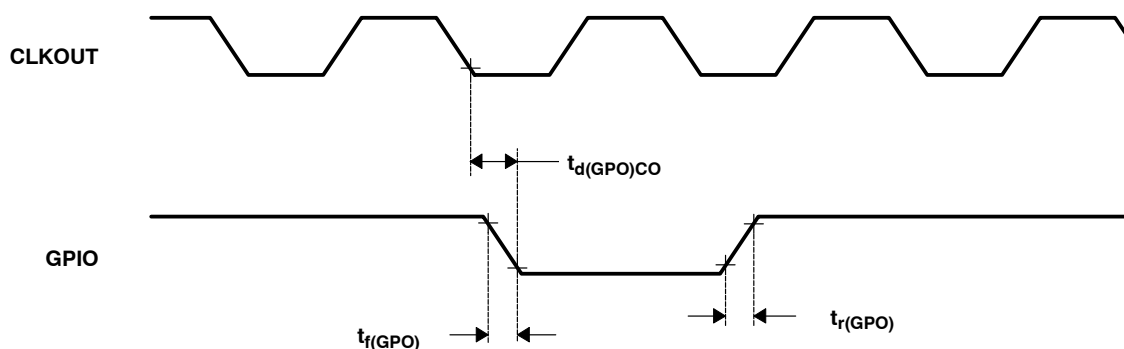

Figure 40. General-Purpose Output Timing

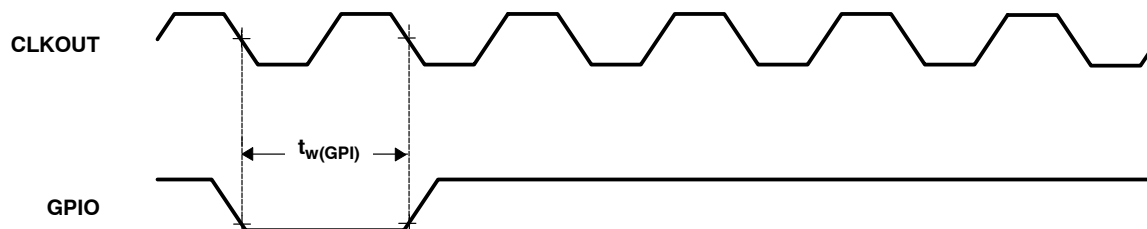

Figure 41. General-Purpose Input Timing

SPI MASTER MODE TIMING PARAMETERS

SPI master mode timing information is listed in the following tables.

SPI master mode external timing parameters (clock phase = 0)^{†‡} (see Figure 42)

NO.		SPI WHEN (SPIBRR + 1) IS EVEN OR SPIBRR = 0 OR 2		SPI WHEN (SPIBRR + 1) IS ODD AND SPIBRR > 3		UNIT
		MIN	MAX	MIN	MAX	
1	$t_{c(SPC)M}$ Cycle time, SPICLK	$4t_{c(CO)}$	$128t_{c(CO)}$	$5t_{c(CO)}$	$127t_{c(CO)}$	ns
2 [§]	$t_{w(SPCH)M}$ Pulse duration, SPICLK high (clock polarity = 0)	$0.5t_{c(SPC)M} - 10$	$0.5t_{c(SPC)M}$	$0.5t_{c(SPC)M} - 0.5t_{c(CO)} - 10$	$0.5t_{c(SPC)M} - 0.5t_{c(CO)}$	ns
	$t_{w(SPCL)M}$ Pulse duration, SPICLK low (clock polarity = 1)	$0.5t_{c(SPC)M} - 10$	$0.5t_{c(SPC)M}$	$0.5t_{c(SPC)M} - 0.5t_{c(CO)} - 10$	$0.5t_{c(SPC)M} - 0.5t_{c(CO)}$	
3 [§]	$t_{w(SPCL)M}$ Pulse duration, SPICLK low (clock polarity = 0)	$0.5t_{c(SPC)M} - 10$	$0.5t_{c(SPC)M}$	$0.5t_{c(SPC)M} + 0.5t_{c(CO)} - 10$	$0.5t_{c(SPC)M} + 0.5t_{c(CO)}$	ns
	$t_{w(SPCH)M}$ Pulse duration, SPICLK high (clock polarity = 1)	$0.5t_{c(SPC)M} - 10$	$0.5t_{c(SPC)M}$	$0.5t_{c(SPC)M} + 0.5t_{c(CO)} - 10$	$0.5t_{c(SPC)M} + 0.5t_{c(CO)}$	
4 [§]	$t_{d(SPCH-SIMO)M}$ Delay time, SPICLK high to SPISIMO valid (clock polarity = 0)	- 10	10	- 10	10	ns
	$t_{d(SPCL-SIMO)M}$ Delay time, SPICLK low to SPISIMO valid (clock polarity = 1)	- 10	10	- 10	10	
5 [§]	$t_{v(SPCL-SIMO)M}$ Valid time, SPISIMO data valid after SPICLK low (clock polarity = 0)	$0.5t_{c(SPC)M} - 10$		$0.5t_{c(SPC)M} + 0.5t_{c(CO)} - 10$		ns
	$t_{v(SPCH-SIMO)M}$ Valid time, SPISIMO data valid after SPICLK high (clock polarity = 1)	$0.5t_{c(SPC)M} - 10$		$0.5t_{c(SPC)M} + 0.5t_{c(CO)} - 10$		
8 [§]	$t_{su(SOMI-SPCL)M}$ Setup time, SPISOMI before SPICLK low (clock polarity = 0)	0		0		ns
	$t_{su(SOMI-SPCH)M}$ Setup time, SPISOMI before SPICLK high (clock polarity = 1)	0		0		
9 [§]	$t_{v(SPCL-SOMI)M}$ Valid time, SPISOMI data valid after SPICLK low (clock polarity = 0)	$0.25t_{c(SPC)M} - 10$		$0.5t_{c(SPC)M} - 0.5t_{c(CO)} - 10$		ns
	$t_{v(SPCH-SOMI)M}$ Valid time, SPISOMI data valid after SPICLK high (clock polarity = 1)	$0.25t_{c(SPC)M} - 10$		$0.5t_{c(SPC)M} - 0.5t_{c(CO)} - 10$		

[†] The MASTER/SLAVE bit (SPICTL.2) is set and the CLOCK PHASE bit (SPICTL.3) is cleared.

[‡] t_c = system clock cycle time = $1/CLKOUT = t_{c(CO)}$

[§] The active edge of the SPICLK signal referenced is controlled by the CLOCK POLARITY bit (SPICCR.6).

PARAMETER MEASUREMENT INFORMATION

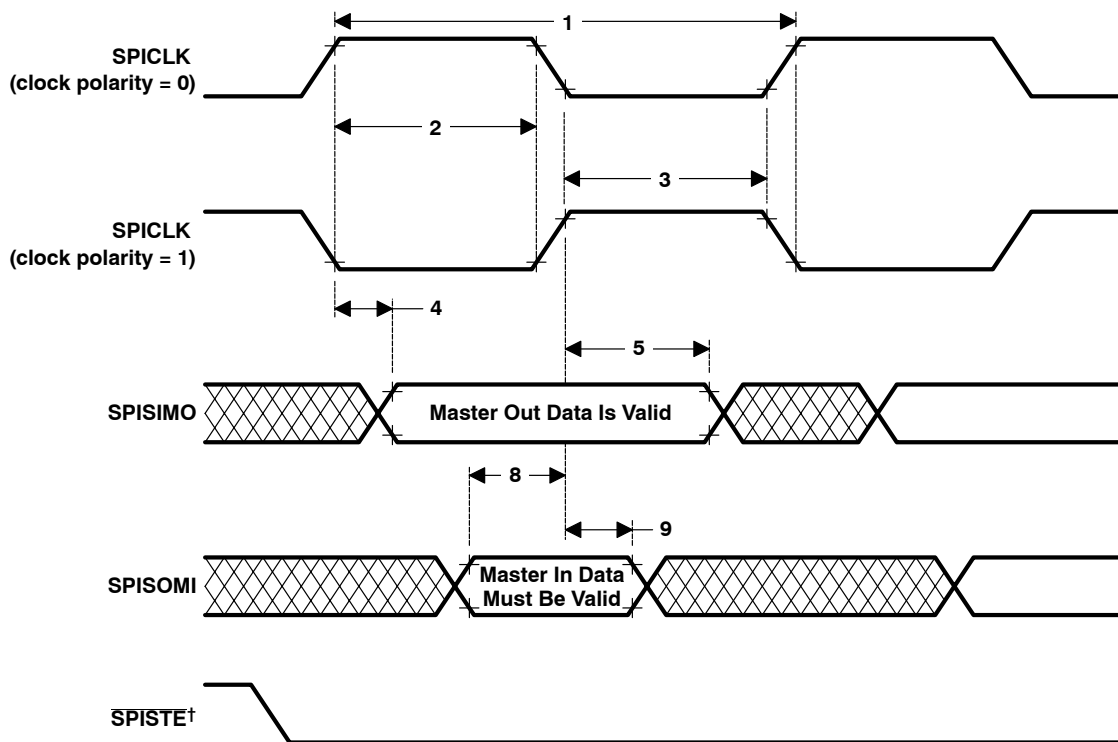

† The $\overline{\text{SPISTE}}$ signal is active before the SPI communication stream starts; the $\overline{\text{SPISTE}}$ signal remains active until the SPI communication stream is complete.

Figure 42. SPI Master Mode External Timing (Clock Phase = 0)

SPI master mode external timing parameters (clock phase = 1)^{†‡} (see Figure 43)

NO.			SPI WHEN (SPIBRR + 1) IS EVEN OR SPIBRR = 0 OR 2		SPI WHEN (SPIBRR + 1) IS ODD AND SPIBRR > 3		UNIT
			MIN	MAX	MIN	MAX	
1	$t_{c(SPC)M}$	Cycle time, SPICLK	$4t_{c(CO)}$	$128t_{c(CO)}$	$5t_{c(CO)}$	$127t_{c(CO)}$	ns
2 [§]	$t_w(SPCH)M$	Pulse duration, SPICLK high (clock polarity = 0)	$0.5t_{c(SPC)M} - 10$	$0.5t_{c(SPC)M}$	$0.5t_{c(SPC)M} - 0.5t_{c(CO)} - 10$	$0.5t_{c(SPC)M} - 0.5t_{c(CO)}$	ns
	$t_w(SPCL)M$	Pulse duration, SPICLK low (clock polarity = 1)	$0.5t_{c(SPC)M} - 10$	$0.5t_{c(SPC)M}$	$0.5t_{c(SPC)M} - 0.5t_{c(CO)} - 10$	$0.5t_{c(SPC)M} - 0.5t_{c(CO)}$	
3 [§]	$t_w(SPCL)M$	Pulse duration, SPICLK low (clock polarity = 0)	$0.5t_{c(SPC)M} - 10$	$0.5t_{c(SPC)M}$	$0.5t_{c(SPC)M} + 0.5t_{c(CO)} - 10$	$0.5t_{c(SPC)M} + 0.5t_{c(CO)}$	ns
	$t_w(SPCH)M$	Pulse duration, SPICLK high (clock polarity = 1)	$0.5t_{c(SPC)M} - 10$	$0.5t_{c(SPC)M}$	$0.5t_{c(SPC)M} + 0.5t_{c(CO)} - 10$	$0.5t_{c(SPC)M} + 0.5t_{c(CO)}$	
6 [§]	$t_{su}(SIMO-SPCH)M$	Setup time, SPISIMO data valid before SPICLK high (clock polarity = 0)	$0.5t_{c(SPC)M} - 10$		$0.5t_{c(SPC)M} - 10$		ns
	$t_{su}(SIMO-SPCL)M$	Setup time, SPISIMO data valid before SPICLK low (clock polarity = 1)	$0.5t_{c(SPC)M} - 10$		$0.5t_{c(SPC)M} - 10$		
7 [§]	$t_v(SPCH-SIMO)M$	Valid time, SPISIMO data valid after SPICLK high (clock polarity = 0)	$0.5t_{c(SPC)M} - 10$		$0.5t_{c(SPC)M} - 10$		ns
	$t_v(SPCL-SIMO)M$	Valid time, SPISIMO data valid after SPICLK low (clock polarity = 1)	$0.5t_{c(SPC)M} - 10$		$0.5t_{c(SPC)M} - 10$		
10 [§]	$t_{su}(SOMI-SPCH)M$	Setup time, SPISOMI before SPICLK high (clock polarity = 0)	0		0		ns
	$t_{su}(SOMI-SPCL)M$	Setup time, SPISOMI before SPICLK low (clock polarity = 1)	0		0		
11 [§]	$t_v(SPCH-SOMI)M$	Valid time, SPISOMI data valid after SPICLK high (clock polarity = 0)	$0.25t_{c(SPC)M} - 10$		$0.5t_{c(SPC)M} - 10$		ns
	$t_v(SPCL-SOMI)M$	Valid time, SPISOMI data valid after SPICLK low (clock polarity = 1)	$0.25t_{c(SPC)M} - 10$		$0.5t_{c(SPC)M} - 10$		

[†] The MASTER/SLAVE bit (SPICTL.2) is set and the CLOCK PHASE bit (SPICTL.3) is set.

[‡] t_c = system clock cycle time = 1/CLKOUT = $t_{c(CO)}$

[§] The active edge of the SPICLK signal referenced is controlled by the CLOCK POLARITY bit (SPICCR.6).

PARAMETER MEASUREMENT INFORMATION

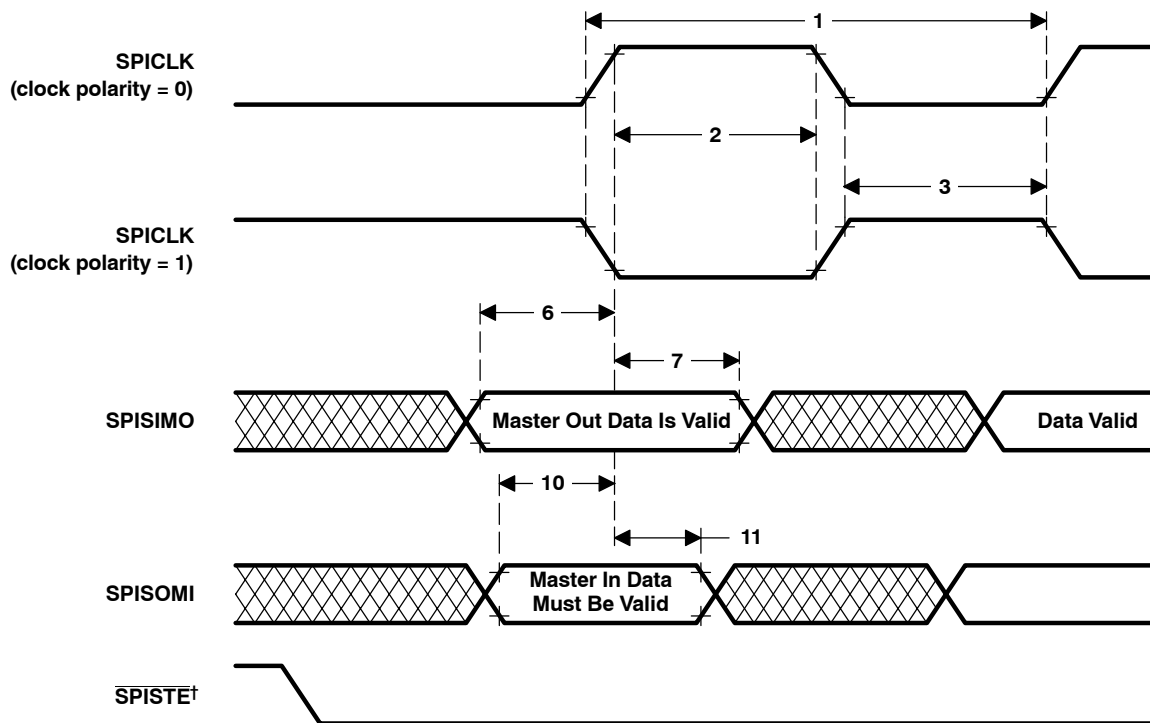

† The $\overline{\text{SPISTE}}$ signal is active before the SPI communication stream starts; the $\overline{\text{SPISTE}}$ signal remains active until the SPI communication stream is complete.

Figure 43. SPI Master Mode External Timing (Clock Phase = 1)

SPI slave mode timing parameters

Slave mode timing information is listed in the following tables.

SPI slave mode external timing parameters (clock phase = 0)^{†‡} (see Figure 44)

NO.			MIN	MAX	UNIT
12	$t_{c(SPC)S}$	Cycle time, SPICLK	$4t_{c(CO)}^{\dagger}$		ns
13 [§]	$t_{w(SPCH)S}$	Pulse duration, SPICLK high (clock polarity = 0)	$0.5t_{c(SPC)S} - 10$	$0.5t_{c(SPC)S}$	ns
	$t_{w(SPCL)S}$	Pulse duration, SPICLK low (clock polarity = 1)	$0.5t_{c(SPC)S} - 10$	$0.5t_{c(SPC)S}$	
14 [§]	$t_{w(SPCL)S}$	Pulse duration, SPICLK low (clock polarity = 0)	$0.5t_{c(SPC)S} - 10$	$0.5t_{c(SPC)S}$	ns
	$t_{w(SPCH)S}$	Pulse duration, SPICLK high (clock polarity = 1)	$0.5t_{c(SPC)S} - 10$	$0.5t_{c(SPC)S}$	
15 [§]	$t_{d(SPCH-SOMI)S}$	Delay time, SPICLK high to SPISOMI valid (clock polarity = 0)	$0.375t_{c(SPC)S} - 10$		ns
	$t_{d(SPCL-SOMI)S}$	Delay time, SPICLK low to SPISOMI valid (clock polarity = 1)	$0.375t_{c(SPC)S} - 10$		
16 [§]	$t_{v(SPCL-SOMI)S}$	Valid time, SPISOMI data valid after SPICLK low (clock polarity = 0)	$0.75t_{c(SPC)S}$		ns
	$t_{v(SPCH-SOMI)S}$	Valid time, SPISOMI data valid after SPICLK high (clock polarity = 1)	$0.75t_{c(SPC)S}$		
19 [§]	$t_{su(SIMO-SPCL)S}$	Setup time, SPISIMO before SPICLK low (clock polarity = 0)	0		ns
	$t_{su(SIMO-SPCH)S}$	Setup time, SPISIMO before SPICLK high (clock polarity = 1)	0		
20 [§]	$t_{v(SPCL-SIMO)S}$	Valid time, SPISIMO data valid after SPICLK low (clock polarity = 0)	$0.5t_{c(SPC)S}$		ns
	$t_{v(SPCH-SIMO)S}$	Valid time, SPISIMO data valid after SPICLK high (clock polarity = 1)	$0.5t_{c(SPC)S}$		

[†] The MASTER/SLAVE bit (SPICTL.2) is cleared and the CLOCK PHASE bit (SPICTL.3) is cleared.

[‡] t_c = system clock cycle time = $1/CLKOUT = t_{c(CO)}$

[§] The active edge of the SPICLK signal referenced is controlled by the CLOCK POLARITY bit (SPICCR.6).

SPI slave mode external timing parameters (continued)

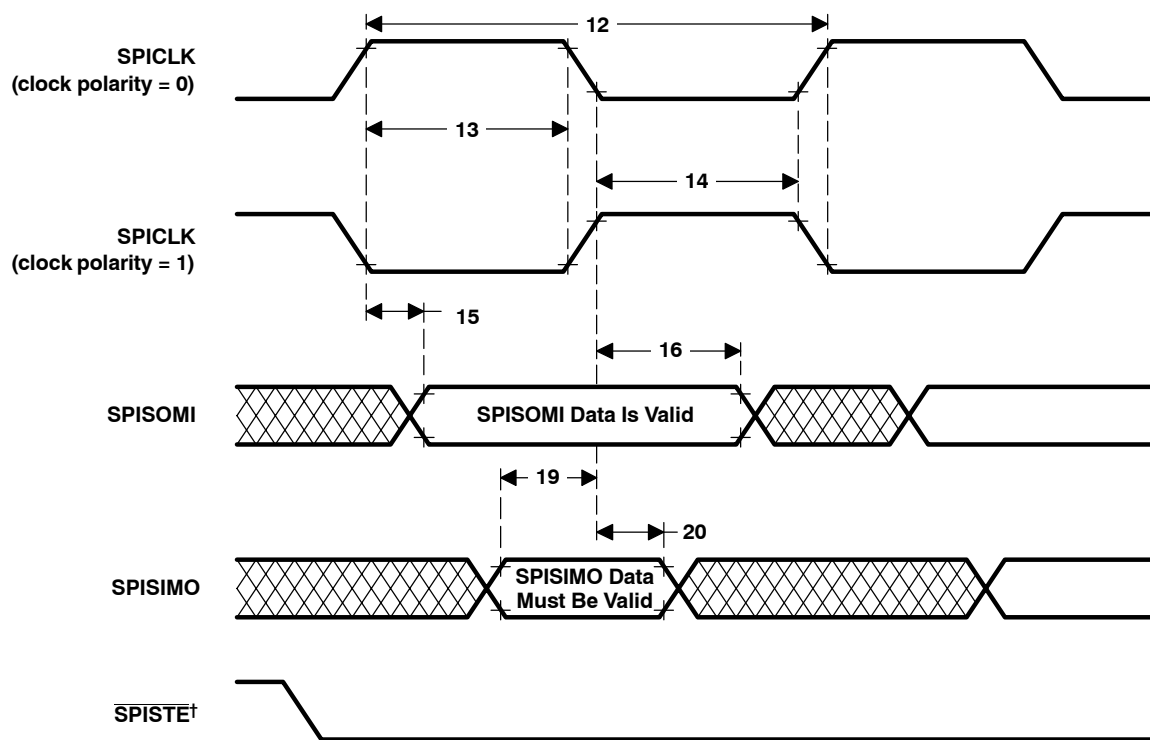

† The $\overline{\text{SPISTEn}}$ signal must be active before the SPI communication stream starts; the $\overline{\text{SPISTEn}}$ signal must remain active until the SPI communication stream is complete.

Figure 44. SPI Slave Mode External Timing (Clock Phase = 0)

SPI slave mode timing parameters (continued)

SPI slave mode external timing parameters (clock phase = 1)^{†‡} (see Figure 45)

NO.			MIN	MAX	UNIT
12	$t_{c(SPC)S}$	Cycle time, SPICLK	$8t_{c(CO)}$		ns
13 [§]	$t_{w(SPCH)S}$	Pulse duration, SPICLK high (clock polarity = 0)	$0.5t_{c(SPC)S} - 10$	$0.5t_{c(SPC)S}$	ns
	$t_{w(SPCL)S}$	Pulse duration, SPICLK low (clock polarity = 1)	$0.5t_{c(SPC)S} - 10$	$0.5t_{c(SPC)S}$	
14 [§]	$t_{w(SPCL)S}$	Pulse duration, SPICLK low (clock polarity = 0)	$0.5t_{c(SPC)S} - 10$	$0.5t_{c(SPC)S}$	ns
	$t_{w(SPCH)S}$	Pulse duration, SPICLK high (clock polarity = 1)	$0.5t_{c(SPC)S} - 10$	$0.5t_{c(SPC)S}$	
17 [§]	$t_{su(SOMI-SPCH)S}$	Setup time, SPISOMI before SPICLK high (clock polarity = 0)	$0.125t_{c(SPC)S}$		ns
	$t_{su(SOMI-SPCL)S}$	Setup time, SPISOMI before SPICLK low (clock polarity = 1)	$0.125t_{c(SPC)S}$		
18 [§]	$t_{v(SPCH-SOMI)S}$	Valid time, SPISOMI data valid after SPICLK high (clock polarity = 0)	$0.75t_{c(SPC)S}$		ns
	$t_{v(SPCL-SOMI)S}$	Valid time, SPISOMI data valid after SPICLK low (clock polarity = 1)	$0.75t_{c(SPC)S}$		
21 [§]	$t_{su(SIMO-SPCH)S}$	Setup time, SPISIMO before SPICLK high (clock polarity = 0)	0		ns
	$t_{su(SIMO-SPCL)S}$	Setup time, SPISIMO before SPICLK low (clock polarity = 1)	0		
22 [§]	$t_{v(SPCH-SIMO)S}$	Valid time, SPISIMO data valid after SPICLK high (clock polarity = 0)	$0.5t_{c(SPC)S}$		ns
	$t_{v(SPCL-SIMO)S}$	Valid time, SPISIMO data valid after SPICLK low (clock polarity = 1)	$0.5t_{c(SPC)S}$		

[†] The MASTER/SLAVE bit (SPICTL.2) is cleared and the CLOCK PHASE bit (SPICTL.3) is set.

[‡] t_c = system clock cycle time = 1/CLKOUT = $t_{c(CO)}$

[§] The active edge of the SPICLK signal referenced is controlled by the CLOCK POLARITY bit (SPICCR.6).

**TMS320LF2407A, TMS320LF2406A, TMS320LF2403A, TMS320LF2402A
TMS320LC2406A, TMS320LC2404A, TMS320LC2403A, TMS320LC2402A
DSP CONTROLLERS**

SPRS145L – JULY 2000 – REVISED SEPTEMBER 2007

SPI slave mode timing parameters (continued)

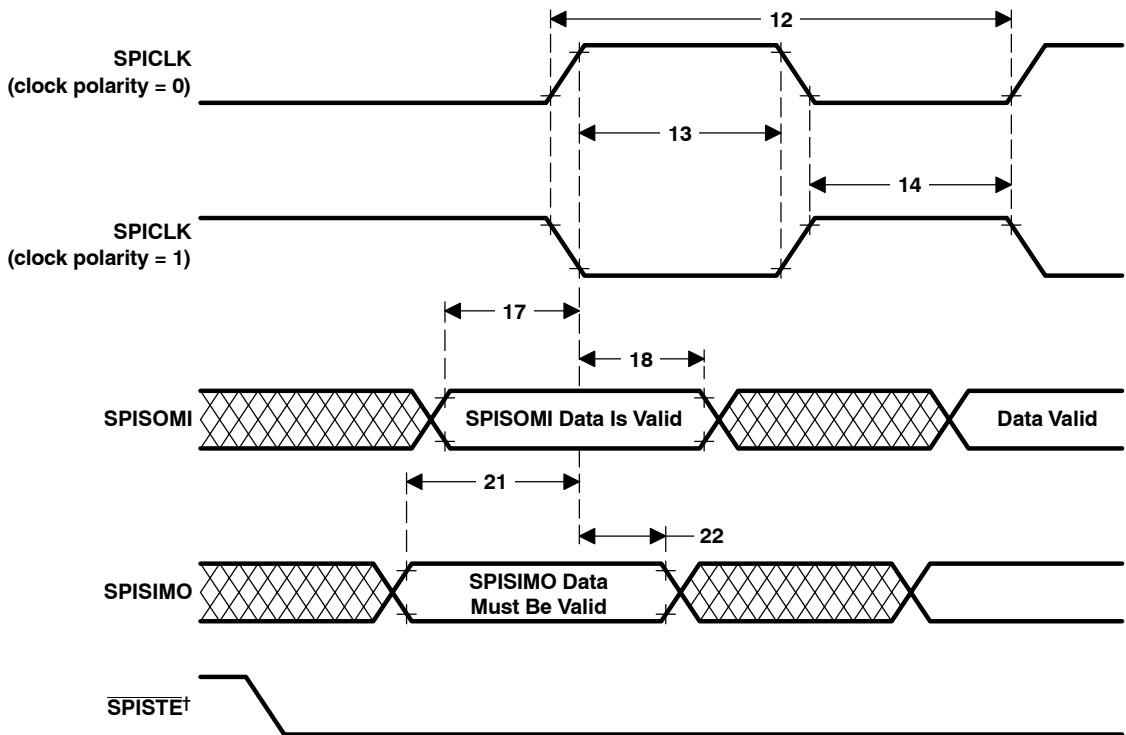

† The $\overline{\text{SPISTE}}$ signal must be active before the SPI communication stream starts; the $\overline{\text{SPISTE}}$ signal must remain active until the SPI communication stream is complete.

Figure 45. SPI Slave Mode External Timing (Clock Phase = 1)

external memory interface *read* timing

switching characteristics over recommended operating conditions for an external memory interface read at 40 MHz [$H = 0.5t_c(CO)$] (see Figure 46)

PARAMETER		MIN	MAX	UNIT
$t_{d(COL-CNTL)}$	Delay time, CLKOUT low to control valid		4	ns
$t_{d(COL-CNTH)}$	Delay time, CLKOUT low to control inactive		5	ns
$t_{d(COL-A)RD}$	Delay time, CLKOUT low to address valid		8	ns
$t_{d(COH-RDL)}$	Delay time, CLKOUT high to \overline{RD} strobe active		5	ns
$t_{d(COL-RDH)}$	Delay time, CLKOUT low to \overline{RD} strobe inactive high	-8	1	ns
$t_{d(COL-SL)}$	Delay time, CLKOUT low to \overline{STRB} strobe active low		5	ns
$t_{d(COL-SH)}$	Delay time, CLKOUT low to \overline{STRB} strobe inactive high		6	ns
$t_{d(WRN)}$	Delay time, W/\overline{R} going low to R/\overline{W} rising		5	ns
$t_{h(A)COL}$	Hold time, address valid after CLKOUT low	2		ns
$t_{su(A)RD}$	Setup time, address valid before \overline{RD} strobe active low	H - 7		ns
$t_{h(A)RD}$	Hold time, address valid after \overline{RD} strobe inactive high	0		ns

timing requirements [$H = 0.5t_c(CO)$] (see Figure 46)

		MIN	MAX	UNIT
$t_{a(A)}$	Access time, read data from address valid		2H - 10	ns
$t_{a(RD)}$	Access time, read data from \overline{RD} low		H - 7	ns
$t_{su(D)RD}$	Setup time, read data before \overline{RD} strobe inactive high	8		ns
$t_{h(D)RD}$	Hold time, read data after \overline{RD} strobe inactive high	0		ns
$t_{h(AIV-D)}$	Hold time, read data after address invalid	0		ns

**TMS320LF2407A, TMS320LF2406A, TMS320LF2403A, TMS320LF2402A
TMS320LC2406A, TMS320LC2404A, TMS320LC2403A, TMS320LC2402A
DSP CONTROLLERS**

SPRS145L – JULY 2000 – REVISED SEPTEMBER 2007

external memory interface read timing (continued)

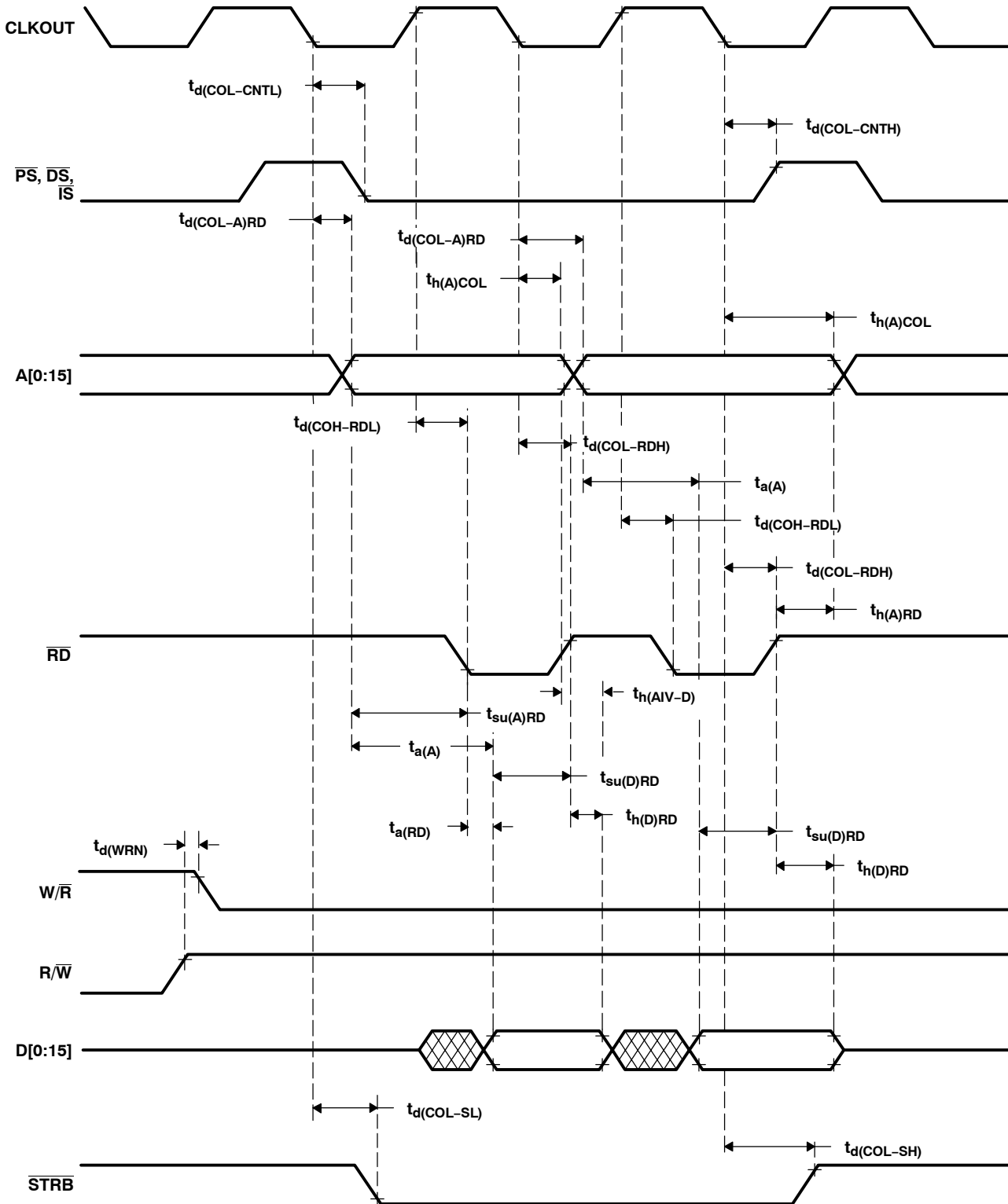

Figure 46. Memory Interface Read/Read Timings



**TMS320LF2407A, TMS320LF2406A, TMS320LF2403A, TMS320LF2402A
TMS320LC2406A, TMS320LC2404A, TMS320LC2403A, TMS320LC2402A
DSP CONTROLLERS**

SPRS145L – JULY 2000 – REVISED SEPTEMBER 2007

external memory interface *write* timing

switching characteristics over recommended operating conditions for an external memory interface write at 40 MHz [$H = 0.5t_{c(CO)}$] (see Figure 47)

PARAMETER		MIN	MAX	UNIT
$t_{d(COH-CNTL)}$	Delay time, CLKOUT high to control valid		4	ns
$t_{d(COH-CNTH)}$	Delay time, CLKOUT high to control inactive		5	ns
$t_{d(COH-A)W}$	Delay time, CLKOUT high to address valid		10	ns
$t_{d(COH-RWL)}$	Delay time, CLKOUT high to R/W low		6	ns
$t_{d(COH-RWH)}$	Delay time, CLKOUT high to R/W high		6	ns
$t_{d(COL-WL)}$	Delay time, CLKOUT low to \overline{WE} strobe active low		6	ns
$t_{d(COL-WH)}$	Delay time, CLKOUT low to \overline{WE} strobe inactive high		6	ns
$t_{en(D)COL}$	Enable time, data bus driven from CLKOUT low	-3		ns
$t_{d(COL-SL)}$	Delay time, CLKOUT low to \overline{STRB} active low		6	ns
$t_{d(COL-SH)}$	Delay time, CLKOUT low to \overline{STRB} inactive high		6	ns
$t_{d(WRN)}$	Delay time, R/W rising to W/R going low		5	ns
$t_{h(A)COLW}$	Hold time, address valid after CLKOUT low	-5		ns
$t_{su(A)W}$	Setup time, address valid before \overline{WE} strobe active low	H-9		ns
$t_{su(D)W}$	Setup time, write data before \overline{WE} strobe inactive high	2H-17		ns
$t_{h(D)W}$	Hold time, write data after \overline{WE} strobe inactive high	2		ns
$t_{dis(W-D)}$	Disable time, data bus high impedance from \overline{WE} high	5		ns

**TMS320LF2407A, TMS320LF2406A, TMS320LF2403A, TMS320LF2402A
TMS320LC2406A, TMS320LC2404A, TMS320LC2403A, TMS320LC2402A
DSP CONTROLLERS**

SPRS145L – JULY 2000 – REVISED SEPTEMBER 2007

external memory interface write timing (continued)

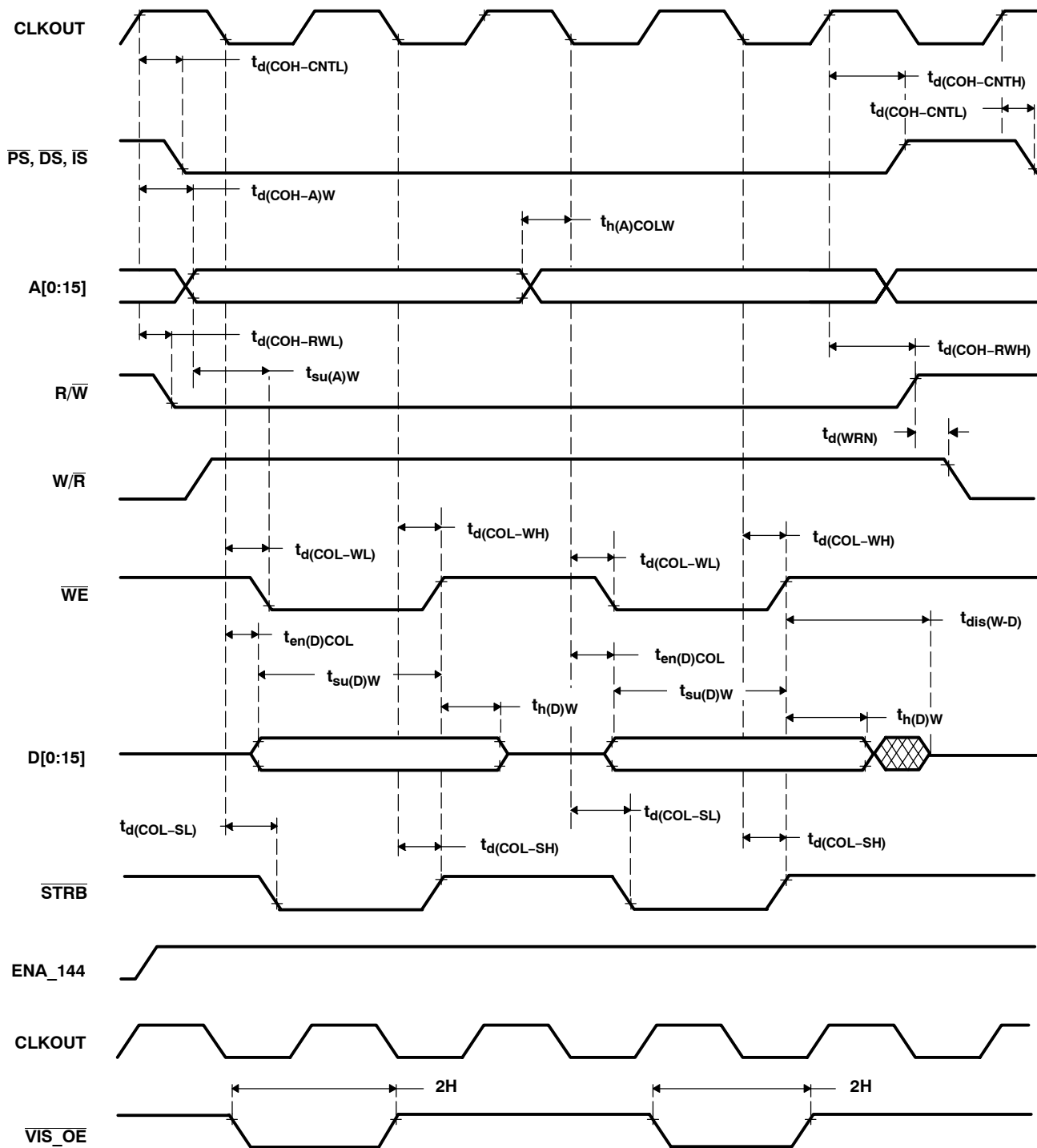

NOTE A: $\overline{\text{VIS_OE}}$ will be visible at pin 97 of LF2407A when ENA_144 is high along with BVIS bits (10,9 of WSGR register – FFFFh@I/O) set to 10 or 11. CLKOUT and $\overline{\text{VIS_OE}}$ indicate internal memory write cycles (program/data). During $\overline{\text{VIS_OE}}$ cycles, the external bus will be driven. CLKOUT is to be used along with $\overline{\text{VIS_OE}}$ for trace capabilities.

Figure 47. Memory Interface Write/Write Timings

external memory interface *ready-on-read* timing

switching characteristics over recommended operating conditions for an external memory interface ready-on-read (see Figure 48)

PARAMETER		MIN	MAX	UNIT
$t_{d(COL-A)RD}$	Delay time, CLKOUT low to address valid		8	ns

timing requirements for an external memory interface ready-on-read (see Figure 48)

		MIN	MAX	UNIT
$t_{h(RDY)COH}$	Hold time, READY after CLKOUT high	-3		ns
$t_{su(D)RD}$	Setup time, read data before \overline{RD} strobe inactive high	8		ns
$t_{v(RDY)ARD}$	Valid time, READY after address valid on read		-2	ns
$t_{su(RDY)COH}$	Setup time, READY before CLKOUT high	22		ns

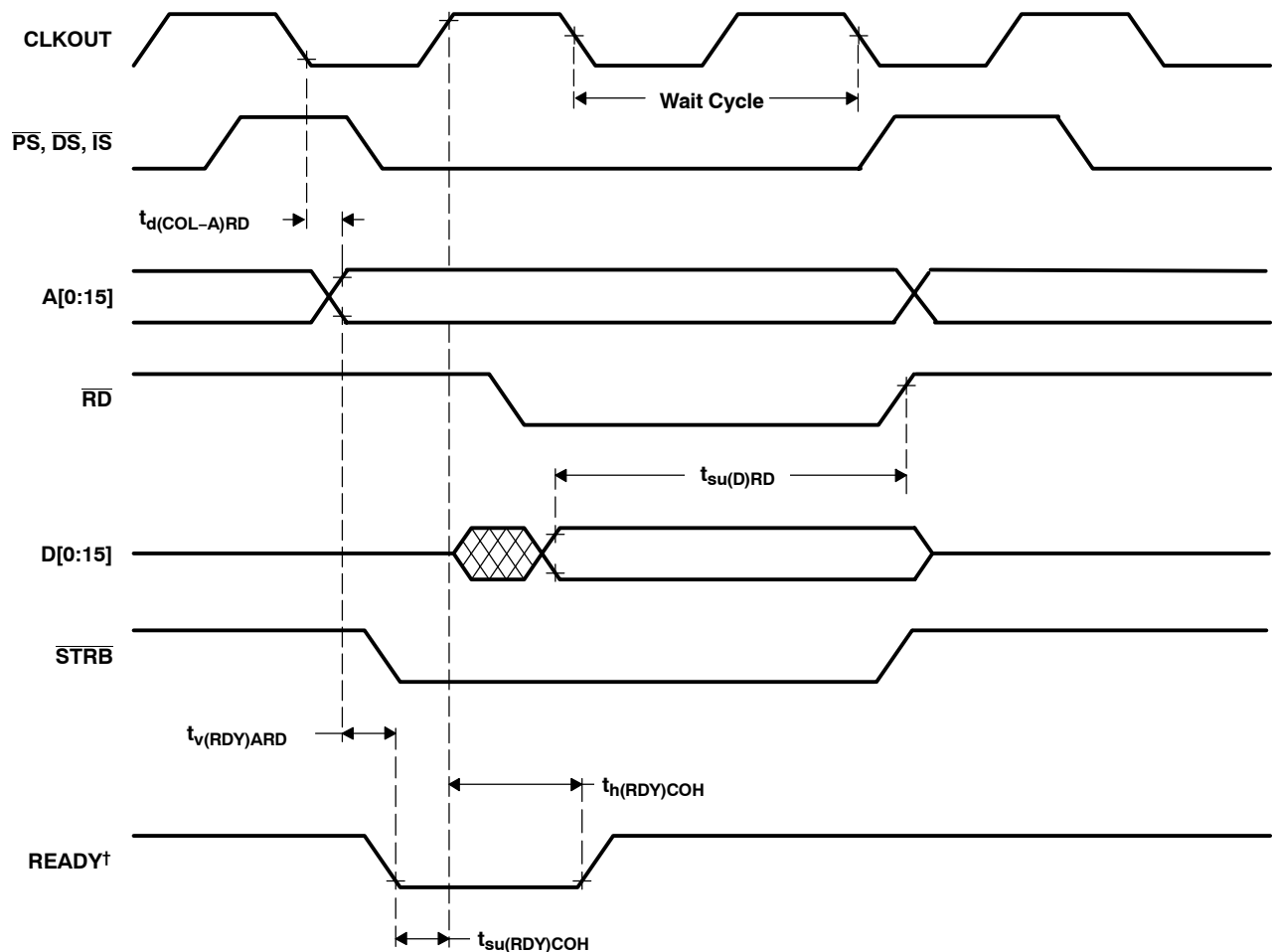

† The WSGR register must be programmed before the READY pin can be used. See the READY pin description for more details.

Figure 48. Ready-on-Read Timings

**TMS320LF2407A, TMS320LF2406A, TMS320LF2403A, TMS320LF2402A
TMS320LC2406A, TMS320LC2404A, TMS320LC2403A, TMS320LC2402A
DSP CONTROLLERS**

SPRS145L – JULY 2000 – REVISED SEPTEMBER 2007

external memory interface *ready-on-read* timing (continued)

timing requirements for an external memory interface ready-on-read with one software wait state and one external wait state (see Figure 49)

		MIN	MAX	UNIT
$t_{h(RDY)COH}$	Hold time, READY after CLKOUT high	H - 2.5		ns
$t_{su(RDY)COH}$	Setup time, READY before CLKOUT high	H - 9.5		ns
$t_{d(COL-A)RD}$	Delay time, CLKOUT low to address valid		8	ns

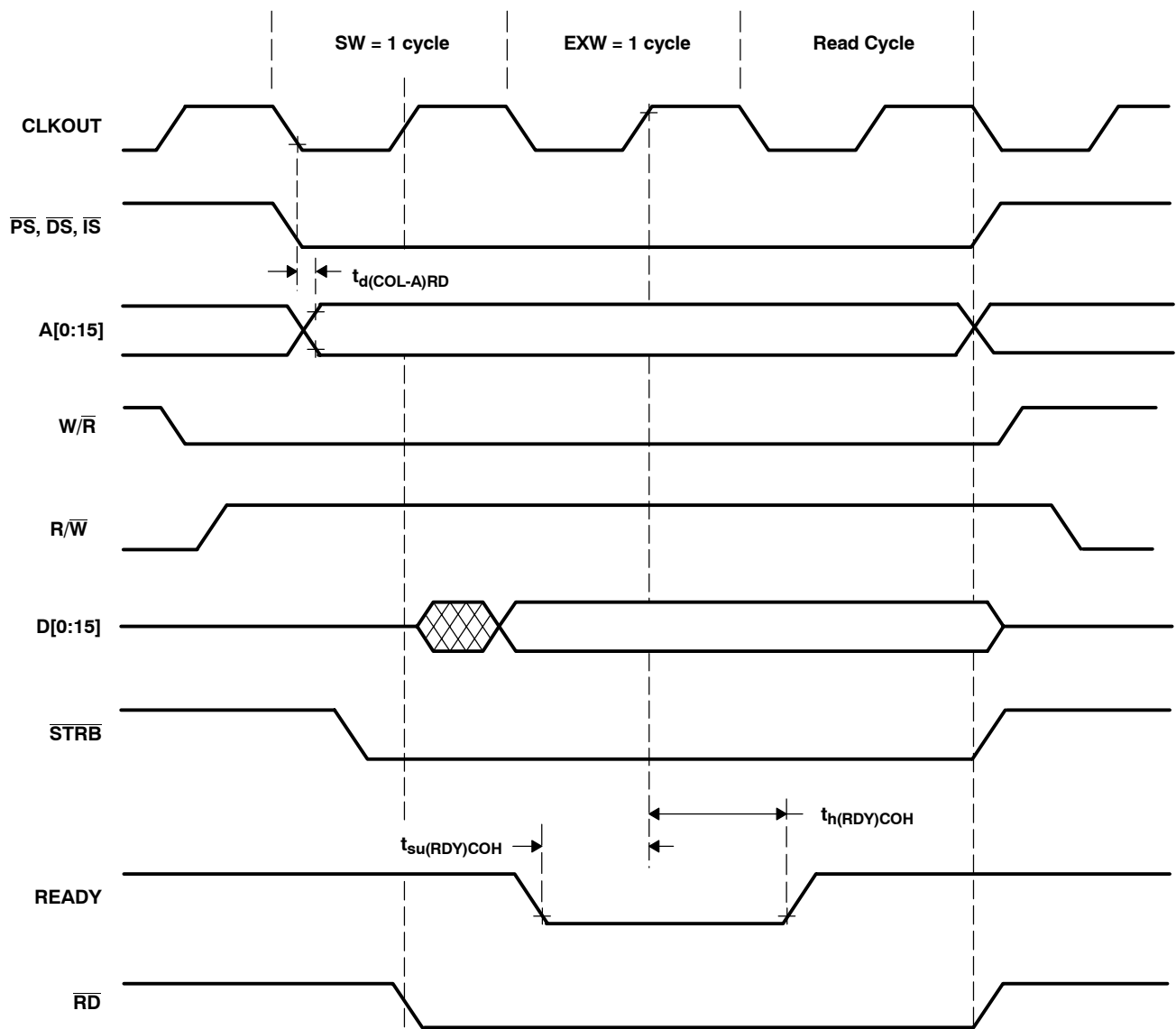

Figure 49. Ready-on-Read Timings With One Software Wait (SW) State and One External Wait (EXW) State



external memory interface *ready-on-write* timing

switching characteristics over recommended operating conditions for an external memory interface ready-on-write (see Figure 50)

PARAMETER		MIN	MAX	UNIT
$t_{d(\text{COH-A})W}$	Delay time, CLKOUT high to address valid		10	ns

timing requirements for an external memory interface ready-on-write [$H = 0.5t_{c(\text{CO})}$]
 (see Figure 50)

		MIN	MAX	UNIT
$t_{h(\text{RDY})\text{COH}}$	Hold time, READY after CLKOUT high	-3		ns
$t_{\text{su}(\text{D})W}$	Setup time, write data before $\overline{\text{WE}}$ strobe inactive high	2H-17		ns
$t_{v(\text{RDY})AW}$	Valid time, READY after address valid on write		-3	ns
$t_{\text{su}(\text{RDY})\text{COH}}$	Setup time, READY before CLKOUT high	22		ns

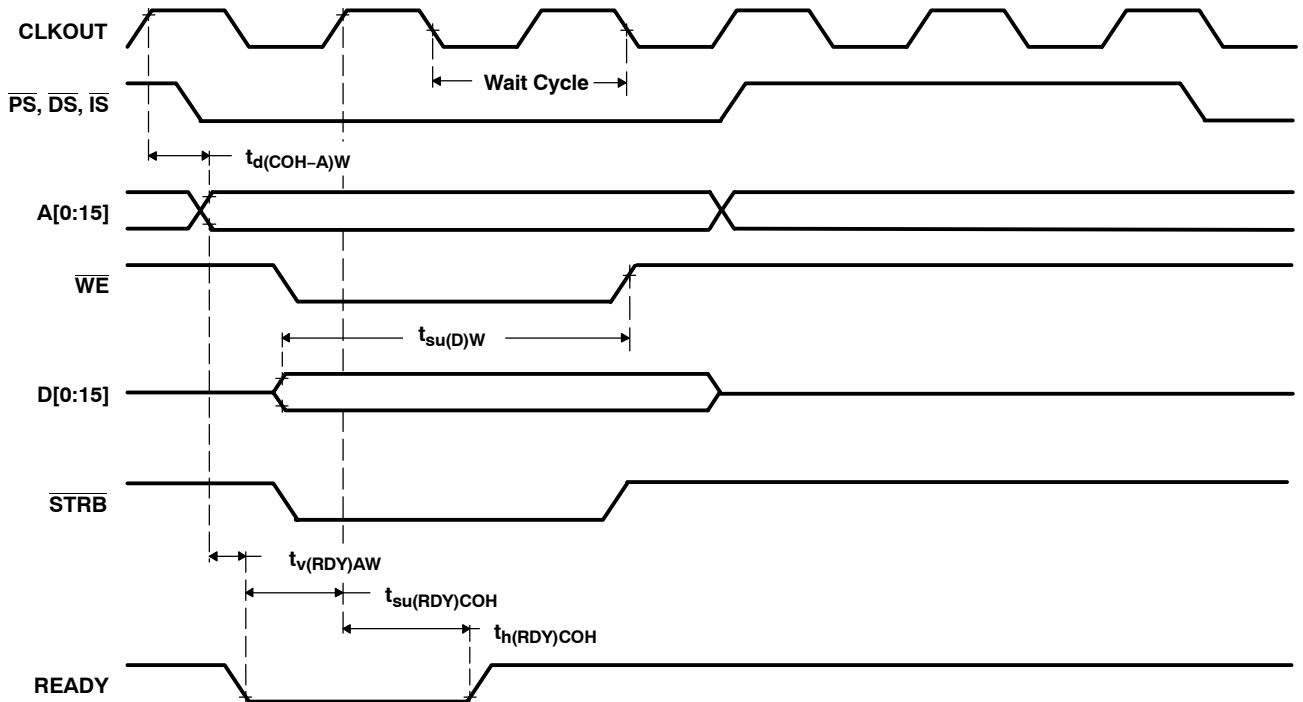

Figure 50. Ready-on-Write Timings

**TMS320LF2407A, TMS320LF2406A, TMS320LF2403A, TMS320LF2402A
TMS320LC2406A, TMS320LC2404A, TMS320LC2403A, TMS320LC2402A
DSP CONTROLLERS**

SPRS145L – JULY 2000 – REVISED SEPTEMBER 2007

external memory interface *ready-on-write* timing (continued)

timing requirements for an external memory interface ready-on-write with one software wait state and one external wait state (see Figure 51)

		MIN	MAX	UNIT
$t_{h(RDY)COH}$	Hold time, READY after CLKOUT high	H - 2.5		ns
$t_{su(RDY)COH}$	Setup time, READY before CLKOUT high	H - 9.5		ns
$t_{d(COH-A)W}$	Delay time, CLKOUT high to address valid		10	ns

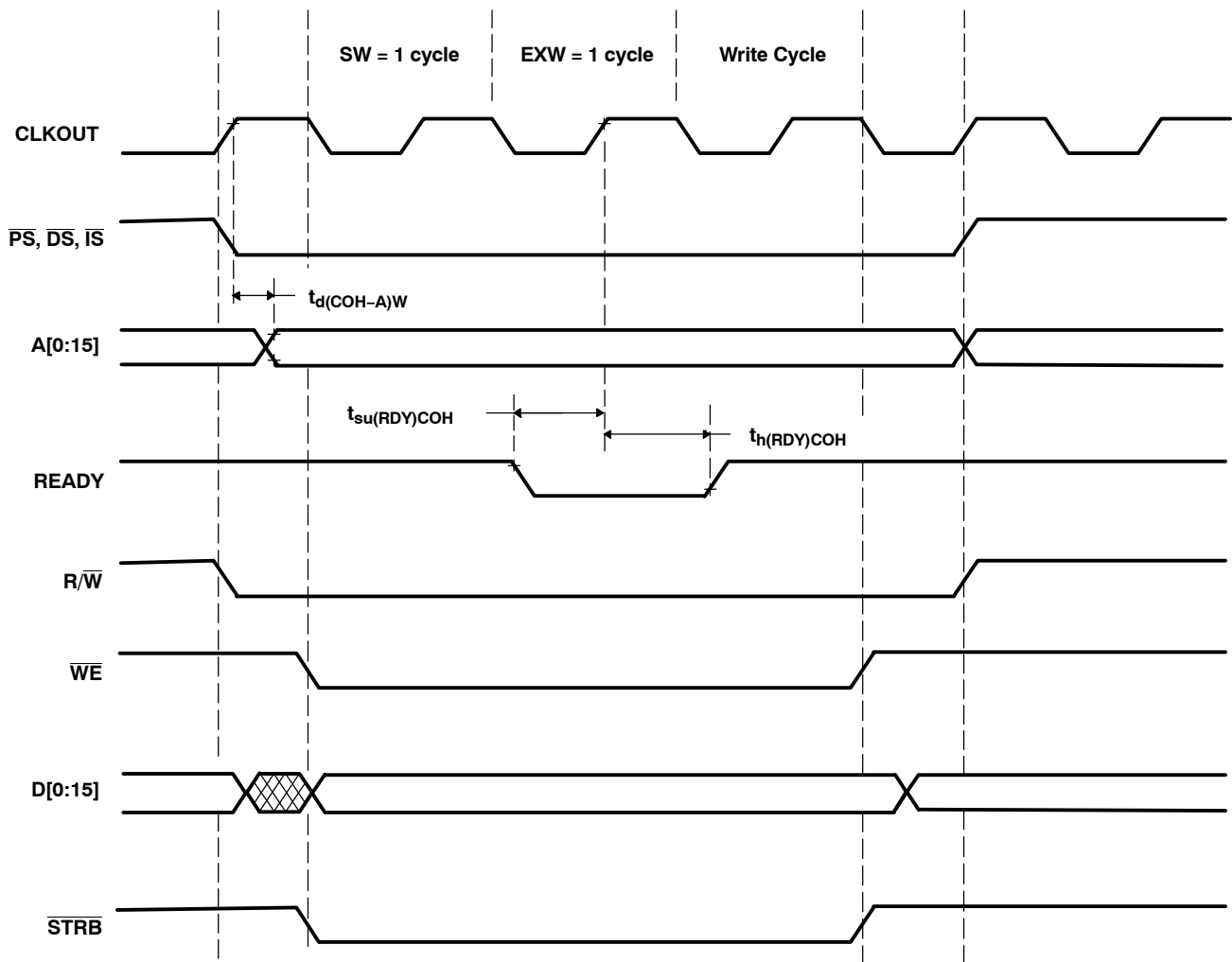

Figure 51. Ready-on-Write Timings With One Software Wait (SW) State and One External Wait (EXW) State



**TMS320LF2407A, TMS320LF2406A, TMS320LF2403A, TMS320LF2402A
TMS320LC2406A, TMS320LC2404A, TMS320LC2403A, TMS320LC2402A
DSP CONTROLLERS**

SPRS145L – JULY 2000 – REVISED SEPTEMBER 2007

10-bit analog-to-digital converter (ADC)

The 10-bit ADC has a separate power bus for its analog circuitry. These pins are referred to as V_{CCA} and V_{SSA} . The power bus isolation is to enhance ADC performance by preventing digital switching noise of the logic circuitry that can be present on V_{SS} and V_{CC} from coupling into the ADC analog stage. All ADC specifications are given with respect to V_{SSA} unless otherwise noted.

Resolution 10-bit (1024 values)
 Monotonic Assured
 Output conversion mode 000h to 3FFh (000h for $V_I \leq V_{REFLO}$; 3FFh for $V_I \geq V_{REFHI}$)
 Minimum conversion time (including sample time) 500 ns

recommended operating conditions

		MIN	NOM	MAX	UNIT
V_{CCA}	Analog supply voltage	3.0	3.3	3.6	V
V_{SSA}	Analog ground		0		V
V_{REFHI}	Analog supply reference source [†]	‡		V_{CCA}	V
V_{REFLO}	Analog ground reference source [†]		V_{SSA}		V
V_{AI}	Analog input voltage, ADCIN00–ADCIN07	V_{REFLO}		V_{REFHI}	V

[†] V_{REFHI} and V_{REFLO} must be stable, within $\pm 1/2$ LSB of the required resolution, during the entire conversion time.

[‡] V_{REFHI} can be from 2.0 V to V_{CCA} ; however, the accuracy of the ADC depends on the ground bounce and noise on the target board.

ADC operating frequency

	MIN	MAX	UNIT
ADC operating frequency	4	30	MHz



**TMS320LF2407A, TMS320LF2406A, TMS320LF2403A, TMS320LF2402A
TMS320LC2406A, TMS320LC2404A, TMS320LC2403A, TMS320LC2402A
DSP CONTROLLERS**

SPRS145L – JULY 2000 – REVISED SEPTEMBER 2007

10-bit analog-to-digital converter (ADC) (continued)

operating characteristics over recommended operating condition ranges[†]

PARAMETER		DESCRIPTION	MIN	TYP	MAX	UNIT
I _{CCA}	Analog supply current	V _{CCA} = 3.3 V		10	22	mA
		V _{CCA} = V _{REFHI} = 3.3 V	PLL or OSC power down		1	μA
I _{ADREFHI}	V _{REFHI} input current		0.75	1.5		mA
I _{ADCIN}	Analog input leakage				1	μA
C _{ai}	Analog input capacitance	Typical capacitive load on analog input pin	Non-sampling		10	pF
			Sampling		30	
t _{d(PU)}	Delay time, power-up to ADC valid	Time to stabilize analog stage after power-up			10	μs
Z _{AI}	Analog input source impedance	Analog input source impedance needed for conversions to remain within specifications at min t _{w(SH)}		53	10	Ω
	Zero-offset error			±2		LSB

[†] Absolute resolution = 3.22 mV. At V_{REFHI} = 3.3 V and V_{REFLO} = 0 V, this is one LSB. As V_{REFHI} decreases, V_{REFLO} increases, or both, the LSB size decreases. Therefore, the absolute accuracy and differential/integral linearity errors in terms of LSBs increase.

E_{DNL} and E_{INL}

PARAMETER	DESCRIPTION	CLKOUT	MIN	MAX	UNIT
E _{DNL} [‡]	Differential nonlinearity error	30 MHz		±2	LSB
E _{INL} [‡]	Integral nonlinearity error	30 MHz		±2	LSB

[‡] Test conditions: V_{REFHI} = V_{CCA}, V_{REFLO} = V_{SSA}



10-bit analog-to-digital converter (ADC) (continued)

internal ADC module timing[†] (see Figure 52)

		MIN	MAX	UNIT
$t_{c(AD)}$	Cycle time, ADC prescaled clock	33.3		ns
$t_{w(SHC)}$	Pulse duration, total sample/hold and conversion time [‡]	500		ns
$t_{d(SOC-SH)}$	Delay time, start of conversion to beginning of sample and hold	$2t_{c(CO)}$		ns
$t_{w(SH)}$	Pulse duration, sample and hold time	$2t_{c(AD)}$ [§]	$32t_{c(AD)}$	ns
$t_{w(C)}$	Pulse duration, total conversion time	$10t_{c(AD)}$		ns
$t_{d(EOC)}$	Delay time, end of conversion to data loaded into result register	$2t_{c(CO)}$		ns
$t_{d(ADCINT)}$	Delay time, ADC flag to ADC interrupt	$2t_{c(CO)}$		ns

[†] The ADC timing diagram represents a typical conversion sequence. See the ADC chapter in the *TMS320LF/LC240xA DSP Controllers Reference Guide: System and Peripherals* (literature number SPRU357) for more details.

[‡] The total sample/hold and conversion time is determined by the summation of $t_{d(SOC-SH)}$, $t_{w(SH)}$, $t_{w(C)}$, and $t_{d(EOC)}$.

[§] Can be varied by ACQ Prescaler bits in the ADCTRL1 register

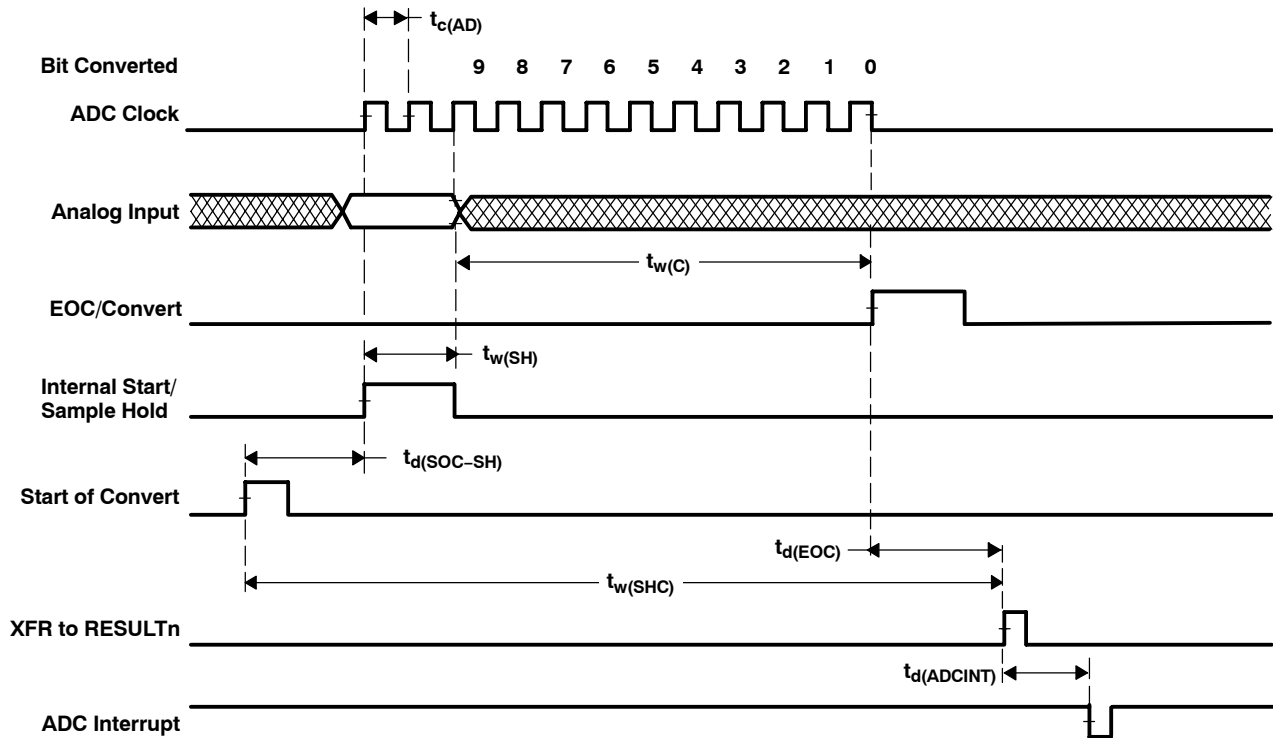

Figure 52. Analog-to-Digital Internal Module Timing

TMS320LF2407A, TMS320LF2406A, TMS320LF2403A, TMS320LF2402A TMS320LC2406A, TMS320LC2404A, TMS320LC2403A, TMS320LC2402A DSP CONTROLLERS

SPRS145L – JULY 2000 – REVISED SEPTEMBER 2007

Flash parameters @40 MHz CLOCKOUT†

PARAMETER		MIN	TYP	MAX	UNIT
Clear/Programming time‡	Time/Word (16-bit)		30		µs
	Time/4K Sector		130		ms
	Time/12K Sector		400		ms
Erase time‡	Time/4K Sector		350		ms
	Time/12K Sector		1		s
I _{CCP} (V _{CCP} pin current)	Indicates the typical/maximum current consumption during the Clear-Erase-Program (C-E-P) cycle		5	15	mA

† TI releases upgrades to the Flash algorithms for these devices; hence, these typical values are subject to change.

‡ The indicated time does not include the time it takes to load the C-E-P algorithm and the code (to be programmed) onto on-chip RAM. The values specified are when V_{DD} = 3.3 V and V_{CCP} = 5 V, and any deviation from these values could affect the timing parameters. Aging and process variance could also impact the timing parameters.

migrating from LF240xA (Flash) devices to LC240xA (ROM) devices

When migrating from a Flash to a ROM device, be sure to review this section for a list of important differences that should be considered. Customer applications should consider these differences in their design, prior to ROM code submission. Due to the fact that the flash and ROM are different silicon, the following parameters may be similar but not exactly identical. Refer to the respective datasheet sections for more detail:

- EMI/ESD behavior
- ADC performance
- Current consumption
- Device ID register values

Table 18 outlines the differences between the LF240xA (Flash) devices and the LC240xA (ROM) devices.

Table 18. Differences Between LF240xA (Flash) Devices and LC240xA (ROM) Devices

FEATURE	LF2406A	LC2406A	LC2404A	LF2403A	LC2403A	LF2402A	LC2402A
On-chip Flash or ROM (see Note 1)	32K	32K	16K	16K	16K	8K	6K
Single-Access RAM (SARAM) (16-bit words)	2K	2K	1K	512	512	512	—
Boot ROM	Yes	—	—	Yes	Yes	Yes	—
Event Managers	EVA, EVB	EVA, EVB	EVA, EVB	EVA	EVA	EVA	EVA
ADC Channels	16	16	16	8	8	8	8
SPI	Yes	Yes	Yes	Yes [§]	Yes [§]	—	—
CAN	Yes	Yes	—	Yes	Yes	—	—
GPIO Pins	41	41	41	21	21	21	21
BIÖ Pin	Yes	Yes	Yes	—	—	—	—
TDIRx Pin	Yes	Yes	Yes	—	—	—	—
External Interrupts	5	5	5	3	3	3	3
Access to External Memory Spaces [¶]	See Note 2	See Note 3	See Note 3	See Note 2	See Note 3	See Note 2	See Note 3
V _{CCP} Pin Functionality	V _{CCP}	No Connect	No Connect	V _{CCP}	No Connect	V _{CCP}	No Connect
Packaging	100-pin PZ	100-pin PZ	100-pin PZ	64-pin PAG	64-pin PAG	64-pin PG	64-pin PG, PAG

[§] The SPIÖTE pin is not available on the LF2403A. See the SPI Slave Mode Operation in LF2403A section.

[¶] Application code should **NOT** access Illegal/Reserved addresses.

- NOTES:
1. The last 64 words of ROM are reserved for TI internal testing. User code should not occupy these locations. See the device memory map for details.
 2. Access to external Program, Data, and I/O space is considered illegal and would assert an NMI.
 3. The external Program and I/O spaces are implemented as “reserved” addresses and any access will not assert an NMI. However, the external data memory space is illegal.



migrating from 240x devices to 240xA devices

This section highlights the new features/migration issues of the 240xA devices (as compared to the 240x family) and describes the impact these features/issues have on user applications.

maximum clock speed

240xA devices can operate at a maximum speed of 40 MHz compared to the 30-MHz operation of 240x devices. This change in clock speed warrants a change in the register contents of all the peripherals. For example, to maintain the same baud rate, the divisor values that are loaded to the SPI, SCI, and CAN registers must be recalculated.

code security module

240xA devices incorporate a “code security module” which protects the contents of program memory from unauthorized duplication. Passwords stored in password locations (PWL) 0040h to 0043h are used for this purpose. Even if the code is not secured with passwords (i.e., PWL contains FFFFFFFFFFFFFFFFh), the PWL must still be read to gain access to the program memory contents. Note that locations 0040h to 0043h were available for user code in the 240x devices, which lack the “code security module”. In 240xA devices, these locations are reserved for the passwords and are not available for the user code. Even if code security feature is not used, these locations must be written with all ones. This fact must be borne in mind while submitting ROM codes to TI.

input-qualifier circuitry

An input-qualifier circuitry qualifies the input signal to the CAP1–6 (QEP1–4), XINT1/2, ADCSOC, and $\overline{\text{PDPINTA/B}}$ pins in the x240xA devices. The state of the internal input signal will change only after these pins are high/low for 6 (12) clock edges. The user must hold the pin high/low for 6 (12) cycles to ensure that the device see the level change. The increase in the pulse width of the signals used to excite these pins must be taken into account while migrating from the 240x to the 240xA family.

Bit 6 of the SCSR2 register controls whether 6 clock edges (bit 6 = 0) or 12 clock edges (bit 6 = 1) are used to block 5- or 11-cycle glitches. This bit is a “reserved” bit in 240x devices.

status of the $\overline{\text{PDPINTx}}$ pin

The current status of the $\overline{\text{PDPINTx}}$ pins is now reflected in bit 8 of the COMCONx registers. This bit is a “reserved” bit in 240x devices.

operation of the IOPC0 pin

At reset, all LF240xA devices come up with the $\overline{\text{W/R}}/\text{IOPC0}$ pin in $\overline{\text{W/R}}$ mode. On devices that lack an external memory interface (e.g., LF2406A), $\overline{\text{W/R}}$ mode is not functional and MCRB.0 must be set to a 0 if the IOPC0 pin is to be used. The XMIF Hi-Z control bit (bit 4 of the SCSR2 register) is reserved in these devices and must be written with a zero.

external pulldown resistor for $\overline{\text{TRST}}$ pin

An external pulldown resistor may be needed for the $\overline{\text{TRST}}$ pin in boards that operate in noisy environments. Refer to the $\overline{\text{TRST}}$ pin description for more details.

TMS320LF2407A, TMS320LF2406A, TMS320LF2403A, TMS320LF2402A TMS320LC2406A, TMS320LC2404A, TMS320LC2403A, TMS320LC2402A DSP CONTROLLERS

SPRS145L – JULY 2000 – REVISED SEPTEMBER 2007

migrating from LF240x devices to LC240xA devices

When migrating from an “unsecured” Flash device (LF240x) to a “secured” ROM device (LC240xA), two migration paths have to be taken into consideration:

- Migrating from a 240x device to a 240xA device (see the Migrating From 240x Devices to 240xA Devices section)
- Migrating from a Flash (LF) device to a ROM (LC) device (see the Migrating From LF240xA (Flash) Devices to LC240xA (ROM) Devices section)



**TMS320LF2407A, TMS320LF2406A, TMS320LF2403A, TMS320LF2402A
TMS320LC2406A, TMS320LC2404A, TMS320LC2403A, TMS320LC2402A
DSP CONTROLLERS**

SPRS145L – JULY 2000 – REVISED SEPTEMBER 2007

peripheral register description

Table 19 is a collection of all the programmable registers of the LF240xA/LC240xA and is provided as a quick reference.

Table 19. LF240xA/LC240xA DSP Peripheral Register Description

ADDR	BIT 15	BIT 14	BIT 13	BIT 12	BIT 11	BIT 10	BIT 9	BIT 8	REG	
	BIT 7	BIT 6	BIT 5	BIT 4	BIT 3	BIT 2	BIT 1	BIT 0		
DATA MEMORY SPACE										
CPU STATUS REGISTERS										
	ARP		OV	OVM	1	INTM	DP(8)			
	DP(7)	DP(6)	DP(5)	DP(4)	DP(3)	DP(2)	DP(1)	DP(0)		
	ARB		CNF	TC	SXM	C	1			
	1	1	1	XF	1	1	PM			
GLOBAL MEMORY AND CPU INTERRUPT REGISTERS										
00004h	—	—	—	—	—	—	—	—	IMR	
	—	—	INT6 MASK	INT5 MASK	INT4 MASK	INT3 MASK	INT2 MASK	INT1 MASK		
00005h	Reserved									GREG
00006h	—	—	—	—	—	—	—	—	IFR	
	—	—	INT6 FLAG	INT5 FLAG	INT4 FLAG	INT3 FLAG	INT2 FLAG	INT1 FLAG		
SYSTEM REGISTERS										
07010h	IRQ0.15	IRQ0.14	IRQ0.13	IRQ0.12	IRQ0.11	IRQ0.10	IRQ0.9	IRQ0.8	PIRQR0	
	IRQ0.7	IRQ0.6	IRQ0.5	IRQ0.4	IRQ0.3	IRQ0.2	IRQ0.1	IRQ0.0		
07011h	IRQ1.15	IRQ1.14	IRQ1.13	IRQ1.12	IRQ1.11	IRQ1.10	IRQ1.9	IRQ1.8	PIRQR1	
	IRQ1.7	IRQ1.6	IRQ1.5	IRQ1.4	IRQ1.3	IRQ1.2	IRQ1.1	IRQ1.0		
07012h	IRQ2.15	IRQ2.14	IRQ2.13	IRQ2.12	IRQ2.11	IRQ2.10	IRQ2.9	IRQ2.8	PIRQR2	
	IRQ2.7	IRQ2.6	IRQ2.5	IRQ2.4	IRQ2.3	IRQ2.2	IRQ2.1	IRQ2.0		
07013h	Illegal									
07014h	IAK0.15	IAK0.14	IAK0.13	IAK0.12	IAK0.11	IAK0.10	IAK0.9	IAK0.8	PIACKR0	
	IAK0.7	IAK0.6	IAK0.5	IAK0.4	IAK0.3	IAK0.2	IAK0.1	IAK0.0		
07015h	IAK1.15	IAK1.14	IAK1.13	IAK1.12	IAK1.11	IAK1.10	IAK1.9	IAK1.8	PIACKR1	
	IAK1.7	IAK1.6	IAK1.5	IAK1.4	IAK1.3	IAK1.2	IAK1.1	IAK1.0		
07016h	IAK2.15	IAK2.14	IAK2.13	IAK2.12	IAK2.11	IAK2.10	IAK2.9	IAK2.8	PIACKR2	
	IAK2.7	IAK2.6	IAK2.5	IAK2.4	IAK2.3	IAK2.2	IAK2.1	IAK2.0		
07017h	Illegal									
07018h	—	CLKSRC	LPM1	LPM0	CLK PS2	CLK PS1	CLK PS0	—	SCSR1	
	ADC CLKEN	SCI CLKEN	SPI CLKEN	CAN CLKEN	EVB CLKEN	EVA CLKEN	—	ILLADR		
07019h	—	I/P QUALIFIER CLOCKS	WD OVERRIDE	XMIF HI Z	BOOT_EN	MP/MC	DON	PON	SCSR2	
0701Ah to 0701Bh	Illegal									
0701Ch	DIN15	DIN14	DIN13	DIN12	DIN11	DIN10	DIN9	DIN8	DINR	
	DIN7	DIN6	DIN5	DIN4	DIN3	DIN2	DIN1	DIN0		
0701Dh	Illegal									
0701Eh	V15	V14	V13	V12	V11	V10	V9	V8	PIVR	
	V7	V6	V5	V4	V3	V2	V1	V0		
0701Fh	Illegal									

Indicates change with respect to the F243/F241, C242 device register maps.



**TMS320LF2407A, TMS320LF2406A, TMS320LF2403A, TMS320LF2402A
TMS320LC2406A, TMS320LC2404A, TMS320LC2403A, TMS320LC2402A
DSP CONTROLLERS**

SPRS145L – JULY 2000 – REVISED SEPTEMBER 2007

peripheral register descriptions (continued)

Table 19. LF240xA/LC240xA DSP Peripheral Register Description (Continued)

ADDR	BIT 15	BIT 14	BIT 13	BIT 12	BIT 11	BIT 10	BIT 9	BIT 8	REG
	BIT 7	BIT 6	BIT 5	BIT 4	BIT 3	BIT 2	BIT 1	BIT 0	
WD CONTROL REGISTERS									
07020h to 07022h	Illegal								
07023h	D7	D6	D5	D4	D3	D2	D1	D0	WDCNTR
07024h	Illegal								
07025h	D7	D6	D5	D4	D3	D2	D1	D0	WDKEY
07026h to 07028h	Illegal								
07029h	WDFLAG	WDDIS	WDCHK2	WDCHK1	WDCHK0	WDPS2	WDPS1	WDPS0	WDCR
0702Ah to 0703Fh	Illegal								
SERIAL PERIPHERAL INTERFACE (SPI) CONFIGURATION CONTROL REGISTERS									
07040h	SPI SW RESET	CLOCK POLARITY	—	—	SPI CHAR3	SPI CHAR2	SPI CHAR1	SPI CHAR0	SPICCR
07041h	—	—	—	OVERRUN INT ENA	CLOCK PHASE	MASTER/ SLAVE	TALK	SPI INT ENA	SPICTL
07042h	RECEIVER OVERRUN FLAG	SPI INT FLAG	TX BUF FULL FLAG	—	—	—	—	—	SPISTS
07043h	Illegal								
07044h	—	SPI BIT RATE 6	SPI BIT RATE 5	SPI BIT RATE 4	SPI BIT RATE 3	SPI BIT RATE 2	SPI BIT RATE 1	SPI BIT RATE 0	SPIBRR
07045h	Illegal								
07046h	ERXB15	ERXB14	ERXB13	ERXB12	ERXB11	ERXB10	ERXB9	ERXB8	SPIRXEMU
	ERXB7	ERXB6	ERXB5	ERXB4	ERXB3	ERXB2	ERXB1	ERXB0	
07047h	RXB15	RXB14	RXB13	RXB12	RXB11	RXB10	RXB9	RXB8	SPIRXBUF
	RXB7	RXB6	RXB5	RXB4	RXB3	RXB2	RXB1	RXB0	
07048h	TXB15	TXB14	TXB13	TXB12	TXB11	TXB10	TXB9	TXB8	SPITXBUF
	TXB7	TXB6	TXB5	TXB4	TXB3	TXB2	TXB1	TXB0	
07049h	SDAT15	SDAT14	SDAT13	SDAT12	SDAT11	SDAT10	SDAT9	SDAT8	SPIDAT
	SDAT7	SDAT6	SDAT5	SDAT4	SDAT3	SDAT2	SDAT1	SDAT0	
0704Ah to 0704Eh	Illegal								
0704Fh	—	SPI PRIORITY	SPI SUSP SOFT	SPI SUSP FREE	—	—	—	—	SPIPRI

Indicates change with respect to the F243/F241, C242 device register maps.



**TMS320LF2407A, TMS320LF2406A, TMS320LF2403A, TMS320LF2402A
TMS320LC2406A, TMS320LC2404A, TMS320LC2403A, TMS320LC2402A
DSP CONTROLLERS**

SPRS145L – JULY 2000 – REVISED SEPTEMBER 2007

peripheral register descriptions (continued)

Table 19. LF240xA/LC240xA DSP Peripheral Register Description (Continued)

ADDR	BIT 15	BIT 14	BIT 13	BIT 12	BIT 11	BIT 10	BIT 9	BIT 8	REG
	BIT 7	BIT 6	BIT 5	BIT 4	BIT 3	BIT 2	BIT 1	BIT 0	
SERIAL COMMUNICATIONS INTERFACE (SCI) CONFIGURATION CONTROL REGISTERS									
07050h	STOP BITS	EVEN/ODD PARITY	PARITY ENABLE	LOOP BACK ENA	ADDR/IDLE MODE	SCI CHAR2	SCI CHAR1	SCI CHAR0	SCICCR
07051h	—	RX ERR INT ENA	SW RESET	—	TXWAKE	SLEEP	TXENA	RXENA	SCICTL1
07052h	BAUD15 (MSB)	BAUD14	BAUD13	BAUD12	BAUD11	BAUD10	BAUD9	BAUD8	SCIHBAUD
07053h	BAUD7	BAUD6	BAUD5	BAUD4	BAUD3	BAUD2	BAUD1	BAUD0 (LSB)	SCILBAUD
07054h	TXRDY	TX EMPTY	—	—	—	—	RX/BK INT ENA	TX INT ENA	SCICTL2
07055h	RX ERROR	RXRDY	BRKDT	FE	OE	PE	RXWAKE	—	SCIRXST
07056h	ERXDT7	ERXDT6	ERXDT5	ERXDT4	ERXDT3	ERXDT2	ERXDT1	ERXDT0	SCIRXEMU
07057h	RXDT7	RXDT6	RXDT5	RXDT4	RXDT3	RXDT2	RXDT1	RXDT0	SCIRXBUF
07058h	Illegal								
07059h	TXDT7	TXDT6	TXDT5	TXDT4	TXDT3	TXDT2	TXDT1	TXDT0	SCITXBUF
0705Ah to 0705Eh	Illegal								
0705Fh	—	SCITX PRIORITY	SCIRX PRIORITY	SCI SOFT	SCI FREE	—	—	—	SCIPRI
07060h to 0706Fh	Illegal								
EXTERNAL INTERRUPT CONTROL REGISTERS									
07070h	XINT1 FLAG	—	—	—	—	—	—	—	XINT1CR
	—	—	—	—	—	XINT1 POLARITY	XINT1 PRIORITY	XINT1 ENA	
07071h	XINT2 FLAG	—	—	—	—	—	—	—	XINT2CR
	—	—	—	—	—	XINT2 POLARITY	XINT2 PRIORITY	XINT2 ENA	
07072h to 0708Fh	Illegal								
DIGITAL I/O CONTROL REGISTERS									
07090h	MCRA.15	MCRA.14	MCRA.13	MCRA.12	MCRA.11	MCRA.10	MCRA.9	MCRA.8	MCRA
	MCRA.7	MCRA.6	MCRA.5	MCRA.4	MCRA.3	MCRA.2	MCRA.1	MCRA.0	
07091h	Illegal								
07092h	MCRB.15	MCRB.14	MCRB.13	MCRB.12	MCRB.11	MCRB.10	MCRB.9	MCRB.8	MCRB
	MCRB.7	MCRB.6	MCRB.5	MCRB.4	MCRB.3	MCRB.2	MCRB.1	MCRB.0	
07093h	Illegal								
07094h	MCRC.15	MCRC.14	MCRC.13	MCRC.12	MCRC.11	MCRC.10	MCRC.9	MCRC.8	MCRC
	MCRC.7	MCRC.6	MCRC.5	MCRC.4	MCRC.3	MCRC.2	MCRC.1	MCRC.0	
07095h	E7DIR	E6DIR	E5DIR	E4DIR	E3DIR	E2DIR	E1DIR	E0DIR	PEDATDIR
	IOPE7	IOPE6	IOPE5	IOPE4	IOPE3	IOPE2	IOPE1	IOPE0	

Indicates change with respect to the F243/F241, C242 device register maps.



**TMS320LF2407A, TMS320LF2406A, TMS320LF2403A, TMS320LF2402A
TMS320LC2406A, TMS320LC2404A, TMS320LC2403A, TMS320LC2402A
DSP CONTROLLERS**

SPRS145L – JULY 2000 – REVISED SEPTEMBER 2007

peripheral register descriptions (continued)

Table 19. LF240xA/LC240xA DSP Peripheral Register Description (Continued)

ADDR	BIT 15	BIT 14	BIT 13	BIT 12	BIT 11	BIT 10	BIT 9	BIT 8	REG
	BIT 7	BIT 6	BIT 5	BIT 4	BIT 3	BIT 2	BIT 1	BIT 0	
DIGITAL I/O CONTROL REGISTERS (CONTINUED)									
07096h	—	F6DIR	F5DIR	F4DIR	F3DIR	F2DIR	F1DIR	F0DIR	PFDATDIR
	—	IOPF6	IOPF5	IOPF4	IOPF3	IOPF2	IOPF1	IOPF0	
07098h	A7DIR	A6DIR	A5DIR	A4DIR	A3DIR	A2DIR	A1DIR	A0DIR	PADATDIR
	IOPA7	IOPA6	IOPA5	IOPA4	IOPA3	IOPA2	IOPA1	IOPA0	
07099h	Illegal								
0709Ah	B7DIR	B6DIR	B5DIR	B4DIR	B3DIR	B2DIR	B1DIR	B0DIR	PBDATDIR
	IOPB7	IOPB6	IOPB5	IOPB4	IOPB3	IOPB2	IOPB1	IOPB0	
0709Bh	Illegal								
0709Ch	C7DIR	C6DIR	C5DIR	C4DIR	C3DIR	C2DIR	C1DIR	C0DIR	PCDATDIR
	IOPC7	IOPC6	IOPC5	IOPC4	IOPC3	IOPC2	IOPC1	IOPC0	
0709Dh	Illegal								
0709Eh	—	—	—	—	—	—	—	D0DIR	PDDATDIR
	—	—	—	—	—	—	—	IOPD0	
0709Fh	Illegal								
ANALOG-TO-DIGITAL CONVERTER (ADC) REGISTERS									
070A0h	—	ADC S/W RESET	SOFT	FREE	ACQ PRESCALE3	ACQ PRESCALE2	ACQ PRESCALE1	ACQ PRESCALE0	ADCTRL1
	CONV PRE-SCALE (CPS)	CONTINUOUS RUN	INT PRIORITY	SEQ1/2 CASCADE	—	—	—	—	
070A1h	EVB SOC EN SEQ1	RESET SEQ1	SOC SEQ1	SEQ1 BUSY	INT ENA SEQ1 Mode1	INT ENA SEQ1 Mode0	INT FLAG SEQ1	EVA SOC EN SEQ1	ADCTRL2
	EXT SOC EN SEQ1	Reset SEQ2	SOC SEQ2	SEQ2 BUSY	INT ENA SEQ2 Mode1	INT ENA SEQ2 Mode0	INT FLAG SEQ2	EVB SOC EN SEQ2	
070A2h	—	—	—	—	—	—	—	—	MAXCONV
	—	MAXCONV2 2	MAXCONV2 1	MAXCONV2 0	MAXCONV1 3	MAXCONV1 2	MAXCONV1 1	MAXCONV1 0	
070A3h	CONV 3	CONV 3	CONV 3	CONV 3	CONV 2	CONV 2	CONV 2	CONV 2	CHSELSEQ1
	CONV 1	CONV 1	CONV 1	CONV 1	CONV 0	CONV 0	CONV 0	CONV 0	
070A4h	CONV 7	CONV 7	CONV 7	CONV 7	CONV 6	CONV 6	CONV 6	CONV 6	CHSELSEQ2
	CONV 5	CONV 5	CONV 5	CONV 5	CONV 4	CONV 4	CONV 4	CONV 4	
070A5h	CONV 11	CONV 11	CONV 11	CONV 11	CONV 10	CONV 10	CONV 10	CONV 10	CHSELSEQ3
	CONV 9	CONV 9	CONV 9	CONV 9	CONV 8	CONV 8	CONV 8	CONV 8	
070A6h	CONV 15	CONV 15	CONV 15	CONV 15	CONV 14	CONV 14	CONV 14	CONV 14	CHSELSEQ4
	CONV 13	CONV 13	CONV 13	CONV 13	CONV 12	CONV 12	CONV 12	CONV 12	
070A7h	—	—	—	—	SEQ CNTR3	SEQ CNTR2	SEQ CNTR1	SEQ CNTR0	AUTO_SEQ_SR
	SEQ2 STATE 3	SEQ2 STATE 2	SEQ2 STATE 1	SEQ2 STATE 0	SEQ1 STATE 3	SEQ1 STATE 2	SEQ1 STATE 1	SEQ1 STATE 0	
070A8h	D9	D8	D7	D6	D5	D4	D3	D2	RESULT0
	D1	D0	0	0	0	0	0	0	
070A9h	D9	D8	D7	D6	D5	D4	D3	D2	RESULT1
	D1	D0	0	0	0	0	0	0	
070AAh	D9	D8	D7	D6	D5	D4	D3	D2	RESULT2
	D1	D0	0	0	0	0	0	0	

Indicates change with respect to the F243/F241, C242 device register maps.



**TMS320LF2407A, TMS320LF2406A, TMS320LF2403A, TMS320LF2402A
TMS320LC2406A, TMS320LC2404A, TMS320LC2403A, TMS320LC2402A
DSP CONTROLLERS**

SPRS145L – JULY 2000 – REVISED SEPTEMBER 2007

peripheral register descriptions (continued)

Table 19. LF240xA/LC240xA DSP Peripheral Register Description (Continued)

ADDR	BIT 15	BIT 14	BIT 13	BIT 12	BIT 11	BIT 10	BIT 9	BIT 8	REG
	BIT 7	BIT 6	BIT 5	BIT 4	BIT 3	BIT 2	BIT 1	BIT 0	
ANALOG-TO-DIGITAL CONVERTER (ADC) REGISTERS (CONTINUED)									
070ABh	D9	D8	D7	D6	D5	D4	D3	D2	RESULT3
	D1	D0	0	0	0	0	0	0	
070ACh	D9	D8	D7	D6	D5	D4	D3	D2	RESULT4
	D1	D0	0	0	0	0	0	0	
070ADh	D9	D8	D7	D6	D5	D4	D3	D2	RESULT5
	D1	D0	0	0	0	0	0	0	
070AEh	D9	D8	D7	D6	D5	D4	D3	D2	RESULT6
	D1	D0	0	0	0	0	00	0	
070AFh	D9	D8	D7	D6	D5	D4	D3	D2	RESULT7
	D1	D0	0	0	0	0	0	0	
070B0h	D9	D8	D7	D6	D5	D4	D3	D2	RESULT8
	D1	D0	0	0	0	0	0	0	
070B1h	D9	D8	D7	D6	D5	D4	D3	D2	RESULT9
	D1	D0	0	0	0	0	0	0	
070B2h	D9	D8	D7	D6	D5	D4	D3	D2	RESULT10
	D1	D0	0	0	0	0	0	0	
070B3h	D9	D8	D7	D6	D5	D4	D3	D2	RESULT11
	D1	D0	0	0	0	0	0	0	
070B4h	D9	D8	D7	D6	D5	D4	D3	D2	RESULT12
	D1	D0	0	0	0	0	0	0	
070B5h	D9	D8	D7	D6	D5	D4	D3	D2	RESULT13
	D1	D0	0	0	0	0	0	0	
070B6h	D9	D8	D7	D6	D5	D4	D3	D2	RESULT14
	D1	D0	0	0	0	0	0	0	
070B7h	D9	D8	D7	D6	D5	D4	D3	D2	RESULT15
	D1	D0	0	0	0	0	0	0	
070B8h	Reserved								
070B9h to 070FFh	Illegal								
CONTROLLER AREA NETWORK (CAN) CONFIGURATION CONTROL REGISTERS									
07100h	—	—	—	—	—	—	—	—	MDER
	MD3	MD2	ME5	ME4	ME3	ME2	ME1	ME0	
07101h	TA5	TA4	TA3	TA2	AA5	AA4	AA3	AA2	TCR
	TRS5	TRS4	TRS3	TRS2	TRR5	TRR4	TRR3	TRR2	
07102h	RFP3	RFP2	RFP1	RFP0	RML3	RML2	RML1	RML0	RCR
	RMP3	RMP2	RMP1	RMP0	OPC3	OPC2	OPC1	OPC0	
07103h	—	—	SUSP	CCR	PDR	DBO	WUBA	CDR	MCR
	ABO	STM	—	—	—	—	MBNR1	MBNR0	
07104h	—	—	—	—	—	—	—	—	BCR2
	BRP7	BRP6	BRP5	BRP4	BRP3	BRP2	BRP1	BRP0	

Indicates change with respect to the F243/F241, C242 device register maps.



**TMS320LF2407A, TMS320LF2406A, TMS320LF2403A, TMS320LF2402A
TMS320LC2406A, TMS320LC2404A, TMS320LC2403A, TMS320LC2402A
DSP CONTROLLERS**

SPRS145L – JULY 2000 – REVISED SEPTEMBER 2007

peripheral register descriptions (continued)

Table 19. LF240xA/LC240xA DSP Peripheral Register Description (Continued)

ADDR	BIT 15	BIT 14	BIT 13	BIT 12	BIT 11	BIT 10	BIT 9	BIT 8	REG
	BIT 7	BIT 6	BIT 5	BIT 4	BIT 3	BIT 2	BIT 1	BIT 0	
CONTROLLER AREA NETWORK (CAN) CONFIGURATION CONTROL REGISTERS (CONTINUED)									
07105h	—	—	—	—	—	SBG	SJW1	SJW0	BCR1
	SAM	TSEG1-3	TSEG1-2	TSEG1-1	TSEG1-0	TSEG2-2	TSEG2-1	TSEG2-0	
07106h	—	—	—	—	—	—	—	FER	ESR
	BEF	SA1	CRCE	SER	ACKE	BO	EP	EW	
07107h	—	—	—	—	—	—	—	—	GSR
	—	—	SMA	CCE	PDA	—	RM	TM	
07108h	TEC7	TEC6	TEC5	TEC4	TEC3	TEC2	TEC1	TEC0	CEC
	REC7	REC6	REC5	REC4	REC3	REC2	REC1	REC0	
07109h	—	—	MIF5	MIF4	MIF3	MIF2	MIF1	MIF0	CAN_IFR
	—	RMLIF	AAIF	WDIF	WUIF	BOIF	EPIF	WLIF	
0710Ah	MIL	—	MIM5	MIM4	MIM3	MIM2	MIM1	MIM0	CAN_IMR
	EIL	RMLIM	AAIM	WDIM	WUIM	BOIM	EPIM	WLIM	
0710Bh	LAMI	—	—	LAM0-28	LAM0-27	LAM0-26	LAM0-25	LAM0-24	LAM0_H
	LAM0-23	LAM0-22	LAM0-21	LAM0-20	LAM0-19	LAM0-18	LAM0-17	LAM0-16	
0710Ch	LAM0-15	LAM0-14	LAM0-13	LAM0-12	LAM0-11	LAM0-10	LAM0-9	LAM0-8	LAM0_L
	LAM0-7	LAM0-6	LAM0-5	LAM0-4	LAM0-3	LAM0-2	LAM0-1	LAM0-0	
0710Dh	LAMI	—	—	LAM1-28	LAM1-27	LAM1-26	LAM1-25	LAM1-24	LAM1_H
	LAM1-23	LAM1-22	LAM1-21	LAM1-20	LAM1-19	LAM1-18	LAM1-17	LAM1-16	
0710Eh	LAM1-15	LAM1-14	LAM1-13	LAM1-12	LAM1-11	LAM1-10	LAM1-9	LAM1-8	LAM1_L
	LAM1-7	LAM1-6	LAM1-5	LAM1-4	LAM1-3	LAM1-2	LAM1-1	LAM1-0	
0710Fh to 071FFh	Illegal								
Message Object #0									
07200h	IDL-15	IDL-14	IDL-13	IDL-12	IDL-11	IDL-10	IDL-9	IDL-8	MSGID0L
	IDL-7	IDL-6	IDL-5	IDL-4	IDL-3	IDL-2	IDL-1	IDL-0	
07201h	IDE	AME	AAM	IDH-28	IDH-27	IDH-26	IDH-25	IDH-24	MSGID0H
	IDH-23	IDH-22	IDH-21	IDH-20	IDH-19	IDH-18	IDH-17	IDH-16	
07202h	—	—	—	—	—	—	—	—	MSGCTRL0
	—	—	—	RTR	DLC3	DLC2	DLC1	DLC0	
07203h	Reserved								
07204h	D15	D14	D13	D12	D11	D10	D9	D8	MBX0A
	D7	D6	D5	D4	D3	D2	D1	D0	
07205h	D15	D14	D13	D12	D11	D10	D9	D8	MBX0B
	D7	D6	D5	D4	D3	D2	D1	D0	
07206h	D15	D14	D13	D12	D11	D10	D9	D8	MBX0C
	D7	D6	D5	D4	D3	D2	D1	D0	
07207h	D15	D14	D13	D12	D11	D10	D9	D8	MBX0D
	D7	D6	D5	D4	D3	D2	D1	D0	

Indicates change with respect to the F243/F241, C242 device register maps.



**TMS320LF2407A, TMS320LF2406A, TMS320LF2403A, TMS320LF2402A
TMS320LC2406A, TMS320LC2404A, TMS320LC2403A, TMS320LC2402A
DSP CONTROLLERS**

SPRS145L – JULY 2000 – REVISED SEPTEMBER 2007

peripheral register descriptions (continued)

Table 19. LF240xA/LC240xA DSP Peripheral Register Description (Continued)

ADDR	BIT 15	BIT 14	BIT 13	BIT 12	BIT 11	BIT 10	BIT 9	BIT 8	REG
	BIT 7	BIT 6	BIT 5	BIT 4	BIT 3	BIT 2	BIT 1	BIT 0	
CONTROLLER AREA NETWORK (CAN) CONFIGURATION CONTROL REGISTERS (CONTINUED)									
Message Object #1									
07208h	IDL-15	IDL-14	IDL-13	IDL-12	IDL-11	IDL-10	IDL-9	IDL-8	MSGID1L
	IDL-7	IDL-6	IDL-5	IDL-4	IDL-3	IDL-2	IDL-1	IDL-0	
07209h	IDE	AME	AAM	IDH-28	IDH-27	IDH-26	IDH-25	IDH-24	MSGID1H
	IDH-23	IDH-22	IDH-21	IDH-20	IDH-19	IDH-18	IDH-17	IDH-16	
0720Ah	—	—	—	—	—	—	—	—	MSGCTRL1
	—	—	—	RTR	DLC3	DLC2	DLC1	DLC0	
0720Bh	Reserved								
0720Ch	D15	D14	D13	D12	D11	D10	D9	D8	MBX1A
	D7	D6	D5	D4	D3	D2	D1	D0	
0720Dh	D15	D14	D13	D12	D11	D10	D9	D8	MBX1B
	D7	D6	D5	D4	D3	D2	D1	D0	
0720Eh	D15	D14	D13	D12	D11	D10	D9	D8	MBX1C
	D7	D6	D5	D4	D3	D2	D1	D0	
0720Fh	D15	D14	D13	D12	D11	D10	D9	D8	MBX1D
	D7	D6	D5	D4	D3	D2	D1	D0	
Message Object #2									
07210h	IDL-15	IDL-14	IDL-13	IDL-12	IDL-11	IDL-10	IDL-9	IDL-8	MSGID2L
	IDL-7	IDL-6	IDL-5	IDL-4	IDL-3	IDL-2	IDL-1	IDL-0	
07211h	IDE	AME	AAM	IDH-28	IDH-27	IDH-26	IDH-25	IDH-24	MSGID2H
	IDH-23	IDH-22	IDH-21	IDH-20	IDH-19	IDH-18	IDH-17	IDH-16	
07212h	—	—	—	—	—	—	—	—	MSGCTRL2
	—	—	—	RTR	DLC3	DLC2	DLC1	DLC0	
07213h	Reserved								
07214h	D15	D14	D13	D12	D11	D10	D9	D8	MBX2A
	D7	D6	D5	D4	D3	D2	D1	D0	
07215h	D15	D14	D13	D12	D11	D10	D9	D8	MBX2B
	D7	D6	D5	D4	D3	D2	D1	D0	
07216h	D15	D14	D13	D12	D11	D10	D9	D8	MBX2C
	D7	D6	D5	D4	D3	D2	D1	D0	
07217h	D15	D14	D13	D12	D11	D10	D9	D8	MBX2D
	D7	D6	D5	D4	D3	D2	D1	D0	
Message Object #3									
07218h	IDL-15	IDL-14	IDL-13	IDL-12	IDL-11	IDL-10	IDL-9	IDL-8	MSGID3L
	IDL-7	IDL-6	IDL-5	IDL-4	IDL-3	IDL-2	IDL-1	IDL-0	
07219h	IDE	AME	AAM	IDH-28	IDH-27	IDH-26	IDH-25	IDH-24	MSGID3H
	IDH-23	IDH-22	IDH-21	IDH-20	IDH-19	IDH-18	IDH-17	IDH-16	
0721Ah	—	—	—	—	—	—	—	—	MSGCTRL3
	—	—	—	RTR	DLC3	DLC2	DLC1	DLC0	
0721Bh	Reserved								
0721Ch	D15	D14	D13	D12	D11	D10	D9	D8	MBX3A
	D7	D6	D5	D4	D3	D2	D1	D0	

Indicates change with respect to the F243/F241, C242 device register maps.



**TMS320LF2407A, TMS320LF2406A, TMS320LF2403A, TMS320LF2402A
TMS320LC2406A, TMS320LC2404A, TMS320LC2403A, TMS320LC2402A
DSP CONTROLLERS**

SPRS145L – JULY 2000 – REVISED SEPTEMBER 2007

peripheral register descriptions (continued)

Table 19. LF240xA/LC240xA DSP Peripheral Register Description (Continued)

ADDR	BIT 15	BIT 14	BIT 13	BIT 12	BIT 11	BIT 10	BIT 9	BIT 8	REG
	BIT 7	BIT 6	BIT 5	BIT 4	BIT 3	BIT 2	BIT 1	BIT 0	
CONTROLLER AREA NETWORK (CAN) CONFIGURATION CONTROL REGISTERS (CONTINUED)									
0721Dh	D15	D14	D13	D12	D11	D10	D9	D8	MBX3B
	D7	D6	D5	D4	D3	D2	D1	D0	
0721Eh	D15	D14	D13	D12	D11	D10	D9	D8	MBX3C
	D7	D6	D5	D4	D3	D2	D1	D0	
0721Fh	D15	D14	D13	D12	D11	D10	D9	D8	MBX3D
	D7	D6	D5	D4	D3	D2	D1	D0	
Message Object #4									
07220h	IDL-15	IDL-14	IDL-13	IDL-12	IDL-11	IDL-10	IDL-9	IDL-8	MSGID4L
	IDL-7	IDL-6	IDL-5	IDL-4	IDL-3	IDL-2	IDL-1	IDL-0	
07221h	IDE	AME	AAM	IDH-28	IDH-27	IDH-26	IDH-25	IDH-24	MSGID4H
	IDH-23	IDH-22	IDH-21	IDH-20	IDH-19	IDH-18	IDH-17	IDH-16	
07222h	—	—	—	—	—	—	—	—	MSGCTRL4
	—	—	—	RTR	DLC3	DLC2	DLC1	DLC0	
07223h	Reserved								
07224h	D15	D14	D13	D12	D11	D10	D9	D8	MBX4A
	D7	D6	D5	D4	D3	D2	D1	D0	
07225h	D15	D14	D13	D12	D11	D10	D9	D8	MBX4B
	D7	D6	D5	D4	D3	D2	D1	D0	
07226h	D15	D14	D13	D12	D11	D10	D9	D8	MBX4C
	D7	D6	D5	D4	D3	D2	D1	D0	
07227h	D15	D14	D13	D12	D11	D10	D9	D8	MBX4D
	D7	D6	D5	D4	D3	D2	D1	D0	
Message Object #5									
07228h	IDL-15	IDL-14	IDL-13	IDL-12	IDL-11	IDL-10	IDL-9	IDL-8	MSGID5L
	IDL-7	IDL-6	IDL-5	IDL-4	IDL-3	IDL-2	IDL-1	IDL-0	
07229h	IDE	AME	AAM	IDH-28	IDH-27	IDH-26	IDH-25	IDH-24	MSGID5H
	IDH-23	IDH-22	IDH-21	IDH-20	IDH-19	IDH-18	IDH-17	IDH-16	
0722Ah	—	—	—	—	—	—	—	—	MSGCTRL5
	—	—	—	RTR	DLC3	DLC2	DLC1	DLC0	
0722Bh	Reserved								
0722Ch	D15	D14	D13	D12	D11	D10	D9	D8	MBX5A
	D7	D6	D5	D4	D3	D2	D1	D0	
0722Dh	D15	D14	D13	D12	D11	D10	D9	D8	MBX5B
	D7	D6	D5	D4	D3	D2	D1	D0	
0722Eh	D15	D14	D13	D12	D11	D10	D9	D8	MBX5C
	D7	D6	D5	D4	D3	D2	D1	D0	
0722Fh	D15	D14	D13	D12	D11	D10	D9	D8	MBX5D
	D7	D6	D5	D4	D3	D2	D1	D0	
07230h to 073FFh	Illegal								

Indicates change with respect to the F243/F241, C242 device register maps.



**TMS320LF2407A, TMS320LF2406A, TMS320LF2403A, TMS320LF2402A
TMS320LC2406A, TMS320LC2404A, TMS320LC2403A, TMS320LC2402A
DSP CONTROLLERS**

SPRS145L – JULY 2000 – REVISED SEPTEMBER 2007

peripheral register descriptions (continued)

Table 19. LF240xA/LC240xA DSP Peripheral Register Description (Continued)

ADDR	BIT 15	BIT 14	BIT 13	BIT 12	BIT 11	BIT 10	BIT 9	BIT 8	REG
	BIT 7	BIT 6	BIT 5	BIT 4	BIT 3	BIT 2	BIT 1	BIT 0	
GENERAL-PURPOSE (GP) TIMER CONFIGURATION CONTROL REGISTERS – EVA									
07400h	—	T2STAT	T1STAT	—	—	T2TOADC	—	T1TOADC(1)	GPTCONA
	T1TOADC(0)	TCOMPOE	—	—	T2PIN	—	T1PIN	—	
07401h	D15	D14	D13	D12	D11	D10	D9	D8	T1CNT
	D7	D6	D5	D4	D3	D2	D1	D0	
07402h	D15	D14	D13	D12	D11	D10	D9	D8	T1CMPR
	D7	D6	D5	D4	D3	D2	D1	D0	
07403h	D15	D14	D13	D12	D11	D10	D9	D8	T1PR
	D7	D6	D5	D4	D3	D2	D1	D0	
07404h	FREE	SOFT	—	TMODE1	TMODE0	TPS2	TPS1	TPS0	T1CON
	—	TENABLE	TCLKS1	TCLKS0	TCLD1	TCLD0	TECMPR	—	
07405h	D15	D14	D13	D12	D11	D10	D9	D8	T2CNT
	D7	D6	D5	D4	D3	D2	D1	D0	
07406h	D15	D14	D13	D12	D11	D10	D9	D8	T2CMPR
	D7	D6	D5	D4	D3	D2	D1	D0	
07407h	D15	D14	D13	D12	D11	D10	D9	D8	T2PR
	D7	D6	D5	D4	D3	D2	D1	D0	
07408h	FREE	SOFT	—	TMODE1	TMODE0	TPS2	TPS1	TPS0	T2CON
	T2SWT1	TENABLE	TCLKS1	TCLKS0	TCLD1	TCLD0	TECMPR	SELT1PR	
07409h to 07410h	Illegal								
FULL AND SIMPLE COMPARE UNIT REGISTERS – EVA									
07411h	CENABLE	CLD1	CLD0	SVENABLE	ACTRLD1	ACTRLD0	FCOMPOE	PDPINTA STATUS	COMCONA
	—	—	—	—	—	—	—	—	
07412h	Illegal								
07413h	SVRDIR	D2	D1	D0	CMP6ACT1	CMP6ACT0	CMP5ACT1	CMP5ACT0	ACTRA
	CMP4ACT1	CMP4ACT0	CMP3ACT1	CMP3ACT0	CMP2ACT1	CMP2ACT0	CMP1ACT1	CMP1ACT0	
07414h	Illegal								
07415h	—	—	—	—	DBT3	DBT2	DBT1	DBT0	DBTCONA
	EDBT3	EDBT2	EDBT1	DBTPS2	DBTPS1	DBTPS0	—	—	
07416h	Illegal								
07417h	D15	D14	D13	D12	D11	D10	D9	D8	CMPR1
	D7	D6	D5	D4	D3	D2	D1	D0	
07418h	D15	D14	D13	D12	D11	D10	D9	D8	CMPR2
	D7	D6	D5	D4	D3	D2	D1	D0	
07419h	D15	D14	D13	D12	D11	D10	D9	D8	CMPR3
	D7	D6	D5	D4	D3	D2	D1	D0	
0741Ah to 0741Fh	Illegal								

Indicates change with respect to the F243/F241, C242 device register maps.



**TMS320LF2407A, TMS320LF2406A, TMS320LF2403A, TMS320LF2402A
TMS320LC2406A, TMS320LC2404A, TMS320LC2403A, TMS320LC2402A
DSP CONTROLLERS**

SPRS145L – JULY 2000 – REVISED SEPTEMBER 2007

peripheral register descriptions (continued)

Table 19. LF240xA/LC240xA DSP Peripheral Register Description (Continued)

ADDR	BIT 15	BIT 14	BIT 13	BIT 12	BIT 11	BIT 10	BIT 9	BIT 8	REG
	BIT 7	BIT 6	BIT 5	BIT 4	BIT 3	BIT 2	BIT 1	BIT 0	
CAPTURE UNIT REGISTERS – EVA									
07420h	CAPRES	CAPQEPN		CAP3EN	—	CAP3TSEL	CAP12TSEL	CAP3TOADC	CAPCONA
	CAP1EDGE		CAP2EDGE		CAP3EDGE		—		
07421h	Illegal								
07422h	—	CAP3FIFO			CAP2FIFO		CAP1FIFO		CAPFIFOA
	—	—	—	—	—	—	—	—	
07423h	D15	D14	D13	D12	D11	D10	D9	D8	CAP1FIFO
	D7	D6	D5	D4	D3	D2	D1	D0	
07424h	D15	D14	D13	D12	D11	D10	D9	D8	CAP2FIFO
	D7	D6	D5	D4	D3	D2	D1	D0	
07425h	D15	D14	D13	D12	D11	D10	D9	D8	CAP3FIFO
	D7	D6	D5	D4	D3	D2	D1	D0	
07426h	Illegal								
07427h	D15	D14	D13	D12	D11	D10	D9	D8	CAP1FBOT
	D7	D6	D5	D4	D3	D2	D1	D0	
07428h	D15	D14	D13	D12	D11	D10	D9	D8	CAP2FBOT
	D7	D6	D5	D4	D3	D2	D1	D0	
07429h	D15	D14	D13	D12	D11	D10	D9	D8	CAP3FBOT
	D7	D6	D5	D4	D3	D2	D1	D0	
0742Ah to 0742Bh	Illegal								
EVENT MANAGER (EVA) INTERRUPT CONTROL REGISTERS									
0742Ch	—	—	—	—	—	T1OFINT ENA	T1UFINT ENA	T1CINT ENA	EVAIMRA
	T1PINT ENA	—	—	—	CMP3INT ENA	CMP2INT ENA	CMP1INT ENA	PDPINTA ENA	
0742Dh	—	—	—	—	—	—	—	—	EVAIMRB
	—	—	—	—	T2OFINT ENA	T2UFINT ENA	T2CINT ENA	T2PINT ENA	
0742Eh	—	—	—	—	—	—	—	—	EVAIMRC
	—	—	—	—	—	CAP3INT ENA	CAP2INT ENA	CAP1INT ENA	
0742Fh	—	—	—	—	—	—	—	—	EVAIFRA
	T1PINT FLAG	—	—	—	CMP3INT FLAG	CMP2INT FLAG	CMP1INT FLAG	PDPINTA FLAG	
07430h	—	—	—	—	—	—	—	—	EVAIFRB
	—	—	—	—	T2OFINT FLAG	T2UFINT FLAG	T2CINT FLAG	T2PINT FLAG	
07431h	—	—	—	—	—	—	—	—	EVAIFRC
	—	—	—	—	—	CAP3INT FLAG	CAP2INT FLAG	CAP1INT FLAG	
07432h to 074FFh	Illegal								

Indicates change with respect to the F243/F241, C242 device register maps.



**TMS320LF2407A, TMS320LF2406A, TMS320LF2403A, TMS320LF2402A
TMS320LC2406A, TMS320LC2404A, TMS320LC2403A, TMS320LC2402A
DSP CONTROLLERS**

SPRS145L – JULY 2000 – REVISED SEPTEMBER 2007

peripheral register descriptions (continued)

Table 19. LF240xA/LC240xA DSP Peripheral Register Description (Continued)

ADDR	BIT 15	BIT 14	BIT 13	BIT 12	BIT 11	BIT 10	BIT 9	BIT 8	REG
	BIT 7	BIT 6	BIT 5	BIT 4	BIT 3	BIT 2	BIT 1	BIT 0	
GENERAL-PURPOSE (GP) TIMER CONFIGURATION CONTROL REGISTERS – EVB									
07500h	—	T4STAT	T3STAT	—	—	T4TOADC	—	T3TOADC(1)	GPTCONB
	T3TOADC(0)	TCOMPOEB	—	—	T4PIN	—	T3PIN	—	
07501h	D15	D14	D13	D12	D11	D10	D9	D8	T3CNT
	D7	D6	D5	D4	D3	D2	D1	D0	
07502h	D15	D14	D13	D12	D11	D10	D9	D8	T3CMPR
	D7	D6	D5	D4	D3	D2	D1	D0	
07503h	D15	D14	D13	D12	D11	D10	D9	D8	T3PR
	D7	D6	D5	D4	D3	D2	D1	D0	
07504h	FREE	SOFT	—	TMODE1	TMODE0	TPS2	TPS1	TPS0	T3CON
	—	TENABLE	TCLKS1	TCLKS0	TCLD1	TCLD0	TECMPR	—	
07505h	D15	D14	D13	D12	D11	D10	D9	D8	T4CNT
	D7	D6	D5	D4	D3	D2	D1	D0	
07506h	D15	D14	D13	D12	D11	D10	D9	D8	T4CMPR
	D7	D6	D5	D4	D3	D2	D1	D0	
07507h	D15	D14	D13	D12	D11	D10	D9	D8	T4PR
	D7	D6	D5	D4	D3	D2	D1	D0	
07508h	FREE	SOFT	—	TMODE1	TMODE0	TPS2	TPS1	TPS0	T4CON
	T4SWT3	TENABLE	TCLKS1	TCLKS0	TCLD1	TCLD0	TECMPR	SELT3PR	
07509h to 07510h	Reserved								
FULL AND SIMPLE COMPARE UNIT REGISTERS– EVB									
07511h	CENABLE	CLD1	CLD0	SVENABLE	ACTRLD1	ACTRLD0	FCOMPOEB	PDPINTB STATUS	COMCONB
	—	—	—	—	—	—	—	—	
07512h	Reserved								
07513h	SVRDIR	D2	D1	D0	CMP12ACT1	CMP12ACT0	CMP11ACT1	CMP11ACT0	ACTRB
	CMP10ACT1	CMP10ACT0	CMP9ACT1	CMP9ACT0	CMP8ACT1	CMP8ACT0	CMP7ACT1	CMP7ACT0	
07514h	Reserved								
07515h	—	—	—	—	DBT3	DBT2	DBT1	DBT0	DBTCONB
	EDBT3	EDBT2	EDBT1	DBTPS2	DBTPS1	DBTPS0	—	—	
07516h	Reserved								
07517h	D15	D14	D13	D12	D11	D10	D9	D8	CMPR4
	D7	D6	D5	D4	D3	D2	D1	D0	
07518h	D15	D14	D13	D12	D11	D10	D9	D8	CMPR5
	D7	D6	D5	D4	D3	D2	D1	D0	
07519h	D15	D14	D13	D12	D11	D10	D9	D8	CMPR6
	D7	D6	D5	D4	D3	D2	D1	D0	
0751Ah to 0751Fh	Reserved								

 Indicates change with respect to the F243/F241, C242 device register maps.



**TMS320LF2407A, TMS320LF2406A, TMS320LF2403A, TMS320LF2402A
TMS320LC2406A, TMS320LC2404A, TMS320LC2403A, TMS320LC2402A
DSP CONTROLLERS**

SPRS145L – JULY 2000 – REVISED SEPTEMBER 2007

peripheral register descriptions (continued)

Table 19. LF240xA/LC240xA DSP Peripheral Register Description (Continued)

ADDR	BIT 15	BIT 14	BIT 13	BIT 12	BIT 11	BIT 10	BIT 9	BIT 8	REG
	BIT 7	BIT 6	BIT 5	BIT 4	BIT 3	BIT 2	BIT 1	BIT 0	
CAPTURE UNIT REGISTERS- EVB									
07520h	CAPRES	CAPQEPN		CAP6EN	—	CAP6TSEL	CAP45SEL	CAP6TOADC	CAPCONB
	CAP4EDGE		CAP5EDGE		CAP6EDGE		—		
07521h	Reserved								
07522h	—		CAP6FIFO		CAP5FIFO		CAP4FIFO		CAPFIFOB
	—	—	—	—	—	—	—	—	
07523h	D15	D14	D13	D12	D11	D10	D9	D8	CAP4FIFO
	D7	D6	D5	D4	D3	D2	D1	D0	
07524h	D15	D14	D13	D12	D11	D10	D9	D8	CAP5FIFO
	D7	D6	D5	D4	D3	D2	D1	D0	
07525h	D15	D14	D13	D12	D11	D10	D9	D8	CAP6FIFO
	D7	D6	D5	D4	D3	D2	D1	D0	
07526h	Reserved								
07527h	D15	D14	D13	D12	D11	D10	D9	D8	CAP4FBOT
	D7	D6	D5	D4	D3	D2	D1	D0	
07528h	D15	D14	D13	D12	D11	D10	D9	D8	CAP5FBOT
	D7	D6	D5	D4	D3	D2	D1	D0	
07529h	D15	D14	D13	D12	D11	D10	D9	D8	CAP6FBOT
	D7	D6	D5	D4	D3	D2	D1	D0	
0752Ah to 0752Bh	Reserved								
EVENT MANAGER (EVB) INTERRUPT CONTROL REGISTERS									
0752Ch	—	—	—	—	—	T3OFINT ENA	T3UFINT ENA	T3CINT ENA	EVBIMRA
	T3PINT ENA	—	—	—	CMP6INT ENA	CMP5INT ENA	CMP4INT ENA	PDPINTB ENA	
0752Dh	—	—	—	—	—	—	—	—	EVBIMRB
	—	—	—	—	T4OFINT ENA	T4UFINT ENA	T4CINT ENA	T4PINT ENA	
0752Eh	—	—	—	—	—	—	—	—	EVBIMRC
	—	—	—	—	—	CAP6INT ENA	CAP5INT ENA	CAP4INT ENA	
0752Fh	—	—	—	—	—	—	—	—	EVBIFRA
	T3PINT FLAG	—	—	—	CMP6INT FLAG	CMP5INT FLAG	CMP4INT FLAG	PDPINTB FLAG	
07530h	—	—	—	—	—	—	—	—	EVBIFRB
	—	—	—	—	T4OFINT FLAG	T4UFINT FLAG	T4CINT FLAG	T4PINT FLAG	
07531h	—	—	—	—	—	—	—	—	EVBIFRC
	—	—	—	—	—	CAP6INT FLAG	CAP5INT FLAG	CAP4INT FLAG	
07532h to 0753Fh	Reserved								

Indicates change with respect to the F243/F241, C242 device register maps.



**TMS320LF2407A, TMS320LF2406A, TMS320LF2403A, TMS320LF2402A
TMS320LC2406A, TMS320LC2404A, TMS320LC2403A, TMS320LC2402A
DSP CONTROLLERS**

SPRS145L – JULY 2000 – REVISED SEPTEMBER 2007

peripheral register descriptions (continued)

Table 19. LF240xA/LC240xA DSP Peripheral Register Description (Continued)

ADDR	BIT 15	BIT 14	BIT 13	BIT 12	BIT 11	BIT 10	BIT 9	BIT 8	REG
	BIT 7	BIT 6	BIT 5	BIT 4	BIT 3	BIT 2	BIT 1	BIT 0	
KEY REGISTERS									
077F0h	High Word of the 64-Bit KEY Register								KEY3
077F1h	Third Word of the 64-Bit KEY Register								KEY2
077F2h	Second Word of the 64-Bit KEY Register								KEY1
077F3h	Low Word of the 64-Bit KEY Register								KEY0
PROGRAM MEMORY SPACE – FLASH REGISTERS									
0xx00h	—	—	—	—	—	—	—	—	PMP
	—	—	—	—	PWR DWN	KEY1	KEY0	EXEC	
0xx01h	—	—	—	—	—	—	WSVER EN	PRECND Mode1	CTRL†
	PRECND Mode0	ENG/R Mode2	ENG/R Mode1	ENG/R Mode0	FCM3	FCM2	FCM1	FCM0	
0xx02h									WADDR
0xx03h									WDATA
0xx04h	—	—	—	—	—	—	—	—	TCR
0xx05h	—	—	—	—	—	—	—	—	ENAB
0xx06h	—	—	—	—	—	—	—	—	SECT
	—	—	—	—	SECT 4 ENABLE	SECT 3 ENABLE	SECT 2 ENABLE	SECT 1 ENABLE	
I/O MEMORY SPACE									
0FF0Fh	—	—	—	—	—	—	—	—	FCMR
	—	—	—	—	—	—	—	—	
WAIT-STATE GENERATOR CONTROL REGISTER									
0FFFFh	—	—	—	—	—	BVIS.1	BVIS.0	ISWS.2	WSGR
	ISWS.1	ISWS.0	DSWS.2	DSWS.1	DSWS.0	PSWS.2	PSWS.1	PSWS.0	

Indicates change with respect to the F243/F241, C242 device register maps.

† Register shown with bits set in **register mode**.



**TMS320LF2407A, TMS320LF2406A, TMS320LF2403A, TMS320LF2402A
TMS320LC2406A, TMS320LC2404A, TMS320LC2403A, TMS320LC2402A
DSP CONTROLLERS**

SPRS145L – JULY 2000 – REVISED SEPTEMBER 2007

MECHANICAL DATA

Table 20 through Table 23 provide the typical thermal resistance characteristics for each mechanical package.

Table 20. Typical Thermal Resistance Characteristics for the PAG Package

PARAMETER	DESCRIPTION	°C/W
Θ_{JA}	Junction-to-ambient	42
Θ_{JC}	Junction-to-case	7
Ψ_{jt}	Junction-to-top of package	0.5

Table 21. Typical Thermal Resistance Characteristics for the PG Package

PARAMETER	DESCRIPTION	°C/W
Θ_{JA}	Junction-to-ambient	35
Θ_{JC}	Junction-to-case	11
Ψ_{jt}	Junction-to-top of package	1.0

Table 22. Typical Thermal Resistance Characteristics for the PGE Package

PARAMETER	DESCRIPTION	°C/W
Θ_{JA}	Junction-to-ambient	32
Θ_{JC}	Junction-to-case	8
Ψ_{jt}	Junction-to-top of package	0.5

Table 23. Typical Thermal Resistance Characteristics for the PZ Package

PARAMETER	DESCRIPTION	°C/W
Θ_{JA}	Junction-to-ambient	42
Θ_{JC}	Junction-to-case	8
Ψ_{jt}	Junction-to-top of package	0.5



MECHANICAL DATA (CONTINUED)

The following mechanical package diagram(s) reflect the most current released mechanical data available for the designated device(s).

PACKAGING INFORMATION

Orderable Device	Status ⁽¹⁾	Package Type	Package Drawing	Pins	Package Qty	Eco Plan ⁽²⁾	Lead/ Ball Finish	MSL Peak Temp ⁽³⁾	Samples (Requires Login)
TMS320LC2402APAGA	ACTIVE	TQFP	PAG	64		TBD	Call TI	Call TI	
TMS320LC2402APAGS	ACTIVE	TQFP	PAG	64		TBD	Call TI	Call TI	
TMS320LC2402APGA	ACTIVE	QFP	PG	64		TBD	Call TI	Call TI	
TMS320LC2402APGS	ACTIVE	QFP	PG	64		TBD	Call TI	Call TI	
TMS320LC2403APAGA	ACTIVE	TQFP	PAG	64		TBD	Call TI	Call TI	
TMS320LC2403APAGS	ACTIVE	TQFP	PAG	64		TBD	Call TI	Call TI	
TMS320LC2404APZA	ACTIVE	LQFP	PZ	100		TBD	Call TI	Call TI	
TMS320LC2404APZS	ACTIVE	LQFP	PZ	100		TBD	Call TI	Call TI	
TMS320LC2406APZA	ACTIVE	LQFP	PZ	100		TBD	Call TI	Call TI	
TMS320LC2406APZS	ACTIVE	LQFP	PZ	100		TBD	Call TI	Call TI	
TMS320LF2402APGA	NRND	QFP	PG	64	66	Green (RoHS & no Sb/Br)	CU NIPDAU	Level-4-260C-72 HR	
TMS320LF2402APGAR	NRND	QFP	PG	64	400	Green (RoHS & no Sb/Br)	CU NIPDAU	Level-4-260C-72 HR	
TMS320LF2402APGS	NRND	QFP	PG	64	66	Green (RoHS & no Sb/Br)	CU NIPDAU	Level-4-260C-72 HR	
TMS320LF2403APAGA	NRND	TQFP	PAG	64	160	Green (RoHS & no Sb/Br)	CU NIPDAU	Level-3-260C-168 HR	
TMS320LF2403APAGS	NRND	TQFP	PAG	64	160	Green (RoHS & no Sb/Br)	CU NIPDAU	Level-3-260C-168 HR	
TMS320LF2406APZA	NRND	LQFP	PZ	100	90	Green (RoHS & no Sb/Br)	CU NIPDAU	Level-2-260C-1 YEAR	
TMS320LF2406APZAR	NRND	LQFP	PZ	100	1000	Green (RoHS & no Sb/Br)	CU NIPDAU	Level-2-260C-1 YEAR	
TMS320LF2406APZS	NRND	LQFP	PZ	100	1	Green (RoHS & no Sb/Br)	CU NIPDAU	Level-2-260C-1 YEAR	
TMS320LF2407APGEA	NRND	LQFP	PGE	144	60	Green (RoHS & no Sb/Br)	CU NIPDAU	Level-1-260C-UNLIM	
TMS320LF2407APGES	NRND	LQFP	PGE	144	1	Green (RoHS & no Sb/Br)	CU NIPDAU	Level-1-260C-UNLIM	
TMX320LF2406APZAR	OBSOLETE	LQFP	PZ	100		TBD	Call TI	Call TI	

⁽¹⁾ The marketing status values are defined as follows:

ACTIVE: Product device recommended for new designs.

LIFEBUY: TI has announced that the device will be discontinued, and a lifetime-buy period is in effect.

NRND: Not recommended for new designs. Device is in production to support existing customers, but TI does not recommend using this part in a new design.

PREVIEW: Device has been announced but is not in production. Samples may or may not be available.

OBSOLETE: TI has discontinued the production of the device.

⁽²⁾ Eco Plan - The planned eco-friendly classification: Pb-Free (RoHS), Pb-Free (RoHS Exempt), or Green (RoHS & no Sb/Br) - please check <http://www.ti.com/productcontent> for the latest availability information and additional product content details.

TBD: The Pb-Free/Green conversion plan has not been defined.

Pb-Free (RoHS): TI's terms "Lead-Free" or "Pb-Free" mean semiconductor products that are compatible with the current RoHS requirements for all 6 substances, including the requirement that lead not exceed 0.1% by weight in homogeneous materials. Where designed to be soldered at high temperatures, TI Pb-Free products are suitable for use in specified lead-free processes.

Pb-Free (RoHS Exempt): This component has a RoHS exemption for either 1) lead-based flip-chip solder bumps used between the die and package, or 2) lead-based die adhesive used between the die and leadframe. The component is otherwise considered Pb-Free (RoHS compatible) as defined above.

Green (RoHS & no Sb/Br): TI defines "Green" to mean Pb-Free (RoHS compatible), and free of Bromine (Br) and Antimony (Sb) based flame retardants (Br or Sb do not exceed 0.1% by weight in homogeneous material)

⁽³⁾ MSL, Peak Temp. -- The Moisture Sensitivity Level rating according to the JEDEC industry standard classifications, and peak solder temperature.

Important Information and Disclaimer: The information provided on this page represents TI's knowledge and belief as of the date that it is provided. TI bases its knowledge and belief on information provided by third parties, and makes no representation or warranty as to the accuracy of such information. Efforts are underway to better integrate information from third parties. TI has taken and continues to take reasonable steps to provide representative and accurate information but may not have conducted destructive testing or chemical analysis on incoming materials and chemicals. TI and TI suppliers consider certain information to be proprietary, and thus CAS numbers and other limited information may not be available for release.

In no event shall TI's liability arising out of such information exceed the total purchase price of the TI part(s) at issue in this document sold by TI to Customer on an annual basis.

PG (R-PQFP-G64)

PLASTIC QUAD FLATPACK

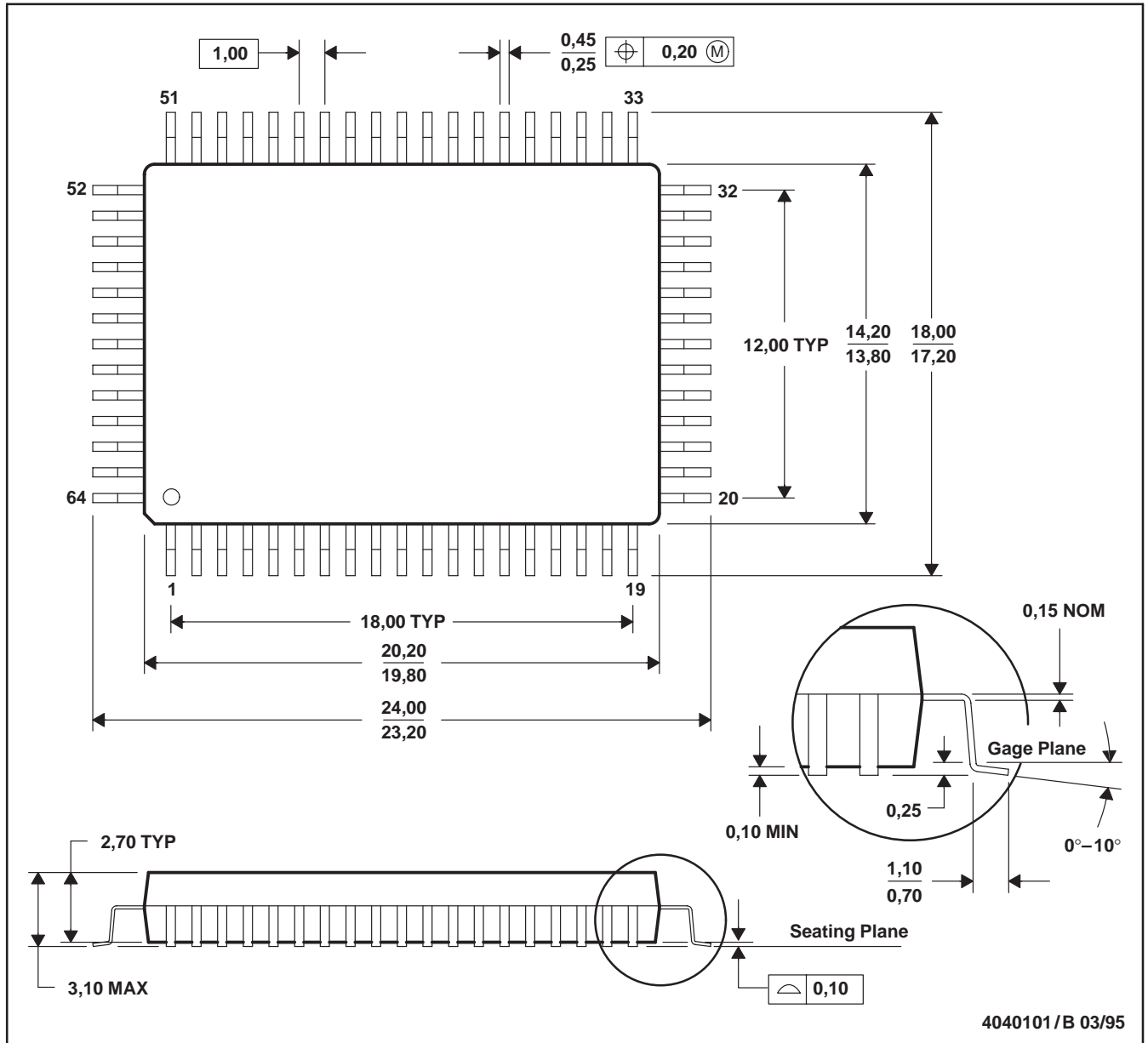

- NOTES: A. All linear dimensions are in millimeters.
 B. This drawing is subject to change without notice.
 C. Contact field sales office to determine if a tighter coplanarity requirement is available for this package.

PAG (S-PQFP-G64)

PLASTIC QUAD FLATPACK

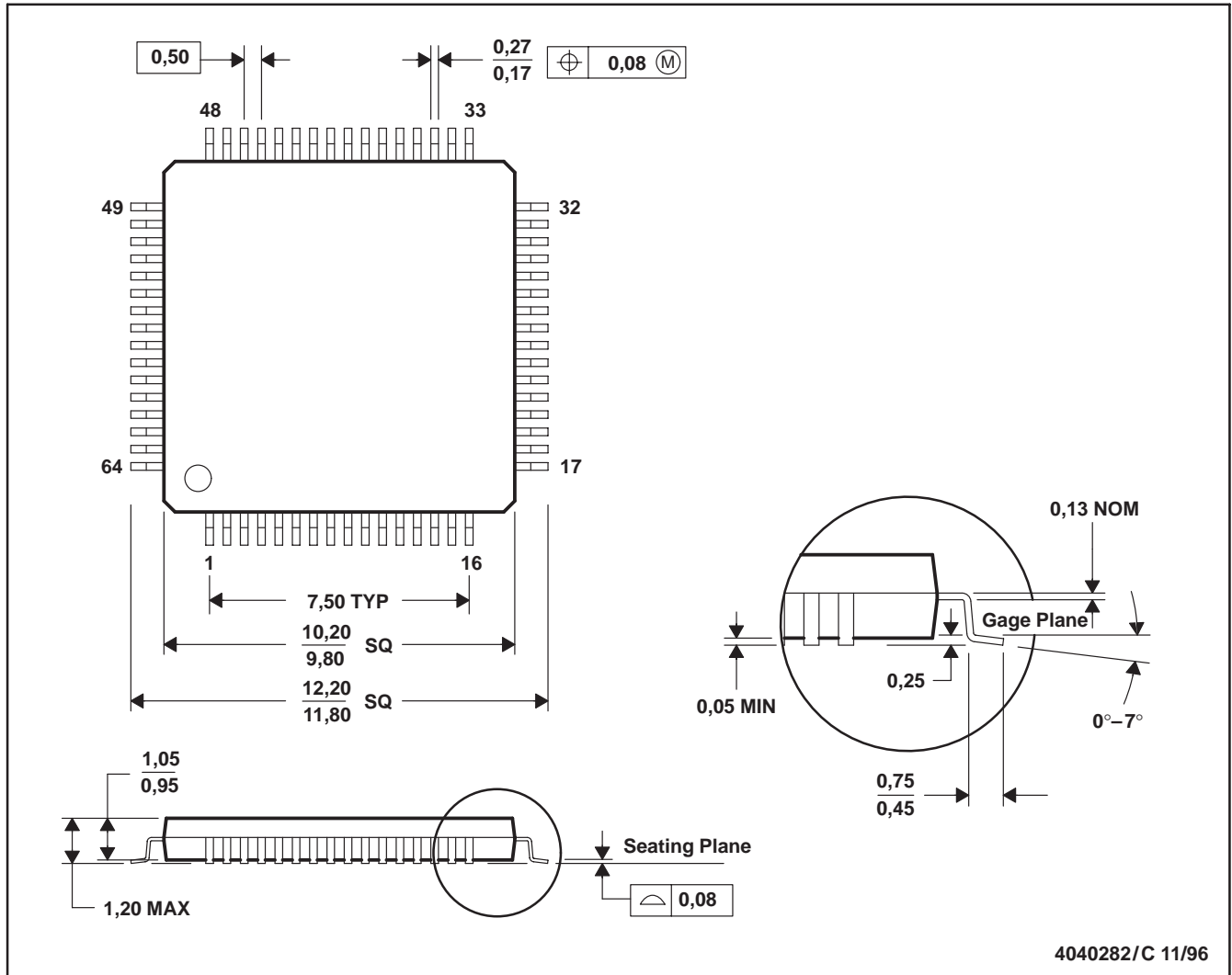

4040282/C 11/96

- NOTES: A. All linear dimensions are in millimeters.
 B. This drawing is subject to change without notice.
 C. Falls within JEDEC MS-026

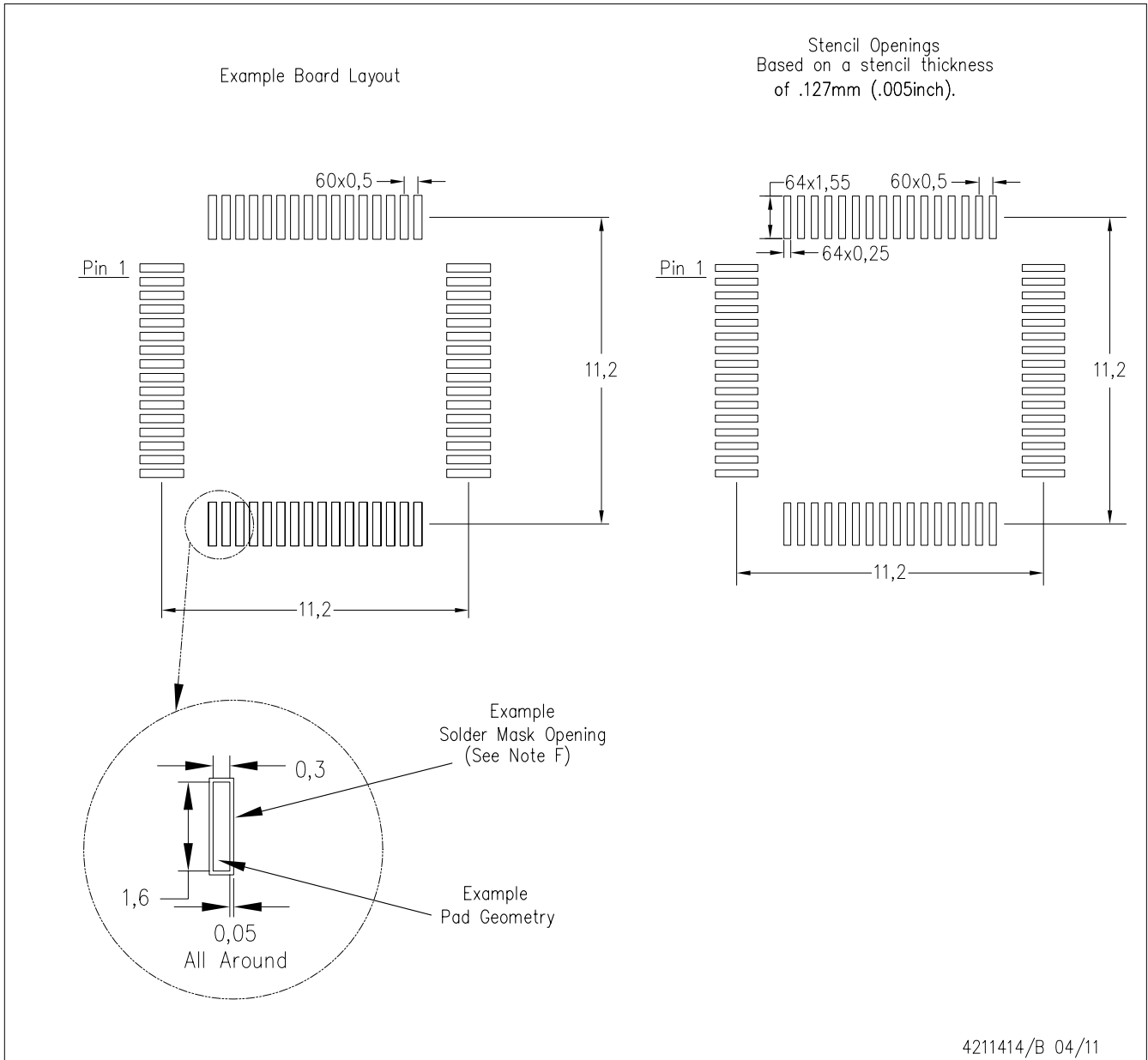

- NOTES:
- A. All linear dimensions are in millimeters.
 - B. This drawing is subject to change without notice.
 - C. Laser cutting apertures with trapezoidal walls and also rounding corners will offer better paste release. Customers should contact their board assembly site for stencil design recommendations. Example stencil design based on a 50% volumetric metal load solder paste. Refer to IPC-7525 for other stencil recommendations.
 - D. Customers should contact their board fabrication site for solder mask tolerances between and around signal pads.

PZ (S-PQFP-G100)

PLASTIC QUAD FLATPACK

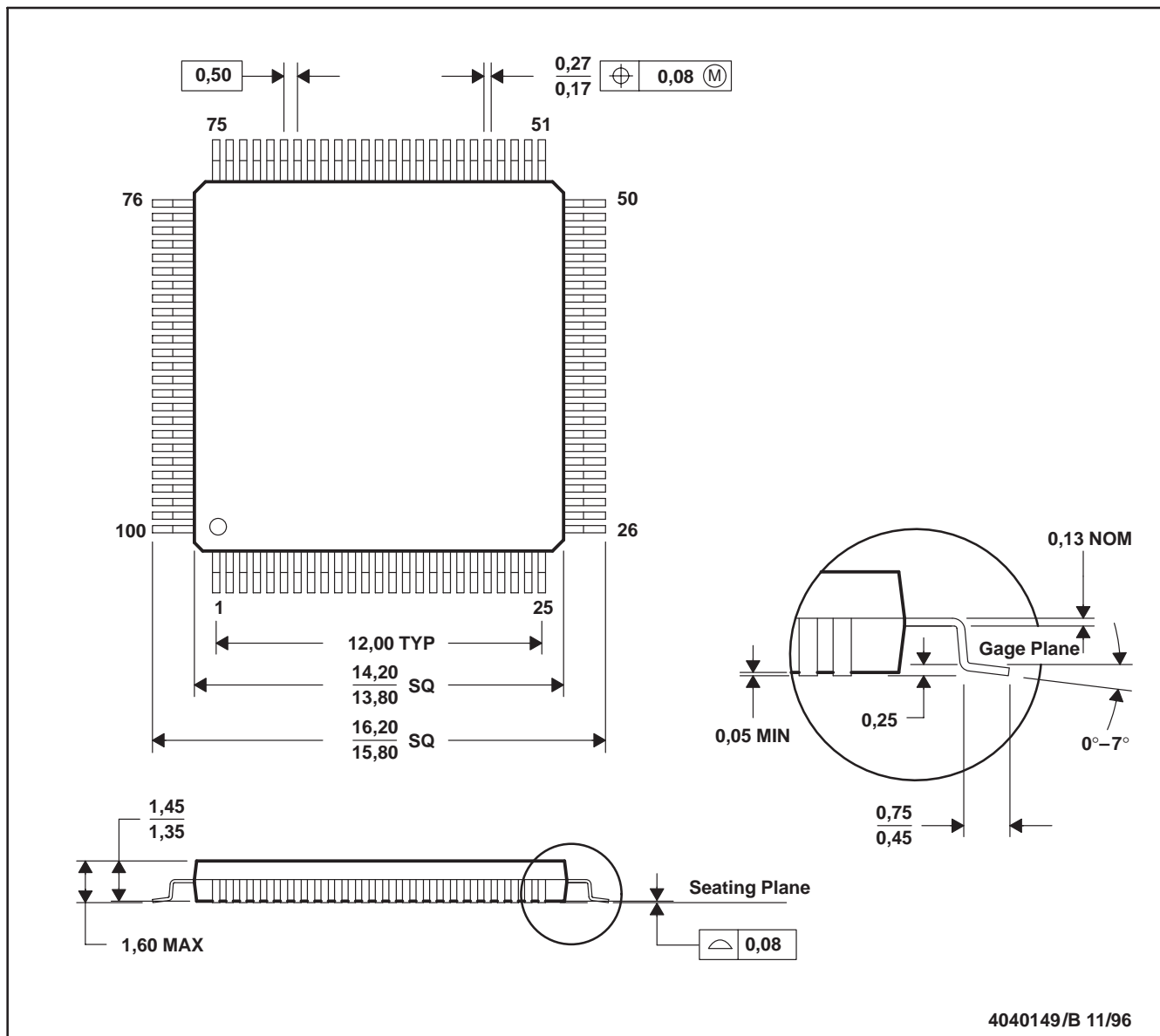

- NOTES: A. All linear dimensions are in millimeters.
 B. This drawing is subject to change without notice.
 C. Falls within JEDEC MS-026

PGE (S-PQFP-G144)

PLASTIC QUAD FLATPACK

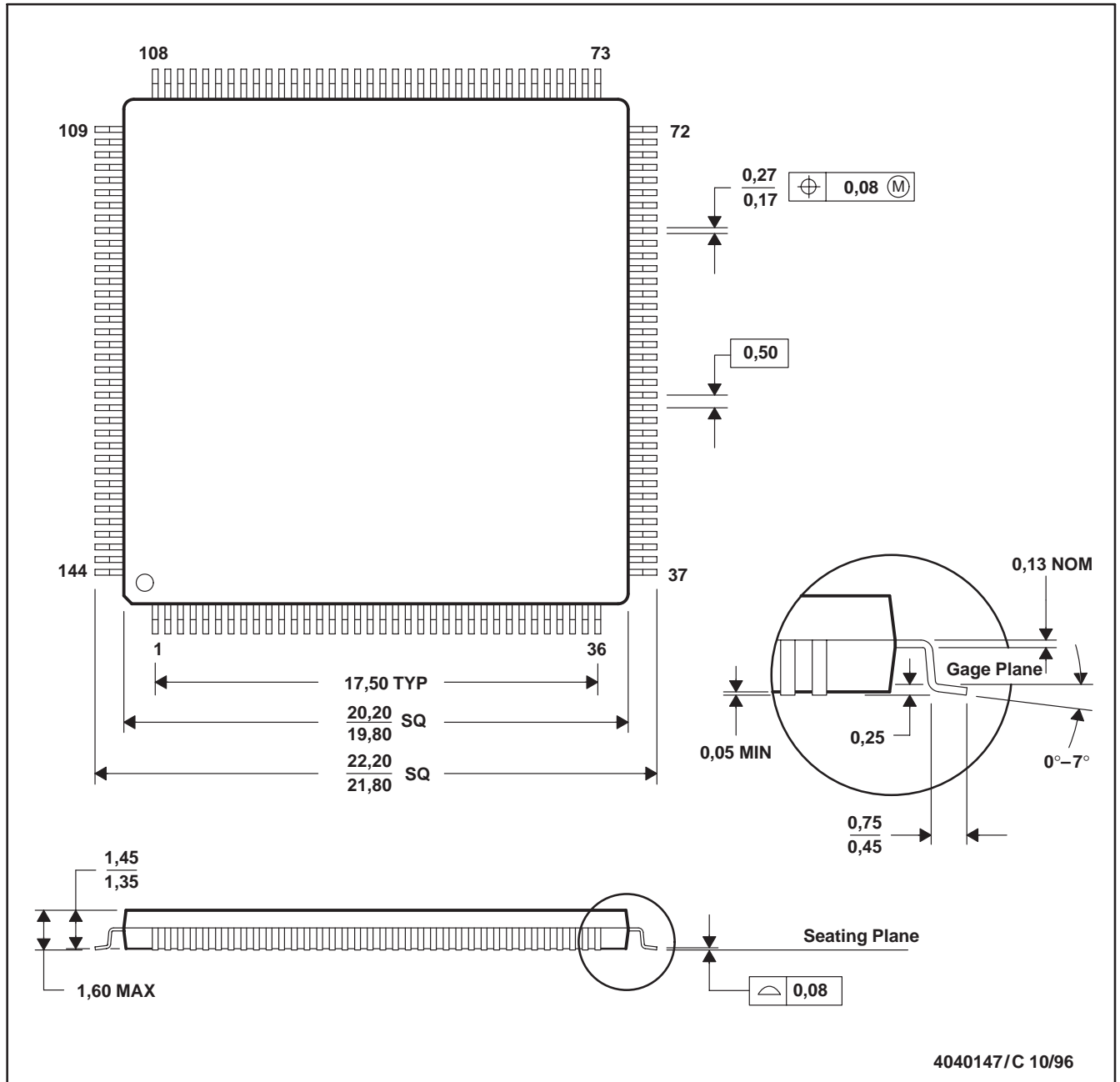

- NOTES: A. All linear dimensions are in millimeters.
 B. This drawing is subject to change without notice.
 C. Falls within JEDEC MS-026

IMPORTANT NOTICE

Texas Instruments Incorporated and its subsidiaries (TI) reserve the right to make corrections, modifications, enhancements, improvements, and other changes to its products and services at any time and to discontinue any product or service without notice. Customers should obtain the latest relevant information before placing orders and should verify that such information is current and complete. All products are sold subject to TI's terms and conditions of sale supplied at the time of order acknowledgment.

TI warrants performance of its hardware products to the specifications applicable at the time of sale in accordance with TI's standard warranty. Testing and other quality control techniques are used to the extent TI deems necessary to support this warranty. Except where mandated by government requirements, testing of all parameters of each product is not necessarily performed.

TI assumes no liability for applications assistance or customer product design. Customers are responsible for their products and applications using TI components. To minimize the risks associated with customer products and applications, customers should provide adequate design and operating safeguards.

TI does not warrant or represent that any license, either express or implied, is granted under any TI patent right, copyright, mask work right, or other TI intellectual property right relating to any combination, machine, or process in which TI products or services are used. Information published by TI regarding third-party products or services does not constitute a license from TI to use such products or services or a warranty or endorsement thereof. Use of such information may require a license from a third party under the patents or other intellectual property of the third party, or a license from TI under the patents or other intellectual property of TI.

Reproduction of TI information in TI data books or data sheets is permissible only if reproduction is without alteration and is accompanied by all associated warranties, conditions, limitations, and notices. Reproduction of this information with alteration is an unfair and deceptive business practice. TI is not responsible or liable for such altered documentation. Information of third parties may be subject to additional restrictions.

Resale of TI products or services with statements different from or beyond the parameters stated by TI for that product or service voids all express and any implied warranties for the associated TI product or service and is an unfair and deceptive business practice. TI is not responsible or liable for any such statements.

TI products are not authorized for use in safety-critical applications (such as life support) where a failure of the TI product would reasonably be expected to cause severe personal injury or death, unless officers of the parties have executed an agreement specifically governing such use. Buyers represent that they have all necessary expertise in the safety and regulatory ramifications of their applications, and acknowledge and agree that they are solely responsible for all legal, regulatory and safety-related requirements concerning their products and any use of TI products in such safety-critical applications, notwithstanding any applications-related information or support that may be provided by TI. Further, Buyers must fully indemnify TI and its representatives against any damages arising out of the use of TI products in such safety-critical applications.

TI products are neither designed nor intended for use in military/aerospace applications or environments unless the TI products are specifically designated by TI as military-grade or "enhanced plastic." Only products designated by TI as military-grade meet military specifications. Buyers acknowledge and agree that any such use of TI products which TI has not designated as military-grade is solely at the Buyer's risk, and that they are solely responsible for compliance with all legal and regulatory requirements in connection with such use.

TI products are neither designed nor intended for use in automotive applications or environments unless the specific TI products are designated by TI as compliant with ISO/TS 16949 requirements. Buyers acknowledge and agree that, if they use any non-designated products in automotive applications, TI will not be responsible for any failure to meet such requirements.

Following are URLs where you can obtain information on other Texas Instruments products and application solutions:

Products

Audio	www.ti.com/audio
Amplifiers	amplifier.ti.com
Data Converters	dataconverter.ti.com
DLP® Products	www.dlp.com
DSP	dsp.ti.com
Clocks and Timers	www.ti.com/clocks
Interface	interface.ti.com
Logic	logic.ti.com
Power Mgmt	power.ti.com
Microcontrollers	microcontroller.ti.com
RFID	www.ti-rfid.com
OMAP Mobile Processors	www.ti.com/omap
Wireless Connectivity	www.ti.com/wirelessconnectivity

Applications

Communications and Telecom	www.ti.com/communications
Computers and Peripherals	www.ti.com/computers
Consumer Electronics	www.ti.com/consumer-apps
Energy and Lighting	www.ti.com/energy
Industrial	www.ti.com/industrial
Medical	www.ti.com/medical
Security	www.ti.com/security
Space, Avionics and Defense	www.ti.com/space-avionics-defense
Transportation and Automotive	www.ti.com/automotive
Video and Imaging	www.ti.com/video

TI E2E Community Home Page

e2e.ti.com

Mailing Address: Texas Instruments, Post Office Box 655303, Dallas, Texas 75265
Copyright © 2011, Texas Instruments Incorporated