

TMS320F2837xD Dual-Core Delfino™ Microcontrollers

1 Device Overview

1.1 Features

- Dual-Core Architecture
 - Two TMS320C28x 32-Bit CPUs
 - 200 MHz (5-ns Cycle Time)
 - IEEE 754 Single-Precision Floating-Point Unit (FPU)
 - Trigonometric Math Unit (TMU)
 - Viterbi/Complex Math Unit (VCU-II)
 - 16 x 16 and 32 x 32 MAC Operations
 - 16 x 16 Dual MAC
 - Three 32-Bit CPU Timers per Core
 - Harvard Bus Architecture
 - Fast Interrupt Response and Processing
 - Unified Memory Programming Model
- Two Programmable Control Law Accelerators (CLAs)
 - 200 MHz (5-ns Cycle Time)
 - 32-Bit Floating-Point Math Accelerator (IEEE 754 Single Precision)
 - Executes Code Independently of Main CPU
- On-Chip Memory
 - Up to 1MB Flash, Up to 204KB RAM
 - Boot ROM (64KB)
 - Serial Peripheral Interface (SPI), Inter-Integrated Circuit (I²C), Controller Area Network (CAN), and Parallel I/O Software Boot Modes
 - Standard Math Tables
- System Peripherals
 - Dual 32- and 16-Bit EMIF With ASRAM and SDRAM Support
 - Dual 6-Channel DMA Controller
 - Up to 169 Individually Programmable, Multiplexed General-Purpose Input/Output (GPIO) Pins With Input Filtering
- Communications Peripherals
 - USB 2.0 + PHY Port
 - Support for 12-Pin 3.3 V-Compatible Universal Parallel Port (uPP) Interface
 - Two CAN-Bus Ports (32 Mailboxes Each)
 - Three High-Speed (40-MHz) SPI Ports With 16-Level FIFO, DMA Support, and CLA-Accessible
 - Two Multichannel Buffered Serial Ports (McBSPs)
 - Four Serial Communications Interfaces (SCIs)
 - Two I²C Interfaces
- Analog Subsystem
 - Four Dual-Mode Analog-to-Digital Converters (ADCs)
 - 16-Bit Mode
 - 1.1 MSPS Each (Up to 4.4-MSPS System)
 - Differential
 - External Reference
 - Up to 12 External Channels
 - 12-Bit Mode
 - 3.5 MSPS Each (Up to 14-MSPS System)
 - Single-Ended or Differential
 - External Reference
 - Up to 24 External Channels
 - Single Sample-and-Hold (S/H) (Four-Simultaneous-S/H System)
 - Integrated Post-Processing of ADC Conversions
 - Saturating Offset Calibration
 - Error From Setpoint Calculation
 - High, Low, and Zero-Crossing Compare, With Interrupt Capability
 - Trigger-to-Sample Delay Capture
 - Analog Comparator/Digital-to-Analog Converter (DAC) Subsystem With Glitch Filter, for Windowed Trip Monitor and PCMC Interfaces
 - Eight Windowed Comparators With 12-Bit DAC References
 - Three 12-Bit Buffered DAC Outputs
- Enhanced Control Peripherals
 - 24 PWM Channels With Enhanced Features
 - 16 High-Resolution PWM Channels
 - High-Resolution on Both A and B Channels of 8 PWM Modules
 - Dead-Band Support (on Both Standard and High-Resolution)
 - Six Enhanced Capture (eCAP) Modules
 - Three Enhanced Quadrature Encoder Pulse (eQEP) Modules
 - Two Sigma-Delta Filter Modules With up to 8 Input Channels, and PWM Synchronization
- Expanded Peripheral Interrupt (ePIE) Block
 - Supports up to 192 Peripheral Interrupts
 - GPIO Pins can be Connected to 5 Core Interrupts
- JTAG Boundary Scan Support ⁽¹⁾

(1) IEEE Standard 1149.1-1990 Standard Test Access Port and Boundary Scan Architecture



- Advanced Emulation Features
 - Analysis and Breakpoint Functions
 - Two Hardware Breakpoints per CPU
 - Real-Time Debug via Hardware
- Independent Dual-Zone Security per CPU
 - 128-Bit Security Key and Lock
 - Protects Flash, One-Time Programmable (OTP) Memory, and RAM Blocks
- Safety and Reliability Features
 - Error Correction Code (ECC) on Flash, ECC or Parity on RAMs
 - Missing Clock Detection
 - Hardware Built-In Self-Test (for CPUs)
 - Programmable Built-In Self-Test (for Memory)
- Low-Power Modes and Power Savings
 - IDLE, STANDBY, HALT, and HIBERNATE Modes Supported
 - Disable Individual Peripheral Clocks
- Clock and System Control
 - Two Internal Zero-Pin 10-MHz Oscillators
 - On-Chip Crystal Oscillator/External Clock Input
- Dynamic Phase-Locked Loop (PLL) Ratio Changes Supported
- Watchdog Timer Module
- Missing Clock Detection Circuitry
- 1.2-V Core, 3.3-V I/O Design
- Development Support Includes
 - ANSI C/C++ Compiler/Assembler/Linker
 - Code Composer Studio™ IDE
 - DSP/BIOS™ and SYS/BIOS
 - Digital Motor Control and Digital Power Libraries
- Package Options:
 - Lead-Free, Green Packaging
 - 337-Ball New Fine Pitch Ball Grid Array (nFBGA) [ZWT Suffix]
 - 176-Pin PowerPAD™ Thermally Enhanced Low-Profile Quad Flatpack (HLQFP) [PTP Suffix]
- Temperature Options:
 - T: –40°C to 105°C
 - S: –40°C to 125°C
 - Q: –40°C to 125°C (Q100 Qualification for Automotive Applications)

1.2 Applications

- Industrial Drives
- Solar Micro Inverters and Converters
- Radar
- Digital Power
- Smart Metering
- Automotive Transportation
- Power Line Communications
- Software-Defined Radio

1.3 Description

The Delfino TMS320F2837xD device is a dual-core microcontroller with integrated analog features and communications interfaces. The dual real-time control subsystems are based on TI's industry-leading 32-bit TMS320C28x Floating-Point CPUs and feature two CLAs that provide additional flexibility to designers who are interested in doing applications such as running parallel control algorithms and much more. Designers can realize up to 800 MIPS of total system performance.

The TMS320F2837xD device introduces the TMU, which is an accelerator that greatly reduces the number of cycles required to perform common trigonometric functions. The TMS320F2837xD device also has a second-generation Viterbi Complex Math Unit, VCU-II, with improved acceleration on Viterbi operations, complex multiplies, and the CRC engine.

The TMS320F2837xD device supports up to 1MB of ECC-protected on-board flash memory and up to 204KB of SRAM with either ECC or parity. Two independent security zones are also available for 128-bit code protection. High-precision control peripherals such as enhanced pulse width modulators (ePWMs) with fault protection, encoders, and captures are also included.

The analog subsystem boasts up to four 16-bit ADCs as well as eight comparator subsystems (CMPSSs). Each comparator subsystem contains two comparators and a built-in 12-bit DAC reference. Each comparator subsystem can be used as peak-current-mode comparators or as windowed comparators. In addition, the device has three 12-bit DACs.

Connectivity peripherals such as dual external memory interfaces (EMIFs), dual CAN 2.0 interfaces, and a new uPP are also available. The uPP is a high-speed, parallel data bus that allows direct connection to FPGAs or other devices with similar interfaces. A USB 2.0 port with MAC and PHY lets users add USB connectivity to their application.

Device Information⁽¹⁾

PART NUMBER	PACKAGE	BODY SIZE
TMS320F28377DZWT	nFBGA (337)	16,0 mm x 16,0 mm
TMS320F28377DPTP	HLQFP (176)	24,0 mm x 24,0 mm
TMS320F28376DZWT	nFBGA (337)	16,0 mm x 16,0 mm
TMS320F28376DPTP	HLQFP (176)	24,0 mm x 24,0 mm
TMS320F28375DZWT	nFBGA (337)	16,0 mm x 16,0 mm
TMS320F28375DPTP	HLQFP (176)	24,0 mm x 24,0 mm
TMS320F28374DZWT	nFBGA (337)	16,0 mm x 16,0 mm
TMS320F28374DPTP	HLQFP (176)	24,0 mm x 24,0 mm

(1) For more information, see [Section 8](#), Mechanical Packaging and Orderable Information.

1.4 Functional Block Diagram

Figure 1-1 shows the CPU system and associated peripherals comprising the TMS320F2837xD device.

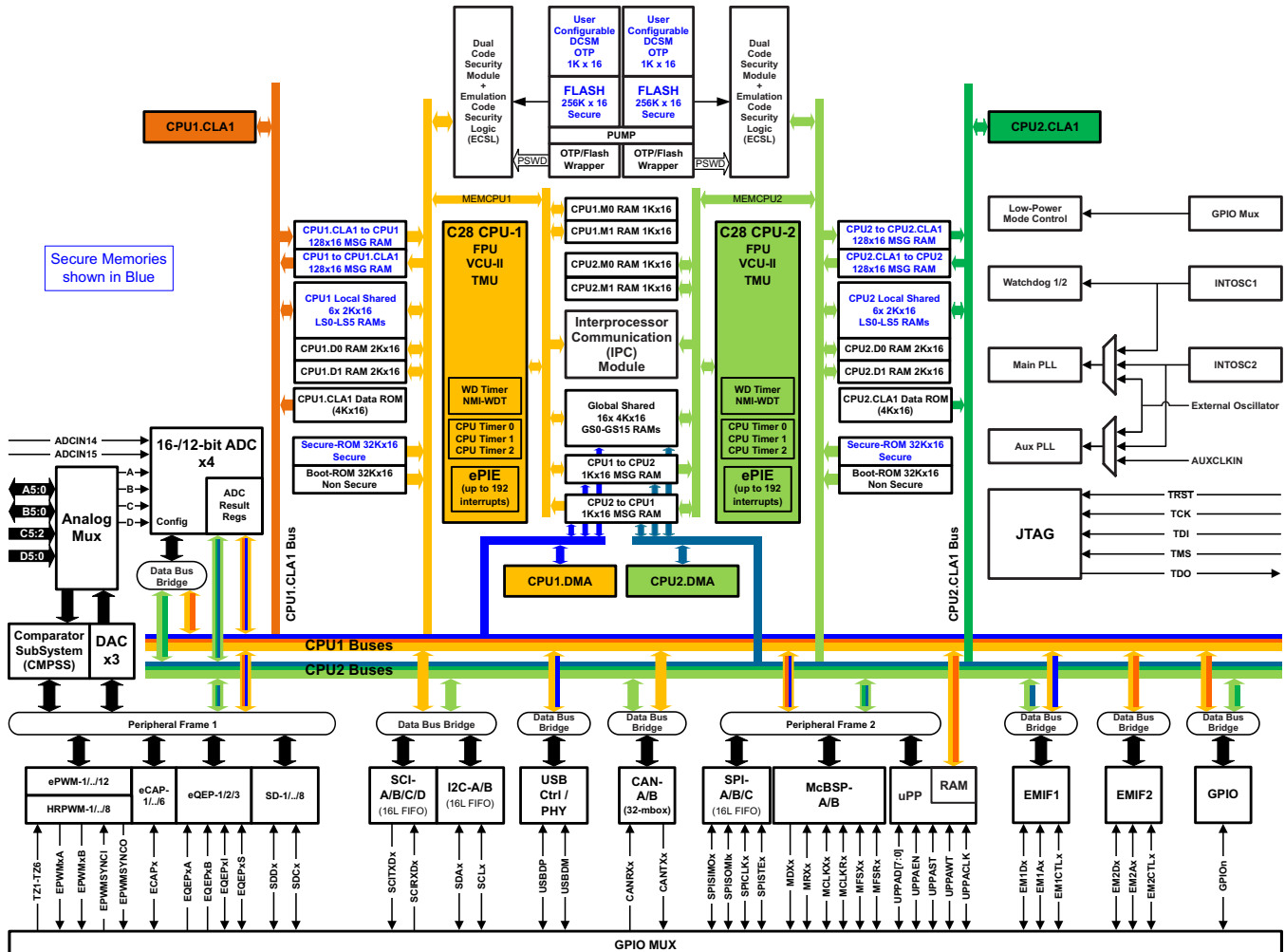

Figure 1-1. Functional Block Diagram

ADVANCE INFORMATION

Table of Contents

1	Device Overview	1	6	Detailed Description	62
	1.1 Features	1		6.1 Functional Block Diagram	62
	1.2 Applications	2		6.2 Memory Maps	64
	1.3 Description	3		6.3 Device Identification Registers	68
	1.4 Functional Block Diagram	4		6.4 Bus Architecture – Peripheral Connectivity	69
2	Revision History	6		6.5 CPU and System Control	70
3	Device Comparison	13		6.6 Peripheral Information and Timings	83
4	Terminal Configuration and Functions	15	7	Device and Documentation Support	110
	4.1 Signal Descriptions	20		7.1 Device Support	110
	4.2 Pin Multiplexing	42		7.2 Documentation Support	112
5	Specifications	46		7.3 Related Links	113
	5.1 Absolute Maximum Ratings	46		7.4 Community Resources	113
	5.2 Recommended Operating Conditions	46		7.5 Trademarks	113
	5.3 Electrical Characteristics	47		7.6 Electrostatic Discharge Caution	113
	5.4 Handling Ratings	47		7.7 Glossary	113
	5.5 Timing and Switching Characteristics	48	8	Mechanical Packaging and Orderable	
	5.6 Power Sequencing	50		Information	114
	5.7 Current Consumption	51		8.1 Packaging Information	114
	5.8 Clocking	53			

2 Revision History

NOTE: Page numbers for previous revisions may differ from page numbers in the current version.

This data sheet revision history highlights the technical changes made to the SPRS880 device-specific data sheet to make it an SPRS880A revision.

- Scope:** Added TMS320F28375D and TMS320F28374D devices.
 Changed total RAM of 28376D from 82KW to 86KW.
 The 28376D device is now available in the Q temperature range (–40°C to 125°C, Q100 qualification for automotive application).
 Added [Section 7.3](#), Related Links, which provides quick access to available resources.
 Restructured document.
 See the following table.

LOCATION	ADDITIONS, DELETIONS, AND MODIFICATIONS
Global	<ul style="list-style-type: none"> Added TMS320F28375D and TMS320F28374D devices Changed total RAM of 28376D from 82KW to 86KW Removed USB OTG feature Removed USBVBUS and USBID pins Removed EM1A20 and EM1A21 pins Replaced XTRIPOUTx with OUTPUTXBARx (for example, replaced XTRIPOUT1 with OUTPUTXBAR1, and so forth) Changed ADCINCAL0 to ADCIN14 Changed ADCINCAL1 to ADCIN15 Added OUTPUTXBAR5 to GPIO7 and GPIO28 Added OUTPUTXBAR6 to GPIO9 and GPIO29 Replaced "user OTP" with "user configurable DCSM OTP" Restructured document
Section 1	Changed title from "TMS320F2837xD Dual-Core Delfino MCUs" to "Device Overview"
Section 1.1	Features: <ul style="list-style-type: none"> Removed "Self-Test and Real-Time Self-Test BIST" feature Added "Hardware Built-In Self-Test (for CPUs)" feature Added "Programmable Built-In Self-Test (for Memory)" feature
Section 1.3	Description: <ul style="list-style-type: none"> Updated "The TMS320F2837xD device supports up to 1MB of ECC-protected on-board flash memory ..." paragraph Removed OTG feature of USB 2.0 port Added "Device Information" table
Figure 1-1	Functional Block Diagram: <ul style="list-style-type: none"> Changed "User OTP 1K x 16" blocks to "User Configurable DCSM OTP 1K x 16" blocks CPU2 Local Shared block: Changed "2Kx16" to "6x 2Kx16" Changed ADCINCAL0 to ADCIN14 Changed ADCINCAL1 to ADCIN15 USB Ctrl / PHY block: Removed USBVBUS and USBID
Section 3	Changed title from "Device Overview" to "Device Comparison"
Table 3-1	Changed title from "TMS320F2837xD Hardware Features" to "Device Comparison Table"
Table 3-1	Device Comparison Table: <ul style="list-style-type: none"> Added 28375D and 28374D data Changed total RAM of 28376D from 82KW to 86KW Removed Power-on reset (POR) Changed "Temperature options" to "Free-Air Temperature (T_A) options" Changed availability of 28376D in Q temperature range to "Yes"
Section 4	Changed title from "Device Pins" to "Terminal Configuration and Functions"

LOCATION	ADDITIONS, DELETIONS, AND MODIFICATIONS
Figure 4-1	337-Ball ZWT New Fine Pitch Ball Grid Array (Bottom View) – [Quadrant A]: <ul style="list-style-type: none"> • Ball T4: Changed ADCINCAL0 to ADCIN14 • Ball U4: Changed ADCINCAL1 to ADCIN15
Figure 4-5	176-Pin PTP PowerPAD Thermally Enhanced Low-Profile Quad Flatpack (Top View): <ul style="list-style-type: none"> • Pin 44: Changed ADCINCAL0 to ADCIN14 • Pin 45: Changed ADCINCAL1 to ADCIN15
Section 4.1	Changed title from "Terminal Functions" to "Signal Descriptions"
Section 4.1	Signal Descriptions: <ul style="list-style-type: none"> • Removed "Unless otherwise mentioned, inputs are not 5-V tolerant" sentence from paragraph
Table 4-1	Changed title from "Terminal Functions" to "Signal Descriptions"

LOCATION	ADDITIONS, DELETIONS, AND MODIFICATIONS
Table 4-1	<p>Signal Descriptions:</p> <ul style="list-style-type: none"> • Replaced XTRIPOUTx with OUTPUTXBARx (for example, replaced XTRIPOUT1 with OUTPUTXBAR1, and so forth) • OUTPUTXBAR1: Updated DESCRIPTION • OUTPUTXBAR2: Updated DESCRIPTION • OUTPUTXBAR3: Updated DESCRIPTION • OUTPUTXBAR4: Updated DESCRIPTION • OUTPUTXBAR5: Updated DESCRIPTION • OUTPUTXBAR6: Updated DESCRIPTION • OUTPUTXBAR7: Updated DESCRIPTION • OUTPUTXBAR8: Updated DESCRIPTION • V_{REFHIA}: Updated DESCRIPTION • V_{REFHIB}: Updated DESCRIPTION • V_{REFHIC}: Updated DESCRIPTION • V_{REFHID}: Updated DESCRIPTION • Changed ADCINCAL0 to ADCIN14 • ADCIN14: Updated DESCRIPTION • Changed ADCINCAL1 to ADCIN15 • ADCIN15: Updated DESCRIPTION • GPIO0: Removed "This pin is 5V-tolerant" from DESCRIPTION • GPIO1: Removed "This pin is 5V-tolerant" from DESCRIPTION • GPIO2: Removed "This pin is 5V-tolerant" from DESCRIPTION • GPIO3: Removed "This pin is 5V-tolerant" from DESCRIPTION • GPIO4: Removed "This pin is 5V-tolerant" from DESCRIPTION • GPIO5: Removed "This pin is 5V-tolerant" from DESCRIPTION • GPIO6: Removed "This pin is 5V-tolerant" from DESCRIPTION • GPIO7: Removed "This pin is 5V-tolerant" from DESCRIPTION • GPIO7 muxed signal: Added OUTPUTXBAR5 • GPIO9 muxed signal: Added OUTPUTXBAR6 • EPWM9A: Removed "and HRPWM channel" from DESCRIPTION • EPWM9B: Removed "and HRPWM channel" from DESCRIPTION • EPWM10A: Removed "and HRPWM channel" from DESCRIPTION • EPWM10B: Removed "and HRPWM channel" from DESCRIPTION • EPWM11A: Removed "and HRPWM channel" from DESCRIPTION • EPWM11B: Removed "and HRPWM channel" from DESCRIPTION • EPWM12A: Removed "and HRPWM channel" from DESCRIPTION • EPWM12B: Removed "and HRPWM channel" from DESCRIPTION • GPIO28 muxed signal: Added OUTPUTXBAR5 • GPIO29 muxed signal: Added OUTPUTXBAR6 • GPIO42: Removed "This pin is 5V-tolerant" from DESCRIPTION • GPIO43: Removed "This pin is 5V-tolerant" from DESCRIPTION • GPIO46: Removed "This pin is 5V-tolerant" from DESCRIPTION • GPIO46 muxed signal: Removed USB0VBUS • GPIO47: Removed "This pin is 5V-tolerant" from DESCRIPTION • GPIO47 muxed signal: Removed USB0ID • GPIO93 muxed signal: Removed EM1A20 • GPIO94 muxed signal: Removed EM1A21 • X1: Updated DESCRIPTION • TCK: Updated DESCRIPTION • VREGENZ: Updated DESCRIPTION • ERRORSTS: Updated DESCRIPTION
Section 4.2	Added "Pin Multiplexing" section

LOCATION	ADDITIONS, DELETIONS, AND MODIFICATIONS
Table 4-2	GPIO Muxed Pins: <ul style="list-style-type: none"> Replaced XTRIPOUTx with OUTPUTXBARx (for example, replaced XTRIPOUT1 with OUTPUTXBAR1, and so forth) GPIO7: Added OUTPUTXBAR5 to "11b" column GPIO9: Added OUTPUTXBAR6 to "11b" column GPIO28: Added OUTPUTXBAR5 to "01b" column GPIO29: Added OUTPUTXBAR6 to "01b" column GPIO46: Removed USB0VBUS from Alternate Function column GPIO47: Removed USBID from Alternate Function column GPIO93: Removed EM1A20 from "10b" column GPIO94: Removed EM1A21 from "10b" column Added footnote about GPIO Index settings
Section 5	Changed title from "Device Operating Conditions" to "Specifications"
Section 5.1	Absolute Maximum Ratings: <ul style="list-style-type: none"> Removed "Input voltage range, V_{IN} (5 V)"
Section 5.2	Recommended Operating Conditions: <ul style="list-style-type: none"> Removed "High-level input voltage, V_{IH} (5V-tolerant IOs)" parameter Moved the following to Section 5.3, Electrical Characteristics: <ul style="list-style-type: none"> High-level input voltage, V_{IH} (3.3 V) Low-level input voltage, V_{IL} (3.3 V) High-level output source current, I_{OH}, for all GPIO pins Low-level output sink current, I_{OL}, for all GPIO pins
Section 5.3	Electrical Characteristics: <ul style="list-style-type: none"> Updated I_{IL} Updated I_{IH} Added the following from Section 5.2, Recommended Operating Conditions: <ul style="list-style-type: none"> High-level input voltage, V_{IH} (3.3 V) Low-level input voltage, V_{IL} (3.3 V) High-level output source current, I_{OH}, for all GPIO pins Low-level output sink current, I_{OL}, for all GPIO pins
Section 5.4	Added "Handling Ratings" section
Section 5.5	Added "Timing and Switching Characteristics" section
Section 5.5	Timing and Switching Characteristics: <ul style="list-style-type: none"> Added Section 5.5.1, Flash Timing Added Section 5.5.2, ADC Electrical Data and Timing Added Section 5.5.3, Temperature Sensor Electrical Data and Timing Added Section 5.5.4, Buffered DAC Electrical Data and Timing Added Section 5.5.5, CMPSS Electrical Data and Timing
Table 5-2	Minimum Required Flash/OTP Wait-States at Different Frequencies for CPU1 Subsystem and CPU2 Subsystem: <ul style="list-style-type: none"> Changed column header from "SYSCLKOUT (MHz)" to "CPUCLK (MHz)" Changed column header from "SYSCLKOUT (ns)" to "CPUCLK (ns)"
Table 5-3	ADC Characteristics (16-Bit Mode): <ul style="list-style-type: none"> Added "Relative to 2.5-V V_{REFHI}/V_{REFLO} range" footnote
Table 5-6	Buffered DAC Electrical Characteristics: <ul style="list-style-type: none"> Added R_{PD}
Section 5.6	Added "Power Sequencing" section
Table 5-9	Typical Current Consumption at 200 MHz: <ul style="list-style-type: none"> Removed "VREG DISABLED" column header
Section 5.8.1	Clock Sources: <ul style="list-style-type: none"> Added NOTE about "PERx.SYSCLK" being used interchangeably with "SYSCLKOUT" below Figure 5-1
Figure 5-1	Updated "Clocking Options for System PLL" figure
Figure 5-2	Updated "Clocking Options for Auxiliary PLL" figure
Figure 5-3	Updated "Peripheral Clock Options" figure

LOCATION	ADDITIONS, DELETIONS, AND MODIFICATIONS
Table 5-12	Added "Crystal Equivalent Series Resistance (ESR) Requirements" table
Table 5-13	Changed title from "X1 Timing Requirements - PLL Enabled" to "X1 Timing Requirements"
	Removed "X1 Timing Requirements - PLL Disabled" table (this was Table 5-11 in SPRS880)
Table 5-14	Changed title from "XCLKIN Timing Requirements - PLL Enabled" to "AUXCLKIN Timing Requirements"
Table 5-14	AUXCLKIN Timing Requirements: <ul style="list-style-type: none"> Changed "XCLKIN" to "AUXCLKIN" in parameter descriptions
	Removed "XCLKIN Timing Requirements - PLL Disabled" table (this was Table 5-13 in SPRS880)
Table 5-16	Internal Clock Frequencies: <ul style="list-style-type: none"> Added $f_{(EPWM)}$ [Frequency, EPWMCLK]
Section 6.2	Memory Maps: <ul style="list-style-type: none"> Removed "Memory Map" table (this was Table 2-2 in SPRS880) Added Section 6.2.1, RAM Memory Map Added Section 6.2.2, Flash Memory Map Added Section 6.2.3, EMIF Chip Select Memory Map Added Section 6.2.4, Peripheral Registers Memory Map
Section 6.2.2	Flash Memory Map: <ul style="list-style-type: none"> Updated Table 6-2, Addresses of Flash Sectors on CPU1 and CPU2 for F28377D and F28375D Updated Table 6-3, Addresses of Flash Sectors on CPU1 and CPU2 for F28376D and F28374D
Table 6-4	Updated "EMIF Chip Select Memory Map" table
Table 6-6	Device Identification Registers: <ul style="list-style-type: none"> Added TMS320F28375D and TMS320F28374D data
Table 6-7	Bus Master Peripheral Access: <ul style="list-style-type: none"> Peripheral Frame 1: <ul style="list-style-type: none"> Changed "Sigma-Delta Filter Module (SDFM) Demodulator" to "SDFM" Updated uPP Configuration description
Section 6.5.1	C28x Processor: <ul style="list-style-type: none"> Added reference to the <i>TMS320C28x CPU and Instruction Set Reference Guide</i> (literature number SPRU430)
Section 6.5.1.1	Floating-Point Unit: <ul style="list-style-type: none"> Added reference to the <i>TMS320C28x Extended Instruction Sets Reference Guide</i> (literature number SPRUHS1)
Section 6.5.1.2	Trigonometric Math Unit: <ul style="list-style-type: none"> Replaced reference to <i>TMS320C28x Floating Point Unit and Instruction Set Reference Guide</i> (literature number SPRUEO2) with reference to the <i>TMS320C28x Extended Instruction Sets Reference Guide</i> (literature number SPRUHS1)
Table 6-8	TMU Supported Instructions: <ul style="list-style-type: none"> Added PIPELINE CYCLES column
Section 6.5.1.3	Viterbi, Complex Math, and CRC Unit II (VCU-II): <ul style="list-style-type: none"> Revised first two paragraphs Added reference to the <i>TMS320C28x Extended Instruction Sets Reference Guide</i> (literature number SPRUHS1)
Figure 6-2	Updated CLA Block Diagram
Section 6.5.3	Direct Memory Access: <ul style="list-style-type: none"> Added "Each CPU has its own 6-channel DMA module" to first paragraph
Figure 6-3	DMA Block Diagram: <ul style="list-style-type: none"> Changed "SDxFLTy (1-8)" to "SDxFLTy (x = 1 to 2, y = 1 to 4)" Changed "Sigma Delta (2x4)" to "SDFM (8 filter channels)"
Table 6-11	Device Boot Mode – Decoded by CPU1: <ul style="list-style-type: none"> Removed "SUPPORTED IN VERSION 1.0" column
Section 6.5.6.1	Revised "Dedicated RAM (Mx and Dx RAM)" section
Section 6.5.8	Timers: <ul style="list-style-type: none"> Replaced "SYSCLKOUT" with "CPUx.SYSCLK"
Figure 6-6	Updated "Windowed Watchdog" figure

LOCATION	ADDITIONS, DELETIONS, AND MODIFICATIONS
Figure 6-7	Analog Subsystem Block Diagram (337-Ball ZWT): <ul style="list-style-type: none"> Changed ADCINCAL0 to ADCIN14 Changed ADCINCAL1 to ADCIN15
Figure 6-8	Analog Subsystem Block Diagram (176-Pin PTP): <ul style="list-style-type: none"> Changed ADCINCAL0 to ADCIN14 Changed ADCINCAL1 to ADCIN15
Section 6.6.1.2	Buffered Digital-to-Analog Converter: <ul style="list-style-type: none"> Updated list of features: <ul style="list-style-type: none"> Changed "Analog output buffer" to "Analog output buffer with programmable gain setting (Gain = 1 or Gain = 2)"
Section 6.6.2.1	Sigma Delta Filter Module: <ul style="list-style-type: none"> Updated list of SDFM features : <ul style="list-style-type: none"> Changed "PWMs can be used to generate carrier frequency for resolver applications" to "PWMs can be used to generate modulator clock for sigma delta modulators"
Figure 6-12	Updated "SDFM" figure
Section 6.6.2.2	Enhanced Pulse Width Modulator: <ul style="list-style-type: none"> Replaced "type-3" with "type-4"
Figure 6-13	ePWM Sub-Modules Showing Critical Internal Signal Interconnections: <ul style="list-style-type: none"> Updated figure Updated footnote
Figure 6-14	Updated "ePWM" figure
Section 6.6.2.3	High-Resolution Pulse Width Modulator: <ul style="list-style-type: none"> Updated list of key points Updated NOTE: <ul style="list-style-type: none"> Changed "The minimum SYSCLKOUT frequency allowed for HRPWM is 60 MHz" to "The minimum HRPWMCLK frequency allowed for HRPWM is 60 MHz"
Section 6.6.2.4	Enhanced Capture: <ul style="list-style-type: none"> Changed "The clock enable bits (ECAP1 ENCLK) in the PCLKCR1 register turn off the eCAP module individually ..." to "The clock enable bits (ECAP1–ECAP6) in the PCLKCR3 register turn off the eCAP module individually ..."
Section 6.6.3.1	Serial Peripheral Interface: <ul style="list-style-type: none"> Updated "The SPI is a high-speed synchronous serial input/output (I/O) port ..." paragraph Updated "Baud rate: 125 different programmable rates" feature
Figure 6-18	SPI: <ul style="list-style-type: none"> Changed SYSCLKOUT to CPUx.SYSCLK
Figure 6-19	SCI Block Diagram: <ul style="list-style-type: none"> Changed LSPCLK to PERx.LSPCLK
Figure 6-20	I ² C Peripheral Module Interfaces: <ul style="list-style-type: none"> Removed footnotes
Section 6.6.3.4	Multichannel Buffered Serial Port: <ul style="list-style-type: none"> Updated list of features
Figure 6-21	McBSP Block Diagram: <ul style="list-style-type: none"> Changed LSPCLK to PERx.LSPCLK
Section 6.6.3.5	Universal Serial Bus Controller: <ul style="list-style-type: none"> Removed OTG feature Updated list of features
Figure 6-22	USB Block Diagram: <ul style="list-style-type: none"> Changed "AHB bus-Slave mode" to "CPU Bus"
Section 6.6.3.6	Controller Area Network: <ul style="list-style-type: none"> Updated NOTE: Changed "SYSCLKOUT" to "CANx Bit-CLK" Removed "CAN" figure (this was Figure 6-17 in SPRS880)

LOCATION	ADDITIONS, DELETIONS, AND MODIFICATIONS
Section 7	Device and Documentation Support: <ul style="list-style-type: none"> • Added Section 7.3, Related Links • Added "Trademarks" section • Added "Electrostatic Discharge Caution" section • Added "Glossary" section
Section 7.1.1	Development Support: <ul style="list-style-type: none"> • Changed "XDS100" to "XDS100v2" • Added XDS200
Figure 7-1	Device Nomenclature: <ul style="list-style-type: none"> • Added 28375D and 28374D under DEVICE • Removed footnote
Section 7.2	Documentation Support: <ul style="list-style-type: none"> • Added <i>TMS320C28x Extended Instruction Sets Reference Guide</i> (literature number SPRUHS1) • Updated title of SPRU513 • Updated title of SPRU514

3 Device Comparison

Table 3-1 lists the features of the TMS320F2837xD devices.

Table 3-1. Device Comparison Table

FEATURE ⁽¹⁾		28377D		28376D		28375D		28374D	
		337-Ball ZWT	176-Pin PTP	337-Ball ZWT	176-Pin PTP	337-Ball ZWT	176-Pin PTP	337-Ball ZWT	176-Pin PTP
Package Type (ZWT is an nFBGA package. PTP is an HLQFP package.)									
Processor speed (MHz)		200							
Instruction cycle (ns)		5							
FPU		Yes							
VCU-II		Yes							
TMU – Type 0		Yes							
CLA – Type 1		2 (1 per CPU)							
6-Channel Direct Memory Access (DMA) – Type 0		2 (1 per CPU)							
Flash (16-bit words)		512KW (256KW per CPU)		256KW (128KW per CPU)		512KW (256KW per CPU)		256KW (128KW per CPU)	
RAM (16-bit words)	Dedicated and Local Shared RAM	36KW (18KW per CPU)							
	Global Shared RAM	64KW		48KW		64KW		48KW	
	Message RAM	2KW (1KW per CPU)							
	Total RAM	102KW		86KW		102KW		86KW	
Code security for on-chip Flash, RAM, and OTP blocks		Yes							
Boot ROM		Yes							
OTP memory (16-bit words)		2KW							
ePWM Type-4 channels		24							
High-resolution ePWM Type-4 channels		16							
eCAP inputs – Type 0		6							
eQEP modules – Type 0		3							
32-bit CPU timers		6 (3 per CPU)							
Watchdog timers		2 (1 per CPU)							
Nonmaskable Interrupt Watchdog (NMIWD) timers		2 (1 per CPU)							
ADC 16-bit mode	MSPS	1.1				–			
	Conversion Time (ns)	910				–			
	Input pins	24	20	24	20	–			
	Channels (differential)	12	9	12	9	–			
ADC 12-bit mode	MSPS	3.5							
	Conversion Time (ns)	286							
	Input pins	24	20	24	20	24	20	24	20
	Channels (differential/single-ended)	12/24	9/20	12/24	9/20	12/24	9/20	12/24	9/20
Number of 16-bit or 12-bit ADCs		4				–			
Number of 12-bit only ADCs		–				4			
Temperature sensor		1							
CMPSS (each CMPSS has two Comparators and one internal DAC)		8							
Buffered DAC		3							
Sigma-Delta Filter Module (SDFM) channels		8							
I ² C – Type 0		2							
McBSP – Type 1		2							
uPP		1							
CAN – Type 0		2							
SPI – Type 1		3							
SCI – Type 0		4							

ADVANCE INFORMATION

Table 3-1. Device Comparison Table (continued)

FEATURE ⁽¹⁾		28377D		28376D		28375D		28374D	
		337-Ball ZWT	176-Pin PTP	337-Ball ZWT	176-Pin PTP	337-Ball ZWT	176-Pin PTP	337-Ball ZWT	176-Pin PTP
Package Type (ZWT is an nFBGA package. PTP is an HLQFP package.)									
Universal Serial Bus (USB) – Type 0		1							
EMIF	16/32-bit	1							
	16-bit	1	–	1	–	1	–	1	–
On-chip crystal oscillator/External clock input		1							
0-pin internal oscillator		2							
I/O pins (shared)	GPIO	169	97	169	97	169	97	169	97
External interrupts		5							
I/O supply voltage (nominal)		3.3 V							
Core supply voltage (nominal)		1.2 V							
Free-Air Temperature (T _A) options	T: –40°C to 105°C	Yes							
	S: –40°C to 125°C	Yes							
	Q: –40°C to 125°C ⁽²⁾	Yes							
Product status ⁽³⁾		TMX							

(1) A type change represents a major functional feature difference in a peripheral module. Within a peripheral type, there may be minor differences between devices that do not affect the basic functionality of the module.

(2) "Q" refers to Q100 qualification for automotive applications.

(3) The "TMX" product status denotes an experimental device that is not necessarily representative of the final device's electrical specifications.

4 Terminal Configuration and Functions

Figure 4-1 to Figure 4-4 show in four quadrants the terminal assignments on the 337-ball ZWT New Fine Pitch Ball Grid Array. Figure 4-5 shows the pin assignments on the 176-pin PTP PowerPAD Thermally Enhanced Low-Profile Quad Flatpack.

	1	2	3	4	5	6	7	8	9	10	
W	V _{SSA}	ADCINB1	ADCINB3	ADCINB5	V _{REFHIB}	V _{REFLOD}	V _{SS}	V _{DDIO}	GPIO128	GPIO116	W
V	V _{REFHIA}	ADCINB0	ADCINB2	ADCINB4	V _{REFHID}	V _{REFLOB}	V _{SSA}	GPIO124	GPIO127	GPIO131	V
U	ADCINA0	ADCINA2	ADCINA4	ADCIN15	ADCIND1	ADCIND3	ADCIND5	GPIO123	GPIO126	GPIO130	U
T	ADCINA1	ADCINA3	ADCINA5	ADCIN14	ADCIND0	ADCIND2	ADCIND4	GPIO122	GPIO125	GPIO129	T
R	V _{REFHIC}	V _{REFLOA}	ADCINC2	ADCINC4	V _{SSA}	V _{DDA}	V _{SS}	V _{SS}	V _{DDIO}	V _{DD}	R
P	V _{SSA}	V _{REFLOC}	ADCINC3	ADCINC5	V _{SSA}	V _{DDA}	V _{SS}	V _{SS}	V _{DDIO}	V _{DD}	P
N	V _{SS}	GPIO109	GPIO114	GPIO113	V _{SS}	V _{SS}	7 N	8	9	10	N
M	V _{DDIO}	GPIO110	GPIO112	GPIO111	V _{DDIO}	V _{DDIO}	M	V _{SS}	V _{SS}	V _{SS}	M
L	GPIO27	GPIO106	GPIO107	GPIO108	V _{SS}	V _{SS}	L	V _{SS}	V _{SS}	V _{SS}	L
K	GPIO26	GPIO25	GPIO24	GPIO23	V _{DD}	V _{DD}	K	V _{SS}	V _{SS}	V _{SS}	K
	1	2	3	4	5	6		8	9	10	

ADVANCE INFORMATION

A. Only the GPIO function is shown on GPIO terminals. See Table 4-1 for the complete, muxed signal name.

Figure 4-1. 337-Ball ZWT New Fine Pitch Ball Grid Array (Bottom View) – [Quadrant A]

ADVANCE INFORMATION

	11	12	13	14	15	16	17	18	19		
W	GPIO29	FLT1	TDI	TMS	TDO	GPIO121	GPIO39	GPIO132	V _{SS}	W	
V	GPIO28	GPIO115	FLT2	$\overline{\text{TRST}}$	TCK	GPIO36	GPIO40	GPIO134	V _{DDIO}	V	
U	GPIO31	GPIO117	GPIO32	GPIO34	GPIO120	GPIO37	GPIO41	GPIO135	ERRORSTS	U	
T	GPIO30	GPIO118	GPIO33	GPIO35	GPIO119	GPIO38	GPIO136	GPIO137	GPIO138	T	
R	V _{DD3VFL}	V _{DD3VFL}	V _{DD}	V _{SS}	V _{SS}	GPIO48	GPIO49	GPIO50	GPIO51	R	
P	V _{SS}	V _{SS}	V _{DD}	V _{SS}	V _{SS}	GPIO52	GPIO53	GPIO54	GPIO55	P	
	11	12	13	N	V _{DDIO}	V _{DDIO}	GPIO56	GPIO58	GPIO57	GPIO139	N
M	V _{SS}	V _{SS}	M	V _{SS}	V _{SS}	GPIO59	GPIO60	GPIO141	GPIO140	M	
L	V _{SS}	V _{SS}	L	V _{DDIO}	V _{DDIO}	GPIO61	GPIO64	V _{SS}	GPIO142	L	
K	V _{SS}	V _{SS}	K	V _{SS}	V _{SS}	GPIO65	GPIO66	GPIO44	GPIO45	K	

	11	12	14	15	16	17	18	19

A. Only the GPIO function is shown on GPIO terminals. See [Table 4-1](#) for the complete, muxed signal name.

Figure 4-2. 337-Ball ZWT New Fine Pitch Ball Grid Array (Bottom View) – [Quadrant B]

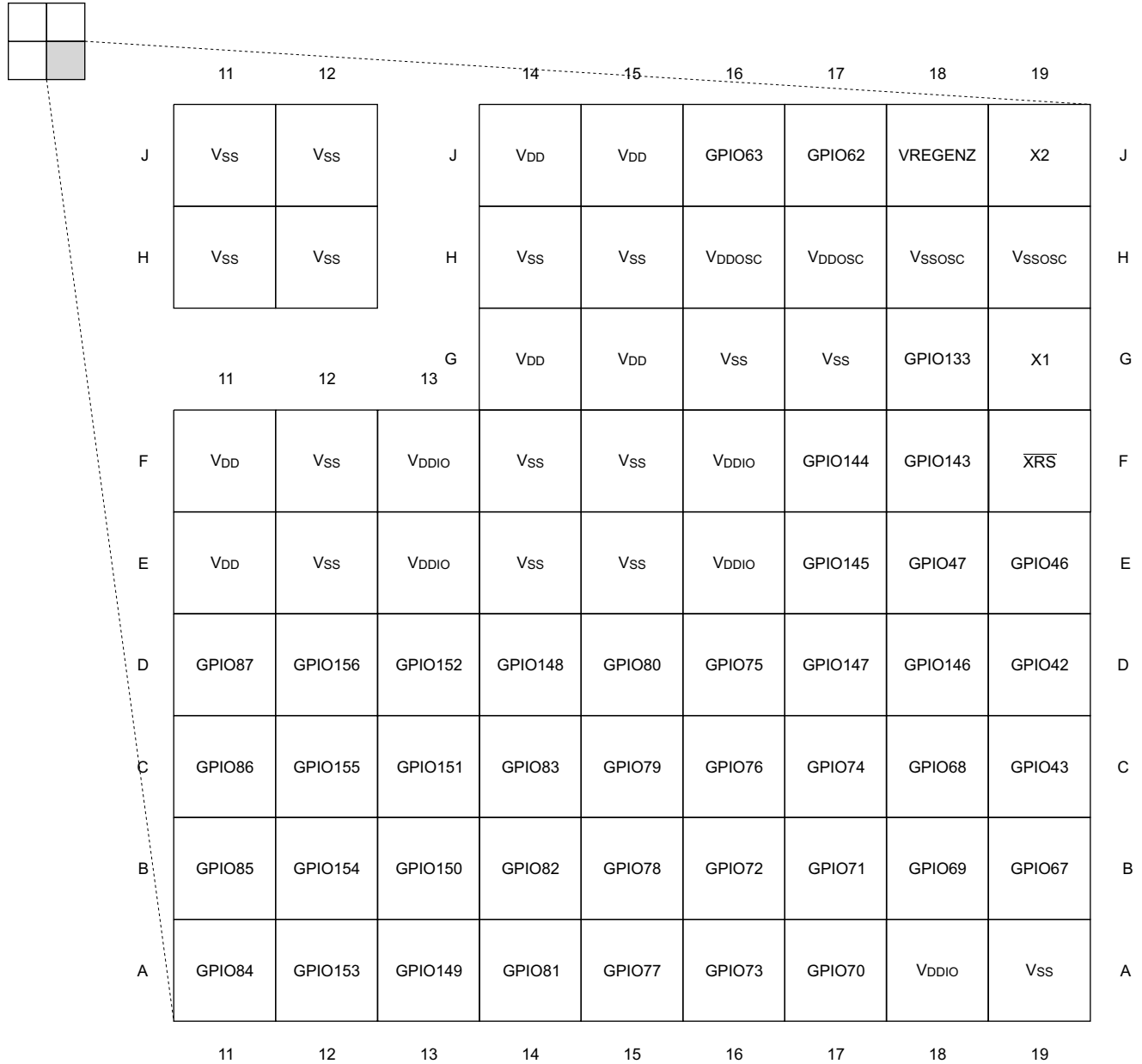

ADVANCE INFORMATION

A. Only the GPIO function is shown on GPIO terminals. See Table 4-1 for the complete, muxed signal name.

Figure 4-3. 337-Ball ZWT New Fine Pitch Ball Grid Array (Bottom View) – [Quadrant C]

ADVANCE INFORMATION

	1	2	3	4	5	6		8	9	10	
J	GPIO103	GPIO104	GPIO105	GPIO22	Vss	Vss	J	Vss	Vss	Vss	J
H	GPIO100	GPIO101	GPIO102	NC	VDDIO	VDDIO	H	Vss	Vss	Vss	H
G	GPIO99	GPIO8	GPIO9	VDDIO	VDDIO	VDDIO	G	7	8	9	10
F	GPIO98	GPIO20	GPIO21	VDDIO	Vss	Vss	VDDIO	Vss	VDD	VDDIO	F
E	GPIO16	GPIO17	GPIO18	GPIO19	Vss	Vss	VDDIO	Vss	VDD	VDDIO	E
D	GPIO13	GPIO14	GPIO15	GPIO168	GPIO166	GPIO89	GPIO5	GPIO1	GPIO162	GPIO159	D
C	GPIO11	GPIO12	GPIO96	GPIO167	GPIO165	GPIO88	GPIO4	GPIO0	GPIO161	GPIO158	C
B	VDDIO	GPIO10	GPIO95	GPIO93	GPIO91	GPIO7	GPIO3	GPIO164	GPIO160	GPIO157	B
A	Vss	GPIO97	GPIO94	GPIO92	GPIO90	GPIO6	GPIO2	GPIO163	VDDIO	Vss	A
	1	2	3	4	5	6	7	8	9	10	

A. Only the GPIO function is shown on GPIO terminals. See [Table 4-1](#) for the complete, muxed signal name.

Figure 4-4. 337-Ball ZWT New Fine Pitch Ball Grid Array (Bottom View) – [Quadrant D]

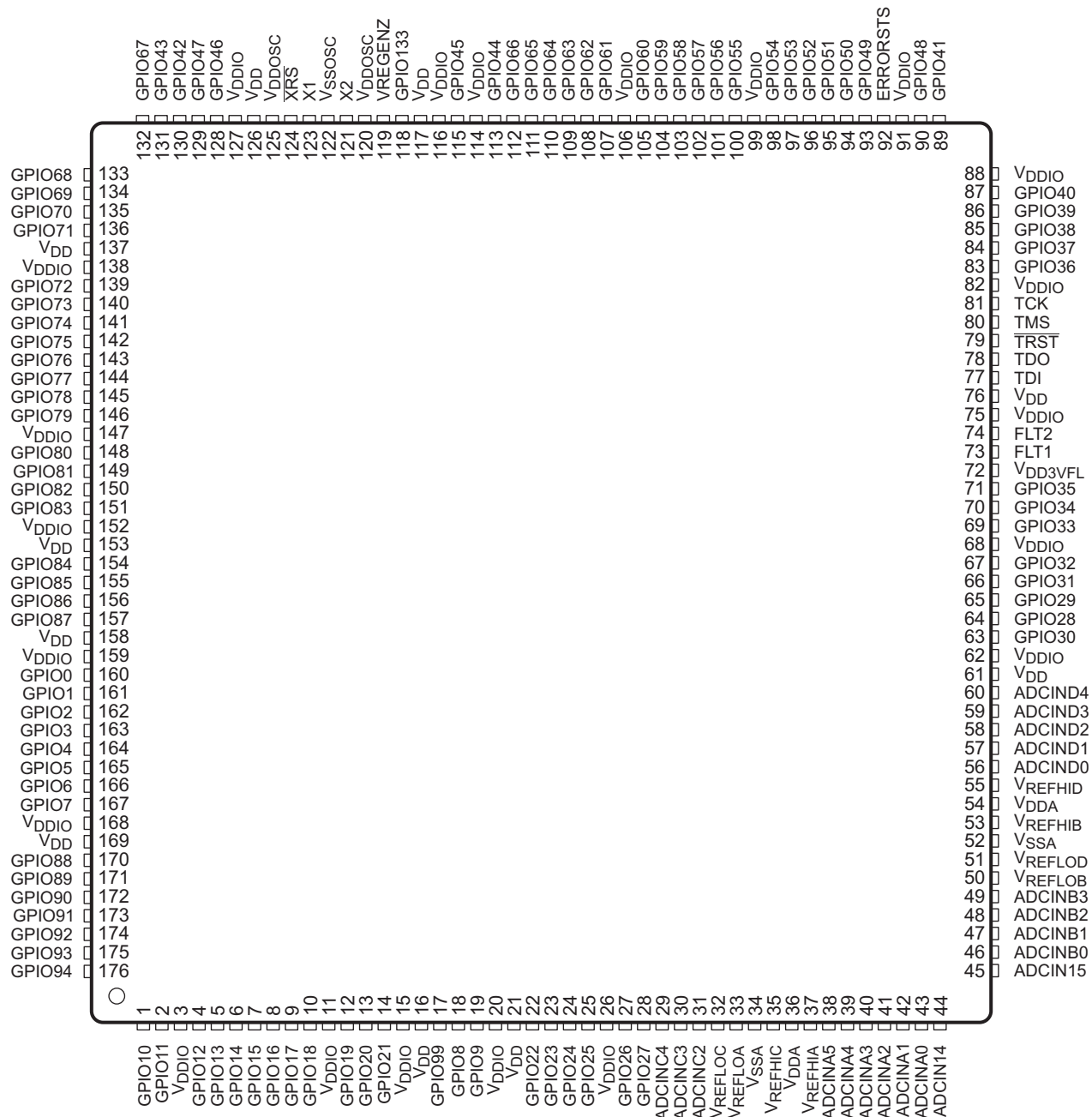

ADVANCE INFORMATION

A. Only the GPIO function is shown on GPIO pins. See Table 4-1 for the complete, muxed signal name.

Figure 4-5. 176-Pin PTP PowerPAD Thermally Enhanced Low-Profile Quad Flatpack (Top View)

4.1 Signal Descriptions

Table 4-1 describes the signals. With the exception of the JTAG pins, the GPIO function is the default at reset, unless otherwise mentioned. The peripheral signals that are listed under them are alternate functions. Some peripheral functions may not be available in all devices. See Table 3-1 for details. All GPIO pins are I/O/Z and have an internal pullup, which can be selectively enabled or disabled on a per-pin basis. This feature only applies to the GPIO pins. The pullups are not enabled at reset.

Table 4-1. Signal Descriptions

TERMINAL			I/O/Z ⁽¹⁾	DESCRIPTION
NAME	ZWT BALL NO.	PTP PIN NO.		
ADC INPUTS AND COMPARATOR INPUTS				
V _{REFHIA}	V1	37	I	ADC-A high reference. Place at least a 1-μF capacitor on this pin, this is required for both internal and external references.
V _{REFHIB}	W5	53	I	ADC-B high reference. Place at least a 1-μF capacitor on this pin, this is required for both internal and external references.
V _{REFHIC}	R1	35	I	ADC-C high reference. Place at least a 1-μF capacitor on this pin, this is required for both internal and external references.
V _{REFHID}	V5	55	I	ADC-D high reference. Place at least a 1-μF capacitor on this pin, this is required for both internal and external references.
V _{REFLOA}	R2	33	I	ADC-A low reference
V _{REFLOB}	V6	50	I	ADC-B low reference
V _{REFLOC}	P2	32	I	ADC-C low reference
V _{REFLOD}	W6	51	I	ADC-D low reference
ADCIN14			I	Input 14 to all ADCs. This pin can be used as a general-purpose ADCIN pin or it can be used to calibrate all ADCs together (either single-ended or differential) from an external reference.
CMPIN4P	T4	44	I	Comparator 4 positive input
ADCIN15			I	Input 15 to all ADCs. This pin can be used as a general-purpose ADCIN pin or it can be used to calibrate all ADCs together (either single-ended or differential) from an external reference.
CMPIN4N	U4	45	I	Comparator 4 negative input
ADCINA0			I	ADC-A input 0
DACOUTA	U1	43	O	DAC-A output ⁽²⁾
ADCINA1			I	ADC-A input 1
DACOUTB	T1	42	O	DAC-B output ⁽²⁾
ADCINA2			I	ADC-A input 2
CMPIN1P	U2	41	I	Comparator 1 positive input
ADCINA3			I	ADC-A input 3
CMPIN1N	T2	40	I	Comparator 1 negative input
ADCINA4			I	ADC-A input 4
CMPIN2P	U3	39	I	Comparator 2 positive input
ADCINA5			I	ADC-A input 5
CMPIN2N	T3	38	I	Comparator 2 negative input
ADCINB0			I	ADC-B input 0
VDAC	V2	46	I	Optional external reference voltage for on-chip DACs
ADCINB1			I	ADC-B input 1
DACOUTC	W2	47	O	DAC-C output ⁽²⁾
ADCINB2			I	ADC-B input 2
CMPIN3P	V3	48	I	Comparator 3 positive input
ADCINB3			I	ADC-B input 3
CMPIN3N	W3	49	I	Comparator 3 negative input

Table 4-1. Signal Descriptions (continued)

TERMINAL			I/O/Z ⁽¹⁾	DESCRIPTION
NAME	ZWT BALL NO.	PTP PIN NO.		
ADCINB4	V4	–	I	ADC-B input 4
ADCINB5	W4	–	I	ADC-B input 5
ADCINC2 CMPIN6P	R3	31	I	ADC-C input 2 Comparator 6 positive input
ADCINC3 CMPIN6N	P3	30	I	ADC-C input 3 Comparator 6 negative input
ADCINC4 CMPIN5P	R4	29	I	ADC-C input 4 Comparator 5 positive input
ADCINC5 CMPIN5N	P4	–	I	ADC-C input 5 Comparator 5 negative input
ADCIND0 CMPIN7P	T5	56	I	ADC-D input 0 Comparator 7 positive input
ADCIND1 CMPIN7N	U5	57	I	ADC-D input 1 Comparator 7 negative input
ADCIND2 CMPIN8P	T6	58	I	ADC-D input 2 Comparator 8 positive input
ADCIND3 CMPIN8N	U6	59	I	ADC-D input 3 Comparator 8 negative input
ADCIND4	T7	60	I	ADC-D input 4
ADCIND5	U7	–	I	ADC-D input 5
GPIO AND PERIPHERAL SIGNALS				
GPIO0 EPWM1A SDAA	C8	160	I/O O I/OD	General-purpose input/output 0 Enhanced PWM1 output A and HRPWM channel I2C-A data open-drain bidirectional port
GPIO1 EPWM1B MFSRB SCLA	D8	161	I/O O I/O I/OD	General-purpose input/output 1 Enhanced PWM1 output B and HRPWM channel McBSP-B receive frame synch I2C-A clock open-drain bidirectional port
GPIO2 EPWM2A OUTPUTXBAR1 SDAB	A7	162	I/O O O I/OD	General-purpose input/output 2 Enhanced PWM2 output A and HRPWM channel Output 1 of the output XBAR I2C-B data open-drain bidirectional port
GPIO3 EPWM2B OUTPUTXBAR2 MCLKRB OUTPUTXBAR2 SCLB	B7	163	I/O O O I/O O I/OD	General-purpose input/output 3 Enhanced PWM2 output B and HRPWM channel Output 2 of the output XBAR McBSP-B receive clock Output 2 of the output XBAR I2C-B clock open-drain bidirectional port
GPIO4 EPWM3A OUTPUTXBAR3 CANTXA	C7	164	I/O O O O	General-purpose input/output 4 Enhanced PWM3 output A and HRPWM channel Output 3 of the output XBAR CAN-A transmit

Table 4-1. Signal Descriptions (continued)

TERMINAL			I/O/Z ⁽¹⁾	DESCRIPTION
NAME	ZWT BALL NO.	PTP PIN NO.		
GPIO5	D7	165	I/O	General-purpose input/output 5
EPWM3B			O	Enhanced PWM3 output B and HRPWM channel
MFSRA			I/O	McBSP-A receive frame synch
OUTPUTXBAR3			O	Output 3 of the output XBAR
CANRXA			I	CAN-A receive
GPIO6	A6	166	I/O	General-purpose input/output 6
EPWM4A			O	Enhanced PWM4 output A and HRPWM channel
OUTPUTXBAR4			O	Output 4 of the output XBAR
EPWMSYNCO			O	External ePWM synch pulse output
EQEP3A			I	Enhanced QEP3 input A
CANTXB			O	CAN-B transmit
GPIO7	B6	167	I/O	General-purpose input/output 7
EPWM4B			O	Enhanced PWM4 output B and HRPWM channel
MCLKRA			I/O	McBSP-A receive clock
OUTPUTXBAR5			O	Output 5 of the output XBAR
EQEP3B			I	Enhanced QEP3 input B
CANRXB			I	CAN-B receive
GPIO8	G2	18	I/O	General-purpose input/output 8
EPWM5A			O	Enhanced PWM5 output A and HRPWM channel
CANTXB			O	CAN-B transmit
ADCSOCAO			O	ADC start-of-conversion A
EQEP3S			I/O	Enhanced QEP3 strobe
SCITXDA			O	SCI-A transmit data
GPIO9	G3	19	I/O	General-purpose input/output 9
EPWM5B			O	Enhanced PWM5 output B and HRPWM channel
SCITXDB			O	SCI-B transmit data
OUTPUTXBAR6			O	Output 6 of the output XBAR
EQEP3I			I/O	Enhanced QEP3 index
SCIRXDA			I	SCI-A receive data
GPIO10	B2	1	I/O	General-purpose input/output 10
EPWM6A			O	Enhanced PWM6 output A and HRPWM channel
CANRXB			I	CAN-B receive
ADCSOCBO			O	ADC start-of-conversion B
EQEP1A			I	Enhanced QEP1 input A
SCITXDB			O	SCI-B transmit data
UPP-WAIT			I/O	Universal parallel port wait. Receiver asserts to request a pause in transfer.
GPIO11	C1	2	I/O	General-purpose input/output 11
EPWM6B			O	Enhanced PWM6 output B and HRPWM channel
SCIRXDB			I	SCI-B receive data
OUTPUTXBAR7			O	Output 7 of the output XBAR
EQEP1B			I	Enhanced QEP1 input B
SCIRXDB			I	SCI-B receive data
UPP-STRT			I/O	Universal parallel port start. Transmitter asserts at start of DMA line.

Table 4-1. Signal Descriptions (continued)

TERMINAL			I/O/Z ⁽¹⁾	DESCRIPTION
NAME	ZWT BALL NO.	PTP PIN NO.		
GPIO12	C2	4	I/O	General-purpose input/output 12
EPWM7A			O	Enhanced PWM7 output A and HRPWM channel
CANTXB			O	CAN-B transmit
MDXB			O	McBSP-B transmit serial data
EQEP1S			I/O	Enhanced QEP1 strobe
SCITXDC			O	SCI-C transmit data
UPP-ENA			I/O	Universal parallel port enable. Transmitter asserts while data bus is active.
GPIO13	D1	5	I/O	General-purpose input/output 13
EPWM7B			O	Enhanced PWM7 output B and HRPWM channel
CANRXB			I	CAN-B receive
MDRB			I	McBSP-B receive serial data
EQEP1I			I/O	Enhanced QEP1 index
SCIRXDC			I	SCI-C receive data
UPP-D7			I/O	Universal parallel port data line 7
GPIO14	D2	6	I/O	General-purpose input/output 14
EPWM8A			O	Enhanced PWM8 output A and HRPWM channel
SCITXDB			O	SCI-B transmit data
MCLKXB			I/O	McBSP-B transmit clock
OUTPUTXBAR3			O	Output 3 of the output XBAR
UPP-D6			I/O	Universal parallel port data line 6
GPIO15	D3	7	I/O	General-purpose input/output 15
EPWM8B			O	Enhanced PWM8 output B and HRPWM channel
SCIRXDB			I	SCI-B receive data
MFSXB			I/O	McBSP-B transmit frame synch
OUTPUTXBAR4			O	Output 4 of the output XBAR
UPP-D5			I/O	Universal parallel port data line 5
GPIO16	E1	8	I/O	General-purpose input/output 16
SPISIMOA			I/O	SPI-A slave in, master out
CANTXB			O	CAN-B transmit
OUTPUTXBAR7			O	Output 7 of the output XBAR
EPWM9A			O	Enhanced PWM9 output A
SD-D1			I	Sigma-Delta channel 1 data input
UPP-D4			I/O	Universal parallel port data line 4
GPIO17	E2	9	I/O	General-purpose input/output 17
SPISOMIA			I/O	SPI-A slave out, master in
CANRXB			I	CAN-B receive
OUTPUTXBAR8			O	Output 8 of the output XBAR
EPWM9B			O	Enhanced PWM9 output B
SD-C1			I	Sigma-Delta channel 1 clock input
UPP-D3			I/O	Universal parallel port data line 3

Table 4-1. Signal Descriptions (continued)

TERMINAL			I/O/Z ⁽¹⁾	DESCRIPTION
NAME	ZWT BALL NO.	PTP PIN NO.		
GPIO18	E3	10	I/O	General-purpose input/output 18
SPICLKA			I/O	SPI-A clock
SCITXDB			O	SCI-B transmit data
CANRXA			I	CAN-A receive
EPWM10A			O	Enhanced PWM10 output A
SD-D2			I	Sigma-Delta channel 2 data input
UPP-D2			I/O	Universal parallel port data line 2
GPIO19	E4	12	I/O	General-purpose input/output 19
SPISTEA			I/O	SPI-A slave transmit enable
SCIRXDB			I	SCI-B receive data
CANTXA			O	CAN-A transmit
EPWM10B			O	Enhanced PWM10 output B
SD-C2			I	Sigma-Delta channel 2 clock input
UPP-D1			I/O	Universal parallel port data line 1
GPIO20	F2	13	I/O	General-purpose input/output 20
EQEP1A			I	Enhanced QEP1 input A
MDXA			O	McBSP-A transmit serial data
CANTXB			O	CAN-B transmit
EPWM11A			O	Enhanced PWM11 output A
SD-D3			I	Sigma-Delta channel 3 data input
UPP-D0			I/O	Universal parallel port data line 0
GPIO21	F3	14	I/O	General-purpose input/output 21
EQEP1B			I	Enhanced QEP1 input B
MDRA			I	McBSP-A receive serial data
CANRXB			I	CAN-B receive
EPWM11B			O	Enhanced PWM11 output B
SD-C3			I	Sigma-Delta channel 3 clock input
UPP-CLK			I/O	Universal parallel port transmit clock
GPIO22	J4	22	I/O	General-purpose input/output 22
EQEP1S			I/O	Enhanced QEP1 strobe
MCLKXA			I/O	McBSP-A transmit clock
SCITXDB			O	SCI-B transmit data
EPWM12A			O	Enhanced PWM12 output A
SPICLKB			I/O	SPI-B clock
SD-D4			I	Sigma-Delta channel 4 data input
GPIO23	K4	23	I/O	General-purpose input/output 23
EQEP1I			I/O	Enhanced QEP1 index
MFSXA			I/O	McBSP-A transmit frame synch
SCIRXDB			I	SCI-B receive data
EPWM12B			O	Enhanced PWM12 output B
SPISTEB			I/O	SPI-B slave transmit enable
SD-C4			I	Sigma-Delta channel 4 clock input

Table 4-1. Signal Descriptions (continued)

TERMINAL			I/O/Z ⁽¹⁾	DESCRIPTION
NAME	ZWT BALL NO.	PTP PIN NO.		
GPIO24	K3	24	I/O	General-purpose input/output 24
OUTPUTXBAR1			O	Output 1 of the output XBAR
EQEP2A			I	Enhanced QEP2 input A
MDXB			O	McBSP-B transmit serial data
SPISIMOB			I/O	SPI-B slave in, master out
SD-D5			I	Sigma-Delta channel 5 data input
GPIO25	K2	25	I/O	General-purpose input/output 25
OUTPUTXBAR2			O	Output 2 of the output XBAR
EQEP2B			I	Enhanced QEP2 input B
MDRB			I	McBSP-B receive serial data
SPISOMIB			I/O	SPI-B slave out, master in
SD-C5			I	Sigma-Delta channel 5 clock input
GPIO26	K1	27	I/O	General-purpose input/output 26
OUTPUTXBAR3			O	Output 3 of the output XBAR
EQEP2I			I/O	Enhanced QEP2 index
MCLKXB			I/O	McBSP-B transmit clock
OUTPUTXBAR3			O	Output 3 of the output XBAR
SPICLKB			I/O	SPI-B clock
SD-D6	I	Sigma-Delta channel 6 data input		
GPIO27	L1	28	I/O	General-purpose input/output 27
OUTPUTXBAR4			O	Output 4 of the output XBAR
EQEP2S			I/O	Enhanced QEP2 strobe
MFSXB			I/O	McBSP-B transmit frame synch
OUTPUTXBAR4			O	Output 4 of the output XBAR
SPISTEB			I/O	SPI-B slave transmit enable
SD-C6	I	Sigma-Delta channel 6 clock input		
GPIO28	V11	64	I/O	General-purpose input/output 28
SCIRXDA			I	SCI-A receive data
EM1CS4			O	External memory interface 1 chip select 4
OUTPUTXBAR5			O	Output 5 of the output XBAR
EQEP3A			I	Enhanced QEP3 input A
SD-D7			I	Sigma-Delta channel 7 data input
GPIO29	W11	65	I/O	General-purpose input/output 29
SCITXDA			O	SCI-A transmit data
EM1SDCKE			O	External memory interface 1 SDRAM clock enable
OUTPUTXBAR6			O	Output 6 of the output XBAR
EQEP3B			I	Enhanced QEP3 input B
SD-C7			I	Sigma-Delta channel 7 clock input
GPIO30	T11	63	I/O	General-purpose input/output 30
CANRXA			I	CAN-A receive
EM1CLK			O	External memory interface 1 clock
OUTPUTXBAR7			O	Output 7 of the output XBAR
EQEP3S			I/O	Enhanced QEP3 strobe
SD-D8			I	Sigma-Delta channel 8 data input

ADVANCE INFORMATION

Table 4-1. Signal Descriptions (continued)

TERMINAL			I/O/Z ⁽¹⁾	DESCRIPTION
NAME	ZWT BALL NO.	PTP PIN NO.		
GPIO31	U11	66	I/O	General-purpose input/output 31
CANTXA			O	CAN-A transmit
$\overline{\text{EM1WE}}$			O	External memory interface1 write enable
OUTPUTXBAR8			O	Output 8 of the output XBAR
EQEP3I			I/O	Enhanced QEP3 index
SD-C8			I	Sigma-Delta channel 8 clock input
GPIO32	U13	67	I/O	General-purpose input/output 32
SDAA			I/OD	I2C-A data open-drain bidirectional port
$\overline{\text{EM1CS0}}$			O	External memory interface 1 chip select 0
GPIO33	T13	69	I/O	General-purpose input/output 33
SCLA			I/OD	I2C-A clock open-drain bidirectional port
EM1RNW			O	External memory interface 1 read not write
GPIO34	U14	70	I/O	General-purpose input/output 34
OUTPUTXBAR1			O	Output 1 of the output XBAR
$\overline{\text{EM1CS2}}$			O	External memory interface 1 chip select 2
SDAB			I/OD	I2C-B data open-drain bidirectional port
GPIO35	T14	71	I/O	General-purpose input/output 35
SCIRXDA			I	SCI-A receive data
$\overline{\text{EM1CS3}}$			O	External memory interface 1 chip select 3
SCLB	I/OD	I2C-B clock open-drain bidirectional port		
GPIO36	V16	83	I/O	General-purpose input/output 36
SCITXDA			O	SCI-A transmit data
EM1WAIT			I	External memory interface 1 Asynchronous SRAM WAIT
CANRXA			I	CAN-A receive
GPIO37	U16	84	I/O	General-purpose input/output 37
OUTPUTXBAR2			O	Output 2 of the output XBAR
$\overline{\text{EM1OE}}$			O	External memory interface 1 output enable
CANTXA			O	CAN-A transmit
GPIO38	T16	85	I/O	General-purpose input/output 38
EM1A0			O	External memory interface 1 address line 0
SCITXDC			O	SCI-C transmit data
CANTXB			O	CAN-B transmit
GPIO39	W17	86	I/O	General-purpose input/output 39
EM1A1			O	External memory interface 1 address line 1
SCIRXDC			I	SCI-C receive data
CANRXB			I	CAN-B receive
GPIO40	V17	87	I/O	General-purpose input/output 40
EM1A2			O	External memory interface 1 address line 2
SDAB			I/OD	I2C-B data open-drain bidirectional port
GPIO41	U17	89	I/O	General-purpose input/output 41
EM1A3			O	External memory interface 1 address line 3
SCLB			I/OD	I2C-B clock open-drain bidirectional port

Table 4-1. Signal Descriptions (continued)

TERMINAL			I/O/Z ⁽¹⁾	DESCRIPTION
NAME	ZWT BALL NO.	PTP PIN NO.		
GPIO42	D19	130	I/O	General-purpose input/output 42
SDAA			I/OD	I2C-A data open-drain bidirectional port
SCITXDA			O	SCI-A transmit data
USB0DM			I/O	USB PHY differential data
GPIO43	C19	131	I/O	General-purpose input/output 43
SCLA			I/OD	I2C-A clock open-drain bidirectional port
SCIRXDA			I	SCI-A receive data
USB0DP			I/O	USB PHY differential data
GPIO44	K18	113	I/O	General-purpose input/output 44
EM1A4			O	External memory interface 1 address line 4
GPIO45	K19	115	I/O	General-purpose input/output 45
EM1A5			O	External memory interface 1 address line 5
GPIO46	E19	128	I/O	General-purpose input/output 46
EM1A6			O	External memory interface 1 address line 6
SCIRXDD			I	SCI-D receive data
GPIO47	E18	129	I/O	General-purpose input/output 47
EM1A7			O	External memory interface 1 address line 7
SCITXDD			O	SCI-D transmit data
GPIO48	R16	90	I/O	General-purpose input/output 48
OUTPUTXBAR3			O	Output 3 of the output XBAR
EM1A8			O	External memory interface 1 address line 8
SCITXDA			O	SCI-A transmit data
SD-D1			I	Sigma-Delta channel 1 data input
GPIO49	R17	93	I/O	General-purpose input/output 49
OUTPUTXBAR4			O	Output 4 of the output XBAR
EM1A9			O	External memory interface 1 address line 9
SCIRXDA			I	SCI-A receive data
SD-C1			I	Sigma-Delta channel 1 clock input
GPIO50	R18	94	I/O	General-purpose input/output 50
EQEP1A			I	Enhanced QEP1 input A
EM1A10			O	External memory interface 1 address line 10
SPISIMOC			I/O	SPI-C slave in, master out
SD-D2			I	Sigma-Delta channel 2 data input
GPIO51	R19	95	I/O	General-purpose input/output 51
EQEP1B			I	Enhanced QEP1 input B
EM1A11			O	External memory interface 1 address line 11
SPISOMIC			I/O	SPI-C slave out, master in
SD-C2			I	Sigma-Delta channel 2 clock input
GPIO52	P16	96	I/O	General-purpose input/output 52
EQEP1S			I/O	Enhanced QEP1 strobe
EM1A12			O	External memory interface 1 address line 12
SPICLK			I/O	SPI-C clock
SD-D3			I	Sigma-Delta channel 3 data input

ADVANCE INFORMATION

Table 4-1. Signal Descriptions (continued)

TERMINAL			I/O/Z ⁽¹⁾	DESCRIPTION
NAME	ZWT BALL NO.	PTP PIN NO.		
GPIO53	P17	97	I/O	General-purpose input/output 53
EQEP11			I/O	Enhanced QEP1 index
EM1D31			I/O	External memory interface 1 data line 31
EM2D15			I/O	External memory interface 2 data line 15
SPISTEC			I/O	SPI-C slave transmit enable
SD-C3			I	Sigma-Delta channel 3 clock input
GPIO54	P18	98	I/O	General-purpose input/output 54
SPISIMOA			I/O	SPI-A slave in, master out
EM1D30			I/O	External memory interface 1 data line 30
EM2D14			I/O	External memory interface 2 data line 14
EQEP2A			I	Enhanced QEP2 input A
SCITXDB			O	SCI-B transmit data
SD-D4	I	Sigma-Delta channel 4 data input		
GPIO55	P19	100	I/O	General-purpose input/output 55
SPISOMIA			I/O	SPI-A slave out, master in
EM1D29			I/O	External memory interface 1 data line 29
EM2D13			I/O	External memory interface 2 data line 13
EQEP2B			I	Enhanced QEP2 input B
SCIRXDB			I	SCI-B receive data
SD-C4	I	Sigma-Delta channel 4 clock input		
GPIO56	N16	101	I/O	General-purpose input/output 56
SPICLKA			I/O	SPI-A clock
EM1D28			I/O	External memory interface 1 data line 28
EM2D12			I/O	External memory interface 2 data line 12
EQEP2S			I/O	Enhanced QEP2 strobe
SCITXDC			O	SCI-C transmit data
SD-D5	I	Sigma-Delta channel 5 data input		
GPIO57	N18	102	I/O	General-purpose input/output 57
SPISTEA			I/O	SPI-A slave transmit enable
EM1D27			I/O	External memory interface 1 data line 27
EM2D11			I/O	External memory interface 2 data line 11
EQEP2I			I/O	Enhanced QEP2 index
SCIRXDC			I	SCI-C receive data
SD-C5	I	Sigma-Delta channel 5 clock input		
GPIO58	N17	103	I/O	General-purpose input/output 58
MCLKRA			I/O	McBSP-A receive clock
EM1D26			I/O	External memory interface 1 data line 26
EM2D10			I/O	External memory interface 2 data line 10
OUTPUTXBAR1			O	Output 1 of the output XBAR
SPICLKB			I/O	SPI-B clock
SD-D6	I	Sigma-Delta channel 6 data input		
SPISIMOA	I/O	SPI-A slave in, master out		

Table 4-1. Signal Descriptions (continued)

TERMINAL			I/O/Z ⁽¹⁾	DESCRIPTION
NAME	ZWT BALL NO.	PTP PIN NO.		
GPIO59	M16	104	I/O	General-purpose input/output 59 ⁽³⁾
MFSRA			I/O	McBSP-A receive frame synch
EM1D25			I/O	External memory interface 1 data line 25
EM2D9			I/O	External memory interface 2 data line 9
OUTPUTXBAR2			O	Output 2 of the output XBAR
SPISTEB			I/O	SPI-B slave transmit enable
SD-C6			I	Sigma-Delta channel 6 clock input
SPISOMIA			I/O	SPI-A slave out, master in
GPIO60	M17	105	I/O	General-purpose input/output 60
MCLKRB			I/O	McBSP-B receive clock
EM1D24			I/O	External memory interface 1 data line 24
EM2D8			I/O	External memory interface 2 data line 8
OUTPUTXBAR3			O	Output 3 of the output XBAR
SPISIMOB			I/O	SPI-B slave in, master out
SD-D7			I	Sigma-Delta channel 7 data input
SPICLKA			I/O	SPI-A clock
GPIO61	L16	107	I/O	General-purpose input/output 61 ⁽³⁾
MFSRB			I/O	McBSP-B receive frame synch
EM1D23			I/O	External memory interface 1 data line 23
EM2D7			I/O	External memory interface 2 data line 7
OUTPUTXBAR4			O	Output 4 of the output XBAR
SPISOMIB			I/O	SPI-B slave out, master in
SD-C7			I	Sigma-Delta channel 7 clock input
SPISTEA			I/O	SPI-A slave transmit enable
GPIO62	J17	108	I/O	General-purpose input/output 62
SCIRXDC			I	SCI-C receive data
EM1D22			I/O	External memory interface 1 data line 22
EM2D6			I/O	External memory interface 2 data line 6
EQEP3A			I	Enhanced QEP3 input A
CANRXA			I	CAN-A receive
SD-D8			I	Sigma-Delta channel 8 data input
GPIO63	J16	109	I/O	General-purpose input/output 63
SCITXDC			O	SCI-C transmit data
EM1D21			I/O	External memory interface 1 data line 21
EM2D5			I/O	External memory interface 2 data line 5
EQEP3B			I	Enhanced QEP3 input B
CANTXA			O	CAN-A transmit
SD-C8			I	Sigma-Delta channel 8 clock input
SPISIMOB			I/O	SPI-B slave in, master out
GPIO64	L17	110	I/O	General-purpose input/output 64 ⁽³⁾
EM1D20			I/O	External memory interface 1 data line 20
EM2D4			I/O	External memory interface 2 data line 4
EQEP3S			I/O	Enhanced QEP3 strobe
SCIRXDA			I	SCI-A receive data
SPISOMIB			I/O	SPI-B slave out, master in

ADVANCE INFORMATION

Table 4-1. Signal Descriptions (continued)

TERMINAL			I/O/Z ⁽¹⁾	DESCRIPTION
NAME	ZWT BALL NO.	PTP PIN NO.		
GPIO65	K16	111	I/O	General-purpose input/output 65
EM1D19			I/O	External memory interface 1 data line 19
EM2D3			I/O	External memory interface 2 data line 3
EQEP3I			I/O	Enhanced QEP3 index
SCITXDA			O	SCI-A transmit data
SPICLKB			I/O	SPI-B clock
GPIO66	K17	112	I/O	General-purpose input/output 66 ⁽³⁾
EM1D18			I/O	External memory interface 1 data line 18
EM2D2			I/O	External memory interface 2 data line 2
SDAB			I/OD	I2C-B data open-drain bidirectional port
SPISTEB			I/O	SPI-B slave transmit enable
GPIO67	B19	132	I/O	General-purpose input/output 67
EM1D17			I/O	External memory interface 1 data line 17
EM2D1			I/O	External memory interface 2 data line 1
GPIO68	C18	133	I/O	General-purpose input/output 68
EM1D16			I/O	External memory interface 1 data line 16
EM2D0			I/O	External memory interface 2 data line 0
GPIO69	B18	134	I/O	General-purpose input/output 69
EM1D15			I/O	External memory interface 1 data line 15
SCLB			I/OD	I2C-B clock open-drain bidirectional port
SPISIMOC			I/O	SPI-C slave in, master out
GPIO70	A17	135	I/O	General-purpose input/output 70 ⁽³⁾
EM1D14			I/O	External memory interface 1 data line 14
CANRXA			I	CAN-A receive
SCITXDB			O	SCI-B transmit data
SPISOMIC			I/O	SPI-C slave out, master in
GPIO71	B17	136	I/O	General-purpose input/output 71
EM1D13			I/O	External memory interface 1 data line 13
CANTXA			O	CAN-A transmit
SCIRXDB			I	SCI-B receive data
SPICLKC			I/O	SPI-C clock
GPIO72	B16	139	I/O	General-purpose input/output 72 ⁽³⁾
EM1D12			I/O	External memory interface 1 data line 12
CANTXB			O	CAN-B transmit
SCITXDC			O	SCI-C transmit data
SPISTEC			I/O	SPI-C slave transmit enable
GPIO73	A16	140	I/O	General-purpose input/output 73
EM1D11			I/O	External memory interface 1 data line 11
XCLKOUT			O/Z	External oscillator output. This pin outputs a divided-down version of the internal PLL system clock. The divide ratio is defined in the XCLKOUTDIVSEL register. Unlike other GPIO pins, the XCLKOUT pin is not placed in high-impedance state during a reset.
CANRXB			I	CAN-B receive
SCIRXDC			I	SCI-C receive

Table 4-1. Signal Descriptions (continued)

TERMINAL			I/O/Z ⁽¹⁾	DESCRIPTION
NAME	ZWT BALL NO.	PTP PIN NO.		
GPIO74 EM1D10	C17	141	I/O I/O	General-purpose input/output 74 External memory interface 1 data line 10
GPIO75 EM1D9	D16	142	I/O I/O	General-purpose input/output 75 External memory interface 1 data line 9
GPIO76 EM1D8 SCITXDD	C16	143	I/O I/O O	General-purpose input/output 76 External memory interface 1 data line 8 SCI-D transmit data
GPIO77 EM1D7 SCIRXDD	A15	144	I/O I/O I	General-purpose input/output 77 External memory interface 1 data line 7 SCI-D receive data
GPIO78 EM1D6 EQEP2A	B15	145	I/O I/O I	General-purpose input/output 78 External memory interface 1 data line 6 Enhanced QEP2 input A
GPIO79 EM1D5 EQEP2B	C15	146	I/O I/O I	General-purpose input/output 79 External memory interface 1 data line 5 Enhanced QEP2 input B
GPIO80 EM1D4 EQEP2S	D15	148	I/O I/O I/O	General-purpose input/output 80 External memory interface 1 data line 4 Enhanced QEP2 strobe
GPIO81 EM1D3 EQEP2I	A14	149	I/O I/O I/O	General-purpose input/output 81 External memory interface 1 data line 3 Enhanced QEP2 index
GPIO82 EM1D2	B14	150	I/O I/O	General-purpose input/output 82 External memory interface 1 data line 2
GPIO83 EM1D1	C14	151	I/O I/O	General-purpose input/output 83 External memory interface 1 data line 1
GPIO84 SCITXDA MDXB MDXA	A11	154	I/O O O O	General-purpose input/output 84 SCI-A transmit data McBSP-B transmit serial data McBSP-A transmit serial data
GPIO85 EM1D0 SCIRXDA MDRB MDRA	B11	155	I/O I/O I I I	General-purpose input/output 85 External memory interface 1 data line 0 SCI-A receive data McBSP-B receive serial data McBSP-A receive serial data
GPIO86 EM1A13 EM1CAS SCITXDB MCLKXB MCLKXA	C11	156	I/O O O O I/O I/O	General-purpose input/output 86 External memory interface 1 address line 13 External memory interface 1 column address strobe SCI-B transmit data McBSP-B transmit clock McBSP-A transmit clock

ADVANCE INFORMATION

Table 4-1. Signal Descriptions (continued)

TERMINAL			I/O/Z ⁽¹⁾	DESCRIPTION
NAME	ZWT BALL NO.	PTP PIN NO.		
GPIO87	D11	157	I/O	General-purpose input/output 87
EM1A14			O	External memory interface 1 address line 14
EM1RAS			O	External memory interface 1 row address strobe
SCIRXDB			I	SCI-B receive data
MFSXB			I/O	McBSP-B transmit frame synch
MFSXA			I/O	McBSP-A transmit frame synch
GPIO88	C6	170	I/O	General-purpose input/output 88
EM1A15			O	External memory interface 1 address line 15
EM1DQM0			O	External memory interface 1 Input/output mask for byte 0
GPIO89	D6	171	I/O	General-purpose input/output 89
EM1A16			O	External memory interface 1 address line 16
EM1DQM1			O	External memory interface 1 Input/output mask for byte 1
SCITXDC			O	SCI-C transmit data
GPIO90	A5	172	I/O	General-purpose input/output 90
EM1A17			O	External memory interface 1 address line 17
EM1DQM2			O	External memory interface 1 Input/output mask for byte 2
SCIRXDC			I	SCI-C receive data
GPIO91	B5	173	I/O	General-purpose input/output 91
EM1A18			O	External memory interface 1 address line 18
EM1DQM3			O	External memory interface 1 Input/output mask for byte 3
SDAA			I/OD	I2C-A data open-drain bidirectional port
GPIO92	A4	174	I/O	General-purpose input/output 92
EM1A19			O	External memory interface 1 address line 19
EM1BA1			O	External memory interface 1 bank address 1
SCLA			I/OD	I2C-A clock open-drain bidirectional port
GPIO93	B4	175	I/O	General-purpose input/output 93
EM1BA0			O	External memory interface 1 bank address 0
SCITXDD			O	SCI-D transmit data
GPIO94	A3	176	I/O	General-purpose input/output 94
SCIRXDD			I	SCI-D receive data
GPIO95	B3	–	I/O	General-purpose input/output 95
GPIO96	C3	–	I/O	General-purpose input/output 96
EM2DQM1			O	External memory interface 2 Input/output mask for byte 1
EQEP1A			I	Enhanced QEP1 input A
GPIO97	A2	–	I/O	General-purpose input/output 97
EM2DQM0			O	External memory interface 2 Input/output mask for byte 0
EQEP1B			I	Enhanced QEP1 input B
GPIO98	F1	–	I/O	General-purpose input/output 98
EM2A0			O	External memory interface 2 address line 0
EQEP1S			I/O	Enhanced QEP1 strobe
GPIO99	G1	17	I/O	General-purpose input/output 99
EM2A1			O	External memory interface 2 address line 1
EQEP1I			I/O	Enhanced QEP1 index

ADVANCE INFORMATION

Table 4-1. Signal Descriptions (continued)

TERMINAL			I/O/Z ⁽¹⁾	DESCRIPTION
NAME	ZWT BALL NO.	PTP PIN NO.		
GPIO100	H1	–	I/O	General-purpose input/output 100
EM2A2			O	External memory interface 2 address line 2
EQEP2A			I	Enhanced QEP2 input A
SPISIMOC			I/O	SPI-C slave in, master out
GPIO101	H2	–	I/O	General-purpose input/output 101
EM2A3			O	External memory interface 2 address line 3
EQEP2B			I	Enhanced QEP2 input B
SPISOMIC			I/O	SPI-C slave out, master in
GPIO102	H3	–	I/O	General-purpose input/output 102
EM2A4			O	External memory interface 2 address line 4
EQEP2S			I/O	Enhanced QEP2 strobe
SPICLK			I/O	SPI-C clock
GPIO103	J1	–	I/O	General-purpose input/output 103
EM2A5			O	External memory interface 2 address line 5
EQEP2I			I/O	Enhanced QEP2 index
SPISTEC			I/O	SPI-C slave transmit enable
GPIO104	J2	–	I/O	General-purpose input/output 104
SDAA			I/OD	I2C-A data open-drain bidirectional port
EM2A6			O	External memory interface 2 address line 6
EQEP3A			I	Enhanced QEP3 input A
SCITXDD			O	SCI-D transmit data
GPIO105	J3	–	I/O	General-purpose input/output 105
SCLA			I/OD	I2C-A clock open-drain bidirectional port
EM2A7			O	External memory interface 2 address line 7
EQEP3B			I	Enhanced QEP3 input B
SCIRXDD			I	SCI-D receive data
GPIO106	L2	–	I/O	General-purpose input/output 106
EM2A8			O	External memory interface 2 address line 8
EQEP3S			I/O	Enhanced QEP3 strobe
SCITXDC			O	SCI-C transmit data
GPIO107	L3	–	I/O	General-purpose input/output 107
EM2A9			O	External memory interface 2 address line 9
EQEP3I			I/O	Enhanced QEP3 index
SCIRXDC			I	SCI-C receive data
GPIO108	L4	–	I/O	General-purpose input/output 108
EM2A10			O	External memory interface 2 address line 10
GPIO109	N2	–	I/O	General-purpose input/output 109
EM2A11			O	External memory interface 2 address line 11
GPIO110	M2	–	I/O	General-purpose input/output 110
GPIO111	M4	–	I/O	General-purpose input/output 111
EM2BA0			O	External memory interface 2 bank address 0
GPIO112	M3	–	I/O	General-purpose input/output 112
EM2BA1			O	External memory interface 2 bank address 1
GPIO113	N4	–	I/O	General-purpose input/output 113
EM2CAS			O	External memory interface 2 column address strobe

ADVANCE INFORMATION

Table 4-1. Signal Descriptions (continued)

TERMINAL			I/O/Z ⁽¹⁾	DESCRIPTION
NAME	ZWT BALL NO.	PTP PIN NO.		
GPIO114	N3	–	I/O	General-purpose input/output 114
EM2RAS			O	External memory interface 2 row address strobe
GPIO115	V12	–	I/O	General-purpose input/output 115
GPIO116	W10	–	I/O	General-purpose input/output 116
GPIO117	U12	–	I/O	General-purpose input/output 117
GPIO118	T12	–	I/O	General-purpose input/output 118
GPIO119	T15	–	I/O	General-purpose input/output 119
EM2RNW			O	External memory interface 2 read not write
GPIO120	U15	–	I/O	General-purpose input/output 120
EM2WE			O	External memory interface 2 write enable
USB0PFLT			I/O	USB external regulator power fault indicator
GPIO121	W16	–	I/O	General-purpose input/output 121
USB0EPEN			I/O	USB external regulator enable
GPIO122	T8	–	I/O	General-purpose input/output 122
SPISIMOC			I/O	SPI-C slave in, master out
SD-D1			I	Sigma-Delta channel 1 data input
GPIO123	U8	–	I/O	General-purpose input/output 123
SPISOMIC			I/O	SPI-C slave out, master in
SD-C1			I	Sigma-Delta channel 1 clock input
GPIO124	V8	–	I/O	General-purpose input/output 124
SPICLK			I/O	SPI-C clock
SD-D2			I	Sigma-Delta channel 2 data input
GPIO125	T9	–	I/O	General-purpose input/output 125
SPISTEC			I/O	SPI-C slave transmit enable
SD-C2			I	Sigma-Delta channel 2 clock input
GPIO126	U9	–	I/O	General-purpose input/output 126
SD-D3			I	Sigma-Delta channel 3 data input
GPIO127	V9	–	I/O	General-purpose input/output 127
SD-C3			I	Sigma-Delta channel 3 clock input
GPIO128	W9	–	I/O	General-purpose input/output 128
SD-D4			I	Sigma-Delta channel 4 data input
GPIO129	T10	–	I/O	General-purpose input/output 129
SD-C4			I	Sigma-Delta channel 4 clock input
GPIO130	U10	–	I/O	General-purpose input/output 130
SD-D5			I	Sigma-Delta channel 5 data input
GPIO131	V10	–	I/O	General-purpose input/output 131
SD-C5			I	Sigma-Delta channel 5 clock input
GPIO132	W18	–	I/O	General-purpose input/output 132
SD-D6			I	Sigma-Delta channel 6 data input
GPIO133/AUXCLKIN	G18	118	I/O	General-purpose input/output 133
SD-C6			I	Sigma-Delta channel 6 clock input
GPIO134	V18	–	I/O	General-purpose input/output 134
SD-D7			I	Sigma-Delta channel 7 data input

Table 4-1. Signal Descriptions (continued)

TERMINAL			I/O/Z ⁽¹⁾	DESCRIPTION
NAME	ZWT BALL NO.	PTP PIN NO.		
GPIO135	U18	–	I/O	General-purpose input/output 135
SCITXDA			O	SCI-A transmit data
SD-C7			I	Sigma-Delta channel 7 clock input
GPIO136	T17	–	I/O	General-purpose input/output 136
SCIRXDA			I	SCI-A receive data
SD-D8			I	Sigma-Delta channel 8 data input
GPIO137	T18	–	I/O	General-purpose input/output 137
SCITXDB			O	SCI-B transmit data
SD-C8			I	Sigma-Delta channel 8 clock input
GPIO138	T19	–	I/O	General-purpose input/output 138
SCIRXDB			I	SCI-B receive data
GPIO139	N19	–	I/O	General-purpose input/output 139
SCIRXDC			I	SCI-C receive data
GPIO140	M19	–	I/O	General-purpose input/output 140
SCITXDC			O	SCI-C transmit data
GPIO141	M18	–	I/O	General-purpose input/output 141
SCIRXDD			I	SCI-D receive data
GPIO142	L19	–	I/O	General-purpose input/output 142
SCITXDD			O	SCI-D transmit data
GPIO143	F18	–	I/O	General-purpose input/output 143
GPIO144	F17	–	I/O	General-purpose input/output 144
GPIO145	E17	–	I/O	General-purpose input/output 145
EPWM1A			O	Enhanced PWM1 output A and HRPWM channel
GPIO146	D18	–	I/O	General-purpose input/output 146
EPWM1B			O	Enhanced PWM1 output B and HRPWM channel
GPIO147	D17	–	I/O	General-purpose input/output 147
EPWM2A			O	Enhanced PWM2 output A and HRPWM channel
GPIO148	D14	–	I/O	General-purpose input/output 148
EPWM2B			O	Enhanced PWM2 output B and HRPWM channel
GPIO149	A13	–	I/O	General-purpose input/output 149
EPWM3A			O	Enhanced PWM3 output A and HRPWM channel
GPIO150	B13	–	I/O	General-purpose input/output 150
EPWM3B			O	Enhanced PWM3 output B and HRPWM channel
GPIO151	C13	–	I/O	General-purpose input/output 151
EPWM4A			O	Enhanced PWM4 output A and HRPWM channel
GPIO152	D13	–	I/O	General-purpose input/output 152
EPWM4B			O	Enhanced PWM4 output B and HRPWM channel
GPIO153	A12	–	I/O	General-purpose input/output 153
EPWM5A			O	Enhanced PWM5 output A and HRPWM channel
GPIO154	B12	–	I/O	General-purpose input/output 154
EPWM5B			O	Enhanced PWM5 output B and HRPWM channel
GPIO155	C12	–	I/O	General-purpose input/output 155
EPWM6A			O	Enhanced PWM6 output A and HRPWM channel
GPIO156	D12	–	I/O	General-purpose input/output 156
EPWM6B			O	Enhanced PWM6 output B and HRPWM channel

Table 4-1. Signal Descriptions (continued)

TERMINAL			I/O/Z ⁽¹⁾	DESCRIPTION
NAME	ZWT BALL NO.	PTP PIN NO.		
GPIO157 EPWM7A	B10	–	I/O O	General-purpose input/output 157 Enhanced PWM7 output A and HRPWM channel
GPIO158 EPWM7B	C10	–	I/O O	General-purpose input/output 158 Enhanced PWM7 output B and HRPWM channel
GPIO159 EPWM8A	D10	–	I/O O	General-purpose input/output 159 Enhanced PWM8 output A and HRPWM channel
GPIO160 EPWM8B	B9	–	I/O O	General-purpose input/output 160 Enhanced PWM8 output B and HRPWM channel
GPIO161 EPWM9A	C9	–	I/O O	General-purpose input/output 161 Enhanced PWM9 output A
GPIO162 EPWM9B	D9	–	I/O O	General-purpose input/output 162 Enhanced PWM9 output B
GPIO163 EPWM10A	A8	–	I/O O	General-purpose input/output 163 Enhanced PWM10 output A
GPIO164 EPWM10B	B8	–	I/O O	General-purpose input/output 164 Enhanced PWM10 output B
GPIO165 EPWM11A	C5	–	I/O O	General-purpose input/output 165 Enhanced PWM11 output A
GPIO166 EPWM11B	D5	–	I/O O	General-purpose input/output 166 Enhanced PWM11 output B
GPIO167 EPWM12A	C4	–	I/O O	General-purpose input/output 167 Enhanced PWM12 output A
GPIO168 EPWM12B	D4	–	I/O O	General-purpose input/output 168 Enhanced PWM12 output B

Table 4-1. Signal Descriptions (continued)

TERMINAL			I/O/Z ⁽¹⁾	DESCRIPTION
NAME	ZWT BALL NO.	PTP PIN NO.		
RESET				
$\overline{\text{XRS}}$	F19	124	I/OD	Device reset (in) and watchdog reset (out). F2837xD devices have built-in power-on reset circuitry. During a power-on condition, this pin is driven low by the device. This pin is also driven low by the MCU when a watchdog or NMI watchdog reset occurs. During watchdog reset, the $\overline{\text{XRS}}$ pin is driven low for 512 INTOSC1 cycles. External circuitry may also drive this pin to assert a device reset. In this case, it is recommended that this pin be driven by an open-drain device. An R-C circuit must be connected to this pin for noise immunity reasons. Regardless of the source, a device reset causes the device to terminate execution. When reset is deactivated, execution begins at the reset vector in the boot ROM. The output buffer of this pin is an open-drain with an internal pullup. This pin has an internal 300-ns (nominal) glitch filter.
CLOCKS				
X1	G19	123	I	On-chip crystal-oscillator input. To use this oscillator, a quartz crystal must be connected across X1 and X2. If this pin is not used, it must be tied to GND. This pin can also be used to feed a single-ended 3.3-V level clock. In this case, X2 is a No Connect (NC).
X2	J19	121	O	On-chip crystal-oscillator output. A quartz crystal may be connected across X1 and X2. If X2 is not used, it must be left unconnected.
NO CONNECT				
NC	H4	–		No connect. BGA ball is electrically open and not connected to the die.
JTAG				
TCK	V15	81	I	JTAG test clock with internal pullup (see Section 5.3)
TDI	W13	77	I	JTAG test data input (TDI) with internal pullup. TDI is clocked into the selected register (instruction or data) on a rising edge of TCK.
TDO	W15	78	O/Z	JTAG scan out, test data output (TDO). The contents of the selected register (instruction or data) are shifted out of TDO on the falling edge of TCK. (6-mA drive). ⁽³⁾
TMS	W14	80	I	JTAG test-mode select (TMS) with internal pullup. This serial control input is clocked into the TAP controller on the rising edge of TCK.
$\overline{\text{TRST}}$	V14	79	I	JTAG test reset with internal pulldown. $\overline{\text{TRST}}$, when driven high, gives the scan system control of the operations of the device. If this signal is not connected or driven low, the device operates in its functional mode, and the test reset signals are ignored. NOTE: $\overline{\text{TRST}}$ is an active-low test pin and must be maintained low at all times during normal device operation. An external pulldown resistor is required on this pin. The value of this resistor should be based on drive strength of the debugger pods applicable to the design. A 2.2-k Ω resistor generally offers adequate protection. Since the value of the resistor is application-specific, TI recommends that each target board be validated for proper operation of the debugger and the application. This pin has an internal 50-ns (nominal) glitch filter.
INTERNAL VOLTAGE REGULATOR CONTROL				
VREGENZ	J18	119	I	Internal voltage regulator enable with internal pulldown. The internal VREG is not supported and must be disabled. Connect VREGENZ to V _{DDIO} .

Table 4-1. Signal Descriptions (continued)

TERMINAL			I/O/Z ⁽¹⁾	DESCRIPTION
NAME	ZWT BALL NO.	PTP PIN NO.		
ANALOG, DIGITAL, AND I/O POWER				
V _{DD}	E9	16		1.2-V digital logic power pins. Place a minimum 422-nF decoupling capacitor on each V _{DD} pin. Higher value capacitors may be used but could impact supply rail ramp-up time.
	E11	21		
	F9	61		
	F11	76		
	G14	117		
	G15	126		
	J14	137		
	J15	153		
	K5	158		
	K6	169		
	P10	–		
	P13	–		
	R10	–		
R13	–			
V _{DD3VFL}	R11	72		3.3-V Flash power pin. Place a minimum 0.1-μF decoupling capacitor on each pin.
	R12	–		
V _{DDA}	P6	36		3.3-V analog power pins. Place a minimum 2.2-μF decoupling capacitor on each pin.
	R6	54		

Table 4-1. Signal Descriptions (continued)

TERMINAL			I/O/Z ⁽¹⁾	DESCRIPTION
NAME	ZWT BALL NO.	PTP PIN NO.		
V _{DDIO}	A9	3		3.3-V digital I/O power pins. Place a minimum 0.1- μ F decoupling capacitor on each pin.
	A18	11		
	B1	15		
	E7	20		
	E10	26		
	E13	62		
	E16	68		
	F4	75		
	F7	82		
	F10	88		
	F13	91		
	F16	99		
	G4	106		
	G5	114		
	G6	116		
	H5	127		
	H6	138		
	L14	147		
	L15	152		
	M1	159		
M5	168			
M6	–			
N14	–			
N15	–			
P9	–			
R9	–			
V19	–			
W8	–			
V _{DDOSC}	H16	120		3.3-V on-chip oscillator power pins. Place a minimum 0.1- μ F decoupling capacitor on each pin.
	H17	125		

ADVANCE INFORMATION

Table 4-1. Signal Descriptions (continued)

TERMINAL			I/O/Z ⁽¹⁾	DESCRIPTION
NAME	ZWT BALL NO.	PTP PIN NO.		
V _{SS}	A1	PWR PAD		Analog and digital ground. For Quad Flatpacks (QFPs), the PowerPad on the bottom of the package must be soldered to the ground plane of the PCB.
	A10			
	A19			
	E5			
	E6			
	E8			
	E12			
	E14			
	E15			
	F5			
	F6			
	F8			
	F12			
	F14			
	F15			
	G16			
	G17			
	H8			
	H9			
	H10			
	H11			
	H12			
	H14			
	H15			
	J5			
	J6			
	J8			
	J9			
	J10			
	J11			
	J12			
	K8			
	K9			
K10				
K11				
K12				
K14				
K15				
L5				
L6				
L8				
L9				

ADVANCE INFORMATION

Table 4-1. Signal Descriptions (continued)

TERMINAL			I/O/Z ⁽¹⁾	DESCRIPTION
NAME	ZWT BALL NO.	PTP PIN NO.		
V _{SS}	L10	PWR PAD		Analog and digital ground power pad (located on the bottom of the chip for quad flatpacks).
	L11			
	L12			
	L18			
	M8			
	M9			
	M10			
	M11			
	M12			
	M14			
	M15			
	N1			
	N5			
	N6			
	P7			
	P8			
	P11			
	P12			
	P14			
	P15			
R7				
R8				
R14				
R15				
W7				
W19				
V _{SSOSC}	H18	122		Clock oscillator ground pin. When using an external crystal, do not connect this pin to the board ground. Instead, connect it to the ground reference of the external crystal oscillator circuit. If an external crystal is not used, this pin may be connected to the board ground.
	H19	–		
V _{SSA}	P1	34		Analog module ground pins
	P5	52		
	R5	–		
	V7	–		
	W1	–		
SPECIAL FUNCTIONS				
ERRORSTS	U19	92	O	Error status output. This pin has pull-down.
TEST PINS				
FLT1	W12	73	I/O	Flash test pin 1. Reserved for TI. Must be left unconnected.
FLT2	V13	74	I/O	Flash test pin 2. Reserved for TI. Must be left unconnected.

(1) I = Input, O = Output, OD = Open Drain, Z = High Impedance

(2) 100 kΩ of pull-down is present on the pin when the DAC output is active; 50 kΩ of pull-down is present on the pin when the DAC output is inactive.

(3) This pin has output impedance that can be as low as 22Ω. This output could have fast edges and ringing depending on the system PCB characteristics. If this is a concern, the user should take precautions such as adding a 39Ω (10% tolerance) series termination resistor or implement some other termination scheme. It is also recommended that a system-level signal integrity analysis be performed with the provided IBIS models. The termination is not required if this pin is used for input function.

4.2 Pin Multiplexing

4.2.1 GPIO Muxed Pins

Table 4-2 shows the GPIO muxed pins and their alternate USB functions. The default for each pin is the GPIO function, secondary functions can be selected by setting both the GPyGMUXn.GPIOz and GPyMUXn.GPIOz register bits. The GPyGMUXn register should be configured prior to the GPyMUXn to avoid transient pulses on GPIO's from alternate mux selections. Columns not shown and blank cells are reserved GPIO Mux settings. The alternate USB function is selected by the GPyAMSEL register.

Table 4-2. GPIO Muxed Pins⁽¹⁾⁽²⁾

GPIO Index	GPIO Mux Selection								Alternate Function
	0, 4, 8, 12	1	2	3	5	6	7	15	N/A
GPyGMUXn. GPIOz =	00b, 01b, 10b, 11b	00b			01b			11b	GPyAMSEL. GPIOz = 1
GPyMUXn. GPIOz =	00b	01b	10b	11b	01b	10b	11b	11b	GPyAMSEL. GPIOz=1
GPIO0	EPWM1A (O)					SDAA (I/OD)			
GPIO1	EPWM1B (O)			MFSRB (I/O)		SCLA (I/OD)			
GPIO2	EPWM2A (O)				OUTPUTXBAR1 (O)	SDAB (I/OD)			
GPIO3	EPWM2B (O)	OUTPUTXBAR2 (O)	MCLKRB (I/O)		OUTPUTXBAR2 (O)	SCLB (I/OD)			
GPIO4	EPWM3A (O)				OUTPUTXBAR3 (O)	CANTXA (O)			
GPIO5	EPWM3B (O)	MFSRA (I/O)		OUTPUTXBAR3 (O)		CANRXA (I)			
GPIO6	EPWM4A (O)	OUTPUTXBAR4 (O)	EPWMSYNCO (O)		EQEP3A (I)	CANTXB (O)			
GPIO7	EPWM4B (O)	MCLKRA (I/O)		OUTPUTXBAR5 (O)	EQEP3B (I)	CANRXB (I)			
GPIO8	EPWM5A (O)	CANTXB (O)	ADCSOAO (O)		EQEP3S (I/O)	SCITXDA (O)			
GPIO9	EPWM5B (O)	SCITXDB (O)		OUTPUTXBAR6 (O)	EQEP3I (I/O)	SCIRXDA (I)			
GPIO10	EPWM6A (O)	CANRXB (I)	ADCSOAO (O)		EQEP1A (I)	SCITXDB (O)		UPP-WAIT (I/O)	
GPIO11	EPWM6B (O)	SCIRXDB (I)		OUTPUTXBAR7 (O)	EQEP1B (I)	SCIRXDB (I)		UPP-STRT (I/O)	
GPIO12	EPWM7A (O)	CANTXB (O)	MDXB (O)		EQEP1S (I/O)	SCITXDC (O)		UPP-ENA (I/O)	
GPIO13	EPWM7B (O)	CANRXB (I)	MDRB (I)		EQEP1I (I/O)	SCIRXDC (I)		UPP-D7 (I/O)	
GPIO14	EPWM8A (O)	SCITXDB (O)		MCLKXB (I/O)		OUTPUTXBAR3 (O)		UPP-D6 (I/O)	
GPIO15	EPWM8B (O)	SCIRXDB (I)		MFSXB (I/O)		OUTPUTXBAR4 (O)		UPP-D5 (I/O)	
GPIO16	SPISIMOA (I/O)	CANTXB (O)		OUTPUTXBAR7 (O)	EPWM9A (O)		SD-D1 (I)	UPP-D4 (I/O)	
GPIO17	SPISOMIA (I/O)	CANRXB (I)		OUTPUTXBAR8 (O)	EPWM9B (O)		SD-C1 (I)	UPP-D3 (I/O)	
GPIO18	SPICLKA (I/O)	SCITXDB (O)		CANRXA (I)	EPWM10A (O)		SD-D2 (I)	UPP-D2 (I/O)	
GPIO19	SPISTEA (I/O)	SCIRXDB (I)		CANTXA (O)	EPWM10B (O)		SD-C2 (I)	UPP-D1 (I/O)	
GPIO20	EQEP1A (I)	MDXA (O)		CANTXB (O)	EPWM11A (O)		SD-D3 (I)	UPP-D0 (I/O)	
GPIO21	EQEP1B (I)	MDRA (I)		CANRXB (I)	EPWM11B (O)		SD-C3 (I)	UPP-CLK (I/O)	
GPIO22	EQEP1S (I/O)	MCLKXA (I/O)		SCITXDB (O)	EPWM12A (O)	SPICLKB (I/O)	SD-D4 (I)		
GPIO23	EQEP1I (I/O)	MFSXA (I/O)		SCIRXDB (I)	EPWM12B (O)	SPISTEB (I/O)	SD-C4 (I)		
GPIO24	OUTPUTXBAR1 (O)	EQEP2A (I)		MDXB (O)		SPISIMOB (I/O)	SD-D5 (I)		
GPIO25	OUTPUTXBAR2 (O)	EQEP2B (I)		MDRB (I)		SPISOMIB (I/O)	SD-C5 (I)		
GPIO26	OUTPUTXBAR3 (O)	EQEP2I (I/O)		MCLKXB (I/O)	OUTPUTXBAR3 (O)	SPICLKB (I/O)	SD-D6 (I)		
GPIO27	OUTPUTXBAR4 (O)	EQEP2S (I/O)		MFSXB (I/O)	OUTPUTXBAR4 (O)	SPISTEB (I/O)	SD-C6 (I)		

(1) I = Input, O = Output, OD = Open Drain

(2) GPIO Index settings of 9, 10, 11, 13, and 14 are reserved.

Table 4-2. GPIO Muxed Pins⁽¹⁾⁽²⁾ (continued)

GPIO Index	GPIO Mux Selection								Alternate Function
	0, 4, 8, 12	1	2	3	5	6	7	15	N/A
GPyGMUXn. GPIOz =	00b, 01b, 10b, 11b	00b			01b			11b	GPyAMSEL. GPIOz = 1
GPyMUXn. GPIOz =	00b	01b	10b	11b	01b	10b	11b	11b	GPyAMSEL. GPIOz=1
GPIO28	SCIRXDA (I)	$\overline{\text{EM1CS4}}$ (O)			OUTPUTXBAR5 (O)	EQEP3A (I)	SD-D7 (I)		
GPIO29	SCITXDA (O)	EM1SDCKE (O)			OUTPUTXBAR6 (O)	EQEP3B (I)	SD-C7 (I)		
GPIO30	CANRXA (I)	EM1CLK (O)			OUTPUTXBAR7 (O)	EQEP3S (I/O)	SD-D8 (I)		
GPIO31	CANTXA (O)	$\overline{\text{EM1WE}}$ (O)			OUTPUTXBAR8 (O)	EQEP3I (I/O)	SD-C8 (I)		
GPIO32	SDAA (I/OD)	$\overline{\text{EM1CS0}}$ (O)							
GPIO33	SCLA (I/OD)	EM1RNW (O)							
GPIO34	OUTPUTXBAR1 (O)	$\overline{\text{EM1CS2}}$ (O)				SDAB (I/OD)			
GPIO35	SCIRXDA (I)	$\overline{\text{EM1CS3}}$ (O)				SCLB (I/OD)			
GPIO36	SCITXDA (O)	EM1WAIT (I)				CANRXA (I)			
GPIO37	OUTPUTXBAR2 (O)	$\overline{\text{EM1OE}}$ (O)				CANTXA (O)			
GPIO38		EM1A0 (O)			SCITXDC (O)	CANTXB (O)			
GPIO39		EM1A1 (O)			SCIRXDC (I)	CANRXB (I)			
GPIO40		EM1A2 (O)				SDAB (I/OD)			
GPIO41		EM1A3 (O)				SCLB (I/OD)			
GPIO42						SDAA (I/OD)		SCITXDA (O)	USB0DM
GPIO43						SCLA (I/OD)		SCIRXDA (I)	USB0DP
GPIO44		EM1A4 (O)							
GPIO45		EM1A5 (O)							
GPIO46		EM1A6 (O)				SCIRXDD (I)			
GPIO47		EM1A7 (O)				SCITXDD (O)			
GPIO48	OUTPUTXBAR3 (O)	EM1A8 (O)				SCITXDA (O)	SD-D1 (I)		
GPIO49	OUTPUTXBAR4 (O)	EM1A9 (O)				SCIRXDA (I)	SD-C1 (I)		
GPIO50	EQEP1A (I)	EM1A10 (O)				SPISIMOC (I/O)	SD-D2 (I)		
GPIO51	EQEP1B (I)	EM1A11 (O)				SPISOMIC (I/O)	SD-C2 (I)		
GPIO52	EQEP1S (I/O)	EM1A12 (O)				SPICLK (I/O)	SD-D3 (I)		
GPIO53	EQEP1I (I/O)	EM1D31 (I/O)	EM2D15 (I/O)			SPISTEC (I/O)	SD-C3 (I)		
GPIO54	SPISIMOA (I/O)	EM1D30 (I/O)	EM2D14 (I/O)	EQEP2A (I)	SCITXDB (O)	SD-D4 (I)			
GPIO55	SPISOMIA (I/O)	EM1D29 (I/O)	EM2D13 (I/O)	EQEP2B (I)	SCIRXDB (I)	SD-C4 (I)			
GPIO56	SPICLKA (I/O)	EM1D28 (I/O)	EM2D12 (I/O)	EQEP2S (I/O)	SCITXDC (O)	SD-D5 (I)			
GPIO57	SPISTEA (I/O)	EM1D27 (I/O)	EM2D11 (I/O)	EQEP2I (I/O)	SCIRXDC (I)	SD-C5 (I)			
GPIO58	MCLKRA (I/O)	EM1D26 (I/O)	EM2D10 (I/O)	OUTPUTXBAR1 (O)	SPICLB (I/O)	SD-D6 (I)	SPISIMOA (I/O)		
GPIO59	MFSRA (I/O)	EM1D25 (I/O)	EM2D9 (I/O)	OUTPUTXBAR2 (O)	SPISTEB (I/O)	SD-C6 (I)	SPISOMIA (I/O)		
GPIO60	MCLKRB (I/O)	EM1D24 (I/O)	EM2D8 (I/O)	OUTPUTXBAR3 (O)	SPISIMOB (I/O)	SD-D7 (I)	SPICLKA (I/O)		
GPIO61	MFSRB (I/O)	EM1D23 (I/O)	EM2D7 (I/O)	OUTPUTXBAR4 (O)	SPISOMIB (I/O)	SD-C7 (I)	SPISTEA (I/O)		
GPIO62	SCIRXDC (I)	EM1D22 (I/O)	EM2D6 (I/O)	EQEP3A (I)	CANRXA (I)	SD-D8 (I)			
GPIO63	SCITXDC (O)	EM1D21 (I/O)	EM2D5 (I/O)	EQEP3B (I)	CANTXA (O)	SD-C8 (I)	SPISIMOB (I/O)		
GPIO64		EM1D20 (I/O)	EM2D4 (I/O)	EQEP3S (I/O)	SCIRXDA (I)		SPISOMIB (I/O)		
GPIO65		EM1D19 (I/O)	EM2D3 (I/O)	EQEP3I (I/O)	SCITXDA (O)		SPICLB (I/O)		
GPIO66		EM1D18 (I/O)	EM2D2 (I/O)		SDAB (I/OD)		SPISTEB (I/O)		
GPIO67		EM1D17 (I/O)	EM2D1 (I/O)						
GPIO68		EM1D16 (I/O)	EM2D0 (I/O)						
GPIO69		EM1D15 (I/O)				SCLB (I/OD)		SPISIMOC (I/O)	
GPIO70		EM1D14 (I/O)			CANRXA (I)	SCITXDB (O)		SPISOMIC (I/O)	
GPIO71		EM1D13 (I/O)			CANTXA (O)	SCIRXDB (I)		SPICLK (I/O)	

Table 4-2. GPIO Muxed Pins⁽¹⁾⁽²⁾ (continued)

GPIO Index	GPIO Mux Selection								Alternate Function
	0, 4, 8, 12	1	2	3	5	6	7	15	N/A
GPyGMUXn. GPIOz =	00b, 01b, 10b, 11b	00b			01b			11b	GPyAMSEL. GPIOz = 1
GPyMUXn. GPIOz =	00b	01b	10b	11b	01b	10b	11b	11b	GPyAMSEL. GPIOz=1
GPIO72			EM1D12 (I/O)		CANTXB (O)	SCITXDC (O)		SPISTEC (I/O)	
GPIO73			EM1D11 (I/O)	XCLKOUT (O)	CANRXB (I)	SCIRXDC (I)			
GPIO74			EM1D10 (I/O)						
GPIO75			EM1D9 (I/O)						
GPIO76			EM1D8 (I/O)			SCITXDD (O)			
GPIO77			EM1D7 (I/O)			SCIRXDD (I)			
GPIO78			EM1D6 (I/O)			EQEP2A (I)			
GPIO79			EM1D5 (I/O)			EQEP2B (I)			
GPIO80			EM1D4 (I/O)			EQEP2S (I/O)			
GPIO81			EM1D3 (I/O)			EQEP2I (I/O)			
GPIO82			EM1D2 (I/O)						
GPIO83			EM1D1 (I/O)						
GPIO84					SCITXDA (O)	MDXB (O)		MDXA (O)	
GPIO85			EM1D0 (I/O)		SCIRXDA (I)	MDRB (I)		MDRA (I)	
GPIO86			EM1A13 (O)	EM1CAS (O)	SCITXDB (O)	MCLKXB (I/O)		MCLKXA (I/O)	
GPIO87			EM1A14 (O)	EM1RAS (O)	SCIRXDB (I)	MFSXB (I/O)		MFSXA (I/O)	
GPIO88			EM1A15 (O)	EM1DQM0 (O)					
GPIO89			EM1A16 (O)	EM1DQM1 (O)		SCITXDC (O)			
GPIO90			EM1A17 (O)	EM1DQM2 (O)		SCIRXDC (I)			
GPIO91			EM1A18 (O)	EM1DQM3 (O)		SDAA (I/OD)			
GPIO92			EM1A19 (O)	EM1BA1 (O)		SCLA (I/OD)			
GPIO93				EM1BA0 (O)		SCITXDD (O)			
GPIO94						SCIRXDD (I)			
GPIO95									
GPIO96				EM2DQM1 (O)	EQEP1A (I)				
GPIO97				EM2DQM0 (O)	EQEP1B (I)				
GPIO98				EM2A0 (O)	EQEP1S (I/O)				
GPIO99				EM2A1 (O)	EQEP1I (I/O)				
GPIO100				EM2A2 (O)	EQEP2A (I)	SPISIMOC (I/O)			
GPIO101				EM2A3 (O)	EQEP2B (I)	SPISOMIC (I/O)			
GPIO102				EM2A4 (O)	EQEP2S (I/O)	SPICLK (I/O)			
GPIO103				EM2A5 (O)	EQEP2I (I/O)	SPISTEC (I/O)			
GPIO104		SDAA (I/OD)		EM2A6 (O)	EQEP3A (I)	SCITXDD (O)			
GPIO105		SCLA (I/OD)		EM2A7 (O)	EQEP3B (I)	SCIRXDD (I)			
GPIO106				EM2A8 (O)	EQEP3S (I/O)	SCITXDC (O)			
GPIO107				EM2A9 (O)	EQEP3I (I/O)	SCIRXDC (I)			
GPIO108				EM2A10 (O)					
GPIO109				EM2A11 (O)					
GPIO110									
GPIO111				EM2BA0 (O)					
GPIO112				EM2BA1 (O)					
GPIO113				EM2CAS (O)					
GPIO114				EM2RAS (O)					
GPIO115									
GPIO116									
GPIO117									
GPIO118									
GPIO119				EM2RNW (O)					
GPIO120				EM2WE (O)				USB0PFLT	
GPIO121								USB0EPEN	
GPIO122						SPISIMOC (I/O)	SD-D1 (I)		

ADVANCE INFORMATION

Table 4-2. GPIO Muxed Pins⁽¹⁾⁽²⁾ (continued)

GPIO Index	GPIO Mux Selection								Alternate Function
	0, 4, 8, 12	1	2	3	5	6	7	15	N/A
GPyGMUXn. GPIOz =	00b, 01b, 10b, 11b	00b			01b			11b	GPyAMSEL. GPIOz = 1
GPyMUXn. GPIOz =	00b	01b	10b	11b	01b	10b	11b	11b	GPyAMSEL. GPIOz=1
GPIO123						SPISOMIC (I/O)	SD-C1 (I)		
GPIO124						SPICLK (I/O)	SD-D2 (I)		
GPIO125						SPISTEC (I/O)	SD-C2 (I)		
GPIO126							SD-D3 (I)		
GPIO127							SD-C3 (I)		
GPIO128							SD-D4 (I)		
GPIO129							SD-C4 (I)		
GPIO130							SD-D5 (I)		
GPIO131							SD-C5 (I)		
GPIO132							SD-D6 (I)		
GPIO133/ AUXCLKIN							SD-C6 (I)		
GPIO134							SD-D7 (I)		
GPIO135						SCITXDA (O)	SD-C7 (I)		
GPIO136						SCIRXDA (I)	SD-D8 (I)		
GPIO137						SCITXDB (O)	SD-C8 (I)		
GPIO138						SCIRXDB (I)			
GPIO139						SCIRXDC (I)			
GPIO140						SCITXDC (O)			
GPIO141						SCIRXDD (I)			
GPIO142						SCITXDD (O)			
GPIO143									
GPIO144									
GPIO145		EPWM1A (O)							
GPIO146		EPWM1B (O)							
GPIO147		EPWM2A (O)							
GPIO148		EPWM2B (O)							
GPIO149		EPWM3A (O)							
GPIO150		EPWM3B (O)							
GPIO151		EPWM4A (O)							
GPIO152		EPWM4B (O)							
GPIO153		EPWM5A (O)							
GPIO154		EPWM5B (O)							
GPIO155		EPWM6A (O)							
GPIO156		EPWM6B (O)							
GPIO157		EPWM7A (O)							
GPIO158		EPWM7B (O)							
GPIO159		EPWM8A (O)							
GPIO160		EPWM8B (O)							
GPIO161		EPWM9A (O)							
GPIO162		EPWM9B (O)							
GPIO163		EPWM10A (O)							
GPIO164		EPWM10B (O)							
GPIO165		EPWM11A (O)							
GPIO166		EPWM11B (O)							
GPIO167		EPWM12A (O)							
GPIO168		EPWM12B (O)							

ADVANCE INFORMATION

5 Specifications

5.1 Absolute Maximum Ratings^{(1) (2)}

Supply voltage range, V_{DDIO}	with respect to V_{SS}	-0.3 V to 4.6 V
Supply voltage range, V_{DDSFL}	with respect to V_{SS}	-0.3 V to 4.6 V
Supply voltage range, V_{DDOSC}	with respect to V_{SS}	-0.3 V to 4.6 V
Supply voltage range, V_{DD}	with respect to V_{SS}	-0.3 V to 1.5 V
Analog voltage range, V_{DDA}	with respect to V_{SSA}	-0.3 V to 4.6 V
Supply ramp rate (V_{DDIO} , V_{DD} , V_{DDA} , V_{DDSFL} , V_{DDOSC})	with respect to V_{SS}	$< 10^5$ V/s
Input voltage range, V_{IN} (3.3 V)		-0.3 V to 4.6 V
Output voltage range, V_O		-0.3 V to 4.6 V
Input clamp current, I_{IK} ($V_{IN} < 0$ or $V_{IN} > V_{DDIO}$) ⁽³⁾		± 20 mA
Output clamp current, I_{OK} ($V_O < 0$ or $V_O > V_{DDIO}$)		± 20 mA
Free-Air temperature, T_A		-40°C to 125°C

(1) Stresses beyond those listed under Absolute Maximum Ratings may cause permanent damage to the device. These are stress ratings only, and functional operation of the device at these or any other conditions beyond those indicated under Section 5.2 is not implied. Exposure to conditions with absolute maximum ratings for extended periods may affect device reliability.

(2) All voltage values are with respect to V_{SS} , unless otherwise noted.

(3) Continuous clamp current per pin is ± 2 mA.

5.2 Recommended Operating Conditions

		MIN	NOM	MAX	UNIT
Device supply voltage, I/O, V_{DDIO} ⁽¹⁾		3.14	3.3	3.47	V
Device supply voltage, V_{DD}		1.14	1.2	1.26	V
Supply ground, V_{SS}			0		V
Analog supply voltage, V_{DDA} ⁽¹⁾		3.14	3.3	3.47	V
Analog ground, V_{SSA}			0		V
Device clock frequency (system clock)			2	200	MHz
Free-Air temperature, T_A	T version	-40		105	°C
	S version	-40		125	
	Q version (Q100 qualification)	-40		125	

(1) V_{DDIO} , V_{DDSFL} , V_{DDOSC} , and V_{DDA} should be maintained within approximately 0.3 V of each other.

5.3 Electrical Characteristics

over recommended operating conditions (unless otherwise noted)

PARAMETER		TEST CONDITIONS	MIN	TYP	MAX	UNIT
V _{OH}	High-level output voltage	I _{OH} = I _{OH} MAX	V _{DDIO} * 0.8			V
		I _{OH} = 50 μA	V _{DDIO} – 0.2			
V _{OL}	Low-level output voltage	I _{OL} = I _{OL} MAX	V _{DDIO} * 0.2			V
I _{OH}	High-level output source current for all GPIO pins	V _{OH} = V _{OH(MIN)}	–4			mA
I _{OL}	Low-level output sink current for all GPIO pins	V _{OL} = V _{OL(MAX)}	4			mA
I _{OZ}	Output current, pullup or pulldown disabled	V _O = V _{DDIO} or 0 V	±2			μA
V _{IH}	High-level input voltage (3.3 V)		V _{DDIO} * 0.7	V _{DDIO} + 0.3		V
V _{IL}	Low-level input voltage (3.3 V)		V _{SS} – 0.3	V _{DDIO} * 0.3		V
I _{IH}	Input current on pins with pulldown enabled	V _{DDIO} = 3.3 V, V _{IN} = V _{DDIO}	120			μA
I _{IL}	Input current on pins with pullup enabled	V _{DDIO} = 3.3 V, V _{IN} = 0 V	–150			μA
C _I	Input capacitance		2			pF

5.4 Handling Ratings

		MIN	MAX	UNIT
T _{stg}	Storage temperature range ⁽¹⁾	–65	150	°C
V _{ESD} ⁽²⁾	Human Body Model (HBM) ESD Stress Voltage ⁽³⁾	–2	2	kV
	Charged Device Model (CDM) ESD Stress Voltage ⁽⁴⁾	–500	500	V

- (1) Long-term high-temperature storage or extended use at maximum temperature conditions may result in a reduction of overall device life. For additional information, see *IC Package Thermal Metrics Application Report* (literature number [SPRA953](#)).
- (2) Electrostatic discharge (ESD) to measure device sensitivity/immunity to damage caused by assembly line electrostatic discharges into the device.
- (3) Level listed is the passing level per ANSI/ESDA/JEDEC JS-001. JEDEC document JEP155 states that 500-V HBM allows safe manufacturing with a standard ESD control process, and manufacturing with less than 500-V HBM is possible if necessary precautions are taken. Pins listed as 1000 V may actually have higher performance.
- (4) Level listed is the passing level per EIA-JEDEC JESD22-C101E. JEDEC document JEP157 states that 250-V CDM allows safe manufacturing with a standard ESD control process, and manufacturing with less than 250-V CDM is possible if necessary precautions are taken. Pins listed as 250 V may actually have higher performance.

5.5 Timing and Switching Characteristics

5.5.1 Flash Timing

Table 5-1. Flash/OTP Access Timing for CPU1 Subsystem and CPU2 Subsystem⁽¹⁾

PARAMETER		MIN	MAX	UNIT
$t_{a(f)}$	Flash access time	20		ns
$t_{a(OTP)}$	TI OTP access time	40		ns
$t_{a(UOTP)}$	User configurable DCSM OTP access time	220		ns

(1) Access time values shown in [Table 5-1](#) are prior to device characterization. Final values will be published in this data manual when the device becomes a fully qualified production device.

Table 5-2. Minimum Required Flash/OTP Wait-States at Different Frequencies for CPU1 Subsystem and CPU2 Subsystem

CPUCLK (MHz)	CPUCLK (ns)	WAIT-STATE
200	5	3
190	5.26	3
180	5.56	3
170	5.88	3
160	6.25	3
150	6.7	2
140	7.14	2
130	7.7	2
120	8.33	2
110	9.1	2
100	10	1
90	11.11	1
80	12.5	1
70	14.29	1
60	16.67	1
50	20	0
40	25	0
30	33.33	0
20	50	0
10	100	0

The equation to compute Flash wait-state in [Table 5-2](#) is as follows:

$$R_{WAIT} = \left[\left(\frac{SYSCLK (MHz)}{50 MHz} \right) - 1 \right] \text{ round up to the next integer, or 1, whichever is larger}$$

5.5.2 ADC Electrical Data and Timing

Table 5-3. ADC Characteristics (16-Bit Mode)

over recommended operating conditions (unless otherwise noted)

PARAMETER	TEST CONDITIONS	MIN	TYP	MAX	UNIT
Input clock		1		50	MHz
Sample window duration		320			ns
ADC conversion cycles			29.5		ADCCLKs
Conversion range		V_{REFLO}		V_{REFHI}	V
V_{REFHI}		1.98	2.5	V_{DDA}	V
V_{REFLO}			0		V
Gain error			± 64		LSB
Offset error ⁽¹⁾	$T_J = 30^\circ\text{C}$		± 1		mV
Offset error drift ⁽¹⁾			± 0.01		mV/°C
DNL			± 0.5		LSB
INL			± 1.5		LSB
Channel-to-channel offset error			± 2		LSB
Common mode voltage ⁽²⁾		$V_{REFCM} - 50$		$V_{REFCM} + 50$	mV

(1) Relative to 2.5-V V_{REFHI}/V_{REFLO} range.

(2) $V_{REFCM} = (V_{REFHI} + V_{REFLO})/2$
Table 5-4. ADC Characteristics (12-Bit Mode)

over recommended operating conditions (unless otherwise noted)

PARAMETER	TEST CONDITIONS	MIN	TYP	MAX	UNIT
Input clock		1		50	MHz
Sample window duration		75			ns
ADC conversion cycles			10.5		ADCCLKs
Conversion range		V_{REFLO}		V_{REFHI}	V
V_{REFHI}		1.98	3.3	V_{DDA}	V
V_{REFLO}			0		V
Gain error			± 4		LSB
Offset error			± 4		LSB
DNL			± 0.5		LSB
INL			± 1.5		LSB
Channel-to-channel offset error			± 2		LSB
Common mode voltage ⁽¹⁾		$V_{REFCM} - 50$		$V_{REFCM} + 50$	mV

(1) $V_{REFCM} = (V_{REFHI} + V_{REFLO})/2$

5.5.3 Temperature Sensor Electrical Data and Timing

Table 5-5. Temperature Sensor Electrical Characteristics

over recommended operating conditions (unless otherwise noted)

PARAMETER	TEST CONDITIONS	MIN	TYP	MAX	UNIT
Temperature accuracy			± 15		°C
Startup time			500		μs

5.5.4 Buffered DAC Electrical Data and Timing

Table 5-6. Buffered DAC Electrical Characteristics

over recommended operating conditions (unless otherwise noted)

PARAMETER	TEST CONDITIONS	MIN	TYP	MAX	UNIT
Power supply rejection	1 Hz		70		dB
Noise			500		μV
Untrimmed offset	End point corrected		±40		mV
Gain error			±2.5		% of FSR
DNL			±0.4		LSB
INL	End point corrected		±2		LSB
Voltage output settling time			2		μs
Resolution			12		Bit
Output range			0.6 to ($V_{REF} - 0.6$)		V
Maximum capacitive load			100		pF
Minimum resistive load			5		kΩ
R_{PD}	DAC enabled		100		kΩ
	DAC disabled		50		

5.5.5 CMPSS Electrical Data and Timing

Table 5-7. Comparator Electrical Characteristics

over recommended operating conditions (unless otherwise noted)

PARAMETER	TEST CONDITIONS	MIN	TYP	MAX	UNIT
Comparator input referred offset			±20		mV
Comparator hysteresis values			7		mV

Table 5-8. Comparator/DAC Electrical Characteristics

over recommended operating conditions (unless otherwise noted)

PARAMETER	TEST CONDITIONS	MIN	TYP	MAX	UNIT
DAC offset			1		mV
DAC gain error			-1		%
DAC static INL			±16		LSB
DAC resolution			12		Bit

5.6 Power Sequencing

The voltage on V_{DDIO} should be greater than or equal to the voltage on V_{DD} during power up. Before powering the device, no voltage larger than 0.3 V above V_{DDIO} should be applied to any digital pin, and no voltage larger than 0.3 V above V_{DDA} should be applied to any analog pin. The internal power-on-reset circuit will ensure glitchless IOs during power up.

5.7 Current Consumption

Table 5-9. Typical Current Consumption at 200 MHz

MODE	TEST CONDITIONS ^{(1) (2)}	I _{DD}	I _{DDIO} ⁽³⁾	I _{DDA}	I _{DD3VFL}
Operational (RAM)	The following peripherals are exercised: <ul style="list-style-type: none"> • ePWM1 to ePWM12 • eCAP1 to eCAP6 • CAN-A, CAN-B • SPI-A to SPI-C • SCI-A to SCI-D • I²C-A, I²C-B • McBSP-A • USB • ADC-A to ADC-D • DAC-A to DAC-C • CMPSS1 to CMPSS8 • uPP • CPU1.CLA1, CPU2.CLA1 • CPU1.DMA, CPU2.DMA • CPU1.TIMER0, CPU1.TIMER1, CPU1.TIMER2 • CPU2.TIMER0, CPU2.TIMER1, CPU2.TIMER2 • CPU2.FPU • CPU2.TMU • CPU2.VCU • EMIF-2 	335 mA	70 mA	25 mA	35 mA
IDLE	<ul style="list-style-type: none"> • Both CPU1 and CPU2 are in IDLE mode. • Flash is enabled. • All peripheral clocks are enabled. • XCLKOUT is turned off. 	240 mA	10 mA	150 μA	35 mA
STANDBY	<ul style="list-style-type: none"> • Both CPU1 and CPU2 are in STANDBY mode. • Flash is enabled. • All peripheral clocks are gated. • XCLKOUT is turned off. 	55 mA	10 mA	150 μA	35 mA
HALT ⁽⁴⁾	<ul style="list-style-type: none"> • CPU1 watchdog is running. • XCLKOUT is turned off. 	20 mA	1 mA	150 μA	35 mA
HIBERNATE ⁽⁵⁾	<ul style="list-style-type: none"> • CPU1.M0 and CPU1.M1 RAMs are in low-power data retention mode. • CPU2.M0 and CPU2.M1 RAMs are in low-power data retention mode. 	1 mA	1 mA	140 μA	10 μA

- (1) The following is done in a loop on CPU1:
- Code is running out of RAM.
 - All I/O pins are left unconnected.
 - All of the communication peripherals are exercised in loop-back mode.
 - ePWM1–ePWM12 generate 400-kHz PWM output on 24 pins.
 - CPU1.DMA does 32-bit burst transfers.
 - CPU1.CLA1 does multiply-accumulate tasks.
 - ADC performs continuous conversion.
 - DAC ramps voltage up/down at 150 kHz.
 - FLASH is continuously read and in active state.
 - XCLKOUT is enabled.
- (2) The following is done in a loop on CPU2:
- CPU2.CLA1 does multiply-accumulate tasks.
 - CPU2.VCU does complex multiply/accumulate with parallel load.
 - CPU2.TMU calculates a cosine.
 - CPU2.FPU does multiply/accumulate with parallel load.
- (3) I_{DDIO} current is dependent on the electrical loading on the I/O pins.
- (4) CPU2 must go into IDLE mode before CPU1 enters HALT mode.
- (5) CPU2 must go into reset/IDLE/STANDBY mode before CPU1 enters HIBERNATE mode.

NOTE

The peripheral-I/O multiplexing implemented in the device prevents all available peripherals from being used at the same time because more than one peripheral function may share an I/O pin. Although not useful, it is possible to turn on all peripheral clocks even when the peripheral is not used in the application. If the clocks to all the peripherals are turned on at the same time, the current drawn by the device will be more than the numbers specified in the current consumption table.

5.8 Clocking

5.8.1 Clock Sources

Table 5-10 lists four possible clock sources on the F2837xD device.

Table 5-10. Possible Reference Clock Sources on F2837xD Device

CLOCK SOURCE	POSSIBLE CLOCK SOURCES	COMMENTS
INTOSC1 ⁽¹⁾	Can be used to provide clock for: <ul style="list-style-type: none"> • watchdog block • system clock • CPU-Timer 2 	Internal oscillator 1. Zero-pin overhead 10-MHz internal oscillator.
INTOSC2 ⁽¹⁾⁽²⁾	Can be used to provide clock for: <ul style="list-style-type: none"> • auxiliary clock • system clock • CPU-Timer 2 	Internal oscillator 2. Zero-pin overhead 10-MHz internal oscillator.
XTAL ⁽¹⁾	Can be used to provide clock for: <ul style="list-style-type: none"> • auxiliary clock • system clock • CPU-Timer 2 	External oscillator connected between X1 and X2 pins. On-chip crystal oscillator enables the use of external crystal/resonator to provide time base when connected to the device.
GPIO_AUXCLKIN	Can be used to provide clock for: <ul style="list-style-type: none"> • auxiliary clock • CPU-Timer 2 	Single-ended 3.3-V level clock source. GPIO133/AUXCLKIN pin should be used to provide the input clock.

(1) For power savings, both zero pin internal oscillators and XTAL can be individually powered down if they are not being used by the application.

(2) On reset, internal oscillator 2 (INTOSC2) is the default clock source for both system PLL (OSCCLK) and auxiliary PLL (AUXOSCCLK).

Figure 5-1 shows the clocking options for system PLL.

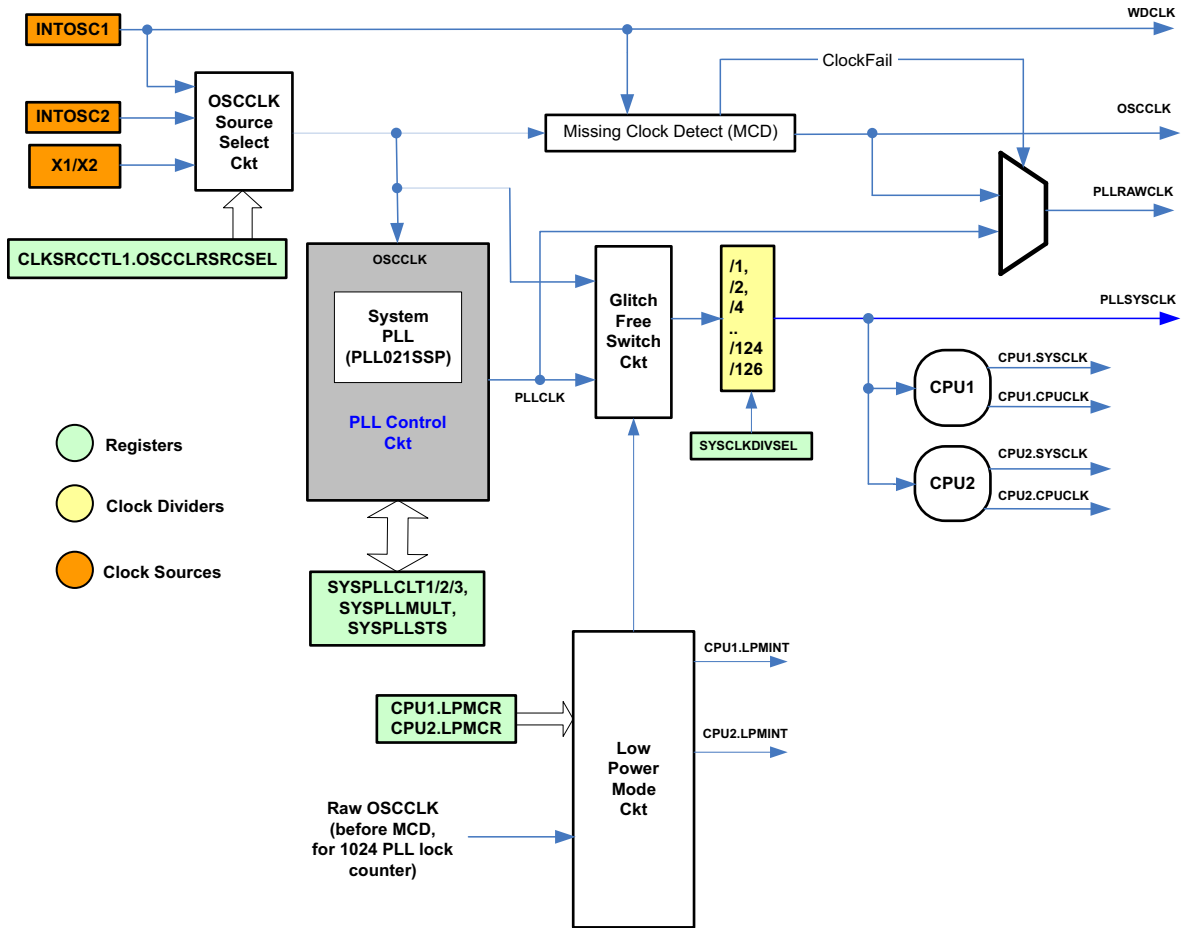

Figure 5-1. Clocking Options for System PLL

NOTE

The clock name for peripheral clocking "PERx.SYSCLK" is used interchangeably with "SYSCLKOUT" in the device documentation.

Figure 5-2 shows the clocking options for auxiliary PLL.

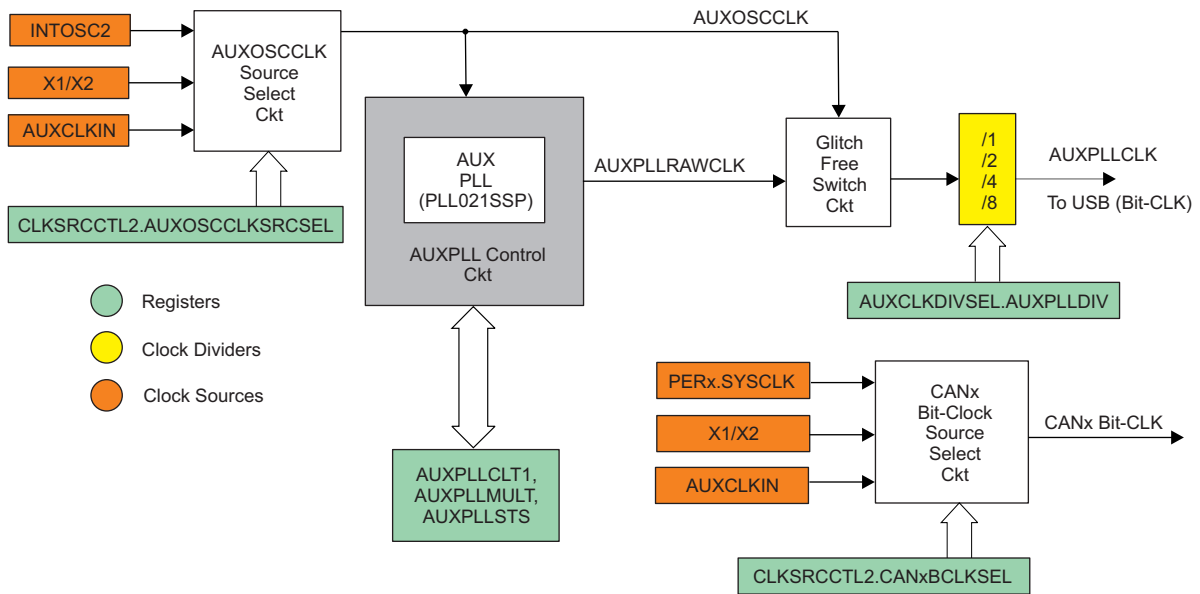

Figure 5-2. Clocking Options for Auxiliary PLL

Figure 5-3 shows the peripheral clock options.

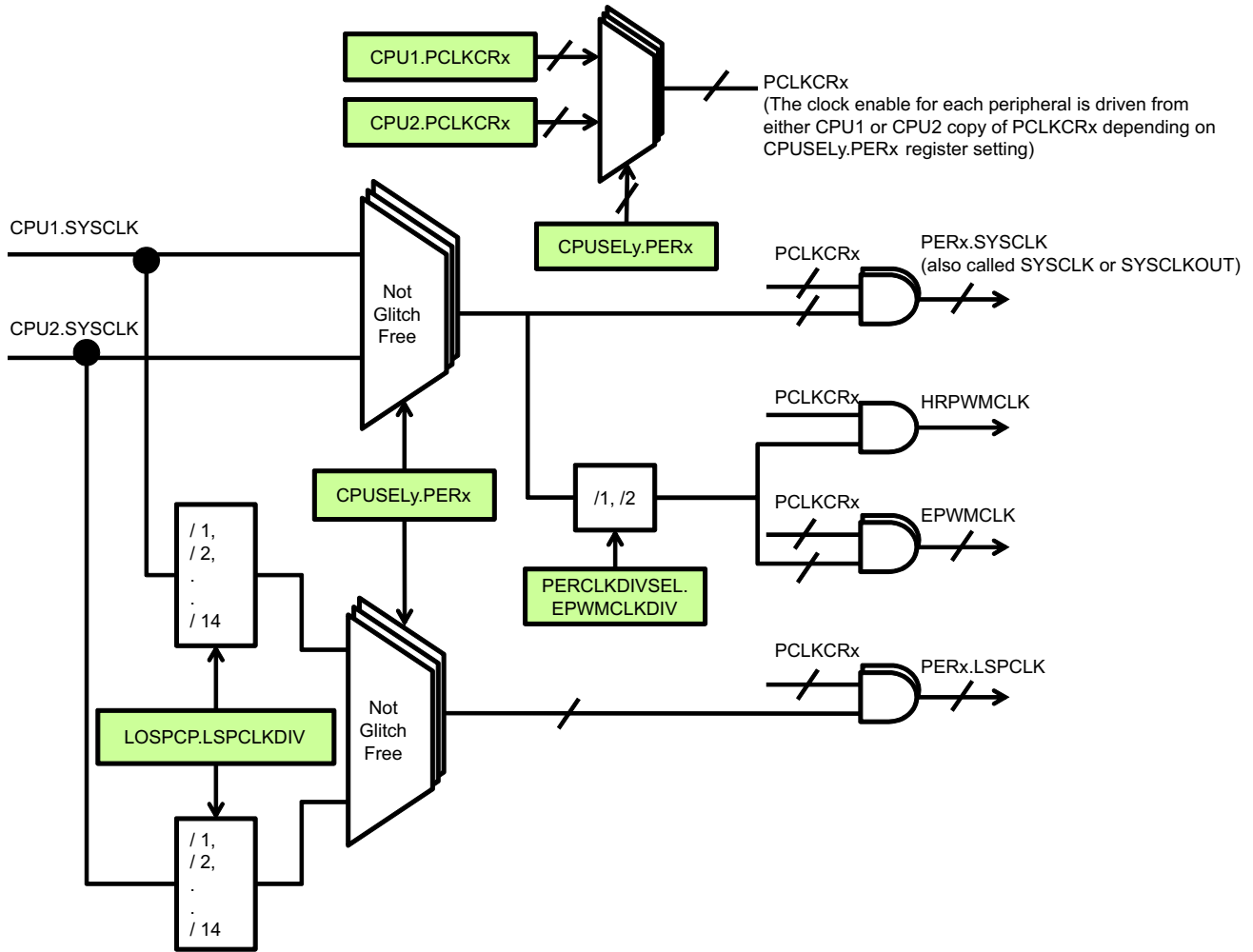

Figure 5-3. Peripheral Clock Options

ADVANCE INFORMATION

Figure 5-4 shows the CPU Timer2 clock options.

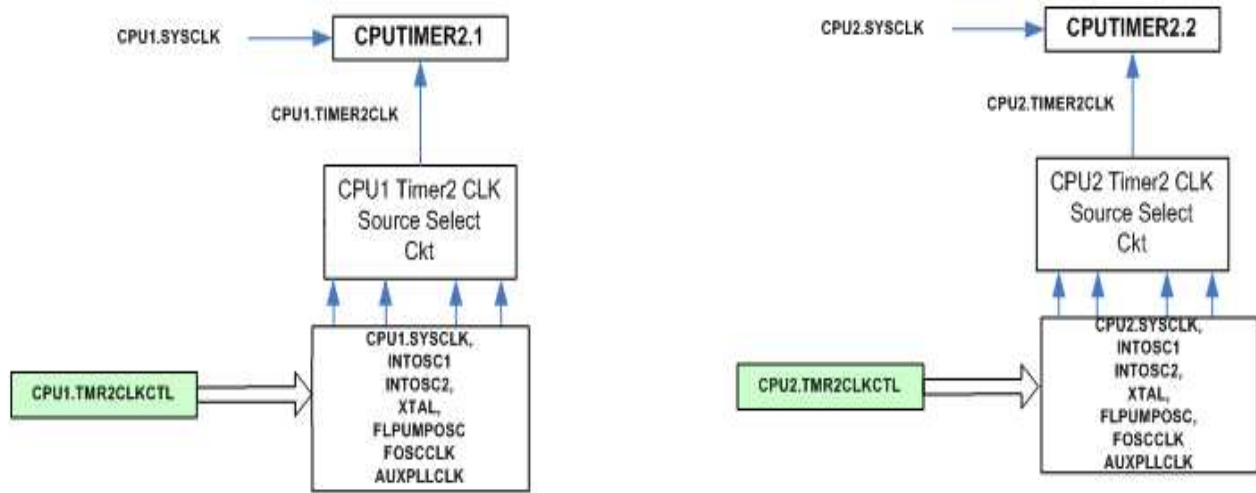

Figure 5-4. CPU Timer2 Clock Options

5.8.2 Clock Frequencies, Requirements, and Characteristics

This section provides the frequencies and timing requirements of the input clocks, PLL lock times, frequencies of the internal clocks, and the frequency and switching characteristics of the output clock.

5.8.2.1 Input Clock Frequency and Timing Requirements, PLL Lock Times

Table 5-11 shows the frequency requirements for the input clocks to the F2837xD devices. Table 5-12 shows the crystal equivalent series resistance requirements. Table 5-13 and Table 5-14 show the timing requirements for the input clocks to the F2837xD devices. Table 5-15 shows the PLL lock times for the Main PLL and the USB PLL.

Table 5-11. Input Clock Frequency

		MIN	MAX	UNIT
$f_{(OSC)}$	Frequency, X1/X2, from external crystal or resonator	2	20	MHz
$f_{(OCI)}$	Frequency, X1, from external oscillator (PLL enabled)	2	30	MHz
$f_{(OCI)}$	Frequency, X1, from external oscillator (PLL disabled)	2	100	MHz
$f_{(XCI)}$	Frequency, XCLKIN, from external oscillator	2	60	MHz

Table 5-12. Crystal Equivalent Series Resistance (ESR) Requirements⁽¹⁾

CRYSTAL FREQUENCY (MHz)	MAXIMUM ESR (Ω) (CL1/2 = 12 pF)	MAXIMUM ESR (Ω) (CL1/2 = 24 pF)
2	175	375
4	100	195
6	75	145
8	65	120
10	55	110
12	50	95
14	50	90
16	45	75
18	45	65
20	45	50

(1) Crystal shunt capacitance (C0) should be less than or equal to 7 pF.

Table 5-13. X1 Timing Requirements

		MIN	MAX	UNIT
$t_{f(OCI)}$	Fall time, X1		6	ns
$t_{r(OCI)}$	Rise time, X1		6	ns
$t_{w(OCL)}$	Pulse duration, X1 low as a percentage of $t_{c(OCI)}$	45	55	%
$t_{w(OCH)}$	Pulse duration, X1 high as a percentage of $t_{c(OCI)}$	45	55	%

Table 5-14. AUXCLKIN Timing Requirements

		MIN	MAX	UNIT
$t_{f(XCI)}$	Fall time, AUXCLKIN		6	ns
$t_{r(XCI)}$	Rise time, AUXCLKIN		6	ns
$t_{w(XCL)}$	Pulse duration, AUXCLKIN low as a percentage of $t_{c(XCI)}$	45	55	%
$t_{w(XCH)}$	Pulse duration, AUXCLKIN high as a percentage of $t_{c(XCI)}$	45	55	%

Table 5-15. PLL Lock Times

		MIN	NOM	MAX	UNIT
$t_{(PLL)}$	Lock time, Main PLL (X1, from external oscillator)		2000 ⁽¹⁾		input clock cycles
$t_{(USB)}$	Lock time, USB PLL (XCLKIN, from external oscillator)		2000 ⁽¹⁾		input clock cycles

(1) For example, if the input clock to the PLL is 10 MHz, then the PLL lock time is 100 ns x 2000 = 200 μ s.

5.8.2.2 Internal Clock Frequencies

Table 5-16 provides the clock frequencies for the internal clocks of the F2837xD devices.

Table 5-16. Internal Clock Frequencies

		MIN	NOM	MAX	UNIT
$f_{(AUX)}$	Frequency, AUXPLLCLK		60		MHz
$f_{(PLL)}$	Frequency, PLLSYSCLK	2		200	MHz
$f_{(OCK)}$	Frequency, OSCCLK	2		100	MHz
$f_{(LSP)}$	Frequency, LSPCLK ⁽¹⁾	2	50 ⁽²⁾	200	MHz
$f_{(INT)}$	Frequency, INTOSC1/2CLK		10		MHz
$f_{(EPWM)}$	Frequency, EPWMCLK			100	MHz

(1) Lower LSPCLK will reduce device power consumption.

(2) This is the default reset value if PLLSYSCLK = 200 MHz.

5.8.2.3 Output Clock Frequency and Switching Characteristics

Table 5-17 provides the frequency of the output clock from the F2837xD devices. Table 5-18 shows the switching characteristics of the output clock from the F2837xD devices, XCLKOUT.

Table 5-17. Output Clock Frequency

		MIN	MAX	UNIT
$f_{(XCO)}$	Frequency, XCLKOUT	2	50	MHz

Table 5-18. XCLKOUT Switching Characteristics (PLL Bypassed or Enabled)⁽¹⁾⁽²⁾

over recommended operating conditions (unless otherwise noted)

	PARAMETER	MIN	MAX	UNIT
$t_{f(XCO)}$	Fall time, XCLKOUT		5	ns
$t_{r(XCO)}$	Rise time, XCLKOUT		5	ns
$t_{w(XCOL)}$	Pulse duration, XCLKOUT low	H – 2	H + 2	ns
$t_{w(XCOH)}$	Pulse duration, XCLKOUT high	H – 2	H + 2	ns

(1) A load of 40 pF is assumed for these parameters.

(2) $H = 0.5t_{c(XCO)}$

5.8.3 Input Clocks and PLLs

F2837xD devices have multiple input clock pins from which all internal clocks and the output clock are derived. Figure 5-5 shows the recommended methods of connecting crystals, resonators, and oscillators to pins X1/X2 and XCLKIN.

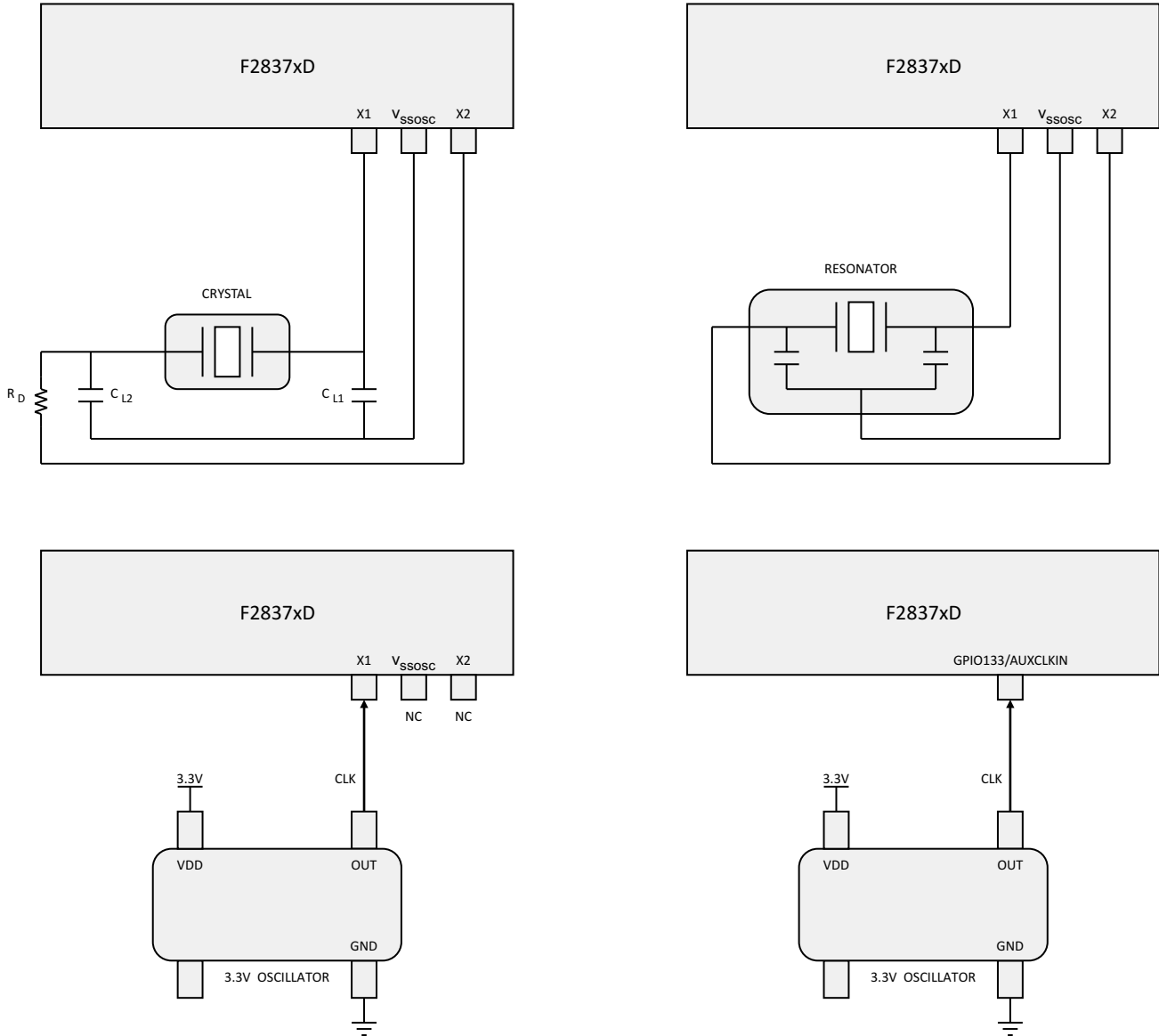

Figure 5-5. Connecting Input Clocks to a F2837xD Device

ADVANCE INFORMATION

5.8.4 Oscillators

Table 5-19. Internal Oscillator Electrical Characteristics

over recommended operating conditions (unless otherwise noted)

PARAMETER	TEST CONDITIONS	MIN	TYP	MAX	UNIT
Nominal frequency			10		MHz
Frequency accuracy	T _J = 30°C		0.1		%
Drift of frequency across temperature and voltage			±3		%
Startup and settling time			22		µs

6 Detailed Description

6.1 Functional Block Diagram

[Figure 6-1](#) shows the CPU system and associated peripherals comprising the TMS320F2837xD device.

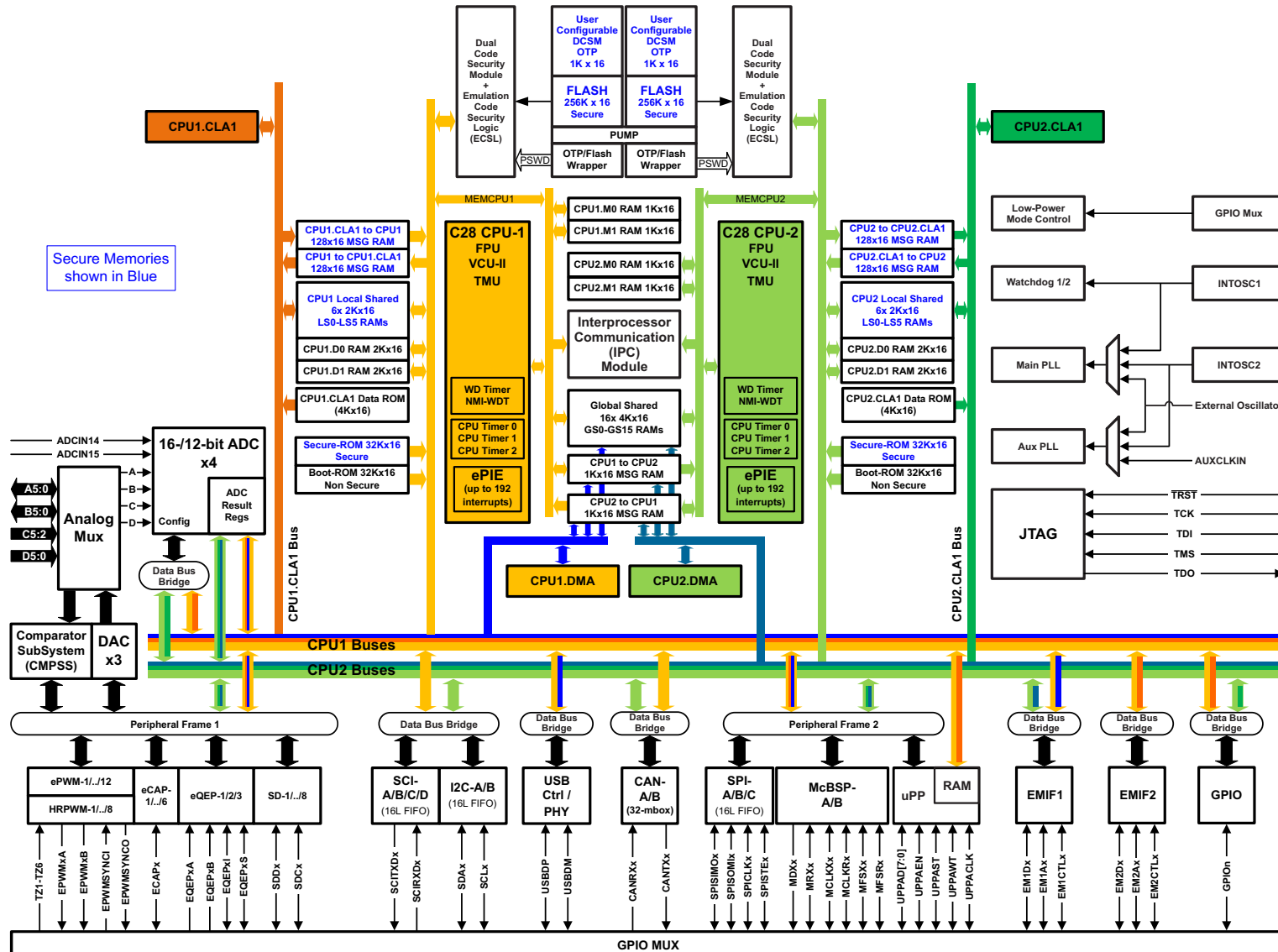

Figure 6-1. Functional Block Diagram

ADVANCE INFORMATION

6.2 Memory Maps

6.2.1 RAM Memory Map

Both C28x CPUs on the F2837xD devices have the same memory map except where noted in [Table 6-1](#). Note the GSx_RAM (Global Shared RAM) should be assigned to either CPU by the GSxMSEL register. Memories accessible by the CLA or DMA (direct memory access) are noted as well.

Table 6-1. RAM Memory Map

RAM	SIZE	START ADDRESS	END ADDRESS	CLA ACCESS	DMA ACCESS
M0_RAM	1K x 16	0x0000 0000	0x0000 03FF		
M1_RAM	1K x 16	0x0000 0400	0x0000 07FF		
PieVectTable	512 x 16	0x0000 0D00	0x0000 0EFF		
CPU1.CLA1toCPU1_MSG_RAM	128 x 16	0x0000 1480	0x0000 14FF	Yes	
CPU1toCPU1.CLA1_MSG_RAM	128 x 16	0x0000 1500	0x0000 157F	Yes	
UPP_TX_MSG_RAM	512 x 16	0x0000 6C00	0x0000 6DFF	Yes	
UPP_RX_MSG_RAM	512 x 16	0x0000 6E00	0x0000 6FFF	Yes	
LS0_RAM	2K x 16	0x0000 8000	0x0000 87FF	Yes	
LS1_RAM	2K x 16	0x0000 8800	0x0000 8FFF	Yes	
LS2_RAM	2K x 16	0x0000 9000	0x0000 97FF	Yes	
LS3_RAM	2K x 16	0x0000 9800	0x0000 9FFF	Yes	
LS4_RAM	2K x 16	0x0000 A000	0x0000 A7FF	Yes	
LS5_RAM	2K x 16	0x0000 A800	0x0000 AFFF	Yes	
D0_RAM	2K x 16	0x0000 B000	0x0000 B7FF		
D1_RAM	2K x 16	0x0000 B800	0x0000 BFFF		
GS0_RAM ⁽¹⁾	4K x 16	0x0000 C000	0x0000 CFFF		Yes
GS1_RAM ⁽¹⁾	4K x 16	0x0000 D000	0x0000 DFFF		Yes
GS2_RAM ⁽¹⁾	4K x 16	0x0000 E000	0x0000 EFFF		Yes
GS3_RAM ⁽¹⁾	4K x 16	0x0000 F000	0x0000 FFFF		Yes
GS4_RAM ⁽¹⁾	4K x 16	0x0001 0000	0x0001 0FFF		Yes
GS5_RAM ⁽¹⁾	4K x 16	0x0001 1000	0x0001 1FFF		Yes
GS6_RAM ⁽¹⁾	4K x 16	0x0001 2000	0x0001 2FFF		Yes
GS7_RAM ⁽¹⁾	4K x 16	0x0001 3000	0x0001 3FFF		Yes
GS8_RAM ⁽¹⁾	4K x 16	0x0001 4000	0x0001 4FFF		Yes
GS9_RAM ⁽¹⁾	4K x 16	0x0001 5000	0x0001 5FFF		Yes
GS10_RAM ⁽¹⁾	4K x 16	0x0001 6000	0x0001 6FFF		Yes
GS11_RAM ⁽¹⁾	4K x 16	0x0001 7000	0x0001 7FFF		Yes
GS12_RAM ⁽¹⁾⁽²⁾	4K x 16	0x0001 8000	0x0001 8FFF		Yes
GS13_RAM ⁽¹⁾⁽²⁾	4K x 16	0x0001 9000	0x0001 9FFF		Yes
GS14_RAM ⁽¹⁾⁽²⁾	4K x 16	0x0001 A000	0x0001 AFFF		Yes
GS15_RAM ⁽¹⁾⁽²⁾	4K x 16	0x0001 B000	0x0001 BFFF		Yes
CPU2_to_CPU1_Message_RAM ⁽¹⁾	1K x 16	0x0003 F800	0x0003 FBFF		Yes
CPU1_to_CPU2_Message_RAM ⁽¹⁾	1K x 16	0x0003 FC00	0x0003 FFFF		Yes
USB_RAM ⁽³⁾	2K x 16	0x0004 1000	0x0004 17FF		Yes
CAN_A_Message_RAM ⁽¹⁾	2K x 16	0x0004 8800	0x0004 97FF		
CAN_B_Message_RAM ⁽¹⁾	2K x 16	0x0004 A800	0x0004 B7FF		
Flash	256K x 16	0x0008 0000	0x000B FFFF		
Secure_ROM	32K x 16	0x003F 0000	0x003F 7FFF		
Boot_ROM	32K x 16	0x003F 8000	0x003F FFBD		
Vectors	64	0x003F FFBE	0x003F FFFF		

(1) Shared between CPU subsystems.

(2) Only available on F28377D and F28375D.

(3) Only on the CPU1 subsystem.

6.2.2 Flash Memory Map

On the F28377D and F28375D devices, each CPU has its own flash bank (256KW), the total flash for each device is 512KW. Only one bank can be programmed or erased at a time and the code to program the flash should be executed out of RAM. [Table 6-2](#) shows the addresses of flash sectors on CPU1 and CPU2 for F28377D and F28375D.

Table 6-2. Addresses of Flash Sectors on CPU1 and CPU2 for F28377D and F28375D

SECTOR	SIZE	START ADDRESS	END ADDRESS
TI OTP	1K x 16	0x07 0000	0x07 03FF
User configurable DCSM OTP	1K x 16	0x07 8000	0x07 83FF
Sector A	8K x 16	0x08 0000	0x08 1FFF
Sector B	8K x 16	0x08 2000	0x08 3FFF
Sector C	8K x 16	0x08 4000	0x08 5FFF
Sector D	8K x 16	0x08 6000	0x08 7FFF
Sector E	32K x 16	0x08 8000	0x08 FFFF
Sector F	32K x 16	0x09 0000	0x09 7FFF
Sector G	32K x 16	0x09 8000	0x09 FFFF
Sector H	32K x 16	0x0A 0000	0x0A 7FFF
Sector I	32K x 16	0x0A 8000	0x0A FFFF
Sector J	32K x 16	0x0B 0000	0x0B 7FFF
Sector K	8K x 16	0x0B 8000	0x0B 9FFF
Sector L	8K x 16	0x0B A000	0x0B BFFF
Sector M	8K x 16	0x0B C000	0x0B DFFF
Sector N	8K x 16	0x0B E000	0x0B FFFF

On the F28376D and F28374D devices, each CPU has its own flash bank (128KW), the total flash for each device is 256KW. Only one bank can be programmed or erased at a time and the code to program the flash should be executed out of RAM. [Table 6-3](#) shows the addresses of flash sectors on CPU1 and CPU2 for F28376D and F28374D.

Table 6-3. Addresses of Flash Sectors on CPU1 and CPU2 for F28376D and F28374D

SECTOR	SIZE	START ADDRESS	END ADDRESS
TI OTP	1K x 16	0x07 0000	0x07 03FF
User configurable DCSM OTP	1K x 16	0x07 8000	0x07 83FF
Sector A	8K x 16	0x08 0000	0x08 1FFF
Sector B	8K x 16	0x08 2000	0x08 3FFF
Sector C	8K x 16	0x08 4000	0x08 5FFF
Sector D	8K x 16	0x08 6000	0x08 7FFF
Sector E	32K x 16	0x08 8000	0x08 FFFF
Sector F	32K x 16	0x09 0000	0x09 7FFF
Sector G	32K x 16	0x09 8000	0x09 FFFF

6.2.3 EMIF Chip Select Memory Map

The EMIF1 memory map is the same for both CPU subsystems. EMIF2 is only available on the CPU1 subsystem.

Table 6-4. EMIF Chip Select Memory Map

EMIF CHIP SELECT	SIZE	START ADDRESS	END ADDRESS	CLA ACCESS	DMA ACCESS
EMIF1_CS0n - Data	256M x 16	0x8000 0000	0x8FFF FFFF		Yes
EMIF1_CS2n - Program + Data	2M x 16	0x0010 0000	0x002F FFFF		Yes
EMIF1_CS3n - Program + Data	512K x 16	0x0030 0000	0x0037 FFFF		Yes
EMIF1_CS4n - Program + Data	393K x 16	0x0038 0000	0x003D FFFF		Yes
EMIF2_CS0n - Data ⁽¹⁾	256M x 16	0x9000 0000	0x9FFF FFFF		
EMIF2_CS2n - Program + Data ⁽¹⁾	4K x 16	0x0000 2000	0x0000 2FFF	Yes (Data only)	

(1) Only available on the CPU1 subsystem.

6.2.4 Peripheral Registers Memory Map

The peripheral registers can be assigned to either the CPU1 or CPU2 subsystems except where noted in [Table 6-5](#). Registers in the peripheral frames share a secondary master (CLA or DMA) selection with all other registers within the same peripheral frame. See the *TMS320F2837xD Delfino Microcontrollers Technical Reference Manual* (literature number [SPRUHM8](#)) for details on the CPU subsystem and secondary master selection.

Table 6-5. Peripheral Registers Memory Map

REGISTERS	STRUCTURE NAME	START ADDRESS	END ADDRESS	CLA ACCESS	DMA ACCESS
AdcaResultRegs	ADC_RESULT_REGS	0x0000 0B00	0x0000 0B1F	Yes	Yes
AdcbResultRegs	ADC_RESULT_REGS	0x0000 0B20	0x0000 0B3F	Yes	Yes
AdccResultRegs	ADC_RESULT_REGS	0x0000 0B40	0x0000 0B5F	Yes	Yes
AdcdResultRegs	ADC_RESULT_REGS	0x0000 0B60	0x0000 0B7F	Yes	Yes
CpuTimer0Regs ⁽¹⁾	CPU_TIMER_REGS	0x0000 0C00	0x0000 3C07		
CpuTimer1Regs ⁽¹⁾	CPU_TIMER_REGS	0x0000 0C08	0x0000 5C0F		
CpuTimer2Regs ⁽¹⁾	CPU_TIMER_REGS	0x0000 0C10	0x0000 C17F		
PieCtrlRegs ⁽¹⁾	PIE_CTRL_REGS	0x0000 0CE0	0x0000 0CFF		
DmaRegs ⁽¹⁾	DMA_REGS	0x0000 1000	0x0000 11FF		
Cla1Regs ⁽¹⁾	CLA_REGS	0x0000 1400	0x0000 147F		
Peripheral Frame 1					
EPwm1Regs	EPWM_REGS	0x0000 4000	0x0000 40FF	Yes	Yes
EPwm2Regs	EPWM_REGS	0x0000 4100	0x0000 41FF	Yes	Yes
EPwm3Regs	EPWM_REGS	0x0000 4200	0x0000 42FF	Yes	Yes
EPwm4Regs	EPWM_REGS	0x0000 4300	0x0000 43FF	Yes	Yes
EPwm5Regs	EPWM_REGS	0x0000 4400	0x0000 44FF	Yes	Yes
EPwm6Regs	EPWM_REGS	0x0000 4500	0x0000 45FF	Yes	Yes
EPwm7Regs	EPWM_REGS	0x0000 4600	0x0000 46FF	Yes	Yes
EPwm8Regs	EPWM_REGS	0x0000 4700	0x0000 47FF	Yes	Yes
EPwm9Regs	EPWM_REGS	0x0000 4800	0x0000 48FF	Yes	Yes
EPwm10Regs	EPWM_REGS	0x0000 4900	0x0000 49FF	Yes	Yes
EPwm11Regs	EPWM_REGS	0x0000 4A00	0x0000 4AFF	Yes	Yes
EPwm12Regs	EPWM_REGS	0x0000 4B00	0x0000 4BFF	Yes	Yes
ECap1Regs	ECAP_REGS	0x0000 5000	0x0000 501F	Yes	Yes
ECap2Regs	ECAP_REGS	0x0000 5020	0x0000 503F	Yes	Yes
ECap3Regs	ECAP_REGS	0x0000 5040	0x0000 505F	Yes	Yes

Table 6-5. Peripheral Registers Memory Map (continued)

REGISTERS	STRUCTURE NAME	START ADDRESS	END ADDRESS	CLA ACCESS	DMA ACCESS
ECap4Regs	ECAP_REGS	0x0000 5060	0x0000 507F	Yes	Yes
ECap5Regs	ECAP_REGS	0x0000 5080	0x0000 509F	Yes	Yes
ECap6Regs	ECAP_REGS	0x0000 50A0	0x0000 50BF	Yes	Yes
ECap7Regs	ECAP_REGS	0x0000 50C0	0x0000 50DF	Yes	Yes
ECap8Regs	ECAP_REGS	0x0000 50E0	0x0000 50FF	Yes	Yes
EQep1Regs	EQEP_REGS	0x0000 5100	0x0000 513F	Yes	Yes
EQep2Regs	EQEP_REGS	0x0000 5140	0x0000 517F	Yes	Yes
EQep3Regs	EQEP_REGS	0x0000 5180	0x0000 51BF	Yes	Yes
DacaRegs	DAC_REGS	0x0000 5C00	0x0000 5C0F	Yes	Yes
DacbRegs	DAC_REGS	0x0000 5C10	0x0000 5C1F	Yes	Yes
DaccRegs	DAC_REGS	0x0000 5C20	0x0000 5C2F	Yes	Yes
Cmpss1Regs	CMPSS_REGS	0x0000 5C80	0x0000 5C9F	Yes	Yes
Cmpss2Regs	CMPSS_REGS	0x0000 5CA0	0x0000 5CBF	Yes	Yes
Cmpss3Regs	CMPSS_REGS	0x0000 5CC0	0x0000 5CDF	Yes	Yes
Cmpss4Regs	CMPSS_REGS	0x0000 5CE0	0x0000 5CFF	Yes	Yes
Cmpss5Regs	CMPSS_REGS	0x0000 5D00	0x0000 5D1F	Yes	Yes
Cmpss6Regs	CMPSS_REGS	0x0000 5D20	0x0000 5D3F	Yes	Yes
Cmpss7Regs	CMPSS_REGS	0x0000 5D40	0x0000 5D5F	Yes	Yes
Cmpss8Regs	CMPSS_REGS	0x0000 5D60	0x0000 5D7F	Yes	Yes
Sdfm1Regs	SDFM_REGS	0x0000 5E00	0x0000 5E7F	Yes	Yes
Sdfm2Regs	SDFM_REGS	0x0000 5E80	0x0000 5EFF	Yes	Yes
Peripheral Frame 2					
McbspaRegs	MCBSP_REGS	0x0000 6000	0x0000 603F	Yes	Yes
McbspbRegs	MCBSP_REGS	0x0000 6040	0x0000 607F	Yes	Yes
SpiaRegs	SPI_REGS	0x0000 6100	0x0000 610F	Yes	Yes
SpibRegs	SPI_REGS	0x0000 6110	0x0000 611F	Yes	Yes
SpicRegs	SPI_REGS	0x0000 6120	0x0000 612F	Yes	Yes
UppRegs ⁽²⁾	UPP_REGS	0x0000 6200	0x0000 62FF	Yes	Yes
Peripheral Frame 3					
WdRegs ⁽¹⁾	WD_REGS	0x0000 7000	0x0000 703F		
NmiIntruptRegs ⁽¹⁾	NMI_INTRUPT_REGS	0x0000 7060	0x0000 706F		
XintRegs ⁽¹⁾	XINT_REGS	0x0000 7070	0x0000 707F		
SciaRegs	SCI_REGS	0x0000 7200	0x0000 720F		
ScibRegs	SCI_REGS	0x0000 7210	0x0000 721F		
ScicRegs	SCI_REGS	0x0000 7220	0x0000 722F		
ScidRegs	SCI_REGS	0x0000 7230	0x0000 723F		
I2caRegs	I2C_REGS	0x0000 7300	0x0000 733F		
I2cbRegs	I2C_REGS	0x0000 7340	0x0000 737F		
AdcaRegs	ADC_REGS	0x0000 7400	0x0000 747F	Yes	
AdcbRegs	ADC_REGS	0x0000 7480	0x0000 74FF	Yes	
AdccRegs	ADC_REGS	0x0000 7500	0x0000 757F	Yes	
AdcdRegs	ADC_REGS	0x0000 7580	0x0000 75FF	Yes	
TrigRegs ⁽²⁾	TRIG_REGS	0x0000 7900	0x0000 791F		
DmaClaSrcSelRegs ⁽¹⁾	DMA_CLA_SRC_SEL_REGS	0x0000 7980	0x0000 798F		
EPwmXbarRegs ⁽²⁾	EPWM_XBAR_REGS	0x0000 7A00	0x0000 7A3F		
OutputXbarRegs ⁽²⁾	OUTPUT_XBAR_REGS	0x0000 7A80	0x0000 7ABF		
GpioCtrlRegs ⁽²⁾	GPIO_CTRL_REGS	0x0000 7C00	0x0000 7D7F		

Table 6-5. Peripheral Registers Memory Map (continued)

REGISTERS	STRUCTURE NAME	START ADDRESS	END ADDRESS	CLA ACCESS	DMA ACCESS
GpioDataRegs ⁽¹⁾	GPIO_DATA_REGS	0x0000 7F00	0x0000 7F2F	Yes	
UsbaRegs ⁽²⁾	USB_REGS	0x0004 0000	0x0004 0FFF		
Emif1Regs	EMIF_REGS	0x0004 7000	0x0004 77FF		
Emif2Regs ⁽²⁾	EMIF_REGS	0x0004 7800	0x0004 7FFF		
CanaRegs	CAN_REGS	0x0004 8000	0x0004 87FF		
CanbRegs	CAN_REGS	0x0004 A000	0x0004 A7FF		
IpcRegs ⁽¹⁾	IPC_REGS_CPU1 IPC_REGS_CPU2	0x0005 0000	0x0005 0FFF		
DevCfgRegs ⁽²⁾	DEV_CFG_REGS	0x0005 D000	0x0005 D19F		
AnalogSubsysRegs ⁽²⁾	ANALOG_SUBSYS_REGS	0x0005 D1A0	0x0005 D1FF		
ClkCfgRegs ⁽³⁾	CLK_CFG_REGS	0x0005 D200	0x0005 D2FF		
CpuSysRegs ⁽¹⁾	CPU_SYS_REGS	0x0005 D300	0x0005 D3FF		
RomPrefetchRegs ⁽²⁾	ROM_PREFETCH_REGS	0x0005 E608	0x0005 E60B		
DcsmZ1Regs ⁽¹⁾	DCSM_Z1_REGS	0x0005 F000	0x0005 F02F		
DcsmZ2Regs ⁽¹⁾	DCSM_Z2_REGS	0x0005 F040	0x0005 F05F		
DcsmCommonRegs ⁽¹⁾	DCSM_COMMON_REGS	0x0005 F070	0x0005 F07F		
MemCfgRegs ⁽¹⁾	MEM_CFG_REGS	0x0005 F400	0x0005 F47F		
Emif1ConfigRegs ⁽¹⁾	EMIF1_CONFIG_REGS	0x0005 F480	0x0005 F49F		
Emif2ConfigRegs ⁽²⁾	EMIF2_CONFIG_REGS	0x0005 F4A0	0x0005 F4BF		
AccessProtectionRegs ⁽¹⁾	ACCESS_PROTECTION_REGS	0x0005 F4C0	0x0005 F4FF		
MemoryErrorRegs ⁽¹⁾	MEMORY_ERROR_REGS	0x0005 F500	0x0005 F53F		
RomWaitStateRegs ⁽²⁾	ROM_WAIT_STATE_REGS	0x0005 F540	0x0005 F541		
FlashCtrlRegs ⁽¹⁾	FLASH_CTRL_REGS	0x0005 F800	0x0005 FAFF		
FlashEccRegs ⁽¹⁾	FLASH_ECC_REGS	0x0005 FB00	0x0005 FB3F		

(1) A unique copy of these registers exist on each CPU subsystem.

(2) These registers are only available on the CPU1 subsystem.

(3) These registers are mapped to either CPU1 or CPU2 based on a semaphore.

6.3 Device Identification Registers

Table 6-6. Device Identification Registers

NAME	ADDRESS	SIZE (x16)	DESCRIPTION
PARTIDH	0x0005 D00A	2	Device part identification number
			TMS320F28377D 0x00FF 0300
			TMS320F28376D TBD
			TMS320F28375D TBD
			TMS320F28374D TBD
REVID	0x0005 D00C	2	Silicon revision number
			Revision 0 0x0000 0000
			Revision A 0x0000 0000

6.4 Bus Architecture – Peripheral Connectivity

Table 6-7 shows a broad view of the peripheral and configuration register accessibility from each bus master. Peripherals can be individually assigned to the CPU1 or CPU2 subsystem (for example, ePWM can be assigned to CPU1 and eQEP assigned to CPU2). Peripherals within peripheral frames 1 or 2 will all be mapped to the respective secondary master as a group (if SPI is assigned to CPUx.DMA, then McBSP is also assigned to CPUx.DMA).

Table 6-7. Bus Master Peripheral Access

PERIPHERALS (BY BUS ACCESS TYPE)	CPU1.DMA	CPU1.CLA1	CPU1	CPU2	CPU2.CLA1	CPU2.DMA
Peripherals that can be assigned to CPU1 or CPU2 and have common selectable Secondary Masters						
Peripheral Frame 1: • ePWM/HRPWM • SDFM • eCAP ⁽¹⁾ • eQEP ⁽¹⁾ • CMPSS ⁽¹⁾ • DAC ⁽¹⁾	Y	Y	Y	Y	Y	Y
Peripheral Frame 2: • SPI • McBSP • uPP Configuration on CPU1 subsystem only (but still within Peripheral Frame 1) ⁽¹⁾	Y	Y	Y	Y	Y	Y
Peripherals that can be assigned to CPU1 or CPU2 subsystems						
SCI			Y	Y		
I ² C			Y	Y		
CAN			Y	Y		
ADC Configuration		Y	Y	Y	Y	
EMIF1	Y		Y	Y		Y
Peripherals and Device Configuration Registers only on CPU1 subsystem						
EMIF2		Y	Y			
USB and USB RAM	Y		Y			
Device Capability, Peripheral Reset, Peripheral CPU Select			Y			
GPIO Pin Mapping and Configuration			Y			
Analog System Control			Y			
uPP Message RAMs		Y	Y			
Reset Configuration			Y			
Accessible by only one CPU at a time with Semaphore						
Clock and PLL Configuration			Y	Y		
Peripherals and Registers with Unique Copies of Registers for each CPU and CLA Master⁽²⁾						
System Configuration (WD, NMIWD, LPM, Peripheral Clock Gating)			Y	Y		
Flash Configuration ⁽³⁾			Y	Y		
CPU Timers			Y	Y		
DMA and CLA Trigger Source Select			Y	Y		
GPIO Data ⁽⁴⁾		Y	Y	Y	Y	
ADC Results	Y	Y	Y	Y	Y	Y

(1) These modules are on a Peripheral Frame with DMA access; however, they do not support DMA transfers.

(2) Each CPUx and CPUx.CLA1 can only access its own copy of these registers.

(3) At any given time, only one CPU can perform program or erase operations on the Flash.

(4) The GPIO Data Registers are unique for each CPUx and CPUx.CLAx. When the GPIO Pin Mapping Register is configured to assign a GPIO to a particular master, the respective GPIO Data Register will control the GPIO. See the "General-Purpose Input/Output (GPIO)" chapter of the *TMS320F2837xD Delfino Microcontrollers Technical Reference Manual* (literature number [SPRUHM8](#)) for more details.

6.5 CPU and System Control

6.5.1 C28x Processor

The CPU is a 32-bit fixed-point processor. This device draws from the best features of digital signal processing; reduced instruction set computing (RISC); and microcontroller architectures, firmware, and tool sets.

The CPU features include a modified Harvard architecture and circular addressing. The RISC features are single-cycle instruction execution, register-to-register operations, and modified Harvard architecture. The microcontroller features include ease of use through an intuitive instruction set, byte packing and unpacking, and bit manipulation. The modified Harvard architecture of the CPU enables instruction and data fetches to be performed in parallel. The CPU can read instructions and data while it writes data simultaneously to maintain the single-cycle instruction operation across the pipeline. The CPU does this over six separate address/data buses.

For more information on CPU architecture and instruction set, see the *TMS320C28x CPU and Instruction Set Reference Guide* (literature number [SPRU430](#)).

6.5.1.1 Floating-Point Unit

The C28x plus floating-point (C28x+FPU) processor extends the capabilities of the C28x fixed-point CPU by adding registers and instructions to support IEEE single-precision floating point operations.

Devices with the C28x+FPU include the standard C28x register set plus an additional set of floating-point unit registers. The additional floating-point unit registers are the following:

- Eight floating-point result registers, RnH (where n = 0–7)
- Floating-point Status Register (STF)
- Repeat Block Register (RB)

All of the floating-point registers, except the repeat block register, are shadowed. This shadowing can be used in high-priority interrupts for fast context save and restore of the floating-point registers.

For more information, see the *TMS320C28x Extended Instruction Sets Reference Guide* (literature number [SPRUHS1](#)).

6.5.1.2 Trigonometric Math Unit

The TMU extends the capabilities of a C28x+FPU by adding instructions and leveraging existing FPU instructions to speed up the execution of common trigonometric and arithmetic operations listed in [Table 6-8](#).

Table 6-8. TMU Supported Instructions

INSTRUCTIONS	C EQUIVALENT OPERATION	PIPELINE CYCLES
MPY2PIF32 RaH,RbH	$a = b * 2\pi$	2/3
DIV2PIF32 RaH,RbH	$a = b / 2\pi$	2/3
DIVF32 RaH,RbH,RcH	$a = b/c$	5
SQRTF32 RaH,RbH	$a = \text{sqrt}(b)$	5
SINPUF32 RaH,RbH	$a = \sin(b*2\pi)$	4
COSPUF32 RaH,RbH	$a = \cos(b*2\pi)$	4
ATANPUF32 RaH,RbH	$a = \text{atan}(b)/2\pi$	4
QUADF32 RaH,RbH,RcH,RdH	Operation to assist in calculating ATANPU2	5

No changes have been made to existing instructions, pipeline or memory bus architecture. All TMU instructions use the existing FPU register set (R0H to R7H) to carry out their operations. A detailed explanation of the workings of the FPU can be found in the *TMS320C28x Extended Instruction Sets Reference Guide* (literature number [SPRUHS1](#)).

6.5.1.3 Viterbi, Complex Math, and CRC Unit II (VCU-II)

The VCU-II is the second-generation Viterbi, Complex Math, and CRC extension to the C28x CPU. The VCU-II extends the capabilities of the C28x CPU by adding registers and instructions to accelerate the performance of FFTs and communications-based algorithms. The C28x+VCU-II supports the following algorithm types:

- **Viterbi Decoding**

Viterbi decoding is commonly used in baseband communications applications. The Viterbi decode algorithm consists of three main parts: branch metric calculations, compare-select (Viterbi butterfly), and a traceback operation. [Table 6-9](#) shows a summary of the VCU performance for each of these operations.

Table 6-9. Viterbi Decode Performance

VITERBI OPERATION	VCU CYCLES
Branch Metric Calculation (code rate = 1/2)	1
Branch Metric Calculation (code rate = 1/3)	2p
Viterbi Butterfly (add-compare-select)	2 ⁽¹⁾
Traceback per Stage	3 ⁽²⁾

(1) C28x CPU takes 15 cycles per butterfly.

(2) C28x CPU takes 22 cycles per stage.

- **Cyclic Redundancy Check**

Cyclic redundancy check (CRC) algorithms provide a straightforward method for verifying data integrity over large data blocks, communication packets, or code sections. The C28x+VCU can perform 8-bit, 16-bit, 24-bit, and 32-bit CRCs. For example, the VCU can compute the CRC for a block length of 10 bytes in 10 cycles. A CRC result register contains the current CRC, which is updated whenever a CRC instruction is executed.

- **Complex Math**

Complex math is used in many applications, a few of which are:

- Fast Fourier Transform (FFT)

The complex FFT is used in spread spectrum communications, as well as in many signal processing algorithms.

- Complex filters

Complex filters improve data reliability, transmission distance, and power efficiency. The C28x+VCU can perform a complex I and Q multiply with coefficients (four multiplies) in a single cycle. In addition, the C28x+VCU can read/write the real and imaginary parts of 16-bit complex data to memory in a single cycle.

[Table 6-10](#) shows a summary of the VCU operations enabled by the VCU.

Table 6-10. Complex Math Performance

COMPLEX MATH OPERATION	VCU CYCLES	NOTES
Add or Subtract	1	32 +/- 32 = 32-bit (Useful for filters)
Add or Subtract	1	16 +/- 32 = 15-bit (Useful for FFT)
Multiply	2p	16 x 16 = 32-bit
Multiply and Accumulate (MAC)	2p	32 + 32 = 32-bit, 16 x 16 = 32-bit
RPT MAC	2p+N	Repeat MAC. Single cycle after the first operation.

For more information, see the *TMS320C28x Extended Instruction Sets Reference Guide* (literature number [SPRUHS1](#)).

6.5.2 Control Law Accelerator

The CLA is an independent single-precision (32-bit) floating-point unit processor with its own bus structure, fetch mechanism, and pipeline. Eight individual CLA tasks can be specified. Each task is started by software or a peripheral such as the ADC, ePWM, eCAP, eQEP, or CPU Timer 0. The CLA executes one task at a time to completion. When a task completes, the main CPU is notified by an interrupt to the PIE and the CLA automatically begins the next highest-priority pending task. The CLA can directly access the ADC Result registers, ePWM, eCAP, eQEP, Comparator and DAC registers. Dedicated message RAMs provide a method to pass additional data between the main CPU and the CLA.

Figure 6-2 shows the CLA block diagram.

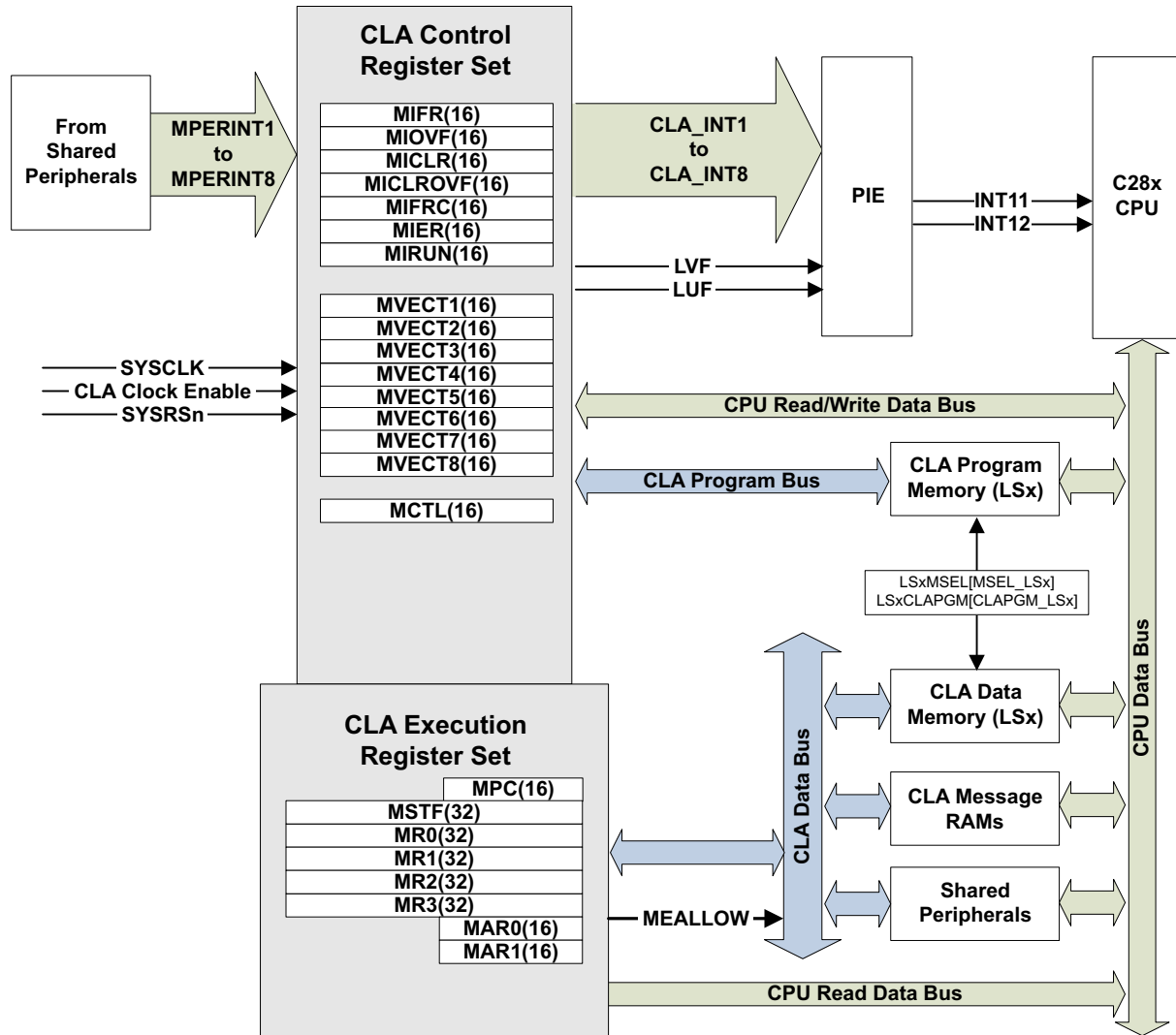

Figure 6-2. CLA Block Diagram

ADVANCE INFORMATION

6.5.3 Direct Memory Access

Each CPU has its own 6-channel DMA module. The DMA module provides a hardware method of transferring data between peripherals and/or memory without intervention from the CPU, thereby freeing up bandwidth for other system functions. Additionally, the DMA has the capability to orthogonally rearrange the data as it is transferred as well as “ping-pong” data between buffers. These features are useful for structuring data into blocks for optimal CPU processing.

The DMA module is an event-based machine, meaning it requires a peripheral or software trigger to start a DMA transfer. Although it can be made into a periodic time-driven machine by configuring a timer as the interrupt trigger source, there is no mechanism within the module itself to start memory transfers periodically. The interrupt trigger source for each of the six DMA channels can be configured separately and each channel contains its own independent PIE interrupt to let the CPU know when a DMA transfer has either started or completed. Five of the six channels are exactly the same, while Channel 1 has the ability to be configured at a higher priority than the others.

DMA features include:

- 6 channels with independent PIE interrupts
- Peripheral interrupt trigger sources
 - ADC interrupts and EVT signals
 - Multichannel buffered serial port transmit and receive
 - External interrupts
 - CPU timers
 - EPWMxSOC signals
 - SPIx transmit and receive
 - USBx transmit and receive
 - Sigma Delta Filter Module
 - Software trigger
- Data sources and destinations:
 - GSx RAM
 - CPU message RAM (IPC RAM)
 - USB RAM
 - ADC result registers
 - ePWMx
 - SPI
 - McBSP
 - EMIF
- Word Size: 16-bit or 32-bit (SPI and McBSP limited to 16-bit)
- Throughput: 4 cycles/word (without arbitration)

Figure 6-3 shows a device-level block diagram of the DMA for CPU1 and CPU2.

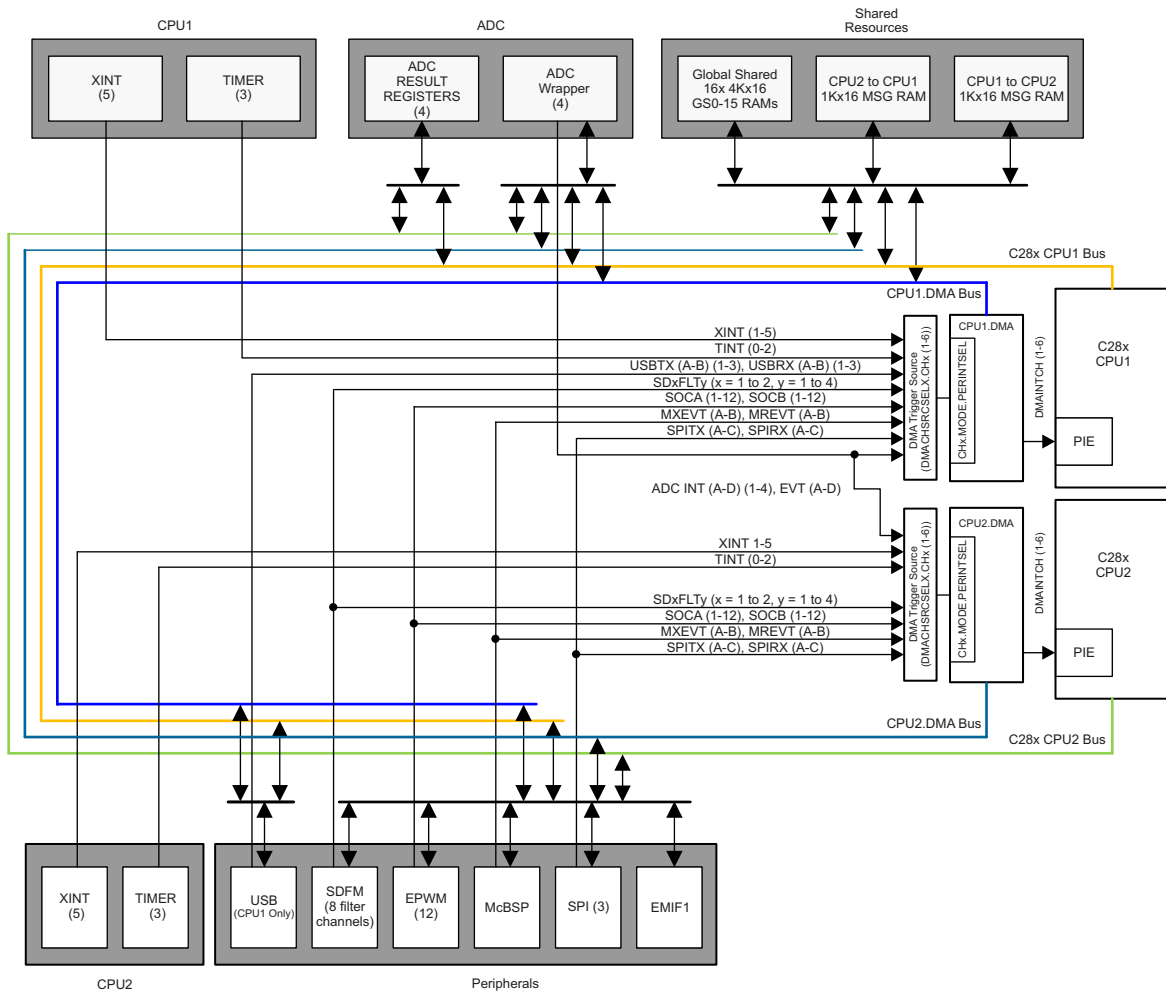

Figure 6-3. DMA Block Diagram

ADVANCE INFORMATION

6.5.4 Interprocessor Communication Module

The IPC module supports several methods of interprocessor communication:

- Thirty-two IPC flags per CPU, which can be used to signal events or indicate status via software polling. Four flags per CPU can generate interrupts.
- Shared data registers, which can be used to send commands or other small pieces of information between CPUs. Although the register names were chosen to support a command/response system, they can be used for any purpose as defined in software.
- Boot mode and status registers, which allow CPU1 to control the CPU2 boot process.
- A general-purpose free-running 64-bit counter.
- Two shared message RAMs, which can be used to transfer bulk data. Each RAM can be read by both CPUs. CPU1 can write to one RAM and CPU2 can write to the other.

Figure 6-4 shows the IPC architecture.

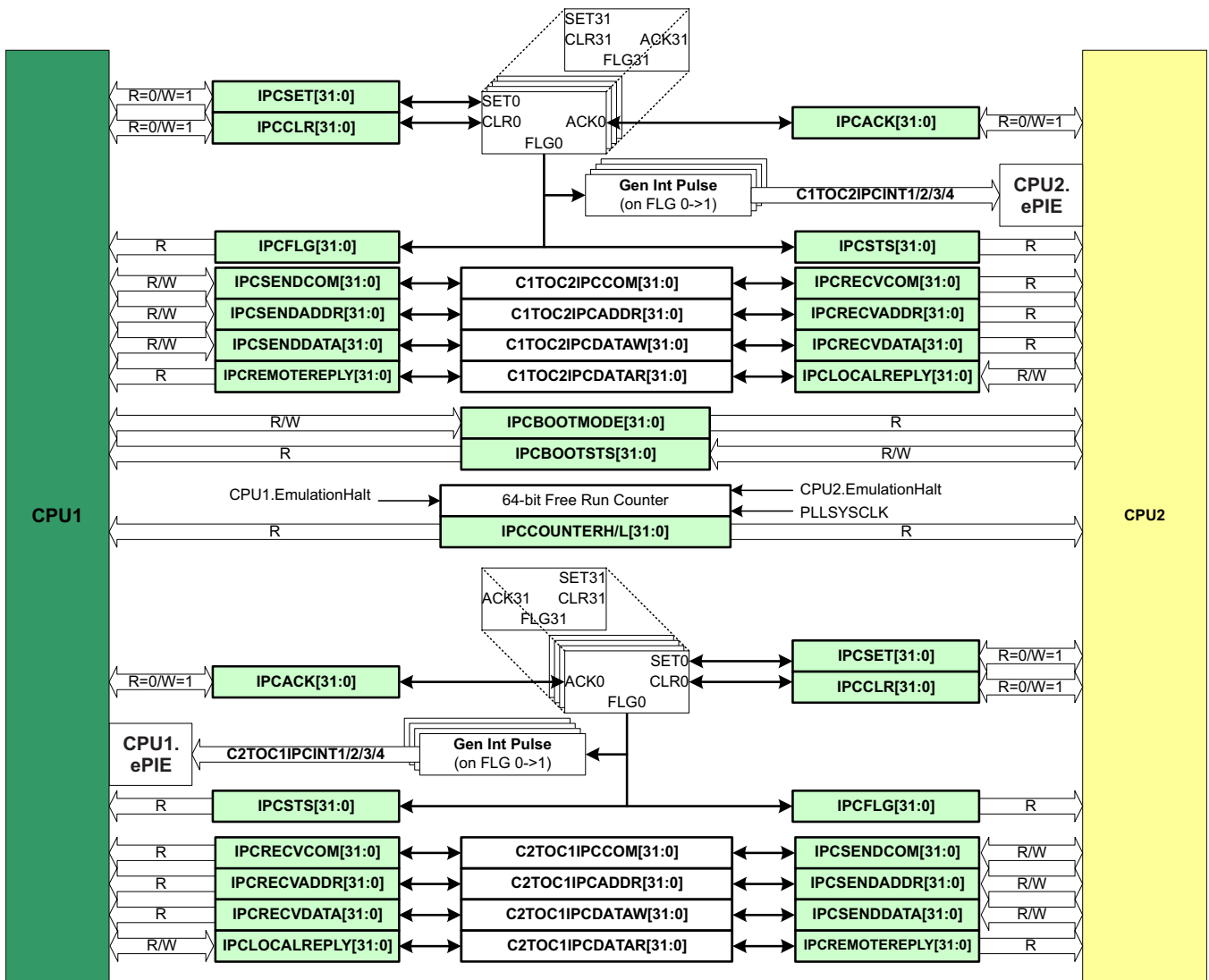

Figure 6-4. IPC Architecture

ADVANCE INFORMATION

6.5.5 Boot ROM and Peripheral Booting

The device boot ROM (on both the CPUs) is factory programmed with bootloading software. The CPU1 boot ROM does the system initialization before bringing CPU2 out of reset. The device boot ROM is executed each time the device comes out of reset. Users can configure the device to boot to flash (using GET mode) or choose to boot the device through one of the bootable peripherals by configuring the boot mode GPIO pins.

The CPU1 boot ROM, being master, owns the boot mode GPIO and boot configurations. The CPU2 boot ROM either boots to flash (if configured to do so via user configurable DCSM OTP) or enters a WAIT BOOT mode if no OTP is programmed. In WAIT BOOT mode, the CPU1 application instructs the CPU2 boot ROM on how to boot further using boot mode IPC commands supported by CPU2 boot ROM.

Table 6-11 shows the possible boot modes supported on the device. The default boot mode pins are GPIO72 (boot mode pin 1) and GPIO 84 (boot mode pin 0). Users may choose to have weak pullups for boot mode pins if they use a peripheral on these pins as well, so the pullups can be overdriven. On this device, customers can change the factory default boot mode pins by programming user configurable DCSM OTP locations. This is recommended only for cases in which the factory default boot mode pins do not fit into the customer design. More details on the locations to be programmed is available in the *TMS320F2837xD Delfino Microcontrollers Technical Reference Manual* (literature number [SPRUHM8](#)).

Table 6-11. Device Boot Mode – Decoded by CPU1

MODE NO.	CPU1 BOOT MODE	CPU2 BOOT MODE	$\overline{\text{TRST}}$	GPIO72 (BOOT MODE PIN 1)	GPIO84 (BOOT MODE PIN 0)
0	Parallel IO	Boot from Master	0	0	0
1	SCI Mode	Boot from Master	0	0	1
2	Wait Boot Mode	Boot from master	0	1	0
3	Get Mode	Boot from Master	0	1	1
4-7	EMU Boot Mode (Emulator Connected)	Boot from Master	1	X	X

6.5.5.1 EMU Boot or Emulation Boot

The CPU enters this boot when it detects that $\overline{\text{TRST}}$ is HIGH (in other words, when an emulator/debugger is connected). In this mode, the user can program the EMUBOOTCTRL register (at location 0xD00) to instruct the device on how to boot. If the contents of the EMUBOOTCTRL locations are invalid, then the device would default into WAIT Boot mode. The emulation boot allows users to verify the device boot before programming the boot mode into OTP.

6.5.5.2 WAIT Boot Mode

The device in this boot mode loops in the boot ROM. This mode is useful if users want to connect a debugger on a secure device or if users do not want the device to execute an application in flash yet.

6.5.5.3 Get Mode

The default behavior of Get mode is boot-to-flash. This behavior can be changed by programming the Zx-OTPBOOTCTRL locations in user configurable DCSM OTP. The user configurable DCSM OTP on this device is divided in to two secure zones: Z1 and Z2. The Get mode function in boot ROM first checks if a valid OTPBOOTCTRL value is programmed in Z1. If the answer is yes, then the device boots as per the Z1-OTPBOOTCTRL location. The Z2-OTPBOOTCTRL location is read and decodes only if Z1-OTPBOOTCTRL is invalid or not programmed. If either Zx-OTPBOOTCTRL location is not programmed, then the device defaults to factory default operation, which is to use factory default boot mode pins to boot to flash if the boot mode pins are set to GET MODE. Users can choose the device through which to boot—SPI, I2C, CAN and USB—by programming proper values into the user configurable DCSM OTP. More details on this can be found in the *TMS320F2837xD Delfino Microcontrollers Technical Reference Manual* (literature number [SPRUHM8](#)).

6.5.5.4 Peripheral Pins used by Bootloaders

[Table 6-12](#) shows the GPIO pins used by each peripheral bootloader. This device supports two sets of GPIOs for each mode, as shown in [Table 6-12](#).

Table 6-12. GPIO Pins Used by Each Peripheral Bootloader

BOOTLOADER	GPIO PINS	NOTES
SCI-Boot0	SCITXDA: GPIO84 SCIRXDA: GPIO85	SCIA Boot IO option 1 (default SCl option when chosen through Boot Mode GPIOs)
SCI-Boot1	SCITXDA: GPIO28 SCIRXDA: GPIO29	SCIA Boot option 2 – with alternate IOs.
Parallel Boot	D0 – GPIO65 D1 – GPIO64 D2 – GPIO58 D3 – GPIO59 D4 – GPIO60 D5 – GPIO61 D6 – GPIO62 D7 – GPIO63 HOST_CTRL – GPIO70 DSP_CTRL – GPIO69	
CAN-Boot0	CANRXA: GPIO70 CANTXA: GPIO71	CAN-A Boot -IO Option 1
CAN-Boot1	CANRXA: GPIO62 CANTXA: GPIO63	CAN-A Boot -IO option 2
I2C-Boot0	SDAA: GPIO91 SCLA: GPIO92	I2CA Boot- IO option 1
I2C-Boot1	SDAA: GPIO32 SCLA: GPIO33	I2CA Boot- IO option 2
SPI-Boot0	SPISIMOA - GPIO58 SPISOMIA - GPIO59 SPICLKA - GPIO60 SPISTEA - GPIO61	SPIA Boot- IO Option 1
SPI-Boot1	SPISIMOA – GPIO16 SPISOMIA – GPIO17 SPICLKA – GPIO18 SPISTEA – GPIO19	SPIA Boot - IO Option 2
USB Boot	USB0DM - GPIO42 USB0DP - GPIO43	CPU1 Only (USB Boot implements USB custom DFU device type)

6.5.6 Memory

6.5.6.1 Dedicated RAM (Mx and Dx RAM)

Each CPU subsystem has four dedicated ECC-capable RAM blocks: M0, M1, D0, and D1. M0/M1 memories are small non-secure blocks that are tightly coupled with the CPU (that is, only the CPU has access to them). D0/D1 memories are secure blocks and also have the access-protection feature (CPU write/CPU fetch protection).

6.5.6.2 Local Shared RAM (LSx RAM)

RAM blocks which are dedicated to each subsystem and are accessible to its CPU and CLA only, are called local shared RAMs (LSx RAMs).

All LSx RAM blocks have parity. These memories are secure and have the access protection (CPU write/CPU fetch) feature.

By default, these memories are dedicated to the CPU only, and the user could choose to share these memories with the CLA by configuring the MSEL_LSx bit field in the LSxMSEL registers appropriately.

**Table 6-13. Master Access for LSx RAM
(With Assumption That all Other Access Protections are Disabled)**

MSEL_LSx	CLAPGM_LSx	CPUx ALLOWED ACCESS	CPUx.CLA1 ALLOWED ACCESS	COMMENT
00	X	All	–	LSx memory is configured as CPU dedicated RAM.
01	0	All	Data Read Data Write	LSx memory is shared between CPU and CLA1.
01	1	Emulation Read Emulation Write	Fetch Only	LSx memory is CLA1 program memory.

6.5.6.3 Global Shared RAM (GSx RAM)

RAM blocks which are accessible from both the CPU and DMA are called global shared RAMs (GSx RAMs). Each shared RAM block can be owned by either CPU subsystem based on the configuration of respective bits in the GSxMSEL register.

When a GSx RAM block is owned by a CPU subsystem, the CPUx and CPUx.DMA will have full access to that RAM block whereas the other CPUy and CPUy.DMA will only have read access (no fetch/write access).

**Table 6-14. Master Access for GSx RAM
(With Assumption That all Other Access Protections are Disabled)**

GSxMSEL	CPU1 FETCH	CPU1 READ	CPU1 WRITE	CPU1.DMA READ	CPU1.DMA WRITE	CPU2 FETCH	CPU2 READ	CPU2 WRITE	CPU2.DMA READ	CPU2.DMA WRITE
0	Yes	Yes	Yes	Yes	Yes	No	Yes	No	Yes	No
1	No	Yes	No	Yes	No	Yes	Yes	Yes	Yes	Yes

All these RAMs have access protection (CPU write/CPU fetch/DMA write).

6.5.6.4 Message RAM (MSGRAM)

These RAM blocks are used to share data between the CPU and CLA of the same subsystem, or between CPU1 and CPU2. Since these RAMs are used for interprocessor communication, they are also called IPC RAMs.

The message RAMs between two CPUs will have CPU/DMA read/write access from one subsystem, and CPU/DMA read only access from the other subsystem. Similarly, for message RAMs between CPU and CLA of the same subsystem, either the CPU or CLA will have read/write access and the other one will have only read access.

All MSGRAMs have parity.

6.5.7 Dual Code Security Module

The dual code security module (DCSM) prevents access to on-chip secure memories. The term “secure” means access to secure memories and resources is blocked. The term “unsecure” means access is allowed; for example, through a debugging tool such as Code Composer Studio.

The code security mechanism offers protection for two zones, Zone 1 (Z1) and Zone 2 (Z2). The security implementation for both the zones is identical. Each zone has its own dedicated secure resource and allocated secure resource.

The security of each zone is ensured by its own 128-bit password (CSM password). The password for each zone is stored in an OTP memory location based on a zone-specific link pointer. The link pointer value can be changed to program a different set of security settings (including passwords) in OTP. The secure resources available are: OTP memory, CLA, LSx RAM, flash sectors, and secure ROM.

6.5.8 Timers

CPU-Timers 0, 1, and 2 are identical 32-bit timers with presetable periods and with 16-bit clock prescaling. The timers have a 32-bit count-down register that generates an interrupt when the counter reaches zero. The counter is decremented at the CPU clock speed divided by the prescale value setting. When the counter reaches zero, it is automatically reloaded with a 32-bit period value.

CPU-Timer 0 is for general use and is connected to the PIE block. CPU-Timer 1 is also for general use and is connected to INT13 of the CPU. CPU-Timer 2 is reserved for SYSBIOS. It is connected to INT14 of the CPU. If SYSBIOS is not being used, CPU-Timer 2 is available for general use.

CPU-Timer 2 can be clocked by any one of the following:

- CPUx.SYSCLK (default)
- Internal zero-pin oscillator 1 (INTOSC1)
- Internal zero-pin oscillator 2 (INTOSC2)
- External clock source

6.5.9 Interrupts

Figure 6-5 provides a high-level view of the interrupt architecture.

As shown in Figure 6-5, the devices support five external interrupts (XINT1 to XINT5) that can be mapped onto any of the GPIO pins.

In this device, sixteen ePIE block interrupts are grouped into one CPU interrupt. In total, there are 12 CPU interrupt groups, with 16 interrupts per group.

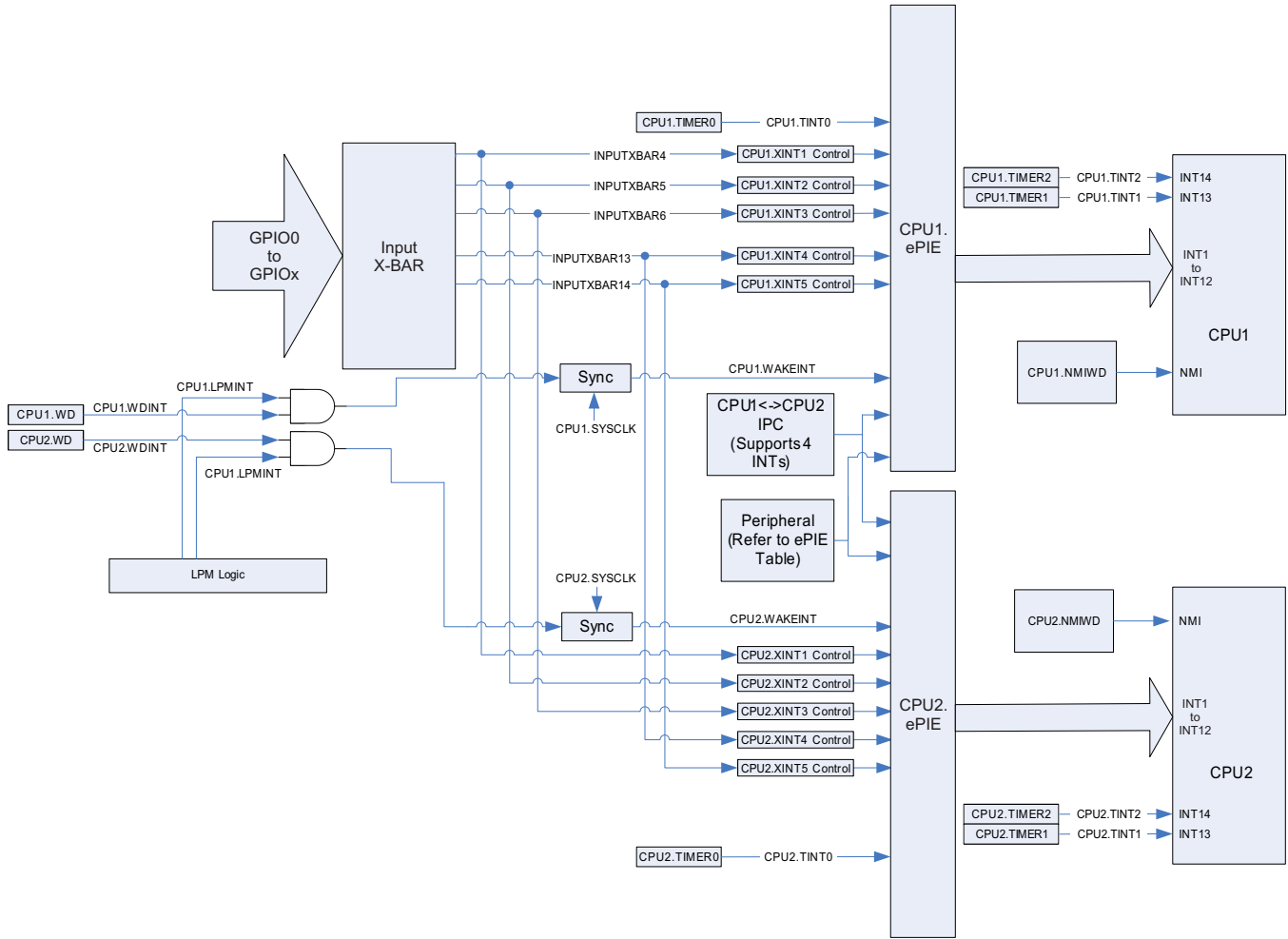

Figure 6-5. External and ePIE Interrupt Sources

6.5.10 Nonmaskable Interrupt Watchdog

The non-maskable interrupt (NMI) is used to monitor erroneous conditions in the system. There is a NMIWD module for each CPU. The conditions monitored are:

- A missing clock condition
- Uncorrectable memory errors on C28x access to Flash
- Uncorrectable memory errors on C28x, CLA, or DMA access to RAM
- Vector fetch ERROR on the other CPU

If the software does not respond to the enabled latched FAIL condition, then the NMI watchdog will trigger a reset after a preprogrammed time interval.

6.5.11 Watchdog

The watchdog module is the same as the one on previous C2000™ devices, but with an optional lower limit on the time between software resets of the counter. This windowed countdown is disabled by default, so the watchdog is fully backwards-compatible.

The watchdog is capable of generating either a reset or an interrupt. It is clocked from the internal oscillator with a selectable frequency divider.

Figure 6-6 shows the various functional blocks within the watchdog module.

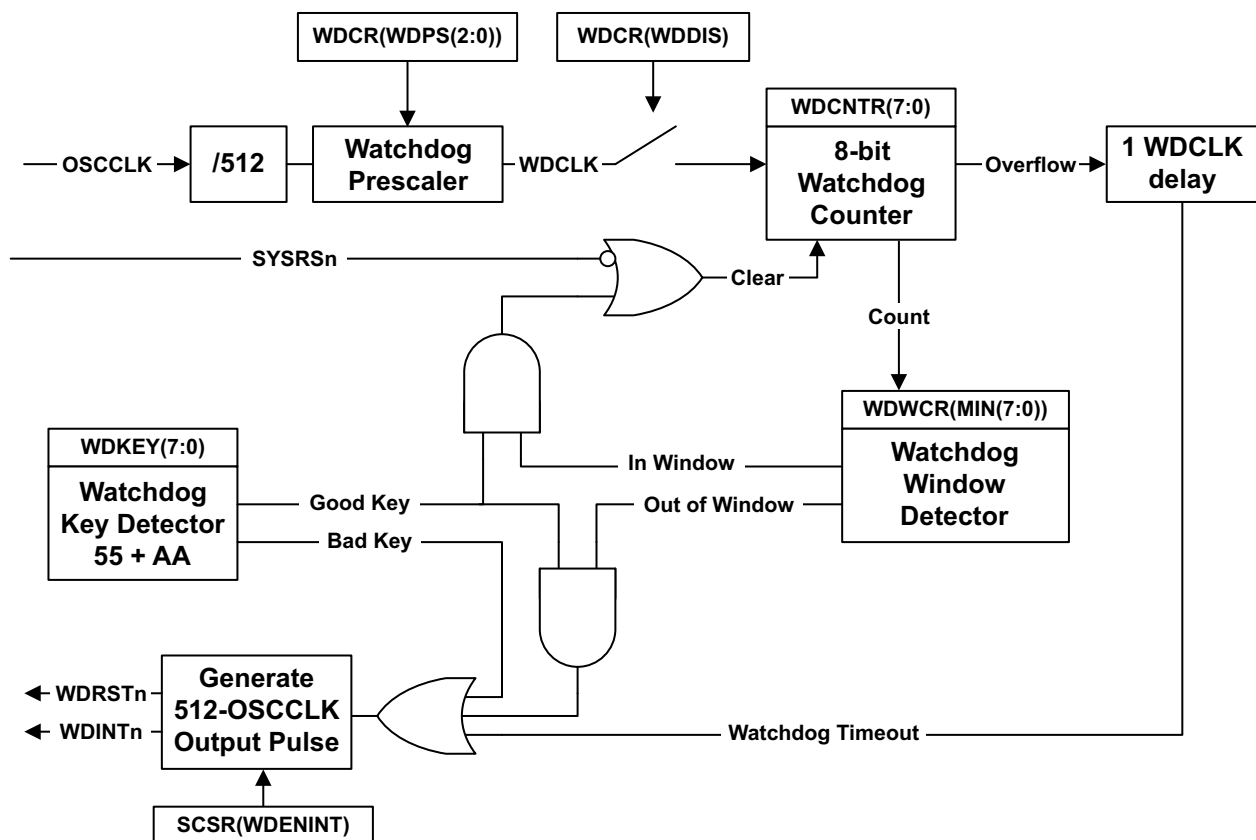

Figure 6-6. Windowed Watchdog

6.5.12 Low-Power Modes

This device has three clock-gating low-power modes and a special power-gating mode.

Further details, as well as the entry and exit procedure, for all of the low-power modes can be found in the "Low Power Modes" section of the *TMS320F2837xD Delfino Microcontrollers Technical Reference Manual* (literature number [SPRUHM8](#)).

6.5.12.1 Clock-Gating Low-Power Modes

IDLE, STANDBY, and HALT modes on this device are similar to those on other C28x devices. [Table 6-15](#) describes the effect on the system when any of the clock-gating low-power modes are entered.

Table 6-15. Effect of Clock-Gating Low-Power Modes on the Device

MODULES/ CLOCK DOMAIN	CPU1 IDLE	CPU1 STANDBY	CPU2 IDLE	CPU2 STANDBY	HALT
CPU1.CLKIN	Active	Gated	N/A	N/A	Gated
CPU1.SYSCLK	Active	Gated	N/A	N/A	Gated
CPU1.CPUCLK	Gated	Gated	N/A	N/A	Gated
CPU2.CLKIN	N/A	N/A	Active	Gated	Gated
CPU2.SYSCLK	N/A	N/A	Active	Gated	Gated
CPU2.CPUCLK	N/A	N/A	Gated	Gated	Gated
Clock to modules Connected to PERx.SYSCLK	Active	Gated if CPUSEL.PERx = CPU1	Active	Gated if CPUSEL.PERx = CPU2	Gated
WD1CLK	Active	Active	Active	Active	Gated if CLKSRCCTL1.WDHALTI = 0
WD2CLK	Active	Active	Active	Active	Gated
AUXPLLCLK	Active	Active	Active	Active	Gated
PLL	Powered	Powered	Powered	Powered	Powered-Down
INTOSC1	Powered	Powered	Powered	Powered	Powered down if CLKSRCCTL1.WDHALTI = 0
INTOSC2	Powered	Powered	Powered	Powered	Powered down if CLKSRCCTL1.WDHALTI = 0
Flash	Powered	Powered	Powered	Powered	Software-Controlled
X1,X2 OSC	Powered	Powered	Powered	Powered	Powered-Down

6.5.12.2 Power-Gating Low-Power Modes

HIBERNATE mode is the lowest power mode on this device. It is a global low-power mode that gates the supply voltages to most of the system. HIBERNATE is essentially a controlled power-down with remote wakeup capability, and can be used to save power during long periods of inactivity. [Table 6-16](#) describes the effects on the system when the HIBERNATE mode is entered.

Table 6-16. Effect of Power-Gating Low-Power Mode on the Device

MODULES/POWER DOMAINS	HIBERNATE
CPUx's M0 and M1 memories	<ul style="list-style-type: none"> Remain on with memory retention if CPUx.LPMCR.M0M1MODE = 0x00 Are off when CPUx.LPMCR.M0M1MODE = 0x01
CPU1, CPU2, digital peripherals	Powered down
Dx, LSx, GSx memories	Power down, memory contents are lost
IOs	On with output state preserved
Oscillators, PLL, analog peripherals, Flash	Enters Low-Power Mode

6.6 Peripheral Information and Timings

NOTE

For the actual number of each peripheral on a specific device, see [Table 3-1](#).

6.6.1 Analog Peripherals

The analog subsystem consists of:

- Four ADCs with selectable resolution of 16 bits or 12 bits
- Eight comparator subsystems, each containing a 12-bit reference DAC, two comparators, and a digital deglitching filter
- Three 12-bit buffered output DACs

[Figure 6-7](#) shows the Analog Subsystem Block Diagram for the 337-ball ZWT package. [Figure 6-8](#) shows the Analog Subsystem Block Diagram for the 176-pin PTP package.

ADVANCE INFORMATION

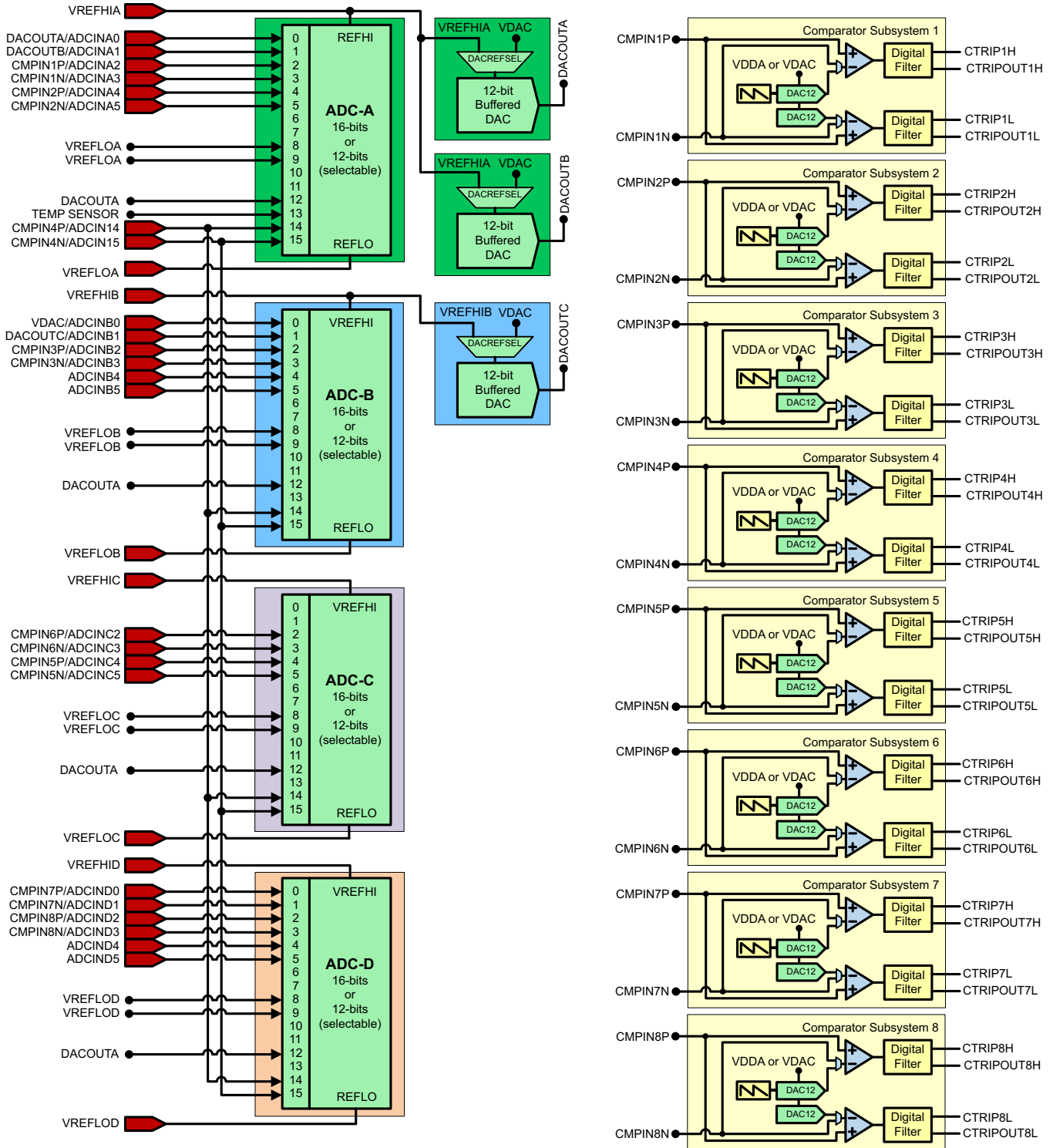

Figure 6-7. Analog Subsystem Block Diagram (337-Ball ZWT)

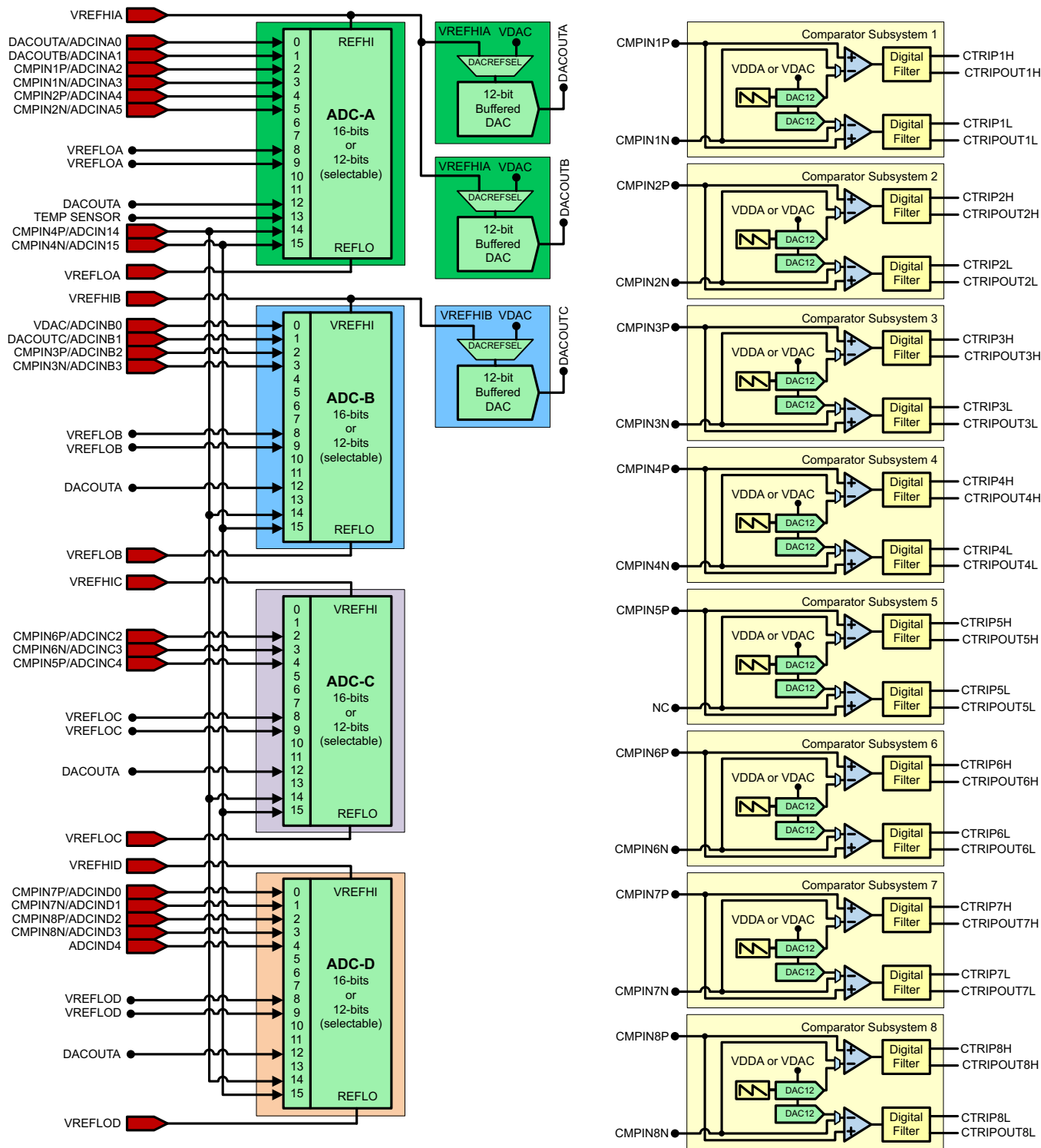

Figure 6-8. Analog Subsystem Block Diagram (176-Pin PTP)

ADVANCE INFORMATION

6.6.1.1 Analog-to-Digital Converter

The ADCs on this device are successive approximation (SAR) style ADCs with selectable resolution of either 16 bits or 12 bits. There are multiple ADC modules, allowing simultaneous sampling or independent operation. The ADC wrapper is start-of-conversion (SOC) based [see the "SOC Principle of Operation" section of the *TMS320F2837xD Delfino Microcontrollers Technical Reference Manual* (literature number [SPRUHM8](#))].

Each ADC has the following features:

- Selectable resolution of 16 bits or 12 bits
- Ratiometric external reference set by V_{REFHI} and V_{REFLO}
- Differential signal conversions
- Single-ended signal conversions (12-bit mode only)
- Input multiplexer with up to 16 channels (single-ended) or 8 channels (differential)
- 16 configurable SOCs
- 16 individually addressable result registers
- Multiple trigger sources
 - Software immediate start
 - All ePWMs - ADCSOC A, B, C, or D
 - GPIO XINT2
 - CPU timers
 - ADCINT1 or 2
- Four flexible PIE interrupts
- Burst mode
- Four post-processing blocks, each with:
 - Saturating offset calibration
 - Error from setpoint calculation
 - High, low, and zero-crossing compare, with interrupt and ePWM trip capability
 - Trigger-to-sample delay capture

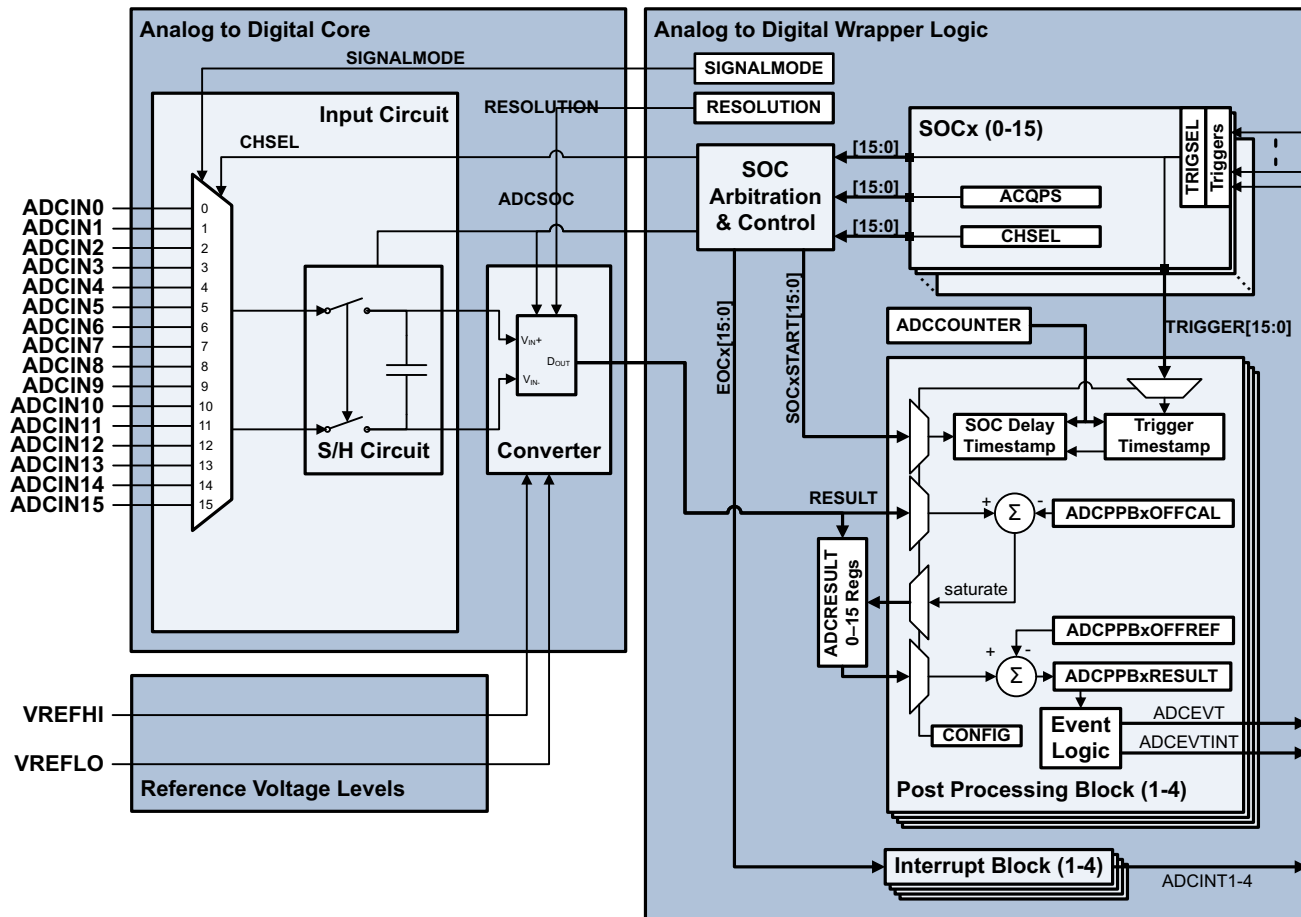

Figure 6-9. ADC Module Block Diagram

ADVANCE INFORMATION

6.6.1.2 Buffered Digital-to-Analog Converter

The buffered DAC module consists of an internal reference DAC and an analog output buffer that is capable of driving an external load. An integrated pull-down resistor on the DAC output helps to provide a known pin voltage when the output buffer is disabled. This pull-down resistor cannot be disabled and remains as a passive component on the pin, even for other shared pin mux functions. Software writes to the DAC value register can take effect immediately or can be synchronized with PWMSYNC events.

Each Buffered DAC has the following features:

- 12-bit programmable internal DAC
- Selectable reference voltage
- Analog output buffer with programmable gain setting (Gain = 1 or Gain = 2)
- Pull-down resistor on output
- Ability to synchronize with PWMSYNC

The block diagram for the buffered DAC is shown in [Figure 6-10](#).

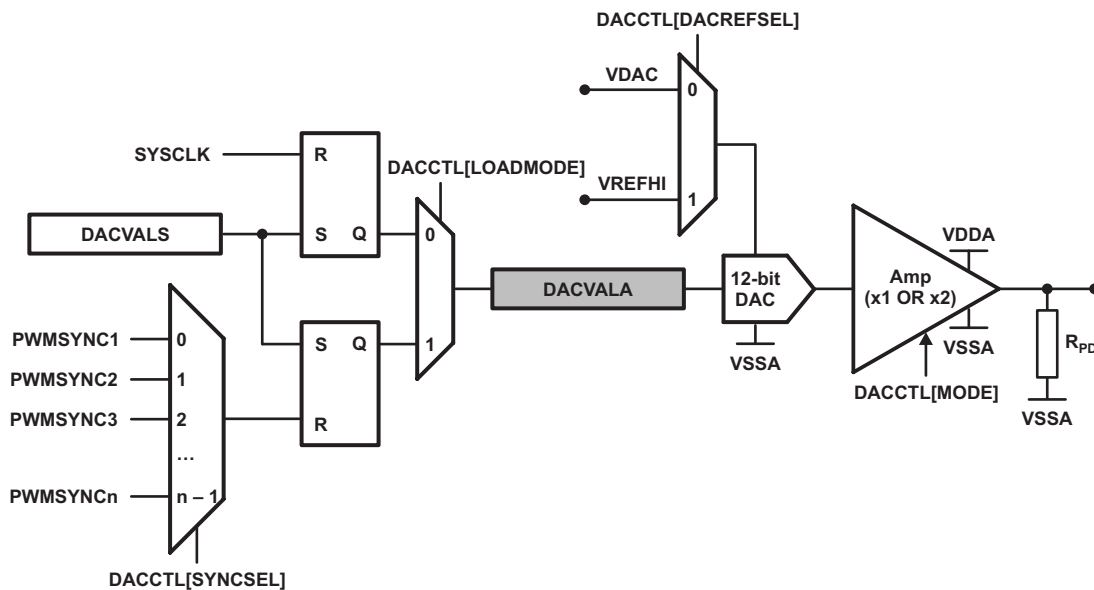

Figure 6-10. DAC Module Block Diagram

6.6.1.3 Comparator Subsystem

Each CMPSS module includes two sets of comparators, internal voltage reference DACs, digital glitch filters, and ramp generator logic. There are two inputs, CMPINxP and CMPINxN. Each of these will be internally connected to an ADCIN pin. The CMPINxP pin is always connected to the positive input of the CMPSS comparators. CMPINxN can be used instead of the DAC output to drive the negative comparator inputs. There are two comparators, and therefore two outputs from the CMPSS module, which are connected to the input of a digital filter module before being passed on to the Comparator TRIP crossbar and either PWM modules or directly to a GPIO pin. Figure 6-11 shows the CMPSS connectivity.

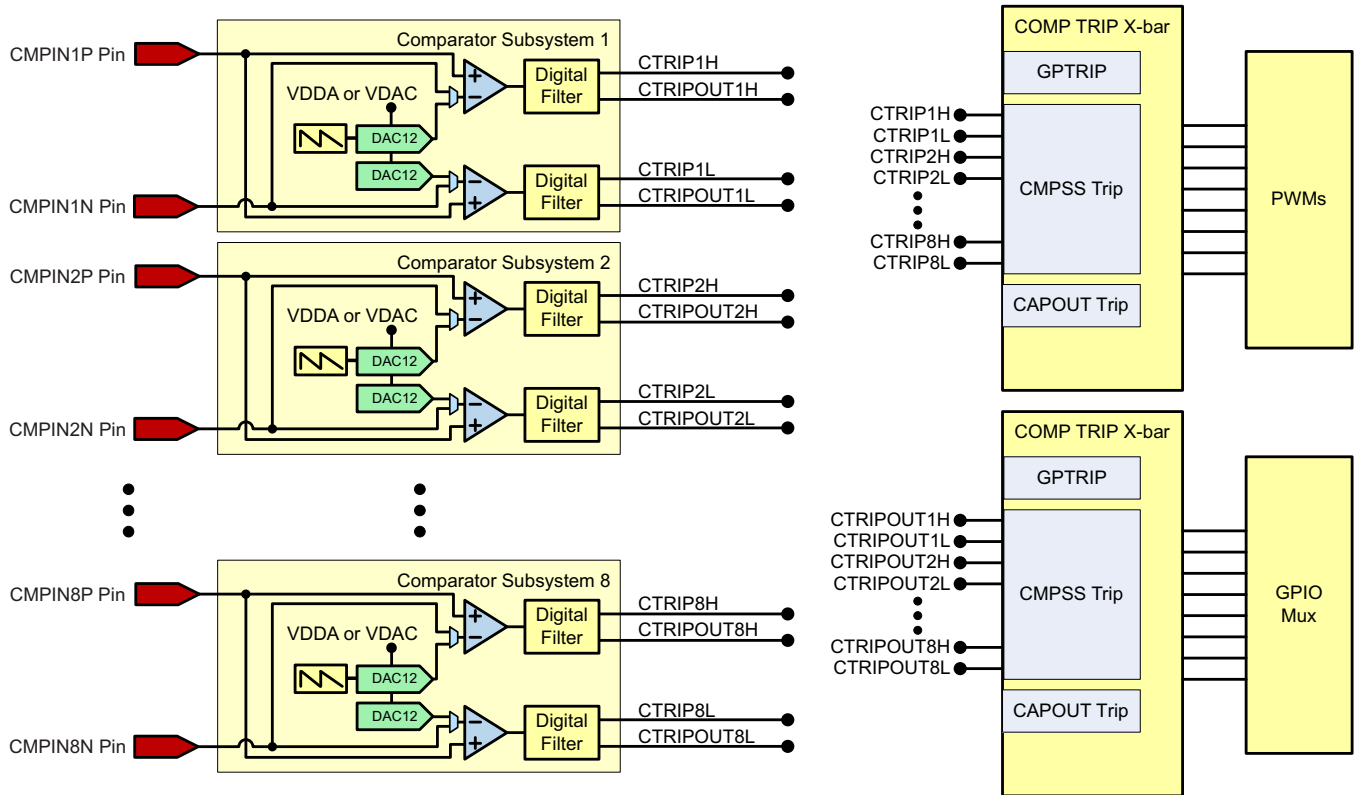

Figure 6-11. CMPSS Connectivity

ADVANCE INFORMATION

6.6.2 Control Peripherals

6.6.2.1 Sigma Delta Filter Module

The SDFM is a four-channel digital filter designed specifically for current measurement and resolver position decoding in motor control applications. Each channel can receive an independent sigma-delta ($\Sigma\Delta$) modulated bit stream. The bit streams are processed by four individually programmable digital decimation filters. The filter set includes a fast comparator for immediate digital threshold comparisons for over-current and under-current monitoring. The flexible SDFM also offers a filter-bypass mode to enable data logging, analysis, and customized filtering. [Figure 6-12](#) shows a block diagram of the SDFMs.

SDFM features include:

- Four external pins per SDFM module:
 - Four sigma delta data input pins per SDFM module (SD-Dx, where x = 1 to 4)
 - Four sigma delta clock input pins per SDFM module (SD-Cx, where x = 1 to 4)
- Four different configurable modulator clock modes:
 - Modulator clock rate equals modulator data rate
 - Modulator clock rate running at half the modulator data rate
 - Modulator data is Manchester encoded. Modulator clock not required.
 - Modulator clock rate is double that of modulator data rate
- Four independent configurable comparator units:
 - Four different filter type selection (Sinc1/Sinc2/Sincfast/Sinc3) options available
 - Ability to detect over-value and under-value conditions
 - OSR value for comparator programmable from 1 to 32
- Four independent configurable sinc filter units:
 - Four different filter type selection (Sinc1/Sinc2/Sincfast/Sinc3) options available
 - Ability to bypass filter module
 - OSR value for filter unit programmable from 1 to 256
 - Ability to enable or disable individual filter module
 - Ability to synchronize all four independent filters of a SDFM module using the Master Filter Enable (MFE) bit or the PWM signals.
- Filter data can be 16-bit or 32-bit representation
- PWMs can be used to generate modulator clock for sigma delta modulators

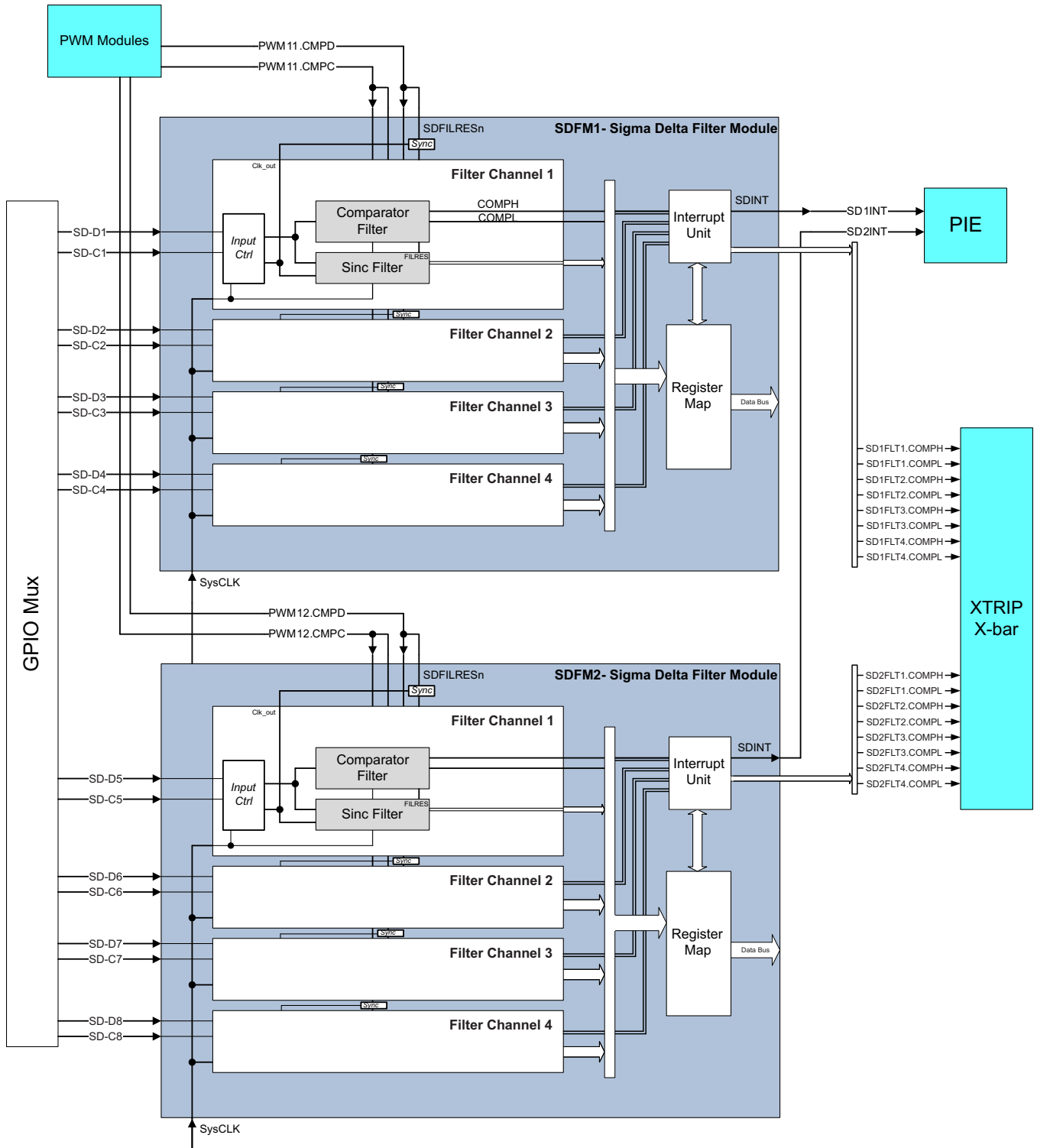

ADVANCE INFORMATION

Figure 6-12. SDFM

6.6.2.2 Enhanced Pulse Width Modulator

The ePWM peripheral is a key element in controlling many of the power electronic systems found in both commercial and industrial equipment. The ePWM type-4 module is able to generate complex pulse width waveforms with minimal CPU overhead by building the peripheral up from smaller modules with separate resources that can operate together to form a system. Some of the highlights of the ePWM type-4 module include complex waveform generation, dead-band generation, a flexible synchronization scheme, advanced trip-zone functionality, and global register reload capabilities.

[Figure 6-13](#) shows the signal interconnections with the ePWM.

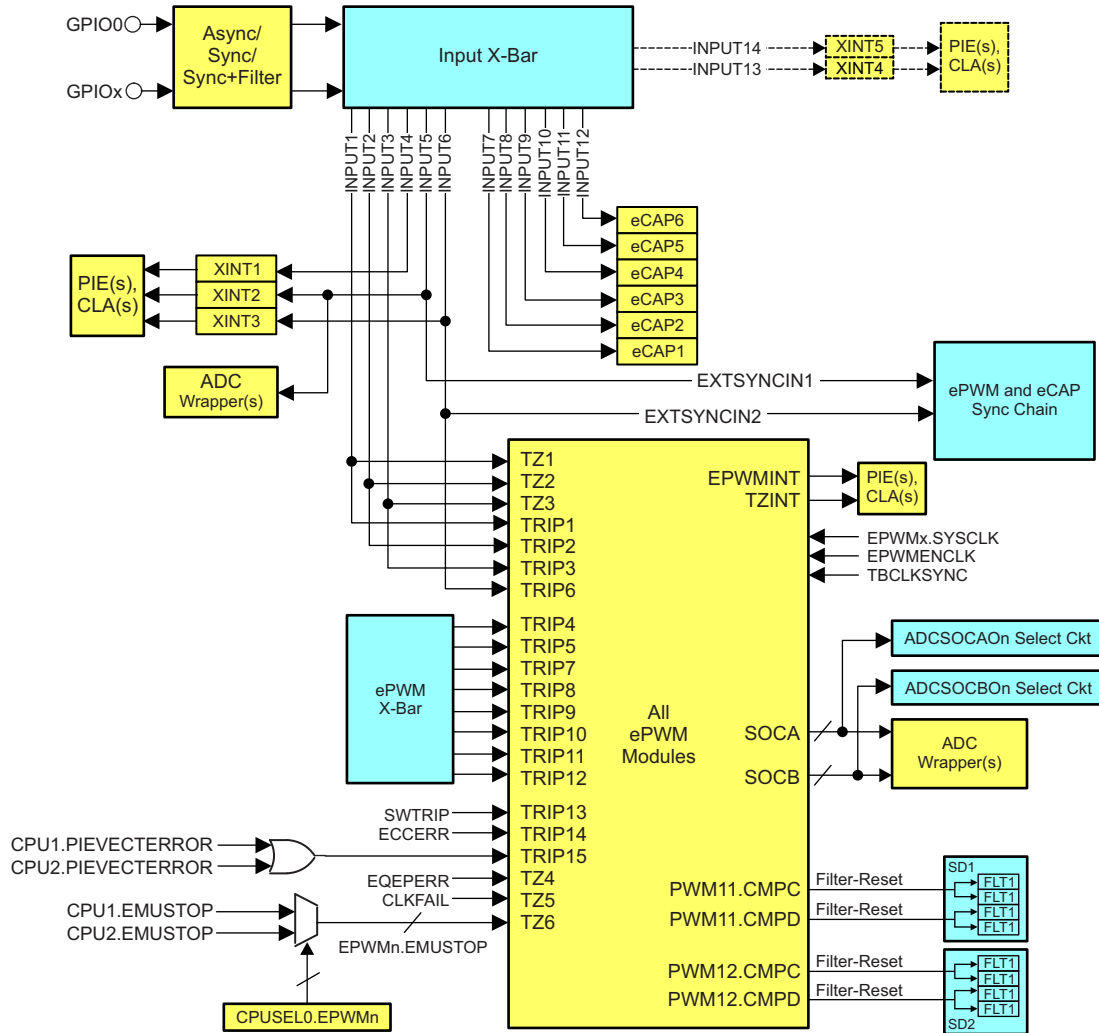
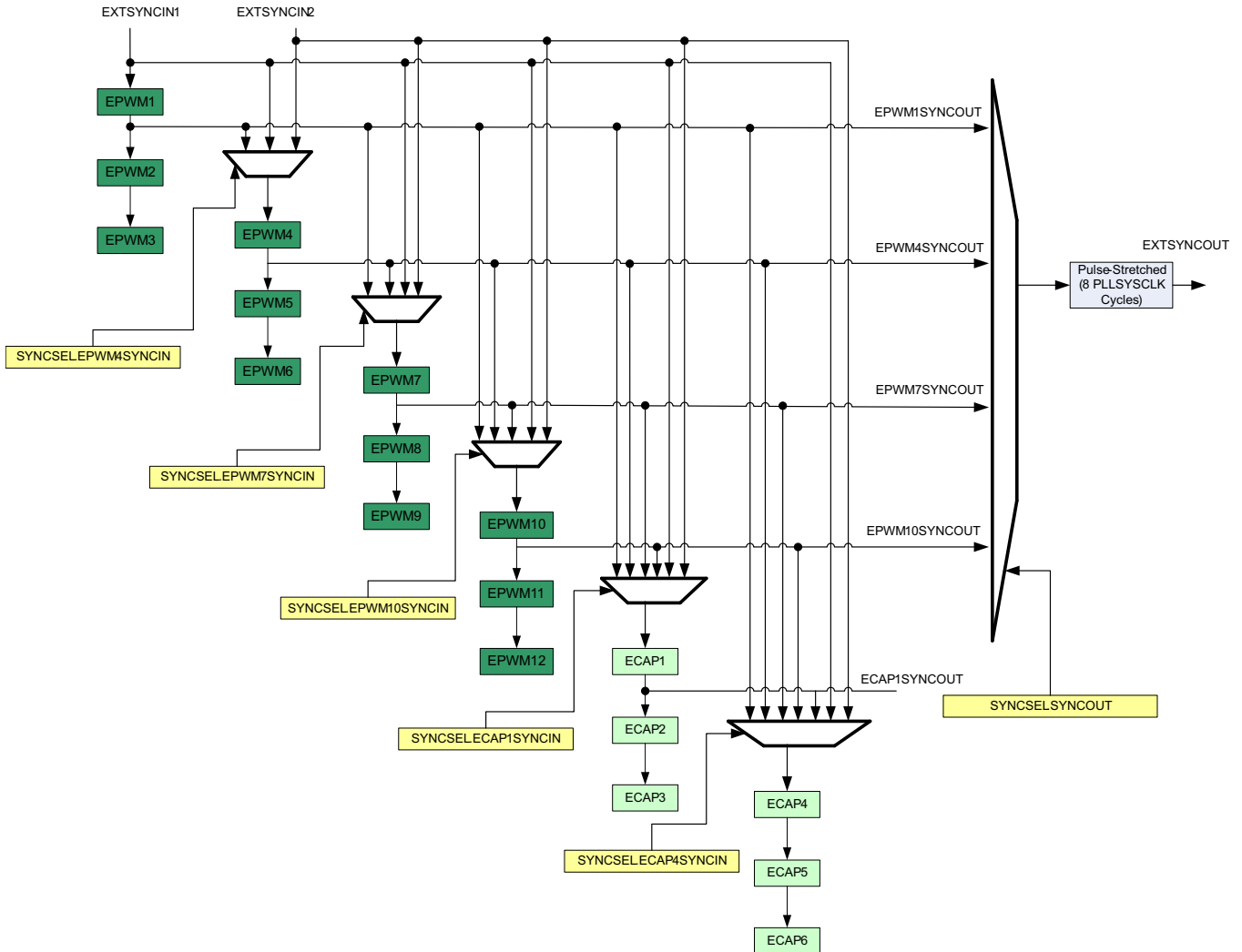

Figure 6-14. ePWM

ADVANCE INFORMATION

6.6.2.2.1 Control Peripherals Synchronization

The ePWM and eCAP Synchronization Chain on the device provides flexibility in partitioning the ePWM and eCAP modules between CPU1 and CPU2 and allows localized synchronization within the modules belonging to the same CPU. Like all F2837xD peripherals, the partitioning of the ePWM and eCAP modules needs to be done using the CPUSELx registers. Figure 6-15 shows the Synchronization Chain Architecture.



ADVANCE INFORMATION

Figure 6-15. Synchronization Chain Architecture

6.6.2.3 High-Resolution Pulse Width Modulator

The HRPWM combines multiple delay lines in a single module and a simplified calibration system by using a dedicated calibration delay line. For each ePWM module there is one HR delay line.

The HRPWM module offers PWM resolution (time granularity) that is significantly better than what can be achieved using conventionally derived digital PWM methods. The key points for the HRPWM module are:

- Significantly extends the time resolution capabilities of conventionally derived digital PWM
- This capability can be utilized in both single edge (duty cycle and phase-shift control) as well as dual edge control for frequency/period modulation.
- Finer time granularity control or edge positioning is controlled via extensions to the Compare A, phase, and period registers of the ePWM module.

NOTE

The minimum HRPWMCLK frequency allowed for HRPWM is 60 MHz.

NOTE

When dual-edge high-resolution is enabled (high-resolution period mode), the PWMxB output is not available for use.

6.6.2.4 Enhanced Capture

Figure 6-16 shows the block diagram of an eCAP module.

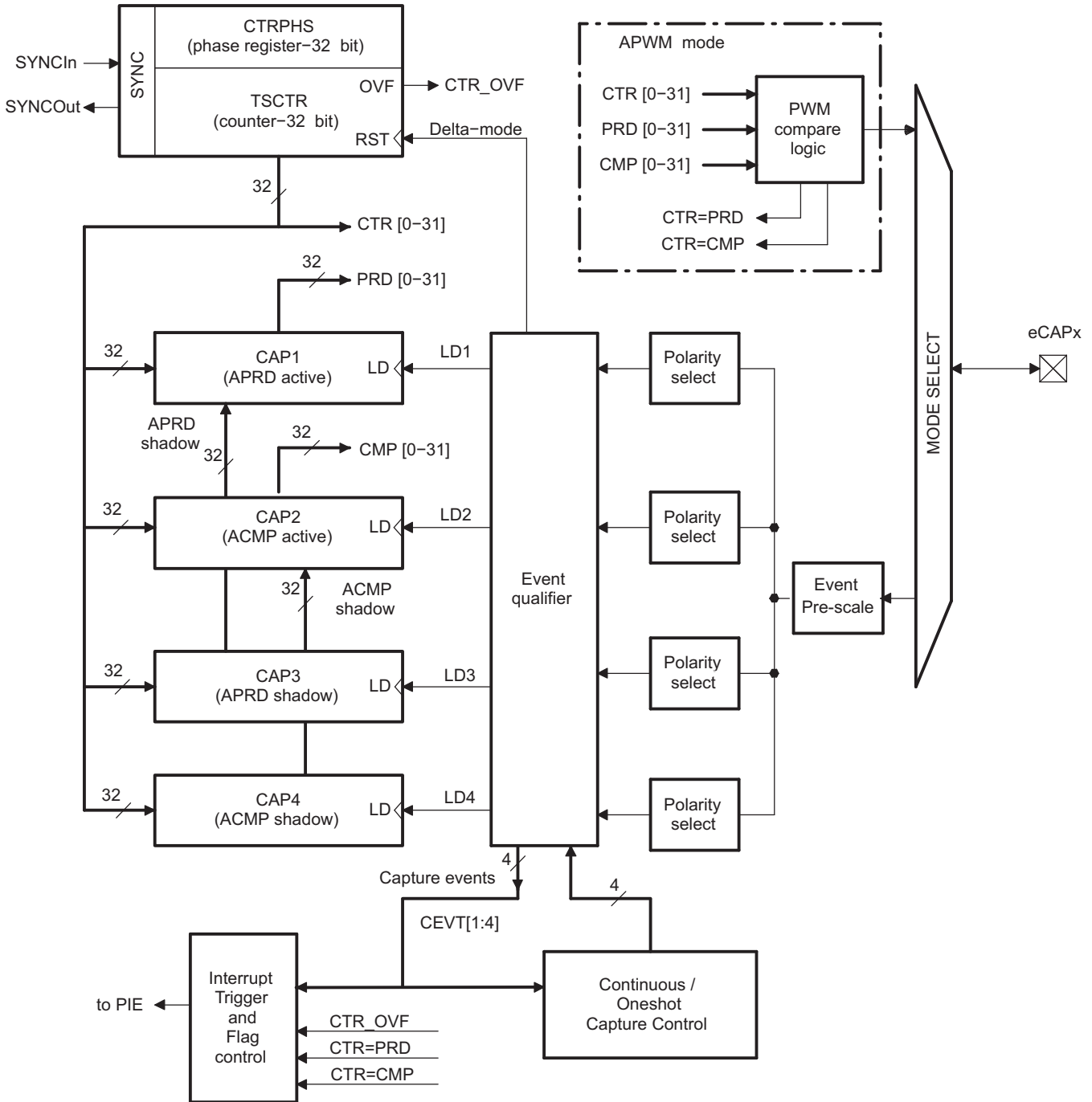

Figure 6-16. eCAP Block Diagram

The eCAP module is clocked at the SYSCLKOUT rate.

The clock enable bits (ECAP1–ECAP6) in the PCLKCR3 register turn off the eCAP module individually (for low-power operation). Upon reset, ECAP1ENCLK is set to low, indicating that the peripheral clock is off.

6.6.2.5 Enhanced Quadrature Encoder Pulse

Figure 6-17 shows the eQEP block diagram.

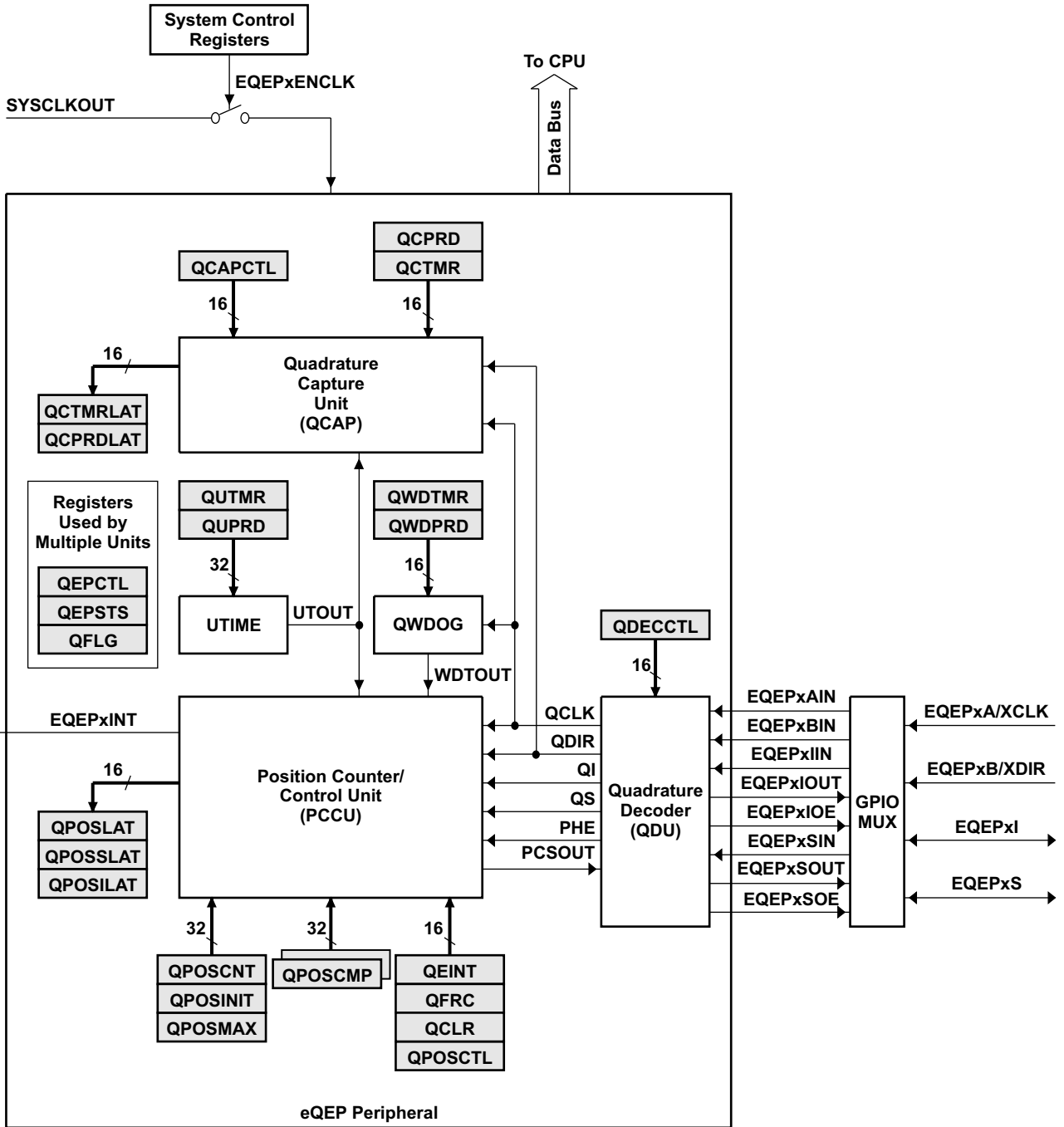

Figure 6-17. eQEP Block Diagram

ADVANCE INFORMATION

6.6.3 Communications Peripherals

6.6.3.1 Serial Peripheral Interface

The SPI is a high-speed synchronous serial input/output (I/O) port that allows a serial bit stream of programmed length (1 to 16 bits) to be shifted into and out of the device at a programmed bit-transfer rate. The SPI is normally used for communications between the microcontroller and external peripherals or another controller. Typical applications include external I/O or peripheral expansion via devices such as shift registers, display drivers, and ADCs. Multi-device communications are supported by the master/slave operation of the SPI. The port supports 16-level receive and transmit FIFOs for reducing CPU servicing overhead.

The SPI module features include:

- SPISOMI: SPI slave-output/master-input pin
- SPISIMO: SPI slave-input/master-output pin
- SPISTE: SPI slave transmit-enable pin
- SPICLK: SPI serial-clock pin
- Two operational modes: master and slave
- Baud rate: 125 different programmable rates
- Data word length: 1 to 16 data bits
- Four clocking schemes (controlled by clock polarity and clock phase bits) include:
 - Falling edge without phase delay: SPICLK active-high. SPI transmits data on the falling edge of the SPICLK signal and receives data on the rising edge of the SPICLK signal.
 - Falling edge with phase delay: SPICLK active-high. SPI transmits data one half-cycle ahead of the falling edge of the SPICLK signal and receives data on the falling edge of the SPICLK signal.
 - Rising edge without phase delay: SPICLK inactive-low. SPI transmits data on the rising edge of the SPICLK signal and receives data on the falling edge of the SPICLK signal.
 - Rising edge with phase delay: SPICLK inactive-low. SPI transmits data one half-cycle ahead of the falling edge of the SPICLK signal and receives data on the rising edge of the SPICLK signal.
- Simultaneous receive-and-transmit operation (transmit function can be disabled in software)
- Transmitter and receiver operations are accomplished through either interrupt-driven or polled algorithms.
- 16-level transmit and receive FIFO
- Delayed transmit control

The SPI operates in master or slave mode. The master initiates data transfer by sending the SPICLK signal. For both the slave and the master, data is shifted out of the shift registers on one edge of the SPICLK and latched into the shift register on the opposite SPICLK clock edge. If the CLOCK PHASE bit (SPICTL.3) is high, data is transmitted and received a half-cycle before the SPICLK transition. As a result, both controllers send and receive data simultaneously. The application software determines whether the data is meaningful or dummy data. There are three possible methods for data transmission:

- Master sends data; slave sends dummy data
- Master sends data; slave sends data
- Master sends dummy data; slave sends data

The master can initiate a data transfer at any time because it controls the SPICLK signal. The software, however, determines how the master detects when the slave is ready to broadcast data.

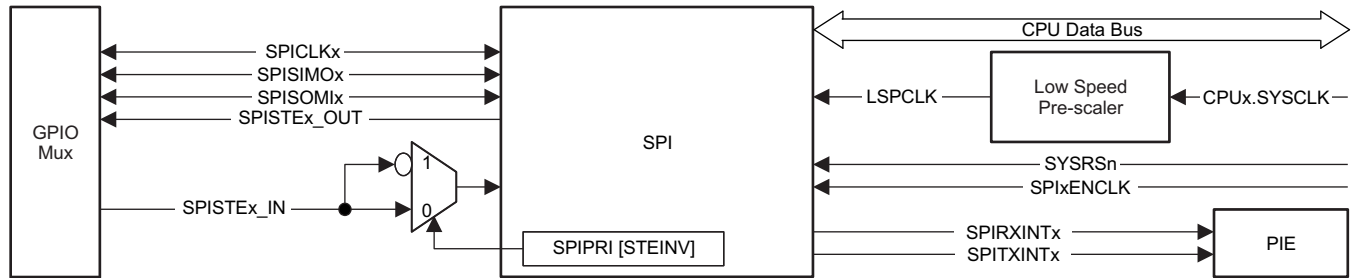

Figure 6-18. SPI

ADVANCE INFORMATION

6.6.3.2 Serial Communications Interface

The SCI is a two-wire asynchronous serial port, commonly known as a UART. The SCI module supports digital communications between the CPU and other asynchronous peripherals that use the standard non-return-to-zero (NRZ) format

The SCI receiver and transmitter each have a 16-level-deep FIFO for reducing servicing overhead, and each has its own separate enable and interrupt bits. Both can be operated independently for half-duplex communication, or simultaneously for full-duplex communication. To specify data integrity, the SCI checks received data for break detection, parity, overrun, and framing errors. The bit rate is programmable to different speeds through a 16-bit baud-select register.

Features of the SCI module include:

- Two external pins:
 - SCITXD: SCI transmit-output pin
 - SCIRXD: SCI receive-input pin
 - NOTE:** Both pins can be used as GPIO if not used for SCI.
 - Baud rate programmable to 64K different rates
- Data-word format
 - One start bit
 - Data-word length programmable from one to eight bits
 - Optional even/odd/no parity bit
 - One or two stop bits
- Four error-detection flags: parity, overrun, framing, and break detection
- Two wake-up multiprocessor modes: idle-line and address bit
- Half- or full-duplex operation
- Double-buffered receive and transmit functions
- Transmitter and receiver operations can be accomplished through interrupt-driven or polled algorithms with status flags.
 - Transmitter: TXRDY flag (transmitter-buffer register is ready to receive another character) and TX EMPTY flag (transmitter-shift register is empty)
 - Receiver: RXRDY flag (receiver-buffer register is ready to receive another character), BRKDT flag (break condition occurred), and RX ERROR flag (monitoring four interrupt conditions)
- Separate enable bits for transmitter and receiver interrupts (except BRKDT)
- NRZ (non-return-to-zero) format
- Auto baud-detect hardware logic
- 16-level transmit and receive FIFO

NOTE

All registers in this module are 8-bit registers. When a register is accessed, the register data is in the lower byte (bits 7–0), and the upper byte (bits 15–8) is read as zeros. Writing to the upper byte has no effect.

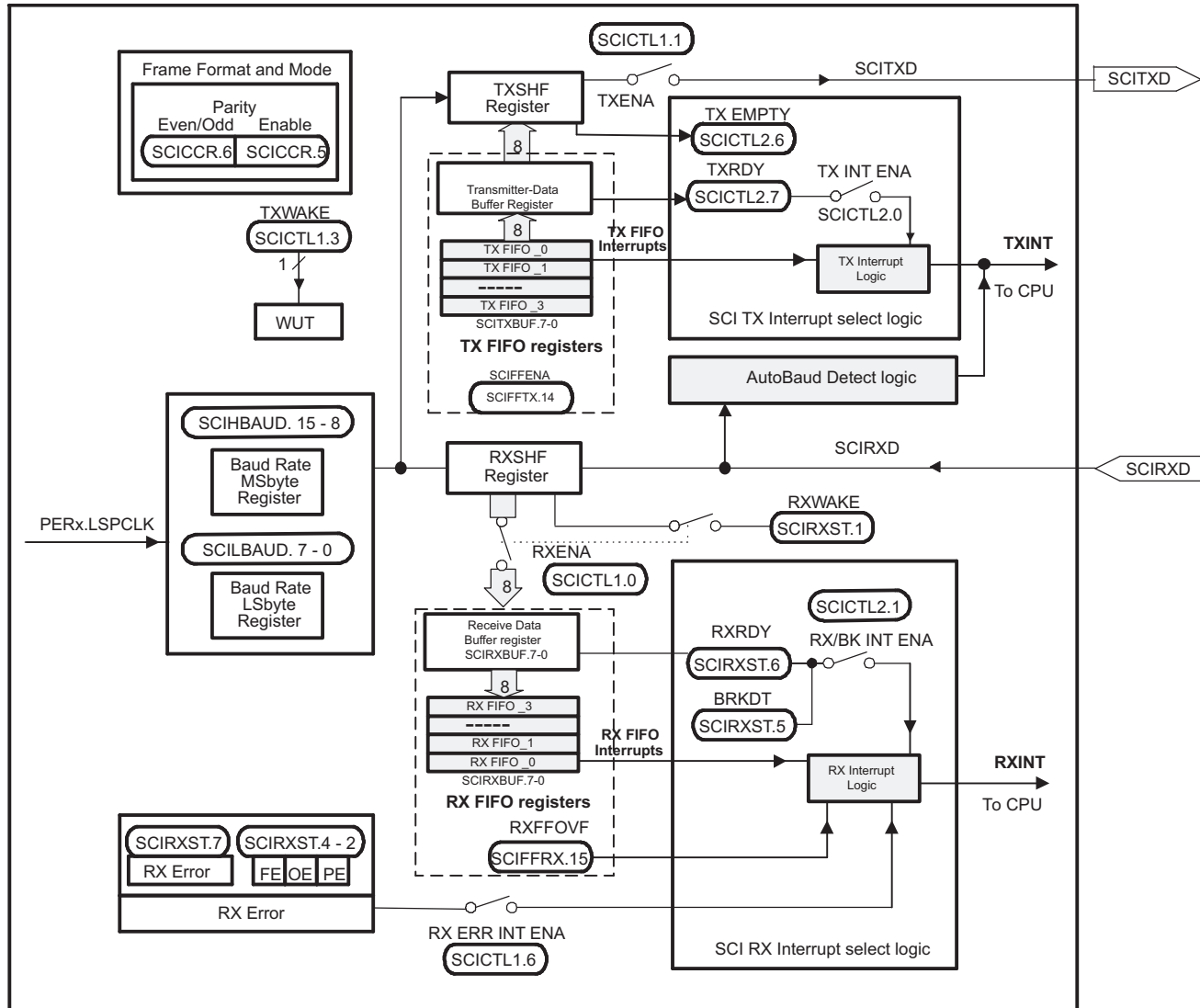

Figure 6-19. SCI Block Diagram

The major elements used in full-duplex operation include:

- A transmitter (TX) and its major registers:
 - SCITXBUF register – Transmitter Data Buffer register. Contains data (loaded by the CPU) to be transmitted
 - TXSHF register – Transmitter Shift register. Accepts data from the SCITXBUF register and shifts data onto the SCITXD pin, one bit at a time
- A receiver (RX) and its major registers:
 - RXSHF register – Receiver Shift register. Shifts data in from the SCIRXD pin, one bit at a time
 - SCIRXBUF register – Receiver Data Buffer register. Contains data to be read by the CPU. Data from a remote processor is loaded into the RXSHF register and then into the SCIRXBUF and SCIRXEMU registers
- A programmable baud generator
- Data-memory-mapped control and status registers enable the CPU to access the I²C module registers and FIFOs.

The SCI receiver and transmitter operate independently.

6.6.3.3 Inter-Integrated Circuit

The I²C module has the following features:

- Compliance with the Philips Semiconductors I²C-bus specification (version 2.1):
 - Support for 1-bit to 8-bit format transfers
 - 7-bit and 10-bit addressing modes
 - General call
 - START byte mode
 - Support for multiple master-transmitters and slave-receivers
 - Support for multiple slave-transmitters and master-receivers
 - Combined master transmit/receive and receive/transmit mode
 - Data transfer rate of from 10 kbps up to 400 kbps (I²C Fast-mode rate)
- One 4-word receive FIFO and one 4-word transmit FIFO
- One interrupt that can be used by the CPU. This interrupt can be generated as a result of one of the following conditions:
 - Transmit-data ready
 - Receive-data ready
 - Register-access ready
 - No-acknowledgment received
 - Arbitration lost
 - Stop condition detected
 - Addressed as slave
- An additional interrupt that can be used by the CPU when in FIFO mode
- Module enable/disable capability
- Free data format mode

Figure 6-20 shows how the I²C peripheral module interfaces within the device.

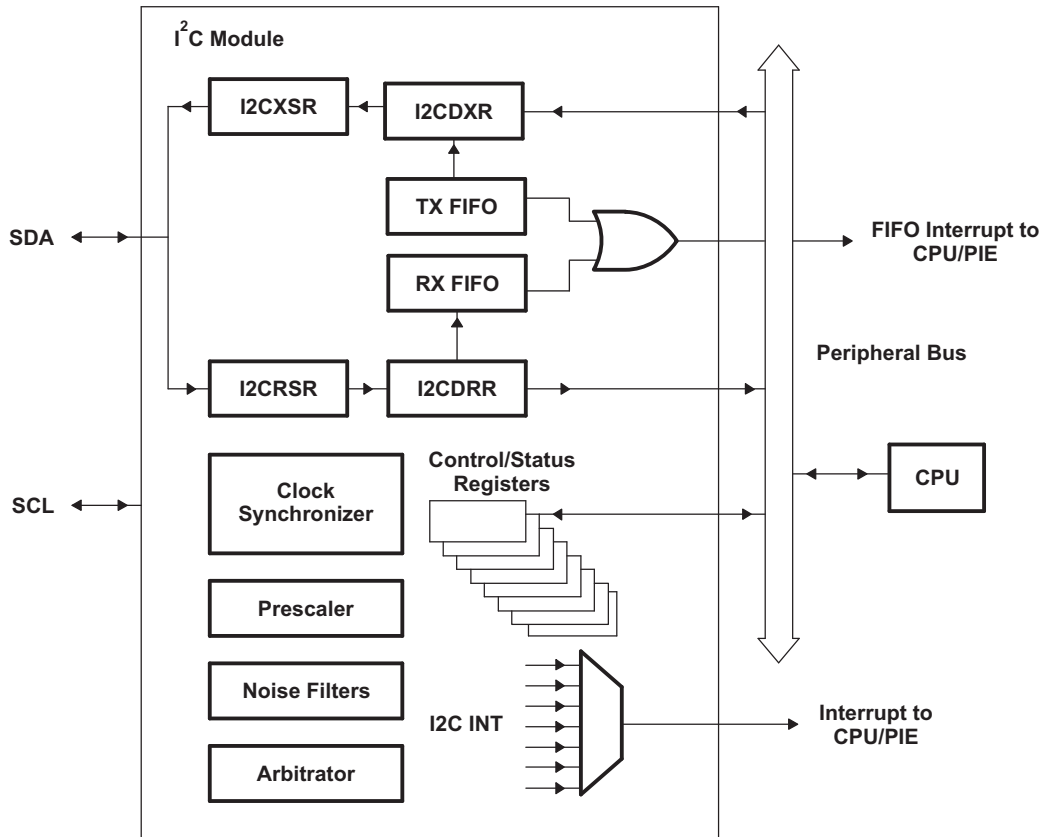

Figure 6-20. I²C Peripheral Module Interfaces

6.6.3.4 Multichannel Buffered Serial Port

The McBSP module has the following features:

- Compatible to McBSP in TMS320C28x/TMS320F28x DSP devices
- Full-duplex communication
- Double-buffered data registers that allow a continuous data stream
- Independent framing and clocking for receive and transmit
- External shift clock generation or an internal programmable frequency shift clock
- 8-bit data transfer mode can be configured to transmit with LSB or MSB first
- Programmable polarity for both frame synchronization and data clocks
- Highly programmable internal clock and frame generation
- Direct interface to industry-standard CODECs, Analog Interface Chips (AICs), and other serially connected A/D and D/A devices
- Works with SPI-compatible devices
- The following application interfaces can be supported on the McBSP:
 - T1/E1 framers
 - IOM-2 compliant devices
 - AC97-compliant devices (the necessary multiphase frame synchronization capability is provided.)
 - IIS-compliant devices
 - SPI
- McBSP clock rate,

$$\text{CLKG} = \frac{\text{CLKSRG}}{(1 + \text{CLKGDV})}$$

where CLKSRG source could be LSPCLK, CLKX, or CLKR. Serial port performance is limited by I/O buffer switching speed. Internal prescalers must be adjusted such that the peripheral speed is less than the I/O buffer speed limit.

Figure 6-21 shows the block diagram of the McBSP module.

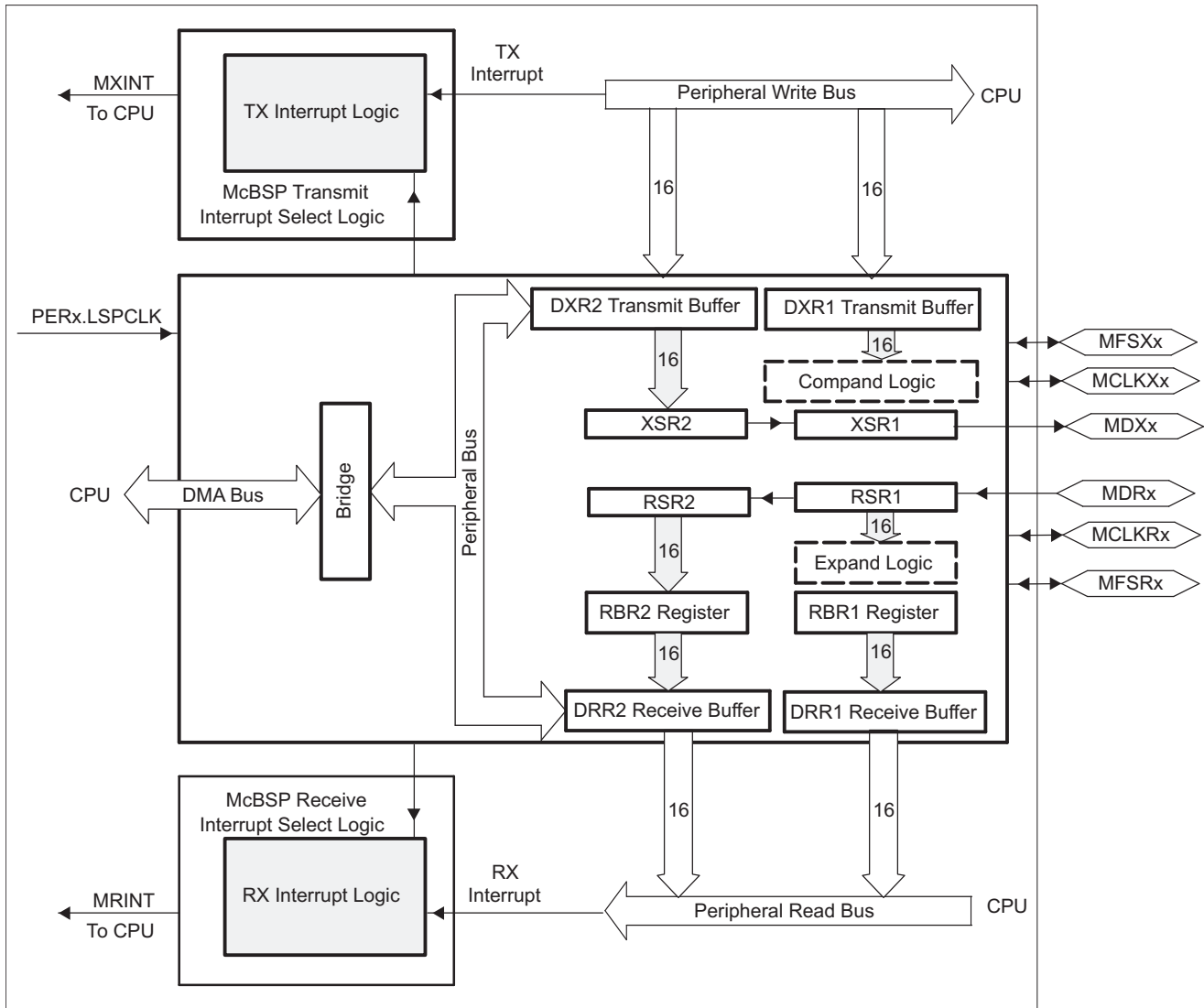

Figure 6-21. McBSP Block Diagram

ADVANCE INFORMATION

6.6.3.5 Universal Serial Bus Controller

The USB controller operates as a full-speed or low-speed function controller during point-to-point communications with USB host or device functions.

The USB module has the following features:

- USB 2.0 full-speed (12 Mbps) and low-speed (1.5 Mbps) operation
- Integrated PHY
- Four transfer types: control, interrupt, bulk, and isochronous
- 32 endpoints
 - One dedicated control IN endpoint and one dedicated control OUT endpoint
 - 15 configurable IN endpoints and 15 configurable OUT endpoints
- Four KB dedicated endpoint memory: one endpoint may be defined for double-buffered 1023-byte isochronous packet size
- Efficient transfers using DMA controller
 - Separate channels for transmit and receive for up to three IN endpoints and three OUT endpoints
 - Channel requests asserted when FIFO contains required amount of data

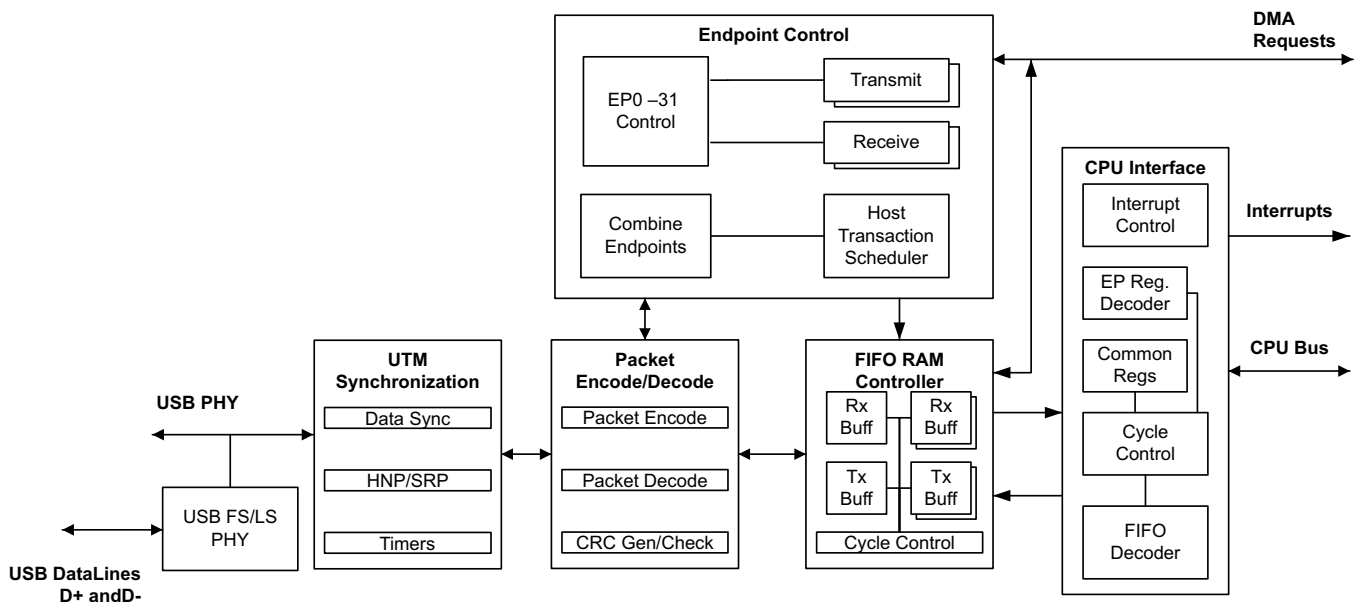

Figure 6-22. USB Block Diagram

ADVANCE INFORMATION

6.6.3.6 Controller Area Network

The CAN module has the following features:

- Fully compliant with CAN protocol, version 2.0B
- Supports data rates up to 1 Mbps
- Thirty-two mailboxes, each with the following properties:
 - Configurable as receive or transmit
 - Configurable with standard or extended identifier
 - Has a programmable receive mask
 - Individual identifier mask for each message object
 - Supports data and remote frame
 - Composed of 0 to 8 bytes of data
 - Uses a 32-bit time stamp on receive and transmit message
 - Protects against reception of new message
 - Holds the dynamically programmable priority of transmit message
 - Employs a programmable interrupt scheme with two interrupt levels
 - Employs a programmable alarm on transmission or reception time-out
 - Programmable FIFO mode for message objects
 - Message RAM parity check mechanism
- Low-power mode
- Programmable wake-up on bus activity
- Automatic reply to a remote request message
- Automatic retransmission of a frame in case of loss of arbitration or error
- 32-bit local network time counter synchronized by a specific message (communication in conjunction with mailbox 16)
- Self-test mode
 - Operates in a loopback mode receiving its own message. A "dummy" acknowledge is provided, thereby eliminating the need for another node to provide the acknowledge bit.

NOTE

For a CANx Bit-CLK of 200 MHz, the smallest bit rate possible is 7.8125 kbps.

6.6.3.7 External Memory Interface

This EMIF memory controller is compliant with the JESD21-C SDR SDRAMs utilizing a 32-bit/16-bit data bus. The purpose of this EMIF is to provide a means for the CPU to connect to a variety of external devices.

6.6.3.7.1 Asynchronous Memory Support

The EMIF supports asynchronous memories:

- SRAMs
- NOR Flash memories

There is an external wait input that allows slower asynchronous memories to extend the memory access. The EMIF module supports up to three chip selects ($\overline{\text{EMIF_CS}}[4:2]$). Each chip select has the following individually programmable attributes:

- Data bus width
- Read cycle timings: setup, hold, strobe
- Write cycle timings: setup, hold, strobe
- Bus turnaround time
- Extended wait option with programmable timeout
- Select strobe option

6.6.3.7.2 Synchronous DRAM Support

The EMIF module supports 16-bit/32-bit synchronous DRAM (SDRAM), it has a single SDRAM chip select ($\overline{\text{EMIF_CS}}[0]$). SDRAM configurations supported are:

- One-bank, two-bank, and four-bank SDRAM devices
- Devices with eight, nine, ten, and eleven column addresses
- CAS latency of two or three clock cycles
- 16-bit/32-bit data bus width
- 3.3-V LVCMOS interface

Additionally, the EMIF supports placing the SDRAM in self-refresh and power-down modes. Self-refresh mode allows the SDRAM to be put in a low-power state while still retaining memory contents; since the SDRAM will continue to refresh itself even without clocks from the microcontroller. Power-down mode achieves even lower power, except the microcontroller must periodically wake up and issue refreshes if data retention is required. Note that the EMIF module does not support mobile SDRAM devices.

7 Device and Documentation Support

7.1 Device Support

7.1.1 Development Support

Texas Instruments (TI) offers an extensive line of development tools for the C28x family of MCUs, including tools to evaluate the performance of the processors, generate code, develop algorithm implementations, and fully integrate and debug software and hardware modules.

The following products support development:

Software Development Tools

- Code Composer Studio Integrated Development Environment (IDE)
 - C/C++ Compiler
 - Code generation tools
 - Assembler/Linker
 - Cycle Accurate Simulator
- Application algorithms
- Sample applications code

Hardware Development Tools

- Development and evaluation boards
- JTAG-based emulators - XDS510™ class, XDS560™ emulator, XDS100v2, XDS200
- Flash programming tools

For a complete listing of development-support tools for the processor platform, visit the Texas Instruments website at www.ti.com. For technical questions, visit <http://e2e.ti.com>. For information on pricing and availability, contact the nearest TI field sales office or authorized distributor.

7.1.2 Device and Development Support Tool Nomenclature

To designate the stages in the product development cycle, TI assigns prefixes to the part numbers of all TMS320™ MCU devices and support tools. Each TMS320 MCU commercial family member has one of three prefixes: TMX, TMP, or TMS (for example, **TMS320F28377D**). Texas Instruments recommends two of three possible prefix designators for its support tools: TMDX and TMDS. These prefixes represent evolutionary stages of product development from engineering prototypes (with TMX for devices and TMDX for tools) through fully qualified production devices and tools (with TMS for devices and TMDS for tools).

Device development evolutionary flow:

- | | |
|------------|--|
| TMX | Experimental device that is not necessarily representative of the final device's electrical specifications |
| TMP | Final silicon die that conforms to the device's electrical specifications but has not completed quality and reliability verification |
| TMS | Fully qualified production device |

Support tool development evolutionary flow:

- | | |
|-------------|---|
| TMDX | Development-support product that has not yet completed Texas Instruments internal qualification testing |
| TMDS | Fully qualified development-support product |

TMX and TMP devices and TMDX development-support tools are shipped against the following disclaimer:

"Developmental product is intended for internal evaluation purposes."

TMS devices and TMDS development-support tools have been characterized fully, and the quality and reliability of the device have been demonstrated fully. TI's standard warranty applies.

Predictions show that prototype devices (TMX or TMP) have a greater failure rate than the standard production devices. Texas Instruments recommends that these devices not be used in any production system because their expected end-use failure rate still is undefined. Only qualified production devices are to be used.

TI device nomenclature also includes a suffix with the device family name. This suffix indicates the package type (for example, PTP) and temperature range (for example, S). [Figure 7-1](#) provides a legend for reading the complete device name for any family member.

For device part numbers and further ordering information, see the TI website (www.ti.com) or contact your TI sales representative.

For additional description of the device nomenclature markings on the die, see the *TMS320F28377D, TMS320F28376D, TMS320F28375D, TMS320F28374D Delfino Microcontrollers Silicon Errata* (literature number [SPRZ412](#)).

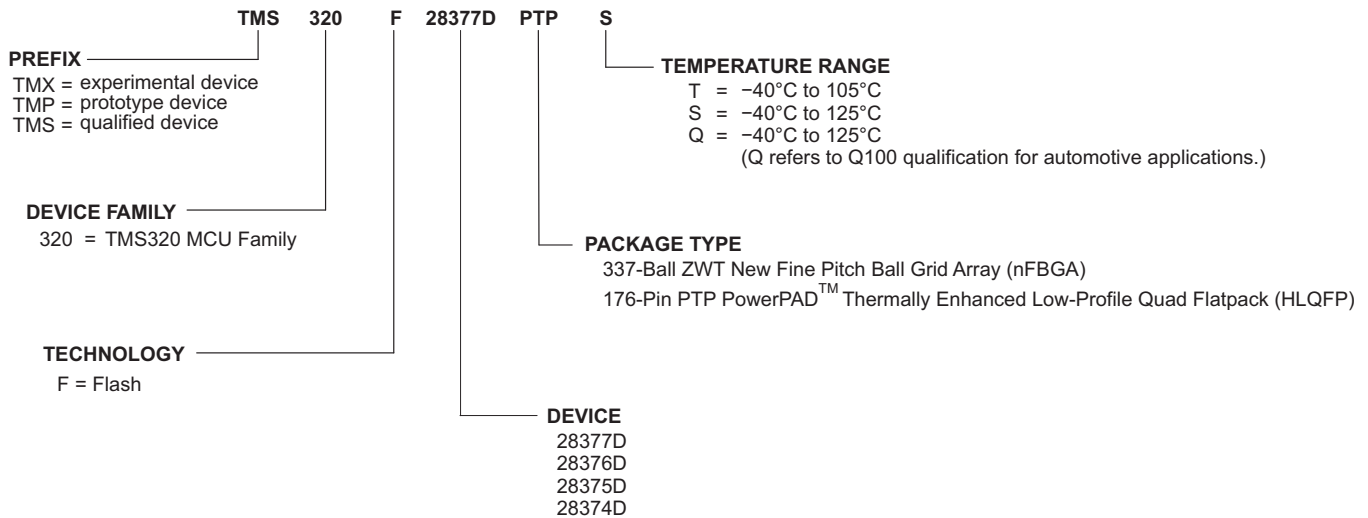

Figure 7-1. Device Nomenclature

ADVANCE INFORMATION

7.2 Documentation Support

Extensive documentation supports all of the TMS320 MCU family generations of devices from product announcement through applications development. The types of documentation available include: data sheets and data manuals, with design specifications; and hardware and software applications.

The following documents can be downloaded from the TI website (www.ti.com):

Data Manual and Errata

[SPRS880](#) **TMS320F28377D, TMS320F28376D, TMS320F28375D, TMS320F28374D Dual-Core Delfino™ Microcontrollers Data Manual** contains the pinout, signal descriptions, as well as electrical and timing specifications for the 2837xD devices.

[SPRZ412](#) **TMS320F28377D, TMS320F28376D, TMS320F28375D, TMS320F28374D Delfino Microcontrollers Silicon Errata** describes known advisories on silicon and provides workarounds.

Technical Reference Manual

[SPRUHM8](#) **TMS320F2837xD Delfino Microcontrollers Technical Reference Manual** details the integration, the environment, the functional description, and the programming models for each peripheral and subsystem in the 2837xD microcontrollers.

CPU User's Guides

[SPRU430](#) **TMS320C28x CPU and Instruction Set Reference Guide** describes the central processing unit (CPU) and the assembly language instructions of the TMS320C28x fixed-point digital signal processors (DSPs). This Reference Guide also describes emulation features available on these DSPs.

[SPRUHS1](#) **TMS320C28x Extended Instruction Sets Reference Guide** describes the architecture, pipeline, and instruction set of the TMU, VCU-II, and FPU accelerators.

Peripheral Guides

[SPRU566](#) **TMS320x28xx, 28xxx DSP Peripheral Reference Guide** describes the peripheral reference guides of the 28x DSPs.

Tools Guides

[SPRU513](#) **TMS320C28x Assembly Language Tools v6.2.4 User's Guide** describes the assembly language tools (assembler and other tools used to develop assembly language code), assembler directives, macros, common object file format, and symbolic debugging directives for the TMS320C28x device.

[SPRU514](#) **TMS320C28x Optimizing C/C++ Compiler v6.2.4 User's Guide** describes the TMS320C28x C/C++ compiler. This compiler accepts ANSI standard C/C++ source code and produces TMS320 DSP assembly language source code for the TMS320C28x device.

[SPRU608](#) **TMS320C28x Instruction Set Simulator Technical Overview** describes the simulator, available within the Code Composer Studio for TMS320C2000 IDE, that simulates the instruction set of the C28x core.

7.3 Related Links

The table below lists quick access links. Categories include technical documents, support and community resources, tools and software, and quick access to sample or buy.

Table 7-1. Related Links

PARTS	PRODUCT FOLDER	SAMPLE & BUY	TECHNICAL DOCUMENTS	TOOLS & SOFTWARE	SUPPORT & COMMUNITY
TMS320F28377D	Click here	Click here	Click here	Click here	Click here
TMS320F28376D	Click here	Click here	Click here	Click here	Click here
TMS320F28375D	Click here	Click here	Click here	Click here	Click here
TMS320F28374D	Click here	Click here	Click here	Click here	Click here

7.4 Community Resources

The following links connect to TI community resources. Linked contents are provided "AS IS" by the respective contributors. They do not constitute TI specifications and do not necessarily reflect TI's views; see TI's [Terms of Use](#).

[TI E2E Community](#) *TI's Engineer-to-Engineer (E2E) Community*. Created to foster collaboration among engineers. At e2e.ti.com, you can ask questions, share knowledge, explore ideas and help solve problems with fellow engineers.

[TI Embedded Processors Wiki](#) *Texas Instruments Embedded Processors Wiki*. Established to help developers get started with Embedded Processors from Texas Instruments and to foster innovation and growth of general knowledge about the hardware and software surrounding these devices.

7.5 Trademarks

Delfino, Code Composer Studio, DSP/BIOS, PowerPAD, C2000, XDS510, XDS560, TMS320 are trademarks of Texas Instruments. All other trademarks are the property of their respective owners.

7.6 Electrostatic Discharge Caution



This integrated circuit can be damaged by ESD. Texas Instruments recommends that all integrated circuits be handled with appropriate precautions. Failure to observe proper handling and installation procedures can cause damage.

ESD damage can range from subtle performance degradation to complete device failure. Precision integrated circuits may be more susceptible to damage because very small parametric changes could cause the device not to meet its published specifications.

7.7 Glossary

[SLYZ022](#) — *TI Glossary*.

This glossary lists and explains terms, acronyms and definitions.

8 Mechanical Packaging and Orderable Information

8.1 Packaging Information

The following pages include mechanical packaging and orderable information. This information is the most current data available for the designated devices. This data is subject to change without notice and revision of this document. For browser-based versions of this data sheet, refer to the left-hand navigation.

ZWT (S-PBGA-N337)

PLASTIC BALL GRID ARRAY

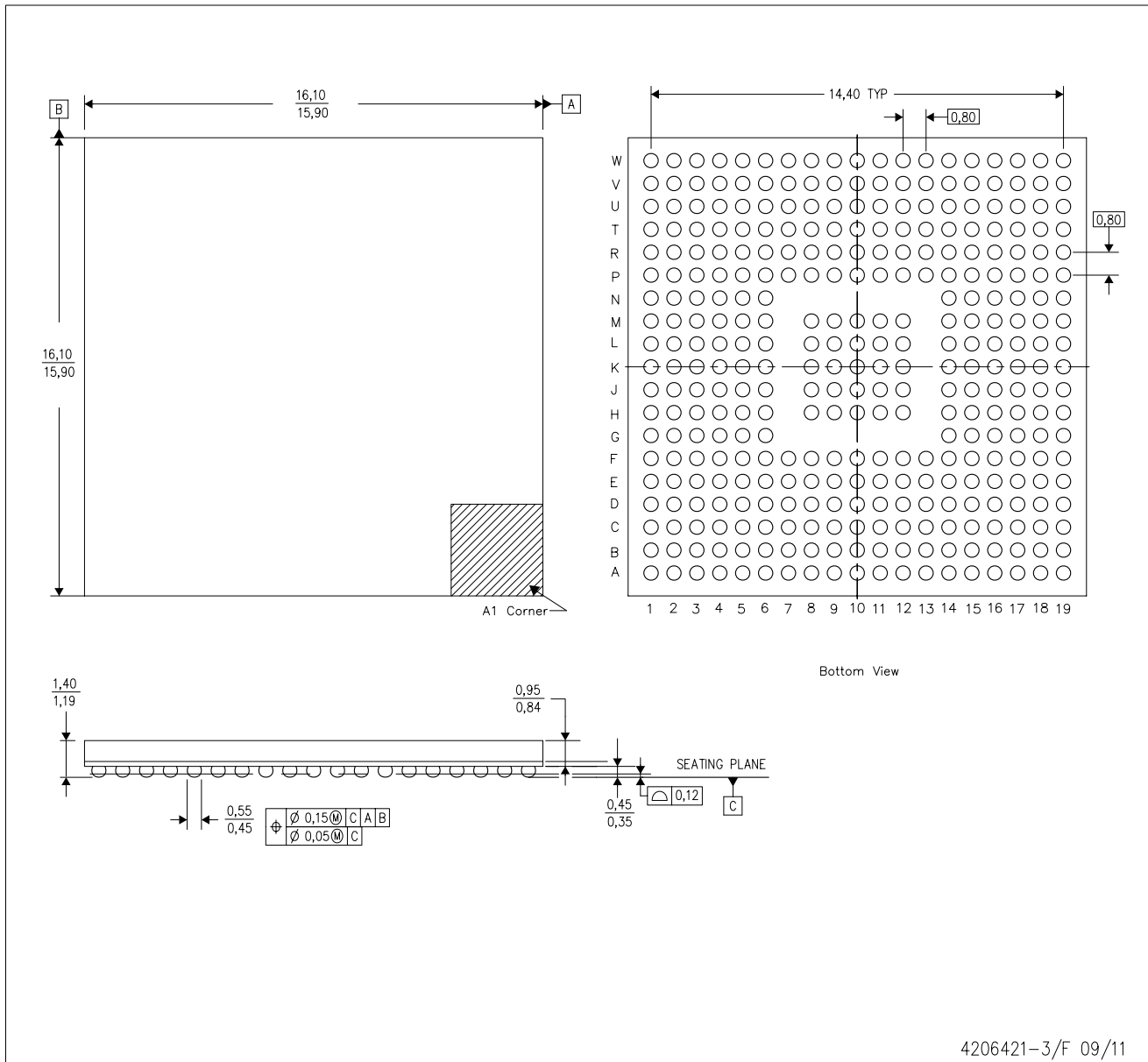

- NOTES:
- A. All linear dimensions are in millimeters. Dimensioning and tolerancing per ASME Y14.5M-1994.
 - B. This drawing is subject to change without notice.
 - C. This is a Pb-free solder ball design.
 - D. Falls within JEDEC MO-275.

PTP (S-PQFP-G176)

PowerPAD™ PLASTIC QUAD FLATPACK

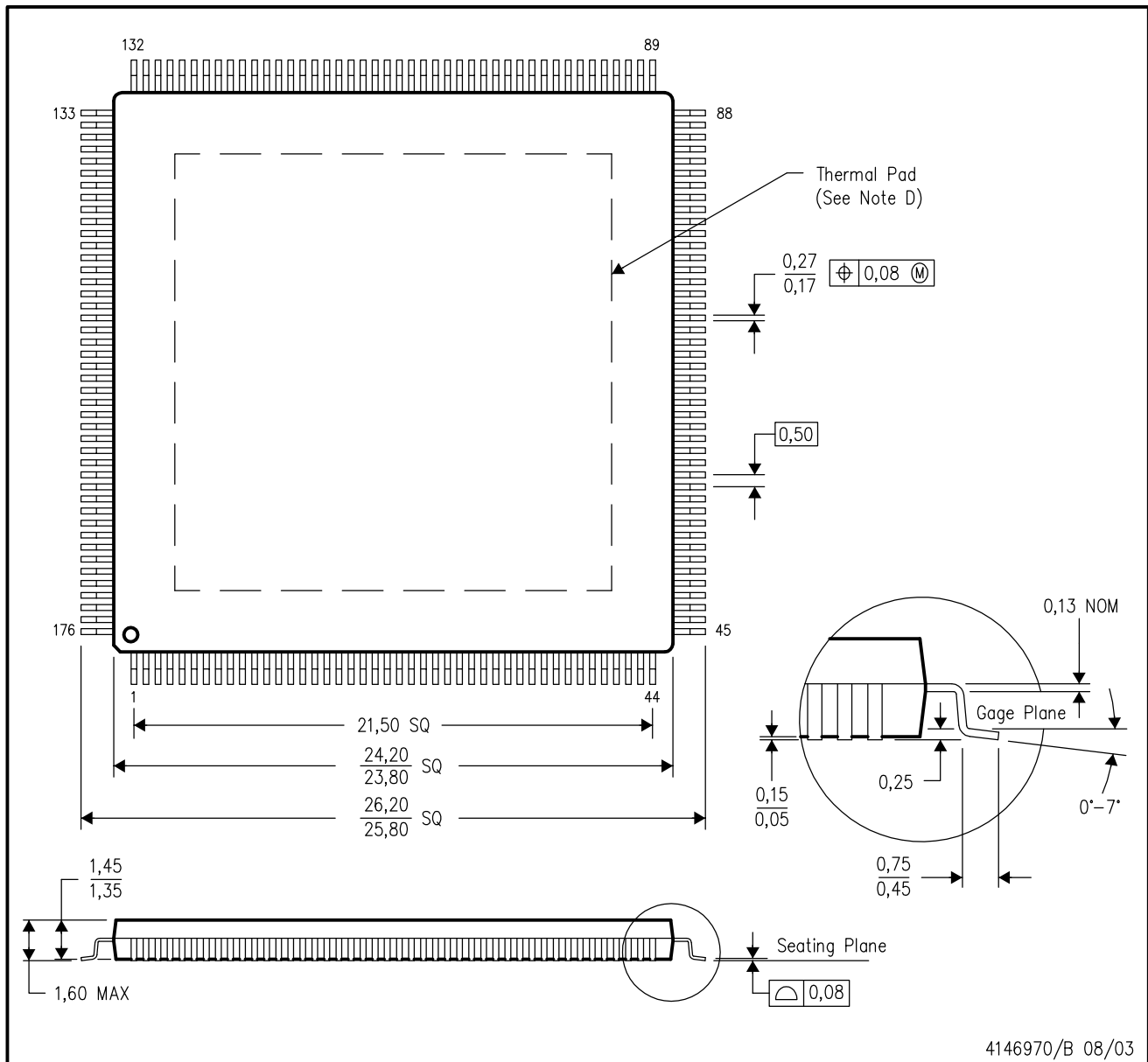

- NOTES:
- A. All linear dimensions are in millimeters.
 - B. This drawing is subject to change without notice.
 - C. Body dimensions do not include mold flash or protrusion.
 - D. This package is designed to be soldered to a thermal pad on the board. Refer to Technical Brief, PowerPad Thermally Enhanced Package, Texas Instruments Literature No. SLMA002 for information regarding recommended board layout. This document is available at www.ti.com <<http://www.ti.com>>.
 - E. Falls within JEDEC MO-026

PowerPAD is a trademark of Texas Instruments.

PTP (S-PQFP-G176)

PowerPAD™ PLASTIC QUAD FLATPACK

THERMAL INFORMATION

This PowerPAD™ package incorporates an exposed thermal pad that is designed to be attached to a printed circuit board (PCB). The thermal pad must be soldered directly to the PCB. After soldering, the PCB can be used as a heatsink. In addition, through the use of thermal vias, the thermal pad can be attached directly to the appropriate copper plane shown in the electrical schematic for the device, or alternatively, can be attached to a special heatsink structure designed into the PCB. This design optimizes the heat transfer from the integrated circuit (IC).

For additional information on the PowerPAD package and how to take advantage of its heat dissipating abilities, refer to Technical Brief, PowerPAD Thermally Enhanced Package, Texas Instruments Literature No. SLMA002 and Application Brief, PowerPAD Made Easy, Texas Instruments Literature No. SLMA004. Both documents are available at www.ti.com.

The exposed thermal pad dimensions for this package are shown in the following illustration.

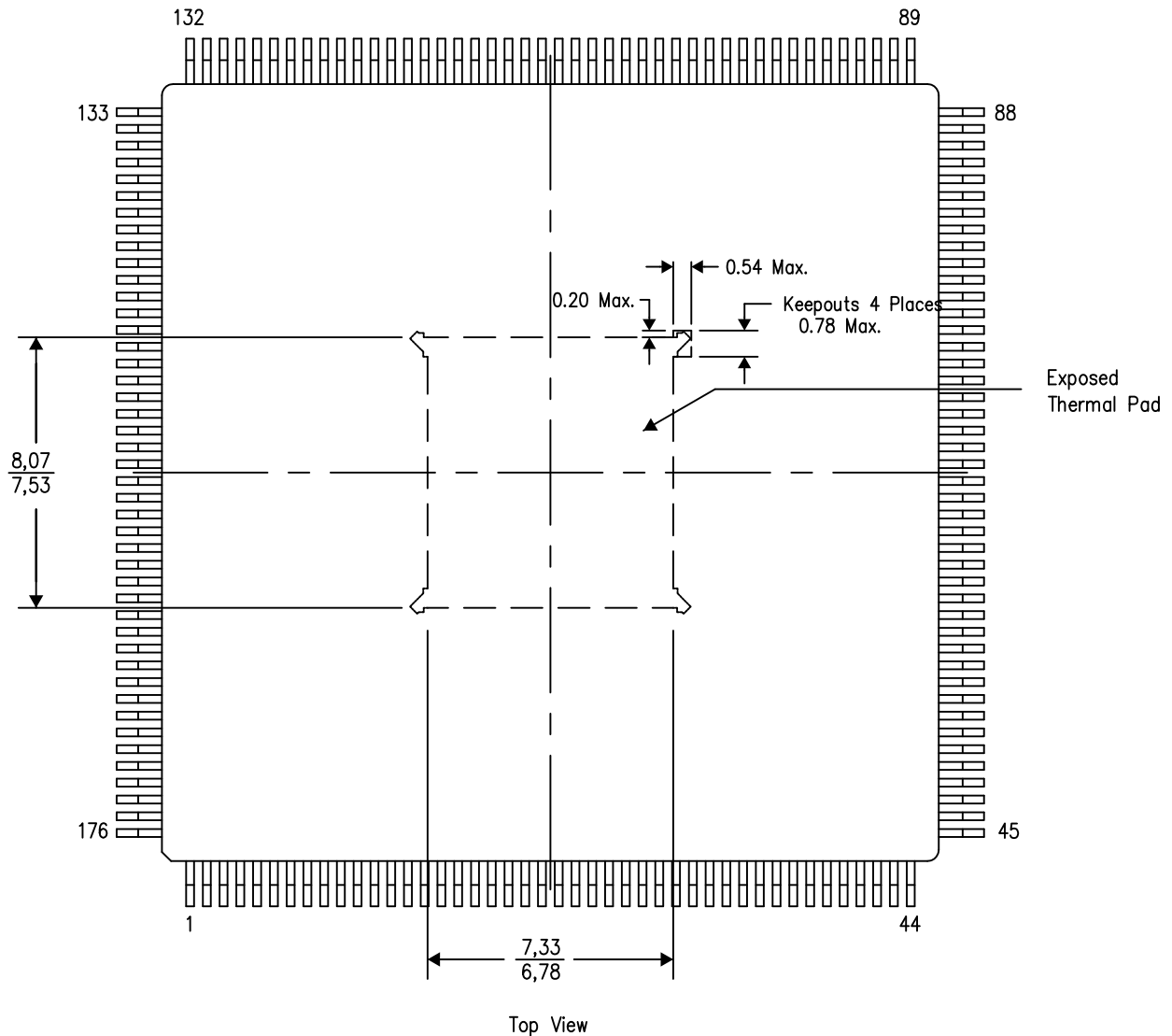

Exposed Thermal Pad Dimensions

4209350-8/F 04/13

NOTE: All linear dimensions are in millimeters

NOTE: Keep-out features are identified to prevent board routing interference. These exposed metal features may vary within the identified area or be completely absent on some devices.

PowerPAD is a trademark of Texas Instruments

PACKAGING INFORMATION

Orderable Device	Status (1)	Package Type	Package Drawing	Pins	Package Qty	Eco Plan (2)	Lead/Ball Finish (6)	MSL Peak Temp (3)	Op Temp (°C)	Device Marking (4/5)	Samples
TMS320F28376DPTPS	PREVIEW	HLQFP	PTP	176	40	TBD	Call TI	Call TI	-40 to 125		
TMS320F28376DPTPT	PREVIEW	HLQFP	PTP	176	40	TBD	Call TI	Call TI	-40 to 105		
TMS320F28376DZWTS	PREVIEW	NFBGA	ZWT	337	90	TBD	Call TI	Call TI	-40 to 125		
TMS320F28376DZWTT	PREVIEW	NFBGA	ZWT	337	90	TBD	Call TI	Call TI	-40 to 105		
TMS320F28377DPTPQ	PREVIEW	HLQFP	PTP	176	40	TBD	Call TI	Call TI	-40 to 125		
TMS320F28377DPTPS	PREVIEW	HLQFP	PTP	176	40	TBD	Call TI	Call TI	-40 to 125		
TMS320F28377DPTPT	PREVIEW	HLQFP	PTP	176	40	TBD	Call TI	Call TI	-40 to 105		
TMS320F28377DZWTQ	PREVIEW	NFBGA	ZWT	337	90	TBD	Call TI	Call TI	-40 to 125		
TMS320F28377DZWTS	PREVIEW	NFBGA	ZWT	337	90	TBD	Call TI	Call TI	-40 to 105		
TMS320F28377DZWTT	PREVIEW	NFBGA	ZWT	337	90	TBD	Call TI	Call TI	-40 to 105		
TMX320F28377DPTPT	ACTIVE	HLQFP	PTP	176	1	TBD	Call TI	Call TI	-40 to 105		Samples
TMX320F28377DZWTT	ACTIVE	NFBGA	ZWT	337	1	TBD	Call TI	Call TI	-40 to 105		Samples

(1) The marketing status values are defined as follows:

ACTIVE: Product device recommended for new designs.

LIFEBUY: TI has announced that the device will be discontinued, and a lifetime-buy period is in effect.

NRND: Not recommended for new designs. Device is in production to support existing customers, but TI does not recommend using this part in a new design.

PREVIEW: Device has been announced but is not in production. Samples may or may not be available.

OBSOLETE: TI has discontinued the production of the device.

(2) Eco Plan - The planned eco-friendly classification: Pb-Free (RoHS), Pb-Free (RoHS Exempt), or Green (RoHS & no Sb/Br) - please check <http://www.ti.com/productcontent> for the latest availability information and additional product content details.

TBD: The Pb-Free/Green conversion plan has not been defined.

Pb-Free (RoHS): TI's terms "Lead-Free" or "Pb-Free" mean semiconductor products that are compatible with the current RoHS requirements for all 6 substances, including the requirement that lead not exceed 0.1% by weight in homogeneous materials. Where designed to be soldered at high temperatures, TI Pb-Free products are suitable for use in specified lead-free processes.

Pb-Free (RoHS Exempt): This component has a RoHS exemption for either 1) lead-based flip-chip solder bumps used between the die and package, or 2) lead-based die adhesive used between the die and leadframe. The component is otherwise considered Pb-Free (RoHS compatible) as defined above.

Green (RoHS & no Sb/Br): TI defines "Green" to mean Pb-Free (RoHS compatible), and free of Bromine (Br) and Antimony (Sb) based flame retardants (Br or Sb do not exceed 0.1% by weight in homogeneous material)

(3) MSL, Peak Temp. - The Moisture Sensitivity Level rating according to the JEDEC industry standard classifications, and peak solder temperature.

(4) There may be additional marking, which relates to the logo, the lot trace code information, or the environmental category on the device.

⁽⁵⁾ Multiple Device Markings will be inside parentheses. Only one Device Marking contained in parentheses and separated by a "~" will appear on a device. If a line is indented then it is a continuation of the previous line and the two combined represent the entire Device Marking for that device.

⁽⁶⁾ Lead/Ball Finish - Orderable Devices may have multiple material finish options. Finish options are separated by a vertical ruled line. Lead/Ball Finish values may wrap to two lines if the finish value exceeds the maximum column width.

Important Information and Disclaimer:The information provided on this page represents TI's knowledge and belief as of the date that it is provided. TI bases its knowledge and belief on information provided by third parties, and makes no representation or warranty as to the accuracy of such information. Efforts are underway to better integrate information from third parties. TI has taken and continues to take reasonable steps to provide representative and accurate information but may not have conducted destructive testing or chemical analysis on incoming materials and chemicals. TI and TI suppliers consider certain information to be proprietary, and thus CAS numbers and other limited information may not be available for release.

In no event shall TI's liability arising out of such information exceed the total purchase price of the TI part(s) at issue in this document sold by TI to Customer on an annual basis.

IMPORTANT NOTICE

Texas Instruments Incorporated and its subsidiaries (TI) reserve the right to make corrections, enhancements, improvements and other changes to its semiconductor products and services per JESD46, latest issue, and to discontinue any product or service per JESD48, latest issue. Buyers should obtain the latest relevant information before placing orders and should verify that such information is current and complete. All semiconductor products (also referred to herein as "components") are sold subject to TI's terms and conditions of sale supplied at the time of order acknowledgment.

TI warrants performance of its components to the specifications applicable at the time of sale, in accordance with the warranty in TI's terms and conditions of sale of semiconductor products. Testing and other quality control techniques are used to the extent TI deems necessary to support this warranty. Except where mandated by applicable law, testing of all parameters of each component is not necessarily performed.

TI assumes no liability for applications assistance or the design of Buyers' products. Buyers are responsible for their products and applications using TI components. To minimize the risks associated with Buyers' products and applications, Buyers should provide adequate design and operating safeguards.

TI does not warrant or represent that any license, either express or implied, is granted under any patent right, copyright, mask work right, or other intellectual property right relating to any combination, machine, or process in which TI components or services are used. Information published by TI regarding third-party products or services does not constitute a license to use such products or services or a warranty or endorsement thereof. Use of such information may require a license from a third party under the patents or other intellectual property of the third party, or a license from TI under the patents or other intellectual property of TI.

Reproduction of significant portions of TI information in TI data books or data sheets is permissible only if reproduction is without alteration and is accompanied by all associated warranties, conditions, limitations, and notices. TI is not responsible or liable for such altered documentation. Information of third parties may be subject to additional restrictions.

Resale of TI components or services with statements different from or beyond the parameters stated by TI for that component or service voids all express and any implied warranties for the associated TI component or service and is an unfair and deceptive business practice. TI is not responsible or liable for any such statements.

Buyer acknowledges and agrees that it is solely responsible for compliance with all legal, regulatory and safety-related requirements concerning its products, and any use of TI components in its applications, notwithstanding any applications-related information or support that may be provided by TI. Buyer represents and agrees that it has all the necessary expertise to create and implement safeguards which anticipate dangerous consequences of failures, monitor failures and their consequences, lessen the likelihood of failures that might cause harm and take appropriate remedial actions. Buyer will fully indemnify TI and its representatives against any damages arising out of the use of any TI components in safety-critical applications.

In some cases, TI components may be promoted specifically to facilitate safety-related applications. With such components, TI's goal is to help enable customers to design and create their own end-product solutions that meet applicable functional safety standards and requirements. Nonetheless, such components are subject to these terms.

No TI components are authorized for use in FDA Class III (or similar life-critical medical equipment) unless authorized officers of the parties have executed a special agreement specifically governing such use.

Only those TI components which TI has specifically designated as military grade or "enhanced plastic" are designed and intended for use in military/aerospace applications or environments. Buyer acknowledges and agrees that any military or aerospace use of TI components which have **not** been so designated is solely at the Buyer's risk, and that Buyer is solely responsible for compliance with all legal and regulatory requirements in connection with such use.

TI has specifically designated certain components as meeting ISO/TS16949 requirements, mainly for automotive use. In any case of use of non-designated products, TI will not be responsible for any failure to meet ISO/TS16949.

Products

Audio	www.ti.com/audio
Amplifiers	amplifier.ti.com
Data Converters	dataconverter.ti.com
DLP® Products	www.dlp.com
DSP	dsp.ti.com
Clocks and Timers	www.ti.com/clocks
Interface	interface.ti.com
Logic	logic.ti.com
Power Mgmt	power.ti.com
Microcontrollers	microcontroller.ti.com
RFID	www.ti-rfid.com
OMAP Applications Processors	www.ti.com/omap
Wireless Connectivity	www.ti.com/wirelessconnectivity

Applications

Automotive and Transportation	www.ti.com/automotive
Communications and Telecom	www.ti.com/communications
Computers and Peripherals	www.ti.com/computers
Consumer Electronics	www.ti.com/consumer-apps
Energy and Lighting	www.ti.com/energy
Industrial	www.ti.com/industrial
Medical	www.ti.com/medical
Security	www.ti.com/security
Space, Avionics and Defense	www.ti.com/space-avionics-defense
Video and Imaging	www.ti.com/video

TI E2E Community

e2e.ti.com