

TMS320C6412 Fixed-Point Digital Signal Processor

Data Manual

Literature Number: SPRS219J
April 2003 – Revised October 2010

PRODUCTION DATA information is current as of publication date. Products conform to specifications per the terms of Texas Instruments standard warranty. Production processing does not necessarily include testing of all parameters.



This page intentionally left blank

Revision History

This data manual revision history highlights the technical changes made to the SPRS219I device-specific data sheet to make it an SPRS219J revision.

| PAGE(s) NO. | ADDS/CHANGES/DELETES |
|----------------|--|
| 101 | Added note for V_{OH} and V_{OL} . |

Contents

| Section | Page |
|---|-----------|
| 1 Features | 14 |
| 1.1 GDK and ZDK BGA Packages (Bottom View) | 15 |
| 1.2 GNZ and ZNZ BGA Packages (Bottom View) | 15 |
| 1.3 Description | 16 |
| 1.4 Device Characteristics | 17 |
| 1.4.1 Device Compatibility | 18 |
| 1.4.2 Functional Block Diagram | 18 |
| 1.4 CPU (DSP Core) Description | 19 |
| 1.6 Memory Map Summary | 22 |
| 1.6.1 L2 Architecture Expanded | 24 |
| 1.7 Peripheral Register Descriptions | 25 |
| 1.8 EDMA Channel Synchronization Events | 39 |
| 1.9 Interrupt Sources and Interrupt Selector | 41 |
| 1.10 Signal Groups Description | 42 |
| | |
| 2 Device Configurations | 47 |
| 2.1 Peripheral Selection at Device Reset | 47 |
| 2.2 Device Configuration at Device Reset | 48 |
| 2.3 Peripheral Selection After Device Reset | 49 |
| 2.4 Peripheral Configuration Lock | 50 |
| 2.5 Device Status Register Description | 52 |
| 2.6 JTAG ID Register Description | 53 |
| 2.7 Multiplexed Pins | 54 |
| 2.8 Debugging Considerations | 54 |
| 2.9 Configuration Examples | 56 |
| 2.10 Terminal Functions | 58 |
| 2.11 Development Support | 81 |
| 2.12 Device Support | 82 |
| 2.12.1 Device and Development-Support Tool Nomenclature | 82 |
| 2.12.2 Documentation Support | 84 |
| 2.13 Clock PLL | 85 |
| 2.14 I2C | 88 |
| 2.15 PCI | 89 |
| 2.16 EMAC | 90 |
| 2.17 MDIO | 91 |
| 2.18 General-Purpose Input/Output (GPIO) | 92 |
| 2.19 Power-Down Modes Logic | 93 |
| 2.19.1 Triggering, Wake-up, and Effects | 93 |
| 2.19.2 C64x Power-Down Mode with an Emulator | 95 |
| 2.20 Power-Supply Sequencing | 96 |
| 2.20.1 Power-Supply Design Considerations | 96 |
| 2.20.2 Power-Supply Decoupling | 96 |
| 2.21 Power-Down Operation | 97 |
| 2.22 IEEE 1149.1 JTAG Compatibility Statement | 97 |
| 2.23 EMIF Device Speed | 98 |
| 2.24 Bootmode | 99 |
| 2.25 Reset | 99 |

| <i>Section</i> | | <i>Page</i> |
|----------------|--|-------------|
| 3 | Electrical Specifications | 100 |
| 3.1 | Absolute Maximum Ratings Over Operating Case Temperature Range (Unless Otherwise Noted)† | 100 |
| 3.2 | Recommended Operating Conditions | 100 |
| 3.3 | Electrical Characteristics Over Recommended Ranges of Supply Voltage and Operating Case Temperature (Unless Otherwise Noted) | 101 |
| 3.4 | Recommended Clock and Control Signal Transition Behavior | 102 |
| 4 | Parameter Information | 102 |
| 4.1 | Signal Transition Levels | 102 |
| 4.2 | Signal Transition Rates | 103 |
| 4.3 | Timing Parameters and Board Routing Analysis | 104 |
| 4.4 | Input and Output Clocks | 105 |
| 5 | Asynchronous Memory Timing | 110 |
| 6 | Programmable Synchronous Interface Timing | 113 |
| 7 | Synchronous DRAM Timing | 117 |
| 8 | HOLD/HOLDA Timing | 123 |
| 9 | BUSREQ Timing | 124 |
| 10 | Reset Timing | 125 |
| 11 | External Interrupt Timing | 127 |
| 12 | Inter-Integrated Circuits (I2C) Timing | 128 |
| 13 | Host-Port Interface (HPI) Timing | 130 |
| 14 | Peripheral Component Interconnect (PCI) Timing | 135 |
| 15 | Multichannel Buffered Serial Port (McBSP) Timing | 138 |
| 16 | Ethernet Media Access Controller (EMAC) Timing | 146 |
| 17 | Management Data Input/Output (MDIO) Timing | 148 |

Contents

| <i>Section</i> | <i>Page</i> |
|--|-------------|
| 18 Timer Timing | 149 |
| 19 General-Purpose Input/Output (GPIO) Port Timing | 150 |
| 20 JTAG Test-Port Timing | 151 |
| 21 Mechanical Data | 152 |
| 21.1 Thermal Data | 152 |
| 21.2 Packaging Information | 154 |

List of Figures

| <i>Figure</i> | | <i>Page</i> |
|---------------|---|-------------|
| 1-1 | GDK and ZDK BGA Packages (Bottom View) | 15 |
| 1-2 | GNZ and ZNZ BGA Packages (Bottom View) | 15 |
| 1-3 | Functional Block Diagram | 18 |
| 1-4 | TMS320C64xE CPU (DSP Core) Data Paths | 21 |
| 1-5 | TMS320C6412 L2 Architecture Memory Configuration | 24 |
| 1-6 | CPU and Peripheral Signals | 42 |
| 1-7 | Peripheral Signals | 43 |
| | | |
| 2-1 | Peripheral Configuration Register (PERCFG) [Address Location: 0x01B3F000 – 0x01B3F003] | 49 |
| 2-2 | Peripheral Enable/Disable Flow Diagram | 50 |
| 2-3 | PCFGLOCK Register Diagram [Address Location: 0x01B3 F018] – Read/Write Accesses | 51 |
| 2-4 | Device Status Register (DEVSTAT) Description – 0x01B3 F004 | 52 |
| 2-5 | JTAG ID Register Description – TMS320C6412 Register Value – 0x0007 902F | 53 |
| 2-6 | Configuration Example (2 McBSPs + EMAC + MDIO + I2C0 + EMIF + HPI + 3 Timers) | 57 |
| 2-7 | TMS320C64xE DSP Device Nomenclature (Including the TMS320C6412 Device) | 83 |
| 2-8 | External PLL Circuitry for Either PLL Multiply Modes or x1 (Bypass) Mode | 86 |
| 2-9 | I2C0 Module Block Diagram | 88 |
| 2-10 | GPIO Enable Register (GPEN) [Hex Address: 01B0 0000] | 92 |
| 2-11 | GPIO Direction Register (GPDIR) [Hex Address: 01B0 0004] | 92 |
| 2-12 | Power-Down Mode Logic† | 93 |
| 2-13 | PWRD Field of the CSR Register | 94 |
| 2-14 | Schottky Diode Diagram | 96 |
| | | |
| 4-1 | Test Load Circuit for AC Timing Measurements | 102 |
| 4-2 | Input and Output Voltage Reference Levels for AC Timing Measurements | 102 |
| 4-3 | Rise and Fall Transition Time Voltage Reference Levels | 102 |
| 4-4 | AC Transient Specification Rise Time | 103 |
| 4-5 | AC Transient Specification Fall Time | 103 |
| 4-6 | Board-Level Input/Output Timings | 104 |
| 4-7 | CLKIN Timing | 106 |
| 4-8 | CLKOUT4 Timing | 106 |
| 4-9 | CLKOUT6 Timing | 107 |
| 4-10 | AECLKIN Timing for EMIFA | 108 |
| 4-11 | AECLKOUT1 Timing for EMIFA Module | 108 |
| 4-12 | AECLKOUT2 Timing for the EMIFA Module | 109 |
| | | |
| 5-1 | Asynchronous Memory Read Timing for EMIFA | 111 |
| 5-2 | Asynchronous Memory Write Timing for EMIFA | 112 |

| <i>Figure</i> | <i>Page</i> |
|---|-------------|
| 6-1 Programmable Synchronous Interface Read Timing for EMIFA (With Read Latency = 2) | 114 |
| 6-2 Programmable Synchronous Interface Write Timing for EMIFA (With Write Latency = 0) | 115 |
| 6-3 Programmable Synchronous Interface Write Timing for EMIFA (With Write Latency = 1) | 116 |
| | |
| 7-1 SDRAM Read Command (CAS Latency 3) for EMIFA | 118 |
| 7-2 SDRAM Write Command for EMIFA | 119 |
| 7-3 SDRAM ACTV Command for EMIFA | 120 |
| 7-4 SDRAM DCAB Command for EMIFA | 120 |
| 7-5 SDRAM DEAC Command for EMIFA | 121 |
| 7-6 SDRAM REFR Command for EMIFA | 121 |
| 7-7 SDRAM MRS Command for EMIFA | 122 |
| 7-8 SDRAM Self-Refresh Timing for EMIFA | 122 |
| | |
| 8-1 HOLD/HOLDA Timing for EMIFA | 123 |
| | |
| 9-1 BUSREQ Timing for EMIFA | 124 |
| | |
| 10-1 Reset Timing† | 126 |
| | |
| 11-1 External/NMI Interrupt Timing | 127 |
| | |
| 12-1 I2C Receive Timings | 128 |
| 12-2 I2C Transmit Timings | 129 |
| | |
| 13-1 HPI16 Read Timing (HAS Not Used, Tied High) | 131 |
| 13-2 HPI16 Read Timing (HAS Used) | 131 |
| 13-3 HPI16 Write Timing (HAS Not Used, Tied High) | 132 |
| 13-4 HPI16 Write Timing (HAS Used) | 132 |
| 13-5 HPI32 Read Timing (HAS Not Used, Tied High) | 133 |
| 13-6 HPI32 Read Timing (HAS Used) | 133 |
| 13-7 HPI32 Write Timing (HAS Not Used, Tied High) | 134 |
| 13-8 HPI32 Write Timing (HAS Used) | 134 |

| <i>Figure</i> | <i>Page</i> |
|---|-------------|
| 14-1 PCLK Timing | 135 |
| 14-2 PCI Reset (PRST) Timing | 135 |
| 14-3 PCI Input Timing (33-/66-MHz) | 136 |
| 14-4 PCI Output Timing (33-/66-MHz) | 136 |
| 14-5 PCI Serial EEPROM Interface Timing | 137 |
| | |
| 15-1 McBSP Timing | 140 |
| 15-2 FSR Timing When GSYNC = 1 | 141 |
| 15-3 McBSP Timing as SPI Master or Slave: CLKSTP = 10b, CLKXP = 0 | 142 |
| 15-4 McBSP Timing as SPI Master or Slave: CLKSTP = 11b, CLKXP = 0 | 143 |
| 15-5 McBSP Timing as SPI Master or Slave: CLKSTP = 10b, CLKXP = 1 | 144 |
| 15-6 McBSP Timing as SPI Master or Slave: CLKSTP = 11b, CLKXP = 1 | 145 |
| | |
| 16-1 MRCLK Timing (EMAC – Receive) | 146 |
| 16-2 MTCLK Timing (EMAC – Transmit) | 146 |
| 16-3 EMAC Receive Interface Timing | 147 |
| 16-4 EMAC Transmit Interface Timing | 147 |
| | |
| 17-1 MDIO Input Timing | 148 |
| 17-2 MDIO Output Timing | 148 |
| | |
| 18-1 Timer Timing | 149 |
| | |
| 19-1 GPIO Port Timing | 150 |
| | |
| 20-1 JTAG Test-Port Timing | 151 |

List of Tables

| <i>Table</i> | | <i>Page</i> |
|--------------|--|-------------|
| 1-1 | Characteristics of the C6412 Processor | 17 |
| 1-2 | TMS320C6412 Memory Map Summary | 22 |
| 1-3 | EMIFA Registers | 25 |
| 1-4 | L2 Cache Registers (C64x) | 25 |
| 1-5 | Quick DMA (QDMA) and Pseudo Registers | 28 |
| 1-6 | EDMA Registers (C64x) | 28 |
| 1-7 | EDMA Parameter RAM (C64x)† | 29 |
| 1-8 | Interrupt Selector Registers (C64x) | 30 |
| 1-9 | Ethernet MAC (EMAC) Control Registers | 30 |
| 1-10 | EMAC Statistics Registers | 33 |
| 1-11 | EMAC Wrapper | 34 |
| 1-12 | EWRAP Registers | 34 |
| 1-13 | Device Configuration Registers | 34 |
| 1-14 | McBSP 0 Registers | 35 |
| 1-15 | McBSP 1 Registers | 35 |
| 1-16 | Timer 0 Registers | 36 |
| 1-17 | Timer 1 Registers | 36 |
| 1-18 | Timer 2 Registers | 36 |
| 1-19 | HPI Registers | 36 |
| 1-20 | GP0 Registers | 37 |
| 1-21 | PCI Peripheral Registers | 37 |
| 1-22 | MDIO Registers | 38 |
| 1-23 | I2C0 Registers | 38 |
| 1-24 | TMS320C6412 EDMA Channel Synchronization Events† | 39 |
| 1-25 | C6412 DSP Interrupts | 41 |
| | | |
| 2-1 | PCI_EN, HD5, and MAC_EN Peripheral Selection (HPI, GP0[15:9], PCI, EMAC, and MDIO) | 47 |
| 2-2 | HPI vs. EMAC Peripheral Pin Selection | 47 |
| 2-3 | C6412 Device Configuration Pins (TOUT1/LENDIAN, AEA[22:19], GP0[3]/PCIEEAI, GP0[8]/PCI66, HD5/AD5, PCI_EN, and TOUT0/MAC_EN) | 48 |
| 2-4 | Peripheral Configuration (PERCFG) Register Selection Bit Descriptions | 49 |
| 2-5 | PCFGLOCK Register Selection Bit Descriptions – Read Accesses | 51 |
| 2-6 | PCFGLOCK Register Selection Bit Descriptions – Write Accesses | 51 |
| 2-7 | Device Status (DEVSTAT) Register Selection Bit Descriptions | 52 |
| 2-8 | JTAG ID Register Selection Bit Descriptions | 53 |
| 2-9 | C6412 Device Multiplexed Pins† | 55 |
| 2-10 | Terminal Functions | 59 |
| 2-11 | TMS320C6412 PLL Multiply Factor Options, Clock Frequency Ranges, and Typical Lock Time†† | 87 |
| 2-12 | Characteristics of the Power-Down Modes | 95 |
| | | |
| 4-1 | Board-Level Timing Example (see Figure 4-6) | 104 |
| 4-2 | Timing Requirements for CLKIN for –500 Devices††§ (see Figure 4-7) | 105 |
| 4-3 | Timing Requirements for CLKIN for –600 Devices††§ (see Figure 4-7) | 105 |
| 4-4 | Timing Requirements for CLKIN for –720 Devices††§ (see Figure 4-7) | 106 |

| <i>Table</i> | <i>Page</i> |
|--------------|---|
| 4-5 | Switching Characteristics Over Recommended Operating Conditions for CLKOUT4 106 |
| 4-6 | Switching Characteristics Over Recommended Operating Conditions for CLKOUT6 107 |
| 4-7 | Timing Requirements for AECLKIN for EMIFA 108 |
| 4-8 | Switching Characteristics Over Recommended Operating Conditions for AECLKOUT1 for the EMIFA Module 108 |
| 4-9 | Switching Characteristics Over Recommended Operating Conditions for AECLKOUT2 for the EMIFA Module 109 |
| 5-1 | Timing Requirements for Asynchronous Memory Cycles for EMIFA Module 110 |
| 5-2 | Switching Characteristics Over Recommended Operating Conditions for Asynchronous Memory Cycles for EMIFA Module 110 |
| 6-1 | Timing Requirements for Programmable Synchronous Interface Cycles for EMIFA Module 113 |
| 6-2 | Switching Characteristics Over Recommended Operating Conditions for Programmable Synchronous Interface Cycles for EMIFA Module 113 |
| 7-1 | Timing Requirements for Synchronous DRAM Cycles for EMIFA Module 117 |
| 7-2 | Switching Characteristics Over Recommended Operating Conditions for Synchronous DRAM Cycles for EMIFA Module 117 |
| 8-1 | Timing Requirements for the HOLD/HOLDA Cycles for EMIFA Module 123 |
| 8-2 | Switching Characteristics Over Recommended Operating Conditions for the HOLD/HOLDA Cycles for EMIFA Module 123 |
| 9-1 | Switching Characteristics Over Recommended Operating Conditions for the BUSREQ Cycles for EMIFA Module 124 |
| 10-1 | Timing Requirements for Reset 125 |
| 10-2 | Switching Characteristics Over Recommended Operating Conditions During Reset 125 |
| 11-1 | Timing Requirements for External Interrupts 127 |
| 12-1 | Timing Requirements for I2C Timings 128 |
| 12-2 | Switching Characteristics for I2C Timings 129 |
| 13-1 | Timing Requirements for Host-Port Interface Cycles 130 |
| 13-2 | Switching Characteristics Over Recommended Operating Conditions During Host-Port Interface Cycles) 130 |
| 14-1 | Timing Requirements for PCLK $\dagger\dagger$ (see Figure 14-1) 135 |
| 14-2 | Timing Requirements for PCI Reset (see Figure 14-2) 135 |
| 14-3 | Timing Requirements for PCI Inputs (see Figure 14-3) 136 |
| 14-4 | Switching Characteristics Over Recommended Operating Conditions for PCI Outputs 136 |

| <i>Table</i> | <i>Page</i> |
|--------------|---|
| 14-5 | Timing Requirements for Serial EEPROM Interface 137 |
| 14-6 | Switching Characteristics Over Recommended Operating Conditions for Serial EEPROM Interface 137 |
| 15-1 | Timing Requirements for McBSP 138 |
| 15-2 | Switching Characteristics Over Recommended Operating Conditions for McBSP 139 |
| 15-3 | Timing Requirements for FSR When GSYNC = 1 141 |
| 15-4 | Timing Requirements for McBSP as SPI Master or Slave: CLKSTP = 10b, CLKXP = 0 142 |
| 15-5 | Switching Characteristics Over Recommended Operating Conditions for McBSP as SPI Master or Slave: CLKSTP = 10b, CLKXP = 0 142 |
| 15-6 | Timing Requirements for McBSP as SPI Master or Slave: CLKSTP = 11b, CLKXP = 0 143 |
| 15-7 | Switching Characteristics Over Recommended Operating Conditions for McBSP as SPI Master or Slave: CLKSTP = 11b, CLKXP = 0 143 |
| 15-8 | Timing Requirements for McBSP as SPI Master or Slave: CLKSTP = 10b, CLKXP = 1 144 |
| 15-9 | Switching Characteristics Over Recommended Operating Conditions for McBSP as SPI Master or Slave: CLKSTP = 10b, CLKXP = 1 144 |
| 15-10 | Timing Requirements for McBSP as SPI Master or Slave: CLKSTP = 11b, CLKXP = 1 145 |
| 15-11 | Switching Characteristics Over Recommended Operating Conditions for McBSP as SPI Master or Slave: CLKSTP = 11b, CLKXP = 1 145 |
| 16-1 | Timing Requirements for MRCLK 146 |
| 16-2 | Timing Requirements for MTCLK 146 |
| 16-3 | Timing Requirements for EMAC MII Receive 10/100 Mbit/s 147 |
| 16-4 | Switching Characteristics Over Recommended Operating Conditions for EMAC MII Transmit 10/100 Mbit/s 147 |
| 17-1 | Timing Requirements for MDIO Input 148 |
| 17-2 | Switching Characteristics Over Recommended Operating Conditions for MDIO Output 148 |
| 18-1 | Timing Requirements for Timer Inputs 149 |
| 18-2 | Switching Characteristics Over Recommended Operating Conditions for Timer Outputs 149 |
| 19-1 | Timing Requirements for GPIO Inputs 150 |
| 19-2 | Switching Characteristics Over Recommended Operating Conditions for GPIO Outputs 150 |
| 20-1 | Timing Requirements for JTAG Test Port 151 |
| 20-2 | Switching Characteristics Over Recommended Operating Conditions for JTAG Test Port 151 |

| <i>Table</i> | | <i>Page</i> |
|--------------|---|-------------|
| 21-1 | Thermal Resistance Characteristics (S-PBGA Package) [GDK] | 152 |
| 21-2 | Thermal Resistance Characteristics (S-PBGA Package) [ZDK] | 152 |
| 21-3 | Thermal Resistance Characteristics (S-PBGA Package) [GNZ] | 153 |
| 21-4 | Thermal Resistance Characteristics (S-PBGA Package) [ZNZ] | 153 |

1 Features

- **High-Performance Fixed-Point Digital Signal Processor (TMS320C6412)**
 - 2-, 1.67-, 1.39-ns Instruction Cycle Time
 - 500-, 600-, 720-MHz Clock Rate
 - Eight 32-Bit Instructions/Cycle
 - 4000, 4800, 5760 MIPS
 - Fully Software-Compatible With C64x™
- **VelociTI.2™ Extensions to VelociTI™ Advanced Very-Long-Instruction-Word (VLIW) TMS320C64x™ DSP Core**
 - Eight Highly Independent Functional Units With VelociTI.2™ Extensions:
 - Six ALUs (32-/40-Bit), Each Supports Single 32-Bit, Dual 16-Bit, or Quad 8-Bit Arithmetic per Clock Cycle
 - Two Multipliers Support Four 16 x 16-Bit Multiplies (32-Bit Results) per Clock Cycle or Eight 8 x 8-Bit Multiplies (16-Bit Results) per Clock Cycle
 - Load-Store Architecture With Non-Aligned Support
 - 64 32-Bit General-Purpose Registers
 - Instruction Packing Reduces Code Size
 - All Instructions Conditional
- **Instruction Set Features**
 - Byte-Addressable (8-/16-/32-/64-Bit Data)
 - 8-Bit Overflow Protection
 - Bit-Field Extract, Set, Clear
 - Normalization, Saturation, Bit-Counting
 - VelociTI.2™ Increased Orthogonality
- **L1/L2 Memory Architecture**
 - 128K-Bit (16K-Byte) L1P Program Cache (Direct Mapped)
 - 128K-Bit (16K-Byte) L1D Data Cache (2-Way Set-Associative)
 - 2M-Bit (256K-Byte) L2 Unified Mapped RAM/Cache (Flexible RAM/Cache Allocation)
- **Endianess: Little Endian, Big Endian**
- **64-Bit External Memory Interface (EMIF)**
 - Glueless Interface to Asynchronous Memories (SRAM and EPROM) and Synchronous Memories (SDRAM, SBSRAM, ZBT SRAM, and FIFO)
 - 1024M-Byte Total Addressable External Memory Space
- **Enhanced Direct-Memory-Access (EDMA) Controller (64 Independent Channels)**
- **10/100 Mb/s Ethernet MAC (EMAC)**
 - IEEE 802.3 Compliant
 - Media Independent Interface (MII)
 - 8 Independent Transmit (TX) Channels and 1 Receive (RX) Channel
- **Management Data Input/Output (MDIO)**
- **Host-Port Interface (HPI) [32-/16-Bit]**
- **32-Bit/66-MHz, 3.3-V Peripheral Component Interconnect (PCI) Master/Slave Interface Conforms to PCI Specification 2.2**
- **Inter-Integrated Circuit (I²C) Bus**
- **Two Multichannel Buffered Serial Ports**
- **Three 32-Bit General-Purpose Timers**
- **Sixteen General-Purpose I/O (GPIO) Pins**
- **Flexible PLL Clock Generator**
- **IEEE-1149.1 (JTAG[†]) Boundary-Scan-Compatible**
- **548-Pin Ball Grid Array (BGA) Package (GDK and ZDK Suffixes), 0.8-mm Ball Pitch**
- **548-Pin Ball Grid Array (BGA) Package (GNZ and ZNZ Suffixes), 1.0-mm Ball Pitch**
- **0.13- μ m/6-Level Cu Metal Process (CMOS)**
- **3.3-V I/Os, 1.2-V Internal (-500)**
- **3.3-V I/Os, 1.4-V Internal (A-500, A-600, -600, -720)**

C64x, VelociTI.2, VelociTI, and TMS320C64x are trademarks of Texas Instruments.

All trademarks are the property of their respective owners.

[†] IEEE Standard 1149.1-1990 Standard-Test-Access Port and Boundary Scan Architecture.

1.1 GDK and ZDK BGA Packages (Bottom View)

GDK and ZDK 548-PIN BALL GRID ARRAY (BGA) PACKAGES
(BOTTOM VIEW)

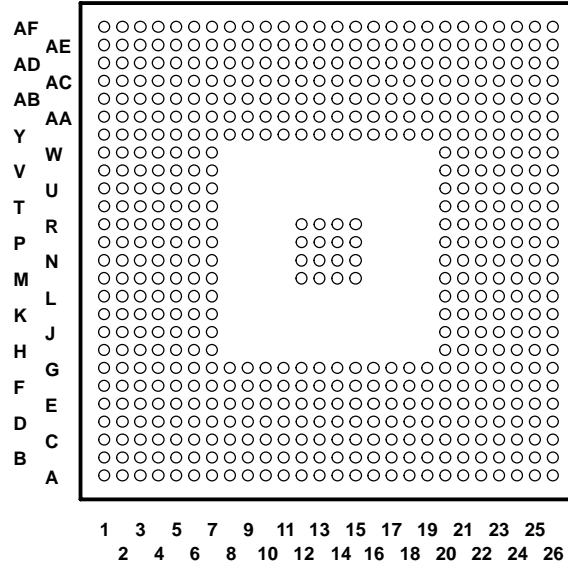

Figure 1–1. GDK and ZDK BGA Packages (Bottom View)

1.2 GNZ and ZNZ BGA Packages (Bottom View)

GNZ and ZNZ 548-PIN BALL GRID ARRAY (BGA) PACKAGES
(BOTTOM VIEW)

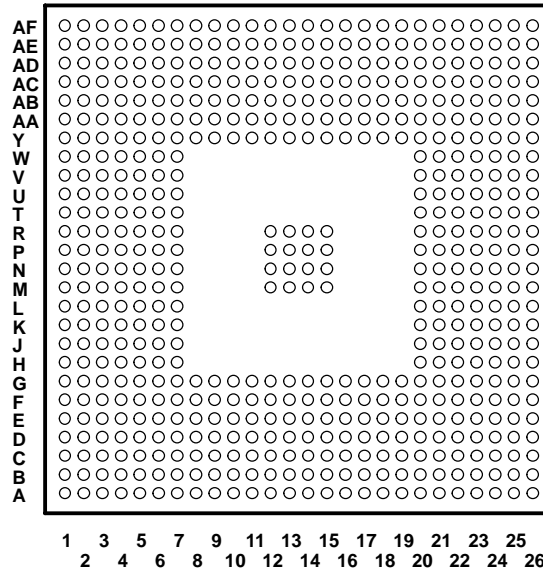

Figure 1–2. GNZ and ZNZ BGA Packages (Bottom View)

1.3 Description

The TMS320C64x™ DSPs (including the TMS320C6412 device) are the highest-performance fixed-point DSP generation in the TMS320C6000™ DSP platform. The TMS320C6412 (C6412) device is based on the second-generation high-performance, advanced VelociTI™ very-long-instruction-word (VLIW) architecture (VelociTI.2™) developed by Texas Instruments (TI), making these DSPs an excellent choice for multichannel and multifunction applications. The C64x™ is a code-compatible member of the C6000™ DSP platform.

With performance of up to 5760 million instructions per second (MIPS) at a clock rate of 720 MHz, the C6412 device offers cost-effective solutions to high-performance DSP programming challenges. The C6412 DSP possesses the operational flexibility of high-speed controllers and the numerical capability of array processors. The C64x™ DSP core processor has 64 general-purpose registers of 32-bit word length and eight highly independent functional units—two multipliers for a 32-bit result and six arithmetic logic units (ALUs)—with VelociTI.2™ extensions. The VelociTI.2™ extensions in the eight functional units include new instructions to accelerate the performance in applications and extend the parallelism of the VelociTI™ architecture. The C6412 can produce four 16-bit multiply-accumulates (MACs) per cycle for a total of 2400 million MACs per second (MMACS), or eight 8-bit MACs per cycle for a total of 4800 MMACS. The C6412 DSP also has application-specific hardware logic, on-chip memory, and additional on-chip peripherals similar to the other C6000™ DSP platform devices.

The C6412 uses a two-level cache-based architecture and has a powerful and diverse set of peripherals. The Level 1 program cache (L1P) is a 128-Kbit direct mapped cache and the Level 1 data cache (L1D) is a 128-Kbit 2-way set-associative cache. The Level 2 memory/cache (L2) consists of an 2-Mbit memory space that is shared between program and data space. L2 memory can be configured as mapped memory, cache, or combinations of the two. The peripheral set includes: a 10/100 Mb/s Ethernet MAC (EMAC); a management data input/output (MDIO) module; an inter-integrated circuit (I2C) Bus module; two multichannel buffered serial ports (McBSPs); three 32-bit general-purpose timers; a user-configurable 16-bit or 32-bit host-port interface (HPI16/HPI32); a peripheral component interconnect (PCI); a 16-pin general-purpose input/output port (GP0) with programmable interrupt/event generation modes; and a 64-bit glueless external memory interface (EMIFA), which is capable of interfacing to synchronous and asynchronous memories and peripherals.

The ethernet media access controller (EMAC) provides an efficient interface between the C6412 DSP core processor and the network. The C6412 EMAC support both 10Base-T and 100Base-TX, or 10 Mbits/second (Mbps) and 100 Mbps in either half- or full-duplex, with hardware flow control and quality of service (QoS) support. The C6412 EMAC makes use of a custom interface to the DSP core that allows efficient data transmission and reception. For more details on the EMAC, see the *TMS320C6000 DSP Ethernet Media Access Controller (EMAC) / Management Data Input/Output (MDIO) Module Reference Guide* (literature number SPRU628).

The management data input/output (MDIO) module continuously polls all 32 MDIO addresses in order to enumerate all PHY devices in the system. Once a PHY candidate has been selected by the DSP, the MDIO module transparently monitors its link state by reading the PHY status register. Link change events are stored in the MDIO module and can optionally interrupt the DSP, allowing the DSP to poll the link status of the device without continuously performing costly MDIO accesses. For more details on the MDIO port, see the *TMS320C6000 DSP Ethernet Media Access Controller (EMAC) / Management Data Input/Output (MDIO) Module Reference Guide* (literature number SPRU628).

The I2C0 port on the TMS320C6412 allows the DSP to easily control peripheral devices and communicate with a host processor. In addition, the standard multichannel buffered serial port (McBSP) may be used to communicate with serial peripheral interface (SPI) mode peripheral devices.

The C6412 has a complete set of development tools which includes: a new C compiler, an assembly optimizer to simplify programming and scheduling, and a Windows™ debugger interface for visibility into source code execution.

TMS320C6000, and C6000 are trademarks of Texas Instruments.

Windows is a registered trademark of the Microsoft Corporation.

1.4 Device Characteristics

Table 1–1 provides an overview of the C6412 DSP. The table shows significant features of the C6412 device, including the capacity of on-chip RAM, the peripherals, the CPU frequency, and the package type with pin count.

Table 1–1. Characteristics of the C6412 Processor

| HARDWARE FEATURES | | C6412 |
|---|--|--|
| Peripherals Not all peripherals pins are available at the same time (For more detail, see the Device Configuration section). | EMIFA (64-bit bus width) (clock source = AECLKIN) | 1 |
| | EDMA (64 independent channels) | 1 |
| | I2C0 (uses Peripheral Clock) | 1 |
| | HPI (32- or 16-bit user selectable) | 1 (HPI16 or HPI32) |
| | PCI (32-bit), 66-MHz/33-MHz [DeviceID Register value 0x9065] | 1 |
| | McBSPs (internal clock source = CPU/4 clock frequency) | 2 |
| | 10/100 Ethernet MAC (EMAC) | 1 |
| | Management Data Input/Output (MDIO) | 1 |
| | 32-Bit Timers (internal clock source = CPU/8 clock frequency) | 3 |
| | General-Purpose Input/Output Port (GP0) | 16 |
| On-Chip Memory | Size (Bytes) | 288K |
| | Organization | 16K-Byte (16KB) L1 Program (L1P) Cache 16KB L1 Data (L1D) Cache 256KB Unified Mapped RAM/Cache (L2) |
| CPU ID + CPU Rev ID | Control Status Register (CSR.[31:16]) | 0x0C01 |
| JTAG BSDL_ID | JTAGID register (address location: 0x01B3F008) | 0x0007902F |
| Frequency | MHz | 500, 600, 720 |
| Cycle Time | ns | 2 ns (C6412-500) and (C6412A-500) [500 MHz CPU, 100 MHz EMIF [†] , 33 MHz PCI port] 1.67 ns (C6412-600) and (C6412A-600) [600 MHz CPU, 133 MHz EMIF [†] , 66 MHz PCI port] 1.39 ns (C6412-720) [720 MHz CPU, 133 MHz EMIF [†] , 66 MHz PCI port] |
| Voltage | Core (V) | 1.2 V (-500) 1.4 V (A-500, A-600, -600, -720) |
| | I/O (V) | 3.3 V |
| PLL Options | CLKIN frequency multiplier | Bypass (x1), x6, x12 |
| BGA Package [‡] | 23 x 23 mm | 548-Pin BGA (GDK and ZDK) |
| | 27 x 27 mm | 548-Pin BGA (GNZ and ZNZ) |
| Process Technology | µm | 0.13 µm |
| Product Status [§] | Product Preview (PP), Advance Information (AI), or Production Data (PD) | PD |

[†] On this C64x™ device, the rated EMIF speed affects only the SDRAM interface on the EMIF. For more detailed information, see the EMIF device speed portion of this data sheet.

[‡] For the exact markings of pin A1, see the *TMS320C6412 Digital Signal Processor Silicon Errata* (Literature Number: SPRZ199).

[§] PRODUCTION DATA information is current as of publication date. Products conform to specifications per the terms of Texas Instruments standard warranty. Production processing does not necessarily include testing of all parameters.

1.4.1 Device Compatibility

The C6412 device is a code-compatible member of the C6000™ DSP platform.

The C64x™ DSP generation of devices has a diverse and powerful set of peripherals.

For more detailed information on the device compatibility and similarities/differences among the DM642, C6412, and other C64x™ devices, see the *TMS320DM642 Technical Overview* (literature number SPRU615).

1.4.2 Functional Block Diagram

Figure 1–3 shows the functional block diagram of the C6412 device.

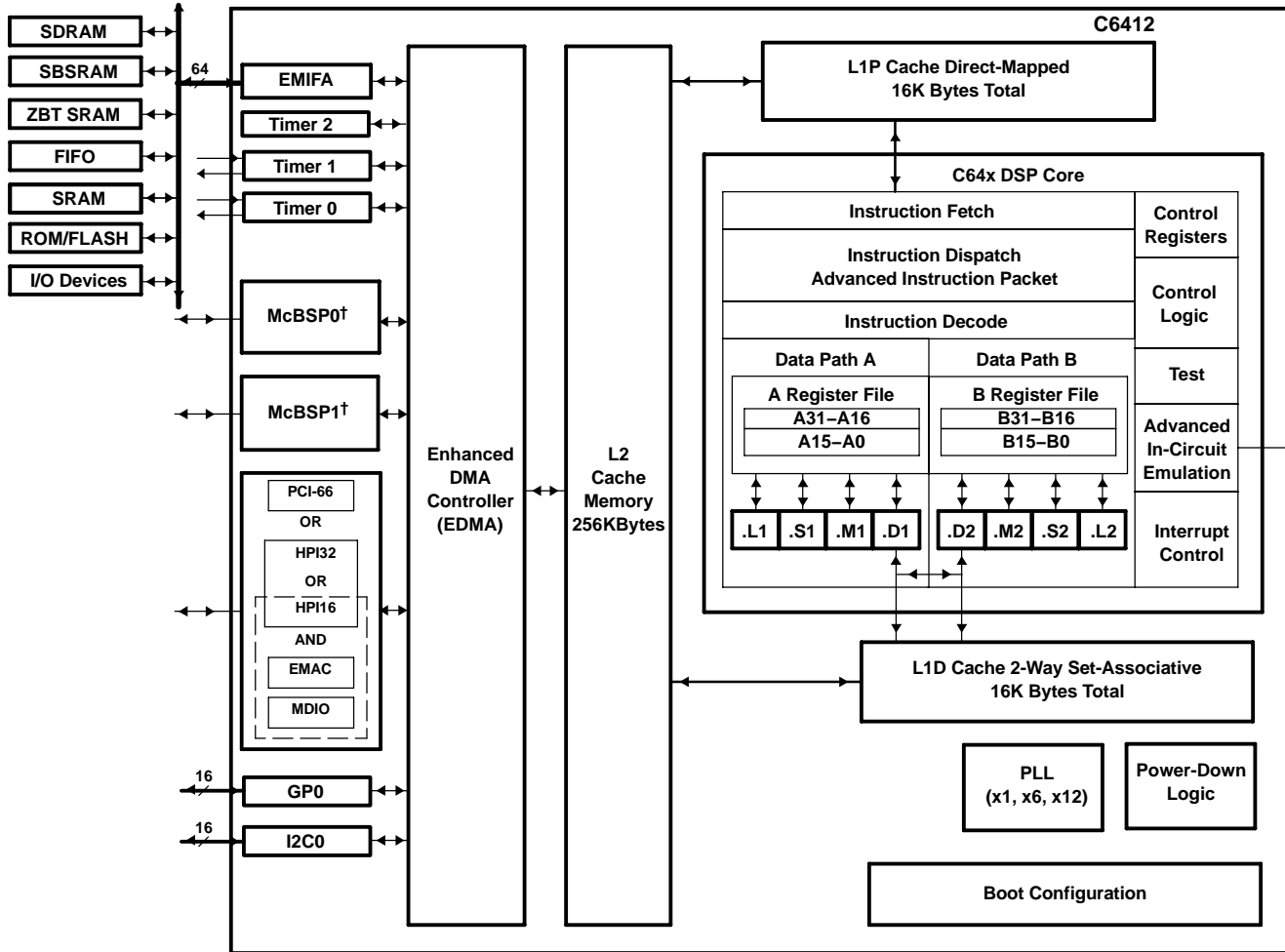

† McBSPs: Framing Chips – H.100, MVIP, SCSA, T1, E1; AC97 Devices; SPI Devices; Codecs

Figure 1–3. Functional Block Diagram

1.5 CPU (DSP Core) Description

The CPU fetches VelociTI™ advanced very-long instruction words (VLIWs) (256 bits wide) to supply up to eight 32-bit instructions to the eight functional units during every clock cycle. The VelociTI™ VLIW architecture features controls by which all eight units do not have to be supplied with instructions if they are not ready to execute. The first bit of every 32-bit instruction determines if the next instruction belongs to the same execute packet as the previous instruction, or whether it should be executed in the following clock as a part of the next execute packet. Fetch packets are always 256 bits wide; however, the execute packets can vary in size. The variable-length execute packets are a key memory-saving feature, distinguishing the C64x CPUs from other VLIW architectures. The C64x™ VelociTI.2™ extensions add enhancements to the TMS320C62x™ DSP VelociTI™ architecture. These enhancements include:

- Register file enhancements
- Data path extensions
- Quad 8-bit and dual 16-bit extensions with data flow enhancements
- Additional functional unit hardware
- Increased orthogonality of the instruction set
- Additional instructions that reduce code size and increase register flexibility

The CPU features two sets of functional units. Each set contains four units and a register file. One set contains functional units .L1, .S1, .M1, and .D1; the other set contains units .D2, .M2, .S2, and .L2. The two register files each contain 32 32-bit registers for a total of 64 general-purpose registers. In addition to supporting the packed 16-bit and 32-/40-bit fixed-point data types found in the C62x™ VelociTI™ VLIW architecture, the C64x™ register files also support packed 8-bit data and 64-bit fixed-point data types. The two sets of functional units, along with two register files, compose sides A and B of the CPU [see the functional block and CPU (DSP core) diagram, and Figure 1–4]. The four functional units on each side of the CPU can freely share the 32 registers belonging to that side. Additionally, each side features a “data cross path”—a single data bus connected to all the registers on the other side, by which the two sets of functional units can access data from the register files on the opposite side. The C64x CPU pipelines data-cross-path accesses over multiple clock cycles. This allows the same register to be used as a data-cross-path operand by multiple functional units in the same execute packet. All functional units in the C64x CPU can access operands via the data cross path. Register access by functional units on the same side of the CPU as the register file can service all the units in a single clock cycle. On the C64x CPU, a delay clock is introduced whenever an instruction attempts to read a register via a data cross path if that register was updated in the previous clock cycle.

In addition to the C62x™ DSP fixed-point instructions, the C64x™ DSP includes a comprehensive collection of quad 8-bit and dual 16-bit instruction set extensions. These VelociTI.2™ extensions allow the C64x CPU to operate directly on packed data to streamline data flow and increase instruction set efficiency. This is a key factor for video and imaging applications.

Another key feature of the C64x CPU is the load/store architecture, where all instructions operate on registers (as opposed to data in memory). Two sets of data-addressing units (.D1 and .D2) are responsible for all data transfers between the register files and the memory. The data address driven by the .D units allows data addresses generated from one register file to be used to load or store data to or from the other register file. The C64x .D units can load and store bytes (8 bits), half-words (16 bits), and words (32 bits) with a single instruction. And with the new data path extensions, the C64x .D unit can load and store doublewords (64 bits) with a single instruction. Furthermore, the non-aligned load and store instructions allow the .D units to access words and doublewords on any byte boundary. The C64x CPU supports a variety of indirect addressing modes using either linear- or circular-addressing with 5- or 15-bit offsets. All instructions are conditional, and most can access any one of the 64 registers. Some registers, however, are singled out to support specific addressing modes or to hold the condition for conditional instructions (if the condition is not automatically “true”).

TMS320C62x is a trademark of Texas Instruments.

The two .M functional units perform all multiplication operations. Each of the C64x .M units can perform two 16×16 -bit multiplies or four 8×8 -bit multiplies per clock cycle. The .M unit can also perform 16×32 -bit multiply operations, dual 16×16 -bit multiplies with add/subtract operations, and quad 8×8 -bit multiplies with add operations. In addition to standard multiplies, the C64x .M units include bit-count, rotate, Galois field multiplies, and bidirectional variable shift hardware.

The two .S and .L functional units perform a general set of arithmetic, logical, and branch functions with results available every clock cycle. The arithmetic and logical functions on the C64x CPU include single 32-bit, dual 16-bit, and quad 8-bit operations.

The processing flow begins when a 256-bit-wide instruction fetch packet is fetched from a program memory. The 32-bit instructions destined for the individual functional units are "linked" together by "1" bits in the least significant bit (LSB) position of the instructions. The instructions that are "chained" together for simultaneous execution (up to eight in total) compose an execute packet. A "0" in the LSB of an instruction breaks the chain, effectively placing the instructions that follow it in the next execute packet. A C64x™ DSP device enhancement now allows execute packets to cross fetch-packet boundaries. In the TMS320C62x™/TMS320C67x™ DSP devices, if an execute packet crosses the fetch-packet boundary (256 bits wide), the assembler places it in the next fetch packet, while the remainder of the current fetch packet is padded with NOP instructions. In the C64x™ DSP device, the execute boundary restrictions have been removed, thereby, eliminating all of the NOPs added to pad the fetch packet, and thus, decreasing the overall code size. The number of execute packets within a fetch packet can vary from one to eight. Execute packets are dispatched to their respective functional units at the rate of one per clock cycle and the next 256-bit fetch packet is not fetched until all the execute packets from the current fetch packet have been dispatched. After decoding, the instructions simultaneously drive all active functional units for a maximum execution rate of eight instructions every clock cycle. While most results are stored in 32-bit registers, they can be subsequently moved to memory as bytes, half-words, or doublewords. All load and store instructions are byte-, half-word-, word-, or doubleword-addressable.

For more details on the C64x CPU functional units enhancements, see the following documents:

- *TMS320C6000 CPU and Instruction Set Reference Guide* (literature number SPRU189)
- *TMS320C64x Technical Overview* (literature number SPRU395)

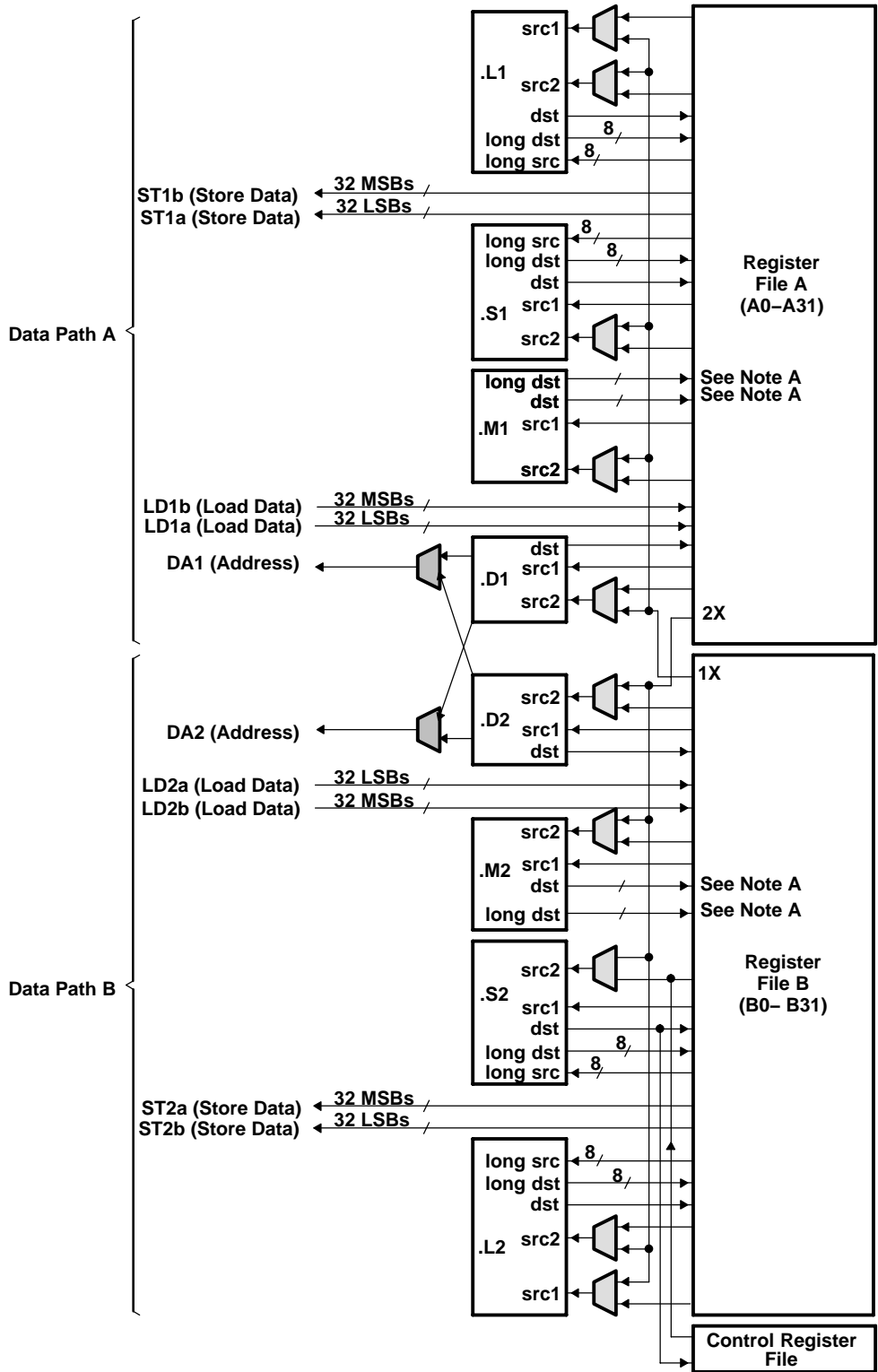

NOTE A: For the .M functional units, the long dst is 32 MSBs and the dst is 32 LSBs.

Figure 1-4. TMS320C64x™ CPU (DSP Core) Data Paths

1.6 Memory Map Summary

Table 1–2 shows the memory map address ranges of the C6412 device. Internal memory is always located at address 0 and can be used as both program and data memory. The external memory address ranges in the C6412 device begin at the hex address location 0x8000 0000 for EMIFA.

Table 1–2. TMS320C6412 Memory Map Summary

| MEMORY BLOCK DESCRIPTION | BLOCK SIZE (BYTES) | HEX ADDRESS RANGE |
|---|--------------------|-----------------------|
| Internal RAM (L2) | 256K | 0000 0000 – 0003 FFFF |
| Reserved | 768K | 0004 0000 – 000F FFFF |
| Reserved | 23M | 0010 0000 – 017F FFFF |
| External Memory Interface A (EMIFA) Registers | 256K | 0180 0000 – 0183 FFFF |
| L2 Registers | 256K | 0184 0000 – 0187 FFFF |
| HPI Registers | 256K | 0188 0000 – 018B FFFF |
| McBSP 0 Registers | 256K | 018C 0000 – 018F FFFF |
| McBSP 1 Registers | 256K | 0190 0000 – 0193 FFFF |
| Timer 0 Registers | 256K | 0194 0000 – 0197 FFFF |
| Timer 1 Registers | 256K | 0198 0000 – 019B FFFF |
| Interrupt Selector Registers | 256K | 019C 0000 – 019F FFFF |
| EDMA RAM and EDMA Registers | 256K | 01A0 0000 – 01A3 FFFF |
| Reserved | 512K | 01A4 0000 – 01AB FFFF |
| Timer 2 Registers | 256K | 01AC 0000 – 01AF FFFF |
| GP0 Registers | 256K – 4K | 01B0 0000 – 01B3 EFFF |
| Device Configuration Registers | 4K | 01B3 F000 – 01B3 FFFF |
| I2C0 Data and Control Registers | 16K | 01B4 0000 – 01B4 3FFF |
| Reserved | 496K | 01B4 4000 – 01BB BFFF |
| Emulation | 256K | 01BC 0000 – 01BF FFFF |
| PCI Registers | 256K | 01C0 0000 – 01C3 FFFF |
| Reserved | 256K | 01C4 0000 – 01C7 FFFF |
| EMAC Control | 4K | 01C8 0000 – 01C8 0FFF |
| EMAC Wrapper | 8K | 01C8 1000 – 01C8 2FFF |
| EWRAP Registers | 2K | 01C8 3000 – 01C8 37FF |
| MDIO Control Registers | 2K | 01C8 3800 – 01C8 3FFF |
| Reserved | 3.5M | 01C8 4000 – 01FF FFFF |
| QDMA Registers | 52 | 0200 0000 – 0200 0033 |
| Reserved | 736M – 52 | 0200 0034 – 2FFF FFFF |
| McBSP 0 Data | 64M | 3000 0000 – 33FF FFFF |
| McBSP 1 Data | 64M | 3400 0000 – 37FF FFFF |
| Reserved | 64M | 3800 0000 – 3BFF FFFF |
| Reserved | 1M | 3C00 0000 – 3C0F FFFF |
| Reserved | 64M – 1M | 3C10 0000 – 3FFF FFFF |
| Reserved | 832M | 4000 0000 – 73FF FFFF |
| Reserved | 192M | 7400 0000 – 75FF FFFF |
| Reserved | 192M | 7600 0000 – 77FF FFFF |

Table 1–2. TMS320C6412 Memory Map Summary (Continued)

| MEMORY BLOCK DESCRIPTION | BLOCK SIZE (BYTES) | HEX ADDRESS RANGE |
|--------------------------|--------------------|-----------------------|
| Reserved | 192M | 7800 0000 - 79FF FFFF |
| Reserved | 192M | 7A00 0000 - 7BFF FFFF |
| Reserved | 192M | 7C00 0000 - 7DFF FFFF |
| Reserved | 192M | 7E00 0000 - 7FFF FFFF |
| EMIFA CE0 | 256M | 8000 0000 - 8FFF FFFF |
| EMIFA CE1 | 256M | 9000 0000 - 9FFF FFFF |
| EMIFA CE2 | 256M | A000 0000 - AFFF FFFF |
| EMIFA CE3 | 256M | B000 0000 - BFFF FFFF |
| Reserved | 1G | C000 0000 - FFFF FFFF |

1.6.1 L2 Architecture Expanded

Figure 1–5 shows the detail of the L2 architecture on the TMS320C6412 device. For more information on the L2MODE bits, see the cache configuration (CCFG) register bit field descriptions in the *TMS320C64x Two-Level Internal Memory Reference Guide* (literature number SPRU610).

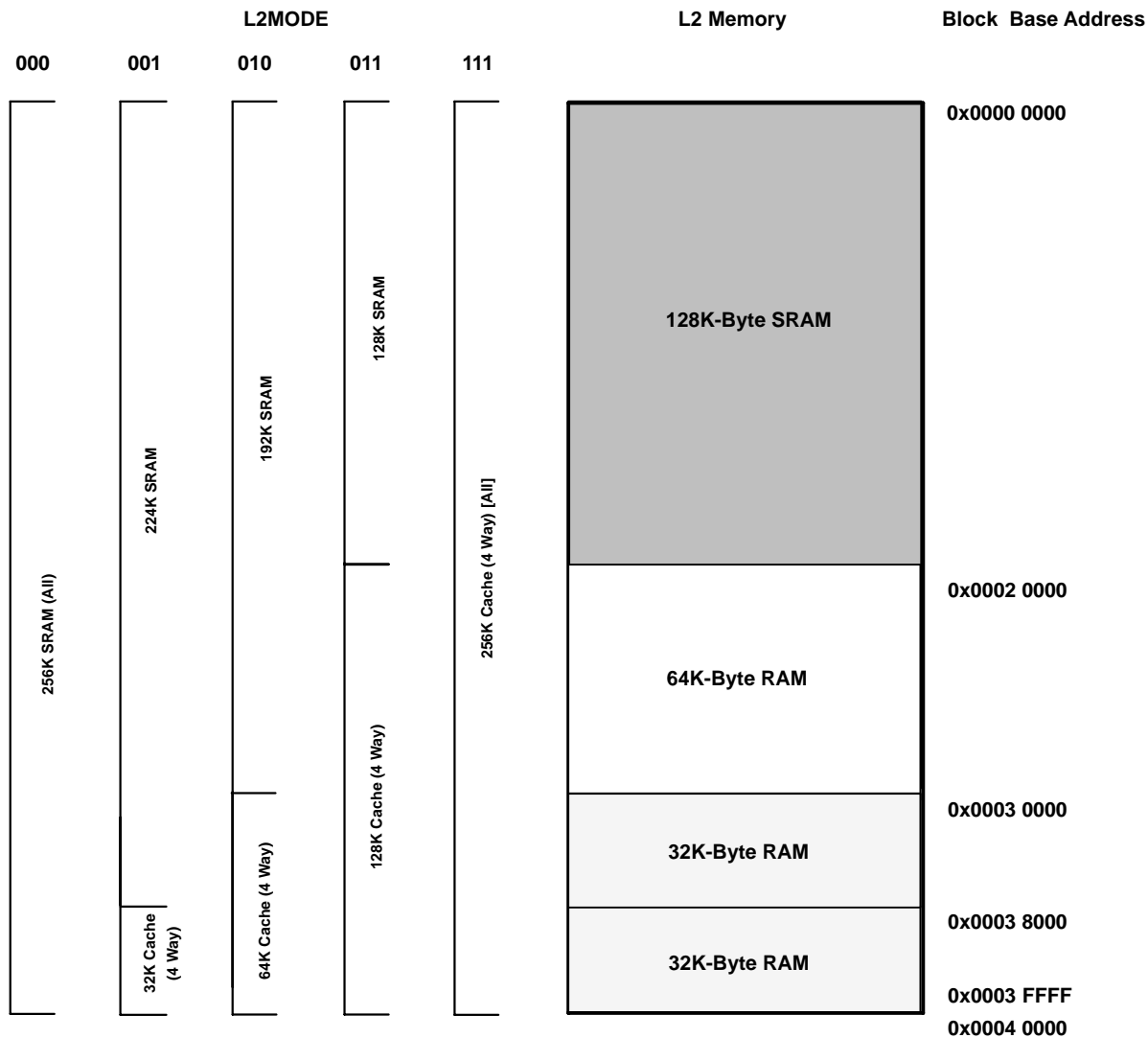

Figure 1–5. TMS320C6412 L2 Architecture Memory Configuration

1.7 Peripheral Register Descriptions

Table 1–3 through Table 1–23 identify the peripheral registers for the C6412 device by their register names, acronyms, and hex address or hex address range. For more detailed information on the register contents, bit names and their descriptions, see the specific peripheral reference guide listed in the *TMS320C6000 DSP Peripherals Overview Reference Guide* (literature number SPRU190).

Table 1–3. EMIFA Registers

| HEX ADDRESS RANGE | ACRONYM | REGISTER NAME | COMMENTS |
|-----------------------|---------|--|----------|
| 0180 0000 | GBLCTL | EMIFA global control | |
| 0180 0004 | CECTL1 | EMIFA CE1 space control | |
| 0180 0008 | CECTL0 | EMIFA CE0 space control | |
| 0180 000C | – | Reserved | |
| 0180 0010 | CECTL2 | EMIFA CE2 space control | |
| 0180 0014 | CECTL3 | EMIFA CE3 space control | |
| 0180 0018 | SDCTL | EMIFA SDRAM control | |
| 0180 001C | SDTIM | EMIFA SDRAM refresh control | |
| 0180 0020 | SDEXT | EMIFA SDRAM extension | |
| 0180 0024 – 0180 003C | – | Reserved | |
| 0180 0040 | PDTCTL | Peripheral device transfer (PDT) control | |
| 0180 0044 | CESEC1 | EMIFA CE1 space secondary control | |
| 0180 0048 | CESEC0 | EMIFA CE0 space secondary control | |
| 0180 004C | – | Reserved | |
| 0180 0050 | CESEC2 | EMIFA CE2 space secondary control | |
| 0180 0054 | CESEC3 | EMIFA CE3 space secondary control | |
| 0180 0058 – 0183 FFFF | – | Reserved | |

Table 1–4. L2 Cache Registers (C64x)

| HEX ADDRESS RANGE | ACRONYM | REGISTER NAME | COMMENTS |
|-----------------------|------------|--|----------|
| 0184 0000 | CCFG | Cache configuration register | |
| 0184 0004 – 0184 0FFC | – | Reserved | |
| 0184 1000 | EDMAWEIGHT | L2 EDMA access control register | |
| 0184 1004 – 0184 1FFC | – | Reserved | |
| 0184 2000 | L2ALLOC0 | L2 allocation register 0 | |
| 0184 2004 | L2ALLOC1 | L2 allocation register 1 | |
| 0184 2008 | L2ALLOC2 | L2 allocation register 2 | |
| 0184 200C | L2ALLOC3 | L2 allocation register 3 | |
| 0184 2010 – 0184 3FFC | – | Reserved | |
| 0184 4000 | L2WBAR | L2 writeback base address register | |
| 0184 4004 | L2WWC | L2 writeback word count register | |
| 0184 4010 | L2WIBAR | L2 writeback invalidate base address register | |
| 0184 4014 | L2WIWC | L2 writeback invalidate word count register | |
| 0184 4018 | L2IBAR | L2 invalidate base address register | |
| 0184 401C | L2IWC | L2 invalidate word count register | |
| 0184 4020 | L1PIBAR | L1P invalidate base address register | |
| 0184 4024 | L1PIWC | L1P invalidate word count register | |
| 0184 4030 | L1DWIBAR | L1D writeback invalidate base address register | |

Table 1–4. L2 Cache Registers (C64x) (Continued)

| HEX ADDRESS RANGE | ACRONYM | REGISTER NAME | COMMENTS |
|-----------------------|----------------|--|----------|
| 0184 4034 | L1DWIWC | L1D writeback invalidate word count register | |
| 0184 4038 – 0184 4044 | – | Reserved | |
| 0184 4048 | L1DIBAR | L1D invalidate base address register | |
| 0184 404C | L1DIWC | L1D invalidate word count register | |
| 0184 4050 – 0184 4FFC | – | Reserved | |
| 0184 5000 | L2WB | L2 writeback all register | |
| 0184 5004 | L2WBINV | L2 writeback invalidate all register | |
| 0184 5008 – 0184 7FFC | – | Reserved | |
| 0184 8000 – 0184 81FC | MAR0 to MAR127 | Reserved | |
| 0184 8200 | MAR128 | Controls EMIFA CE0 range 8000 0000 – 80FF FFFF | |
| 0184 8204 | MAR129 | Controls EMIFA CE0 range 8100 0000 – 81FF FFFF | |
| 0184 8208 | MAR130 | Controls EMIFA CE0 range 8200 0000 – 82FF FFFF | |
| 0184 820C | MAR131 | Controls EMIFA CE0 range 8300 0000 – 83FF FFFF | |
| 0184 8210 | MAR132 | Controls EMIFA CE0 range 8400 0000 – 84FF FFFF | |
| 0184 8214 | MAR133 | Controls EMIFA CE0 range 8500 0000 – 85FF FFFF | |
| 0184 8218 | MAR134 | Controls EMIFA CE0 range 8600 0000 – 86FF FFFF | |
| 0184 821C | MAR135 | Controls EMIFA CE0 range 8700 0000 – 87FF FFFF | |
| 0184 8220 | MAR136 | Controls EMIFA CE0 range 8800 0000 – 88FF FFFF | |
| 0184 8224 | MAR137 | Controls EMIFA CE0 range 8900 0000 – 89FF FFFF | |
| 0184 8228 | MAR138 | Controls EMIFA CE0 range 8A00 0000 – 8AFF FFFF | |
| 0184 822C | MAR139 | Controls EMIFA CE0 range 8B00 0000 – 8BFF FFFF | |
| 0184 8230 | MAR140 | Controls EMIFA CE0 range 8C00 0000 – 8CFF FFFF | |
| 0184 8234 | MAR141 | Controls EMIFA CE0 range 8D00 0000 – 8DFF FFFF | |
| 0184 8238 | MAR142 | Controls EMIFA CE0 range 8E00 0000 – 8EFF FFFF | |
| 0184 823C | MAR143 | Controls EMIFA CE0 range 8F00 0000 – 8FFF FFFF | |
| 0184 8240 | MAR144 | Controls EMIFA CE1 range 9000 0000 – 90FF FFFF | |
| 0184 8244 | MAR145 | Controls EMIFA CE1 range 9100 0000 – 91FF FFFF | |
| 0184 8248 | MAR146 | Controls EMIFA CE1 range 9200 0000 – 92FF FFFF | |
| 0184 824C | MAR147 | Controls EMIFA CE1 range 9300 0000 – 93FF FFFF | |
| 0184 8250 | MAR148 | Controls EMIFA CE1 range 9400 0000 – 94FF FFFF | |
| 0184 8254 | MAR149 | Controls EMIFA CE1 range 9500 0000 – 95FF FFFF | |
| 0184 8258 | MAR150 | Controls EMIFA CE1 range 9600 0000 – 96FF FFFF | |
| 0184 825C | MAR151 | Controls EMIFA CE1 range 9700 0000 – 97FF FFFF | |
| 0184 8260 | MAR152 | Controls EMIFA CE1 range 9800 0000 – 98FF FFFF | |
| 0184 8264 | MAR153 | Controls EMIFA CE1 range 9900 0000 – 99FF FFFF | |
| 0184 8268 | MAR154 | Controls EMIFA CE1 range 9A00 0000 – 9AFF FFFF | |
| 0184 826C | MAR155 | Controls EMIFA CE1 range 9B00 0000 – 9BFF FFFF | |
| 0184 8270 | MAR156 | Controls EMIFA CE1 range 9C00 0000 – 9CFF FFFF | |
| 0184 8274 | MAR157 | Controls EMIFA CE1 range 9D00 0000 – 9DFF FFFF | |
| 0184 8278 | MAR158 | Controls EMIFA CE1 range 9E00 0000 – 9EFF FFFF | |
| 0184 827C | MAR159 | Controls EMIFA CE1 range 9F00 0000 – 9FFF FFFF | |

Table 1–4. L2 Cache Registers (C64x) (Continued)

| HEX ADDRESS RANGE | ACRONYM | REGISTER NAME | COMMENTS |
|----------------------|---------------------|--|----------|
| 0184 8280 | MAR160 | Controls EMIFA CE2 range A000 0000 – A0FF FFFF | |
| 0184 8284 | MAR161 | Controls EMIFA CE2 range A100 0000 – A1FF FFFF | |
| 0184 8288 | MAR162 | Controls EMIFA CE2 range A200 0000 – A2FF FFFF | |
| 0184 828C | MAR163 | Controls EMIFA CE2 range A300 0000 – A3FF FFFF | |
| 0184 8290 | MAR164 | Controls EMIFA CE2 range A400 0000 – A4FF FFFF | |
| 0184 8294 | MAR165 | Controls EMIFA CE2 range A500 0000 – A5FF FFFF | |
| 0184 8298 | MAR166 | Controls EMIFA CE2 range A600 0000 – A6FF FFFF | |
| 0184 829C | MAR167 | Controls EMIFA CE2 range A700 0000 – A7FF FFFF | |
| 0184 82A0 | MAR168 | Controls EMIFA CE2 range A800 0000 – A8FF FFFF | |
| 0184 82A4 | MAR169 | Controls EMIFA CE2 range A900 0000 – A9FF FFFF | |
| 0184 82A8 | MAR170 | Controls EMIFA CE2 range AA00 0000 – AAFF FFFF | |
| 0184 82AC | MAR171 | Controls EMIFA CE2 range AB00 0000 – ABFF FFFF | |
| 0184 82B0 | MAR172 | Controls EMIFA CE2 range AC00 0000 – ACFF FFFF | |
| 0184 82B4 | MAR173 | Controls EMIFA CE2 range AD00 0000 – ADFF FFFF | |
| 0184 82B8 | MAR174 | Controls EMIFA CE2 range AE00 0000 – AEF FFFF | |
| 0184 82BC | MAR175 | Controls EMIFA CE2 range AF00 0000 – AFFF FFFF | |
| 0184 82C0 | MAR176 | Controls EMIFA CE3 range B000 0000 – B0FF FFFF | |
| 0184 82C4 | MAR177 | Controls EMIFA CE3 range B100 0000 – B1FF FFFF | |
| 0184 82C8 | MAR178 | Controls EMIFA CE3 range B200 0000 – B2FF FFFF | |
| 0184 82CC | MAR179 | Controls EMIFA CE3 range B300 0000 – B3FF FFFF | |
| 0184 82D0 | MAR180 | Controls EMIFA CE3 range B400 0000 – B4FF FFFF | |
| 0184 82D4 | MAR181 | Controls EMIFA CE3 range B500 0000 – B5FF FFFF | |
| 0184 82D8 | MAR182 | Controls EMIFA CE3 range B600 0000 – B6FF FFFF | |
| 0184 82DC | MAR183 | Controls EMIFA CE3 range B700 0000 – B7FF FFFF | |
| 0184 82E0 | MAR184 | Controls EMIFA CE3 range B800 0000 – B8FF FFFF | |
| 0184 82E4 | MAR185 | Controls EMIFA CE3 range B900 0000 – B9FF FFFF | |
| 0184 82E8 | MAR186 | Controls EMIFA CE3 range BA00 0000 – BAF FFFF | |
| 0184 82EC | MAR187 | Controls EMIFA CE3 range BB00 0000 – BBFF FFFF | |
| 0184 82F0 | MAR188 | Controls EMIFA CE3 range BC00 0000 – BCFF FFFF | |
| 0184 82F4 | MAR189 | Controls EMIFA CE3 range BD00 0000 – BDFF FFFF | |
| 0184 82F8 | MAR190 | Controls EMIFA CE3 range BE00 0000 – BEFF FFFF | |
| 0184 82FC | MAR191 | Controls EMIFA CE3 range BF00 0000 – BFFF FFFF | |
| 0184 8300 –0184 83FC | MAR192 to MAR255 | Reserved | |
| 0184 8400 –0187 FFFF | – | Reserved | |

Table 1–5. Quick DMA (QDMA) and Pseudo Registers

| HEX ADDRESS RANGE | ACRONYM | REGISTER NAME |
|-----------------------|---------|-------------------------------------|
| 0200 0000 | QOPT | QDMA options parameter register |
| 0200 0004 | QSRC | QDMA source address register |
| 0200 0008 | QCNT | QDMA frame count register |
| 0200 000C | QDST | QDMA destination address register |
| 0200 0010 | QIDX | QDMA index register |
| 0200 0014 – 0200 001C | | Reserved |
| 0200 0020 | QSOPT | QDMA pseudo options register |
| 0200 0024 | QSSRC | QDMA psuedo source address register |
| 0200 0028 | QSCNT | QDMA psuedo frame count register |
| 0200 002C | QSDST | QDMA destination address register |
| 0200 0030 | QSIDX | QDMA psuedo index register |

Table 1–6. EDMA Registers (C64x)

| HEX ADDRESS RANGE | ACRONYM | REGISTER NAME |
|-----------------------|---------|---|
| 01A0 0800 – 01A0 FF98 | – | Reserved |
| 01A0 FF9C | EPRH | Event polarity high register |
| 01A0 FFA4 | CIPRH | Channel interrupt pending high register |
| 01A0 FFA8 | CIERH | Channel interrupt enable high register |
| 01A0 FFAC | CCERH | Channel chain enable high register |
| 01A0 FFB0 | ERH | Event high register |
| 01A0 FFB4 | EERH | Event enable high register |
| 01A0 FFB8 | ECRH | Event clear high register |
| 01A0 FFBC | ESRH | Event set high register |
| 01A0 FFC0 | PQAR0 | Priority queue allocation register 0 |
| 01A0 FFC4 | PQAR1 | Priority queue allocation register 1 |
| 01A0 FFC8 | PQAR2 | Priority queue allocation register 2 |
| 01A0 FFCC | PQAR3 | Priority queue allocation register 3 |
| 01A0 FFDC | EPRL | Event polarity low register |
| 01A0 FFE0 | PQSR | Priority queue status register |
| 01A0 FFE4 | CIPRL | Channel interrupt pending low register |
| 01A0 FFE8 | CIERL | Channel interrupt enable low register |
| 01A0 FFEC | CCERL | Channel chain enable low register |
| 01A0 FFF0 | ERL | Event low register |
| 01A0 FFF4 | EERL | Event enable low register |
| 01A0 FFF8 | ECRL | Event clear low register |
| 01A0 FFFC | ESRL | Event set low register |
| 01A1 0000 – 01A3 FFFF | – | Reserved |

Table 1–7. EDMA Parameter RAM (C64x)†

| HEX ADDRESS RANGE | ACRONYM | REGISTER NAME | COMMENTS |
|------------------------|---------|--|--|
| 01A0 0000 – 01A0 0017 | – | Parameters for Event 0 (6 words) | Parameters for Event 0 (6 words) or Reload/Link Parameters for other Event |
| 01A0 0018 – 01A0 002F | – | Parameters for Event 1 (6 words) | |
| 01A0 0030 – 01A0 0047 | – | Parameters for Event 2 (6 words) | |
| 01A0 0048 – 01A0 005F | – | Parameters for Event 3 (6 words) | |
| 01A0 0060 – 01A0 0077 | – | Parameters for Event 4 (6 words) | |
| 01A0 0078 – 01A0 008F | – | Parameters for Event 5 (6 words) | |
| 01A0 0090 – 01A0 00A7 | – | Parameters for Event 6 (6 words) | |
| 01A0 00A8 – 01A0 00BF | – | Parameters for Event 7 (6 words) | |
| 01A0 00C0 – 01A0 00D7 | – | Parameters for Event 8 (6 words) | |
| 01A0 00D8 – 01A0 00EF | – | Parameters for Event 9 (6 words) | |
| 01A0 00F0 – 01A0 00107 | – | Parameters for Event 10 (6 words) | |
| 01A0 0108 – 01A0 011F | – | Parameters for Event 11 (6 words) | |
| 01A0 0120 – 01A0 0137 | – | Parameters for Event 12 (6 words) | |
| 01A0 0138 – 01A0 014F | – | Parameters for Event 13 (6 words) | |
| 01A0 0150 – 01A0 0167 | – | Parameters for Event 14 (6 words) | |
| 01A0 0168 – 01A0 017F | – | Parameters for Event 15 (6 words) | |
| 01A0 0180 – 01A0 0197 | – | Parameters for Event 16 (6 words) | |
| 01A0 0198 – 01A0 01AF | – | Parameters for Event 17 (6 words) | |
| ... | | ... | |
| 01A0 05D0 – 01A0 05E7 | – | Parameters for Event 62 (6 words) | |
| 01A0 05E8 – 01A0 05FF | – | Parameters for Event 63 (6 words) | |
| 01A0 0600 – 01A0 0617 | – | Reload/link parameters for Event 0 (6 words) | Reload/Link Parameters for other Event 0–15 |
| 01A0 0618 – 01A0 062F | – | Reload/link parameters for Event 1 (6 words) | |
| ... | | ... | |
| 01A0 07E0 – 01A0 07F7 | – | Reload/link parameters for Event 20 (6 words) | |
| 01A0 07F8 – 01A0 080F | – | Reload/link parameters for Event 21 (6 words) | |
| 01A0 0810 – 01A0 0827 | – | Reload/link parameters for Event 22 (6 words) | |
| ... | | ... | |
| 01A0 13C8 – 01A0 13DF | – | Reload/link parameters for Event 147 (6 words) | |
| 01A0 13E0 – 01A0 13F7 | – | Reload/link parameters for Event 148 (6 words) | |
| 01A0 13F8 – 01A0 13FF | – | Scratch pad area (2 words) | |
| 01A0 1400 – 01A3 FFFF | – | Reserved | |

† The C6412 device has 213 EDMA parameters total: 64-Event/Reload channels and 149-Reload only parameter sets [six (6) words each] that can be used to reload/link EDMA transfers.

Table 1–8. Interrupt Selector Registers (C64x)

| HEX ADDRESS RANGE | ACRONYM | REGISTER NAME | COMMENTS |
|-----------------------|---------|-----------------------------|---|
| 019C 0000 | MUXH | Interrupt multiplexer high | Selects which interrupts drive CPU interrupts 10–15 (INT10–INT15) |
| 019C 0004 | MUXL | Interrupt multiplexer low | Selects which interrupts drive CPU interrupts 4–9 (INT04–INT09) |
| 019C 0008 | EXTPOL | External interrupt polarity | Sets the polarity of the external interrupts (EXT_INT4–EXT_INT7) |
| 019C 000C – 019F FFFF | – | Reserved | |

Table 1–9. Ethernet MAC (EMAC) Control Registers

| HEX ADDRESS RANGE | ACRONYM | REGISTER NAME |
|-----------------------|-------------------|---|
| 01C8 0000 | TXIDVER | Transmit Identification and Version Register |
| 01C8 0004 | TXCONTROL | Transmit Control Register |
| 01C8 0008 | TXTEARDOWN | Transmit Teardown Register |
| 01C8 000C | – | Reserved |
| 01C8 0010 | RXIDVER | Receive Identification and Version Register |
| 01C8 0014 | RXCONTROL | Receive Control Register |
| 01C8 0018 | RXTEARDOWN | Receive Teardown Register (RXTDNCH field only supports writes of 0.) |
| 01C8 001C – 01C8 00FF | – | Reserved |
| 01C8 0100 | RXMBPENABLE | Receive Multicast/Broadcast/Promiscuous Channel Enable Register (The RXQSEN field is reserved and only supports writes of 0. The PROMCH, BROADCAST, and MUCTCH bit fields only support writes of 0.) |
| 01C8 0104 | RXUNICASTSET | Receive Unicast Set Register (Bits 7–1 are reserved and only support writes of 0.) |
| 01C8 0108 | RXUNICASTCLEAR | Receive Unicast Clear Register (Bits 7–1 are reserved and only support writes of 0.) |
| 01C8 010C | RXMAXLEN | Receive Maximum Length Register |
| 01C8 0110 | RXBUFFEROFFSET | Receive Buffer Offset Register |
| 01C8 0114 | RXFILTERLOWTHRESH | Receive Filter Low Priority Packets Threshold Register |
| 01C8 0118 – 01C8 011F | – | Reserved |
| 01C8 0120 | RX0FLOWTHRESH | Receive Channel 0 Flow Control Threshold Register |
| 01C8 0124 | RX1FLOWTHRESH | Reserved. Do not write. |
| 01C8 0128 | RX2FLOWTHRESH | |
| 01C8 012C | RX3FLOWTHRESH | |
| 01C8 0130 | RX4FLOWTHRESH | |
| 01C8 0134 | RX5FLOWTHRESH | |
| 01C8 0138 | RX6FLOWTHRESH | |
| 01C8 013C | RX7FLOWTHRESH | |
| 01C8 0140 | RX0FREEBUFFER | |
| 01C8 0144 | RX1FREEBUFFER | Reserved. Do not write. |
| 01C8 0148 | RX2FREEBUFFER | |
| 01C8 014C | RX3FREEBUFFER | |
| 01C8 0150 | RX4FREEBUFFER | |
| 01C8 0154 | RX5FREEBUFFER | |
| 01C8 0158 | RX6FREEBUFFER | |
| 01C8 015C | RX7FREEBUFFER | |

Table 1–9. Ethernet MAC (EMAC) Control Registers (Continued)

| HEX ADDRESS RANGE | ACRONYM | REGISTER NAME |
|-----------------------|------------------|--|
| 01C8 0160 | MACCONTROL | MAC Control Register |
| 01C8 0164 | MACSTATUS | MAC Status Register (RXQOSACT field is reserved.) |
| 01C8 0168 – 01C8 016C | – | Reserved |
| 01C8 0170 | TXINTSTATRAW | Transmit Interrupt Status (Unmasked) Register |
| 01C8 0174 | TXINTSTATMASKED | Transmit Interrupt Status (Masked) Register |
| 01C8 0178 | TXINTMASKSET | Transmit Interrupt Mask Set Register |
| 01C8 017C | TXINTMASKCLEAR | Transmit Interrupt Mask Clear Register |
| 01C8 0180 | MACINVECTOR | MAC Input Vector Register |
| 01C8 0184 – 01C8 018F | – | Reserved |
| 01C8 0190 | RXINTSTATRAW | Receive Interrupt Status (Unmasked) Register (Bits 7–1 are reserved.) |
| 01C8 0194 | RXINTSTATMASKED | Receive Interrupt Status (Masked) Register (Bits 7–1 are reserved.) |
| 01C8 0198 | RXINTMASKSET | Receive Interrupt Mask Set Register (Bits 7–1 are reserved and only support writes of 0.) |
| 01C8 019C | RXINTMASKCLEAR | Receive Interrupt Mask Clear Register (Bits 7–1 are reserved and only support writes of 0.) |
| 01C8 01A0 | MACINTSTATRAW | MAC Interrupt Status (Unmasked) Register |
| 01C8 01A4 | MACINTSTATMASKED | MAC Interrupt Status (Masked) Register |
| 01C8 01A8 | MACINTMASKSET | MAC Interrupt Mask Set Register |
| 01C8 01AC | MACINTMASKCLEAR | MAC Interrupt Mask Clear Register |
| 01C8 01B0 | MACADDRL0 | MAC Address Channel 0 Lower Byte Register |
| 01C8 01B4 | MACADDRL1 | Reserved. Do not write. |
| 01C8 01B8 | MACADDRL2 | |
| 01C8 01BC | MACADDRL3 | |
| 01C8 01C0 | MACADDRL4 | |
| 01C8 01C4 | MACADDRL5 | |
| 01C8 01C8 | MACADDRL6 | |
| 01C8 01CC | MACADDRL7 | |
| 01C8 01D0 | MACADDRM | |
| 01C8 01D4 | MACADDRH | MAC Address High Bytes Register |
| 01C8 01D8 | MACHASH1 | MAC Address Hash 1 Register |
| 01C8 01DC | MACHASH2 | MAC Address Hash 2 Register |
| 01C8 01E0 | BOFFTEST | Backoff Test Register |
| 01C8 01E4 | TPACETEST | Transmit Pacing Test Register |
| 01C8 01E8 | RXPAUSE | Receive Pause Timer Register |
| 01C8 01EC | TXPAUSE | Transmit Pause Timer Register |
| 01C8 01F0 – 01C8 01FF | – | Reserved |
| 01C8 0200 – 01C8 05FF | (see Table 1–10) | EMAC Statistics Registers |
| 01C8 0600 | TX0HDP | Transmit Channel 0 DMA Head Descriptor Pointer Register |
| 01C8 0604 | TX1HDP | Transmit Channel 1 DMA Head Descriptor Pointer Register |
| 01C8 0608 | TX2HDP | Transmit Channel 2 DMA Head Descriptor Pointer Register |
| 01C8 060C | TX3HDP | Transmit Channel 3 DMA Head Descriptor Pointer Register |
| 01C8 0610 | TX4HDP | Transmit Channel 4 DMA Head Descriptor Pointer Register |

Table 1–9. Ethernet MAC (EMAC) Control Registers (Continued)

| HEX ADDRESS RANGE | ACRONYM | REGISTER NAME |
|-----------------------|-----------|---|
| 01C8 0614 | TX5HDP | Transmit Channel 5 DMA Head Descriptor Pointer Register |
| 01C8 0618 | TX6HDP | Transmit Channel 6 DMA Head Descriptor Pointer Register |
| 01C8 061C | TX7HDP | Transmit Channel 7 DMA Head Descriptor Pointer Register |
| 01C8 0620 | RX0HDP | Receive Channel 0 DMA Head Descriptor Pointer Register |
| 01C8 0624 | RX1HDP | Reserved. Do not write. |
| 01C8 0628 | RX2HDP | |
| 01C8 062C | RX3HDP | |
| 01C8 0630 | RX4HDP | |
| 01C8 0634 | RX5HDP | |
| 01C8 0638 | RX6HDP | |
| 01C8 063C | RX7HDP | |
| 01C8 0640 | TX0INTACK | Transmit Channel 0 Interrupt Acknowledge Register |
| 01C8 0644 | TX1INTACK | Transmit Channel 1 Interrupt Acknowledge Register |
| 01C8 0648 | TX2INTACK | Transmit Channel 2 Interrupt Acknowledge Register |
| 01C8 064C | TX3INTACK | Transmit Channel 3 Interrupt Acknowledge Register |
| 01C8 0650 | TX4INTACK | Transmit Channel 4 Interrupt Acknowledge Register |
| 01C8 0654 | TX5INTACK | Transmit Channel 5 Interrupt Acknowledge Register |
| 01C8 0658 | TX6INTACK | Transmit Channel 6 Interrupt Acknowledge Register |
| 01C8 065C | TX7INTACK | Transmit Channel 7 Interrupt Acknowledge Register |
| 01C8 0660 | RX0INTACK | Receive Channel 0 Interrupt Acknowledge Register |
| 01C8 0664 | RX1INTACK | Reserved. Do not write. |
| 01C8 0668 | RX2INTACK | |
| 01C8 066C | RX3INTACK | |
| 01C8 0670 | RX4INTACK | |
| 01C8 0674 | RX5INTACK | |
| 01C8 0678 | RX6INTACK | |
| 01C8 067C | RX7INTACK | |
| 01C8 0680 – 01C8 0FFF | – | Reserved |

Table 1–10. EMAC Statistics Registers

| HEX ADDRESS RANGE | ACRONYM | REGISTER NAME | |
|-----------------------|-------------------|--|--|
| 01C8 0200 | RXGOODFRAMES | Good Receive Frames Register | |
| 01C8 0204 | RXBROADCASTFRAMES | Broadcast Receive Frames Register | |
| 01C8 0208 | RXMCASTFRAMES | Multicast Receive Frames Register | |
| 01C8 020C | RXPAUSEFRAMES | Pause Receive Frames Register | |
| 01C8 0210 | RXCRCERRORS | Receive CRC Errors Register | |
| 01C8 0214 | RXALIGNCODEERRORS | Receive Alignment/Code Errors Register | |
| 01C8 0218 | RXOVERSIZED | Receive Oversized Frames Register | |
| 01C8 021C | RXJABBER | Receive Jabber Frames Register | |
| 01C8 0220 | RXUNDERSIZED | Receive Undersized Frames Register | |
| 01C8 0224 | RXFRAGMENTS | Receive Frame Fragments Register | |
| 01C8 0228 | RXFILTERED | Filtered Receive Frames Register | |
| 01C8 022C | RXQOSFILTERED | Reserved | |
| 01C8 0230 | RXOCTETS | Receive Octet Frames Register | |
| 01C8 0234 | TXGOODFRAMES | Good Transmit Frames Register | |
| 01C8 0238 | TXBROADCASTFRAMES | Broadcast Transmit Frames Register | |
| 01C8 023C | TXMCASTFRAMES | Multicast Transmit Frames Register | |
| 01C8 0240 | TXPAUSEFRAMES | Pause Transmit Frames Register | |
| 01C8 0244 | TXDEFERRED | Deferred Transmit Frames Register | |
| 01C8 0248 | TXCOLLISION | Collision Register | |
| 01C8 024C | TXSINGLECOLL | Single Collision Transmit Frames Register | |
| 01C8 0250 | TXMULTICOLL | Multiple Collision Transmit Frames Register | |
| 01C8 0254 | TXEXCESSIVECOLL | Excessive Collisions Register | |
| 01C8 0258 | TXLATECOLL | Late Collisions Register | |
| 01C8 025C | TXUNDERRUN | Transmit Underrun Register | |
| 01C8 0260 | TXCARRIERSLOSS | Transmit Carrier Sense Errors Register | |
| 01C8 0264 | TXOCTETS | Transmit Octet Frames Register | |
| 01C8 0268 | FRAME64 | Transmit and Receive 64 Octet Frames Register | |
| 01C8 026C | FRAME65T127 | Transmit and Receive 65 to 127 Octet Frames Register | |
| 01C8 0270 | FRAME128T255 | Transmit and Receive 128 to 255 Octet Frames Register | |
| 01C8 0274 | FRAME256T511 | Transmit and Receive 256 to 511 Octet Frames Register | |
| 01C8 0278 | FRAME512T1023 | Transmit and Receive 512 to 1023 Octet Frames Register | |
| 01C8 027C | FRAME1024TUP | Transmit and Receive 1024 or Above Octet Frames Register | |
| 01C8 0280 | NETOCTETS | Network Octet Frames Register | |
| 01C8 0284 | RXSOFOVERRUNS | Receive Start of Frame Overruns Register | |
| 01C8 0288 | RXMOFOVERRUNS | Receive Middle of Frame Overruns Register | |
| 01C8 028C | RXDMAOVERRUNS | Receive DMA Overruns Register | |
| 01C8 0290 – 01C8 05FF | – | Reserved | |

Table 1–11. EMAC Wrapper

| HEX ADDRESS RANGE | ACRONYM | REGISTER NAME |
|-----------------------|---------|---------------------------------------|
| 01C8 1000 – 01C8 1FFF | | EMAC Control Module Descriptor Memory |
| 01C8 2000 – 01C8 2FFF | – | Reserved |

Table 1–12. EWRAP Registers

| HEX ADDRESS RANGE | ACRONYM | REGISTER NAME |
|-----------------------|-----------|----------------------------|
| 01C8 3000 | EWTRCTRL | TR control |
| 01C8 3004 | EWCTL | Interrupt control register |
| 01C8 3008 | EWINTTCNT | Interrupt timer count |
| 01C8 300C – 01C8 37FF | – | Reserved |

Table 1–13. Device Configuration Registers

| HEX ADDRESS RANGE | ACRONYM | REGISTER NAME | COMMENTS |
|-----------------------|----------|--|--|
| 01B3 F000 | PERCFG | Peripheral Configuration Register | Enables or disables specific peripherals. This register is also used for power-down of disabled peripherals. |
| 01B3 F004 | DEVSTAT | Device Status Register | Read-only. Provides status of the User's device configuration on reset. |
| 01B3 F008 | JTAGID | JTAG Identification Register | Read-only. Provides 32-bit JTAG ID of the device. |
| 01B3 F00C – 01B3 F014 | – | Reserved | |
| 01B3 F018 | PCFGLOCK | Peripheral Configuration Lock Register | |
| 01B3 F01C – 01B3 FFFF | – | Reserved | |

Table 1–14. McBSP 0 Registers

| HEX ADDRESS RANGE | ACRONYM | REGISTER NAME | COMMENTS |
|---------------------------|---------|---|---|
| 018C 0000 | DRR0 | McBSP0 data receive register via Configuration Bus | The CPU and EDMA controller can only read this register; they cannot write to it. |
| 0x3000 0000 – 0x33FF FFFF | DRR0 | McBSP0 data receive register via Peripheral Bus | |
| 018C 0004 | DXR0 | McBSP0 data transmit register via Configuration Bus | |
| 0x3000 0000 – 0x33FF FFFF | DXR0 | McBSP0 data transmit register via Peripheral Bus | |
| 018C 0008 | SPCR0 | McBSP0 serial port control register | |
| 018C 000C | RCR0 | McBSP0 receive control register | |
| 018C 0010 | XCR0 | McBSP0 transmit control register | |
| 018C 0014 | SRGR0 | McBSP0 sample rate generator register | |
| 018C 0018 | MCR0 | McBSP0 multichannel control register | |
| 018C 001C | RCERE00 | McBSP0 enhanced receive channel enable register 0 | |
| 018C 0020 | XCERE00 | McBSP0 enhanced transmit channel enable register 0 | |
| 018C 0024 | PCR0 | McBSP0 pin control register | |
| 018C 0028 | RCERE10 | McBSP0 enhanced receive channel enable register 1 | |
| 018C 002C | XCERE10 | McBSP0 enhanced transmit channel enable register 1 | |
| 018C 0030 | RCERE20 | McBSP0 enhanced receive channel enable register 2 | |
| 018C 0034 | XCERE20 | McBSP0 enhanced transmit channel enable register 2 | |
| 018C 0038 | RCERE30 | McBSP0 enhanced receive channel enable register 3 | |
| 018C 003C | XCERE30 | McBSP0 enhanced transmit channel enable register 3 | |
| 018C 0040 – 018F FFFF | – | Reserved | |

Table 1–15. McBSP 1 Registers

| HEX ADDRESS RANGE | ACRONYM | REGISTER NAME | COMMENTS |
|---------------------------|---------|---|---|
| 0190 0000 | DRR1 | McBSP1 data receive register via Configuration Bus | The CPU and EDMA controller can only read this register; they cannot write to it. |
| 0x3400 0000 – 0x37FF FFFF | DRR1 | McBSP1 data receive register via peripheral bus | |
| 0190 0004 | DXR1 | McBSP1 data transmit register via configuration bus | |
| 0x3400 0000 – 0x37FF FFFF | DXR1 | McBSP1 data transmit register via peripheral bus | |
| 0190 0008 | SPCR1 | McBSP1 serial port control register | |
| 0190 000C | RCR1 | McBSP1 receive control register | |
| 0190 0010 | XCR1 | McBSP1 transmit control register | |
| 0190 0014 | SRGR1 | McBSP1 sample rate generator register | |
| 0190 0018 | MCR1 | McBSP1 multichannel control register | |
| 0190 001C | RCERE01 | McBSP1 enhanced receive channel enable register 0 | |
| 0190 0020 | XCERE01 | McBSP1 enhanced transmit channel enable register 0 | |
| 0190 0024 | PCR1 | McBSP1 pin control register | |
| 0190 0028 | RCERE11 | McBSP1 enhanced receive channel enable register 1 | |
| 0190 002C | XCERE11 | McBSP1 enhanced transmit channel enable register 1 | |
| 0190 0030 | RCERE21 | McBSP1 enhanced receive channel enable register 2 | |
| 0190 0034 | XCERE21 | McBSP1 enhanced transmit channel enable register 2 | |
| 0190 0038 | RCERE31 | McBSP1 enhanced receive channel enable register 3 | |
| 0190 003C | XCERE31 | McBSP1 enhanced transmit channel enable register 3 | |
| 0190 0040 – 0193 FFFF | – | Reserved | |

Table 1–16. Timer 0 Registers

| HEX ADDRESS RANGE | ACRONYM | REGISTER NAME | COMMENTS |
|-----------------------|---------|--------------------------|---|
| 0194 0000 | CTL0 | Timer 0 control register | Determines the operating mode of the timer, monitors the timer status, and controls the function of the TOUT pin. |
| 0194 0004 | PRD0 | Timer 0 period register | Contains the number of timer input clock cycles to count. This number controls the TSTAT signal frequency. |
| 0194 0008 | CNT0 | Timer 0 counter register | Contains the current value of the incrementing counter. |
| 0194 000C – 0197 FFFF | – | Reserved | |

Table 1–17. Timer 1 Registers

| HEX ADDRESS RANGE | ACRONYM | REGISTER NAME | COMMENTS |
|-----------------------|---------|--------------------------|---|
| 0198 0000 | CTL1 | Timer 1 control register | Determines the operating mode of the timer, monitors the timer status, and controls the function of the TOUT pin. |
| 0198 0004 | PRD1 | Timer 1 period register | Contains the number of timer input clock cycles to count. This number controls the TSTAT signal frequency. |
| 0198 0008 | CNT1 | Timer 1 counter register | Contains the current value of the incrementing counter. |
| 0198 000C – 019B FFFF | – | Reserved | |

Table 1–18. Timer 2 Registers

| HEX ADDRESS RANGE | ACRONYM | REGISTER NAME | COMMENTS |
|-----------------------|---------|--------------------------|--|
| 01AC 0000 | CTL2 | Timer 2 control register | Determines the operating mode of the timer, monitors the timer status. |
| 01AC 0004 | PRD2 | Timer 2 period register | Contains the number of timer input clock cycles to count. This number controls the TSTAT signal frequency. |
| 01AC 0008 | CNT2 | Timer 2 counter register | Contains the current value of the incrementing counter. |
| 01AC 000C – 01AF FFFF | – | Reserved | |

Table 1–19. HPI Registers

| HEX ADDRESS RANGE | ACRONYM | REGISTER NAME | COMMENTS |
|-----------------------|------------------------------|---------------------------------------|--|
| – | HPID | HPI data register | Host read/write access only |
| 0188 0000 | HPIC | HPI control register | HPIC has both Host/CPU read/write access |
| 0188 0004 | HPIA (HPIAW) [†] | HPI address register (Write) | HPIA has both Host/CPU read/write access |
| 0188 0008 | HPIA (HPIAR) [†] | HPI address register (Read) | |
| 0188 000C – 0189 FFFF | – | Reserved | |
| 018A 0000 | HPI_TRCTL | HPI transfer request control register | |
| 018A 0004 – 018B FFFF | – | Reserved | |

[†] Host access to the HPIA register updates both the HPIAW and HPIAR registers. The CPU can access HPIAW and HPIAR independently.

Table 1–20. GP0 Registers

| HEX ADDRESS RANGE | ACRONYM | REGISTER NAME |
|-----------------------|---------|---------------------------------|
| 01B0 0000 | GPEN | GP0 enable register |
| 01B0 0004 | GPDIR | GP0 direction register |
| 01B0 0008 | GPVAL | GP0 value register |
| 01B0 000C | – | Reserved |
| 01B0 0010 | GPDH | GP0 delta high register |
| 01B0 0014 | GPHM | GP0 high mask register |
| 01B0 0018 | GPDH | GP0 delta low register |
| 01B0 001C | GPLM | GP0 low mask register |
| 01B0 0020 | GPGC | GP0 global control register |
| 01B0 0024 | GPPOL | GP0 interrupt polarity register |
| 01B0 0028 – 01B3 EFFF | – | Reserved |

Table 1–21. PCI Peripheral Registers

| HEX ADDRESS RANGE | ACRONYM | REGISTER NAME |
|-----------------------|-----------|---------------------------------------|
| 01C0 0000 | RSTSRC | DSP Reset source/status register |
| 01C0 0004 | – | Reserved |
| 01C0 0008 | PCIIS | PCI interrupt source register |
| 01C0 000C | PCIEN | PCI interrupt enable register |
| 01C0 0010 | DSPMA | DSP master address register |
| 01C0 0014 | PCIMA | PCI master address register |
| 01C0 0018 | PCIMC | PCI master control register |
| 01C0 001C | CDSPA | Current DSP address register |
| 01C0 0020 | CPCIA | Current PCI address register |
| 01C0 0024 | CCNT | Current byte count register |
| 01C0 0028 | – | Reserved |
| 01C0 002C – 01C1 FFEF | – | Reserved |
| 0x01C1 FFF0 | HSR | Host status register |
| 0x01C1 FFF4 | HDCR | Host-to-DSP control register |
| 0x01C1 FFF8 | DSPP | DSP page register |
| 0x01C1 FFFC | – | Reserved |
| 01C2 0000 | EEADD | EEPROM address register |
| 01C2 0004 | EEDAT | EEPROM data register |
| 01C2 0008 | EECTL | EEPROM control register |
| 01C2 000C – 01C2 FFFF | – | Reserved |
| 01C3 0000 | PCI_TRCTL | PCI transfer request control register |
| 01C3 0004 – 01C3 FFFF | – | Reserved |

Table 1–22. MDIO Registers

| HEX ADDRESS RANGE | ACRONYM | REGISTER NAME |
|-----------------------|------------------|---|
| 01C8 3800 | VERSION | MDIO Version Register |
| 01C8 3804 | CONTROL | MDIO Control Register |
| 01C8 3808 | ALIVE | MDIO PHY Alive Indication Register |
| 01C8 380C | LINK | MDIO PHY Link Status Register |
| 01C8 3810 | LINKINTRAW | MDIO Link Status Change Interrupt Register (MAC1 field is reserved and only supports writes of 0.) |
| 01C8 3814 | LINKINTMASKED | MDIO Link Status Change Interrupt (Masked) Register (MAC1 field is reserved and only supports writes of 0.) |
| 01C8 3818 – 01C8 381F | – | Reserved |
| 01C8 3820 | USERINTRAW | MDIO User Command Complete Interrupt Register (MAC1 field is reserved and only supports writes of 0.) |
| 01C8 3824 | USERINTMASKED | MDIO User Command Complete Interrupt (Masked) Register (MAC1 field is reserved and only supports writes of 0.) |
| 01C8 3828 | USERINTMASKSET | MDIO User Command Complete Interrupt Mask Set Register (MAC1 field is reserved and only supports writes of 0.) |
| 01C8 382C | USERINTMASKCLEAR | MDIO User Command Complete Interrupt Mask Clear Register (MAC1 field is reserved and only supports writes of 0.) |
| 01C8 3830 – 01C8 387F | – | Reserved |
| 01C8 3880 | USERACCESS0 | MDIO User Access Register 0 |
| 01C8 3884 | USERPHYSEL0 | MDIO User PHY Select Register 0 |
| 01C8 3888 | USERACCESS1 | Reserved. Do not write. |
| 01C8 388C | USERPHYSEL1 | Reserved. Do not write. |
| 01C8 3890 – 01C8 3FFF | – | Reserved |

Table 1–23. I2C0 Registers

| HEX ADDRESS RANGE | ACRONYM | REGISTER NAME |
|-----------------------|----------|--|
| 01B4 0000 | I2COAR0 | I2C0 own address register |
| 01B4 0004 | I2CIER0 | I2C0 interrupt enable register |
| 01B4 0008 | I2CSTR0 | I2C0 interrupt status register |
| 01B4 000C | I2CCLKL0 | I2C0 clock low-time divider register |
| 01B4 0010 | I2CCLKH0 | I2C0 clock high-time divider register |
| 01B4 0014 | I2CCNT0 | I2C0 data count register |
| 01B4 0018 | I2CDRR0 | I2C0 data receive register |
| 01B4 001C | I2CSAR0 | I2C0 slave address register |
| 01B4 0020 | I2CDXR0 | I2C0 data transmit register |
| 01B4 0024 | I2CMDR0 | I2C0 mode register |
| 01B4 0028 | I2CISRC0 | I2C0 interrupt source register |
| 01B4 002C | – | Reserved |
| 01B4 0030 | I2CPSC0 | I2C0 prescaler register |
| 01B4 0034 | I2CPID10 | I2C0 Peripheral Identification register 1 [Value: 0x0000 0101] |
| 01B4 0038 | I2CPID20 | I2C0 Peripheral Identification register 2 [Value: 0x0000 0005] |
| 01B4 003C – 01B4 3FFF | – | Reserved |

1.8 EDMA Channel Synchronization Events

The C64x EDMA supports up to 64 EDMA channels which service peripheral devices and external memory. Table 1–24 lists the source of C64x EDMA synchronization events associated with each of the programmable EDMA channels. For the C6412 device, the association of an event to a channel is fixed; each of the EDMA channels has one specific event associated with it. These specific events are captured in the EDMA event registers (ERL, ERH) even if the events are disabled by the EDMA event enable registers (EERL, EERH). The priority of each event can be specified independently in the transfer parameters stored in the EDMA parameter RAM. For more detailed information on the EDMA module and how EDMA events are enabled, captured, processed, linked, chained, and cleared, etc., see the *TMS320C6000 DSP Enhanced Direct Memory Access (EDMA) Controller Reference Guide* (literature number SPRU234).

Table 1–24. TMS320C6412 EDMA Channel Synchronization Events[†]

| EDMA CHANNEL | EVENT NAME | EVENT DESCRIPTION |
|--------------|-----------------|--------------------------------------|
| 0 | DSP_INT | HPI/PCI-to-DSP interrupt |
| 1 | TINT0 | Timer 0 interrupt |
| 2 | TINT1 | Timer 1 interrupt |
| 3 | SD_INTA | EMIFA SDRAM timer interrupt |
| 4 | GPINT4/EXT_INT4 | GP0 event 4/External interrupt pin 4 |
| 5 | GPINT5/EXT_INT5 | GP0 event 5/External interrupt pin 5 |
| 6 | GPINT6/EXT_INT6 | GP0 event 6/External interrupt pin 6 |
| 7 | GPINT7/EXT_INT7 | GP0 event 7/External interrupt pin 7 |
| 8 | GPINT0 | GP0 event 0 |
| 9 | GPINT1 | GP0 event 1 |
| 10 | GPINT2 | GP0 event 2 |
| 11 | GPINT3 | GP0 event 3 |
| 12 | XEVT0 | McBSP0 transmit event |
| 13 | REVT0 | McBSP0 receive event |
| 14 | XEVT1 | McBSP1 transmit event |
| 15 | REVT1 | McBSP1 receive event |
| 16–18 | – | None |
| 19 | TINT2 | Timer 2 interrupt |
| 20–43 | – | None |
| 44 | ICREVT0 | I2C0 receive event |
| 45 | ICXEVT0 | I2C0 transmit event |
| 46–47 | – | None |
| 48 | GPINT8 | GP0 event 8 |
| 49 | GPINT9 | GP0 event 9 |
| 50 | GPINT10 | GP0 event 10 |
| 51 | GPINT11 | GP0 event 11 |
| 52 | GPINT12 | GP0 event 12 |

[†] In addition to the events shown in this table, each of the 64 channels can also be synchronized with the transfer completion or alternate transfer completion events. For more detailed information on EDMA event-transfer chaining, see the *TMS320C6000 DSP Enhanced Direct Memory Access (EDMA) Controller Reference Guide* (literature number SPRU234).

Table 1–24. TMS320C6412 EDMA Channel Synchronization Events[†] (Continued)

| EDMA CHANNEL | EVENT NAME | EVENT DESCRIPTION |
|--------------|------------|-------------------|
| 53 | GPINT13 | GP0 event 13 |
| 54 | GPINT14 | GP0 event 14 |
| 55 | GPINT15 | GP0 event 15 |
| 56–63 | – | None |

[†] In addition to the events shown in this table, each of the 64 channels can also be synchronized with the transfer completion or alternate transfer completion events. For more detailed information on EDMA event-transfer chaining, see the *TMS320C6000 DSP Enhanced Direct Memory Access (EDMA) Controller Reference Guide* (literature number SPRU234).

1.9 Interrupt Sources and Interrupt Selector

The C64x DSP core supports 16 prioritized interrupts, which are listed in Table 1–25. The highest-priority interrupt is INT_00 (dedicated to RESET) while the lowest-priority interrupt is INT_15. The first four interrupts (INT_00–INT_03) are non-maskable and fixed. The remaining interrupts (INT_04–INT_15) are maskable and default to the interrupt source specified in Table 1–25. The interrupt source for interrupts 4–15 can be programmed by modifying the selector value (binary value) in the corresponding fields of the Interrupt Selector Control registers: MUXH (address 0x019C0000) and MUXL (address 0x019C0004).

Table 1–25. C6412 DSP Interrupts

| CPU INTERRUPT NUMBER | INTERRUPT SELECTOR CONTROL REGISTER | SELECTOR VALUE (BINARY) | INTERRUPT EVENT | INTERRUPT SOURCE |
|----------------------|-------------------------------------|-------------------------|-----------------|--|
| INT_00 [†] | – | – | RESET | |
| INT_01 [†] | – | – | NMI | |
| INT_02 [†] | – | – | Reserved | Reserved. Do not use. |
| INT_03 [†] | – | – | Reserved | Reserved. Do not use. |
| INT_04 [‡] | MUXL[4:0] | 00100 | GPINT4/EXT_INT4 | GP0 interrupt 4/External interrupt pin 4 |
| INT_05 [‡] | MUXL[9:5] | 00101 | GPINT5/EXT_INT5 | GP0 interrupt 5/External interrupt pin 5 |
| INT_06 [‡] | MUXL[14:10] | 00110 | GPINT6/EXT_INT6 | GP0 interrupt 6/External interrupt pin 6 |
| INT_07 [‡] | MUXL[20:16] | 00111 | GPINT7/EXT_INT7 | GP0 interrupt 7/External interrupt pin 7 |
| INT_08 [‡] | MUXL[25:21] | 01000 | EDMA_INT | EDMA channel (0 through 63) interrupt |
| INT_09 [‡] | MUXL[30:26] | 01001 | EMU_DTDMA | EMU DTDMA |
| INT_10 [‡] | MUXH[4:0] | 00011 | SD_INTA | EMIFA SDRAM timer interrupt |
| INT_11 [‡] | MUXH[9:5] | 01010 | EMU_RTDXR | EMU real-time data exchange (RTDX) receive |
| INT_12 [‡] | MUXH[14:10] | 01011 | EMU_RTDXTX | EMU RTDX transmit |
| INT_13 [‡] | MUXH[20:16] | 00000 | DSP_INT | HPI/PCI-to-DSP interrupt |
| INT_14 [‡] | MUXH[25:21] | 00001 | TINT0 | Timer 0 interrupt |
| INT_15 [‡] | MUXH[30:26] | 00010 | TINT1 | Timer 1 interrupt |
| – | – | 01100 | XINT0 | McBSP0 transmit interrupt |
| – | – | 01101 | RINT0 | McBSP0 receive interrupt |
| – | – | 01110 | XINT1 | McBSP1 transmit interrupt |
| – | – | 01111 | RINT1 | McBSP1 receive interrupt |
| – | – | 10000 | GPINT0 | GP0 interrupt 0 |
| – | – | 10001 | Reserved | Reserved. Do not use. |
| – | – | 10010 | Reserved | Reserved. Do not use. |
| – | – | 10011 | TINT2 | Timer 2 interrupt |
| – | – | 10100 | Reserved | Reserved. Do not use. |
| – | – | 10101 | Reserved | Reserved. Do not use. |
| – | – | 10110 | ICINT0 | I2C0 interrupt |
| – | – | 10111 | Reserved | Reserved. Do not use. |
| – | – | 11000 | EMAC_MDIO_INT | EMAC/MDIO interrupt |
| – | – | 11001 – 11111 | Reserved | Reserved. Do not use. |

[†] Interrupts INT_00 through INT_03 are non-maskable and fixed.

[‡] Interrupts INT_04 through INT_15 are programmable by modifying the binary selector values in the Interrupt Selector Control registers fields. Table 1–25 shows the default interrupt sources for Interrupts INT_04 through INT_15. For more detailed information on interrupt sources and selection, see the *TMS320C6000 DSP Interrupt Selector Reference Guide* (literature number SPRU646).

1.10 Signal Groups Description

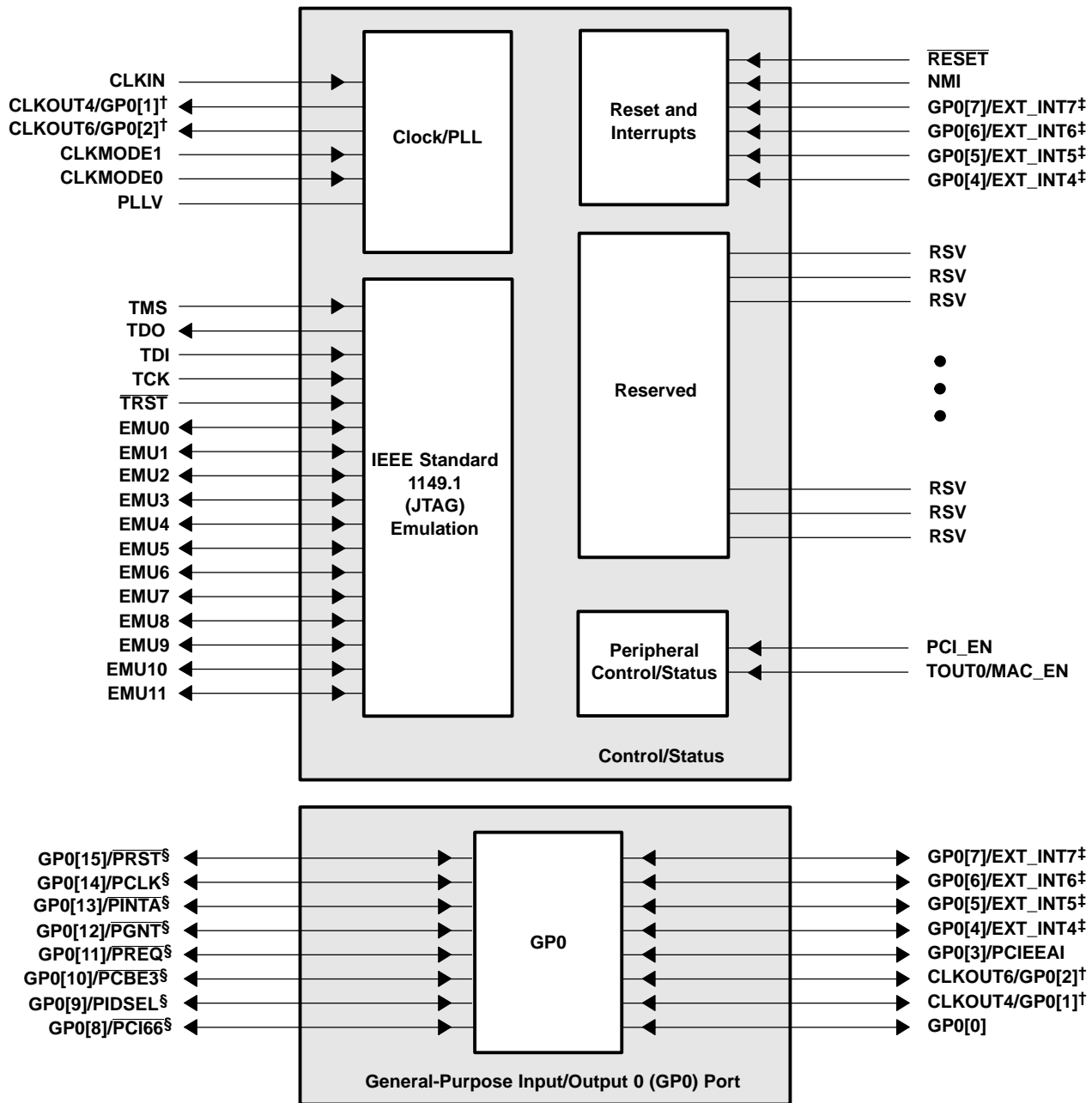

† These pins are muxed with the GP0 pins and by default these signals function as clocks (CLKOUT4 or CLKOUT6). To use these muxed pins as GPIO signals, the appropriate GPIO register bits (GPxEN and GPxDIR) must be properly enabled and configured. For more details, see the Device Configurations section of this data sheet.

‡ These pins are GP0 pins that can also function as external interrupt sources (EXT_INT[7:4]). Default after reset is EXT_INTx or GPIO as input-only.

§ These GP0 pins are muxed with the PCI peripheral pins and by default these signals are set up to no function with both the GPIO and PCI pin functions disabled. For more details on these muxed pins, see the Device Configurations section of this data sheet.

Figure 1–6. CPU and Peripheral Signals

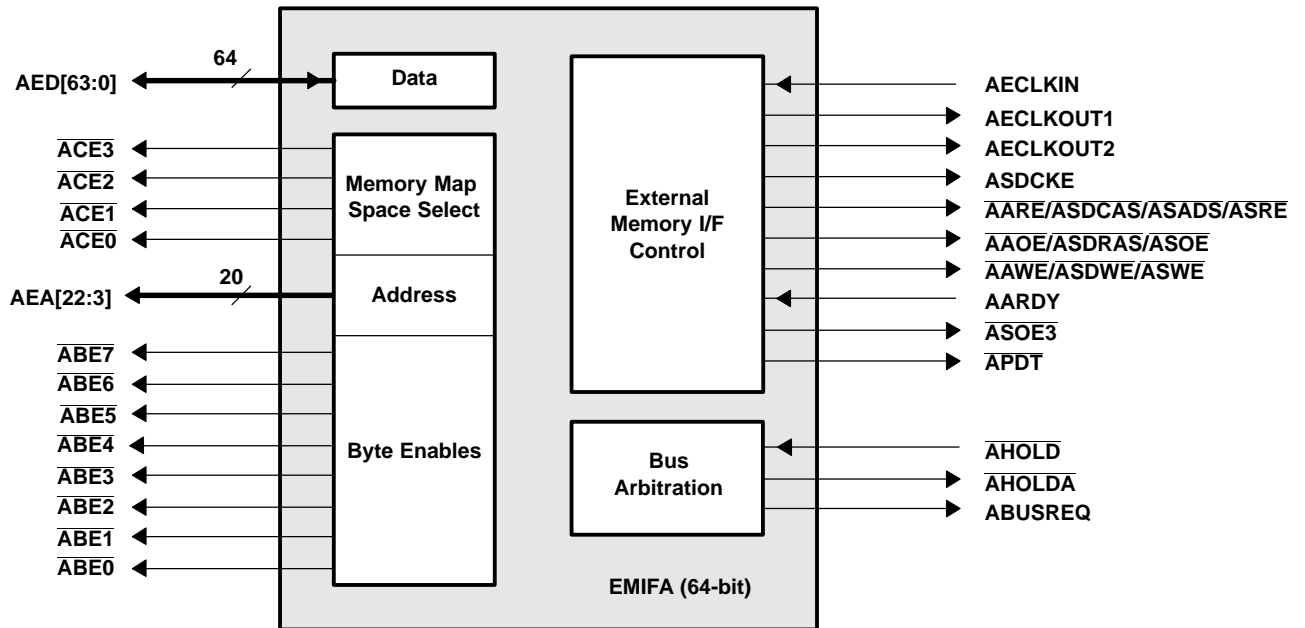
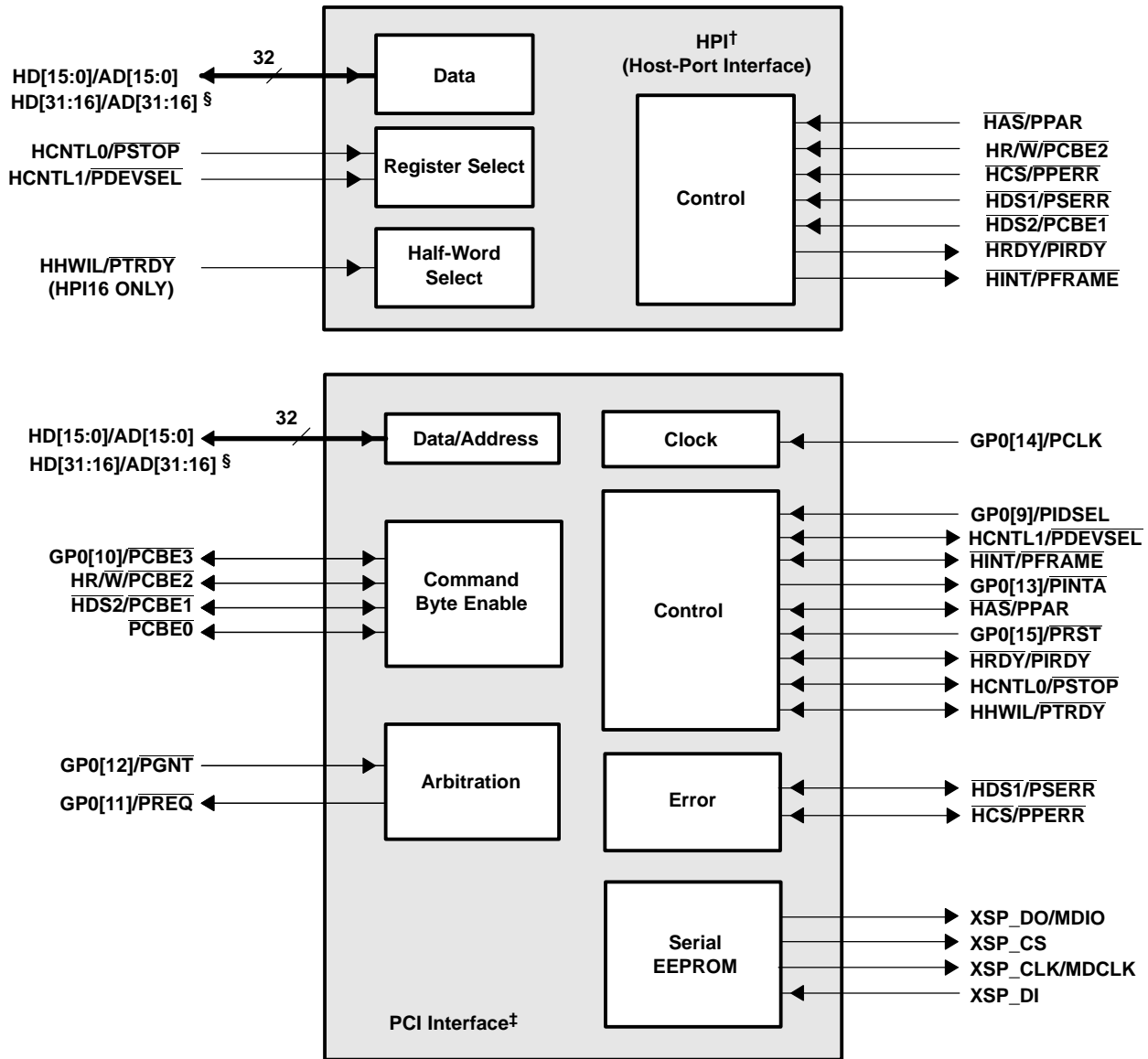

Figure 1–7. Peripheral Signals



† These HPI pins are muxed with the PCI peripheral. By default, these signals function as HPI. For more details on these muxed pins, see the Device Configurations section of this data sheet.

‡ These PCI pins (excluding PCBE0 and XSP_CS) are muxed with the HPI or MDIO or GP0 peripherals. By default, these signals function as HPI and no function, respectively. For more details on these muxed pins, see the Device Configurations section of this data sheet.

§ These HPI/PCI data pins (HD[31:16]/AD[31:16]) are muxed with the EMAC peripheral. By default, these pins function as HPI. For more details on the EMAC pin functions, see the Ethernet MAC (EMAC) peripheral signals section and the terminal functions table portions of this data sheet.

Figure 1-7. Peripheral Signals (Continued)

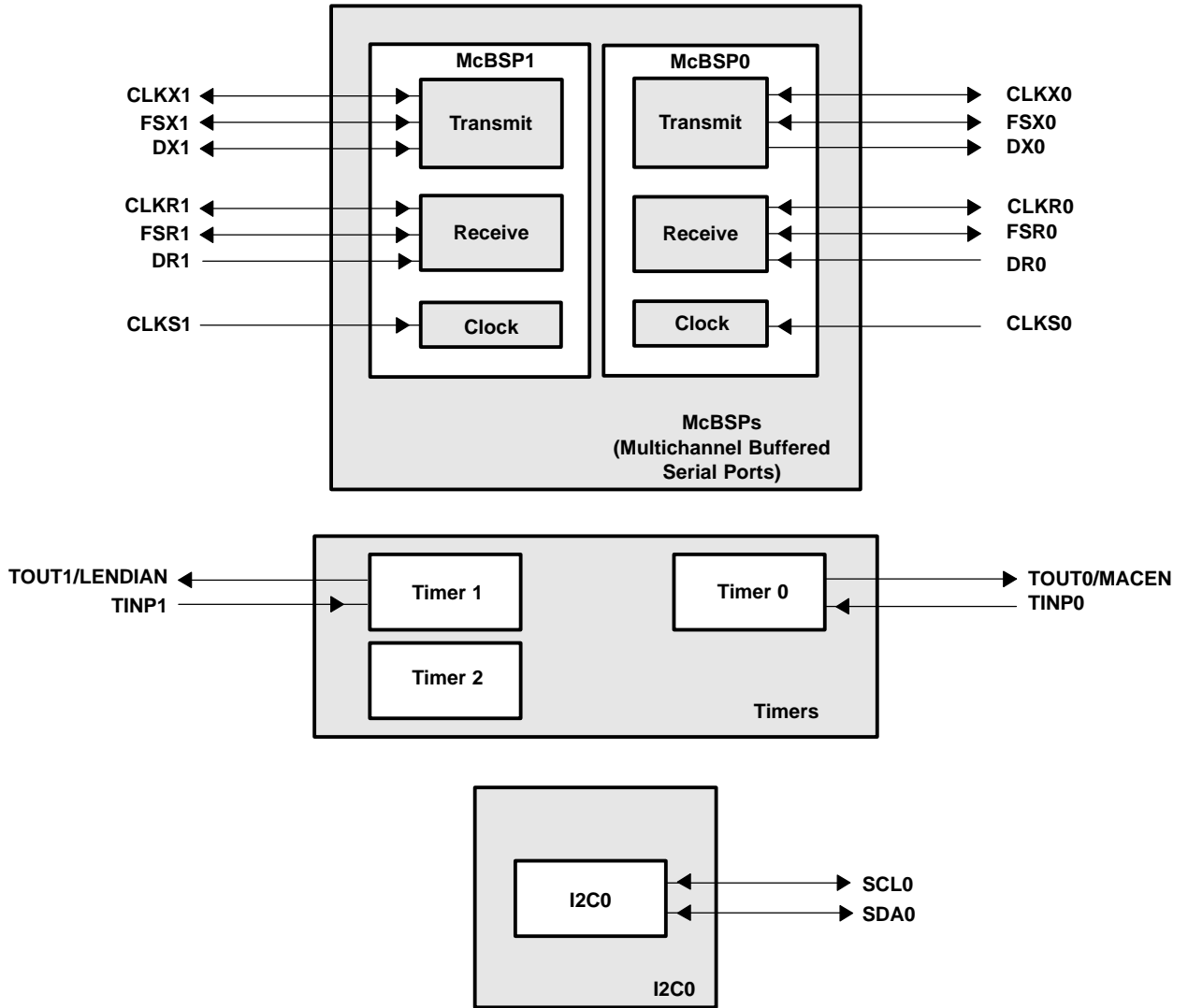
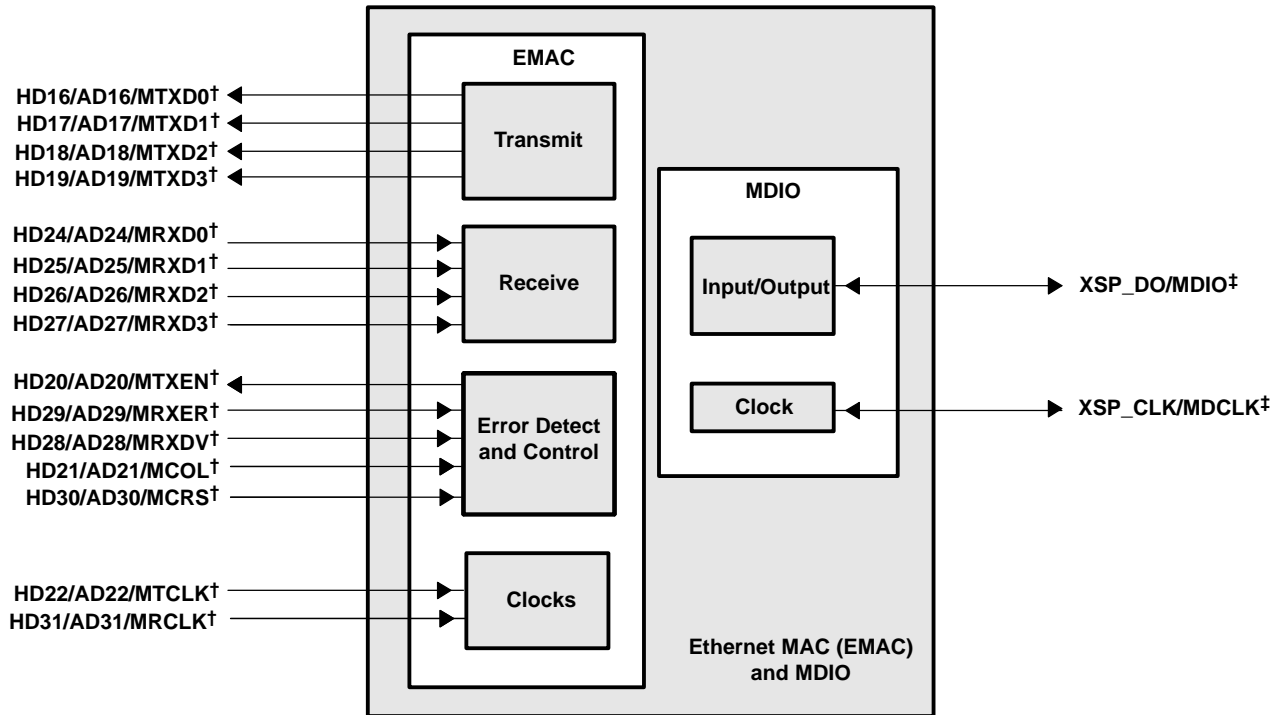

Figure 1-7. Peripheral Signals (Continued)



† These EMAC pins are muxed with the upper data pins of the HPI or PCI peripherals. By default, these signals function as HPI. For more details on these muxed pins, see the Device Configurations section of this data sheet.

‡ These MDIO pins are muxed with the PCI peripherals. By default, these signals function as PCI. For more details on these muxed pins, see the Device Configurations section of this data sheet.

Figure 1–7. Peripheral Signals (Continued)

2 Device Configurations

On the C6412 device, bootmode and certain device configurations/peripheral selections are determined at device reset, while other device configurations/peripheral selections are software-configurable via the peripheral configurations register (PERCFG) [address location 0x01B3F000] after device reset.

2.1 Peripheral Selection at Device Reset

Some C6412 peripherals share the same pins (internally muxed) and are mutually exclusive (i.e., HPI, general-purpose input/output pins GP0[15:9], PCI and its internal EEPROM, EMAC, and MDIO). Other C6412 peripherals (i.e., the Timers, I2C0, and the GP0[7:0] pins), are always available.

- HPI, GP0[15:9], PCI, EEPROM (internal to PCI), and EMAC peripherals

The PCI_EN and MAC_EN pins are latched at reset. They determine specific peripheral selection, summarized in Table 2–1.

Table 2–1. PCI_EN, HD5, and MAC_EN Peripheral Selection (HPI, GP0[15:9], PCI, EMAC, and MDIO)

| PERIPHERAL SELECTION | | | | PERIPHERALS SELECTED | | | | | |
|----------------------|-------------------|--------------|-----------------|----------------------|----------------|------------|-------------------------------|---------------|-----------|
| PCI_EN Pin [E2] | PCI_EEAI Pin [L5] | HD5 Pin [Y1] | MAC_EN Pin [C5] | HPI Data Lower | HPI Data Upper | 32-Bit PCI | EEPROM (Auto-Init) | EMAC and MDIO | GP0[15:9] |
| 0 | 0 | 0 | 0 | √ | Hi-Z | Disabled | N/A | Disabled | √ |
| 0 | 0 | 0 | 1 | √ | Hi-Z | Disabled | N/A | √ | √ |
| 0 | 0 | 1 | 0 | √ | √ | Disabled | N/A | Disabled | √ |
| 0 | 0 | 1 | 1 | Disabled | | Disabled | N/A | √ | √ |
| 1 | 1 | X | X | Disabled | | √ | Enabled (via External EEPROM) | Disabled | Disabled |
| 1 | 0 | X | X | Disabled | | √ | Disabled (default values) | Disabled | Disabled |

- If the PCI is disabled (PCI_EN = 0), the HPI peripheral is enabled and based on the HD5 and MAC_EN pin configuration at reset, HPI16 mode or EMAC and MDIO can be selected. When the PCI is disabled (PCI_EN = 0), the GP0[15:9] pins can also be programmed as GPIO, provided the GPxEN and GPxDIR bits are properly configured.

This means all multiplexed HPI/PCI pins function as HPI and all standalone PCI pins (PCBE0 and XSP_CS) are tied-off (Hi-Z). Also, the multiplexed GP0/PCI pins can be used as GPIO with the proper software configuration of the GPIO enable and direction registers (for more details, see Table 2–9).

- If the PCI is enabled (PCI_EN = 1), the HPI peripheral is disabled.
This means all multiplexed HPI/PCI pins function as PCI. Also, the multiplexed GP0/PCI pins function as PCI pins (for more details, see Table 2–9).
- The MAC_EN pin, in combination with the PCI_EN and HD5 pins, controls the selection of the EMAC and MDIO peripherals (for more details, see Table 2–2).
- The PCI_EN pin (= 1) and the PCI_EEAI pin control the whether the PCI initializes its internal registers via external EEPROM (PCI_EEAI = 1) or if the internal default values are used instead (PCI_EEAI = 0).

Table 2–2. HPI vs. EMAC Peripheral Pin Selection

| CONFIGURATION SELECTION | | | PERIPHERALS SELECTED | |
|-------------------------|--------------|-----------------|---|---------------|
| GP0[0] Pin [M5]† | HD5 Pin [Y1] | MAC_EN Pin [C5] | HD[15:0] | HD[31:16] |
| 0 | 0 | 0 | HPI16 | Hi-Z |
| 0 | 0 | 1 | HPI16 | used for EMAC |
| 0 | 1 | 0 | HPI32 (HD[31:0]) | |
| 0 | 1 | 1 | Hi-Z | used for EMAC |
| 1 | X | X | Invalid configuration: The GP0[0] pin must remain low during device reset. | |

2.2 Device Configuration at Device Reset

Table 2–3 describes the C6412 device configuration pins, which are set up via external pullup/pulldown resistors through the specified EMIFA address bus pins (AEA[22:19]), and the TOUT1/LENDIAN, GP0[3]/PCIEEAI, and the HD5 pins (all of which are latched during device reset).

Table 2–3. C6412 Device Configuration Pins (TOUT1/LENDIAN, AEA[22:19], GP0[3]/PCIEEAI, GP0[8]/PCI66, HD5/AD5, PCI_EN, and TOUT0/MAC_EN)

| CONFIGURATION PIN | NO. | FUNCTIONAL DESCRIPTION |
|-------------------------|------------|---|
| TOUT1/LENDIAN | B5 | Device Endian mode (LEND) 0 – System operates in Big Endian mode 1 – System operates in Little Endian mode (default) |
| AEA[22:21] | [U23, V24] | Bootmode [1:0] 00 – No boot (default mode) 01 – HPI/PCI boot (based on PCI_EN pin) 10 – Reserved 11 – EMIFA 8-bit ROM boot |
| AEA[20:19] | [V25, V26] | EMIFA input clock select Clock mode select for EMIFA (AECLKIN_SEL[1:0]) 00 – AECLKIN (default mode) 01 – CPU/4 Clock Rate 10 – CPU/6 Clock Rate 11 – Reserved |
| GP0[3]/PCIEEAI | L5 | PCI EEPROM Auto-Initialization (PCIEEAI) PCI auto-initialization via external EEPROM 0 – PCI auto-initialization through EEPROM is disabled; the PCI peripheral uses the specified PCI default values (default). 1 – PCI auto-initialization through EEPROM is enabled; the PCI peripheral is configured through EEPROM provided the PCI peripheral pin is enabled (PCI_EN = 1). Note: If the PCI peripheral is disabled (PCI_EN pin = 0), this pin must not be pulled up. For more information on the PCI EEPROM default values, see the <i>TMS320C6000 DSP Peripheral Component Interconnect (PCI) Reference Guide</i> (literature number SPRU581). |
| GP0[8]/PCI66 | AD1 | PCI frequency selection (PCI66) [PCI peripheral <i>needs</i> be enabled (PCI_EN = 1) to use this function] Selects the PCI operating frequency of 66 MHz or 33 MHz PCI operating frequency is selected at reset via the pullup/pulldown resistor on the PCI66 pin: 0 – PCI operates at 66 MHz (default). 1 – PCI operates at 33 MHz. The -500 speed device supports PCI at 33 MHz only. For proper -500 device operation when the PCI is enabled (PCI_EN = 1), this pin must be pulled up with a 1-kΩ resistor at device reset. Note: If the PCI peripheral is disabled (PCI_EN pin = 0), this pin must not be pulled up. |
| HD5/AD5 | Y1 | HPI peripheral bus width (HPI_WIDTH) 0 – HPI operates as an HPI16. (HPI bus is 16 bits wide. HD[15:0] pins are used and the remaining HD[31:16] pins are reserved pins in the Hi-Z state.) 1 – HPI operates as an HPI32. (HPI bus is 32 bits wide. All HD[31:0] pins are used for host-port operations.) (Also see the PCI_EN; TOUT0/MAC_EN functional description in this table) |
| PCI_EN; TOUT0/MAC_EN | [E2; C5] | Peripheral Selection 00 – HPI (default mode) [HPI32, if HD5 = 1; HPI16 if HD5 = 0 01 – EMAC and MDIO; HPI16, if HD5 = 0; HPI disabled, if HD5 = 1 10 – PCI 11 – Reserved |

2.3 Peripheral Selection After Device Reset

McBSP1, McBSP0, and I2C0

The C6412 device has designated registers for peripheral configuration (PERCFG), device status (DEVSTAT), and JTAG identification (JTAGID). These registers are part of the Device Configuration module and are mapped to a 4K block memory starting at 0x01B3F000. The CPU accesses these registers via the CFGBUS.

The peripheral configuration register (PERCFG), allows the user to control the peripheral selection of the McBSP0, McBSP1, and I2C0 peripherals. For more detailed information on the PERCFG register control bits, see Figure 2–1 and Table 2–4.

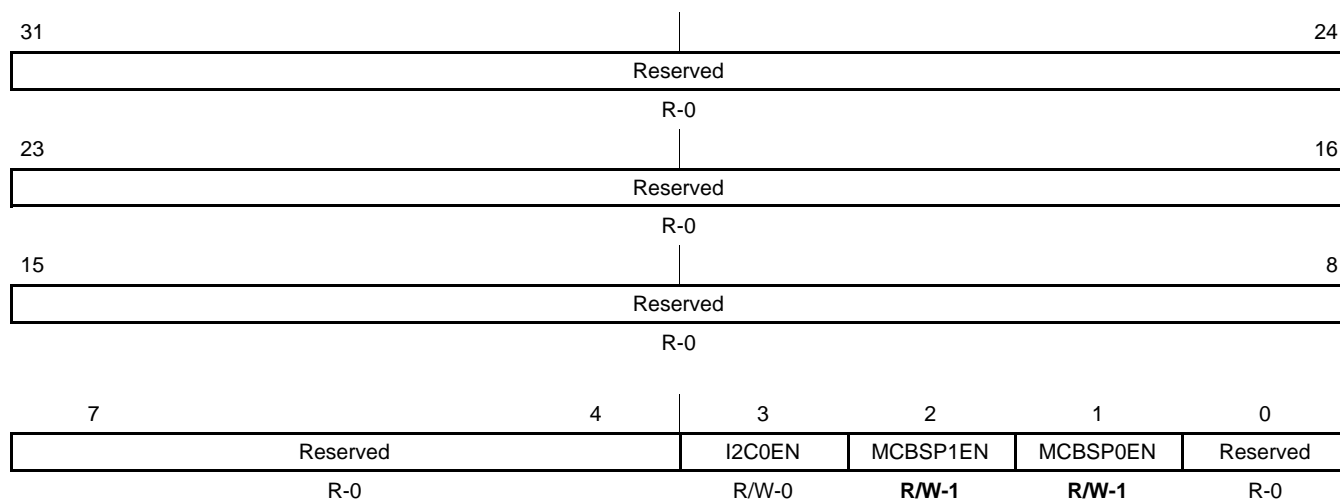

Legend: R = Read only; R/W = Read/Write; -n = value after reset

Figure 2–1. Peripheral Configuration Register (PERCFG) [Address Location: 0x01B3F000 – 0x01B3F003]

Table 2–4. Peripheral Configuration (PERCFG) Register Selection Bit Descriptions

| BIT | NAME | DESCRIPTION |
|------|----------|---|
| 31:4 | Reserved | Reserved. Read-only, writes have no effect. |
| 3 | I2C0EN | Inter-integrated circuit 0 (I2C0) enable bit. Selects whether I2C0 peripheral is enabled or disabled (default). 0 = I2C0 is disabled, and the module is powered down (default). 1 = I2C0 is enabled. |
| 2 | MCBSP1EN | McBSP1 enable bit. 0 = Reserved. Do not use. 1 = McBSP1 is enabled (default). |
| 1 | MCBSP0EN | McBSP0 enable bit. 0 = Reserved. Do not use. 1 = McBSP0 is enabled (default). |
| 0 | Reserved | Reserved. Read-only, writes have no effect. |

2.4 Peripheral Configuration Lock

By default, the I2C peripheral is disabled on power up. In order to use this peripheral on the C6412 device, the peripheral must first be enabled in the Peripheral Configuration register (PERCFG). **Software muxed pins should not be programmed to switch functionalities during run-time. Care should also be taken to ensure that no accesses are being performed before disabling the peripherals.** To help minimize power consumption in the C6412 device, unused peripherals may be disabled.

Figure 2–2 shows the flow needed to enable (or disable) a given peripheral on the C6412 device.

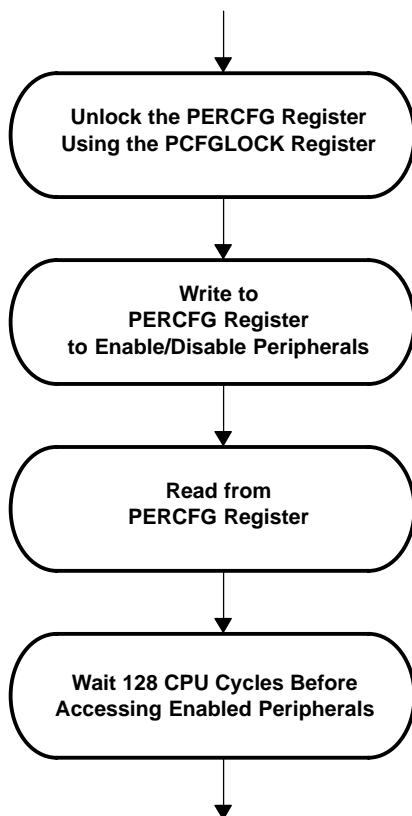
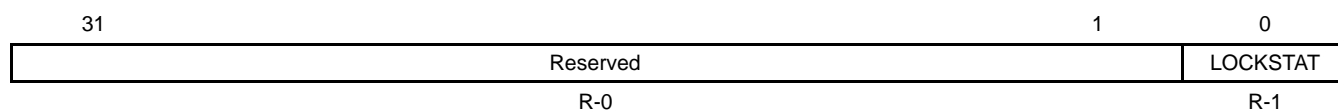
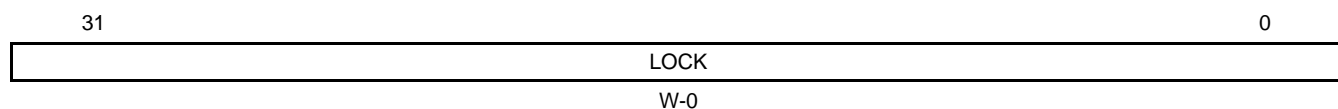

Figure 2–2. Peripheral Enable/Disable Flow Diagram

A 32-bit key (value = 0x10C0010C) must be written to the Peripheral Configuration Lock register (PCFGLOCK) in order to unlock access to the PERCFG register. Reading the PCFGLOCK register determines whether the PERCFG register is currently locked (LOCKSTAT bit = 1) or unlocked (LOCKSTAT bit = 0), see Figure 2–3. A peripheral can only be enabled when the PERCFG register is “unlocked” (LOCKSTAT bit = 0).

Read Accesses**Write Accesses**

Legend: R = Read only; R/W = Read/Write; -n = value after reset

Figure 2–3. PCFGLOCK Register Diagram [Address Location: 0x01B3 F018] – Read/Write Accesses

Table 2–5. PCFGLOCK Register Selection Bit Descriptions – Read Accesses

| BIT | NAME | DESCRIPTION |
|------|----------|--|
| 31:1 | Reserved | Reserved. Read-only, writes have no effect. |
| 0 | LOCKSTAT | Lock status bit. Determines whether the PERCFG register is locked or unlocked. 0 = Unlocked, read accesses to the PERCFG register allowed. 1 = Locked, write accesses to the PERCFG register do <i>not</i> modify the register state [default]. Reads are unaffected by Lock Status. |

Table 2–6. PCFGLOCK Register Selection Bit Descriptions – Write Accesses

| BIT | NAME | DESCRIPTION |
|------|------|--|
| 31:0 | LOCK | Lock bits. 0x10C0010C = Unlocks PERCFG register accesses. |

Any write to the PERCFG register will automatically relock the register. In order to avoid the unnecessary overhead of multiple unlock/enable sequences, all peripherals should be enabled with a single write to the PERCFG register with the necessary enable bits set.

Prior to waiting 128 CPU cycles, the PERCFG register should be read. There is no direct correlation between the CPU issuing a write to the PERCFG register and the write actually occurring. Reading the PERCFG register after the write is issued forces the CPU to wait for the write to the PERCFG register to occur.

Once a peripheral is enabled, the DSP (or other peripherals such as the HPI) must wait a minimum of 128 CPU cycles before accessing the enabled peripheral. The user *must* ensure that no accesses are performed to a peripheral while it is disabled.

2.5 Device Status Register Description

The device status register depicts the status of the device peripheral selection. For the actual register bit names and their associated bit field descriptions, see Figure 2–4 and Table 2–7.

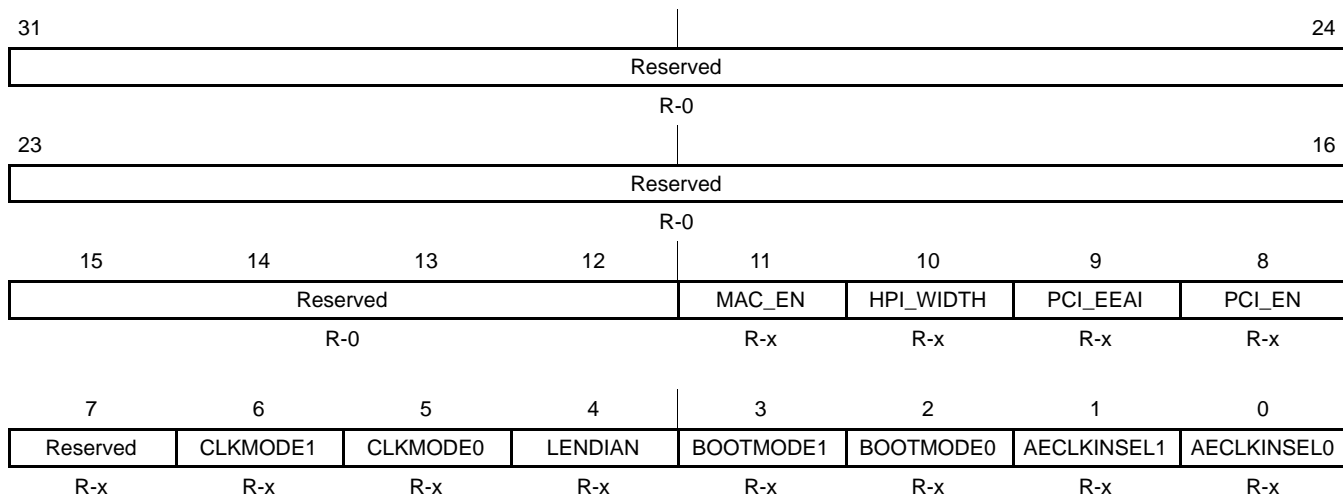

Legend: R = Read only; R/W = Read/Write; -n = value after reset

Figure 2–4. Device Status Register (DEVSTAT) Description – 0x01B3 F004

Table 2–7. Device Status (DEVSTAT) Register Selection Bit Descriptions

| BIT | NAME | DESCRIPTION |
|-------|-----------|--|
| 31:12 | Reserved | Reserved. Read-only, writes have no effect. |
| 11 | MAC_EN | EMAC enable bit. Shows the status of whether EMAC peripheral is enabled or disabled (default). 0 = EMAC is disabled, and the module is powered down (default). 1 = EMAC is enabled. This bit has no effect if the PCI peripheral is enabled (PCI_EN = 1). |
| 10 | HPI_WIDTH | HPI bus width control bit. Shows the status of whether the HPI bus operates in 32-bit mode or in 16-bit mode (default). 0 = HPI operates in 16-bit mode. (default). 1 = HPI operates in 32-bit mode. |
| 9 | PCI_EEAI | PCI EEPROM auto-initialization bit (PCI auto-initialization via external EEPROM). Shows the status of whether the PCI module initializes internal registers via external EEPROM or if the internal PCI default values are used instead (default). 0 = PCI auto-initialization through EEPROM is disabled; the PCI peripheral uses the specified PCI default values (default). 1 = PCI auto-initialization through EEPROM is enabled; the PCI peripheral is configured through EEPROM provided the PCI peripheral pin is enabled (PCI_EN = 1). |
| 8 | PCI_EN | PCI enable bit. Shows the status of whether the PCI peripheral is enabled or disabled (default). 0 = PCI disabled. (default). 1 = PCI enabled. Global select for the PCI vs. HPI/EMAC/MDIO/GPIO peripherals. |
| 7 | Reserved | Reserved. Read-only, writes have no effect. |

Table 2–7. Device Status (DEVSTAT) Register Selection Bit Descriptions (Continued)

| BIT | NAME | DESCRIPTION |
|-----|-------------|--|
| 6 | CLKMODE1 | Clock mode select bits Shows the status of whether the CPU clock frequency equals the input clock frequency X1 (Bypass), x6, or x12. Clock mode select for CPU clock frequency (CLKMODE[1:0]) 00 – Bypass (x1) (default mode) 01 – x6 10 – x12 11 – Reserved For more details on the CLKMODE pins and the PLL multiply factors, see the Clock PLL section of this data sheet. |
| 5 | CLKMODE0 | |
| 4 | LENDIAN | Device Endian mode (LEND) Shows the status of whether the system is operating in Big Endian mode or Little Endian mode (default). 0 – System is operating in Big Endian mode 1 – System is operating in Little Endian mode (default) |
| 3 | BOOTMODE1 | Bootmode configuration bits Shows the status of what device bootmode configuration is operational. Bootmode [1:0] 00 – No boot (default mode) 01 – HPI/PCI boot (based on PCI_EN pin) 10 – Reserved 11 – EMIFA 8-bit ROM boot |
| 2 | BOOTMODE0 | |
| 1 | AECLKINSEL1 | EMIFA input clock select Shows the status of what clock mode is enabled or disabled for the EMIF. Clock mode select for EMIFA (AECLKIN_SEL[1:0]) 00 – AECLKIN (default mode) 01 – CPU/4 Clock Rate 10 – CPU/6 Clock Rate 11 – Reserved |
| 0 | AECLKINSEL0 | |

2.6 JTAG ID Register Description

The JTAG ID register is a read-only register that identifies to the customer the JTAG/Device ID. For the C6412 device, the JTAG ID register resides at address location 0x01B3 F008. The register hex value for the C6412 device is: 0x0007 902F. For the actual register bit names and their associated bit field descriptions, see Figure 2–5 and Table 2–8.

| 31–28 | 27–12 | 11–1 | 0 |
|-----------------|-----------------------|-----------------------|-----|
| VARIANT (4-Bit) | PART NUMBER (16-Bit) | MANUFACTURER (11-Bit) | LSB |
| R-0000 | R-0000 0000 0111 1001 | R-0000 0010 111 | R-1 |

Legend: R = Read only; -n = value after reset

Figure 2–5. JTAG ID Register Description – TMS320C6412 Register Value – 0x0007 902F**Table 2–8. JTAG ID Register Selection Bit Descriptions**

| BIT | NAME | DESCRIPTION |
|-------|--------------|---|
| 31:28 | VARIANT | Variant (4-Bit) value. C6412 value: 0000. |
| 27:12 | PART NUMBER | Part Number (16-Bit) value. C6412 value: 0000 0000 0111 1001. |
| 11–1 | MANUFACTURER | Manufacturer (11-Bit) value. C6412 value: 0000 0010 111. |
| 0 | LSB | LSB. This bit is read as a “1” for C6412. |

2.7 Multiplexed Pins

Multiplexed pins are pins that are shared by more than one peripheral and are internally multiplexed. Some of these pins are configured by software, and the others are configured by external pullup/pulldown resistors only at reset. Those muxed pins that are configured by software should **not** be programmed to switch functionalities during run-time. Those muxed pins that are configured by external pullup/pulldown resistors are mutually exclusive; only one peripheral has primary control of the function of these pins after reset. Table 2–9 identifies the multiplexed pins on the C6412 device; shows the default (primary) function and the default settings after reset; and describes the pins, registers, etc. necessary to configure specific multiplexed functions.

2.8 Debugging Considerations

It is recommended that external connections be provided to device configuration pins, including TOUT1/LENDIAN, AEA[22:19], GP0[3]/PCIEEAI, GP0[8]/PCI66, HD5/AD5, PCI_EN, and TOUT0/MAC_EN. Although internal pullup/pulldown resistors exist on these pins, providing external connectivity adds convenience to the user in debugging and flexibility in switching operating modes.

Internal pullup/pulldown resistors also exist on the non-configuration pins on the AEA bus (AEA[18:0]). Do **not** oppose the internal pullup/pulldown resistors on these non-configuration pins with external pullup/pulldown resistors. If an external controller provides signals to these non-configuration pins, these signals must be driven to the default state of the pins at reset, or not be driven at all.

For the internal pullup/pulldown resistors for all device pins, see the terminal functions table.

Table 2–9. C6412 Device Multiplexed Pins†

| MULTIPLEXED PINS NAME | NO. | DEFAULT FUNCTION | DEFAULT SETTING | DESCRIPTION |
|--------------------------|-----|---------------------|--|--|
| CLKOUT4/GP0[1] | D6 | CLKOUT4 | GP1EN = 0 (disabled) | These pins are software-configurable. To use these pins as GPIO pins, the GPxEN bits in the GPIO Enable Register and the GPxDIR bits in the GPIO Direction Register must be properly configured. GPxEN = 1: GPx pin enabled GPxDIR = 0: GPx pin is an input GPxDIR = 1: GPx pin is an output |
| CLKOUT6/GP0[2] | C6 | CLKOUT6 | GP2EN = 0 (disabled) | |
| GP0[3]/PCIEEAI | L5 | PCIEEAI | GP3EN = 0 (disabled) | To use the PCI auto-initialization EEPROM (PCIEEAI) the PCI needs to be enabled (PCI_EN = 1): 0 – PCI auto-init through EEPROM disabled (default). 1 – PCI auto-init through EEPROM is enabled. To use GP0[3] as a GPIO pin, the PCI needs to be disabled (PCI_EN = 0), the GP3EN bits in the GPIO Enable Register and the GP3DIR bits in the GPIO Direction Register must be properly configured. GP3EN = 1: GP3 pin enabled GP3DIR = 0: GP3 pin is an input GP3DIR = 1: GP3 pin is an output |
| GP0[8]/PCI66 | AD1 | PCI66 | GP8EN = 0 (disabled) MAC_EN = 0 (disabled) | To use GP0[8] as a GPIO pin, the PCI needs to be disabled (PCI_EN = 0), the GPxEN bits in the GPIO Enable Register and the GPxDIR bits in the GPIO Direction Register must be properly configured. GP8EN = 1: GP8 pin enabled GP8DIR = 0: GP8 pin is an input GP8DIR = 1: GP8 pin is an output To use the PCI66 pin function, which changes the PCI operating frequency selection, the PCI needs to be enabled (PCI_EN = 1): 0 – PCI operates at 66 MHz (default). 1 – PCI operates at 33 MHz. The -500 device supports PCI at 33 MHz only. For proper -500 device operation when the PCI peripheral is enabled (PCI_EN = 1), this pin must be pulled up with a 1-kΩ resistor at device reset. If the PCI peripheral is disabled (PCI_EN pin = 0), this pin must not be pulled up. |
| GP0[9]/PIDSEL | K3 | None | GPxEN = 0 (disabled) PCI_EN = 0 (disabled)† | To use GP0[15:9] as GPIO pins, the PCI needs to be disabled (PCI_EN = 0), the GPxEN bits in the GPIO Enable Register and the GPxDIR bits in the GPIO Direction Register must be properly configured. GPxEN = 1: GPx pin enabled GPxDIR = 0: GPx pin is an input GPxDIR = 1: GPx pin is an output |
| GP0[10]/PCBE3 | J2 | | | |
| GP0[11]/PREQ | F1 | | | |
| GP0[12]/PGNT | H4 | | | |
| GP0[13]/PINTA | G4 | | | |
| GP0[14]/PCLK | C1 | | | |
| GP0[15]/PRST | G3 | | | |

† All other standalone PCI pins are tied-off internally (pins in Hi-Z) when the peripheral is disabled [PCI_EN = 0].

‡ For the HD[31:0]/AD[31:0] multiplexed pins pin numbers, see the *Terminal Functions* table.

Table 2–9. C6412 Device Multiplexed Pins† (Continued)

| MULTIPLEXED PINS NAME | NO. | DEFAULT FUNCTION | DEFAULT SETTING | DESCRIPTION |
|-------------------------|-----|--------------------|--|--|
| XSP_CLK/MDCLK | R5 | None | PCI_EN = 0 (disabled)† MAC_EN = 0 (disabled)† | By default, no functions enabled upon reset (PCI is disabled). To enable the PCI peripheral, an external pullup resistor (1 kΩ) must be provided on the PCI_EN pin (setting PCI_EN = 1 at reset). To enable the MDIO peripheral (which also enables the EMAC peripheral), an external pullup resistor (1 kΩ) must be provided on the MAC_EN pin (setting MAC_EN = 1 at reset). |
| XSP_DO/MDIO | P5 | | | |
| HAS/PPAR | P3 | HAS | PCI_EN = 0 (disabled)† | By default, HPI is enabled upon reset (PCI is disabled). To enable the PCI peripheral, an external pullup resistor (1 kΩ) must be provided on the PCI_EN pin (setting PCI_EN = 1 at reset). |
| HCNTL1/PDEVSEL | P1 | HCNTL1 | | |
| HCNTL0/PSTOP | R3 | HCNTL0 | | |
| HDS1/PSERR | R2 | HDS1 | | |
| HDS2/PCBE1 | T2 | HDS2 | | |
| HR/W/PCBE2 | M1 | HR/W | | |
| HHWIL/PTRDY | N3 | HHWIL (HPI16 only) | | |
| HINT/PFRAME | N4 | HINT | | |
| HCS/PPERR | R1 | HCS | | |
| HRDY/PIRDY | N1 | HRDY | | |
| HD[23,15:0]/AD[23,15:0] | ‡ | HD[23, 15:0] | PCI_EN = 0 (disabled)† | By default, HPI is enabled upon reset (PCI is disabled). To enable the PCI peripheral, an external pullup resistor (1 kΩ) must be provided on the PCI_EN pin (setting PCI_EN = 1 at reset). |
| HD31/AD31/MRCLK | G1 | HD31 | PCI_EN = 0 (disabled)† MAC_EN = 0 (disabled)† | By default, HPI is enabled upon reset (PCI is disabled). To enable the PCI peripheral, an external pullup resistor (1 kΩ) must be provided on the PCI_EN pin (setting PCI_EN = 1 at reset). To enable the EMAC peripheral, an external pullup resistor (1 kΩ) must be provided on the MAC_EN pin (setting MAC_EN = 1 at reset). |
| HD30/AD30/MCRS | H3 | HD30 | | |
| HD29/AD29/MRXER | G2 | HD29 | | |
| HD28/AD28/MRXDV | J4 | HD28 | | |
| HD27/AD27/MRXD3 | H2 | HD27 | | |
| HD26/AD26/MRXD2 | J3 | HD26 | | |
| HD25/AD25/MRXD1 | J1 | HD25 | | |
| HD24/AD24/MRXD0 | K4 | HD24 | | |
| HD22/AD22/MTCLK | L4 | HD22 | | |
| HD21/AD21/MCOL | K2 | HD21 | | |
| HD20/AD20/MTXEN | L3 | HD20 | | |
| HD19/AD19/MTXD3 | L2 | HD19 | | |
| HD18/AD18/MTXD2 | M4 | HD18 | | |
| HD17/AD17/MTXD1 | M2 | HD17 | | |
| HD16/AD16/MTXD0 | M3 | HD16 | | |

† All other standalone PCI pins are tied-off internally (pins in Hi-Z) when the peripheral is disabled [PCI_EN = 0].

‡ For the HD[31:0]/AD[31:0] multiplexed pins pin numbers, see the *Terminal Functions* table.

2.9 Configuration Examples

Figure 2–6 illustrates an example of peripheral selections that are configurable on the C6412 device.

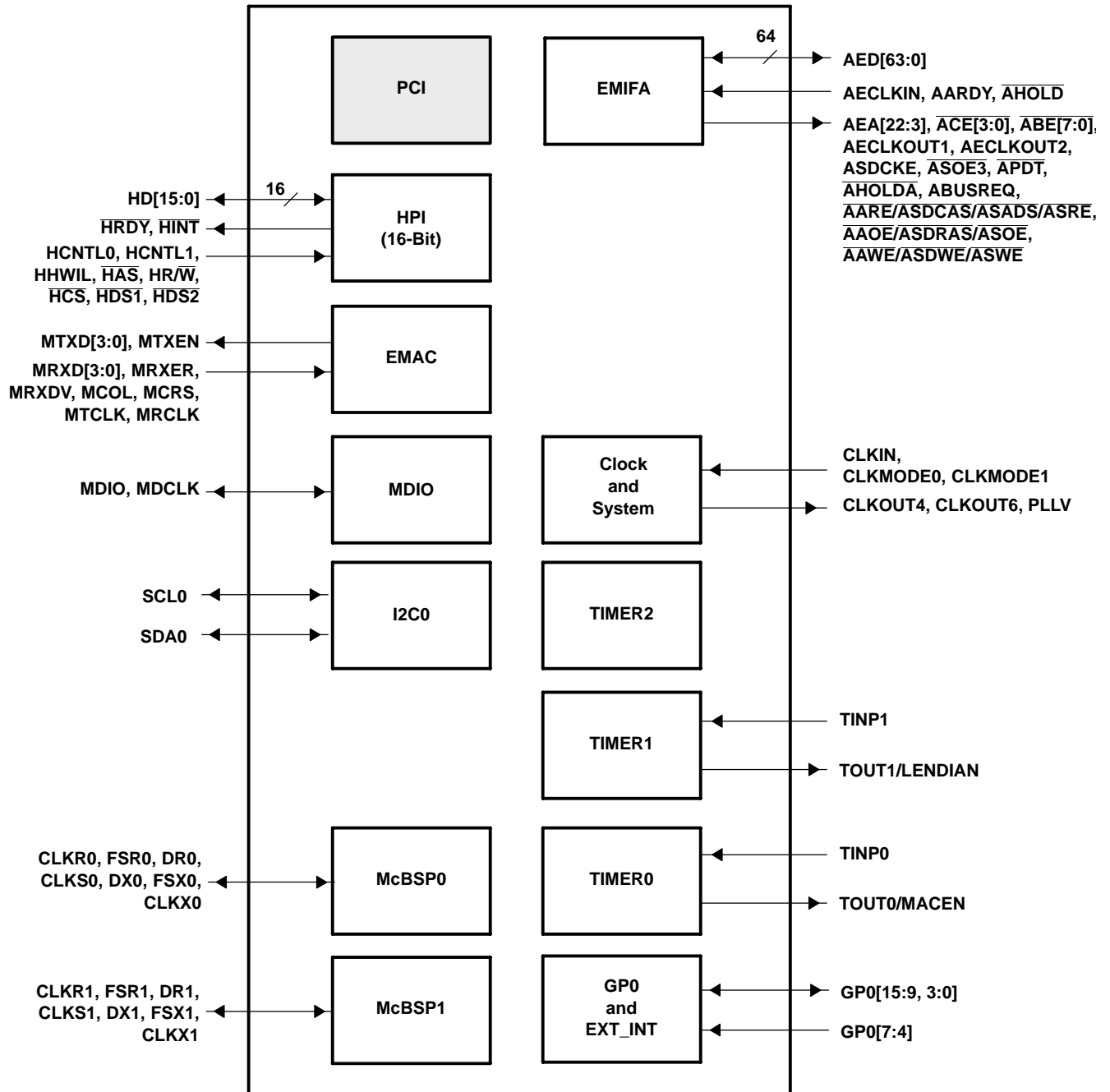

□ Shading denotes a peripheral module not available for this configuration.

PERCFG Register Value: 0x0000 000D
 External Pins: PCI_EN = 0 GP0[3]/PCIEEA1 = 0 HD5 = 0 TOUT0/MAC_EN = 1

**Figure 2–6. Configuration Example
 (2 McBSPs + EMAC + MDIO + I2C0 + EMIF + HPI + 3 Timers)**

2.10 Terminal Functions

The terminal functions table (Table 2–10) identifies the external signal names, the associated pin (ball) numbers along with the mechanical package designator, the pin type (I, O/Z, or I/O/Z), whether the pin has any internal pullup/pulldown resistors and a functional pin description. For more detailed information on device configuration, peripheral selection, multiplexed/shared pins, and debugging considerations, see the Device Configurations section of this data sheet.

Table 2–10. Terminal Functions

| SIGNAL NAME | GDK/ GNZ | TYPE† | IPD/ IPU‡ | DESCRIPTION |
|--------------------------------|----------|-------|-----------|--|
| CLOCK/PLL CONFIGURATION | | | | |
| CLKIN | AC2 | I | | Clock Input. This clock is the input to the on-chip PLL. |
| CLKOUT4/GP0[1]§ | D6 | I/O/Z | IPU | Clock output at 1/4 of the device speed (O/Z) [default] or this pin can be programmed as a GP0 1 pin (I/O/Z). |
| CLKOUT6/GP0[2]§ | C6 | I/O/Z | IPU | Clock output at 1/6 of the device speed (O/Z) [default] or this pin can be programmed as a GP0 2 pin (I/O/Z). |
| CLKMODE1 | AE4 | I | IPD | Clock mode select <ul style="list-style-type: none"> Selects whether the CPU clock frequency = input clock frequency x1 (Bypass), x6, or x12. For more details on the CLKMODE pins and the PLL multiply factors, see the Clock PLL section of this data sheet. |
| CLKMODE0 | AA2 | I | IPD | |
| PLLV¶ | V6 | A# | | PLL voltage supply |
| JTAG EMULATION | | | | |
| TMS | E15 | I | IPU | JTAG test-port mode select |
| TDO | B18 | O/Z | IPU | JTAG test-port data out |
| TDI | A18 | I | IPU | JTAG test-port data in |
| TCK | A16 | I | IPU | JTAG test-port clock |
| TRST | D14 | I | IPD | JTAG test-port reset. For IEEE 1149.1 JTAG compatibility, see the IEEE 1149.1 JTAG compatibility statement portion of this data sheet. |
| EMU11 | D17 | I/O/Z | IPU | Emulation clock 1. Reserved for future use, leave unconnected. |
| EMU10 | C17 | I/O/Z | IPU | Emulation clock 0. Reserved for future use, leave unconnected. |
| EMU9 | B17 | I/O/Z | IPU | Emulation pin 9. Reserved for future use, leave unconnected. |
| EMU8 | D16 | I/O/Z | IPU | Emulation pin 8. Reserved for future use, leave unconnected. |
| EMU7 | A17 | I/O/Z | IPU | Emulation pin 7. Reserved for future use, leave unconnected. |
| EMU6 | C16 | I/O/Z | IPU | Emulation pin 6. Reserved for future use, leave unconnected. |
| EMU5 | B16 | I/O/Z | IPU | Emulation pin 5. Reserved for future use, leave unconnected. |
| EMU4 | D15 | I/O/Z | IPU | Emulation pin 4. Reserved for future use, leave unconnected. |
| EMU3 | C15 | I/O/Z | IPU | Emulation pin 3. Reserved for future use, leave unconnected. |
| EMU2 | B15 | I/O/Z | IPU | Emulation pin 2. Reserved for future use, leave unconnected. |
| EMU1 | C14 | I/O/Z | IPU | Emulation pin 1 |
| EMU0 | A15 | I/O/Z | IPU | Emulation pin 0 |

† I = Input, O = Output, Z = High impedance, S = Supply voltage, GND = Ground

‡ IPD = Internal pulldown, IPU = Internal pullup. (These IPD/IPU signal pins feature a 30-kΩ IPD or IPU resistor. To pull up a signal to the opposite supply rail, a 1-kΩ resistor should be used.)

§ These pins are multiplexed pins. For more details, see the Device Configurations section of this data manual.

¶ PLLV is not part of external voltage supply. See the Clock PLL section for information on how to connect this pin.

A = Analog signal (PLL Filter)

|| The EMU0 and EMU1 pins are internally pulled up with 30-kΩ resistors; therefore, for emulation and normal operation, no external pullup/pulldown resistors are necessary. However, for boundary scan operation, pull down the EMU1 and EMU0 pins with a dedicated 1-kΩ resistor.

Table 2–10. Terminal Functions (Continued)

| SIGNAL NAME | GDK/GNZ | TYPE† | IPD/IPU‡ | DESCRIPTION |
|--|---------|-------|--|--|
| RESETS, INTERRUPTS, AND GENERAL-PURPOSE INPUT/OUTPUTS | | | | |
| RESET | P4 | I | | Device reset |
| NMI | B4 | I | IPD | Nonmaskable interrupt, edge-driven (rising edge) Note: Any noise on the NMI pin may trigger an NMI interrupt; therefore, if the NMI pin is not used, it is recommended that the NMI pin be grounded versus relying on the IPD. |
| GP0[7]/EXT_INT7 | E1 | I/O/Z | IPU | General-purpose input/output (GPIO) pins (I/O/Z) or external interrupts (input only). The default after reset setting is GPIO enabled as input-only. • When these pins function as External Interrupts [by selecting the corresponding interrupt enable register bit (IER.[7:4])], they are edge-driven and the polarity can be independently selected via the External Interrupt Polarity Register bits (EXTPOL.[3:0]). |
| GP0[6]/EXT_INT6 | F2 | I/O/Z | IPU | |
| GP0[5]/EXT_INT5 | F3 | I/O/Z | IPU | |
| GP0[4]/EXT_INT4 | F4 | I/O/Z | IPU | |
| GP0[15]/ $\overline{\text{PRST}}^{\S}$ | G3 | I/O/Z | | General-purpose input/output (GP0) 15 pin (I/O/Z) or PCI reset (I). No function at default. |
| GP0[14]/PCLK § | C1 | | GP0 14 pin (I/O/Z) or PCI clock (I). No function at default. | |
| GP0[13]/PINTA § | G4 | | GP0 13 pin (I/O/Z) or PCI interrupt A (O/Z). No function at default. | |
| GP0[12]/PGNT § | H4 | | GP0 12 pin (I/O/Z) or PCI bus grant (I). No function at default. | |
| GP0[11]/ $\overline{\text{PREQ}}^{\S}$ | F1 | | GP0 11 pin (I/O/Z) or PCI bus request (O/Z). No function at default. | |
| GP0[10]/PCBE3 § | J2 | | GP0 10 pin (I/O/Z) or PCI command/byte enable 3 (I/O/Z). No function at default. | |
| GP0[9]/PIDSEL § | K3 | | GP0 9 pin (I/O/Z) or PCI initialization device select (I). No function at default. | |
| GP0[3]/PCIEEAI | L5 | | IPD | GP0 3 pin (I/O/Z) and PCI EEPROM Auto-Initialization (EEAI). If the PCI peripheral is disabled (PCI_EN pin = 0), this pin must not be pulled up. 0 – PCI auto-initialization through EEPROM is disabled (default). 1 – PCI auto-initialization through EEPROM is enabled. |
| GP0[0] | M5 | I/O/Z | IPD | GP0 0 pin (I/O/Z) [default]. The general-purpose 0 pin (GP0[0]) (I/O/Z) can be programmed as GPIO 0 (input only) [default] or as GP0[0] (output only) pin or output as a general-purpose interrupt (GP0INT) signal (output only). Note: This pin must remain low during device reset. For more details, see the Device Configurations section of this data manual. |
| GP0[8]/PCI66 § | AD1 | I/O/Z | IPD | This pin can be programmed as a GP0 8 pin (I/O/Z) or PCI frequency selection (PCI66). If the PCI peripheral is enabled (PCI_EN pin = 1), then: 0 – PCI operates at 66 MHz (default). 1 – PCI operates at 33 MHz. The -500 device supports PCI at 33 MHz only. For proper -500 device operation when the PCI peripheral is enabled (PCI_EN = 1), this pin must be pulled up with a 1-k Ω resistor at device reset. If the PCI peripheral is disabled (PCI_EN pin = 0), this pin must not be pulled up. |
| CLKOUT6/GP0[2] § | C6 | I/O/Z | IPU | Clock output at 1/6 of the device speed (O/Z) [default] or this pin can be programmed as a GP0 2 pin (I/O/Z). |
| CLKOUT4/GP0[1] § | D6 | I/O/Z | IPU | Clock output at 1/4 of the device speed (O/Z) [default] or this pin can be programmed as a GP0 1 pin (I/O/Z). |

† I = Input, O = Output, Z = High impedance, S = Supply voltage, GND = Ground

‡ IPD = Internal pulldown, IPU = Internal pullup. (These IPD/IPU signal pins feature a 30-k Ω IPD or IPU resistor. To pull up a signal to the opposite supply rail, a 1-k Ω resistor should be used.)

§ These pins are multiplexed pins. For more details, see the Device Configurations section of this data manual.

¶ PLLV is not part of external voltage supply. See the Clock PLL section for information on how to connect this pin.

A = Analog signal (PLL Filter)

|| The EMU0 and EMU1 pins are internally pulled up with 30-k Ω resistors; therefore, for emulation and normal operation, no external pullup/pulldown resistors are necessary. However, for boundary scan operation, pull down the EMU1 and EMU0 pins with a dedicated 1-k Ω resistor.

Table 2–10. Terminal Functions (Continued)

| SIGNAL NAME | GDK/ GNZ | TYPE† | IPD/ IPU‡ | DESCRIPTION |
|---|-------------|-------|--------------|--|
| HOST-PORT INTERFACE (HPI) OR PERIPHERAL COMPONENT INTERCONNECT (PCI) OR EMAC | | | | |
| PCI_EN | E2 | I | IPD | PCI enable pin. This pin and the MAC_EN pin control the selection (enable/disable) of the HPI, EMAC, MDIO, and GP0[15:8], or PCI peripherals. The pins work in conjunction to enable/disable these peripherals (for more details, see the Device Configurations section of this data sheet). |
| HINT/PFRAME§ | N4 | I/O/Z | | Host interrupt from DSP to host (O) [default] or PCI frame (I/O/Z) |
| HCNTL1/ PDEVSEL§ | P1 | I/O/Z | | Host control – selects between control, address, or data registers (I) [default] or PCI device select (I/O/Z). |
| HCNTL0/ PSTOP§ | R3 | I/O/Z | | Host control – selects between control, address, or data registers (I) [default] or PCI stop (I/O/Z) |
| HHWIL/PTRDY§ | N3 | I/O/Z | | Host half-word select – first or second half-word (not necessarily high or low order) [For HPI16 bus width selection only] (I) [default] or PCI target ready (I/O/Z) |
| HRW/PCBE2§ | M1 | I/O/Z | | Host read or write select (I) [default] or PCI command/byte enable 2 (I/O/Z) |
| HAS/PPAR§ | P3 | I/O/Z | | Host address strobe (I) [default] or PCI parity (I/O/Z) |
| HCS/PPER§ | R1 | I/O/Z | | Host chip select (I) [default] or PCI parity error (I/O/Z) |
| HDS1/PSERR§ | R2 | I/O/Z | | Host data strobe 1 (I) [default] or PCI system error (I/O/Z) |
| HDS2/PCBE1§ | T2 | I/O/Z | | Host data strobe 2 (I) [default] or PCI command/byte enable 1 (I/O/Z) |
| HRDY/PIRDY§ | N1 | I/O/Z | | Host ready from DSP to host (O) [default] or PCI initiator ready (I/O/Z). |

† I = Input, O = Output, Z = High impedance, S = Supply voltage, GND = Ground

‡ IPD = Internal pulldown, IPU = Internal pullup. (These IPD/IPU signal pins feature a 30-k Ω IPD or IPU resistor. To pull up a signal to the opposite supply rail, a 1-k Ω resistor should be used.)

§ These pins are multiplexed pins. For more details, see the Device Configurations section of this data manual.

¶ PLLV is not part of external voltage supply. See the Clock PLL section for information on how to connect this pin.

A = Analog signal (PLL Filter)

|| The EMU0 and EMU1 pins are internally pulled up with 30-k Ω resistors; therefore, for emulation and normal operation, no external pullup/pulldown resistors are necessary. However, for boundary scan operation, pull down the EMU1 and EMU0 pins with a dedicated 1-k Ω resistor.

Table 2–10. Terminal Functions (Continued)

| SIGNAL NAME | GDK/ GNZ | TYPE† | IPD/ IPU‡ | DESCRIPTION |
|---|----------|-------|-----------|--|
| HOST-PORT INTERFACE (HPI) OR PERIPHERAL COMPONENT INTERCONNECT (PCI) OR EMAC (CONTINUED) | | | | |
| HD31/AD31/MRCLK§ | G1 | I/O/Z | | <p>Host-port data (I/O/Z) [default] or PCI data-address bus (I/O/Z) or EMAC transmit/receive or control pins</p> <p>As HPI data bus (PCI_EN pin = 0)</p> <ul style="list-style-type: none"> Used for transfer of data, address, and control Host-Port bus width user-configurable at device reset via a 10-kΩ resistor pullup/pulldown resistor on the HD5 pin: <p>HD5 pin = 0: HPI operates as an HPI16. (HPI bus is 16 bits wide. HD[15:0] pins are used and the remaining HD[31:16] pins are reserved pins in the high-impedance state.)</p> <p>HD5 pin = 1: HPI operates as an HPI32. (HPI bus is 32 bits wide. All HD[31:0] pins are used for host-port operations.)</p> <p>As PCI data-address bus (PCI_EN pin = 1)</p> <ul style="list-style-type: none"> Used for transfer of data and address <p>For superset devices like C6412, the HD31/AD31 through HD16/AD16 pins can also function as EMAC transmit/receive or control pins (when PCI_EN pin = 0; MAC_EN pin = 1). For more details on the EMAC pin functions, see the <i>Ethernet MAC (EMAC) peripheral</i> section of this table and for more details on how to configure the EMAC pin, see the device configuration section of this data sheet.</p> |
| HD30/AD30/MCRS§ | H3 | | | |
| HD29/AD29/MRXER§ | G2 | | | |
| HD28/AD28/MRXDV§ | J4 | | | |
| HD27/AD27/MRXD3§ | H2 | | | |
| HD26/AD26/MRXD2§ | J3 | | | |
| HD25/AD25/MRXD1§ | J1 | | | |
| HD24/AD24/MRXD0§ | K4 | | | |
| HD23/AD23§ | K1 | | | |
| HD22/AD22/MTCLK§ | L4 | | | |
| HD21/AD21/MCOL§ | K2 | | | |
| HD20/AD20/MTXEN§ | L3 | | | |
| HD19/AD19/MTXD3§ | L2 | | | |
| HD18/AD18/MTXD2§ | M4 | | | |
| HD17/AD17/MTXD1§ | M2 | | | |
| HD16/AD16/MTXD0§ | M3 | | | |
| HD15/AD15§ | T3 | | | |
| HD14/AD14§ | U1 | | | |
| HD13/AD13§ | U3 | | | |
| HD12/AD12§ | U2 | | | |
| HD11/AD11§ | U4 | | | |
| HD10/AD10§ | V1 | | | |
| HD9/AD9§ | V3 | | | |
| HD8/AD8§ | V2 | | | |
| HD7/AD7§ | W2 | | | |
| HD6/AD6§ | W4 | | | |
| HD5/AD5§ | Y1 | | | |
| HD4/AD4§ | W3 | | | |
| HD3/AD3§ | Y2 | | | |
| HD2/AD2§ | Y4 | | | |
| HD1/AD1§ | AA1 | | | |
| HD0/AD0§ | Y3 | | | |

† I = Input, O = Output, Z = High impedance, S = Supply voltage, GND = Ground

‡ IPD = Internal pulldown, IPU = Internal pullup. (These IPD/IPU signal pins feature a 30-k Ω IPD or IPU resistor. To pull up a signal to the opposite supply rail, a 1-k Ω resistor should be used.)

§ These pins are multiplexed pins. For more details, see the Device Configurations section of this data manual.

¶ PLLV is not part of external voltage supply. See the Clock PLL section for information on how to connect this pin.

A = Analog signal (PLL Filter)

|| The EMU0 and EMU1 pins are internally pulled up with 30-k Ω resistors; therefore, for emulation and normal operation, no external pullup/pulldown resistors are necessary. However, for boundary scan operation, pull down the EMU1 and EMU0 pins with a dedicated 1-k Ω resistor.

Table 2–10. Terminal Functions (Continued)

| SIGNAL NAME | GDK/GNZ | TYPE† | IPD/IPU‡ | DESCRIPTION |
|---|---------|-------|--|--|
| HOST-PORT INTERFACE (HPI) OR PERIPHERAL COMPONENT INTERCONNECT (PCI) OR EMAC (CONTINUED) | | | | |
| PCBE0 | V4 | I/O/Z | | PCI command/byte enable 0 (I/O/Z). When PCI is disabled (PCI_EN = 0), this pin is tied-off. |
| GP0[15]/PRST§ | G3 | I/O/Z | | General-purpose input/output (GP0) 15 pin (I/O/Z) or PCI reset (I). No function at default. |
| XSP_CS | T4 | O | IPD | PCI serial interface chip select (O). When PCI is disabled (PCI_EN = 0), this pin is tied-off. |
| XSP_CLK/MDCLK§ | R5 | I/O/Z | IPD | PCI serial interface clock (O) [default] or MDIO serial clock input/output (I/O/Z). |
| XSP_DI | R4 | I | IPU | PCI serial interface data in (I) [default]. In PCI mode, this pin is connected to the output data pin of the serial PROM. |
| XSP_DO/MDIO§ | P5 | I/O/Z | IPU | PCI serial interface data out (O) [default] or MDIO serial data input/output (I/O/Z). In PCI mode, this pin is connected to the input data pin of the serial PROM. |
| GP0[14]/PCLK§ | C1 | I/O/Z | | GP0 14 pin (I/O/Z) or PCI clock (I). No function at default. |
| GP0[13]/PINTA§ | G4 | | GP0 13 pin (I/O/Z) or PCI interrupt A (O/Z). No function at default. | |
| GP0[12]/PGNT§ | H4 | | GP0 12 pin (I/O/Z) or PCI bus grant (I). No function at default. | |
| GP0[11]/PREQ§ | F1 | | GP0 11 pin (I/O/Z) or PCI bus request (O/Z). No function at default. | |
| GP0[10]/PCBE3§ | J2 | | GP0 10 pin (I/O/Z) or PCI command/byte enable 3 (I/O/Z). No function at default. | |
| GP0[9]/PIDSEL§ | K3 | | GP0 9 pin (I/O/Z) or PCI initialization device select (I). No function at default. | |
| GP0[3]/PCIEEAI | L5 | I/O/Z | IPD | GP0 3 pin (I/O/Z) and PCI EEPROM Auto-Initialization (EEAI). If the PCI peripheral is disabled (PCI_EN pin = 0), this pin must not be pulled up. 0 – PCI auto-initialization through EEPROM is disabled (default). 1 – PCI auto-initialization through EEPROM is enabled. |
| GP0[8]/PCI66§ | AD1 | I/O/Z | IPD | This pin can be programmed as a GP0 8 pin (I/O/Z) or PCI frequency selection (PCI66). If the PCI peripheral is enabled (PCI_EN pin = 1), then: 0 – PCI operates at 66 MHz (default). 1 – PCI operates at 33 MHz. The -500 device supports PCI at 33 MHz only. For proper -500 device operation when the PCI peripheral is enabled (PCI_EN = 1), this pin must be pulled up with a 1-kΩ resistor at device reset. If the PCI peripheral is disabled (PCI_EN pin = 0), this pin must not be pulled up. |
| EMIFA (64-BIT) – CONTROL SIGNALS COMMON TO ALL TYPES OF MEMORY | | | | |
| ACE3 | L26 | O/Z | IPU | EMIFA memory space enables • Enabled by bits 28 through 31 of the word address • Only one pin is asserted during any external data access |
| ACE2 | K23 | O/Z | IPU | |
| ACE1 | K24 | O/Z | IPU | |
| ACE0 | K25 | O/Z | IPU | |

† I = Input, O = Output, Z = High impedance, S = Supply voltage, GND = Ground

‡ IPD = Internal pulldown, IPU = Internal pullup. (These IPD/IPU signal pins feature a 30-kΩ IPD or IPU resistor. To pull up a signal to the opposite supply rail, a 1-kΩ resistor should be used.)

§ These pins are multiplexed pins. For more details, see the Device Configurations section of this data manual.

¶ PLLV is not part of external voltage supply. See the Clock PLL section for information on how to connect this pin.

A = Analog signal (PLL Filter)

|| The EMU0 and EMU1 pins are internally pulled up with 30-kΩ resistors; therefore, for emulation and normal operation, no external pullup/pulldown resistors are necessary. However, for boundary scan operation, pull down the EMU1 and EMU0 pins with a dedicated 1-kΩ resistor.

Table 2–10. Terminal Functions (Continued)

| SIGNAL NAME | GDK/ GNZ | TYPE† | IPD/ IPU‡ | DESCRIPTION |
|---|----------|-------|-----------|---|
| EMIFA (64-BIT) – CONTROL SIGNALS COMMON TO ALL TYPES OF MEMORY (CONTINUED) | | | | |
| ABE7 | T22 | O/Z | IPU | EMIFA byte-enable control <ul style="list-style-type: none"> Decoded from the low-order address bits. The number of address bits or byte enables used depends on the width of external memory. Byte-write enables for most types of memory Can be directly connected to SDRAM read and write mask signal (SDQM) |
| ABE6 | T23 | O/Z | IPU | |
| ABE5 | R25 | O/Z | IPU | |
| ABE4 | R26 | O/Z | IPU | |
| ABE3 | M25 | O/Z | IPU | |
| ABE2 | M26 | O/Z | IPU | |
| ABE1 | L23 | O/Z | IPU | |
| ABE0 | L24 | O/Z | IPU | |
| APDT | M22 | O/Z | IPU | EMIFA peripheral data transfer, allows direct transfer between external peripherals |
| EMIFA (64-BIT) – BUS ARBITRATION* | | | | |
| AHOLDA | N22 | O | IPU | EMIFA hold-request-acknowledge to the host |
| AHOLD | W24 | I | IPU | EMIFA hold request from the host |
| ABUSREQ | P22 | O | IPU | EMIFA bus request output |
| EMIFA (64-BIT) – ASYNCHRONOUS/SYNCHRONOUS MEMORY CONTROL | | | | |
| AECLKIN | H25 | I | IPD | EMIFA external input clock. The EMIFA input clock (AECLKIN, CPU/4 clock, or CPU/6 clock) is selected at reset via the pullup/pulldown resistors on the AEA[20:19] pins. AECLKIN is the default for the EMIFA input clock. |
| AECLKOUT2 | J23 | O/Z | IPD | EMIFA output clock 2. Programmable to be EMIFA input clock (AECLKIN, CPU/4 clock, or CPU/6 clock) frequency divided-by-1, -2, or -4. |
| AECLKOUT1 | J26 | O/Z | IPD | EMIFA output clock 1 [at EMIFA input clock (AECLKIN, CPU/4 clock, or CPU/6 clock) frequency]. |
| AARE/ ASDCAS/ ASADS/ASRE | J25 | O/Z | IPU | EMIFA asynchronous memory read-enable/SDRAM column-address strobe/programmable synchronous interface-address strobe or read-enable <ul style="list-style-type: none"> For programmable synchronous interface, the RENEN field in the CE Space Secondary Control Register (CEXSEC) selects between ASADS and ASRE: If RENEN = 0, then the ASADS/ASRE signal functions as the ASADS signal. If RENEN = 1, then the ASADS/ASRE signal functions as the ASRE signal. |
| AAOE/ ASDRAS/ ASOE | J24 | O/Z | IPU | EMIFA asynchronous memory output-enable/SDRAM row-address strobe/programmable synchronous interface output-enable |
| AAWE/ ASDWE/ ASWE | K26 | O/Z | IPU | EMIFA asynchronous memory write-enable/SDRAM write-enable/programmable synchronous interface write-enable |
| ASDCKE | L25 | O/Z | IPU | EMIFA SDRAM clock-enable (used for self-refresh mode). [EMIFA module only.] <ul style="list-style-type: none"> If SDRAM is not in system, ASDCKE can be used as a general-purpose output. |
| ASOE3 | R22 | O/Z | IPU | EMIFA synchronous memory output-enable for ACE3 (for glueless FIFO interface) |
| AARDY | L22 | I | IPU | Asynchronous memory ready input |

† I = Input, O = Output, Z = High impedance, S = Supply voltage, GND = Ground

‡ IPD = Internal pulldown, IPU = Internal pullup. (These IPD/IPU signal pins feature a 30-kΩ IPD or IPU resistor. To pull up a signal to the opposite supply rail, a 1-kΩ resistor should be used.)

§ These pins are multiplexed pins. For more details, see the Device Configurations section of this data manual.

¶ PLLV is not part of external voltage supply. See the Clock PLL section for information on how to connect this pin.

A = Analog signal (PLL Filter)

|| The EMU0 and EMU1 pins are internally pulled up with 30-kΩ resistors; therefore, for emulation and normal operation, no external pullup/pulldown resistors are necessary. However, for boundary scan operation, pull down the EMU1 and EMU0 pins with a dedicated 1-kΩ resistor.

Table 2–10. Terminal Functions (Continued)

| SIGNAL NAME | GDK/ GNZ | TYPE† | IPD/ IPU‡ | DESCRIPTION |
|---------------------------------|----------|-------|-----------|--|
| EMIFA (64-BIT) – ADDRESS | | | | |
| AEA22 | U23 | O/Z | IPD | <p>EMIFA external address (doubleword address) Note: EMIFA address numbering for the C6412 device starts with AEA3 to maintain signal name compatibility with other C64x™ devices (e.g., C6414, C6415, and C6416) [see the 64-bit EMIF addressing scheme in the <i>TMS320C6000 DSP External Memory Interface (EMIF) Reference Guide</i> (literature number SPRU266)].</p> <ul style="list-style-type: none"> • Also controls initialization of DSP modes at reset (I) via pullup/pulldown resistors <ul style="list-style-type: none"> – Boot mode (AEA[22:21]): <ul style="list-style-type: none"> 00 – No boot (default mode) 01 – HPI/PCI boot (based on PCI_EN pin) 10 – Reserved 11 – EMIFA 8-bit ROM boot – EMIF clock select – AEA[20:19]: Clock mode select for EMIFA (AECLKIN_SEL[1:0]) <ul style="list-style-type: none"> 00 – AECLKIN (default mode) 01 – CPU/4 Clock Rate 10 – CPU/6 Clock Rate 11 – Reserved <p>For more details, see the Device Configurations section of this data sheet.</p> |
| AEA21 | V24 | | | |
| AEA20 | V25 | | | |
| AEA19 | V26 | | | |
| AEA18 | V23 | | | |
| AEA17 | U24 | | | |
| AEA16 | U25 | | | |
| AEA15 | U26 | | | |
| AEA14 | T24 | | | |
| AEA13 | T25 | | | |
| AEA12 | R23 | | | |
| AEA11 | R24 | | | |
| AEA10 | P23 | | | |
| AEA9 | P24 | | | |
| AEA8 | P26 | | | |
| AEA7 | N23 | | | |
| AEA6 | N24 | | | |
| AEA5 | N26 | | | |
| AEA4 | M23 | | | |
| AEA3 | M24 | | | |
| EMIFA (64-BIT) – DATA | | | | |
| AED63 | AF24 | I/O/Z | IPU | EMIFA external data |
| AED62 | AF23 | | | |
| AED61 | AE23 | | | |
| AED60 | AD23 | | | |
| AED59 | AD22 | | | |
| AED58 | AE22 | | | |
| AED57 | AD21 | | | |
| AED56 | AE21 | | | |
| AED55 | AC21 | | | |
| AED54 | AF21 | | | |
| AED53 | AD20 | | | |
| AED52 | AE20 | | | |
| AED51 | AC20 | | | |

† I = Input, O = Output, Z = High impedance, S = Supply voltage, GND = Ground

‡ IPD = Internal pulldown, IPU = Internal pullup. (These IPD/IPU signal pins feature a 30-k Ω IPD or IPU resistor. To pull up a signal to the opposite supply rail, a 1-k Ω resistor should be used.)

§ These pins are multiplexed pins. For more details, see the Device Configurations section of this data manual.

¶ PLLV is not part of external voltage supply. See the Clock PLL section for information on how to connect this pin.

A = Analog signal (PLL Filter)

|| The EMU0 and EMU1 pins are internally pulled up with 30-k Ω resistors; therefore, for emulation and normal operation, no external pullup/pulldown resistors are necessary. However, for boundary scan operation, pull down the EMU1 and EMU0 pins with a dedicated 1-k Ω resistor.

Table 2–10. Terminal Functions (Continued)

| SIGNAL NAME | GDK/ GNZ | TYPE† | IPD/ IPU‡ | DESCRIPTION |
|-----------------------------------|-------------|-------|--------------|---------------------|
| EMIFA (64-BIT) – DATA (CONTINUED) | | | | |
| AED50 | AF20 | I/O/Z | IPU | EMIFA external data |
| AED49 | AC19 | | | |
| AED48 | AD19 | | | |
| AED47 | W23 | | | |
| AED46 | Y26 | | | |
| AED45 | Y23 | | | |
| AED44 | Y25 | | | |
| AED43 | Y24 | | | |
| AED42 | AA26 | | | |
| AED41 | AA23 | | | |
| AED40 | AA25 | | | |
| AED39 | AA24 | | | |
| AED38 | AB23 | | | |
| AED37 | AB25 | | | |
| AED36 | AB24 | | | |
| AED35 | AC26 | | | |
| AED34 | AC25 | | | |
| AED33 | AD25 | | | |
| AED32 | AD26 | | | |
| AED31 | C26 | | | |
| AED30 | C25 | | | |
| AED29 | D26 | | | |
| AED28 | D25 | | | |
| AED27 | E24 | | | |
| AED26 | E25 | | | |
| AED25 | F24 | | | |
| AED24 | F25 | | | |
| AED23 | F23 | | | |
| AED22 | F26 | | | |
| AED21 | G24 | | | |
| AED20 | G25 | | | |
| AED19 | G23 | | | |
| AED18 | G26 | | | |
| AED17 | H23 | | | |

† I = Input, O = Output, Z = High impedance, S = Supply voltage, GND = Ground

‡ IPD = Internal pulldown, IPU = Internal pullup. (These IPD/IPU signal pins feature a 30-k Ω IPD or IPU resistor. To pull up a signal to the opposite supply rail, a 1-k Ω resistor should be used.)

§ These pins are multiplexed pins. For more details, see the Device Configurations section of this data manual.

¶ PLLV is not part of external voltage supply. See the Clock PLL section for information on how to connect this pin.

A = Analog signal (PLL Filter)

|| The EMU0 and EMU1 pins are internally pulled up with 30-k Ω resistors; therefore, for emulation and normal operation, no external pullup/pulldown resistors are necessary. However, for boundary scan operation, pull down the EMU1 and EMU0 pins with a dedicated 1-k Ω resistor.

Table 2–10. Terminal Functions (Continued)

| SIGNAL NAME | GDK/ GNZ | TYPE† | IPD/ IPU‡ | DESCRIPTION |
|--|-------------|-------|--------------|--|
| EMIFA (64-BIT) – DATA (CONTINUED) | | | | |
| AED16 | H24 | I/O/Z | IPU | EMIFA external data |
| AED15 | C19 | | | |
| AED14 | D19 | | | |
| AED13 | A20 | | | |
| AED12 | D20 | | | |
| AED11 | B20 | | | |
| AED10 | C20 | | | |
| AED9 | A21 | | | |
| AED8 | D21 | | | |
| AED7 | B21 | | | |
| AED6 | C21 | | | |
| AED5 | A23 | | | |
| AED4 | C22 | | | |
| AED3 | B22 | | | |
| AED2 | B23 | | | |
| AED1 | A24 | | | |
| AED0 | B24 | | | |
| MANAGEMENT DATA INPUT/OUTPUT (MDIO) | | | | |
| XSP_CLK/MDCLK§ | R5 | I/O/Z | IPD | PCI serial interface clock (O) [default] or MDIO serial clock input/output (I/O/Z). |
| XSP_DO/MDIO§ | P5 | I/O/Z | IPU | PCI serial interface data out (O) [default] or MDIO serial data input/output (I/O/Z). In PCI mode, this pin is connected to the input data pin of the serial PROM. |
| TIMER 2 | | | | |
| | – | | | No external pins. The timer 2 peripheral pins are not pinned out as external pins. |
| TIMER 1 | | | | |
| TOUT1/LENDIAN | B5 | O/Z | IPU | Timer 1 output (O/Z) or device endian mode (I). Also controls initialization of DSP modes at reset via pullup/pulldown resistors – Device Endian mode 0 – Big Endian 1 – Little Endian (default) For more details on LENDIAN, see the Device Configurations section of this data sheet. |
| TINP1 | A5 | I | IPD | Timer 1 or general-purpose input |

† I = Input, O = Output, Z = High impedance, S = Supply voltage, GND = Ground

‡ IPD = Internal pulldown, IPU = Internal pullup. (These IPD/IPU signal pins feature a 30-k Ω IPD or IPU resistor. To pull up a signal to the opposite supply rail, a 1-k Ω resistor should be used.)

§ These pins are multiplexed pins. For more details, see the Device Configurations section of this data manual.

¶ PLLV is not part of external voltage supply. See the Clock PLL section for information on how to connect this pin.

A = Analog signal (PLL Filter)

|| The EMU0 and EMU1 pins are internally pulled up with 30-k Ω resistors; therefore, for emulation and normal operation, no external pullup/pulldown resistors are necessary. However, for boundary scan operation, pull down the EMU1 and EMU0 pins with a dedicated 1-k Ω resistor.

Table 2–10. Terminal Functions (Continued)

| SIGNAL NAME | GDK/GNZ | TYPE† | IPD/IPU‡ | DESCRIPTION |
|---|---------|-------|----------|--|
| TIMER 0 | | | | |
| TOUT0/MAC_EN | C5 | O/Z | IPD | Timer 0 output (O/Z) or MAC enable select bit (I) MAC enable pin. This pin and the MAC_EN pin control the selection (enable/disable) of the HPI, EMAC, MDIO, and GP0[15:9], or PCI peripherals. The pins work in conjunction to enable/disable these peripherals (for more details, see the Device Configurations section of this data sheet). For more details, see the Device Configurations section of this data sheet. |
| TINP0 | A4 | I | IPD | Timer 0 or general-purpose input |
| INTER-INTEGRATED CIRCUIT 0 (I2C0) | | | | |
| SCL0 | E4 | I/O/Z | — | I2C0 clock. |
| SDA0 | D3 | I/O/Z | — | I2C0 data. |
| MULTICHANNEL BUFFERED SERIAL PORT 1 (McBSP1) | | | | |
| CLKR1 | AD8 | I/O/Z | IPD | McBSP1 receive clock (I/O/Z) |
| FSR1 | AC7 | I/O/Z | IPD | McBSP1 receive frame sync (I/O/Z) |
| DR1 | AD7 | I | IPD | McBSP1 receive data (I) |
| CLKS1 | AE7 | I | IPD | McBSP1 external clock source (I) (as opposed to internal) |
| DX1 | AC6 | I/O/Z | IPD | McBSP1 transmit data (O/Z) |
| FSX1 | AD6 | I/O/Z | IPD | McBSP1 transmit frame sync (I/O/Z) |
| CLKX1 | AE6 | I/O/Z | IPD | McBSP1 transmit clock (I/O/Z) |
| MULTICHANNEL BUFFERED SERIAL PORT 0 (McBSP0) | | | | |
| CLKR0 | AE15 | I/O/Z | IPD | McBSP0 receive clock (I/O/Z) |
| FSR0 | AB16 | I/O/Z | IPD | McBSP0 receive frame sync (I/O/Z) |
| DR0 | AC16 | I | IPD | McBSP0 receive data (I) |
| CLKS0 | AD16 | I | IPD | McBSP0 external clock source (I) (as opposed to internal) |
| DX0 | AE16 | O/Z | IPD | McBSP0 transmit data (O/Z) |
| FSX0 | AF16 | I/O/Z | IPD | McBSP0 transmit frame sync (I/O/Z) |
| CLKX0 | AF17 | I/O/Z | IPD | McBSP0 transmit clock (I/O/Z) |

† I = Input, O = Output, Z = High impedance, S = Supply voltage, GND = Ground

‡ IPD = Internal pulldown, IPU = Internal pullup. (These IPD/IPU signal pins feature a 30-k Ω IPD or IPU resistor. To pull up a signal to the opposite supply rail, a 1-k Ω resistor should be used.)

§ These pins are multiplexed pins. For more details, see the Device Configurations section of this data manual.

¶ PLLV is not part of external voltage supply. See the Clock PLL section for information on how to connect this pin.

A = Analog signal (PLL Filter)

|| The EMU0 and EMU1 pins are internally pulled up with 30-k Ω resistors; therefore, for emulation and normal operation, no external pullup/pulldown resistors are necessary. However, for boundary scan operation, pull down the EMU1 and EMU0 pins with a dedicated 1-k Ω resistor.

Table 2–10. Terminal Functions (Continued)

| SIGNAL NAME | GDK/ GNZ | TYPE† | IPD/ IPU‡ | DESCRIPTION |
|----------------------------|----------|-------|-----------|---|
| ETHERNET MAC (EMAC) | | | | |
| HD31/AD31/MRCLK§ | G1 | I | | EMAC Media Independent I/F (MII) data, clocks, and control pins for Transmit/Receive. MII transmit clock (MTCLK), Transmit clock source from the attached PHY. MII transmit data (MTXD[3:0]), Transmit data nibble synchronous with transmit clock (MTCLK). MII transmit enable (MTXEN), This signal indicates a valid transmit data on the transmit data pins (MTDX[3:0]). MII collision sense (MCOL) Assertion of this signal during half-duplex operation indicates network collision. During full-duplex operation, transmission of new frames will not begin if this pin is asserted. MII carrier sense (MCRS) Indicates a frame carrier signal is being received. MII receive data (MRXD[3:0]), Receive data nibble synchronous with receive clock (MRCLK). MII receive clock (MRCLK), Receive clock source from the attached PHY. MII receive data valid (MRXDV), This signal indicates a valid data nibble on the receive data pins (MRDX[3:0]). and MII receive error (MRXER), Indicates reception of a coding error on the receive data. |
| HD30/AD30/MCRS§ | H3 | I | | |
| HD29/AD29/MRXER§ | G2 | I | | |
| HD28/AD28/MRXDV§ | J4 | I | | |
| HD27/AD27/MRXD3§ | H2 | I | | |
| HD26/AD26/MRXD2§ | J3 | I | | |
| HD25/AD25/MRXD1§ | J1 | I | | |
| HD24/AD24/MRXD0§ | K4 | I | | |
| HD22/AD22/MTCLK§ | L4 | I | | |
| HD21/AD21/MCOL§ | K2 | I | | |
| HD20/AD20/MTXEN§ | L3 | O/Z | | |
| HD19/AD19/MTXD3§ | L2 | O/Z | | |
| HD18/AD18/MTXD2§ | M4 | O/Z | | |
| HD17/AD17/MTXD1§ | M2 | O/Z | | |
| HD16/AD16/MTXD0§ | M3 | O/Z | | |
| RESERVED FOR TEST | | | | |
| RSV07 | H7 | A | — | Reserved. This pin must be connected directly to CV _{DD} for proper device operation. |
| RSV08 | R6 | A | — | Reserved. This pin must be connected directly to DV _{DD} for proper device operation. |
| RSV46 | A7 | | | Reserved. This pin must be connected directly to CV _{DD} for proper device operation. |
| RSV47 | A13 | | | |
| RSV48 | B8 | | | |
| RSV53 | A9 | | | |
| RSV57 | A10 | | | |
| RSV61 | A11 | | | |

† I = Input, O = Output, Z = High impedance, S = Supply voltage, GND = Ground

‡ IPD = Internal pulldown, IPU = Internal pullup. (These IPD/IPU signal pins feature a 30-kΩ IPD or IPU resistor. To pull up a signal to the opposite supply rail, a 1-kΩ resistor should be used.)

§ These pins are multiplexed pins. For more details, see the Device Configurations section of this data manual.

¶ PLLV is not part of external voltage supply. See the Clock PLL section for information on how to connect this pin.

A = Analog signal (PLL Filter)

|| The EMU0 and EMU1 pins are internally pulled up with 30-kΩ resistors; therefore, for emulation and normal operation, no external pullup/pulldown resistors are necessary. However, for boundary scan operation, pull down the EMU1 and EMU0 pins with a dedicated 1-kΩ resistor.

Table 2–10. Terminal Functions (Continued)

| SIGNAL NAME | GDK/ GNZ | TYPE† | IPD/ IPU‡ | DESCRIPTION |
|-------------------------------|----------|-------|-----------|--|
| RESERVED FOR TEST (CONTINUED) | | | | |
| RSV00 | AA3 | A | — | Reserved (leave unconnected, do not connect to power or ground) |
| RSV01 | AB3 | I | — | |
| RSV02 | AC4 | O/Z | — | |
| RSV05 | E14 | I | IPD | |
| RSV06 | W7 | A | — | |
| RSV09 | AC1 | | | |
| RSV19 | AB15 | | | |
| RSV22 | AB14 | | | |
| RSV25 | AB13 | | | |
| RSV35 | AC8 | | | |
| RSV44 | AB11 | | | |
| RSV45 | AB12 | | | |
| RSV49 | D7 | | | |
| RSV50 | C7 | | | |
| RSV51 | C8 | | | |
| RSV52 | D8 | | | |
| RSV54 | B9 | | | |
| RSV55 | C9 | | | |
| RSV56 | D9 | | | |
| RSV58 | B10 | | | |
| RSV59 | C10 | | | |
| RSV60 | D10 | | | |
| RSV62 | B11 | | | |
| RSV63 | C11 | | | |
| RSV64 | D11 | | | |
| RSV65 | E11 | | | |
| RSV66 | B12 | | | |
| RSV67 | C12 | | | |
| RSV68 | D12 | | | |
| RSV69 | E12 | | | |
| RSV70 | E13 | | | |

† I = Input, O = Output, Z = High impedance, S = Supply voltage, GND = Ground

‡ IPD = Internal pulldown, IPU = Internal pullup. (These IPD/IPU signal pins feature a 30-k Ω IPD or IPU resistor. To pull up a signal to the opposite supply rail, a 1-k Ω resistor should be used.)

§ These pins are multiplexed pins. For more details, see the Device Configurations section of this data manual.

¶ PLLV is not part of external voltage supply. See the Clock PLL section for information on how to connect this pin.

A = Analog signal (PLL Filter)

|| The EMU0 and EMU1 pins are internally pulled up with 30-k Ω resistors; therefore, for emulation and normal operation, no external pullup/pulldown resistors are necessary. However, for boundary scan operation, pull down the EMU1 and EMU0 pins with a dedicated 1-k Ω resistor.

Table 2–10. Terminal Functions (Continued)

| SIGNAL NAME | GDK/ GNZ | TYPE† | IPD/ IPU‡ | DESCRIPTION |
|-------------------------------|----------|-------|-----------|--|
| RESERVED FOR TEST (CONTINUED) | | | | |
| RSV38 | AC9 | | | Reserved (leave unconnected, do not connect to power or ground) |
| RSV40 | AC10 | | | |
| RSV43 | AC11 | | | |
| RSV27 | AC12 | | | |
| RSV24 | AC13 | | | |
| RSV21 | AC14 | | | |
| RSV18 | AC15 | | | |
| RSV13 | AC17 | | | |
| RSV03 | AD3 | O/Z | — | |
| RSV32 | AD5 | | | |
| RSV37 | AD9 | | | |
| RSV39 | AD10 | | | |
| RSV42 | AD11 | | | |
| RSV26 | AD12 | | | |
| RSV23 | AD13 | | | |
| RSV20 | AD14 | | | |
| RSV17 | AD15 | | | |
| RSV14 | AD17 | | | |
| RSV31 | AE5 | | | |
| RSV36 | AE9 | | | |
| RSV41 | AE11 | | | |
| RSV12 | AE17 | | | |
| RSV16 | AE18 | | | |
| RSV04 | AF3 | O | IPU | |
| RSV30 | AF4 | | | |
| RSV33 | AF5 | | | |
| RSV34 | AF6 | | | |
| RSV28 | AF8 | | | |
| RSV29 | AF10 | | | |
| RSV11 | AF12 | | | |
| RSV10 | AF14 | | | |
| RSV15 | AF18 | | | |

† I = Input, O = Output, Z = High impedance, S = Supply voltage, GND = Ground

‡ IPD = Internal pulldown, IPU = Internal pullup. (These IPD/IPU signal pins feature a 30-k Ω IPD or IPU resistor. To pull up a signal to the opposite supply rail, a 1-k Ω resistor should be used.)

§ These pins are multiplexed pins. For more details, see the Device Configurations section of this data manual.

¶ PLLV is not part of external voltage supply. See the Clock PLL section for information on how to connect this pin.

A = Analog signal (PLL Filter)

|| The EMU0 and EMU1 pins are internally pulled up with 30-k Ω resistors; therefore, for emulation and normal operation, no external pullup/pulldown resistors are necessary. However, for boundary scan operation, pull down the EMU1 and EMU0 pins with a dedicated 1-k Ω resistor.

Table 2–10. Terminal Functions (Continued)

| SIGNAL NAME | GDK/ GNZ | TYPE† | IPD/ IPU‡ | DESCRIPTION |
|----------------------------|-------------|-------|--------------|---|
| SUPPLY VOLTAGE PINS | | | | |
| DV _{DD} | A2 | S | | 3.3-V supply voltage (see the Power-Supply Decoupling section of this data manual) |
| | A25 | | | |
| | B1 | | | |
| | B2 | | | |
| | B14 | | | |
| | B25 | | | |
| | B26 | | | |
| | C3 | | | |
| | C24 | | | |
| | D4 | | | |
| | D23 | | | |
| | E5 | | | |
| | E7 | | | |
| | E8 | | | |
| | E10 | | | |
| | E17 | | | |
| | E19 | | | |
| | E20 | | | |
| | E22 | | | |
| | F9 | | | |
| F12 | | | | |
| F15 | | | | |
| F18 | | | | |
| G5 | | | | |
| G22 | | | | |

† I = Input, O = Output, Z = High impedance, S = Supply voltage, GND = Ground

‡ IPD = Internal pulldown, IPU = Internal pullup. (These IPD/IPU signal pins feature a 30-k Ω IPD or IPU resistor. To pull up a signal to the opposite supply rail, a 1-k Ω resistor should be used.)

§ These pins are multiplexed pins. For more details, see the Device Configurations section of this data manual.

¶ PLLV is not part of external voltage supply. See the Clock PLL section for information on how to connect this pin.

A = Analog signal (PLL Filter)

|| The EMU0 and EMU1 pins are internally pulled up with 30-k Ω resistors; therefore, for emulation and normal operation, no external pullup/pulldown resistors are necessary. However, for boundary scan operation, pull down the EMU1 and EMU0 pins with a dedicated 1-k Ω resistor.

Table 2–10. Terminal Functions (Continued)

| SIGNAL NAME | GDK/ GNZ | TYPE† | IPD/ IPU‡ | DESCRIPTION |
|---------------------------------|-------------|-------|--------------|---|
| SUPPLY VOLTAGE PINS (CONTINUED) | | | | |
| DV _{DD} | H5 | S | | 3.3-V supply voltage (see the Power-Supply Decoupling section of this data manual) |
| | H22 | | | |
| | J6 | | | |
| | J21 | | | |
| | K5 | | | |
| | K22 | | | |
| | M6 | | | |
| | M21 | | | |
| | N2 | | | |
| | P25 | | | |
| | R21 | | | |
| | U5 | | | |
| | U22 | | | |
| | V21 | | | |
| | W5 | | | |
| | W22 | | | |
| | W25 | | | |
| | Y5 | | | |
| | Y22 | | | |
| | AA9 | | | |
| | AA12 | | | |
| | AA15 | | | |
| | AA18 | | | |
| | AB5 | | | |
| | AB7 | | | |
| | AB8 | | | |
| AB10 | | | | |
| AB17 | | | | |
| AB19 | | | | |
| AB20 | | | | |
| AB22 | | | | |
| AC23 | | | | |
| AD24 | | | | |
| AE1 | | | | |

† I = Input, O = Output, Z = High impedance, S = Supply voltage, GND = Ground

‡ IPD = Internal pulldown, IPU = Internal pullup. (These IPD/IPU signal pins feature a 30-k Ω IPD or IPU resistor. To pull up a signal to the opposite supply rail, a 1-k Ω resistor should be used.)

§ These pins are multiplexed pins. For more details, see the Device Configurations section of this data manual.

¶ PLLV is not part of external voltage supply. See the Clock PLL section for information on how to connect this pin.

A = Analog signal (PLL Filter)

|| The EMU0 and EMU1 pins are internally pulled up with 30-k Ω resistors; therefore, for emulation and normal operation, no external pullup/pulldown resistors are necessary. However, for boundary scan operation, pull down the EMU1 and EMU0 pins with a dedicated 1-k Ω resistor.

Table 2–10. Terminal Functions (Continued)

| SIGNAL NAME | GDK/ GNZ | TYPE† | IPD/ IPU‡ | DESCRIPTION |
|--|-------------|-------|--------------|--|
| SUPPLY VOLTAGE PINS (CONTINUED) | | | | |
| DV _{DD} | AE2 | S | | 3.3-V supply voltage (see the Power-Supply Decoupling section of this data manual) |
| | AE13 | | | |
| | AE25 | | | |
| | AE26 | | | |
| | AF2 | | | |
| | AF25 | | | |
| CV _{DD} | F6 | S | | 1.2-V supply voltage (-500 device) 1.4 V supply voltage (A-500, A-600, -600, -720 devices) (see the Power-Supply Decoupling section of this data manual) |
| | F7 | | | |
| | F20 | | | |
| | F21 | | | |
| | G6 | | | |
| | G7 | | | |
| | G8 | | | |
| | G10 | | | |
| | G11 | | | |
| | G13 | | | |
| | G14 | | | |
| | G16 | | | |
| | G17 | | | |
| | G19 | | | |
| | G20 | | | |
| | G21 | | | |
| | H20 | | | |
| | K7 | | | |
| | K20 | | | |
| | L7 | | | |
| L20 | | | | |
| M12 | | | | |
| M14 | | | | |

† I = Input, O = Output, Z = High impedance, S = Supply voltage, GND = Ground

‡ IPD = Internal pulldown, IPU = Internal pullup. (These IPD/IPU signal pins feature a 30-k Ω IPD or IPU resistor. To pull up a signal to the opposite supply rail, a 1-k Ω resistor should be used.)

§ These pins are multiplexed pins. For more details, see the Device Configurations section of this data manual.

¶ PLLV is not part of external voltage supply. See the Clock PLL section for information on how to connect this pin.

A = Analog signal (PLL Filter)

|| The EMU0 and EMU1 pins are internally pulled up with 30-k Ω resistors; therefore, for emulation and normal operation, no external pullup/pulldown resistors are necessary. However, for boundary scan operation, pull down the EMU1 and EMU0 pins with a dedicated 1-k Ω resistor.

Table 2–10. Terminal Functions (Continued)

| SIGNAL NAME | GDK/ GNZ | TYPE† | IPD/ IPU‡ | DESCRIPTION |
|---------------------------------|-------------|-------|--------------|--|
| SUPPLY VOLTAGE PINS (CONTINUED) | | | | |
| CV _{DD} | N7 | S | | 1.2-V supply voltage (-500 device) 1.4 V supply voltage (A-500, A-600, -600, -720 devices) (see the Power-Supply Decoupling section of this data manual) |
| | N13 | | | |
| | N15 | | | |
| | N20 | | | |
| | P7 | | | |
| | P12 | | | |
| | P14 | | | |
| | P20 | | | |
| | R13 | | | |
| | R15 | | | |
| | T7 | | | |
| | T20 | | | |
| | U7 | | | |
| | U20 | | | |
| | W20 | | | |
| | Y6 | | | |
| | Y7 | | | |
| | Y8 | | | |
| | Y10 | | | |
| | Y11 | | | |
| | Y13 | | | |
| Y14 | | | | |
| Y16 | | | | |
| Y17 | | | | |
| Y19 | | | | |
| Y20 | | | | |
| Y21 | | | | |
| AA6 | | | | |
| AA7 | | | | |
| AA20 | | | | |
| AA21 | | | | |

† I = Input, O = Output, Z = High impedance, S = Supply voltage, GND = Ground

‡ IPD = Internal pulldown, IPU = Internal pullup. (These IPD/IPU signal pins feature a 30-k Ω IPD or IPU resistor. To pull up a signal to the opposite supply rail, a 1-k Ω resistor should be used.)

§ These pins are multiplexed pins. For more details, see the Device Configurations section of this data manual.

¶ PLLV is not part of external voltage supply. See the Clock PLL section for information on how to connect this pin.

A = Analog signal (PLL Filter)

|| The EMU0 and EMU1 pins are internally pulled up with 30-k Ω resistors; therefore, for emulation and normal operation, no external pullup/pulldown resistors are necessary. However, for boundary scan operation, pull down the EMU1 and EMU0 pins with a dedicated 1-k Ω resistor.

Table 2–10. Terminal Functions (Continued)

| SIGNAL NAME | GDK/GNZ | TYPE† | IPD/IPU‡ | DESCRIPTION |
|--------------------|---------|-------|----------|-------------|
| GROUND PINS | | | | |
| V _{SS} | A1 | GND | | Ground pins |
| | A3 | | | |
| | A6 | | | |
| | A8 | | | |
| | A12 | | | |
| | A14 | | | |
| | A19 | | | |
| | A22 | | | |
| | A26 | | | |
| | B3 | | | |
| | B6 | | | |
| | B7 | | | |
| | B13 | | | |
| | B19 | | | |
| | C2 | | | |
| | C4 | | | |
| | C13 | | | |
| | C18 | | | |
| | C23 | | | |
| | D1 | | | |
| | D2 | | | |
| | D5 | | | |
| | D13 | | | |
| | D18 | | | |
| | D22 | | | |
| | D24 | | | |
| E3 | | | | |
| E6 | | | | |
| E9 | | | | |
| E16 | | | | |
| E18 | | | | |
| E21 | | | | |
| E23 | | | | |

† I = Input, O = Output, Z = High impedance, S = Supply voltage, GND = Ground

‡ IPD = Internal pulldown, IPU = Internal pullup. (These IPD/IPU signal pins feature a 30-k Ω IPD or IPU resistor. To pull up a signal to the opposite supply rail, a 1-k Ω resistor should be used.)

§ These pins are multiplexed pins. For more details, see the Device Configurations section of this data sheet.

¶ PLLV is not part of external voltage supply. See the Clock PLL section for information on how to connect this pin.

A = Analog signal (PLL Filter)

|| The EMU0 and EMU1 pins are internally pulled up with 30-k Ω resistors; therefore, for emulation and normal operation, no external pullup/pulldown resistors are necessary. However, for boundary scan operation, pull down the EMU1 and EMU0 pins with a dedicated 1-k Ω resistor.

Table 2–10. Terminal Functions (Continued)

| SIGNAL NAME | GDK/ GNZ | TYPE† | IPD/ IPU‡ | DESCRIPTION |
|-------------------------|-------------|-------|--------------|-------------|
| GROUND PINS (CONTINUED) | | | | |
| V _{SS} | E26 | GND | | Ground pins |
| | F5 | | | |
| | F8 | | | |
| | F10 | | | |
| | F11 | | | |
| | F13 | | | |
| | F14 | | | |
| | F16 | | | |
| | F17 | | | |
| | F19 | | | |
| | F22 | | | |
| | G9 | | | |
| | G12 | | | |
| | G15 | | | |
| | G18 | | | |
| | H1 | | | |
| | H6 | | | |
| | H21 | | | |
| | H26 | | | |
| | J5 | | | |
| | J7 | | | |
| | J20 | | | |
| | J22 | | | |
| | K6 | | | |
| | K21 | | | |
| | L1 | | | |
| L6 | | | | |
| L21 | | | | |
| M7 | | | | |
| M13 | | | | |
| M15 | | | | |
| M20 | | | | |
| N5 | | | | |
| N6 | | | | |

† I = Input, O = Output, Z = High impedance, S = Supply voltage, GND = Ground

‡ IPD = Internal pulldown, IPU = Internal pullup. (These IPD/IPU signal pins feature a 30-k Ω IPD or IPU resistor. To pull up a signal to the opposite supply rail, a 1-k Ω resistor should be used.)

§ These pins are multiplexed pins. For more details, see the Device Configurations section of this data sheet.

¶ PLLV is not part of external voltage supply. See the Clock PLL section for information on how to connect this pin.

A = Analog signal (PLL Filter)

|| The EMU0 and EMU1 pins are internally pulled up with 30-k Ω resistors; therefore, for emulation and normal operation, no external pullup/pulldown resistors are necessary. However, for boundary scan operation, pull down the EMU1 and EMU0 pins with a dedicated 1-k Ω resistor.

Table 2–10. Terminal Functions (Continued)

| SIGNAL NAME | GDK/ GNZ | TYPE† | IPD/ IPU‡ | DESCRIPTION |
|--------------------------------|-------------|-------|--------------|-------------|
| GROUND PINS (CONTINUED) | | | | |
| V _{SS} | N12 | GND | | Ground pins |
| | N14 | | | |
| | N21 | | | |
| | N25 | | | |
| | P2 | | | |
| | P6 | | | |
| | P13 | | | |
| | P15 | | | |
| | P21 | | | |
| | R7 | | | |
| | R12 | | | |
| | R14 | | | |
| | R20 | | | |
| | T1 | | | |
| | T5 | | | |
| | T6 | | | |
| | T21 | | | |
| | T26 | | | |
| | U6 | | | |
| | U21 | | | |
| | V5 | | | |
| | V7 | | | |
| | V20 | | | |
| | V22 | | | |
| | W1 | | | |
| | W6 | | | |
| W21 | | | | |
| W26 | | | | |
| Y9 | | | | |
| Y12 | | | | |
| Y15 | | | | |
| Y18 | | | | |

† I = Input, O = Output, Z = High impedance, S = Supply voltage, GND = Ground

‡ IPD = Internal pulldown, IPU = Internal pullup. (These IPD/IPU signal pins feature a 30-k Ω IPD or IPU resistor. To pull up a signal to the opposite supply rail, a 1-k Ω resistor should be used.)

§ These pins are multiplexed pins. For more details, see the Device Configurations section of this data sheet.

¶ PLLV is not part of external voltage supply. See the Clock PLL section for information on how to connect this pin.

A = Analog signal (PLL Filter)

|| The EMU0 and EMU1 pins are internally pulled up with 30-k Ω resistors; therefore, for emulation and normal operation, no external pullup/pulldown resistors are necessary. However, for boundary scan operation, pull down the EMU1 and EMU0 pins with a dedicated 1-k Ω resistor.

Table 2–10. Terminal Functions (Continued)

| SIGNAL NAME | GDK/ GNZ | TYPE† | IPD/ IPU‡ | DESCRIPTION |
|-------------------------|----------|-------|-----------|-------------|
| GROUND PINS (CONTINUED) | | | | |
| V_{SS} | AA4 | GND | | Ground pins |
| | AA5 | | | |
| | AA8 | | | |
| | AA10 | | | |
| | AA11 | | | |
| | AA13 | | | |
| | AA14 | | | |
| | AA16 | | | |
| | AA17 | | | |
| | AA19 | | | |
| | AA22 | | | |
| | AB1 | | | |
| | AB2 | | | |
| | AB4 | | | |
| | AB6 | | | |
| | AB9 | | | |
| | AB18 | | | |
| | AB21 | | | |
| | AB26 | | | |
| | AC3 | | | |
| | AC5 | | | |
| | AC18 | | | |
| | AC22 | | | |
| | AC24 | | | |
| AD2 | | | | |
| AD4 | | | | |
| AD18 | | | | |
| AE3 | | | | |
| AE8 | | | | |
| AE10 | | | | |
| AE12 | | | | |

† I = Input, O = Output, Z = High impedance, S = Supply voltage, GND = Ground

‡ IPD = Internal pulldown, IPU = Internal pullup. (These IPD/IPU signal pins feature a 30-k Ω IPD or IPU resistor. To pull up a signal to the opposite supply rail, a 1-k Ω resistor should be used.)

§ These pins are multiplexed pins. For more details, see the Device Configurations section of this data sheet.

¶ PLLV is not part of external voltage supply. See the Clock PLL section for information on how to connect this pin.

A = Analog signal (PLL Filter)

|| The EMU0 and EMU1 pins are internally pulled up with 30-k Ω resistors; therefore, for emulation and normal operation, no external pullup/pulldown resistors are necessary. However, for boundary scan operation, pull down the EMU1 and EMU0 pins with a dedicated 1-k Ω resistor.

Table 2–10. Terminal Functions (Continued)

| SIGNAL NAME | GDK/GNZ | TYPE† | IPD/IPU‡ | DESCRIPTION |
|--------------------------------|---------|-------|----------|-------------|
| GROUND PINS (CONTINUED) | | | | |
| V _{SS} | AE14 | GND | | Ground pins |
| | AE19 | | | |
| | AE24 | | | |
| | AF1 | | | |
| | AF7 | | | |
| | AF9 | | | |
| | AF11 | | | |
| | AF13 | | | |
| | AF15 | | | |
| | AF19 | | | |
| | AF22 | | | |
| | AF26 | | | |

† I = Input, O = Output, Z = High impedance, S = Supply voltage, GND = Ground

‡ IPD = Internal pulldown, IPU = Internal pullup. (These IPD/IPU signal pins feature a 30-k Ω IPD or IPU resistor. To pull up a signal to the opposite supply rail, a 1-k Ω resistor should be used.)

§ These pins are multiplexed pins. For more details, see the Device Configurations section of this data sheet.

¶ PLLV is not part of external voltage supply. See the Clock PLL section for information on how to connect this pin.

A = Analog signal (PLL Filter)

|| The EMU0 and EMU1 pins are internally pulled up with 30-k Ω resistors; therefore, for emulation and normal operation, no external pullup/pulldown resistors are necessary. However, for boundary scan operation, pull down the EMU1 and EMU0 pins with a dedicated 1-k Ω resistor.

2.11 Development Support

TI offers an extensive line of development tools for the TMS320C6000™ DSP platform, including tools to evaluate the performance of the processors, generate code, develop algorithm implementations, and fully integrate and debug software and hardware modules.

The following products support development of C6000™ DSP-based applications:

Software Development Tools:

Code Composer Studio™ Integrated Development Environment (IDE): including Editor C/C++/Assembly Code Generation, and Debug plus additional development tools
Scalable, Real-Time Foundation Software (DSP/BIOS™), which provides the basic run-time target software needed to support any DSP application.

Hardware Development Tools:

Extended Development System (XDS™) Emulator (supports C6000™ DSP multiprocessor system debug)
EVM (Evaluation Module)

For a complete listing of development-support tools for the TMS320C6000™ DSP platform, visit the Texas Instruments web site on the Worldwide Web at <http://www.ti.com> uniform resource locator (URL). For information on pricing and availability, contact the nearest TI field sales office or authorized distributor.

Code Composer Studio, DSP/BIOS, XDS, and TMS320 are trademarks of Texas Instruments.

2.12 Device Support

2.12.1 Device and Development-Support Tool Nomenclature

To designate the stages in the product development cycle, TI assigns prefixes to the part numbers of all DSP devices and support tools. Each DSP commercial family member has one of three prefixes: TMX, TMP, or TMS (e.g., **TMS320C6412AGDK6**). Texas Instruments recommends two of three possible prefix designators for its support tools: TMDX and TMDS. These prefixes represent evolutionary stages of product development from engineering prototypes (TMX/TMDX) through fully qualified production devices/tools (TMS/TMDS).

Device development evolutionary flow:

- TMX** Experimental device that is not necessarily representative of the final device's electrical specifications
- TMP** Final silicon die that conforms to the device's electrical specifications but has not completed quality and reliability verification
- TMS** Fully qualified production device

Support tool development evolutionary flow:

- TMDX** Development-support product that has not yet completed Texas Instruments internal qualification testing.
- TMDS** Fully qualified development-support product

TMX and TMP devices and TMDX development-support tools are shipped against the following disclaimer:

"Developmental product is intended for internal evaluation purposes."

TMS devices and TMDS development-support tools have been characterized fully, and the quality and reliability of the device have been demonstrated fully. TI's standard warranty applies.

Predictions show that prototype devices (TMX or TMP) have a greater failure rate than the standard production devices. Texas Instruments recommends that these devices not be used in any production system because their expected end-use failure rate still is undefined. Only qualified production devices are to be used.

TI device nomenclature also includes a suffix with the device family name. This suffix indicates the package type (for example, GDK), the temperature range (for example, blank is the default commercial temperature range), and the device speed range in megahertz (for example, -6 is 600 MHz). Figure 2-7 provides a legend for reading the complete device name for any DSP platform member.

The ZDK package, like the GDK package, is a 548-ball plastic BGA *only* with Pb-free balls. The ZNZ package is the Pb-free version of the GNZ package. For device part numbers and further ordering information for TMS320C6412 in the GDK, GNZ, ZDK and ZNZ package types, see the TI website (<http://www.ti.com>) or contact your TI sales representative.

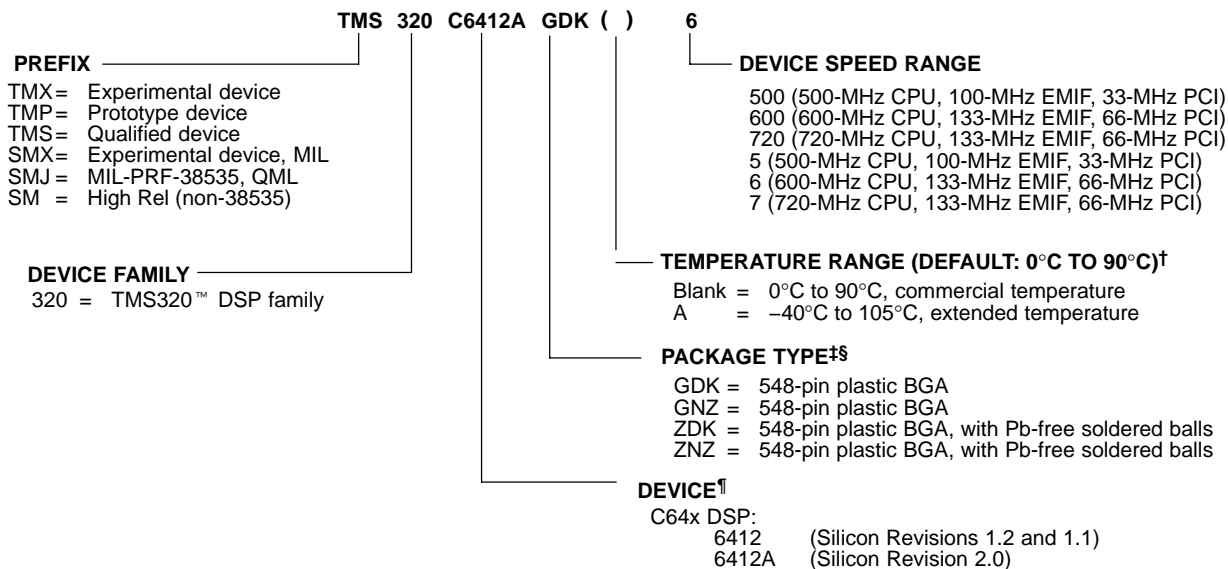

[†] The extended temperature "A version" devices may have different operating conditions than the commercial temperature devices. For more details, see the recommended operating conditions portion of this data sheet.

[‡] BGA = Ball Grid Array

[§] The ZDK and ZNZ mechanical package designators represent the version of the GDK and GNZ packages with Pb-free balls. For more detailed information, see the *Mechanical Data* section of this document.

[¶] For actual device part numbers (P/Ns) and ordering information, see the TI website (www.ti.com).

Figure 2–7. TMS320C64x™ DSP Device Nomenclature (Including the TMS320C6412 Device)

For additional information, see the *TMS320C6412 Digital Signal Processor Silicon Errata* (literature number SPRZ199).

2.12.2 Documentation Support

Extensive documentation supports all TMS320™ DSP family generations of devices from product announcement through applications development. The types of documentation available include: data sheets, such as this document, with design specifications; complete user's reference guides for all devices and tools; technical briefs; development-support tools; on-line help; and hardware and software applications. The following is a brief, descriptive list of support documentation specific to the C6000™ DSP devices:

The *TMS320C6000 CPU and Instruction Set Reference Guide* (literature number SPRU189) describes the C6000™ DSP CPU (core) architecture, instruction set, pipeline, and associated interrupts.

The *TMS320C6000 DSP Peripherals Overview Reference Guide* (literature number SPRU190) provides an overview and briefly describes the functionality of the peripherals available on the C6000™ DSP platform of devices. This document also includes a table listing the peripherals available on the C6000 devices along with literature numbers and hyperlinks to the associated peripheral documents.

The *TMS320C64x Technical Overview* (literature number SPRU395) gives an introduction to the C64x™ digital signal processor, and discusses the application areas that are enhanced by the C64x™ DSP *VelociTI.2™* VLIW architecture.

TMS320C6000 DSP Inter-Integrated Circuit (I2C) Module Peripheral Reference Guide (literature number SPRU175) describes the functionality of the I²C peripheral.

TMS320C6000 DSP Ethernet Media Access Controller (EMAC)/ Management Data Input/Output (MDIO) Module Reference Guide (literature number SPRU628) describes the functionality of the EMAC and MDIO peripherals.

The *TMS320C6412 Digital Signal Processor Silicon Errata* (literature number SPRZ199) describes the known exceptions to the functional specifications for particular silicon revisions of the TMS320C6412 device.

The *TMS320C6412 Power Consumption Summary* application report (literature number SPRA967) discusses the power consumption for user applications with the TMS320C6412 DSP device.

The *TMS320C6412 Hardware Designer's Resource Guide* (literature number SPRAA34) is organized by development flow and functional areas to make design efforts as seamless as possible. This document includes getting started, board design, system testing, and checklists to aid in initial designs and debug efforts. Each section of this document includes pointers to valuable information including: technical documentation, models, symbols, and reference designs for use in each phase of design. Particular attention is given to peripheral interfacing and system-level design concerns.

The *Using IBIS Models for Timing Analysis* application report (literature number SPRA839) describes how to properly use IBIS models to attain accurate timing analysis for a given system.

The tools support documentation is electronically available within the Code Composer Studio™ Integrated Development Environment (IDE). For a complete listing of C6000™ DSP latest documentation, visit the Texas Instruments web site on the Worldwide Web at <http://www.ti.com> uniform resource locator (URL).

2.12.2.1 Device Silicon Revision

The device silicon revision can be determined by the "Die PG code" marked on the top of the package. For more detailed information on the DM642 silicon revision, package markings, and the known exceptions to the functional specifications as well as any usage notes, refer to the device-specific silicon errata: *TMS320C6412 Digital Signal Processor Silicon Errata* (literature number SPRZ199).

2.13 Clock PLL

Most of the internal C64x™ DSP clocks are generated from a single source through the CLKIN pin. This source clock either drives the PLL, which multiplies the source clock frequency to generate the internal CPU clock, or bypasses the PLL to become the internal CPU clock.

To use the PLL to generate the CPU clock, the external PLL filter circuit must be properly designed. Figure 2–8 shows the external PLL circuitry for either x1 (PLL bypass) or other PLL multiply modes.

To minimize the clock jitter, a single clean power supply should power both the C64x™ DSP device and the external clock oscillator circuit. The minimum CLKIN rise and fall times should also be observed. For the input clock timing requirements, see the *input and output clocks* electricals section.

Rise/fall times, duty cycles (high/low pulse durations), and the load capacitance of the external clock source must meet the DSP requirements in this data sheet (see the *electrical characteristics over recommended ranges of supply voltage and operating case temperature* table and the *input and output clocks* electricals section).

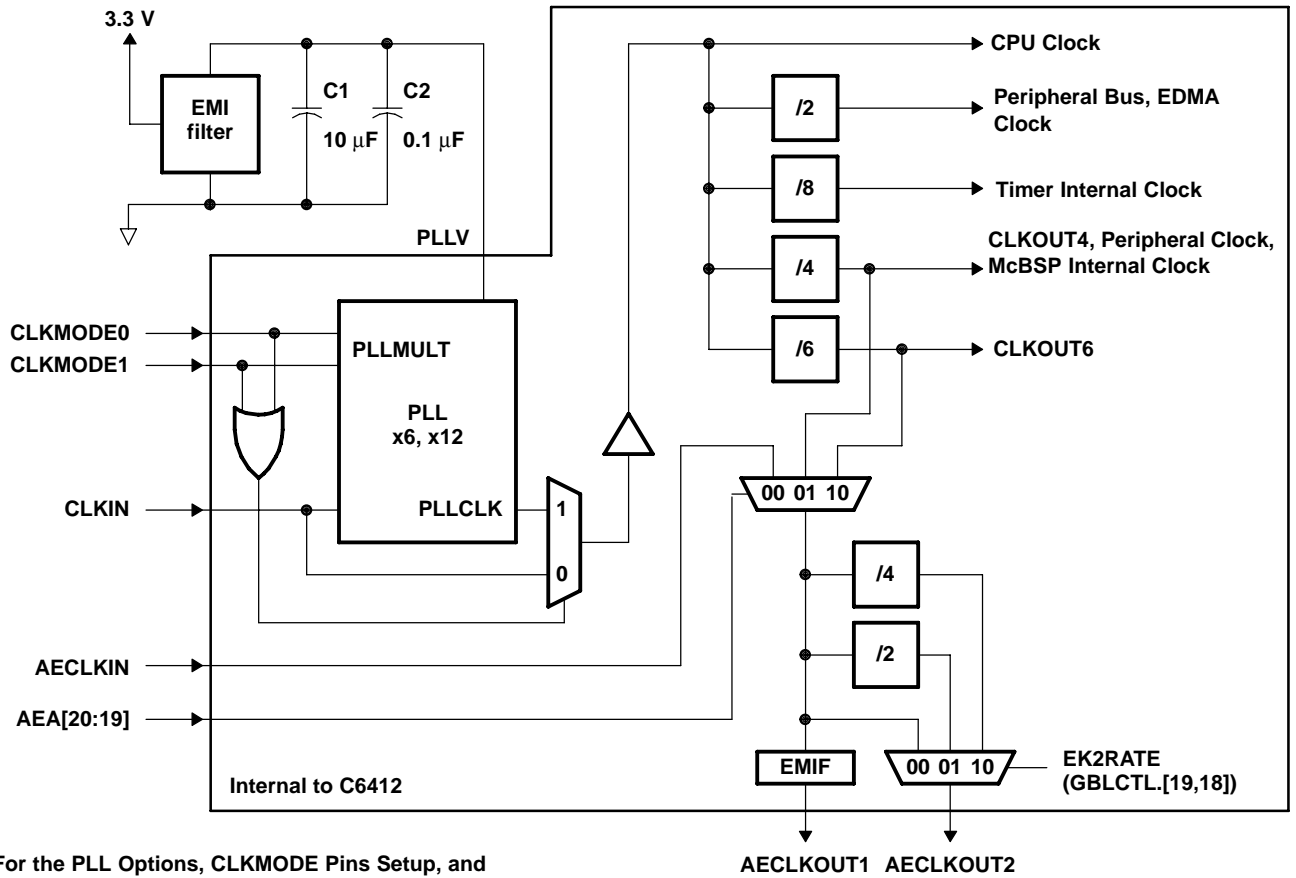

(For the PLL Options, CLKMODE Pins Setup, and PLL Clock Frequency Ranges, see Table 9.)

- NOTES:
- A. Place all PLL external components (C1, C2, and the EMI Filter) as close to the C6000™ DSP device as possible. For the best performance, TI recommends that all the PLL external components be on a single side of the board without jumpers, switches, or components other than the ones shown.
 - B. For reduced PLL jitter, maximize the spacing between switching signals and the PLL external components (C1, C2, and the EMI Filter).
 - C. The 3.3-V supply for the EMI filter must be from the same 3.3-V power plane supplying the I/O voltage, DV_{DD}.
 - D. EMI filter manufacturer TDK part number ACF451832-333, -223, -153, -103. Panasonic part number EXCCET103U.

Figure 2–8. External PLL Circuitry for Either PLL Multiply Modes or x1 (Bypass) Mode

Table 2–11. TMS320C6412 PLL Multiply Factor Options, Clock Frequency Ranges, and Typical Lock Time^{†‡}

| GDK and ZDK PACKAGES – 23 x 23 mm BGA, GNZ and ZNZ PACKAGES – 27 x 27 mm BGA | | | | | | | |
|---|----------|--------------------------------------|-------------------------|---------------------------------------|------------------------|------------------------|---|
| CLKMODE1 | CLKMODE0 | CLKMODE (PLL MULTIPLY FACTORS) | CLKIN RANGE (MHz) | CPU CLOCK FREQUENCY RANGE (MHz) | CLKOUT4 RANGE (MHz) | CLKOUT6 RANGE (MHz) | TYPICAL LOCK TIME (μ s) [§] |
| 0 | 0 | Bypass (x1) | 30–75 | 30–75 | 7.5–18.8 | 5–12.5 | N/A |
| 0 | 1 | x6 | 30–75 | 180–450 | 45–112.5 | 30–75 | 75 |
| 1 | 0 | x12 | 30–60 | 360–720 | 90–180 | 60–120 | |
| 1 | 1 | Reserved | – | – | – | – | – |

[†] These clock frequency range values are applicable to a C6412–720 speed device. For –500 and –600 device speed values, see the CLKIN timing requirements table for the specific device speed.

[‡] Use external pullup resistors on the CLKMODE pins (CLKMODE1 and CLKMODE0) to set the C6412 device to one of the valid PLL multiply clock modes (x6 or x12). With internal pulldown resistors on the CLKMODE pins (CLKMODE1, CLKMODE0), the default clock mode is x1 (bypass).

[§] Under some operating conditions, the maximum PLL lock time may vary by as much as 150% from the specified typical value. For example, if the typical lock time is specified as 100 μ s, the maximum value may be as long as 250 μ s.

2.14 I2C

The I2C module on the TMS320C6412 may be used by the DSP to control local peripherals ICs (DACs, ADCs, etc.) while the other may be used to communicate with other controllers in a system or to implement a user interface.

The I2C port supports:

- Compatible with Philips I2C Specification Revision 2.1 (January 2000)
- Fast Mode up to 400 Kbps (no fail-safe I/O buffers)
- Noise Filter to Remove Noise 50 ns or less
- Seven- and Ten-Bit Device Addressing Modes
- Master (Transmit/Receive) and Slave (Transmit/Receive) Functionality
- Events: DMA, Interrupt, or Polling
- Slew-Rate Limited Open-Drain Output Buffers

Figure 2–9 is a block diagram of the I2C0 module.

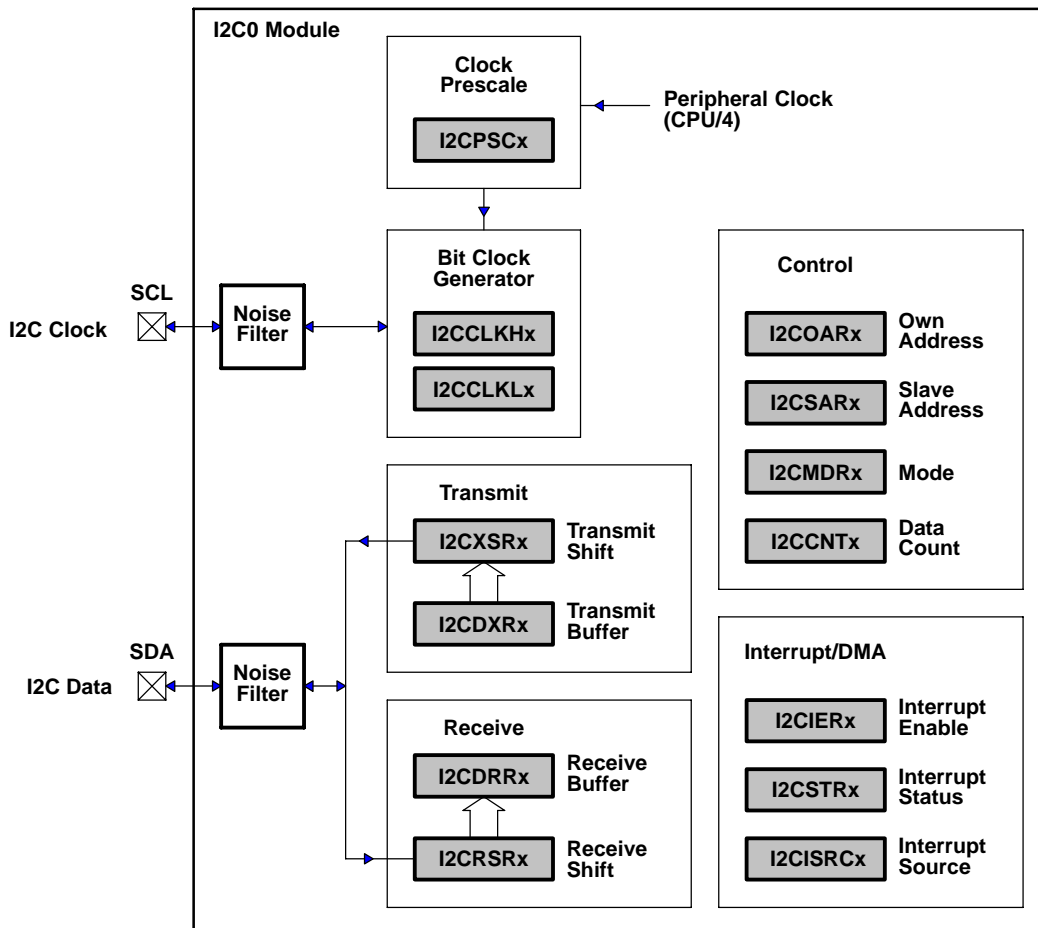

NOTE A: Shading denotes control/status registers.

Figure 2–9. I2C0 Module Block Diagram

2.15 PCI

On the C6412 device, the PCI interface is multiplexed with the 32-bit Host Port Interface (HPI), or with a combination of 16-bit HPI and EMAC/MDIO. This provides the following flexibility options to the user:

- 32-bit 66 MHz PCI bus
- 32-bit HPI
- Combination of 16-bit HPI and EMAC/MDIO

The PCI port for the TMS320C6000 supports connection of the DSP to a PCI host via the integrated PCI master/slave bus interface. For the C64x devices, like the C6412, the PCI port interfaces to the DSP via the EDMA internal address generation hardware. This architecture allows for both PCI Master and Slave transactions, while keeping the EDMA channel resources available for other applications.

For more details on the PCI port peripheral module, see the *TMS320C6000 DSP Peripheral Component Interconnect (PCI) Reference Guide* (literature number SPRU581).

2.16 EMAC

The ethernet media access controller (EMAC) provides an efficient interface between the C6412 DSP core processor and the network. The C6412 EMAC support both 10Base-T and 100Base-TX, or 10 Mbits/second (Mbps) and 100 Mbps in either half- or full-duplex, with hardware flow control and quality of service (QOS) support. The C6412 EMAC makes use of a custom interface to the DSP core that allows efficient data transmission and reception.

The EMAC controls the flow of packet data from the DSP to the PHY. The MDIO module controls PHY configuration and status monitoring.

Both the EMAC and the MDIO modules interface to the DSP through a custom interface that allows efficient data transmission and reception. This custom interface is referred to as the EMAC control module, and is considered integral to the EMAC/MDIO peripheral. The control module is also used to control device reset, interrupts, and system priority.

The *TMS320C6000 DSP Ethernet Media Access Controller (EMAC) / Management Data Input/Output (MDIO) Module Reference Guide* (literature number SPRU628) describes the C6412 EMAC peripheral in detail. Some of the features documented in this peripheral reference guide are not supported on the C6412 at this time. The C6412 supports one receive channel and does not support receive quality of service (QOS). For a list of supported registers and register fields, see Table 1–9 [Ethernet MAC (EMAC) Control Registers] and Table 1–10 [EMAC Statistics Registers] in this data manual.

2.17 MDIO

The management data input/output (MDIO) module continuously polls all 32 MDIO addresses in order to enumerate all PHY devices in the system.

The management data input/output (MDIO) module implements the 802.3 serial management interface to interrogate and control Ethernet PHY(s) using a shared two-wire bus. Host software uses the MDIO module to configure the auto-negotiation parameters of each PHY attached to the EMAC, retrieve the negotiation results, and configure required parameters in the EMAC module for correct operation. The module is designed to allow almost transparent operation of the MDIO interface, with very little maintenance from the core processor.

The *TMS320C6000 DSP Ethernet Media Access Controller (EMAC) / Management Data Input/Output (MDIO) Module Reference Guide* (literature number SPRU628) describes the C6412 MDIO peripheral in detail. Some of the features documented in this peripheral reference guide are not supported on the C6412 at this time. The C6412 only supports one EMAC module. For a list of supported registers and register fields, see Table 1–22 [MDIO Registers] in this data manual.

2.18 General-Purpose Input/Output (GPIO)

To use the GP[15:0] software-configurable GPIO pins, the GPxEN bits in the GP Enable (GPEN) Register and the GPxDIR bits in the GP Direction (GPDIR) Register must be properly configured.

GPxEN = 1 GP[x] pin is enabled

GPxDIR = 0 GP[x] pin is an input

GPxDIR = 1 GP[x] pin is an output

where “x” represents one of the 15 through 0 GPIO pins

Figure 2–10 shows the GPIO enable bits in the GPEN register for the C6412 device. To use any of the GPx pins as general-purpose input/output functions, the corresponding GPxEN bit must be set to “1” (enabled). Default values are device-specific, so refer to Figure 2–10 for the C6412 default configuration.

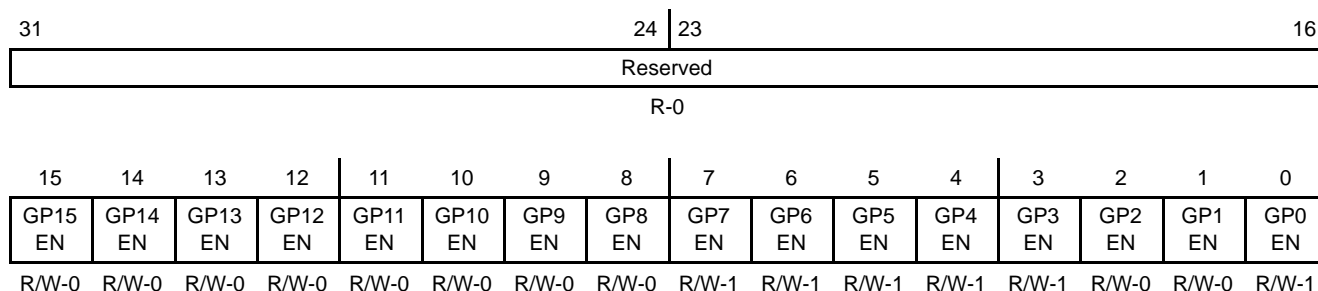

Legend: R/W = Readable/Writeable; -n = value after reset, -x = undefined value after reset

Figure 2–10. GPIO Enable Register (GPEN) [Hex Address: 01B0 0000]

Figure 2–11 shows the GPIO direction bits in the GPDIR register. This register determines if a given GPIO pin is an input or an output providing the corresponding GPxEN bit is enabled (set to “1”) in the GPEN register. By default, all the GPIO pins are configured as input pins.

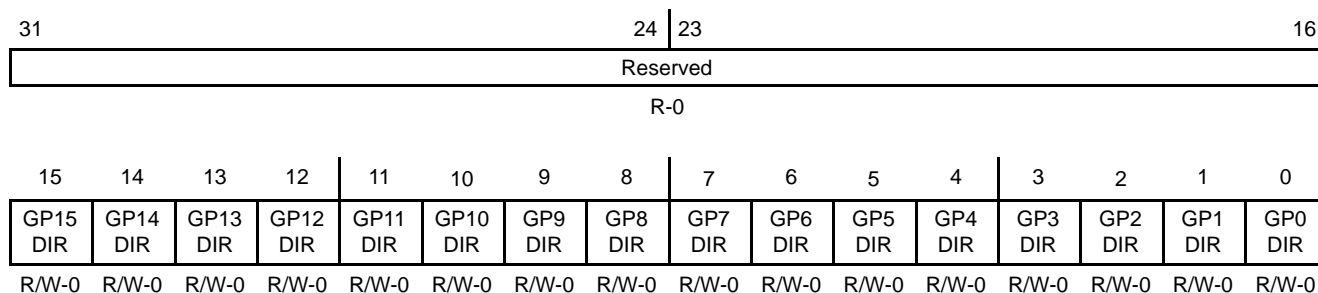

Legend: R/W = Readable/Writeable; -n = value after reset, -x = undefined value after reset

Figure 2–11. GPIO Direction Register (GPDIR) [Hex Address: 01B0 0004]

For more detailed information on general-purpose inputs/outputs (GPIOs), see the *TMS320C6000 DSP General-Purpose Input/Output (GPIO) Reference Guide* (literature number SPRU584).

2.19 Power-Down Modes Logic

Figure 2–12 shows the power-down mode logic on the C6412.

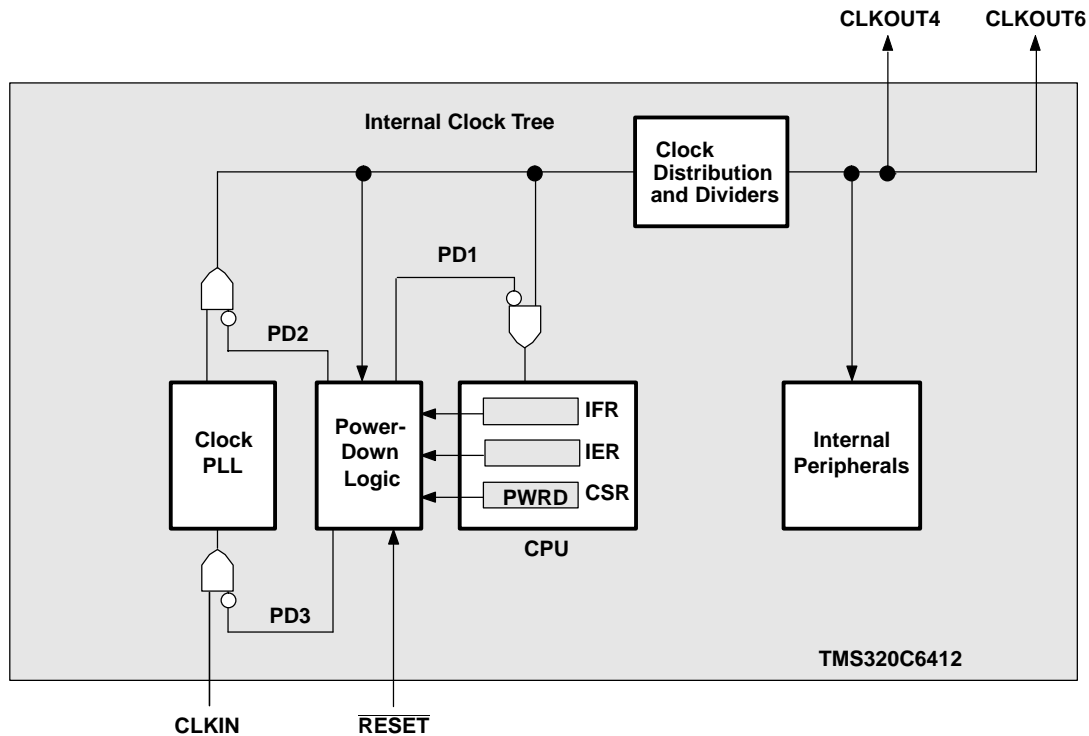

† External input clocks, with the exception of CLKIN, are *not* gated by the power-down mode logic.

Figure 2–12. Power-Down Mode Logic†

2.19.1 Triggering, Wake-up, and Effects

The power-down modes and their wake-up methods are programmed by setting the PWRD field (bits 15–10) of the control status register (CSR). The PWRD field of the CSR is shown in Figure 2–13 and described in Table 2–12. When writing to the CSR, all bits of the PWRD field should be set at the same time. Logic 0 should be used when writing to the reserved bit (bit 15) of the PWRD field. The CSR is discussed in detail in the *TMS320C6000 CPU and Instruction Set Reference Guide* (literature number SPRU189).

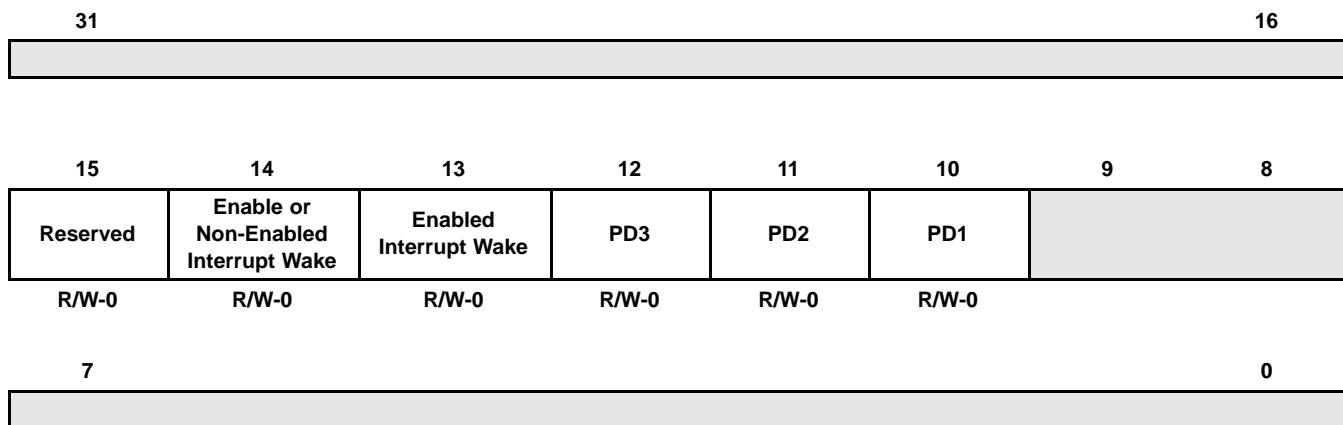

Legend: R/W-x = Read/write reset value

NOTE: The shadowed bits are not part of the power-down logic discussion and therefore are not covered here. For information on these other bit fields in the CSR register, see the *TMS320C6000 CPU and Instruction Set Reference Guide* (literature number SPRU189).

Figure 2-13. PWRD Field of the CSR Register

A delay of up to nine clock cycles may occur after the instruction that sets the PWRD bits in the CSR before the PD mode takes effect. As best practice, NOPs should be padded after the PWRD bits are set in the CSR to account for this delay.

If PD1 mode is terminated by a non-enabled interrupt, the program execution returns to the instruction where PD1 took effect. If PD1 mode is terminated by an enabled interrupt, the interrupt service routine will be executed first, then the program execution returns to the instruction where PD1 took effect. In the case with an enabled interrupt, the GIE bit in the CSR and the NMIE bit in the interrupt enable register (IER) must also be set in order for the interrupt service routine to execute; otherwise, execution returns to the instruction where PD1 took effect upon PD1 mode termination by an enabled interrupt.

PD2 and PD3 modes can only be aborted by device reset. Table 2-12 summarizes all the power-down modes.

Table 2–12. Characteristics of the Power-Down Modes

| PRWD FIELD (BITS 15–10) | POWER-DOWN MODE | WAKE-UP METHOD | EFFECT ON CHIP'S OPERATION |
|-------------------------|------------------|---|--|
| 000000 | No power-down | — | — |
| 001001 | PD1 | Wake by an enabled interrupt | CPU halted (except for the interrupt logic) Power-down mode blocks the internal clock inputs at the boundary of the CPU, preventing most of the CPU's logic from switching. During PD1, EDMA transactions can proceed between peripherals and internal memory. |
| 010001 | PD1 | Wake by an enabled or non-enabled interrupt | |
| 011010 | PD2 [†] | Wake by a device reset | Output clock from PLL is halted, stopping the internal clock structure from switching and resulting in the entire chip being halted. All register and internal RAM contents are preserved. All functional I/O "freeze" in the last state when the PLL clock is turned off. |
| 011100 | PD3 [†] | Wake by a device reset | Input clock to the PLL stops generating clocks. All register and internal RAM contents are preserved. All functional I/O "freeze" in the last state when the PLL clock is turned off. Following reset, the PLL needs time to re-lock, just as it does following power-up. Wake-up from PD3 takes longer than wake-up from PD2 because the PLL needs to be re-locked, just as it does following power-up. |
| All others | Reserved | — | — |

[†] When entering PD2 and PD3, all functional I/O remains in the previous state. However, for peripherals which are asynchronous in nature or peripherals with an external clock source, output signals may transition in response to stimulus on the inputs. Under these conditions, peripherals will not operate according to specifications.

2.19.2 C64x Power-Down Mode with an Emulator

If user power-down modes are programmed, and an emulator is attached, the modes will be masked to allow the emulator access to the system. This condition prevails until the emulator is reset or the cable is removed from the header. If power measurements are to be performed when in a power-down mode, the emulator cable should be removed.

When the DSP is in power-down mode PD2 or PD3, emulation logic will force any emulation execution command (such as Step or Run) to spin in IDLE. For this reason, PC writes (such as loading code) will fail. A DSP reset will be required to get the DSP out of PD2/PD3.

2.20 Power-Supply Sequencing

TI DSPs do not require specific power sequencing between the core supply and the I/O supply. However, systems should be designed to ensure that neither supply is powered up for extended periods of time (>1 second) if the other supply is below the proper operating voltage.

2.20.1 Power-Supply Design Considerations

A dual-power supply with simultaneous sequencing can be used to eliminate the delay between core and I/O power up. A Schottky diode can also be used to tie the core rail to the I/O rail (see Figure 2–14).

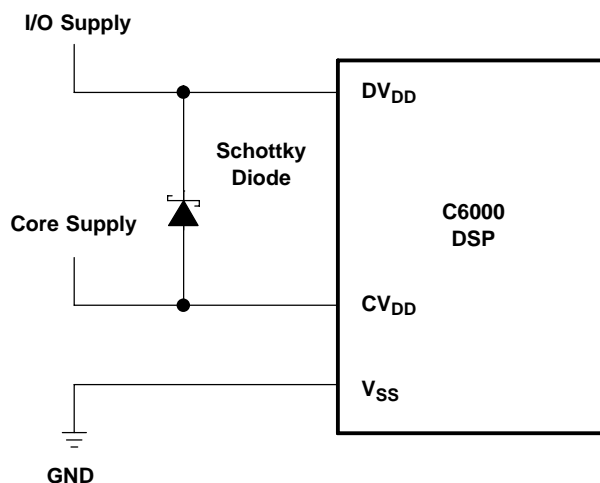

Figure 2–14. Schottky Diode Diagram

Core and I/O supply voltage regulators should be located close to the DSP (or DSP array) to minimize inductance and resistance in the power delivery path. Additionally, when designing for high-performance applications utilizing the C6000™ platform of DSPs, the PC board should include separate power planes for core, I/O, and ground, all bypassed with high-quality low-ESL/ESR capacitors.

TI DSPs do not require specific power sequencing between the core supply and the I/O supply. However, systems should be designed to ensure that neither supply is powered up for extended periods of time if the other supply is below the proper operating voltage.

2.20.2 Power-Supply Decoupling

In order to properly decouple the supply planes from system noise, place as many capacitors (caps) as possible close to the DSP. Assuming 0603 caps, the user should be able to fit a total of 60 caps, 30 for the core supply and 30 for the I/O supply. These caps need to be close to the DSP power pins, no more than 1.25 cm maximum distance to be effective. Physically smaller caps, such as 0402, are better because of their lower parasitic inductance. Proper capacitance values are also important. Small bypass caps (near 560 pF) should be closest to the power pins. Medium bypass caps (220 nF or as large as can be obtained in a small package) should be next closest. TI recommends no less than 8 small and 8 medium caps per supply (32 total) be placed immediately next to the BGA vias, using the “interior” BGA space and at least the corners of the “exterior”.

Eight larger caps (4 for each supply) can be placed further away for bulk decoupling. Large bulk caps (on the order of 100 μ F) should be furthest away (but still as close as possible). No less than 4 large caps per supply (8 total) should be placed outside of the BGA.

Any cap selection needs to be evaluated from a yield/manufacturing point-of-view. As with the selection of any component, verification of capacitor availability over the product’s production lifetime should be considered.

2.21 Power-Down Operation

The C6412 device can be powered down in three ways:

- Power-down due to pin configuration
- Power-down due to software configuration – relates to the default state of the peripheral configuration bits in the PERCFG register.
- Power-down during run-time via software configuration

On the C6412 device, the HPI, PCI, and EMAC and MDIO peripherals are controlled (selected) at the pin level during chip reset (e.g., PCI_EN, HD5, and MAC_EN pins).

The McBSP0, McBSP1, and I2C0 peripheral functions are selected via the peripheral configuration (PERCFG) register bits.

For more detailed information on the peripheral configuration pins and the PERCFG register bits, see the Device Configurations section of this document.

2.22 IEEE 1149.1 JTAG Compatibility Statement

The TMS320C6412 DSP requires that both $\overline{\text{TRST}}$ and $\overline{\text{RESET}}$ be asserted upon power up to be properly initialized. While $\overline{\text{RESET}}$ initializes the DSP core, $\overline{\text{TRST}}$ initializes the DSP's emulation logic. Both resets are required for proper operation.

Note: $\overline{\text{TRST}}$ is synchronous and **must** be clocked by TCLK; otherwise, BSCAN may not respond as expected after $\overline{\text{TRST}}$ is asserted.

While both $\overline{\text{TRST}}$ and $\overline{\text{RESET}}$ need to be asserted upon power up, only $\overline{\text{RESET}}$ needs to be released for the DSP to boot properly. $\overline{\text{TRST}}$ may be asserted indefinitely for normal operation, keeping the JTAG port interface and DSP's emulation logic in the reset state. $\overline{\text{TRST}}$ only needs to be released when it is necessary to use a JTAG controller to debug the DSP or exercise the DSP's boundary scan functionality. $\overline{\text{RESET}}$ must be released in order for boundary-scan JTAG to read the variant field of IDCODE correctly. Other boundary-scan instructions work correctly independent of current state of $\overline{\text{RESET}}$.

The TMS320C6412 DSP includes an internal pulldown (IPD) on the $\overline{\text{TRST}}$ pin to ensure that $\overline{\text{TRST}}$ will always be asserted upon power up and the DSP's internal emulation logic will always be properly initialized when this pin is not routed out. JTAG controllers from Texas Instruments actively drive $\overline{\text{TRST}}$ high. However, some third-party JTAG controllers may not drive $\overline{\text{TRST}}$ high but expect the use of an external pullup resistor on $\overline{\text{TRST}}$. When using this type of JTAG controller, assert $\overline{\text{TRST}}$ to initialize the DSP after powerup and externally drive $\overline{\text{TRST}}$ high before attempting any emulation or boundary scan operations.

Following the release of $\overline{\text{RESET}}$, the low-to-high transition of $\overline{\text{TRST}}$ must be "seen" to latch the state of EMU1 and EMU0. The EMU[1:0] pins configure the device for either Boundary Scan mode or Normal/Emulation mode. For more detailed information, see the terminal functions section of this data sheet.

Note: The DESIGN_WARNING section of the TMS320C6412 BSDL file contains information and constraints regarding proper device operation while in Boundary Scan Mode.

For more detailed information on the C6412 JTAG emulation, see the *TMS320C6000 DSP Designing for JTAG Emulation Reference Guide* (literature number SPRU641).

2.23 EMIF Device Speed

The rated EMIF speed of these devices only applies to the SDRAM interface when in a system that meets the following requirements:

- 1 chip-enable (CE) space (maximum of 2 chips) of SDRAM connected to EMIF
- up to 1 CE space of buffers connected to EMIF
- EMIF trace lengths between 1 and 3 inches
- 166-MHz SDRAM for 133-MHz operation
- 143-MHz SDRAM for 100-MHz operation

Other configurations may be possible, but timing analysis must be done to verify all AC timings are met. Verification of AC timings is mandatory when using configurations other than those specified above. TI recommends utilizing I/O buffer information specification (IBIS) to analyze all AC timings.

To properly use IBIS models to attain accurate timing analysis for a given system, see the *Using IBIS Models for Timing Analysis* application report (literature number SPRA839).

To maintain signal integrity, serial termination resistors should be inserted into all EMIF output signal lines (see the Terminal Functions table for the EMIF output signals).

For more detailed information on the C6412 EMIF peripheral, see the *TMS320C6000 DSP External Memory Interface (EMIF) Reference Guide* (literature number SPRU266).

2.24 Bootmode

The C6412 device resets using the active-low signal $\overline{\text{RESET}}$. While $\overline{\text{RESET}}$ is low, the device is held in reset and is initialized to the prescribed reset state. Refer to reset timing for reset timing characteristics and states of device pins during reset. The release of $\overline{\text{RESET}}$ starts the processor running with the prescribed device configuration and boot mode.

The C6412 has three types of boot modes:

- Host boot

If host boot is selected, upon release of $\overline{\text{RESET}}$, the CPU is internally “stalled” while the remainder of the device is released. During this period, an external host can initialize the CPU’s memory space as necessary through the host interface, including internal configuration registers, such as those that control the EMIF or other peripherals. For the C6412 device, the HPI peripheral is used for host boot if $\text{PCI_EN} = 0$, and the PCI peripheral is used if $\text{PCI_EN} = 1$. Once the host is finished with all necessary initialization, it must set the DSPINT bit in the HPIC register to complete the boot process. This transition causes the boot configuration logic to bring the CPU out of the “stalled” state. The CPU then begins execution from address 0. The DSPINT condition is not latched by the CPU, because it occurs while the CPU is still internally “stalled”. Also, DSPINT brings the CPU out of the “stalled” state only if the host boot process is selected. All memory may be written to and read by the host. This allows for the host to verify what it sends to the DSP if required. After the CPU is out of the “stalled” state, the CPU needs to clear the DSPINT, otherwise, no more DSPINTs can be received.

- EMIF boot (using default ROM timings)

Upon the release of $\overline{\text{RESET}}$, the 1K-Byte ROM code located in the beginning of $\overline{\text{ACE1}}$ is copied to address 0 by the EDMA using the default ROM timings, while the CPU is internally “stalled”. The data should be stored in the endian format that the system is using. In this case, the EMIF automatically assembles consecutive 8-bit bytes to form the 32-bit instruction words to be copied. The transfer is automatically done by the EDMA as a single-frame block transfer from the ROM to address 0. After completion of the block transfer, the CPU is released from the “stalled” state and starts running from address 0.

- No boot

With no boot, the CPU begins direct execution from the memory located at address 0. Note: operation is undefined if invalid code is located at address 0.

2.25 Reset

A hardware reset ($\overline{\text{RESET}}$) is required to place the DSP into a known good state out of power-up. The $\overline{\text{RESET}}$ signal can be asserted (pulled low) prior to ramping the core and I/O voltages or after the core and I/O voltages have reached their proper operating conditions. As a best practice, reset should be held low during power-up. Prior to deasserting $\overline{\text{RESET}}$ (low-to-high transition), the core and I/O voltages should be at their proper operating conditions and CLKIN should also be running at the correct frequency.

3 Electrical Specifications

3.1 Absolute Maximum Ratings Over Operating Case Temperature Range (Unless Otherwise Noted)[†]

| | | |
|--|---|-----------------------------|
| Supply voltage ranges: | CV_{DD} (see Note 1) | - 0.3 V to 1.8 V |
| | DV_{DD} (see Note 1) | -0.3 V to 4 V |
| Input voltage ranges: | (except PCI), V_I | -0.3 V to 4 V |
| | (PCI), V_{IP} | -0.5 V to $DV_{DD} + 0.5$ V |
| Output voltage ranges: | (except PCI), V_O | -0.3 V to 4 V |
| | (PCI), V_{OP} | -0.5 V to $DV_{DD} + 0.5$ V |
| Operating case temperature ranges, T_C : | (default) | 0°C to 90°C |
| | (A version) [A-500 and A-600] | -40°C to 105°C |
| Storage temperature range, T_{stg} | | -65°C to 150°C |
| Package Temperature Cycling: | Temperature Range | -40°C to 125°C |
| | Number of Cycles | 500 |

[†] Stresses beyond those listed under “absolute maximum ratings” may cause permanent damage to the device. These are stress ratings only, and functional operation of the device at these or any other conditions beyond those indicated under “recommended operating conditions” is not implied. Exposure to absolute-maximum-rated conditions for extended periods may affect device reliability.

NOTE 1: All voltage values are with respect to V_{SS} .

3.2 Recommended Operating Conditions

| | | MIN | NOM | MAX | UNIT |
|-----------|--|-----------------------------|-----|-----------------|------|
| CV_{DD} | Supply voltage, Core (-500 device) [‡] | 1.14 | 1.2 | 1.26 | V |
| CV_{DD} | Supply voltage, Core (A-500, A-600, -600, -720 devices) [‡] | 1.36 | 1.4 | 1.44 | V |
| DV_{DD} | Supply voltage, I/O | 3.14 | 3.3 | 3.46 | V |
| V_{SS} | Supply ground | 0 | 0 | 0 | V |
| V_{IH} | High-level input voltage (except PCI) | 2 | | | V |
| V_{IL} | Low-level input voltage (except PCI) | | | 0.8 | V |
| V_{IP} | Input voltage (PCI) | -0.5 | | $DV_{DD} + 0.5$ | V |
| V_{IHP} | High-level input voltage (PCI) | $0.5DV_{DD}$ | | $DV_{DD} + 0.5$ | V |
| V_{ILP} | Low-level input voltage (PCI) | -0.5 | | $0.3DV_{DD}$ | V |
| V_{OS} | Maximum voltage during overshoot | | | 4.3^{\S} | V |
| V_{US} | Maximum voltage during undershoot | -1.0^{\S} | | | V |
| T_C | Operating case temperature | Default | | 90 | °C |
| | | A version [A-500 and A-600] | -40 | 105 | °C |

[‡] Future variants of the C64x DSPs may operate at voltages ranging from 0.9 V to 1.4 V to provide a range of system power/performance options. TI highly recommends that users design-in a supply that can handle multiple voltages within this range (i.e., 1.2 V, 1.25 V, 1.3 V, 1.35 V, 1.4 V with $\pm 3\%$ tolerances) by implementing simple board changes such as reference resistor values or input pin configuration modifications. Examples of such supplies include the PT4660, PT5500, PT5520, PT6440, and PT6930 series from Power Trends, a subsidiary of Texas Instruments. Not incorporating a flexible supply may limit the system’s ability to easily adapt to future versions of C64x devices.

[§] The absolute maximum ratings should *not* be exceeded for more than 30% of the cycle period.

3.3 Electrical Characteristics Over Recommended Ranges of Supply Voltage and Operating Case Temperature (Unless Otherwise Noted)

| PARAMETER | | TEST CONDITIONS† | MIN | TYP | MAX | UNIT |
|-----------|--|--|--------------------------|------|--------------------------|---------------|
| V_{OH} | High-level output voltage (except PCI) | $DV_{DD} = \text{MIN}$, $I_{OH} = \text{MAX}^*$ | 2.4 | | | V |
| V_{OHP} | High-level output voltage (PCI) | $I_{OHP} = -0.5 \text{ mA}$, $DV_{DD} = 3.3 \text{ V}$ | $0.9DV_{DD}^{\parallel}$ | | | V |
| V_{OL} | Low-level output voltage (except PCI) | $DV_{DD} = \text{MIN}$, $I_{OL} = \text{MAX}^*$ | | | 0.4 | V |
| V_{OLP} | Low-level output voltage (PCI) | $I_{OLP} = 1.5 \text{ mA}$, $DV_{DD} = 3.3 \text{ V}$ | | | $0.1DV_{DD}^{\parallel}$ | V |
| I_I | Input current (except PCI) | $V_I = V_{SS}$ to DV_{DD} no opposing internal resistor | | | ± 10 | μA |
| | | $V_I = V_{SS}$ to DV_{DD} opposing internal pullup resistor‡ | 50 | 100 | 150 | μA |
| | | $V_I = V_{SS}$ to DV_{DD} opposing internal pulldown resistor‡ | -150 | -100 | -50 | μA |
| I_{IP} | Input leakage current (PCI)§ | $0 < V_{IP} < DV_{DD} = 3.3 \text{ V}$ | | | ± 10 | μA |
| I_{OH} | High-level output current | EMIF, CLKOUT4, CLKOUT6, EMUx | | | -16 | mA |
| | | Timer, TDO, GPIO (Excluding GP0[15:9, 2, 1]), McBSP | | | -8 | mA |
| | | PCI/HPI | | | -0.5^{\parallel} | mA |
| I_{OL} | Low-level output current | EMIF, CLKOUT4, CLKOUT6, EMUx | | | 16 | mA |
| | | Timer, TDO, GPIO (Excluding GP0[15:9, 2, 1]), McBSP | | | 8 | mA |
| | | SCL0 and SDA0 | | | 3 | mA |
| | | PCI/HPI | | | 1.5^{\parallel} | mA |
| I_{OZ} | Off-state output current | $V_O = DV_{DD}$ or 0 V | | | ± 10 | μA |
| I_{CDD} | Core supply current# | $CV_{DD} = 1.4 \text{ V}$, CPU clock = 720 MHz | | 1090 | | mA |
| | | $CV_{DD} = 1.4 \text{ V}$, CPU clock = 600 MHz | | 890 | | mA |
| | | $CV_{DD} = 1.2 \text{ V}$, CPU clock = 500 MHz | | 620 | | mA |
| I_{DDD} | I/O supply current# | $DV_{DD} = 3.3 \text{ V}$, CPU clock = 720 MHz | | 210 | | mA |
| | | $DV_{DD} = 3.3 \text{ V}$, CPU clock = 600 MHz | | 210 | | mA |
| | | $DV_{DD} = 3.3 \text{ V}$, CPU clock = 500 MHz | | 165 | | mA |
| C_i | Input capacitance | | | | 10 | pF |
| C_o | Output capacitance | | | | 10 | pF |

† For test conditions shown as MIN, MAX, or NOM, use the appropriate value specified in the recommended operating conditions table.

‡ Applies only to pins with an internal pullup (IPU) or pulldown (IPD) resistor.

§ PCI input leakage currents include Hi-Z output leakage for all bidirectional buffers with 3-state outputs.

[¶] These rated numbers are from the PCI specification version 2.3. The DC specification and AC specification are defined in Tables 4-3 and 4-4, respectively.

Measured with average activity (50% high/50% low power) at 25°C case temperature and 133-MHz EMIF for -600 and -720 speeds (100-MHz EMIF for -500 speed). This model represents a device performing high-DSP-activity operations 50% of the time, and the remainder performing low-DSP-activity operations. The high/low-DSP-activity models are defined as follows:

High-DSP-Activity Model:

CPU: 8 instructions/cycle with 2 LDDW instructions [L1 Data Memory: 128 bits/cycle via LDDW instructions;
L1 Program Memory: 256 bits/cycle; L2/EMIF EDMA: 50% writes, 50% reads to/from SDRAM (50% bit-switching)]
McBSP: 2 channels at E1 rate
Timers: 2 timers at maximum rate

Low-DSP-Activity Model:

CPU: 2 instructions/cycle with 1 LDH instruction [L1 Data Memory: 16 bits/cycle; L1 Program Memory: 256 bits per 4 cycles;
L2/EMIF EDMA: None]
McBSP: 2 channels at E1 rate
Timers: 2 timers at maximum rate

The actual current draw is highly application-dependent. For more details on core and I/O activity, refer to the *TMS320C6412 Power Consumption Summary* application report (literature number SPRA967).

* Single pin driving $I_{OH}/I_{OL} = \text{MAX}$.

3.4 Recommended Clock and Control Signal Transition Behavior

All clocks and control signals **must** transition between V_{IH} and V_{IL} (or between V_{IL} and V_{IH}) in a monotonic manner.

4 Parameter Information

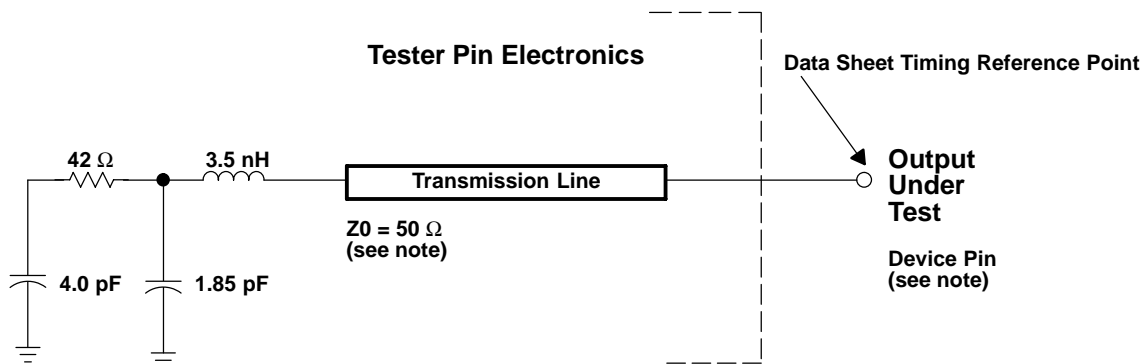

NOTE: The data sheet provides timing at the device pin. For output timing analysis, the tester pin electronics and its transmission line effects must be taken into account. A transmission line with a delay of 2 ns or longer can be used to produce the desired transmission line effect. The transmission line is intended as a load only. It is not necessary to add or subtract the transmission line delay (2 ns or longer) from the data sheet timings.

Input requirements in this data sheet are tested with an input slew rate of < 4 Volts per nanosecond (4 V/ns) at the device pin.

Figure 4-1. Test Load Circuit for AC Timing Measurements

The load capacitance value stated is only for characterization and measurement of AC timing signals. This load capacitance value does not indicate the maximum load the device is capable of driving.

4.1 Signal Transition Levels

All input and output timing parameters are referenced to 1.5 V for both “0” and “1” logic levels.

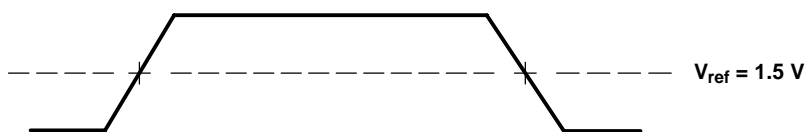

Figure 4-2. Input and Output Voltage Reference Levels for AC Timing Measurements

All rise and fall transition timing parameters are referenced to V_{IL} MAX and V_{IH} MIN for input clocks, V_{OL} MAX and V_{OH} MIN for output clocks, V_{ILP} MAX and V_{IHP} MIN for PCI input clocks, and V_{OLP} MAX and V_{OHP} MIN for PCI output clocks.

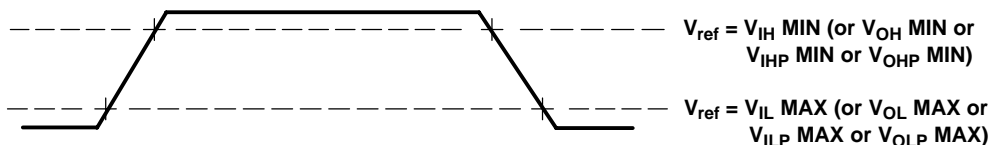

Figure 4-3. Rise and Fall Transition Time Voltage Reference Levels

4.2 Signal Transition Rates

All timings are tested with an input edge rate of 4 Volts per nanosecond (4 V/ns).

4.2.1 AC Transient Rise/fall Time Specifications

Figure 4–4 and Figure 4–5 show the AC transient specifications for Rise and Fall Time. For device-specific information on these values, refer to the Recommended Operating Conditions section of this Data Sheet.

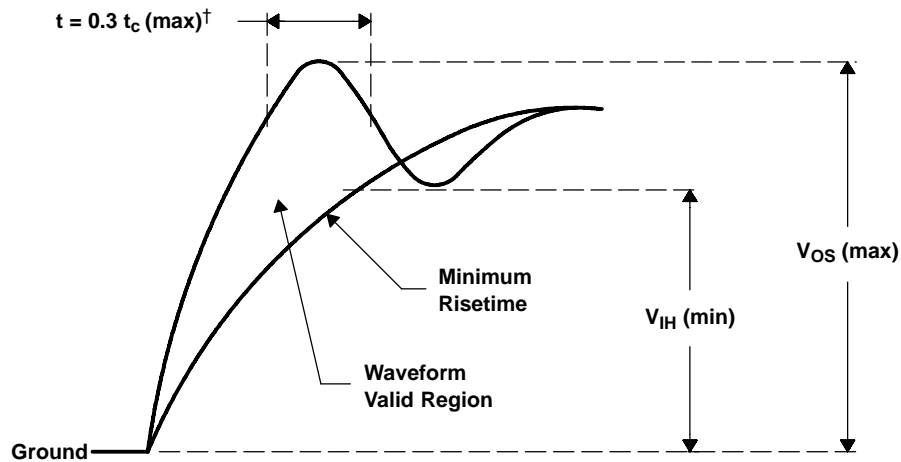

Figure 4–4. AC Transient Specification Rise Time

$^\dagger t_c$ = the peripheral cycle time in nanoseconds (ns).

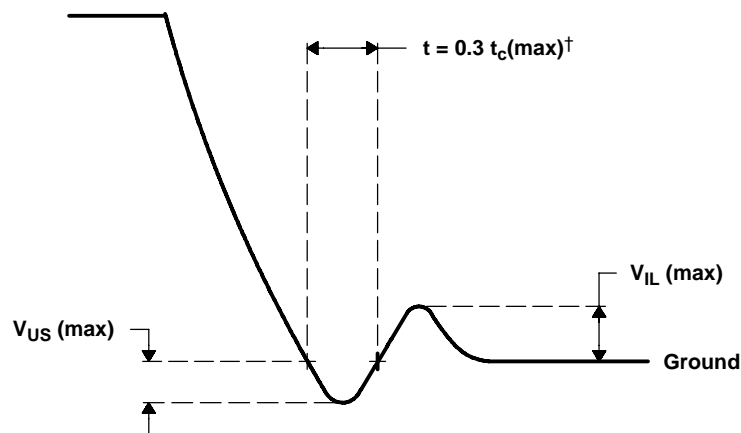

Figure 4–5. AC Transient Specification Fall Time

† t_c = the peripheral cycle time in nanoseconds (ns).

4.3 Timing Parameters and Board Routing Analysis

The timing parameter values specified in this data sheet do *not* include delays by board routings. As a good board design practice, such delays must *always* be taken into account. Timing values may be adjusted by increasing/decreasing such delays. TI recommends utilizing the available I/O buffer information specification (IBIS) models to analyze the timing characteristics correctly. To properly use IBIS models to attain accurate timing analysis for a given system, see the *Using IBIS Models for Timing Analysis* application report (literature number SPRA839). If needed, external logic hardware such as buffers may be used to compensate for any timing differences.

For inputs, timing is most impacted by the round-trip propagation delay from the DSP to the external device and from the external device to the DSP. This round-trip delay tends to negatively impact the input setup time margin, but also tends to improve the input hold time margins (see Table 4–1 and Figure 4–6).

Figure 4–6 represents a general transfer between the DSP and an external device. The figure also represents board route delays and how they are perceived by the DSP and the external device.

Table 4–1. Board-Level Timing Example (see Figure 4–6)

| NO. | DESCRIPTION |
|-----|--|
| 1 | Clock route delay |
| 2 | Minimum DSP hold time |
| 3 | Minimum DSP setup time |
| 4 | External device hold time requirement |
| 5 | External device setup time requirement |
| 6 | Control signal route delay |
| 7 | External device hold time |
| 8 | External device access time |
| 9 | DSP hold time requirement |
| 10 | DSP setup time requirement |
| 11 | Data route delay |

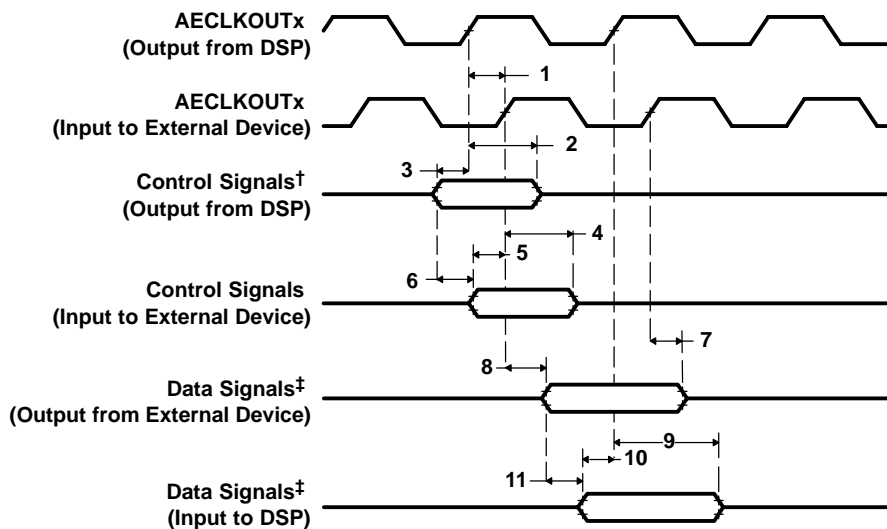

† Control signals include data for Writes.

‡ Data signals are generated during Reads from an external device.

Figure 4–6. Board-Level Input/Output Timings

4.4 Input and Output Clocks

Table 4–2. Timing Requirements for CLKIN for –500 Devices^{†‡§} (see Figure 4–7)

| NO. | | –500 | | | | | | UNIT |
|-----|--|--------------|------|-------------|------|-------------|------|------|
| | | PLL MODE x12 | | PLL MODE x6 | | x1 (BYPASS) | | |
| | | MIN | MAX | MIN | MAX | MIN | MAX | |
| 1 | $t_{c(CLKIN)}$ Cycle time, CLKIN | 24 | 33.3 | 13.3 | 33.3 | 13.3 | 33.3 | ns |
| 2 | $t_{w(CLKINH)}$ Pulse duration, CLKIN high | 0.45C | | 0.45C | | 0.45C | | ns |
| 3 | $t_{w(CLKINL)}$ Pulse duration, CLKIN low | 0.45C | | 0.45C | | 0.45C | | ns |
| 4 | $t_{t(CLKIN)}$ Transition time, CLKIN | 5 | | 5 | | 1 | | ns |
| 5 | $t_{j(CLKIN)}$ Period jitter, CLKIN | 0.02C | | 0.02C | | 0.02C | | ns |

[†] The reference points for the rise and fall transitions are measured at V_{IL} MAX and V_{IH} MIN.

[‡] For more details on the PLL multiplier factors (x6, x12), see the *Clock PLL* section of this data sheet.

[§] C = CLKIN cycle time in ns. For example, when CLKIN frequency is 50 MHz, use C = 20 ns.

Table 4–3. Timing Requirements for CLKIN for –600 Devices^{†‡§} (see Figure 4–7)

| NO. | | –600 | | | | | | UNIT |
|-----|--|--------------|------|-------------|------|-------------|------|------|
| | | PLL MODE x12 | | PLL MODE x6 | | x1 (BYPASS) | | |
| | | MIN | MAX | MIN | MAX | MIN | MAX | |
| 1 | $t_{c(CLKIN)}$ Cycle time, CLKIN | 20 | 33.3 | 13.3 | 33.3 | 13.3 | 33.3 | ns |
| 2 | $t_{w(CLKINH)}$ Pulse duration, CLKIN high | 0.45C | | 0.45C | | 0.45C | | ns |
| 3 | $t_{w(CLKINL)}$ Pulse duration, CLKIN low | 0.45C | | 0.45C | | 0.45C | | ns |
| 4 | $t_{t(CLKIN)}$ Transition time, CLKIN | 5 | | 5 | | 1 | | ns |
| 5 | $t_{j(CLKIN)}$ Period jitter, CLKIN | 0.02C | | 0.02C | | 0.02C | | ns |

[†] The reference points for the rise and fall transitions are measured at V_{IL} MAX and V_{IH} MIN.

[‡] For more details on the PLL multiplier factors (x6, x12), see the *Clock PLL* section of this data sheet.

[§] C = CLKIN cycle time in ns. For example, when CLKIN frequency is 50 MHz, use C = 20 ns.

Table 4–4. Timing Requirements for CLKIN for –720 Devices†‡§ (see Figure 4–7)

| NO. | | –720 | | | | | | UNIT | | |
|-----|----------------------|----------------------------|-----|-------------|------|-------------|------|-------|------|----|
| | | PLL MODE x12 | | PLL MODE x6 | | x1 (BYPASS) | | | | |
| | | MIN | MAX | MIN | MAX | MIN | MAX | | | |
| 1 | $t_c(\text{CLKIN})$ | Cycle time, CLKIN | | 16.6 | 33.3 | 13.3 | 33.3 | 13.3 | 33.3 | ns |
| 2 | $t_w(\text{CLKINH})$ | Pulse duration, CLKIN high | | 0.45C | | 0.45C | | 0.45C | | ns |
| 3 | $t_w(\text{CLKINL})$ | Pulse duration, CLKIN low | | 0.45C | | 0.45C | | 0.45C | | ns |
| 4 | $t_t(\text{CLKIN})$ | Transition time, CLKIN | | 5 | | 5 | | 1 | | ns |
| 5 | $t_j(\text{CLKIN})$ | Period jitter, CLKIN | | 0.02C | | 0.02C | | 0.02C | | ns |

† The reference points for the rise and fall transitions are measured at $V_{IL \text{ MAX}}$ and $V_{IH \text{ MIN}}$.

‡ For more details on the PLL multiplier factors (x6, x12), see the *Clock PLL* section of this data sheet.

§ C = CLKIN cycle time in ns. For example, when CLKIN frequency is 50 MHz, use C = 20 ns.

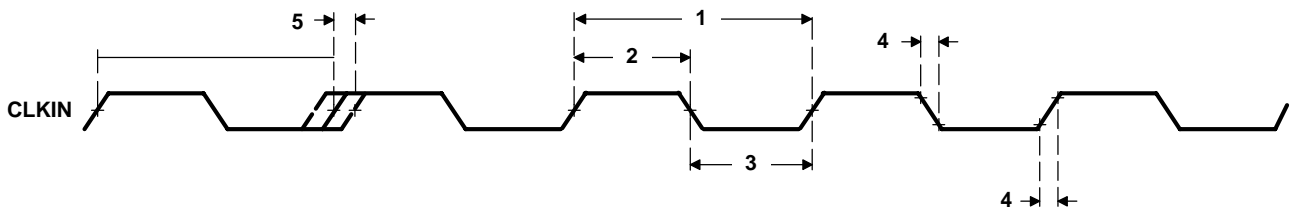

Figure 4–7. CLKIN Timing

Table 4–5. Switching Characteristics Over Recommended Operating Conditions for CLKOUT4†‡§ (see Figure 4–8)

| NO. | PARAMETER | –500 –600 –720 | | UNIT | | |
|-----|---------------------|------------------------------|-----|------------|------------|----|
| | | CLKMODE = x1, x6, x12 | | | | |
| | | MIN | MAX | | | |
| 1 | $t_w(\text{CKO4H})$ | Pulse duration, CLKOUT4 high | | $2P - 0.7$ | $2P + 0.7$ | ns |
| 2 | $t_w(\text{CKO4L})$ | Pulse duration, CLKOUT4 low | | $2P - 0.7$ | $2P + 0.7$ | ns |
| 3 | $t_t(\text{CKO4})$ | Transition time, CLKOUT4 | | 1 | | ns |

† The reference points for the rise and fall transitions are measured at $V_{OL \text{ MAX}}$ and $V_{OH \text{ MIN}}$.

‡ PH is the high period of CLKIN in ns and PL is the low period of CLKIN in ns.

§ P = 1/CPU clock frequency in nanoseconds (ns)

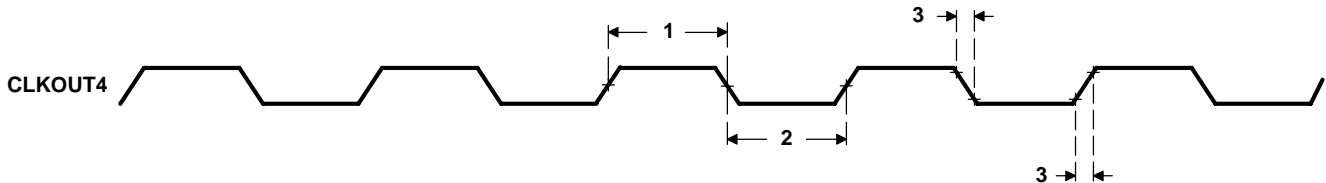

Figure 4–8. CLKOUT4 Timing

Table 4–6. Switching Characteristics Over Recommended Operating Conditions for CLKOUT6†‡§
(see Figure 4–9)

| NO. | PARAMETER | –500 –600 –720 | | UNIT |
|-----|---|-----------------------|------------|------|
| | | CLKMODE = x1, x6, x12 | | |
| | | MIN | MAX | |
| 1 | $t_{w(CKO6H)}$ Pulse duration, CLKOUT6 high | $3P - 0.7$ | $3P + 0.7$ | ns |
| 2 | $t_{w(CKO6L)}$ Pulse duration, CLKOUT6 low | $3P - 0.7$ | $3P + 0.7$ | ns |
| 3 | $t_t(CKO6)$ Transition time, CLKOUT6 | 1 | | ns |

† The reference points for the rise and fall transitions are measured at $V_{OL\ MAX}$ and $V_{OH\ MIN}$.

‡ PH is the high period of CLKIN in ns and PL is the low period of CLKIN in ns.

§ P = 1/CPU clock frequency in nanoseconds (ns)

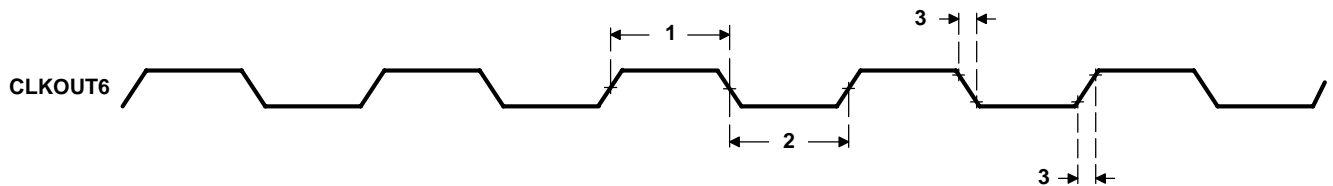

Figure 4–9. CLKOUT6 Timing

Table 4–7. Timing Requirements for AECLKIN for EMIFA†‡§ (see Figure 4–10)

| NO. | PARAMETER | -500 -600 -720 | | UNIT |
|-----|---|----------------------|-------|------|
| | | MIN | MAX | |
| 1 | $t_{c(EKI)}$ Cycle time, AECLKIN | 6 [¶] | 16P | ns |
| 2 | $t_{w(EKI H)}$ Pulse duration, AECLKIN high | 2.7 | | ns |
| 3 | $t_{w(EKI L)}$ Pulse duration, AECLKIN low | 2.7 | | ns |
| 4 | $t_t(EKI)$ Transition time, AECLKIN | | 3 | ns |
| 5 | $t_{j(EKI)}$ Period jitter, AECLKIN | | 0.02E | ns |

† P = 1/CPU clock frequency in ns. For example, when running parts at 600 MHz, use P = 1.67 ns.

‡ The reference points for the rise and fall transitions are measured at V_{IL} MAX and V_{IH} MIN.

§ E = the EMIF input clock (AECLKIN, CPU/4 clock, or CPU/6 clock) period in ns for EMIFA.

¶ Minimum AECLKIN cycle times *must* be met, even when AECLKIN is generated by an internal clock source. Minimum AECLKIN times are based on internal logic speed; the maximum useable speed of the EMIF may be lower due to AC timing requirements. On the 600 devices, 133-MHz operation is achievable if the requirements of the EMIF Device Speed section are met. On the 500 devices, 100-MHz operation is achievable if the requirements of the EMIF Device Speed section are met.

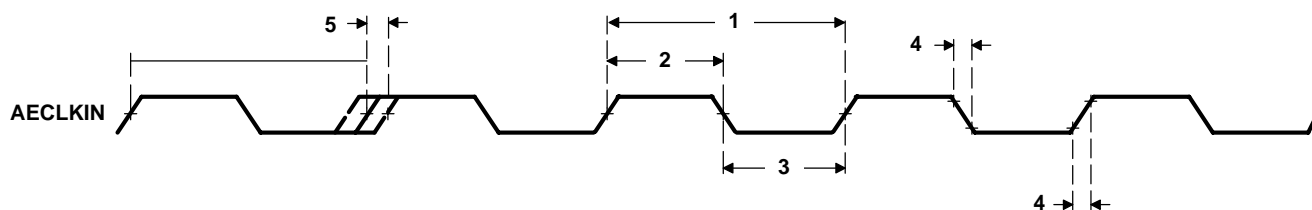

Figure 4–10. AECLKIN Timing for EMIFA

Table 4–8. Switching Characteristics Over Recommended Operating Conditions for AECLKOUT1 for the EMIFA Module†#|| (see Figure 4–11)

| NO. | PARAMETER | -500 -600 -720 | | UNIT |
|-----|--|----------------------|----------|------|
| | | MIN | MAX | |
| 1 | $t_{w(EKO1 H)}$ Pulse duration, AECLKOUT1 high | EH – 0.7 | EH + 0.7 | ns |
| 2 | $t_{w(EKO1 L)}$ Pulse duration, AECLKOUT1 low | EL – 0.7 | EL + 0.7 | ns |
| 3 | $t_t(EKO1)$ Transition time, AECLKOUT1 | | 1 | ns |
| 4 | $t_d(EKI H-EKO1 H)$ Delay time, AECLKIN high to AECLKOUT1 high | 1 | 8 | ns |
| 5 | $t_d(EKI L-EKO1 L)$ Delay time, AECLKIN low to AECLKOUT1 low | 1 | 8 | ns |

† The reference points for the rise and fall transitions are measured at V_{OL} MAX and V_{OH} MIN.

E = the EMIF input clock (AECLKIN, CPU/4 clock, or CPU/6 clock) period in ns for EMIFA.

|| EH is the high period of E (EMIF input clock period) in ns and EL is the low period of E (EMIF input clock period) in ns for EMIFA.

* This cycle-to-cycle jitter specification was measured with CPU/4 or CPU/6 as the source of the EMIF input clock.

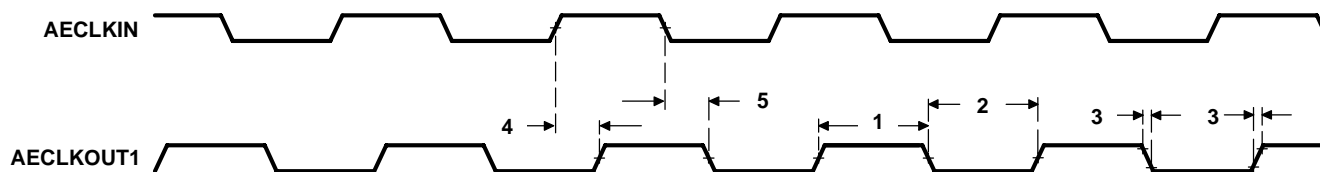

Figure 4–11. AECLKOUT1 Timing for EMIFA Module

Table 4–9. Switching Characteristics Over Recommended Operating Conditions for AECLKOUT2 for the EMIFA Module^{†‡} (see Figure 4–12)

| NO. | PARAMETER | –500 –600 –720 | | UNIT |
|-----|--|----------------------|---------------|------|
| | | MIN | MAX | |
| 1 | $t_{w(EKO2H)}$ Pulse duration, AECLKOUT2 high | $0.5NE - 0.7$ | $0.5NE + 0.7$ | ns |
| 2 | $t_{w(EKO2L)}$ Pulse duration, AECLKOUT2 low | $0.5NE - 0.7$ | $0.5NE + 0.7$ | ns |
| 3 | $t_t(EKO2)$ Transition time, AECLKOUT2 | | 1 | ns |
| 4 | $t_d(EKIH-EKO2H)$ Delay time, AECLKIN high to AECLKOUT2 high | 1 | 8 | ns |
| 5 | $t_d(EKIL-EKO2L)$ Delay time, AECLKIN low to AECLKOUT2 low | 1 | 8 | ns |

[†] The reference points for the rise and fall transitions are measured at $V_{OL\ MAX}$ and $V_{OH\ MIN}$.

[‡] E = the EMIF input clock (AECLKIN, CPU/4 clock, or CPU/6 clock) period in ns for EMIFA.

N = the EMIF input clock divider; N = 1, 2, or 4.

[§] This cycle-to-cycle jitter specification was measured with CPU/4 or CPU/6 as the source of the EMIF input clock.

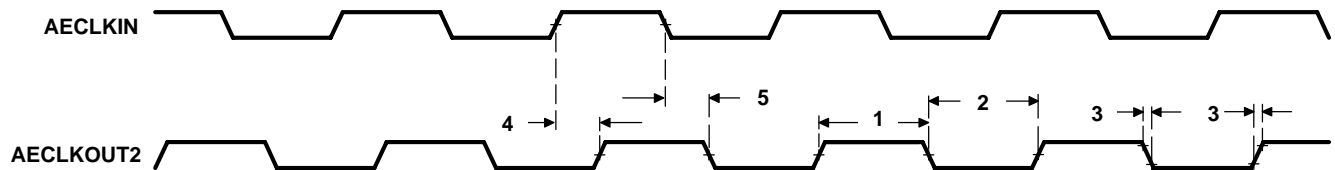
**Figure 4–12. AECLKOUT2 Timing for the EMIFA Module**

5 Asynchronous Memory Timing

Table 5–1. Timing Requirements for Asynchronous Memory Cycles for EMIFA Module^{†‡}
(see Figure 5–1 and Figure 5–2)

| NO. | | | -500 -600 -720 | | UNIT |
|-----|----------------------|--|----------------------|-----|------|
| | | | MIN | MAX | |
| 3 | $t_{su}(EDV-AREH)$ | Setup time, AEDx valid before \overline{AARE} high | 6.5 | | ns |
| 4 | $t_h(AREH-EDV)$ | Hold time, AEDx valid after \overline{AARE} high | 1 | | ns |
| 6 | $t_{su}(ARDY-EKO1H)$ | Setup time, AARDY valid before AECLKOUTx high | 3 | | ns |
| 7 | $t_h(EKO1H-ARDY)$ | Hold time, AARDY valid after AECLKOUTx high | 2.5 | | ns |

[†] To ensure data setup time, simply program the strobe width wide enough. AARDY is internally synchronized. The AARDY signal is *only* recognized two cycles before the end of the programmed strobe time and while AARDY is low, the strobe time is extended cycle-by-cycle. When AARDY is recognized low, the end of the strobe time is two cycles after AARDY is recognized high. To use AARDY as an asynchronous input, the pulse width of the AARDY signal should be wide enough (e.g., pulse width = 2E) to ensure setup and hold time is met.

[‡] RS = Read setup, RST = Read strobe, RH = Read hold, WS = Write setup, WST = Write strobe, WH = Write hold. These parameters are programmed via the EMIF CE space control registers.

Table 5–2. Switching Characteristics Over Recommended Operating Conditions for Asynchronous Memory Cycles for EMIFA Module^{†§¶} (see Figure 5–1 and Figure 5–2)

| NO. | PARAMETER | -500 -600 -720 | | UNIT |
|-----|----------------------|--|--------------|------|
| | | MIN | MAX | |
| 1 | $t_{osu}(SELV-AREL)$ | Output setup time, select signals valid to \overline{AARE} low | RS * E – 1.8 | ns |
| 2 | $t_{oh}(AREH-SELIV)$ | Output hold time, \overline{AARE} high to select signals invalid | RH * E – 1.9 | ns |
| 5 | $t_d(EKO1H-AREV)$ | Delay time, AECLKOUTx high to \overline{AARE} valid | 1 7 | ns |
| 8 | $t_{osu}(SELV-AWEL)$ | Output setup time, select signals valid to \overline{AAWE} low | WS * E – 2.0 | ns |
| 9 | $t_{oh}(AWEH-SELIV)$ | Output hold time, \overline{AAWE} high to select signals invalid | WH * E – 2.5 | ns |
| 10 | $t_d(EKO1H-AWEV)$ | Delay time, AECLKOUTx high to \overline{AAWE} valid | 1.3 7.1 | ns |

[†] RS = Read setup, RST = Read strobe, RH = Read hold, WS = Write setup, WST = Write strobe, WH = Write hold. These parameters are programmed via the EMIF CE space control registers.

[§] E = AECLKOUT1 period in ns for EMIFA

[¶] Select signals for EMIFA include: $\overline{ACE}x$, $\overline{ABE}[7:0]$, $\overline{AEA}[22:3]$, \overline{AAOE} ; and for EMIFA writes, include AED[63:0].

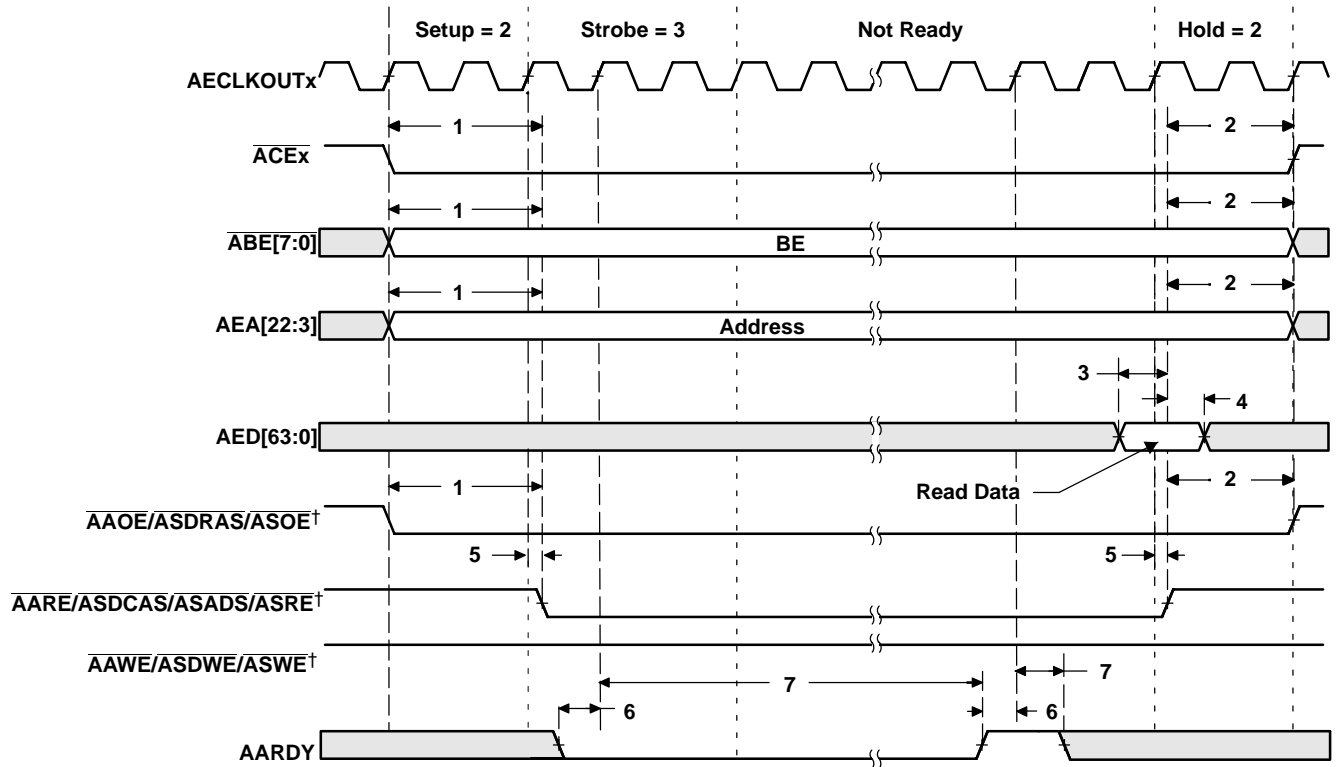

† AAOE/ASDRAS/ASOE, AARE/ASDCAS/ASADS/ASRE, and AAWE/ASDWE/ASWE operate as AAOE (identified under select signals), AARE, and AAWE, respectively, during asynchronous memory accesses.

Figure 5–1. Asynchronous Memory Read Timing for EMIFA

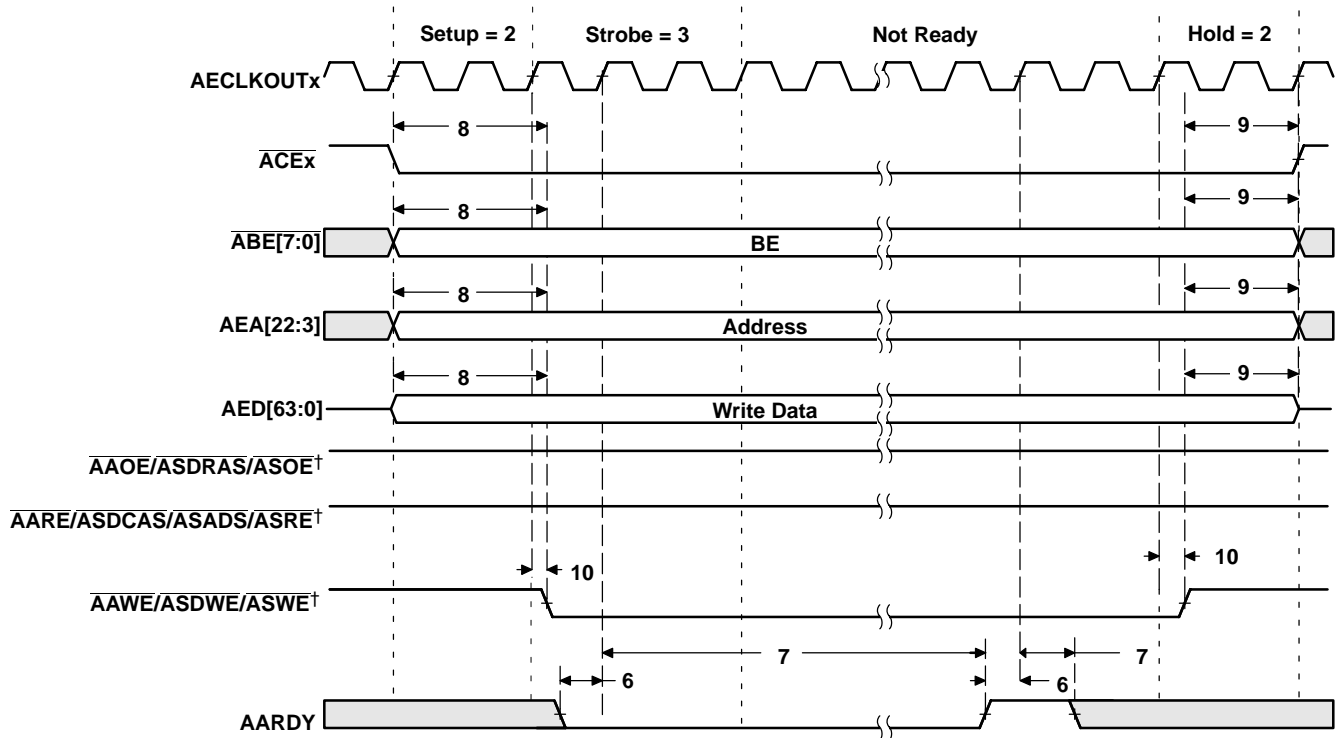

† AAOE/ASDRAS/ASOE, AARE/ASDCAS/ASADS/ASRE, and AAWE/ASDWE/ASWE operate as AAOE (identified under select signals), AARE, and AAWE, respectively, during asynchronous memory accesses.

Figure 5–2. Asynchronous Memory Write Timing for EMIFA

6 Programmable Synchronous Interface Timing

Table 6–1. Timing Requirements for Programmable Synchronous Interface Cycles for EMIFA Module† (see Figure 6–1)

| NO. | | –500 | | –600 –720 | | UNIT |
|-----|---|------|-----|--------------|-----|------|
| | | MIN | MAX | MIN | MAX | |
| 6 | $t_{su}(EDV-EKOxH)$ Setup time, read AEDx valid before AECLKOUTx high | 3.1 | | 2 | | ns |
| 7 | $t_h(EKOxH-EDV)$ Hold time, read AEDx valid after AECLKOUTx high | 1.8 | | 1.5 | | ns |

Table 6–2. Switching Characteristics Over Recommended Operating Conditions for Programmable Synchronous Interface Cycles for EMIFA Module† (see Figure 6–1–Figure 6–3)

| NO. | PARAMETER | –500 | | –600 –720 | | UNIT |
|-----|--|------|-----|--------------|-----|------|
| | | MIN | MAX | MIN | MAX | |
| 1 | $t_d(EKOxH-CEV)$ Delay time, AECLKOUTx high to \overline{ACEX} valid | 1.1 | 6.4 | 1.1 | 4.9 | ns |
| 2 | $t_d(EKOxH-BEV)$ Delay time, AECLKOUTx high to \overline{ABEX} valid | | 6.4 | | 4.9 | ns |
| 3 | $t_d(EKOxH-BEIV)$ Delay time, AECLKOUTx high to \overline{ABEX} invalid | 1.1 | | 1.1 | | ns |
| 4 | $t_d(EKOxH-EAV)$ Delay time, AECLKOUTx high to AEAx valid | | 6.4 | | 4.9 | ns |
| 5 | $t_d(EKOxH-EAIV)$ Delay time, AECLKOUTx high to AEAx invalid | 1.1 | | 1.1 | | ns |
| 8 | $t_d(EKOxH-ADSV)$ Delay time, AECLKOUTx high to $\overline{ASADS}/\overline{ASRE}$ valid | 1.1 | 6.4 | 1.1 | 4.9 | ns |
| 9 | $t_d(EKOxH-OEV)$ Delay time, AECLKOUTx high to \overline{ASOE} valid | 1.1 | 6.4 | 1.1 | 4.9 | ns |
| 10 | $t_d(EKOxH-EDV)$ Delay time, AECLKOUTx high to AEDx valid | | 6.4 | | 4.9 | ns |
| 11 | $t_d(EKOxH-EDIV)$ Delay time, AECLKOUTx high to AEDx invalid | 1.1 | | 1.1 | | ns |
| 12 | $t_d(EKOxH-WEV)$ Delay time, AECLKOUTx high to \overline{ASWE} valid | 1.1 | 6.4 | 1.1 | 4.9 | ns |

† The following parameters are programmable via the EMIF CE Space Secondary Control register (CEXSEC):

- Read latency (SYNCRL): 0-, 1-, 2-, or 3-cycle read latency
- Write latency (SYNCWL): 0-, 1-, 2-, or 3-cycle write latency
- \overline{ACEX} assertion length (CEEXT): For standard SBSRAM or ZBT SRAM interface, \overline{ACEX} goes inactive after the final command has been issued (CEEXT = 0). For synchronous FIFO interface with glue, \overline{ACEX} is active when \overline{ASOE} is active (CEEXT = 1).
- Function of $\overline{ASADS}/\overline{ASRE}$ (RENEN): For standard SBSRAM or ZBT SRAM interface, $\overline{ASADS}/\overline{ASRE}$ acts as \overline{ASADS} with deselect cycles (RENEN = 0). For FIFO interface, $\overline{ASADS}/\overline{ASRE}$ acts as \overline{ASRE} with NO deselect cycles (RENEN = 1).
- Synchronization clock (SNCCCLK): Synchronized to AECLKOUT1 or AECLKOUT2

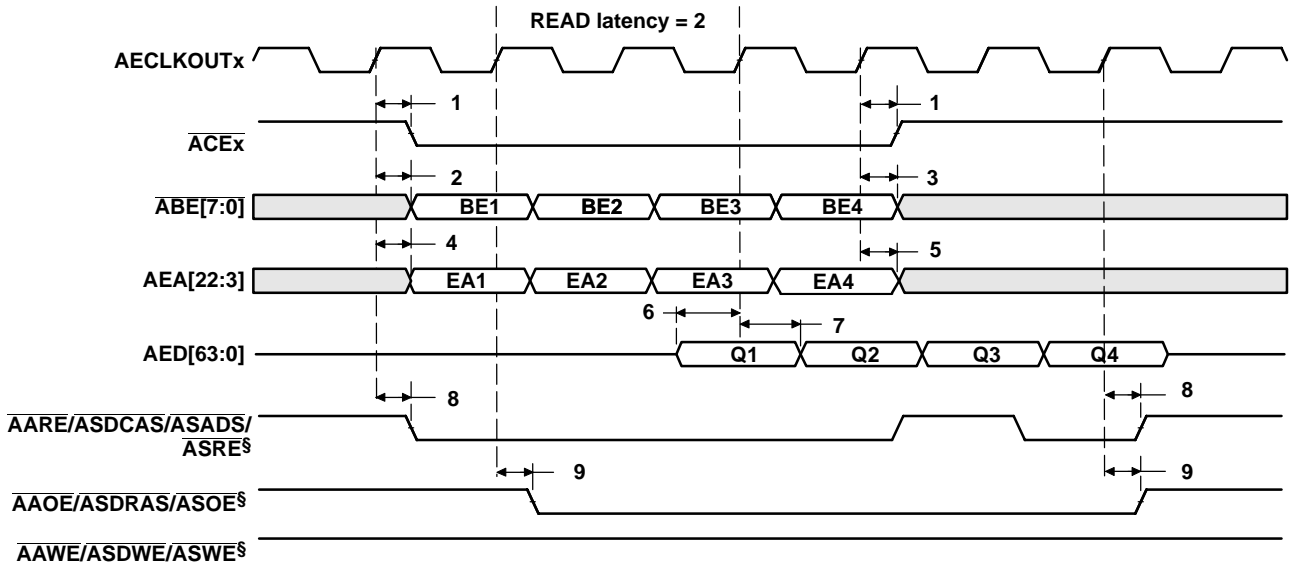

† The read latency and the length of \overline{ACEx} assertion are programmable via the SYNCRL and CEEXT fields, respectively, in the EMIFA CE Space Secondary Control register (CEXSEC). In this figure, SYNCRL = 2 and CEEXT = 0.

‡ The following parameters are programmable via the EMIF CE Space Secondary Control register (CEXSEC):

- Read latency (SYNCRL): 0-, 1-, 2-, or 3-cycle read latency
- Write latency (SYNCWL): 0-, 1-, 2-, or 3-cycle write latency
- \overline{ACEx} assertion length (CEEXT): For standard SBSRAM or ZBT SRAM interface, \overline{ACEx} goes inactive after the final command has been issued (CEEXT = 0). For synchronous FIFO interface with glue, \overline{ACEx} is active when \overline{ASOE} is active (CEEXT = 1).
- Function of $\overline{ASADS}/\overline{ASRE}$ (RENEN): For standard SBSRAM or ZBT SRAM interface, $\overline{ASADS}/\overline{ASRE}$ acts as \overline{ASADS} with deselect cycles (RENEN = 0). For FIFO interface, $\overline{ASADS}/\overline{ASRE}$ acts as \overline{ASRE} with NO deselect cycles (RENEN = 1).
- Synchronization clock (SNCLK): Synchronized to AECLKOUT1 or AECLKOUT2

§ $\overline{AARE}/\overline{ASDCAS}/\overline{ASADS}/\overline{ASRE}$, $\overline{AAOE}/\overline{ASDRAS}/\overline{ASOE}$, and $\overline{AAWE}/\overline{ASDWE}/\overline{ASWE}$ operate as $\overline{ASADS}/\overline{ASRE}$, \overline{ASOE} , and \overline{ASWE} , respectively, during programmable synchronous interface accesses.

**Figure 6–1. Programmable Synchronous Interface Read Timing for EMIFA
(With Read Latency = 2)†‡**

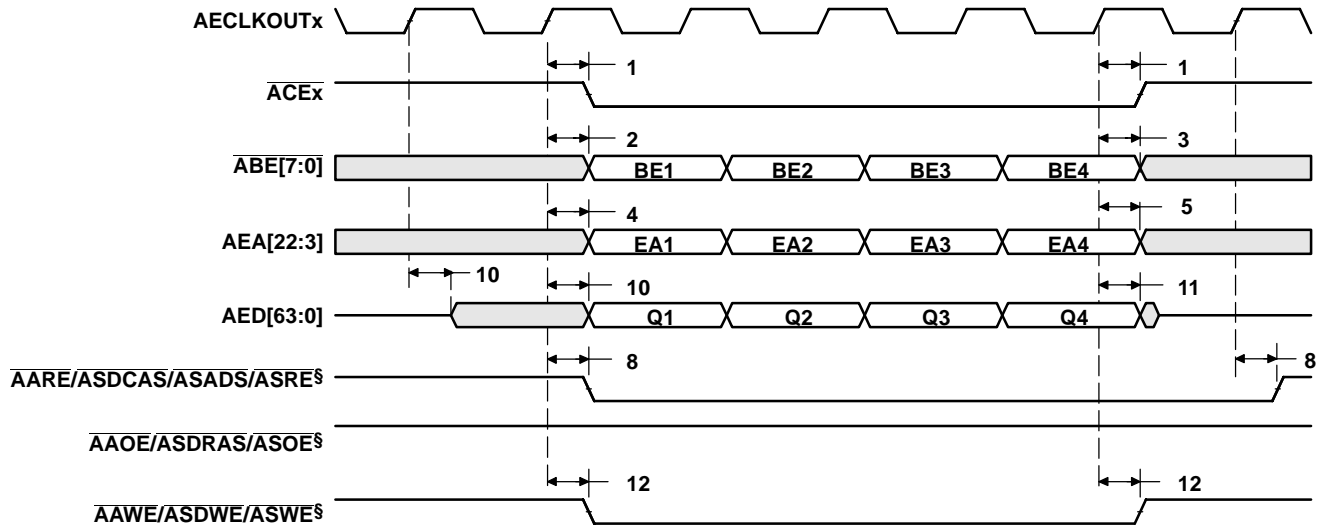

† The write latency and the length of \overline{ACEx} assertion are programmable via the SYNCWL and CEEXT fields, respectively, in the EMIFA CE Space Secondary Control register (CEXSEC). In this figure, SYNCWL = 0 and CEEXT = 0.

‡ The following parameters are programmable via the EMIF CE Space Secondary Control register (CEXSEC):

- Read latency (SYNCRL): 0-, 1-, 2-, or 3-cycle read latency
- Write latency (SYNCWL): 0-, 1-, 2-, or 3-cycle write latency
- \overline{ACEx} assertion length (CEEXT): For standard SBSRAM or ZBT SRAM interface, \overline{ACEx} goes inactive after the final command has been issued (CEEXT = 0). For synchronous FIFO interface with glue, \overline{ACEx} is active when \overline{ASOE} is active (CEEXT = 1).
- Function of $\overline{ASADS}/\overline{ASRE}$ (RENEN): For standard SBSRAM or ZBT SRAM interface, $\overline{ASADS}/\overline{ASRE}$ acts as \overline{ASADS} with deselect cycles (RENEN = 0). For FIFO interface, $\overline{ASADS}/\overline{ASRE}$ acts as \overline{ASRE} with NO deselect cycles (RENEN = 1).
- Synchronization clock (SNCLK): Synchronized to AECLKOUT1 or AECLKOUT2

§ $\overline{AARE}/\overline{ASDCAS}/\overline{ASADS}/\overline{ASRE}$, $\overline{AAOE}/\overline{ASDRAS}/\overline{ASOE}$, and $\overline{AAWE}/\overline{ASDWE}/\overline{ASWE}$ operate as $\overline{ASADS}/\overline{ASRE}$, \overline{ASOE} , and \overline{ASWE} , respectively, during programmable synchronous interface accesses.

**Figure 6–2. Programmable Synchronous Interface Write Timing for EMIFA
(With Write Latency = 0)†‡§**

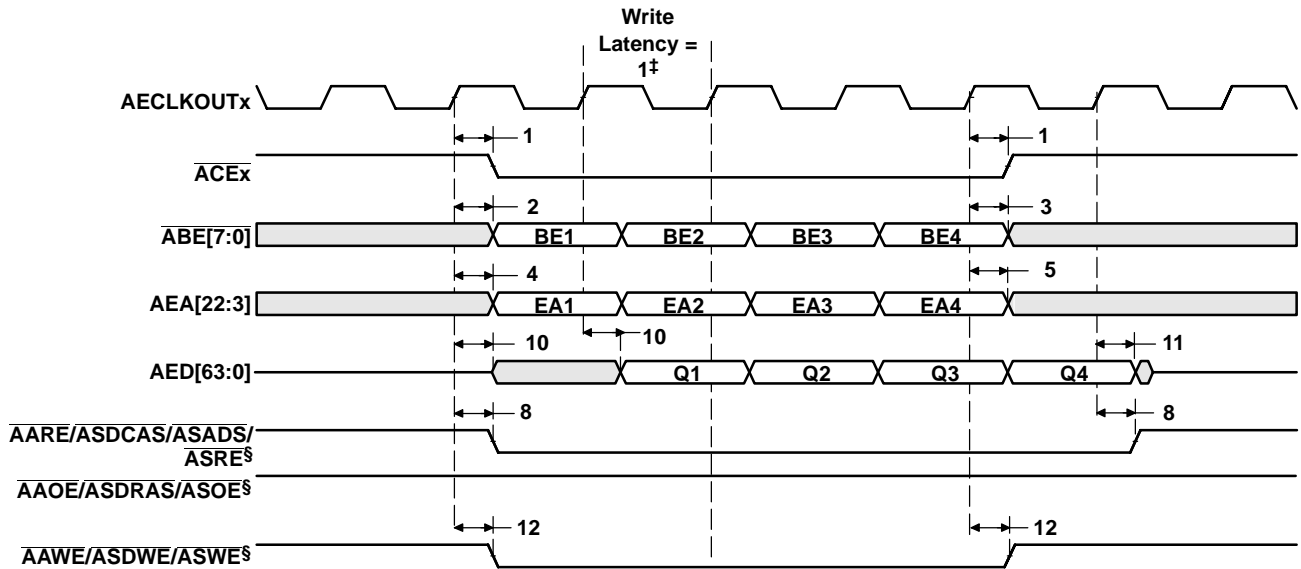

† The write latency and the length of \overline{ACEx} assertion are programmable via the SYNCWL and CEEXT fields, respectively, in the EMIFA CE Space Secondary Control register (CEXSEC). In this figure, SYNCWL = 1 and CEEXT = 0.

‡ The following parameters are programmable via the EMIF CE Space Secondary Control register (CEXSEC):

- Read latency (SYNCRL): 0-, 1-, 2-, or 3-cycle read latency
- Write latency (SYNCWL): 0-, 1-, 2-, or 3-cycle write latency
- \overline{ACEx} assertion length (CEEXT): For standard SBSRAM or ZBT SRAM interface, \overline{ACEx} goes inactive after the final command has been issued (CEEXT = 0). For synchronous FIFO interface with glue, \overline{ACEx} is active when \overline{ASOE} is active (CEEXT = 1).
- Function of $\overline{ASADS}/\overline{ASRE}$ (RENEN): For standard SBSRAM or ZBT SRAM interface, $\overline{ASADS}/\overline{ASRE}$ acts as \overline{ASADS} with deselect cycles (RENEN = 0). For FIFO interface, $\overline{ASADS}/\overline{ASRE}$ acts as \overline{ASRE} with NO deselect cycles (RENEN = 1).
- Synchronization clock (SNCLK): Synchronized to AECLKOUT1 or AECLKOUT2

§ $\overline{AARE}/\overline{ASDCAS}/\overline{ASADS}/\overline{ASRE}$, $\overline{AAOE}/\overline{ASDRAS}/\overline{ASOE}$, and $\overline{AAWE}/\overline{ASDWE}/\overline{ASWE}$ operate as $\overline{ASADS}/\overline{ASRE}$, \overline{AsOE} , and \overline{ASWE} , respectively, during programmable synchronous interface accesses.

Figure 6–3. Programmable Synchronous Interface Write Timing for EMIFA (With Write Latency = 1)†‡

7 Synchronous DRAM Timing

Table 7-1. Timing Requirements for Synchronous DRAM Cycles for EMIFA Module (see Figure 7-1)

| NO. | | -500 | | -600 -720 | | UNIT |
|-----|---|------|-----|--------------|-----|------|
| | | MIN | MAX | MIN | MAX | |
| 6 | $t_{su}(EDV-EK01H)$ Setup time, read AEDx valid before AECLKOUTx high | 2.1 | | 0.6 | | ns |
| 7 | $t_h(EK01H-EDV)$ Hold time, read AEDx valid after AECLKOUTx high | 2.8 | | 2.1 | | ns |

Table 7-2. Switching Characteristics Over Recommended Operating Conditions for Synchronous DRAM Cycles for EMIFA Module (see Figure 7-1–Figure 7-8)

| NO. | PARAMETER | -500 | | -600 -720 | | UNIT |
|-----|---|------|-----|--------------|-----|------|
| | | MIN | MAX | MIN | MAX | |
| 1 | $t_d(EK01H-CEV)$ Delay time, AECLKOUTx high to \overline{ACEx} valid | 1.3 | 6.4 | 1.3 | 4.9 | ns |
| 2 | $t_d(EK01H-BEV)$ Delay time, AECLKOUTx high to \overline{ABEx} valid | | 6.4 | | 4.9 | ns |
| 3 | $t_d(EK01H-BEIV)$ Delay time, AECLKOUTx high to \overline{ABEx} invalid | 1.3 | | 1.3 | | ns |
| 4 | $t_d(EK01H-EAV)$ Delay time, AECLKOUTx high to AEAx valid | | 6.4 | | 4.9 | ns |
| 5 | $t_d(EK01H-EAIV)$ Delay time, AECLKOUTx high to AEAx invalid | 1.3 | | 1.3 | | ns |
| 8 | $t_d(EK01H-CASV)$ Delay time, AECLKOUTx high to \overline{ASDCAS} valid | 1.3 | 6.4 | 1.3 | 4.9 | ns |
| 9 | $t_d(EK01H-EDV)$ Delay time, AECLKOUTx high to AEDx valid | | 6.4 | | 4.9 | ns |
| 10 | $t_d(EK01H-EDIV)$ Delay time, AECLKOUTx high to AEDx invalid | 1.3 | | 1.3 | | ns |
| 11 | $t_d(EK01H-WEV)$ Delay time, AECLKOUTx high to \overline{ASDWE} valid | 1.3 | 6.4 | 1.3 | 4.9 | ns |
| 12 | $t_d(EK01H-RAS)$ Delay time, AECLKOUTx high to \overline{ASDRAS} valid | 1.3 | 6.4 | 1.3 | 4.9 | ns |
| 13 | $t_d(EK01H-ACKEV)$ Delay time, AECLKOUTx high to ASDCKE valid | 1.3 | 6.4 | 1.3 | 4.9 | ns |
| 14 | $t_d(EK01H-PDTV)$ Delay time, AECLKOUTx high to \overline{APDT} valid | 1.3 | 6.4 | 1.3 | 4.9 | ns |

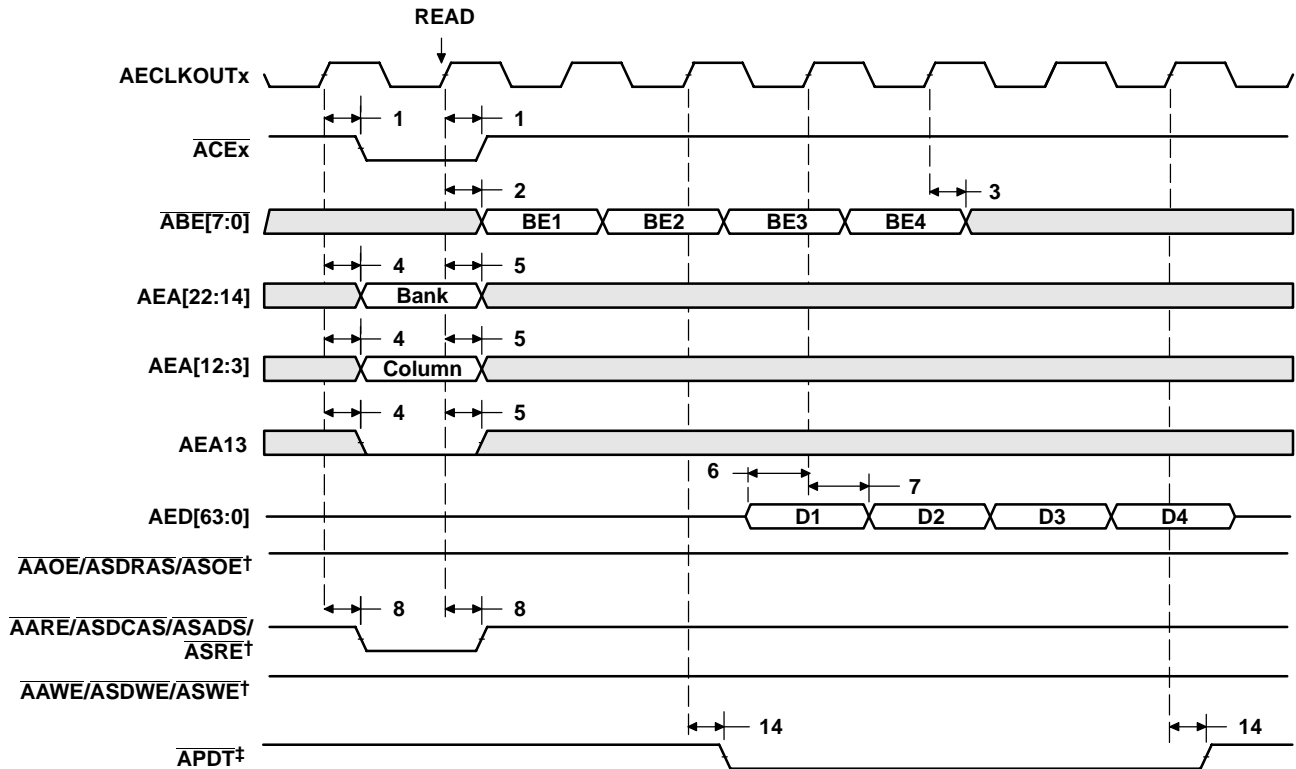

† AARE/ASDCAS/ASADS/ASRE, AAWE/ASDWE/ASWE, and AAOE/ASDRAS/ASOE operate as ASDCAS, ASDWE, and ASDRAS, respectively, during SDRAM accesses.

‡ APDT signal is only asserted when the EDMA is in PDT mode (set the PDTS bit to 1 in the EDMA options parameter RAM). For APDT read, data is not latched into EMIF. The PDTRL field in the PDT control register (PDTCTL) configures the latency of the APDT signal with respect to the data phase of a read transaction. The latency of the APDT signal for a read can be programmed to 0, 1, 2, or 3 by setting PDTRL to 00, 01, 10, or 11, respectively. PDTRL equals 00 (zero latency) in Figure 7–1.

Figure 7–1. SDRAM Read Command (CAS Latency 3) for EMIFA

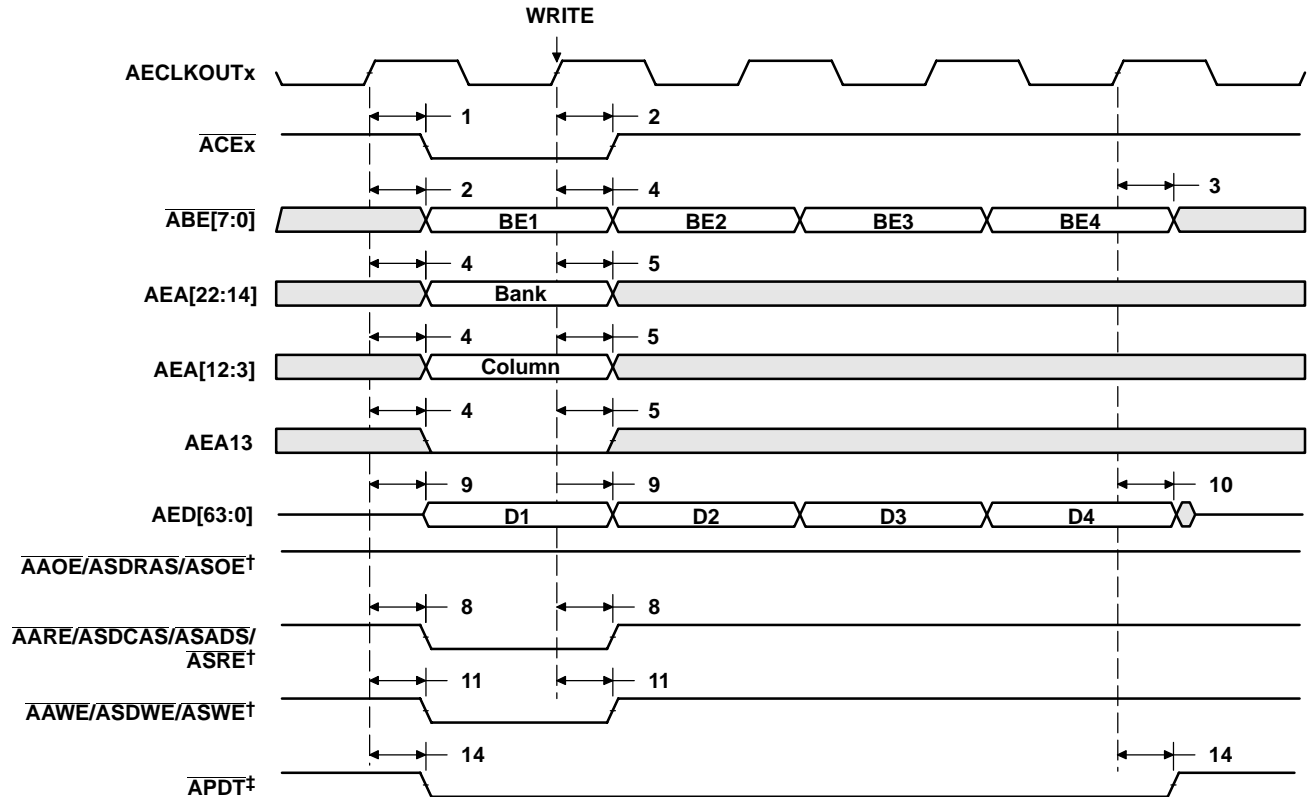

† AARE/ASDCAS/ASADS/ASRE, AAW/ASDWE/ASWE, and AAOE/ASDRAS/ASOE operate as ASDCAS, ASDWE, and ASDRAS, respectively, during SDRAM accesses.

‡ APDT signal is only asserted when the EDMA is in PDT mode (set the PDTD bit to 1 in the EDMA options parameter RAM). For APDT write, data is not driven (in High-Z). The PDTWL field in the PDT control register (PDTCTL) configures the latency of the APDT signal with respect to the data phase of a write transaction. The latency of the APDT signal for a write transaction can be programmed to 0, 1, 2, or 3 by setting PDTWL to 00, 01, 10, or 11, respectively. PDTWL equals 00 (zero latency) in Figure 7–2.

Figure 7–2. SDRAM Write Command for EMIFA

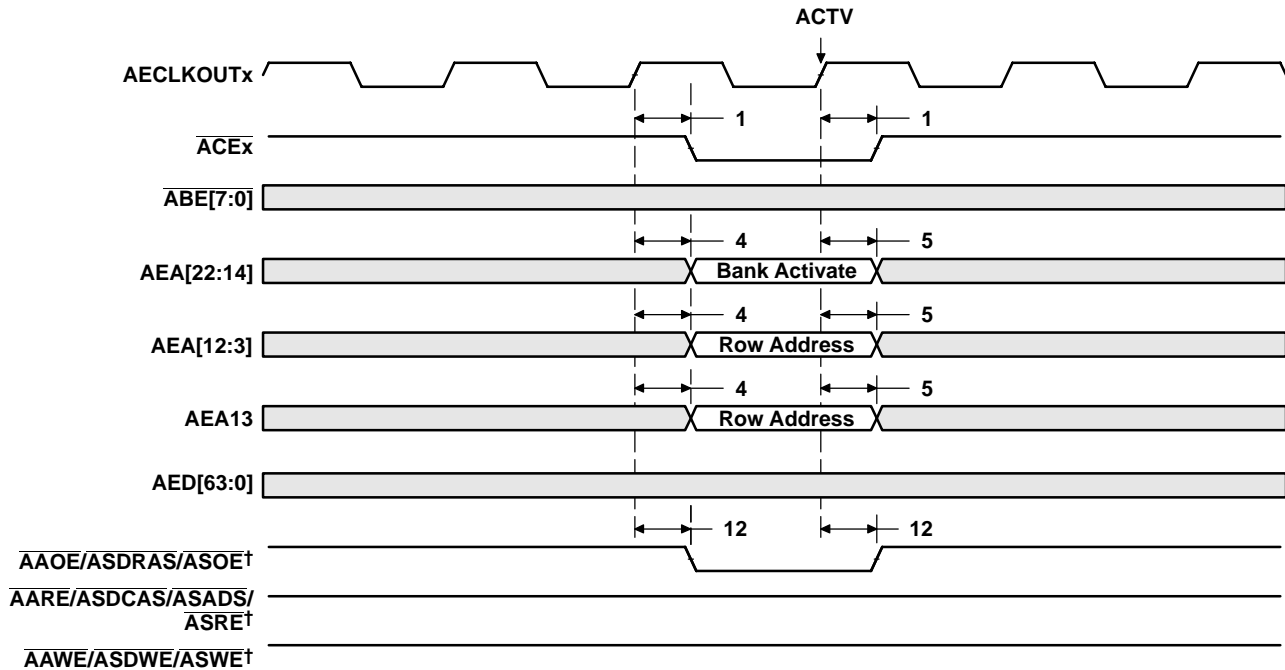

† AARE/ASDCAS/ASADS/ASRE, AAWE/ASDWE/ASWE, and AAOE/ASDRAS/ASOE operate as ASDCAS, ASDWE, and ASDRAS, respectively, during SDRAM accesses.

Figure 7–3. SDRAM ACTV Command for EMIFA

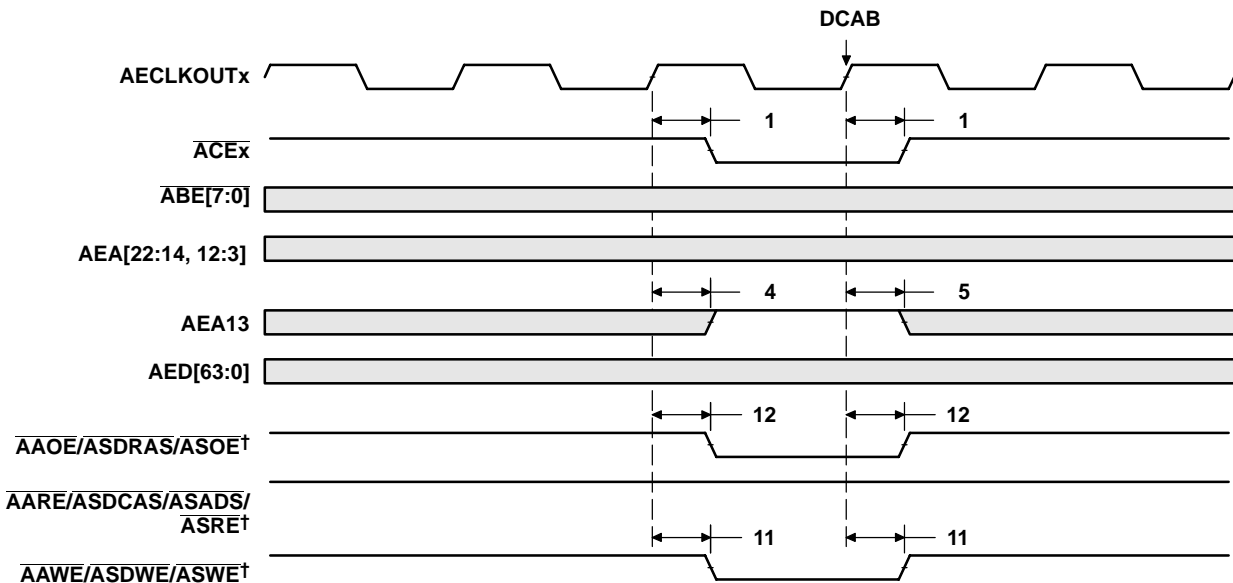

† AARE/ASDCAS/ASADS/ASRE, AAWE/ASDWE/ASWE, and AAOE/ASDRAS/ASOE operate as ASDCAS, ASDWE, and ASDRAS, respectively, during SDRAM accesses.

Figure 7–4. SDRAM DCAB Command for EMIFA

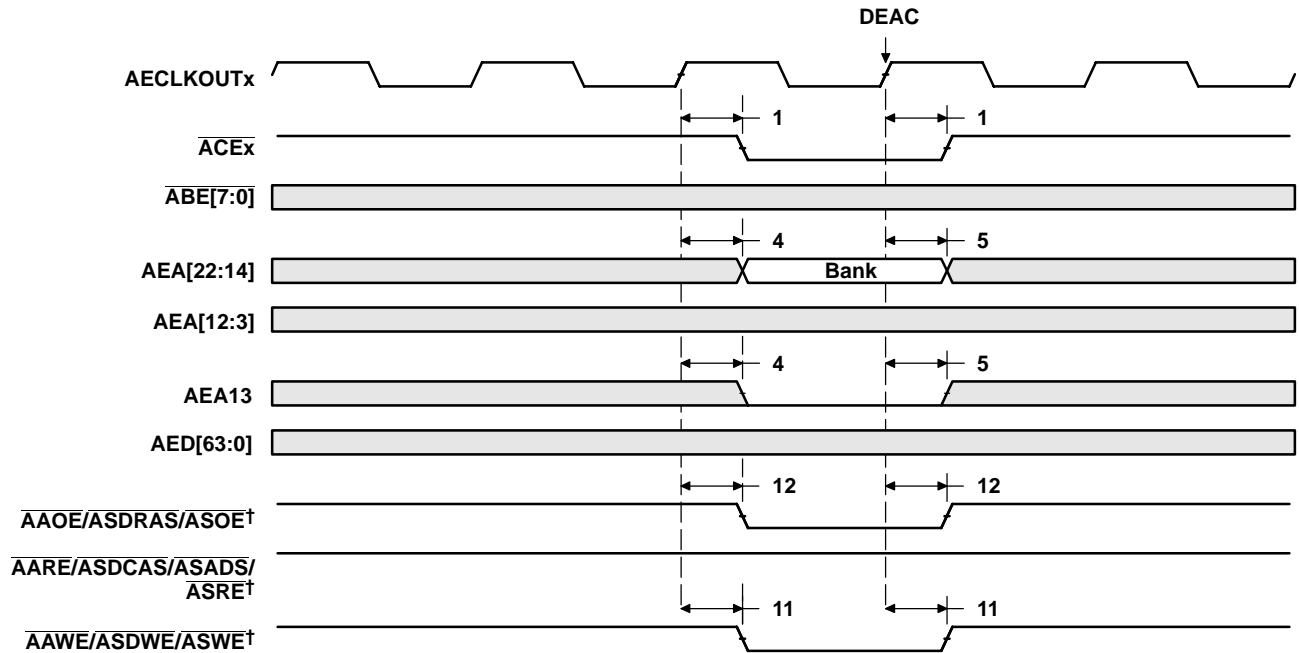

† AARE/ASDCAS/ASADS/ASRE, AAWE/ASDWE/ASWE, and AAOE/ASDRAS/ASOE operate as ASDCAS, ASDWE, and ASDRAS, respectively, during SDRAM accesses.

Figure 7-5. SDRAM DEAC Command for EMIFA

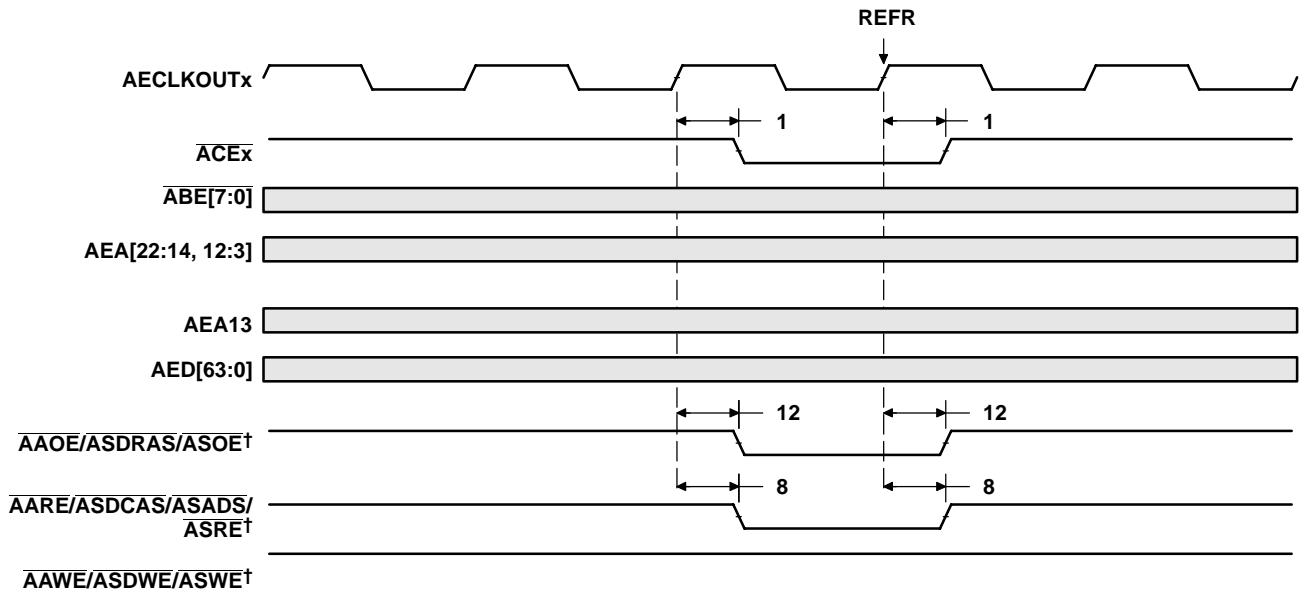

† AARE/ASDCAS/ASADS/ASRE, AAWE/ASDWE/ASWE, and AAOE/ASDRAS/ASOE operate as ASDCAS, ASDWE, and ASDRAS, respectively, during SDRAM accesses.

Figure 7-6. SDRAM REFR Command for EMIFA

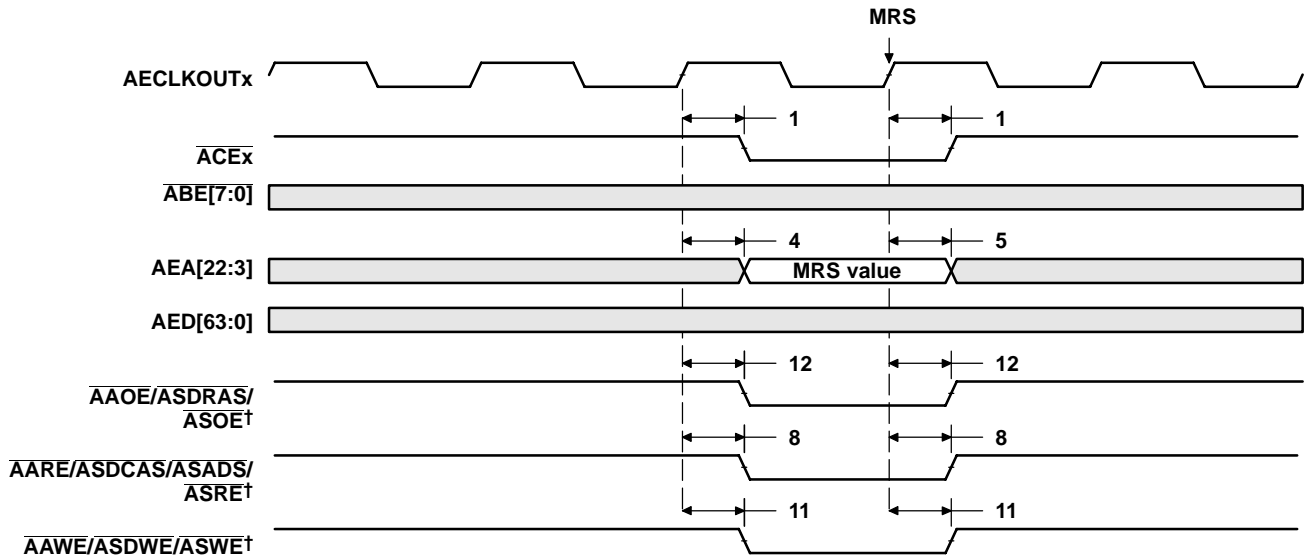

† AARE/ASDCAS/ASADS/ASRE, AAWE/ASDWE/ASWE, and AAOE/ASDRAS/ASOE operate as ASDCAS, ASDWE, and ASDRAS, respectively, during SDRAM accesses.

Figure 7-7. SDRAM MRS Command for EMIFA

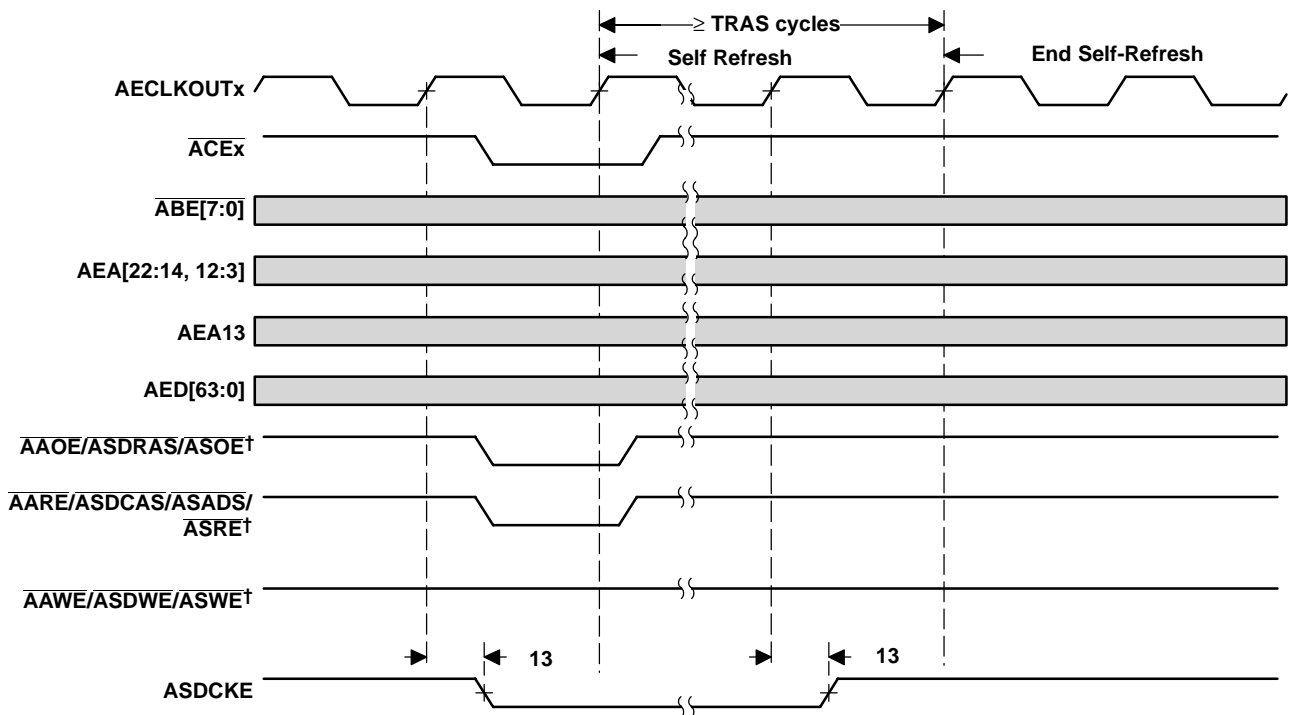

† AARE/ASDCAS/ASADS/ASRE, AAWE/ASDWE/ASWE, and AAOE/ASDRAS/ASOE operate as ASDCAS, ASDWE, and ASDRAS, respectively, during SDRAM accesses.

Figure 7-8. SDRAM Self-Refresh Timing for EMIFA

8 HOLD/HOLDA Timing

Table 8–1. Timing Requirements for the HOLD/HOLDA Cycles for EMIFA Module† (see Figure 8–1)

| NO. | | –500 | | –600 –720 | | UNIT |
|-----|---|------|-----|--------------|-----|------|
| | | MIN | MAX | MIN | MAX | |
| 3 | $t_{h(HOLDAL-HOLDL)}$ Hold time, \overline{HOLD} low after \overline{HOLDA} low | E | | E | | ns |

† E = the EMIF input clock (AECLKIN, CPU/4 clock, or CPU/6 clock) period in ns for EMIFA.

Table 8–2. Switching Characteristics Over Recommended Operating Conditions for the HOLD/HOLDA Cycles for EMIFA Module†‡§ (see Figure 8–1)

| NO. | PARAMETER | –500 | | –600 –720 | | UNIT |
|-----|---|------|-----|--------------|-----|------|
| | | MIN | MAX | MIN | MAX | |
| 1 | $t_{d(HOLDL-EMHZ)}$ Delay time, \overline{HOLD} low to EMIFA Bus high impedance | 2E | ¶ | 2E | ¶ | ns |
| 2 | $t_{d(EMHZ-HOLDAL)}$ Delay time, EMIF Bus high impedance to \overline{HOLDA} low | 0 | 2E | 0 | 2E | ns |
| 4 | $t_{d(HOLDH-EMLZ)}$ Delay time, \overline{HOLD} high to EMIF Bus low impedance | 2E | 7E | 2E | 7E | ns |
| 5 | $t_{d(EMLZ-HOLDAH)}$ Delay time, EMIFA Bus low impedance to \overline{HOLDA} high | 0 | 2E | 0 | 2E | ns |
| 6 | $t_{d(HOLDL-EKOHZ)}$ Delay time, \overline{HOLD} low to AECLKOUTx high impedance | 2E | ¶ | 2E | ¶ | ns |
| 7 | $t_{d(HOLDH-EKOLZ)}$ Delay time, \overline{HOLD} high to AECLKOUTx low impedance | 2E | 7E | 2E <td 7E | ns | |

† E = the EMIF input clock (AECLKIN, CPU/4 clock, or CPU/6 clock) period in ns for EMIFA.

‡ EMIFA Bus consists of: $\overline{ACE}[3:0]$, $\overline{ABE}[7:0]$, $\overline{AED}[63:0]$, $\overline{AEA}[22:3]$, $\overline{AARE}/\overline{ASDCAS}/\overline{ASADS}/\overline{ASRE}$, $\overline{AAOE}/\overline{ASDRAS}/\overline{ASOE}$, and $\overline{AAWE}/\overline{ASDWE}/\overline{ASWE}$, \overline{ASDCKE} , $\overline{ASOE3}$, and \overline{APDT} .

§ The EKxHZ bits in the EMIF Global Control register (GBLCTL) determine the state of the AECLKOUTx signals during \overline{HOLDA} . If EKxHZ = 0, AECLKOUTx continues clocking during Hold mode. If EKxHZ = 1, AECLKOUTx goes to high impedance during Hold mode, as shown in Figure 8–1.

¶ All pending EMIF transactions are allowed to complete before \overline{HOLDA} is asserted. If no bus transactions are occurring, then the minimum delay time can be achieved. Also, bus hold can be indefinitely delayed by setting NOHOLD = 1.

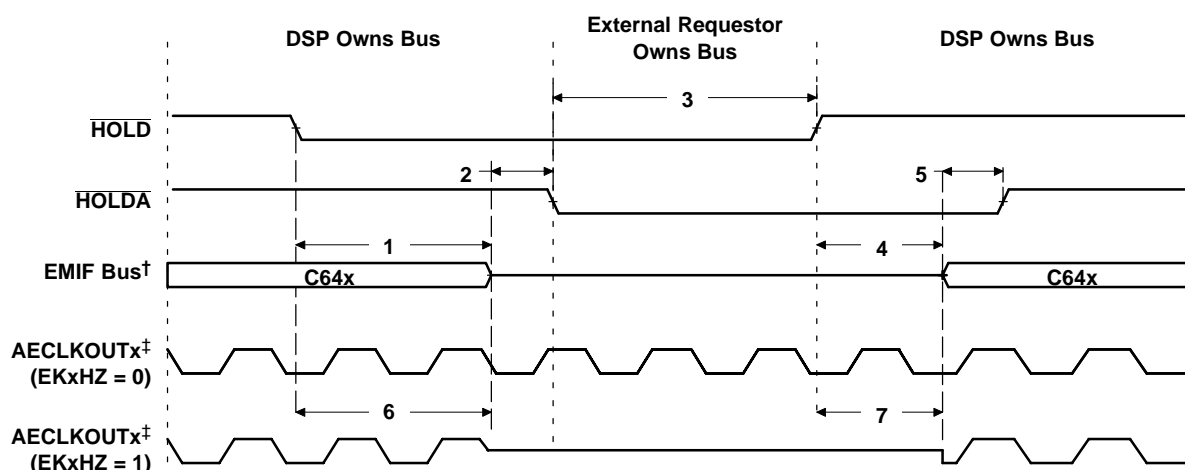

† EMIFA Bus consists of: $\overline{ACE}[3:0]$, $\overline{ABE}[7:0]$, $\overline{AED}[63:0]$, $\overline{AEA}[22:3]$, $\overline{AARE}/\overline{ASDCAS}/\overline{ASADS}/\overline{ASRE}$, $\overline{AAOE}/\overline{ASDRAS}/\overline{ASOE}$, and $\overline{AAWE}/\overline{ASDWE}/\overline{ASWE}$, \overline{ASDCKE} , $\overline{ASOE3}$, and \overline{APDT} .

‡ The EKxHZ bits in the EMIF Global Control register (GBLCTL) determine the state of the AECLKOUTx signals during \overline{HOLDA} . If EKxHZ = 0, AECLKOUTx continues clocking during Hold mode. If EKxHZ = 1, AECLKOUTx goes to high impedance during Hold mode, as shown in Figure 8–1.

Figure 8–1. HOLD/HOLDA Timing for EMIFA

9 BUSREQ Timing

Table 9–1. Switching Characteristics Over Recommended Operating Conditions for the BUSREQ Cycles for EMIFA Module (see Figure 9–1)

| NO. | PARAMETER | –500 | | –600 –720 | | UNIT |
|-----|--|------|-----|--------------|-----|------|
| | | MIN | MAX | MIN | MAX | |
| 1 | $t_{d(AEKO1H-ABUSRV)}$ Delay time, AECLKOUTx high to ABUSREQ valid | 0.6 | 7.1 | 1 | 5.5 | ns |

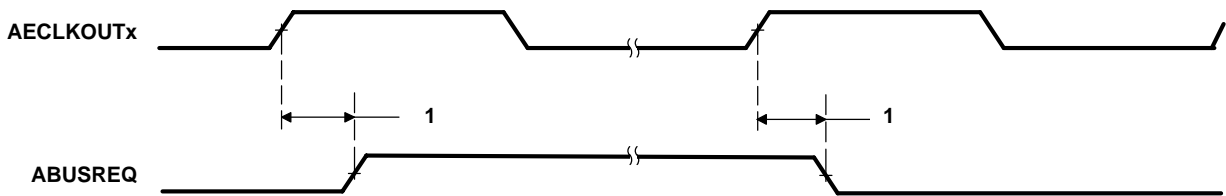

Figure 9–1. BUSREQ Timing for EMIFA

10 Reset Timing

Table 10–1. Timing Requirements for Reset (see Figure 10–1)

| NO. | | | -500 -600 -720 | | UNIT |
|-----|---------------------|---|-----------------------|-----|---------|
| | | | MIN | MAX | |
| 1 | $t_{w(RST)}$ | Width of the \overline{RESET} pulse | 250 | | μs |
| 16 | $t_{su(boot)}$ | Setup time, boot configuration bits valid before \overline{RESET} high [†] | 4E or 4C [‡] | | ns |
| 17 | $t_{h(boot)}$ | Hold time, boot configuration bits valid after \overline{RESET} high [†] | 4P [§] | | ns |
| 18 | $t_{su(PCLK-RSTH)}$ | Setup time, PCLK active before \overline{RESET} high [¶] | 32N | | ns |

[†] AEA[22:19], LENDIAN, PCIEEAI, and HD5/AD5 are the boot configuration pins during device reset.

[‡] E = 1/AECLKIN clock frequency in ns. C = 1/CLKIN clock frequency in ns.

Select the MIN parameter value, whichever value is larger.

[§] P = 1/CPU clock frequency in ns. For example, when running parts at 600 MHz, use P = 1.67 ns.

[¶] N = the PCI input clock (PCLK) period in ns. When PCI is enabled (PCI_EN = 1), this parameter *must* be met.

Table 10–2. Switching Characteristics Over Recommended Operating Conditions During Reset^{§#||}
(see Figure 10–1)

| NO. | PARAMETER | -500 -600 -720 | | UNIT |
|-----|-----------------------|--|-----|-----------------|
| | | MIN | MAX | |
| 2 | $t_{d(RSTL-ECKI)}$ | Delay time, \overline{RESET} low to AECLKIN synchronized internally | | 2E 3P + 20E ns |
| 3 | $t_{d(RSTH-ECKI)}$ | Delay time, \overline{RESET} high to AECLKIN synchronized internally | | 2E 8P + 20E ns |
| 4 | $t_{d(RSTL-ECKO1HZ)}$ | Delay time, \overline{RESET} low to AECLKOUT1 high impedance | | 2E ns |
| 5 | $t_{d(RSTH-ECKO1V)}$ | Delay time, \overline{RESET} high to AECLKOUT1 valid | | 8P + 20E ns |
| 6 | $t_{d(RSTL-EMIFZH)}$ | Delay time, \overline{RESET} low to EMIF Z high impedance | | 2E 3P + 4E ns |
| 7 | $t_{d(RSTH-EMIFZV)}$ | Delay time, \overline{RESET} high to EMIF Z valid | | 16E 8P + 20E ns |
| 8 | $t_{d(RSTL-EMIFHIV)}$ | Delay time, \overline{RESET} low to EMIF high group invalid | | 2E ns |
| 9 | $t_{d(RSTH-EMIFHV)}$ | Delay time, \overline{RESET} high to EMIF high group valid | | 8P + 20E ns |
| 10 | $t_{d(RSTL-EMIFLIV)}$ | Delay time, \overline{RESET} low to EMIF low group invalid | | 2E ns |
| 11 | $t_{d(RSTH-EMIFLV)}$ | Delay time, \overline{RESET} high to EMIF low group valid | | 8P + 20E ns |
| 12 | $t_{d(RSTL-LOWIV)}$ | Delay time, \overline{RESET} low to low group invalid | | 0 ns |
| 13 | $t_{d(RSTH-LOWV)}$ | Delay time, \overline{RESET} high to low group valid | | 11P ns |
| 14 | $t_{d(RSTL-ZHZ)}$ | Delay time, \overline{RESET} low to Z group high impedance | | 0 ns |
| 15 | $t_{d(RSTH-ZV)}$ | Delay time, \overline{RESET} high to Z group valid | | 2P 8P ns |

[§] P = 1/CPU clock frequency in ns. For example, when running parts at 600 MHz, use P = 1.67 ns.

[#] E = the EMIF input clock (AECLKIN, CPU/4 clock, or CPU/6 clock) period in ns for EMIFA.

^{||} EMIF Z group consists of: AEA[22:3], AED[63:0], ACE[3:0], ABE[7:0], AARE/ASDCAS/ASADS/ASRE, AAW/ASDWE/ASWE, and AAOE/ASDRAS/ASOE, ASOE3, ASDCKE, and APDT.

EMIF high group consists of: \overline{AHOLDA} (when the corresponding \overline{HOLD} input is high)

EMIF low group consists of: $\overline{ABUSREQ}$; \overline{AHOLDA} (when the corresponding \overline{HOLD} input is low)

Low group consists of: XSP_CS, XSP_CLK/MDCLK, and XSP_DO/MDIO; all of which apply only when PCI EEPROM is enabled (with PCI_EN = 1). Otherwise, the XSP_CLK/MDCLK and XSP_DO/MDIO pins are in the

Z group. For more details on the PCI configuration pins, see the Device Configurations section of this data sheet.

HD[31:0]/AD[31:0] and the muxed EMAC output pins, XSP_CLK/MDCLK, XSP_DO/MDIO, CLKX0,

CLKX1, FSX0, FSX1, DX0, DX1, CLKR0, CLKR1, FSR0, FSR1, TOUT0, TOUT1,

GP0[8]/PCI66, GP0[7:0], GP0[10]/PCBE3, HR/W/PCBE1, HDS2/PCBE1, PCBE0, GP0[13]/PINTA,

GP0[11]/PREQ, HDS1/PSERR, HCS/PPERR, HCNLT1/PDEVSEL, HAS/PPAR, HCNLT0/PSTOP,

HHWIL/PTRDY (16-bit HPI mode only), HRDY/PIRDY, and HINT/PFRAME.

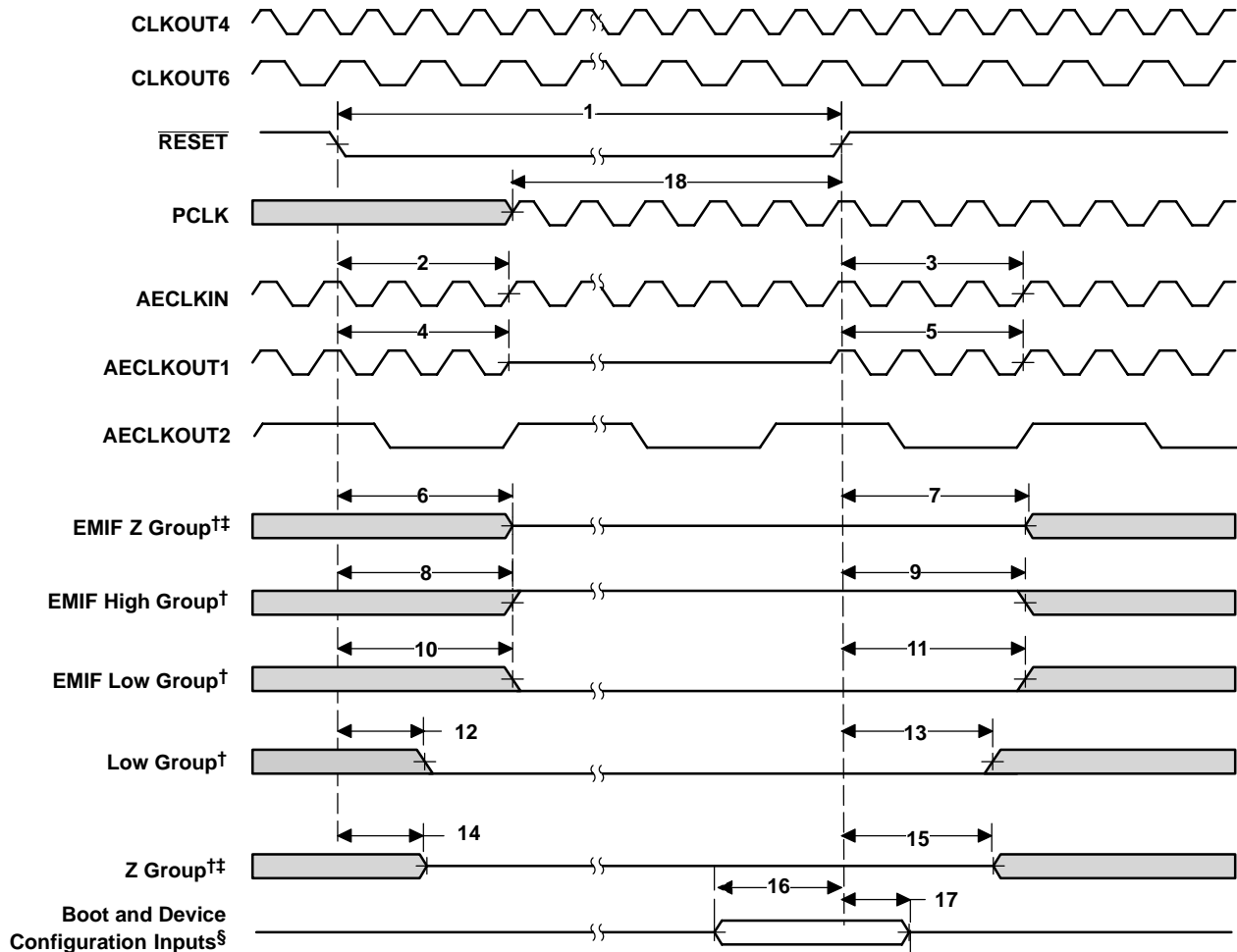

† EMIF Z group consists of: AEA[22:3], AED[63:0], ACE[3:0], ABE[7:0], AARE/ASDCAS/ASADS/ASRE,AAWE/ASDWE/ASWE, and AAOE/ASDRAS/ASOE, ASOE3, ASDCKE, and APDT.
 EMIF high group consists of: AHOLDA (when the corresponding HOLD input is high)
 EMIF low group consists of: ABUSREQ; AHOLDA (when the corresponding HOLD input is low)
 Low group consists of: XSP_CS, XSP_CLK/MDCLK, and XSP_DO/MDIO; all of which apply only when PCI EEPROM is enabled (with PCI_EN = 1). Otherwise, the XSP_CLK/MDCLK and XSP_DO/MDIO pins are in the Z group. For more details on the PCI configuration pins, see the Device Configurations section of this data sheet.
 Z group consists of: HD[31:0]/AD[31:0] and the muxed EMAC output pins, XSP_CLK/MDCLK, XSP_DO/MDIO, CLKX0, CLKX1, FSX0, FSX1, DX0, DX1, CLKR0, CLKR1, FSR0, FSR1, TOUT0, TOUT1, GP0[8]/PCI66, GP0[7:0], GP0[10]/PCBE3, HR/W/PCBE2, HDS2/PCBE1, PCBE0, GP0[13]/PINTA, GP0[11]/PREQ, HDS1/PSERR, HCS/PPERR, HCNTL1/PDEVSEL, HAS/PPAR, HCNTL0/PSTOP, HHWIL/PTRDY (16-bit HPI mode only), HRDY/PIRDY, and HINT/PFRAME.
 ‡ If AEA[22:19], LENDIAN, PCIEEI, MAC_EN, and HD5/AD5 pins are actively driven, care must be taken to ensure no timing contention between parameters 6, 7, 14, 15, 16, and 17.
 § Boot and Device Configurations Inputs (during reset) include: AEA[22:19],LENDIAN, PCIEEI, MAC_EN, and HD5/AD5. The LENDIAN and MAC_EN configuration inputs are muxed with timer output pins and driven low after reset; therefore, it is recommended that external pullup/pulldown resistors be used to configure these pins during reset and that these pins **not** be driven through external logic. The PCI_EN pin *must* be valid at all times and the user *must not* switch values throughout device operation.

Figure 10–1. Reset Timing†

11 External Interrupt Timing

Table 11–1. Timing Requirements for External Interrupts[†] (see Figure 11–1)

| NO. | | | -500 -600 -720 | UNIT |
|-----|----------------|---|----------------------|------|
| | | | MIN | MAX |
| 1 | $t_{w(ILOW)}$ | Width of the NMI interrupt pulse low | 4P | ns |
| | | Width of the EXT_INT interrupt pulse low | 8P | ns |
| 2 | $t_{w(IHIGH)}$ | Width of the NMI interrupt pulse high | 4P | ns |
| | | Width of the EXT_INT interrupt pulse high | 8P | ns |

[†] P = 1/CPU clock frequency in ns. For example, when running parts at 600 MHz, use P = 1.67 ns.

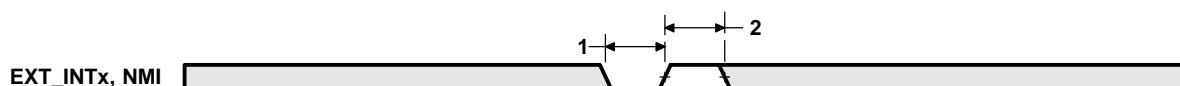

Figure 11–1. External/NMI Interrupt Timing

12 Inter-Integrated Circuits (I2C) Timing

Table 12–1. Timing Requirements for I2C Timings† (see Figure 12–1)

| NO. | | –500 –600 –720 | | | | UNIT |
|-----|---|----------------------|-----|------------------|------|---------------|
| | | STANDARD MODE | | FAST MODE | | |
| | | MIN | MAX | MIN | MAX | |
| 1 | $t_c(\text{SCL})$ Cycle time, SCL | 10 | | 2.5 | | μs |
| 2 | $t_{su}(\text{SCLH-SDAL})$ Setup time, SCL high before SDA low (for a repeated START condition) | 4.7 | | 0.6 | | μs |
| 3 | $t_h(\text{SCLL-SDAL})$ Hold time, SCL low after SDA low (for a START and a repeated START condition) | 4 | | 0.6 | | μs |
| 4 | $t_w(\text{SCLL})$ Pulse duration, SCL low | 4.7 | | 1.3 | | μs |
| 5 | $t_w(\text{SCLH})$ Pulse duration, SCL high | 4 | | 0.6 | | μs |
| 6 | $t_{su}(\text{SDAV-SDLH})$ Setup time, SDA valid before SCL high | 250 | | 100‡ | | ns |
| 7 | $t_h(\text{SDA-SDLL})$ Hold time, SDA valid after SCL low (For I ² C bus™ devices) | 0§ | | 0§ | 0.9¶ | μs |
| 8 | $t_w(\text{SDAH})$ Pulse duration, SDA high between STOP and START conditions | 4.7 | | 1.3 | | μs |
| 9 | $t_r(\text{SDA})$ Rise time, SDA | 1000 | | $20 + 0.1C_b^\#$ | 300 | ns |
| 10 | $t_r(\text{SCL})$ Rise time, SCL | 1000 | | $20 + 0.1C_b^\#$ | 300 | ns |
| 11 | $t_f(\text{SDA})$ Fall time, SDA | 300 | | $20 + 0.1C_b^\#$ | 300 | ns |
| 12 | $t_f(\text{SCL})$ Fall time, SCL | 300 | | $20 + 0.1C_b^\#$ | 300 | ns |
| 13 | $t_{su}(\text{SCLH-SDAH})$ Setup time, SCL high before SDA high (for STOP condition) | 4 | | 0.6 | | μs |
| 14 | $t_w(\text{SP})$ Pulse duration, spike (must be suppressed) | | | 0 | 50 | ns |
| 15 | $C_b^\#$ Capacitive load for each bus line | 400 | | 400 | | pF |

† The I2C pins SDA and SCL do not feature fail-safe I/O buffers. These pins could potentially draw current when the device is powered down.

‡ A Fast-mode I²C-bus™ device can be used in a Standard-mode I²C-bus™ system, but the requirement $t_{su}(\text{SDA-SCLH}) \geq 250$ ns must then be met. This will automatically be the case if the device does not stretch the LOW period of the SCL signal. If such a device does stretch the LOW period of the SCL signal, it must output the next data bit to the SDA line $t_r \text{ max} + t_{su}(\text{SDA-SCLH}) = 1000 + 250 = 1250$ ns (according to the Standard-mode I²C-Bus Specification) before the SCL line is released.

§ A device must internally provide a hold time of at least 300 ns for the SDA signal (referred to the V_{IHmin} of the SCL signal) to bridge the undefined region of the falling edge of SCL.

¶ The maximum $t_h(\text{SDA-SCLL})$ has only to be met if the device does not stretch the low period [$t_w(\text{SCLL})$] of the SCL signal.

C_b = total capacitance of one bus line in pF. If mixed with HS-mode devices, faster fall-times are allowed.

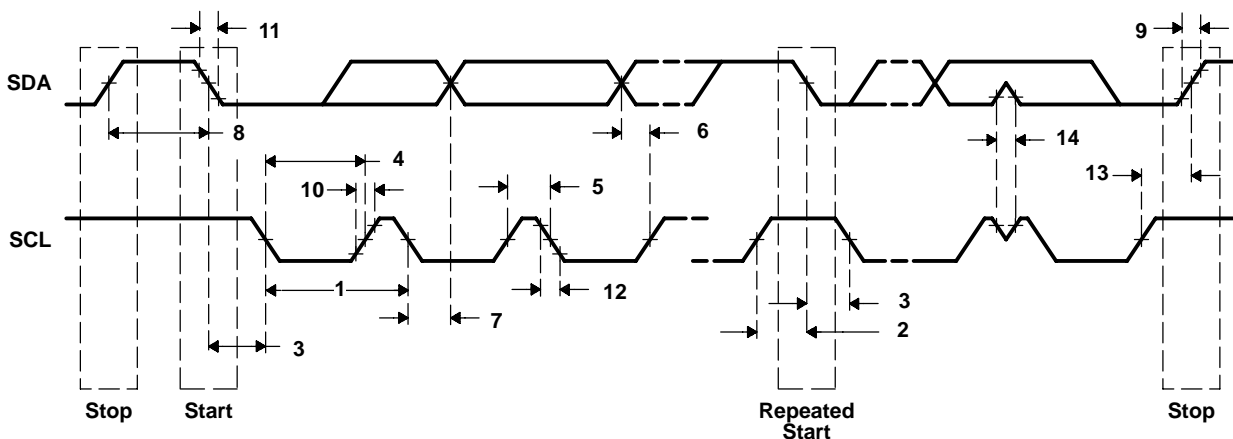

Figure 12–1. I2C Receive Timings

Table 12–2. Switching Characteristics for I2C Timings[†] (see Figure 12–2)

| NO. | PARAMETER | –500 –600 –720 | | | | UNIT |
|-----|--|----------------------|-----|-------------------------|-----|---------------|
| | | STANDARD MODE | | FAST MODE | | |
| | | MIN | MAX | MIN | MAX | |
| 16 | $t_{c(SCL)}$ Cycle time, SCL | 10 | | 2.5 | | μs |
| 17 | $t_{d(SCLH-SDAL)}$ Delay time, SCL high to SDA low (for a repeated START condition) | 4.7 | | 0.6 | | μs |
| 18 | $t_{d(SDAL-SCLL)}$ Delay time, SDA low to SCL low (for a START and a repeated START condition) | 4 | | 0.6 | | μs |
| 19 | $t_{w(SCLL)}$ Pulse duration, SCL low | 4.7 | | 1.3 | | μs |
| 20 | $t_{w(SCLH)}$ Pulse duration, SCL high | 4 | | 0.6 | | μs |
| 21 | $t_{d(SDAV-SDLH)}$ Delay time, SDA valid to SCL high | 250 | | 100 | | ns |
| 22 | $t_{v(SDLL-SDAV)}$ Valid time, SDA valid after SCL low (For I ² C bus™ devices) | 0 | | 0 | 0.9 | μs |
| 23 | $t_{w(SDAH)}$ Pulse duration, SDA high between STOP and START conditions | 4.7 | | 1.3 | | μs |
| 24 | $t_{r(SDA)}$ Rise time, SDA | 1000 | | $20 + 0.1C_b^{\dagger}$ | 300 | ns |
| 25 | $t_{r(SCL)}$ Rise time, SCL | 1000 | | $20 + 0.1C_b^{\dagger}$ | 300 | ns |
| 26 | $t_{f(SDA)}$ Fall time, SDA | 300 | | $20 + 0.1C_b^{\dagger}$ | 300 | ns |
| 27 | $t_{f(SCL)}$ Fall time, SCL | 300 | | $20 + 0.1C_b^{\dagger}$ | 300 | ns |
| 28 | $t_{d(SCLH-SDAH)}$ Delay time, SCL high to SDA high (for STOP condition) | 4 | | 0.6 | | μs |
| 29 | C_p Capacitance for each I2C pin | 10 | | 10 | | pF |

[†] C_b = total capacitance of one bus line in pF. If mixed with HS-mode devices, faster fall-times are allowed.

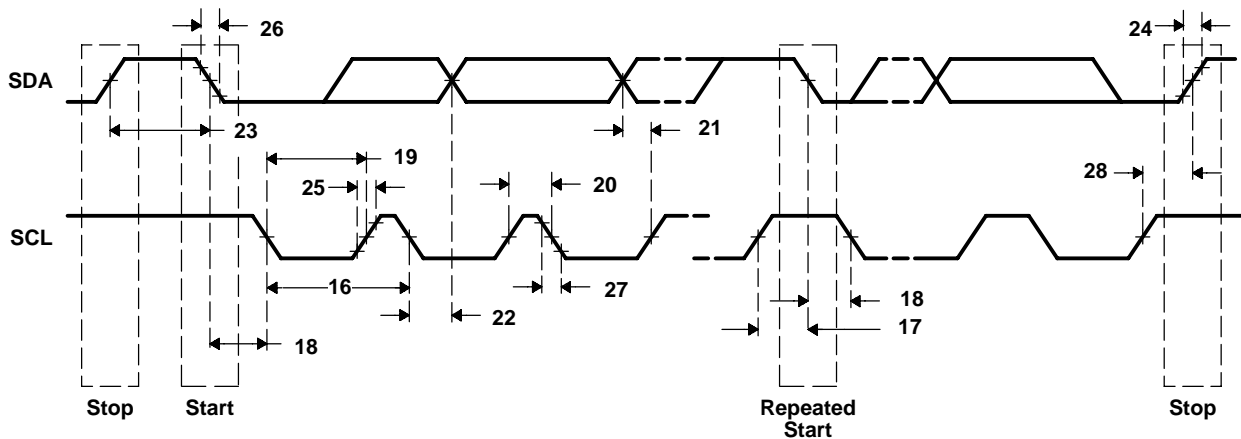

Figure 12–2. I2C Transmit Timings

13 Host-Port Interface (HPI) Timing

Table 13–1. Timing Requirements for Host-Port Interface Cycles^{†‡} (see Figure 13–1 through Figure 13–8)

| NO. | | | -500 -600 -720 | | UNIT |
|-----|----------------------|--|----------------------|-----|------|
| | | | MIN | MAX | |
| 1 | $t_{su}(SELV-HSTBL)$ | Setup time, select signals [§] valid before $\overline{HSTROBE}$ low | 5 | | ns |
| 2 | $t_h(HSTBL-SELV)$ | Hold time, select signals [§] valid after $\overline{HSTROBE}$ low | 2.4 | | ns |
| 3 | $t_w(HSTBL)$ | Pulse duration, $\overline{HSTROBE}$ low | 4P [¶] | | ns |
| 4 | $t_w(HSTBH)$ | Pulse duration, $\overline{HSTROBE}$ high between consecutive accesses | 4P | | ns |
| 10 | $t_{su}(SELV-HASL)$ | Setup time, select signals [§] valid before \overline{HAS} low | 5 | | ns |
| 11 | $t_h(HASL-SELV)$ | Hold time, select signals [§] valid after \overline{HAS} low | 2 | | ns |
| 12 | $t_{su}(HDV-HSTBH)$ | Setup time, host data valid before $\overline{HSTROBE}$ high | 5 | | ns |
| 13 | $t_h(HSTBH-HDV)$ | Hold time, host data valid after $\overline{HSTROBE}$ high | 2.8 | | ns |
| 14 | $t_h(HRDYL-HSTBL)$ | Hold time, $\overline{HSTROBE}$ low after \overline{HRDY} low. $\overline{HSTROBE}$ should not be inactivated until \overline{HRDY} is active (low); otherwise, HPI writes will not complete properly. | 2 | | ns |
| 18 | $t_{su}(HASL-HSTBL)$ | Setup time, \overline{HAS} low before $\overline{HSTROBE}$ low | 2 | | ns |
| 19 | $t_h(HSTBL-HASL)$ | Hold time, \overline{HAS} low after $\overline{HSTROBE}$ low | 2.1 | | ns |

[†] $\overline{HSTROBE}$ refers to the following logical operation on \overline{HCS} , $\overline{HDS1}$, and $\overline{HDS2}$: $[\text{NOT}(\overline{HDS1} \text{ XOR } \overline{HDS2})]$ OR \overline{HCS} .

[‡] $P = 1/\text{CPU clock frequency}$ in ns. For example, when running parts at 600 MHz, use $P = 1.67$ ns.

[§] Select signals include: $\overline{HCNTL}[1:0]$ and $\overline{HR}/\overline{W}$. For HPI16 mode only, select signals also include \overline{HHWIL} .

[¶] Select the parameter value of 4P or 12.5 ns, whichever is larger.

Table 13–2. Switching Characteristics Over Recommended Operating Conditions During Host-Port Interface Cycles^{†‡} (see Figure 13–1 through Figure 13–8)

| NO. | PARAMETER | | -500 -600 -720 | | UNIT |
|-----|---------------------|---|----------------------|--------|------|
| | | | MIN | MAX | |
| 6 | $t_d(HSTBL-HRDYH)$ | Delay time, $\overline{HSTROBE}$ low to \overline{HRDY} high [#] | 1.3 | 4P + 8 | ns |
| 7 | $t_d(HSTBL-HDLZ)$ | Delay time, $\overline{HSTROBE}$ low to HD low impedance for an HPI read | 2 | | ns |
| 8 | $t_d(HDV-HRDYL)$ | Delay time, HD valid to \overline{HRDY} low | -3 | | ns |
| 9 | $t_{oh}(HSTBH-HDV)$ | Output hold time, HD valid after $\overline{HSTROBE}$ high | 1.5 | | ns |
| 15 | $t_d(HSTBH-HDHZ)$ | Delay time, $\overline{HSTROBE}$ high to HD high impedance | | 12 | ns |
| 16 | $t_d(HSTBL-HDV)$ | Delay time, $\overline{HSTROBE}$ low to HD valid (HPI16 mode, 2nd half-word only) | | 4P + 8 | ns |

[†] $\overline{HSTROBE}$ refers to the following logical operation on \overline{HCS} , $\overline{HDS1}$, and $\overline{HDS2}$: $[\text{NOT}(\overline{HDS1} \text{ XOR } \overline{HDS2})]$ OR \overline{HCS} .

[‡] $P = 1/\text{CPU clock frequency}$ in ns. For example, when running parts at 600 MHz, use $P = 1.67$ ns.

[#] This parameter is used during HPID reads and writes. For reads, at the beginning of a word transfer (HPI32) or the first half-word transfer (HPI16) on the falling edge of $\overline{HSTROBE}$, the HPI sends the request to the EDMA internal address generation hardware, and \overline{HRDY} remains high until the EDMA internal address generation hardware loads the requested data into HPID. For writes, \overline{HRDY} goes high if the internal write buffer is full.

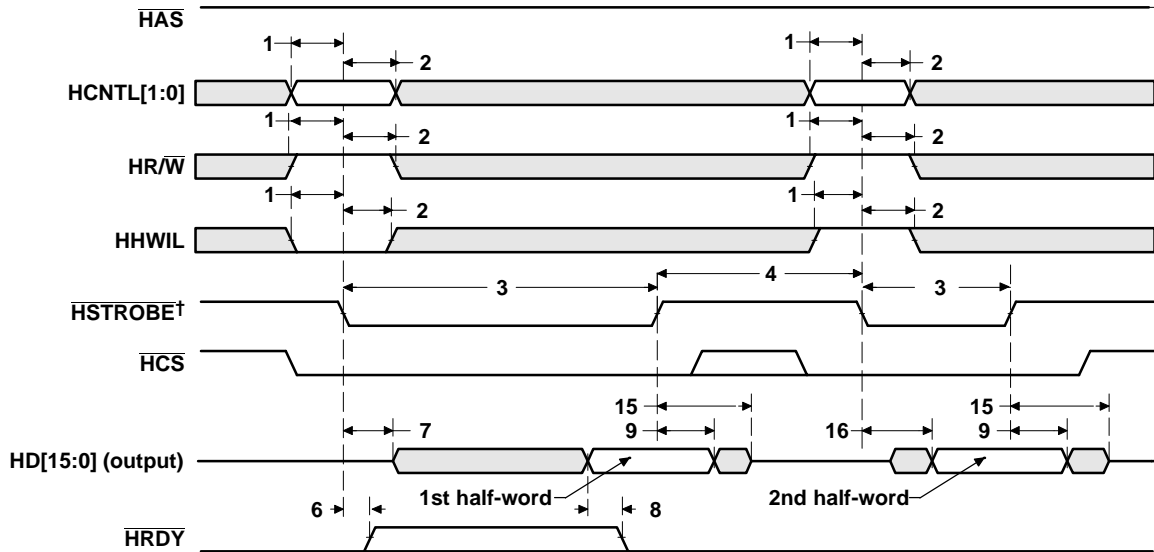

† HSTROBE refers to the following logical operation on HCS , HDS1 , and HDS2 : $[\text{NOT}(\text{HDS1 XOR HDS2})] \text{ OR } \text{HCS}$.

Figure 13–1. HPI16 Read Timing ($\overline{\text{HAS}}$ Not Used, Tied High)

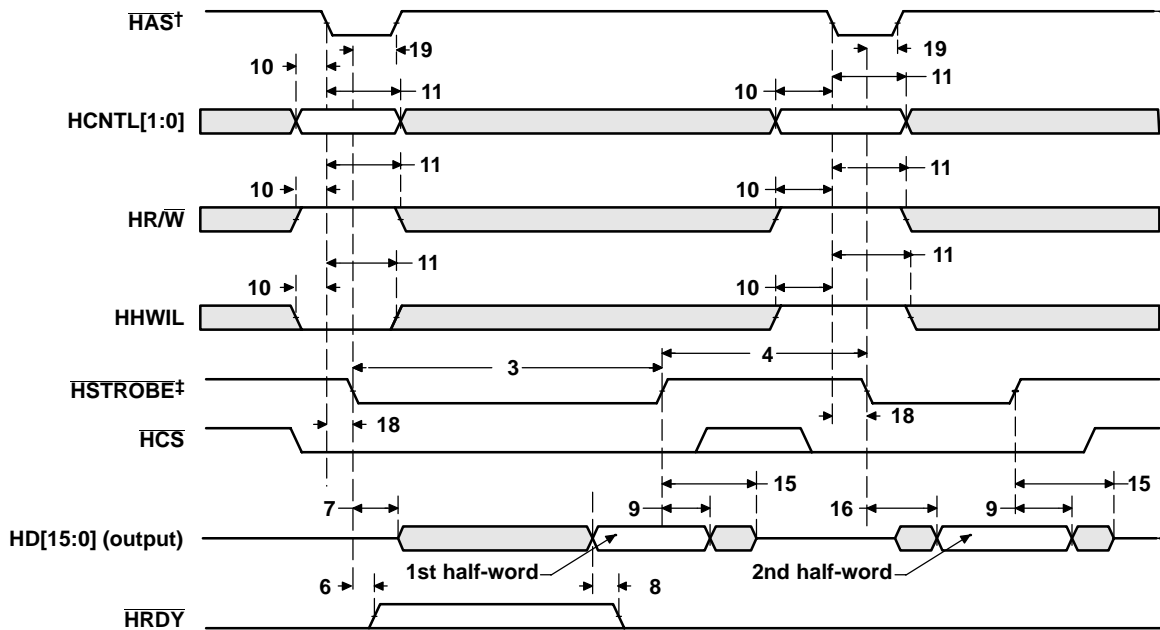

† For correct operation, strobe the $\overline{\text{HAS}}$ signal only once per HSTROBE active cycle.

‡ HSTROBE refers to the following logical operation on HCS , HDS1 , and HDS2 : $[\text{NOT}(\text{HDS1 XOR HDS2})] \text{ OR } \text{HCS}$.

Figure 13–2. HPI16 Read Timing ($\overline{\text{HAS}}$ Used)

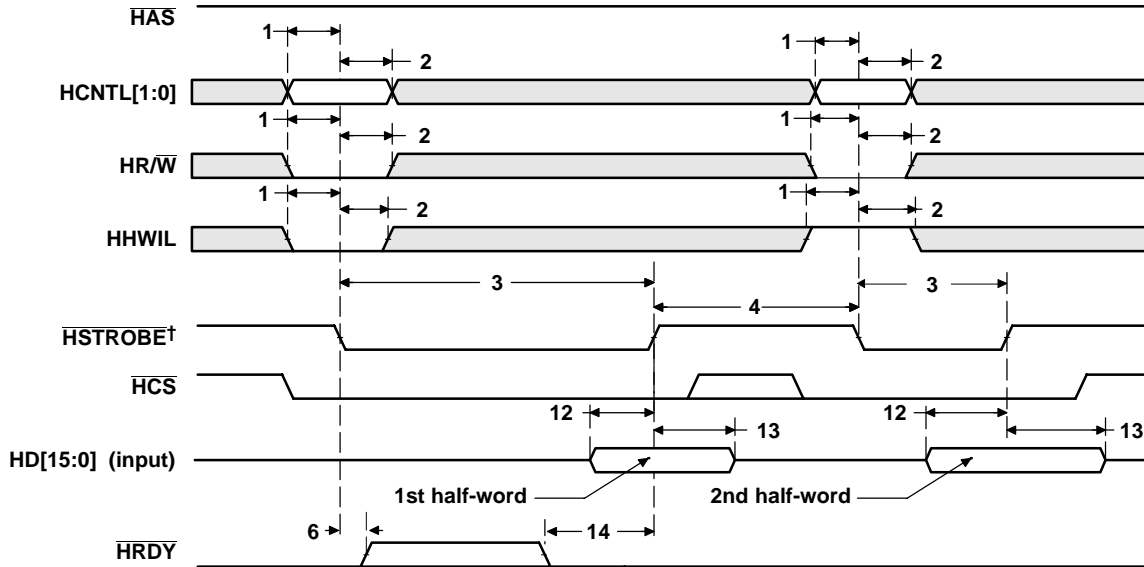

† HSTROBE refers to the following logical operation on HCS, HDS1, and HDS2: [NOT(HDS1 XOR HDS2)] OR HCS.

Figure 13-3. HPI16 Write Timing (HAS Not Used, Tied High)

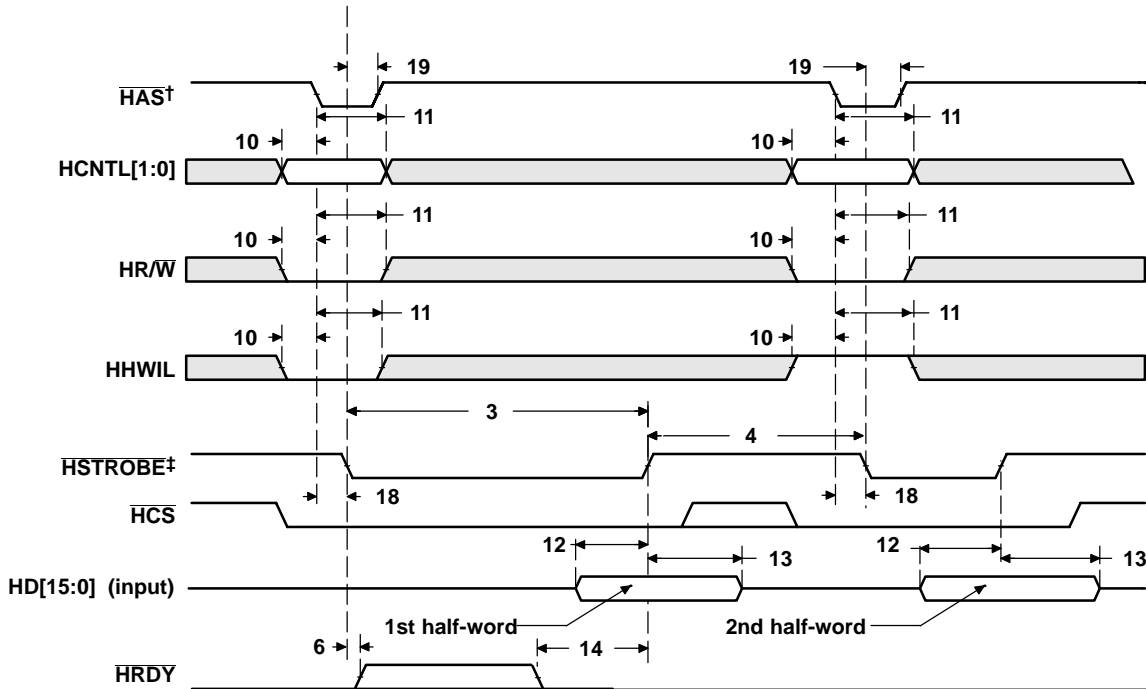

† For correct operation, strobe the HAS signal only once per HSTROBE active cycle.

‡ HSTROBE refers to the following logical operation on HCS, HDS1, and HDS2: [NOT(HDS1 XOR HDS2)] OR HCS.

Figure 13-4. HPI16 Write Timing (HAS Used)

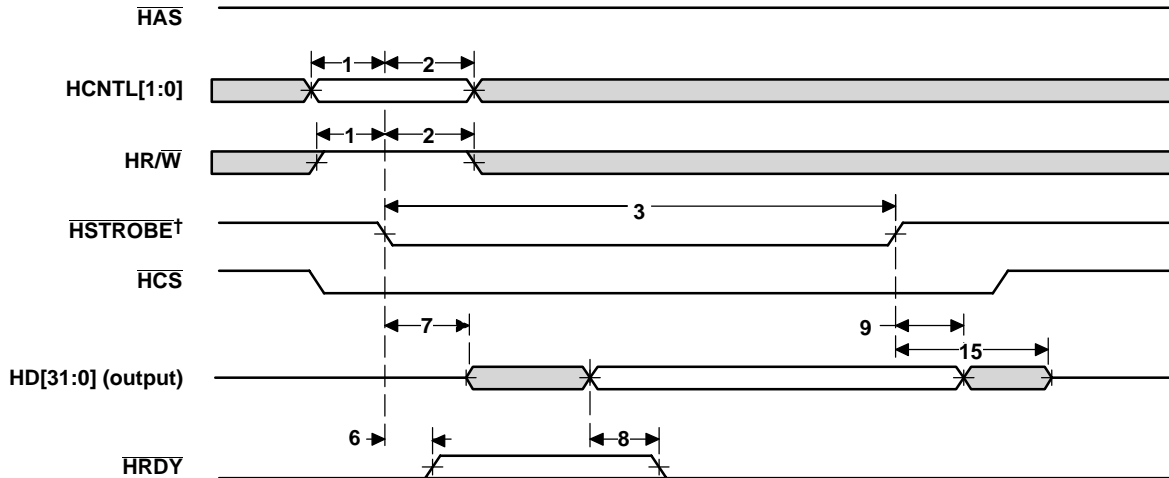

† HSTROBE refers to the following logical operation on HCS, HDS1, and HDS2: $[\text{NOT}(\text{HDS1 XOR HDS2})] \text{ OR HCS}$.

Figure 13–5. HPI32 Read Timing (HAS Not Used, Tied High)

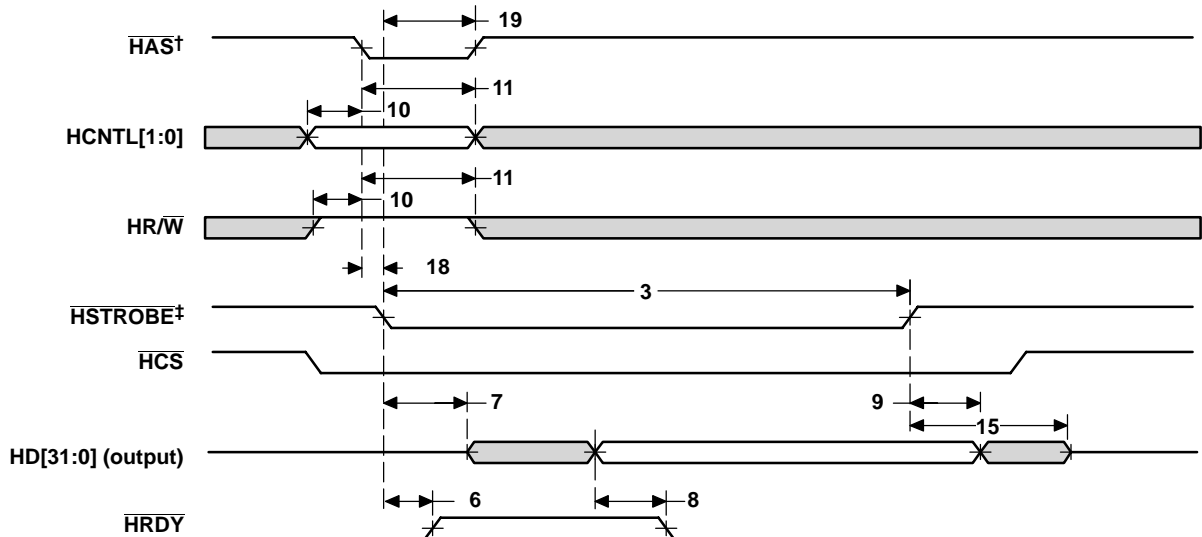

† For correct operation, strobe the HAS signal only once per HSTROBE active cycle.

‡ HSTROBE refers to the following logical operation on HCS, HDS1, and HDS2: $[\text{NOT}(\text{HDS1 XOR HDS2})] \text{ OR HCS}$.

Figure 13–6. HPI32 Read Timing (HAS Used)

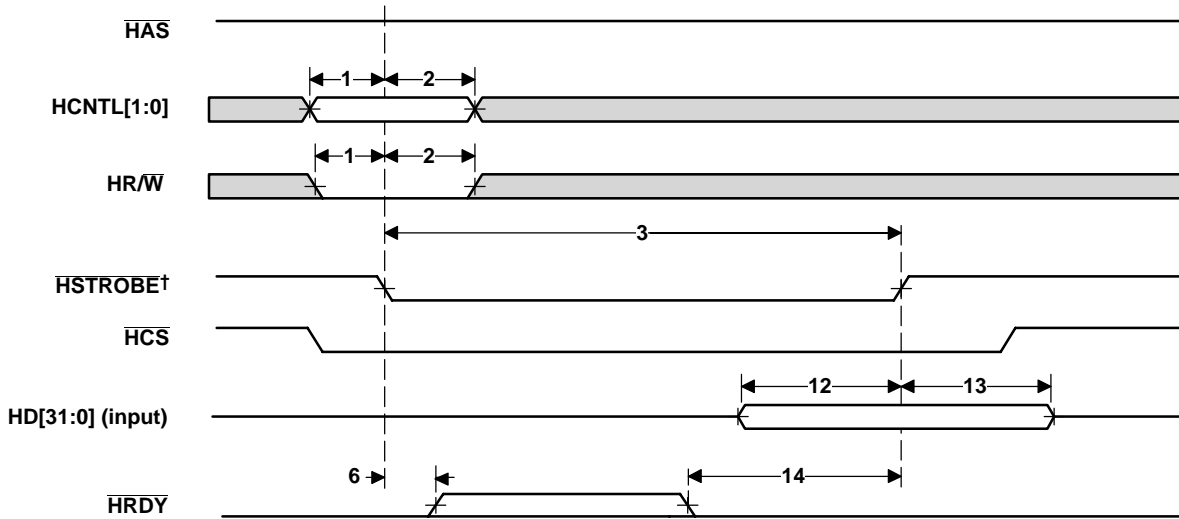

† HSTROBE refers to the following logical operation on HCS, HDS1, and HDS2: $[\text{NOT}(\text{HDS1 XOR HDS2})] \text{ OR HCS}$.

Figure 13–7. HPI32 Write Timing (HAS Not Used, Tied High)

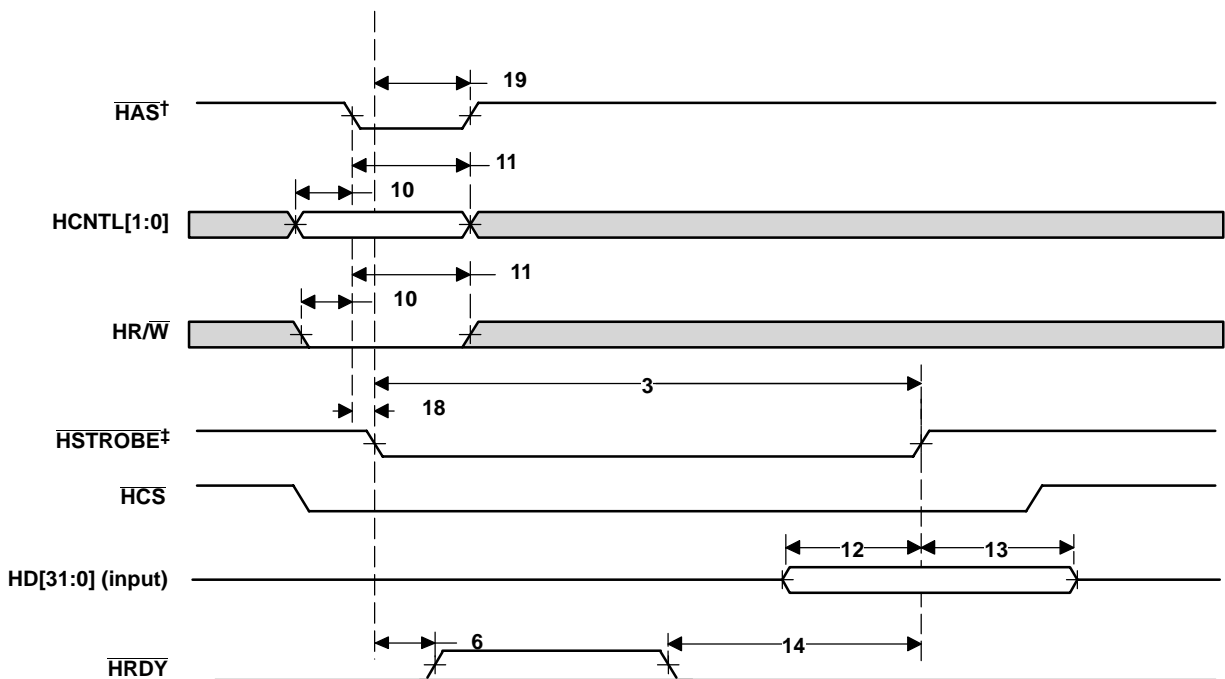

† For correct operation, strobe the HAS signal only once per HSTROBE active cycle.

‡ HSTROBE refers to the following logical operation on HCS, HDS1, and HDS2: $[\text{NOT}(\text{HDS1 XOR HDS2})] \text{ OR HCS}$.

Figure 13–8. HPI32 Write Timing (HAS Used)

14 Peripheral Component Interconnect (PCI) Timing

Table 14–1. Timing Requirements for PCLK^{†‡} (see Figure 14–1)

| NO. | | –500 [33 MHz] | | –600, –720 [66 MHz] | | UNIT |
|-----|--|--------------------|-----|---------------------|-----|------|
| | | MIN | MAX | MIN | MAX | |
| 1 | $t_{c(PCLK)}$ Cycle time, PCLK | 30 (or $4P^{\S}$) | | 15 (or $4P^{\S}$) | | ns |
| 2 | $t_{w(PCLKH)}$ Pulse duration, PCLK high | 11 | | 6 | | ns |
| 3 | $t_{w(PCLKL)}$ Pulse duration, PCLK low | 11 | | 6 | | ns |
| 4 | $t_{sr(PCLK)}$ $\Delta v/\Delta t$ slew rate, PCLK | 1 | 4 | 1.5 | 4 | V/ns |

[†] For 3.3-V operation, the reference points for the rise and fall transitions are measured at V_{ILP} MAX and V_{IHP} MIN.

[‡] $P = 1/\text{CPU clock frequency}$ in ns. For example when running parts at 600 MHz, use $P = 1.67$ ns.

[§] Select the parameter value, whichever is larger.

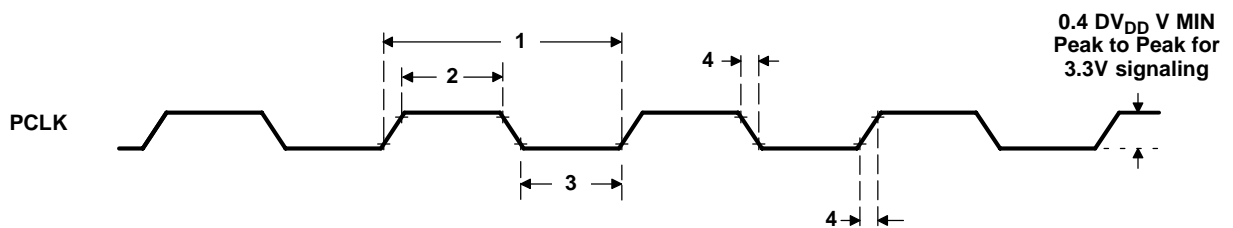

Figure 14–1. PCLK Timing

Table 14–2. Timing Requirements for PCI Reset (see Figure 14–2)

| NO. | | –500 –600 –720 | | UNIT |
|-----|---|----------------------|-----|---------------|
| | | MIN | MAX | |
| 1 | $t_{w(PRST)}$ Pulse duration, PRST | 1 | | ms |
| 2 | $t_{su(PCLKA-PRSTH)}$ Setup time, PCLK active before \overline{PRST} high | 100 | | μs |

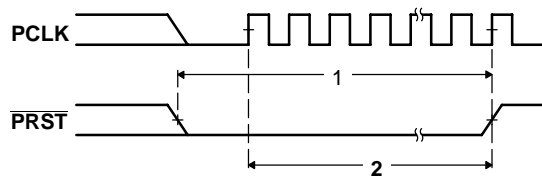

Figure 14–2. PCI Reset (\overline{PRST}) Timing

Table 14–3. Timing Requirements for PCI Inputs (see Figure 14–3)

| NO. | | –500 | | –600 –720 | | UNIT |
|-----|--------------------|--|-----|--------------|-----|------|
| | | 33 MHz | | 66 MHz | | |
| | | MIN | MAX | MIN | MAX | |
| 4 | $t_{su}(IV-PCLKH)$ | Setup time, input valid before PCLK high | | 7 | 3 | ns |
| 5 | $t_h(IV-PCLKH)$ | Hold time, input valid after PCLK high | | 0 | 0 | ns |

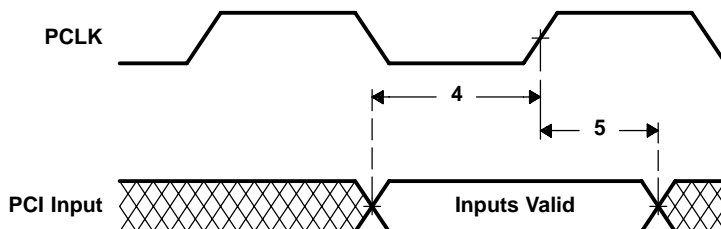

Figure 14–3. PCI Input Timing (33-/66-MHz)

Table 14–4. Switching Characteristics Over Recommended Operating Conditions for PCI Outputs (see Figure 14–4)

| NO. | PARAMETER | –500 | | –600 –720 | | UNIT | | |
|-----|------------------|--|-----|--------------|-----|------|---|----|
| | | 33 MHz | | 66 MHz | | | | |
| | | MIN | MAX | MIN | MAX | | | |
| 1 | $t_d(PCLKH-OV)$ | Delay time, PCLK high to output valid | | 2 | 11 | 2 | 6 | ns |
| 2 | $t_d(PCLKH-OLZ)$ | Delay time, PCLK high to output low impedance | | 2 | | 2 | | ns |
| 3 | $t_d(PCLKH-OHZ)$ | Delay time, PCLK high to output high impedance | | 28 | | 14 | | ns |

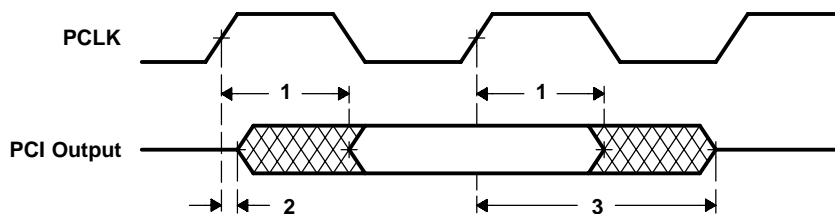

Figure 14–4. PCI Output Timing (33-/66-MHz)

Table 14–5. Timing Requirements for Serial EEPROM Interface (see Figure 14–5)

| NO. | | | -500 -600 -720 | | UNIT |
|-----|--------------------|--|----------------------|-----|------|
| | | | MIN | MAX | |
| 8 | $t_{su}(DIV-CLKH)$ | Setup time, XSP_DI valid before XSP_CLK high | 50 | | ns |
| 9 | $t_h(CLKH-DIV)$ | Hold time, XSP_DI valid after XSP_CLK high | 0 | | ns |

Table 14–6. Switching Characteristics Over Recommended Operating Conditions for Serial EEPROM Interface[†] (see Figure 14–5)

| NO. | PARAMETER | -500 -600 -720 | | | UNIT |
|-----|---------------------|---|-----|-------|------|
| | | MIN | TYP | MAX | |
| 1 | $t_w(CSL)$ | Pulse duration, XSP_CS low | | 4092P | ns |
| 2 | $t_d(CLKL-CSL)$ | Delay time, XSP_CLK low to XSP_CS low | | 0 | ns |
| 3 | $t_d(CSH-CLKH)$ | Delay time, XSP_CS high to XSP_CLK high | | 2046P | ns |
| 4 | $t_w(CLKH)$ | Pulse duration, XSP_CLK high | | 2046P | ns |
| 5 | $t_w(CLKL)$ | Pulse duration, XSP_CLK low | | 2046P | ns |
| 6 | $t_{osu}(DOV-CLKH)$ | Output setup time, XSP_DO valid before XSP_CLK high | | 2046P | ns |
| 7 | $t_{oh}(CLKH-DOV)$ | Output hold time, XSP_DO valid after XSP_CLK high | | 2046P | ns |

[†] P = 1/CPU clock frequency in ns. For example, when running parts at 600 MHz, use P = 1.67 ns.

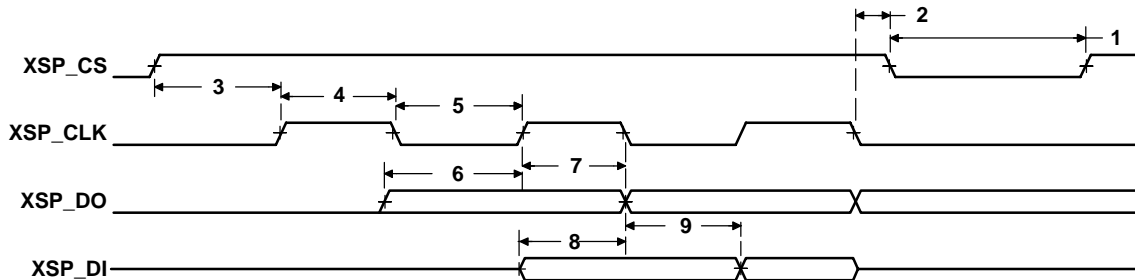

Figure 14–5. PCI Serial EEPROM Interface Timing

15 Multichannel Buffered Serial Port (McBSP) Timing

Table 15–1. Timing Requirements for McBSP† (see Figure 15–1)

| NO. | | | -500 -600 -720 | | UNIT |
|-----|--------------------|---|----------------------|--------------------------------|------|
| | | | MIN | MAX | |
| 2 | $t_{c(CKRX)}$ | Cycle time, CLKR/X | CLKR/X ext | 4P or 6.67‡§ | ns |
| 3 | $t_{w(CKRX)}$ | Pulse duration, CLKR/X high or CLKR/X low | CLKR/X ext | $0.5t_{c(CKRX)} - 1^{\dagger}$ | ns |
| 5 | $t_{su(FRH-CKRL)}$ | Setup time, external FSR high before CLKR low | CLKR int | 9 | ns |
| | | | CLKR ext | 1.3 | |
| 6 | $t_{h(CKRL-FRH)}$ | Hold time, external FSR high after CLKR low | CLKR int | 6 | ns |
| | | | CLKR ext | 3 | |
| 7 | $t_{su(DRV-CKRL)}$ | Setup time, DR valid before CLKR low | CLKR int | 8 | ns |
| | | | CLKR ext | 0.9 | |
| 8 | $t_{h(CKRL-DRV)}$ | Hold time, DR valid after CLKR low | CLKR int | 3 | ns |
| | | | CLKR ext | 3.1 | |
| 10 | $t_{su(FXH-CKXL)}$ | Setup time, external FSX high before CLKX low | CLKX int | 9 | ns |
| | | | CLKX ext | 1.3 | |
| 11 | $t_{h(CKXL-FXH)}$ | Hold time, external FSX high after CLKX low | CLKX int | 6 | ns |
| | | | CLKX ext | 3 | |

† CLKRP = CLKXP = FSRP = FSXP = 0. If polarity of any of the signals is inverted, then the timing references of that signal are also inverted.

‡ P = 1/CPU clock frequency in ns. For example, when running parts at 600 MHz, use P = 1.67 ns.

§ Minimum CLKR/X cycle times *must* be met, even when CLKR/X is generated by an internal clock source. The minimum CLKR/X cycle times are based on internal logic speed; the maximum usable speed may be lower due to EDMA limitations and AC timing requirements.

¶ This parameter applies to the maximum McBSP frequency. Operate serial clocks (CLKR/X) in the reasonable range of 40/60 duty cycle.

Table 15–2. Switching Characteristics Over Recommended Operating Conditions for McBSP†‡

| NO. | PARAMETER | | –500 –600 –720 | | UNIT | |
|-----|----------------------|--|----------------------|-----------------------------|-----------|----|
| | | | MIN | MAX | | |
| 1 | $t_{d(CKSH-CKRXH)}$ | Delay time, CLKS high to CLKR/X high for internal CLKR/X generated from CLKS input | | 1.4 | 10 | ns |
| 2 | $t_c(CKRX)$ | Cycle time, CLKR/X | CLKR/X int | 4P or 6.67 $\frac{S}{P}$ ‡# | | ns |
| 3 | $t_w(CKRX)$ | Pulse duration, CLKR/X high or CLKR/X low | CLKR/X int | C – 1 | C + 1 | ns |
| 4 | $t_{d(CKRH-FRV)}$ | Delay time, CLKR high to internal FSR valid | CLKR int | –2.1 | 3 | ns |
| 9 | $t_{d(CKXH-FXV)}$ | Delay time, CLKX high to internal FSX valid | CLKX int | –1.7 | 3 | ns |
| | | | CLKX ext | 1.7 | 9 | |
| 12 | $t_{dis(CKXH-DXHZ)}$ | Disable time, DX high impedance following last data bit from CLKX high | CLKX ext | –3.9 | 4 | ns |
| | | | | –2.1 | 9 | |
| 13 | $t_{d(CKXH-DXV)}$ | Delay time, CLKX high to DX valid | CLKX int | –3.9 + D1★ | 4 + D2★ | ns |
| | | | CLKX ext | –2.1 + D1★ | 9 + D2★ | |
| 14 | $t_{d(FXH-DXV)}$ | Delay time, FSX high to DX valid ONLY applies when in data delay 0 (XDATDLY = 00b) mode | FSX int | –2.3 + D1□ | 5.6 + D2□ | ns |
| | | | FSX ext | 1.9 + D1□ | 9 + D2□ | |

† CLKRP = CLKXP = FSRP = FSXP = 0. If polarity of any of the signals is inverted, then the timing references of that signal are also inverted.

‡ Minimum delay times also represent minimum output hold times.

§ Use whichever value is greater. Minimum CLKR/X cycle times *must* be met, even when CLKR/X is generated by an internal clock source. The minimum CLKR/X cycle times are based on internal logic speed; the maximum usable speed may be lower due to EDMA limitations and AC timing requirements.

¶ P = 1/CPU clock frequency in ns. For example, when running parts at 600 MHz, use P = 1.67 ns.

|| C = H or L

S = sample rate generator input clock = 4P if CLKSM = 1 (P = 1/CPU clock frequency)

= sample rate generator input clock = P_clks if CLKSM = 0 (P_clks = CLKS period)

H = CLKX high pulse width = (CLKGDV/2 + 1) * S if CLKGDV is even
= (CLKGDV + 1)/2 * S if CLKGDV is odd or zero

L = CLKX low pulse width = (CLKGDV/2) * S if CLKGDV is even
= (CLKGDV + 1)/2 * S if CLKGDV is odd or zero

CLKGDV should be set appropriately to ensure the McBSP bit rate does not exceed the maximum limit (see ¶ footnote above).

* Extra delay from CLKX high to DX valid **applies only to the first data bit of a device**, if and only if DXENA = 1 in SPCR.

if DXENA = 0, then D1 = D2 = 0

if DXENA = 1, then D1 = 4P, D2 = 8P

□ Extra delay from FSX high to DX valid **applies only to the first data bit of a device**, if and only if DXENA = 1 in SPCR.

if DXENA = 0, then D1 = D2 = 0

if DXENA = 1, then D1 = 4P, D2 = 8P

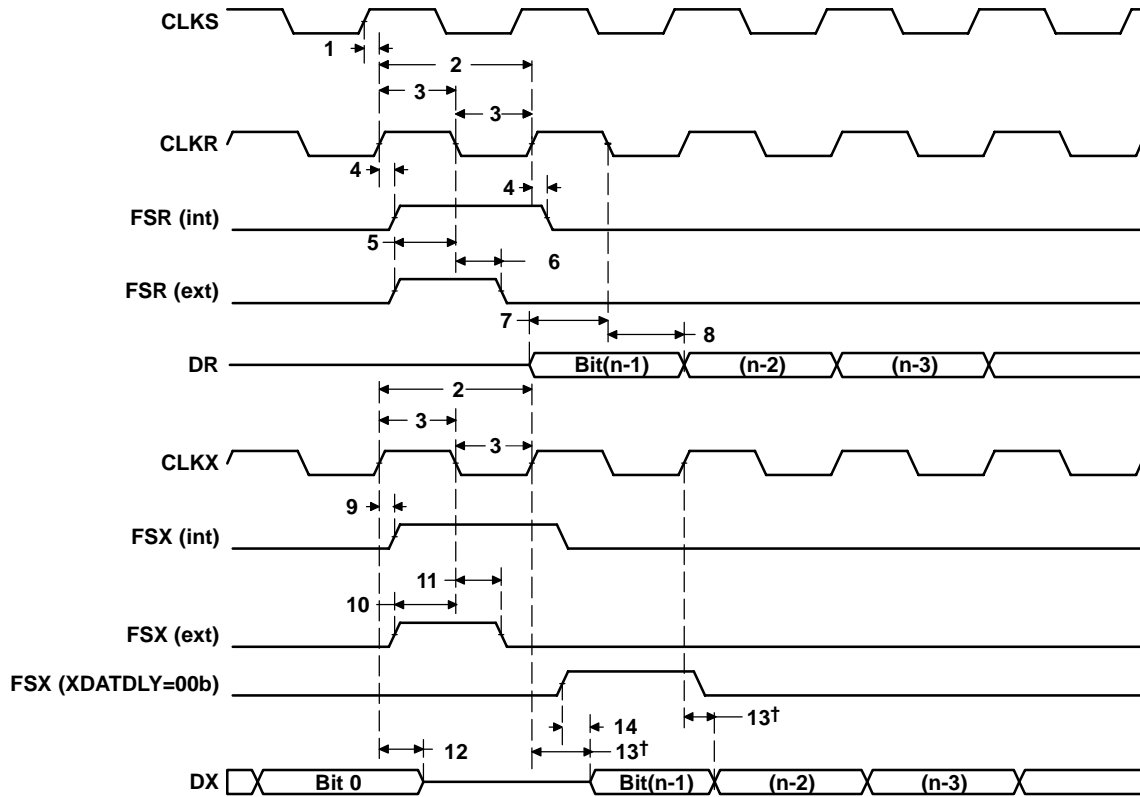

† Parameter No. 13 applies to the first data bit *only* when XDATDLY ≠ 0.

Figure 15–1. McBSP Timing

Table 15–3. Timing Requirements for FSR When GSYNC = 1 (see Figure 15–2)

| NO. | | -500 -600 -720 | | UNIT |
|-----|--|----------------------|-----|------|
| | | MIN | MAX | |
| 1 | $t_{su}(FRH-CKSH)$ Setup time, FSR high before CLKS high | 4 | | ns |
| 2 | $t_h(CKSH-FRH)$ Hold time, FSR high after CLKS high | 4 | | ns |

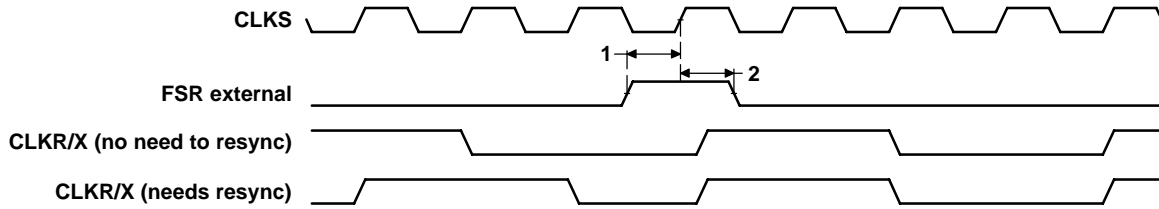

Figure 15–2. FSR Timing When GSYNC = 1

**Table 15–4. Timing Requirements for McBSP as SPI Master or Slave:
CLKSTP = 10b, CLKXP = 0†‡ (see Figure 15–3)**

| NO. | | –500, –600 –720 | | | | UNIT |
|-----|---|--------------------|-----|---------|-----|------|
| | | MASTER | | SLAVE | | |
| | | MIN | MAX | MIN | MAX | |
| 4 | $t_{su}(DRV-CKXL)$ Setup time, DR valid before CLKX low | 12 | | 2 – 12P | ns | |
| 5 | $t_h(CKXL-DRV)$ Hold time, DR valid after CLKX low | 4 | | 5 + 24P | ns | |

† P = 1/CPU clock frequency in ns. For example, when running parts at 600 MHz, use P = 1.67 ns.

‡ For all SPI Slave modes, CLKG is programmed as 1/4 of the CPU clock by setting CLKSM = CLKGDV = 1.

**Table 15–5. Switching Characteristics Over Recommended Operating Conditions for McBSP as
SPI Master or Slave: CLKSTP = 10b, CLKXP = 0†‡ (see Figure 15–3)**

| NO. | PARAMETER | –500, –600 –720 | | | | UNIT |
|-----|--|--------------------|-------|-----------|----------|------|
| | | MASTER§ | | SLAVE | | |
| | | MIN | MAX | MIN | MAX | |
| 1 | $t_h(CKXL-FXL)$ Hold time, FSX low after CLKX low¶ | T – 2 | T + 3 | | ns | |
| 2 | $t_d(FXL-CKXH)$ Delay time, FSX low to CLKX high# | L – 2.5 | L + 3 | | ns | |
| 3 | $t_d(CKXH-DXV)$ Delay time, CLKX high to DX valid | –2 | 4 | 12P + 2.8 | 20P + 17 | ns |
| 6 | $t_{dis}(CKXL-DXHZ)$ Disable time, DX high impedance following last data bit from CLKX low | L – 2 | L + 3 | | ns | |
| 7 | $t_{dis}(FXH-DXHZ)$ Disable time, DX high impedance following last data bit from FSX high | | | 4P + 3 | 12P + 17 | ns |
| 8 | $t_d(FXL-DXV)$ Delay time, FSX low to DX valid | | | 8P + 1.8 | 16P + 17 | ns |

† P = 1/CPU clock frequency in ns. For example, when running parts at 600 MHz, use P = 1.67 ns.

‡ For all SPI Slave modes, CLKG is programmed as 1/4 of the CPU clock by setting CLKSM = CLKGDV = 1.

§ S = Sample rate generator input clock = 4P if CLKSM = 1 (P = 1/CPU clock frequency)

= Sample rate generator input clock = P_clks if CLKSM = 0 (P_clks = CLKS period)

T = CLKX period = (1 + CLKGDV) * S

H = CLKX high pulse width = (CLKGDV/2 + 1) * S if CLKGDV is even

= (CLKGDV + 1)/2 * S if CLKGDV is odd or zero

L = CLKX low pulse width = (CLKGDV/2) * S if CLKGDV is even

= (CLKGDV + 1)/2 * S if CLKGDV is odd or zero

¶ FSRP = FSXP = 1. As a SPI Master, FSX is inverted to provide active-low slave-enable output. As a Slave, the active-low signal input on FSX and FSR is inverted before being used internally.

CLKXM = FSXM = 1, CLKRM = FSRM = 0 for Master McBSP

CLKXM = CLKRM = FSXM = FSRM = 0 for Slave McBSP

FSX should be low before the rising edge of clock to enable Slave devices and then begin a SPI transfer at the rising edge of the Master clock (CLKX).

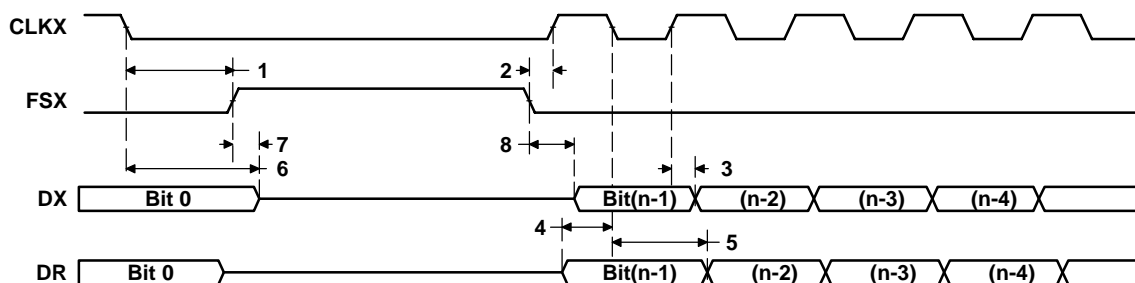

Figure 15–3. McBSP Timing as SPI Master or Slave: CLKSTP = 10b, CLKXP = 0

**Table 15–6. Timing Requirements for McBSP as SPI Master or Slave:
CLKSTP = 11b, CLKXP = 0†‡ (see Figure 15–4)**

| NO. | | -500 -600 -720 | | | | UNIT |
|-----|--|----------------------|-----|---------|-----|------|
| | | MASTER | | SLAVE | | |
| | | MIN | MAX | MIN | MAX | |
| 4 | $t_{su}(DRV-CKXH)$ Setup time, DR valid before CLKX high | 12 | | 2 – 12P | ns | |
| 5 | $t_h(CKXH-DRV)$ Hold time, DR valid after CLKX high | 4 | | 5 + 24P | ns | |

† P = 1/CPU clock frequency in ns. For example, when running parts at 600 MHz, use P = 1.67 ns.

‡ For all SPI Slave modes, CLKG is programmed as 1/4 of the CPU clock by setting CLKSM = CLKGDV = 1.

**Table 15–7. Switching Characteristics Over Recommended Operating Conditions for McBSP as
SPI Master or Slave: CLKSTP = 11b, CLKXP = 0†‡ (see Figure 15–4)**

| NO. | PARAMETER | -500 -600 -720 | | | | UNIT |
|-----|--|----------------------|-------|------------------|-----|------|
| | | MASTER§ | | SLAVE | | |
| | | MIN | MAX | MIN | MAX | |
| 1 | $t_h(CKXL-FXL)$ Hold time, FSX low after CLKX low¶ | L – 2 | L + 3 | | ns | |
| 2 | $t_d(FXL-CKXH)$ Delay time, FSX low to CLKX high# | T – 2.5 | T + 3 | | ns | |
| 3 | $t_d(CKXL-DXV)$ Delay time, CLKX low to DX valid | -2 | 4 | 12P + 3 20P + 17 | ns | |
| 6 | $t_{dis}(CKXL-DXHZ)$ Disable time, DX high impedance following last data bit from CLKX low | -2 | 4 | 12P + 3 20P + 17 | ns | |
| 7 | $t_d(FXL-DXV)$ Delay time, FSX low to DX valid | H – 2 | H + 4 | 8P + 2 16P + 17 | ns | |

† P = 1/CPU clock frequency in ns. For example, when running parts at 600 MHz, use P = 1.67 ns.

‡ For all SPI Slave modes, CLKG is programmed as 1/4 of the CPU clock by setting CLKSM = CLKGDV = 1.

§ S = Sample rate generator input clock = 4P if CLKSM = 1 (P = 1/CPU clock frequency)

= Sample rate generator input clock = P_clks if CLKSM = 0 (P_clks = CLKS period)

T = CLKX period = (1 + CLKGDV) * S

H = CLKX high pulse width = (CLKGDV/2 + 1) * S if CLKGDV is even
= (CLKGDV + 1)/2 * S if CLKGDV is odd or zero

L = CLKX low pulse width = (CLKGDV/2) * S if CLKGDV is even
= (CLKGDV + 1)/2 * S if CLKGDV is odd or zero

¶ FSRP = FSXP = 1. As a SPI Master, FSX is inverted to provide active-low slave-enable output. As a Slave, the active-low signal input on FSX and FSR is inverted before being used internally.

CLKXM = FSXM = 1, CLKRM = FSRM = 0 for Master McBSP

CLKXM = CLKRM = FSXM = FSRM = 0 for Slave McBSP

FSX should be low before the rising edge of clock to enable Slave devices and then begin a SPI transfer at the rising edge of the Master clock (CLKX).

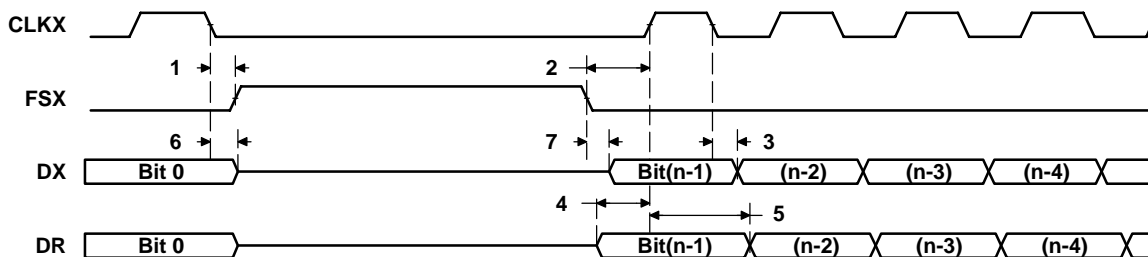

Figure 15–4. McBSP Timing as SPI Master or Slave: CLKSTP = 11b, CLKXP = 0

**Table 15–8. Timing Requirements for McBSP as SPI Master or Slave:
CLKSTP = 10b, CLKXP = 1†‡ (see Figure 15–5)**

| NO. | | –500, –600 –720 | | | | UNIT |
|-----|--|--------------------|-----|---------|-----|------|
| | | MASTER | | SLAVE | | |
| | | MIN | MAX | MIN | MAX | |
| 4 | $t_{su}(DRV-CKXH)$ Setup time, DR valid before CLKX high | 12 | | 2 – 12P | ns | |
| 5 | $t_h(CKXH-DRV)$ Hold time, DR valid after CLKX high | 4 | | 5 + 24P | ns | |

† P = 1/CPU clock frequency in ns. For example, when running parts at 600 MHz, use P = 1.67 ns.

‡ For all SPI Slave modes, CLKG is programmed as 1/4 of the CPU clock by setting CLKSM = CLKGDV = 1.

**Table 15–9. Switching Characteristics Over Recommended Operating Conditions for McBSP as
SPI Master or Slave: CLKSTP = 10b, CLKXP = 1†‡ (see Figure 15–5)**

| NO. | PARAMETER | –500, –600 –720 | | | | UNIT |
|-----|---|--------------------|-------|---------|----------|------|
| | | MASTER§ | | SLAVE | | |
| | | MIN | MAX | MIN | MAX | |
| 1 | $t_h(CKXH-FXL)$ Hold time, FSX low after CLKX high¶ | T – 2 | T + 3 | | | ns |
| 2 | $t_d(FXL-CKXL)$ Delay time, FSX low to CLKX low# | H – 2.5 | H + 3 | | | ns |
| 3 | $t_d(CKXL-DXV)$ Delay time, CLKX low to DX valid | –2 | 4 | 12P + 3 | 20P + 17 | ns |
| 6 | $t_{dis}(CKXH-DXHZ)$ Disable time, DX high impedance following last data bit from CLKX high | H – 2 | H + 3 | | | ns |
| 7 | $t_{dis}(FXH-DXHZ)$ Disable time, DX high impedance following last data bit from FSX high | | | 4P + 3 | 12P + 17 | ns |
| 8 | $t_d(FXL-DXV)$ Delay time, FSX low to DX valid | | | 8P + 2 | 16P + 17 | ns |

† P = 1/CPU clock frequency in ns. For example, when running parts at 600 MHz, use P = 1.67 ns.

‡ For all SPI Slave modes, CLKG is programmed as 1/4 of the CPU clock by setting CLKSM = CLKGDV = 1.

§ S = Sample rate generator input clock = 4P if CLKSM = 1 (P = 1/CPU clock frequency)

= Sample rate generator input clock = P_clks if CLKSM = 0 (P_clks = CLKS period)

T = CLKX period = (1 + CLKGDV) * S

H = CLKX high pulse width = (CLKGDV/2 + 1) * S if CLKGDV is even

= (CLKGDV + 1)/2 * S if CLKGDV is odd or zero

L = CLKX low pulse width = (CLKGDV/2) * S if CLKGDV is even

= (CLKGDV + 1)/2 * S if CLKGDV is odd or zero

¶ FSRP = FSXP = 1. As a SPI Master, FSX is inverted to provide active-low slave-enable output. As a Slave, the active-low signal input on FSX and FSR is inverted before being used internally.

CLKXM = FSXM = 1, CLKRM = FSRM = 0 for Master McBSP

CLKXM = CLKRM = FSXM = FSRM = 0 for Slave McBSP

FSX should be low before the rising edge of clock to enable Slave devices and then begin a SPI transfer at the rising edge of the Master clock (CLKX).

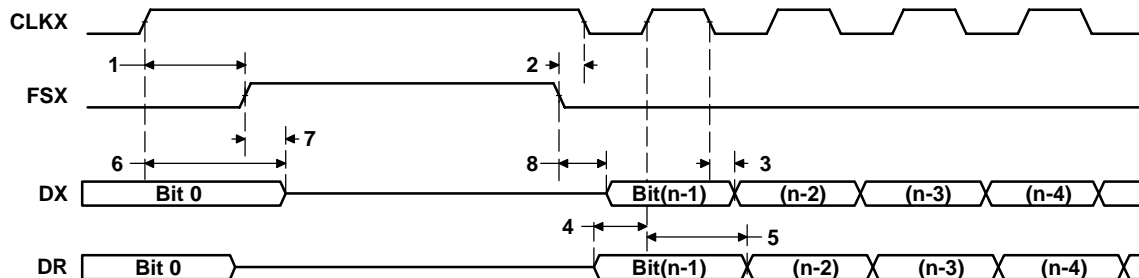

Figure 15–5. McBSP Timing as SPI Master or Slave: CLKSTP = 10b, CLKXP = 1

**Table 15–10. Timing Requirements for McBSP as SPI Master or Slave:
CLKSTP = 11b, CLKXP = 1^{†‡} (see Figure 15–6)**

| NO. | | -500 -600 -720 | | | | UNIT |
|-----|--|----------------------|-----|---------|-----|------|
| | | MASTER | | SLAVE | | |
| | | MIN | MAX | MIN | MAX | |
| 4 | $t_{su}(DRV-CKXH)$ Setup time, DR valid before CLKX high | 12 | | 2 – 12P | ns | |
| 5 | $t_h(CKXH-DRV)$ Hold time, DR valid after CLKX high | 4 | | 5 + 24P | ns | |

[†] P = 1/CPU clock frequency in ns. For example, when running parts at 600 MHz, use P = 1.67 ns.

[‡] For all SPI Slave modes, CLKG is programmed as 1/4 of the CPU clock by setting CLKSM = CLKGDV = 1.

**Table 15–11. Switching Characteristics Over Recommended Operating Conditions for McBSP as
SPI Master or Slave: CLKSTP = 11b, CLKXP = 1^{†‡} (see Figure 15–6)**

| NO. | PARAMETER | -500 -600 -720 | | | | UNIT |
|-----|---|----------------------|---------|---------|----------|------|
| | | MASTER [§] | | SLAVE | | |
| | | MIN | MAX | MIN | MAX | |
| 1 | $t_h(CKXH-FXL)$ Hold time, FSX low after CLKX high [¶] | H – 2 | H + 3 | | | ns |
| 2 | $t_d(FXL-CKXL)$ Delay time, FSX low to CLKX low [#] | T – 2.5 | T + 1.5 | | | ns |
| 3 | $t_d(CKXH-DXV)$ Delay time, CLKX high to DX valid | -2 | 4 | 12P + 3 | 20P + 17 | ns |
| 6 | $t_{dis}(CKXH-DXHZ)$ Disable time, DX high impedance following last data bit from CLKX high | -2 | 4 | 12P + 3 | 20P + 17 | ns |
| 7 | $t_d(FXL-DXV)$ Delay time, FSX low to DX valid | L – 2 | L + 4 | 8P + 2 | 16P + 17 | ns |

[†] P = 1/CPU clock frequency in ns. For example, when running parts at 600 MHz, use P = 1.67 ns.

[‡] For all SPI Slave modes, CLKG is programmed as 1/4 of the CPU clock by setting CLKSM = CLKGDV = 1.

[§] S = Sample rate generator input clock = 4P if CLKSM = 1 (P = 1/CPU clock frequency)

= Sample rate generator input clock = P_clks if CLKSM = 0 (P_clks = CLKS period)

T = CLKX period = (1 + CLKGDV) * S

H = CLKX high pulse width = (CLKGDV/2 + 1) * S if CLKGDV is even
= (CLKGDV + 1)/2 * S if CLKGDV is odd or zero

L = CLKX low pulse width = (CLKGDV/2) * S if CLKGDV is even
= (CLKGDV + 1)/2 * S if CLKGDV is odd or zero

[¶] FSRP = FSXP = 1. As a SPI Master, FSX is inverted to provide active-low slave-enable output. As a Slave, the active-low signal input on FSX and FSR is inverted before being used internally.

CLKXM = FSXM = 1, CLKRM = FSRM = 0 for Master McBSP

CLKXM = CLKRM = FSXM = FSRM = 0 for Slave McBSP

[#] FSX should be low before the rising edge of clock to enable Slave devices and then begin a SPI transfer at the rising edge of the Master clock (CLKX).

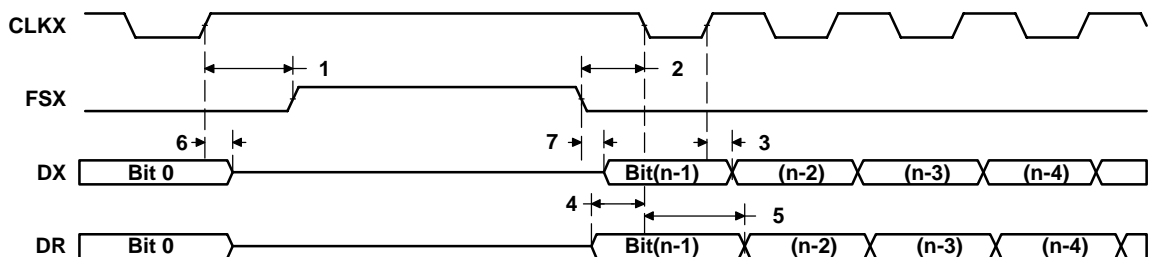

Figure 15–6. McBSP Timing as SPI Master or Slave: CLKSTP = 11b, CLKXP = 1

16 Ethernet Media Access Controller (EMAC) Timing

Table 16–1. Timing Requirements for MRCLK (see Figure 16–1)

| NO. | | -500 -600 -720 | | UNIT |
|-----|---|----------------------|-----|------|
| | | MIN | MAX | |
| 1 | $t_c(\text{MRCLK})$ Cycle time, MRCLK | 40 | | ns |
| 2 | $t_w(\text{MRCLKH})$ Pulse duration, MRCLK high | 14 | | ns |
| 3 | $t_w(\text{MRCLKL})$ Pulse duration, MRCLK low | 14 | | ns |

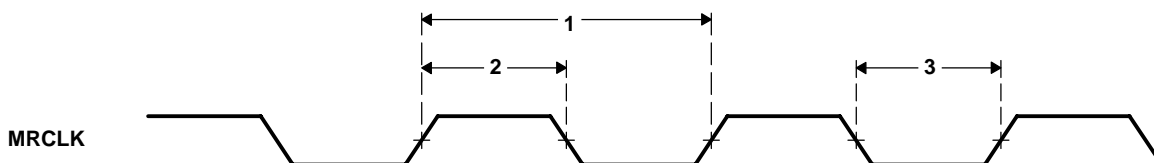

Figure 16–1. MRCLK Timing (EMAC – Receive)

Table 16–2. Timing Requirements for MTCLK (see Figure 16–1)

| NO. | | -500 -600 -720 | | UNIT |
|-----|---|----------------------|-----|------|
| | | MIN | MAX | |
| 1 | $t_c(\text{MTCLK})$ Cycle time, MTCLK | 40 | | ns |
| 2 | $t_w(\text{MTCLKH})$ Pulse duration, MTCLK high | 14 | | ns |
| 3 | $t_w(\text{MTCLKL})$ Pulse duration, MTCLK low | 14 | | ns |

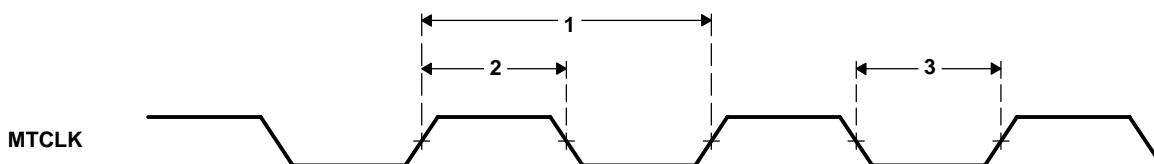

Figure 16–2. MTCLK Timing (EMAC – Transmit)

Table 16–3. Timing Requirements for EMAC MII Receive 10/100 Mbit/s† (see Figure 16–3)

| NO. | | -500 -600 -720 | | UNIT |
|-----|--|----------------------|-----|------|
| | | MIN | MAX | |
| 1 | $t_{su}(MRXD-MRCLKH)$ Setup time, receive selected signals valid before MRCLK high | 8 | | ns |
| 2 | $t_h(MRCLKH-MRXD)$ Hold time, receive selected signals valid after MRCLK high | 8 | | ns |

† Receive selected signals include: MRXD3–MRXD0, MRXDV, and MRXER.

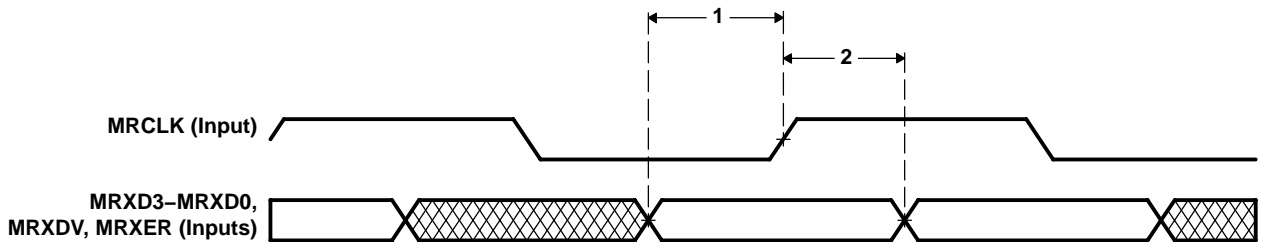

Figure 16–3. EMAC Receive Interface Timing

Table 16–4. Switching Characteristics Over Recommended Operating Conditions for EMAC MII Transmit 10/100 Mbit/s‡ (see Figure 16–4)

| NO. | | -500 -600 -720 | | UNIT |
|-----|--|----------------------|-----|------|
| | | MIN | MAX | |
| 1 | $t_d(MTCLKH-MTXD)$ Delay time, MTCLK high to transmit selected signals valid | 5 | 25 | ns |

‡ Transmit selected signals include: MTXD3–MTXD0, and MTXEN.

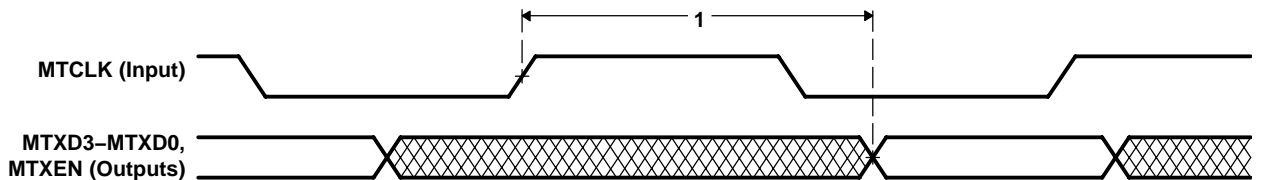

Figure 16–4. EMAC Transmit Interface Timing

17 Management Data Input/Output (MDIO) Timing

Table 17-1. Timing Requirements for MDIO Input (see Figure 17-1)

| NO. | | | -500 -600 -720 | | UNIT |
|-----|-----------------------|---|----------------------|-----|------|
| | | | MIN | MAX | |
| 1 | $t_{c(MDCLK)}$ | Cycle time, MDCLK | 400 | | ns |
| 2 | $t_{w(MDCLK)}$ | Pulse duration, MDCLK high/low | 180 | | ns |
| 3 | $t_{su(MDIO-MDCLKH)}$ | Setup time, MDIO data input valid before MDCLK high | 10 | | ns |
| 4 | $t_{h(MDCLKH-MDIO)}$ | Hold time, MDIO data input valid after MDCLK high | 0 | | ns |

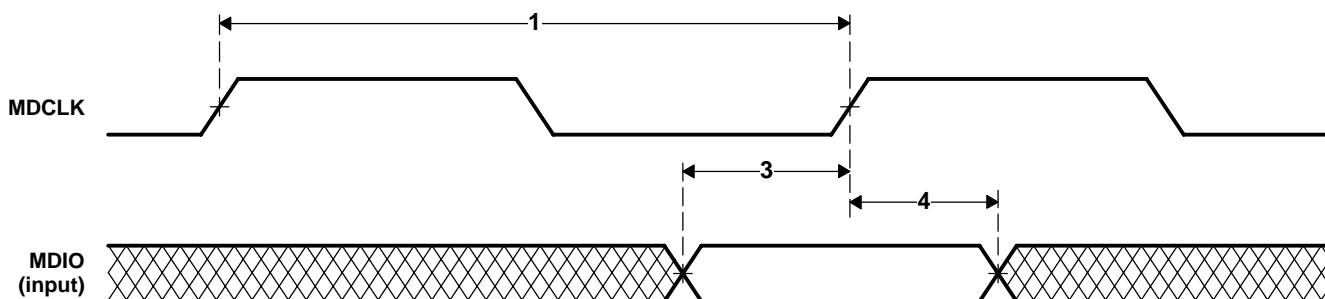

Figure 17-1. MDIO Input Timing

Table 17-2. Switching Characteristics Over Recommended Operating Conditions for MDIO Output (see Figure 17-2)

| NO. | | | -500 -600 -720 | | UNIT |
|-----|----------------------|---|----------------------|-----|------|
| | | | MIN | MAX | |
| 7 | $t_{d(MDCLKL-MDIO)}$ | Delay time, MDCLK low to MDIO data output valid | -10 | 100 | ns |

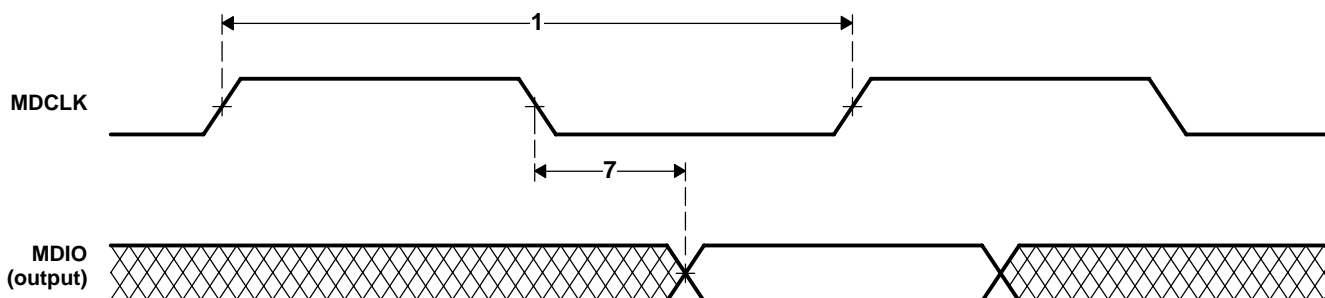

Figure 17-2. MDIO Output Timing

18 Timer Timing

Table 18–1. Timing Requirements for Timer Inputs† (see Figure 18–1)

| NO. | | | -500 -600 -720 | | UNIT |
|-----|----------------|---------------------------|----------------------|-----|------|
| | | | MIN | MAX | |
| 1 | $t_{w(TINPH)}$ | Pulse duration, TINP high | 8P | | ns |
| 2 | $t_{w(TINPL)}$ | Pulse duration, TINP low | 8P | | ns |

† P = 1/CPU clock frequency in ns. For example, when running parts at 600 MHz, use P = 1.67 ns.

Table 18–2. Switching Characteristics Over Recommended Operating Conditions for Timer Outputs† (see Figure 18–1)

| NO. | PARAMETER | -500 -600 -720 | | UNIT |
|-----|----------------|---------------------------|------|------|
| | | MIN | MAX | |
| 3 | $t_{w(TOUTH)}$ | Pulse duration, TOUT high | 8P–3 | ns |
| 4 | $t_{w(TOURL)}$ | Pulse duration, TOUT low | 8P–3 | ns |

† P = 1/CPU clock frequency in ns. For example, when running parts at 600 MHz, use P = 1.67 ns.

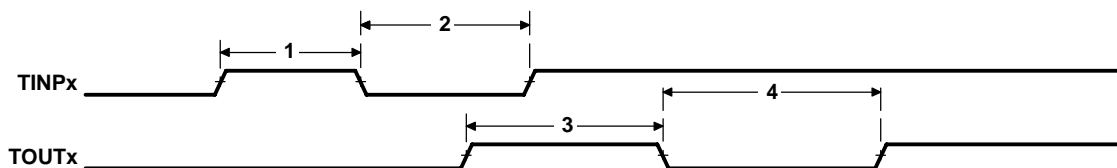

Figure 18–1. Timer Timing

19 General-Purpose Input/Output (GPIO) Port Timing

Table 19–1. Timing Requirements for GPIO Inputs^{†‡} (see Figure 19–1)

| NO. | | -500 -600 -720 | | UNIT |
|-----|---|----------------------|-----|------|
| | | MIN | MAX | |
| 1 | $t_{w(GPIH)}$ Pulse duration, GPIx high | 8P | | ns |
| 2 | $t_{w(GPIL)}$ Pulse duration, GPIx low | 8P | | ns |

[†] P = 1/CPU clock frequency in ns. For example, when running parts at 600 MHz, use P = 1.67 ns.

[‡] The pulse width given is sufficient to generate a CPU interrupt or an EDMA event. However, if a user wants to have the DSP recognize the GPIx changes through software polling of the GPIO register, the GPIx duration must be extended to at least 12P to allow the DSP enough time to access the GPIO register through the CFGBUS.

Table 19–2. Switching Characteristics Over Recommended Operating Conditions for GPIO Outputs[†] (see Figure 19–1)

| NO. | PARAMETER | -500 -600 -720 | | UNIT |
|-----|---|----------------------|-----|------|
| | | MIN | MAX | |
| 3 | $t_{w(GPOH)}$ Pulse duration, GPOx high | 24P – 8 [‡] | | ns |
| 4 | $t_{w(GPOL)}$ Pulse duration, GPOx low | 24P – 8 [‡] | | ns |

[†] P = 1/CPU clock frequency in ns. For example, when running parts at 600 MHz, use P = 1.67 ns.

[‡] This parameter value should not be used as a maximum performance specification. Actual performance of back-to-back accesses of the GPIO is dependent upon internal bus activity.

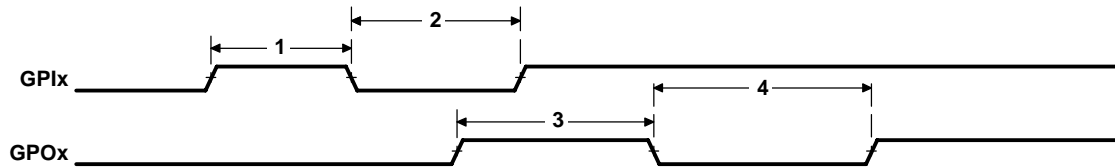

Figure 19–1. GPIO Port Timing

20 JTAG Test-Port Timing

Table 20–1. Timing Requirements for JTAG Test Port (see Figure 20–1)

| NO. | | -500 -600 -720 | | UNIT |
|-----|--|----------------------|-----|------|
| | | MIN | MAX | |
| 1 | $t_c(\text{TCK})$ Cycle time, TCK | 35 | | ns |
| 3 | $t_{su}(\text{TDIV-TCKH})$ Setup time, TDI/TMS/ $\overline{\text{TRST}}$ valid before TCK high | 10 | | ns |
| 4 | $t_h(\text{TCKH-TDIV})$ Hold time, TDI/TMS/ $\overline{\text{TRST}}$ valid after TCK high | 9 | | ns |

Table 20–2. Switching Characteristics Over Recommended Operating Conditions for JTAG Test Port (see Figure 20–1)

| NO. | PARAMETER | -500 -600 -720 | | UNIT |
|-----|--|----------------------|-----|------|
| | | MIN | MAX | |
| 2 | $t_d(\text{TCKL-TDOV})$ Delay time, TCK low to TDO valid | 0 | 18 | ns |

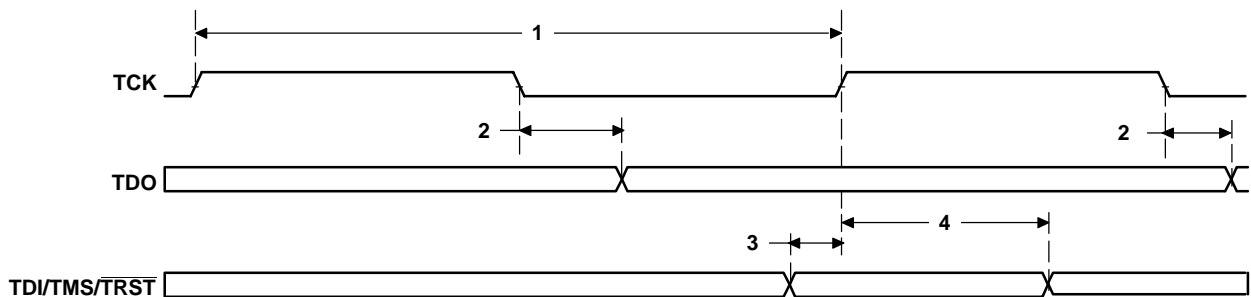

Figure 20–1. JTAG Test-Port Timing

21 Mechanical Data

21.1 Thermal Data

The following tables show the thermal resistance characteristics for the GDK, ZDK, GNZ and ZNZ mechanical packages.

Table 21–1. Thermal Resistance Characteristics (S-PBGA Package) [GDK]

| NO | | °C/W | Air Flow (m/s†) |
|----|--------------------------------------|------|-----------------|
| 1 | R θ_{JC} Junction-to-case | 3.3 | N/A |
| 2 | R θ_{JB} Junction-to-board | 7.92 | N/A |
| 3 | R θ_{JA} Junction-to-free air | 18.2 | 0.00 |
| 4 | | 15.3 | 0.5 |
| 5 | | 13.7 | 1.0 |
| 6 | | 12.2 | 2.00 |
| 7 | Psi $_{JT}$ Junction-to-package top | 0.37 | 0.00 |
| 8 | | 0.47 | 0.5 |
| 9 | | 0.57 | 1.0 |
| 10 | | 0.7 | 2.00 |
| 11 | Psi $_{JB}$ Junction-to-board | 11.4 | 0.00 |
| 12 | | 11 | 0.5 |
| 13 | | 10.7 | 1.0 |
| 14 | | 10.2 | 2.00 |

† m/s = meters per second

Table 21–2. Thermal Resistance Characteristics (S-PBGA Package) [ZDK]

| NO | | °C/W | Air Flow (m/s†) |
|----|--------------------------------------|------|-----------------|
| 1 | R θ_{JC} Junction-to-case | 3.3 | N/A |
| 2 | R θ_{JB} Junction-to-board | 7.92 | N/A |
| 3 | R θ_{JA} Junction-to-free air | 18.2 | 0.00 |
| 4 | | 15.3 | 0.5 |
| 5 | | 13.7 | 1.0 |
| 6 | | 12.2 | 2.00 |
| 7 | Psi $_{JT}$ Junction-to-package top | 0.37 | 0.00 |
| 8 | | 0.47 | 0.5 |
| 9 | | 0.57 | 1.0 |
| 10 | | 0.7 | 2.00 |
| 11 | Psi $_{JB}$ Junction-to-board | 11.4 | 0.00 |
| 12 | | 11 | 0.5 |
| 13 | | 10.7 | 1.0 |
| 14 | | 10.2 | 2.00 |

† m/s = meters per second

Table 21–3. Thermal Resistance Characteristics (S-PBGA Package) [GNZ]

| NO | | °C/W | Air Flow (m/s [†]) |
|----|--------------------------------------|------|------------------------------|
| 1 | R θ_{JC} Junction-to-case | 3.3 | N/A |
| 2 | R θ_{JB} Junction-to-board | 7.46 | N/A |
| 3 | R θ_{JA} Junction-to-free air | 17.4 | 0.00 |
| 4 | | 14.0 | 0.5 |
| 5 | | 12.3 | 1.0 |
| 6 | | 10.8 | 2.00 |
| 7 | Psi $_{JT}$ Junction-to-package top | 0.37 | 0.00 |
| 8 | | 0.47 | 0.5 |
| 9 | | 0.57 | 1.0 |
| 10 | | 0.7 | 2.00 |
| 11 | Psi $_{JB}$ Junction-to-board | 11.4 | 0.00 |
| 12 | | 11 | 0.5 |
| 13 | | 10.7 | 1.0 |
| 14 | | 10.2 | 2.00 |

† m/s = meters per second

Table 21–4. Thermal Resistance Characteristics (S-PBGA Package) [ZNZ]

| NO | | °C/W | Air Flow (m/s [†]) |
|----|--------------------------------------|------|------------------------------|
| 1 | R θ_{JC} Junction-to-case | 3.3 | N/A |
| 2 | R θ_{JB} Junction-to-board | 7.46 | N/A |
| 3 | R θ_{JA} Junction-to-free air | 17.4 | 0.00 |
| 4 | | 14.0 | 0.5 |
| 5 | | 12.3 | 1.0 |
| 6 | | 10.8 | 2.00 |
| 7 | Psi $_{JT}$ Junction-to-package top | 0.37 | 0.00 |
| 8 | | 0.47 | 0.5 |
| 9 | | 0.57 | 1.0 |
| 10 | | 0.7 | 2.00 |
| 11 | Psi $_{JB}$ Junction-to-board | 11.4 | 0.00 |
| 12 | | 11 | 0.5 |
| 13 | | 10.7 | 1.0 |
| 14 | | 10.2 | 2.00 |

† m/s = meters per second

21.2 Packaging Information

The following packaging information reflects the most current released data available for the designated device(s). This data is subject to change without notice and without revision of this document.

Figure 21–1 shows some examples of the types of C6412 package symbolization for –500 MHz and –600 MHz devices. Pin A1 is always located at the top-left corner when you can read the silkscreening/laser-etching and view the TI logo properly.

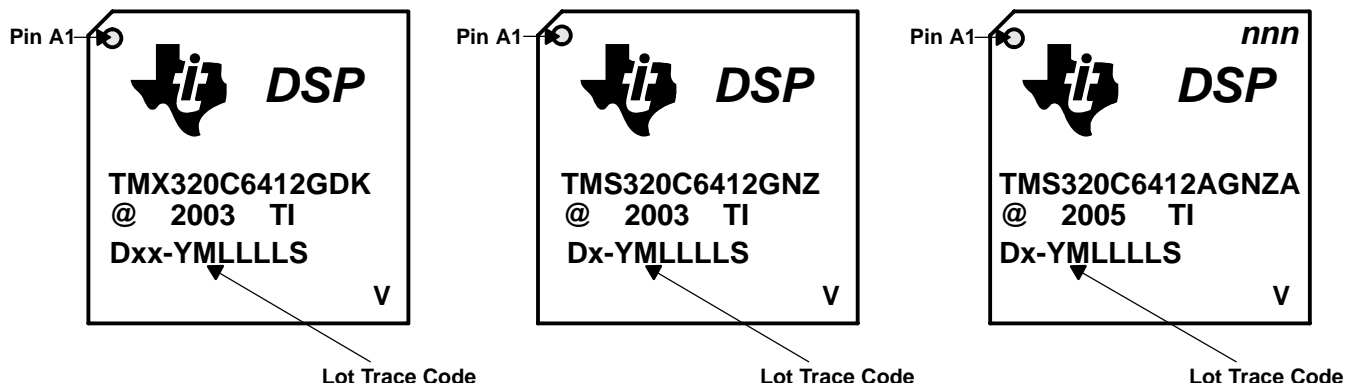

Figure 21–1. Example, Lot Trace Codes for TMX320C6412 and TMS320C6142 (GDK and GNZ Packages)

For more details on package markings, see the *TMS320C6412 Digital Signal Processor Silicon Errata* (SPRZ199).

PACKAGING INFORMATION

| Orderable Device | Status ⁽¹⁾ | Package Type | Package Drawing | Pins | Package Qty | Eco Plan ⁽²⁾ | Lead/ Ball Finish | MSL Peak Temp ⁽³⁾ | Samples (Requires Login) |
|--------------------|-----------------------|--------------|-----------------|------|-------------|--------------------------|----------------------|------------------------------|-----------------------------|
| TMS320C6412ACDK6 | OBSOLETE | FCBGA | CDK | 548 | | TBD | Call TI | Call TI | |
| TMS320C6412AGDK5 | ACTIVE | FC/CSP | GDK | 548 | 60 | TBD | SNPB | Level-4-220C-72 HR | |
| TMS320C6412AGDK6 | ACTIVE | FC/CSP | GDK | 548 | 60 | TBD | SNPB | Level-4-220C-72 HR | |
| TMS320C6412AGDK7 | ACTIVE | FC/CSP | GDK | 548 | 60 | TBD | SNPB | Level-4-220C-72 HR | |
| TMS320C6412AGDKA5 | ACTIVE | FC/CSP | GDK | 548 | 60 | TBD | SNPB | Level-4-220C-72 HR | |
| TMS320C6412AGDKA6 | ACTIVE | FC/CSP | GDK | 548 | 60 | TBD | SNPB | Level-4-220C-72 HR | |
| TMS320C6412AGNZ5 | ACTIVE | FCBGA | GNZ | 548 | 40 | TBD | SNPB | Level-4-220C-72 HR | |
| TMS320C6412AGNZ6 | ACTIVE | FCBGA | GNZ | 548 | 40 | TBD | SNPB | Level-4-220C-72 HR | |
| TMS320C6412AGNZ7 | ACTIVE | FCBGA | GNZ | 548 | 40 | TBD | SNPB | Level-4-220C-72 HR | |
| TMS320C6412AGNZA5 | ACTIVE | FCBGA | GNZ | 548 | 40 | TBD | SNPB | Level-4-220C-72 HR | |
| TMS320C6412AGNZA6 | ACTIVE | FCBGA | GNZ | 548 | 40 | TBD | SNPB | Level-4-220C-72 HR | |
| TMS320C6412AZDK5 | ACTIVE | FCBGA | ZDK | 548 | 60 | Pb-Free (RoHS Exempt) | SNAGCU | Level-4-260C-72HR | |
| TMS320C6412AZDK6 | ACTIVE | FCBGA | ZDK | 548 | 60 | Pb-Free (RoHS Exempt) | Call TI | Level-4-260C-72HR | |
| TMS320C6412AZDK7 | ACTIVE | FCBGA | ZDK | 548 | 60 | Pb-Free (RoHS Exempt) | Call TI | Level-4-260C-72HR | |
| TMS320C6412AZDKA5 | ACTIVE | FCBGA | ZDK | 548 | 60 | Pb-Free (RoHS Exempt) | SNAGCU | Level-4-260C-72HR | |
| TMS320C6412AZNZ5 | ACTIVE | FCBGA | ZNZ | 548 | 40 | Pb-Free (RoHS Exempt) | SNAGCU | Level-4-260C-72HR | |
| TMS320C6412AZNZ6 | ACTIVE | FCBGA | ZNZ | 548 | 40 | Pb-Free (RoHS Exempt) | SNAGCU | Level-4-260C-72HR | |
| TMS320C6412AZNZ7 | ACTIVE | FCBGA | ZNZ | 548 | 40 | Pb-Free (RoHS Exempt) | SNAGCU | Level-4-260C-72HR | |
| TMS320C6412AZNZA5 | ACTIVE | FCBGA | ZNZ | 548 | 40 | Pb-Free (RoHS Exempt) | SNAGCU | Level-4-260C-72HR | |
| TMS320C6412GDK500 | OBSOLETE | FC/CSP | GDK | 548 | | TBD | Call TI | Call TI | |
| TMS320C6412GDK600 | OBSOLETE | FC/CSP | GDK | 548 | | TBD | Call TI | Call TI | |
| TMS320C6412GDK720 | OBSOLETE | FC/CSP | GDK | 548 | | TBD | Call TI | Call TI | |
| TMS320C6412GDKA500 | OBSOLETE | FC/CSP | GDK | 548 | | TBD | Call TI | Call TI | |
| TMS320C6412GNZ500 | OBSOLETE | FCBGA | GNZ | 548 | | TBD | Call TI | Call TI | |

| Orderable Device | Status ⁽¹⁾ | Package Type | Package Drawing | Pins | Package Qty | Eco Plan ⁽²⁾ | Lead/ Ball Finish | MSL Peak Temp ⁽³⁾ | Samples (Requires Login) |
|--------------------|-----------------------|--------------|-----------------|------|-------------|-------------------------|----------------------|------------------------------|-----------------------------|
| TMS320C6412GNZ600 | OBSOLETE | FCBGA | GNZ | 548 | | TBD | Call TI | Call TI | |
| TMS320C6412GNZ720 | OBSOLETE | FCBGA | GNZ | 548 | | TBD | Call TI | Call TI | |
| TMS320C6412GNZA500 | OBSOLETE | FCBGA | GNZ | 548 | | TBD | Call TI | Call TI | |
| TMS320C6412ZDK500 | OBSOLETE | FCBGA | ZDK | 548 | | TBD | Call TI | Call TI | |
| TMS320C6412ZDK600 | OBSOLETE | FCBGA | ZDK | 548 | | TBD | Call TI | Call TI | |
| TMS320C6412ZDKA500 | OBSOLETE | FCBGA | ZDK | 548 | | TBD | Call TI | Call TI | |
| TMS320C6412ZNZ500 | OBSOLETE | FCBGA | ZNZ | 548 | | TBD | Call TI | Call TI | |
| TMS320C6412ZNZ600 | OBSOLETE | FCBGA | ZNZ | 548 | | TBD | Call TI | Call TI | |
| TMX320C6412GDK | OBSOLETE | FC/CSP | GDK | 548 | | TBD | Call TI | Call TI | |

⁽¹⁾ The marketing status values are defined as follows:

ACTIVE: Product device recommended for new designs.

LIFEBUY: TI has announced that the device will be discontinued, and a lifetime-buy period is in effect.

NRND: Not recommended for new designs. Device is in production to support existing customers, but TI does not recommend using this part in a new design.

PREVIEW: Device has been announced but is not in production. Samples may or may not be available.

OBSOLETE: TI has discontinued the production of the device.

⁽²⁾ Eco Plan - The planned eco-friendly classification: Pb-Free (RoHS), Pb-Free (RoHS Exempt), or Green (RoHS & no Sb/Br) - please check <http://www.ti.com/productcontent> for the latest availability information and additional product content details.

TBD: The Pb-Free/Green conversion plan has not been defined.

Pb-Free (RoHS): TI's terms "Lead-Free" or "Pb-Free" mean semiconductor products that are compatible with the current RoHS requirements for all 6 substances, including the requirement that lead not exceed 0.1% by weight in homogeneous materials. Where designed to be soldered at high temperatures, TI Pb-Free products are suitable for use in specified lead-free processes.

Pb-Free (RoHS Exempt): This component has a RoHS exemption for either 1) lead-based flip-chip solder bumps used between the die and package, or 2) lead-based die adhesive used between the die and leadframe. The component is otherwise considered Pb-Free (RoHS compatible) as defined above.

Green (RoHS & no Sb/Br): TI defines "Green" to mean Pb-Free (RoHS compatible), and free of Bromine (Br) and Antimony (Sb) based flame retardants (Br or Sb do not exceed 0.1% by weight in homogeneous material)

⁽³⁾ MSL, Peak Temp. -- The Moisture Sensitivity Level rating according to the JEDEC industry standard classifications, and peak solder temperature.

Important Information and Disclaimer: The information provided on this page represents TI's knowledge and belief as of the date that it is provided. TI bases its knowledge and belief on information provided by third parties, and makes no representation or warranty as to the accuracy of such information. Efforts are underway to better integrate information from third parties. TI has taken and continues to take reasonable steps to provide representative and accurate information but may not have conducted destructive testing or chemical analysis on incoming materials and chemicals. TI and TI suppliers consider certain information to be proprietary, and thus CAS numbers and other limited information may not be available for release.

In no event shall TI's liability arising out of such information exceed the total purchase price of the TI part(s) at issue in this document sold by TI to Customer on an annual basis.

GDK (S-PBGA-N548)

PLASTIC BALL GRID ARRAY

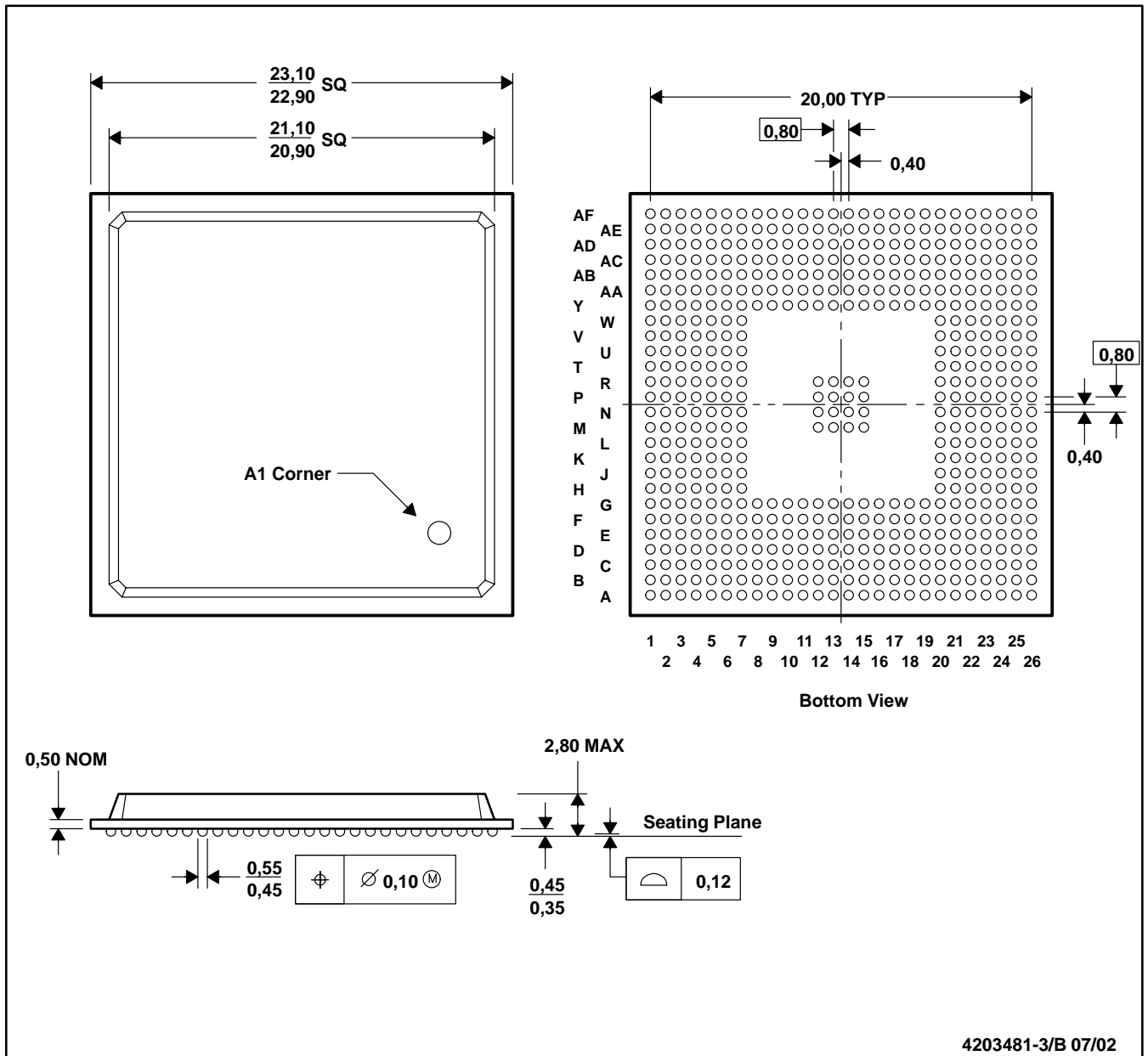

4203481-3/B 07/02

- NOTES: A. All linear dimensions are in millimeters.
 B. This drawing is subject to change without notice.
 C. Flip chip application only.

GNZ (S-PBGA-N548)

PLASTIC BALL GRID ARRAY

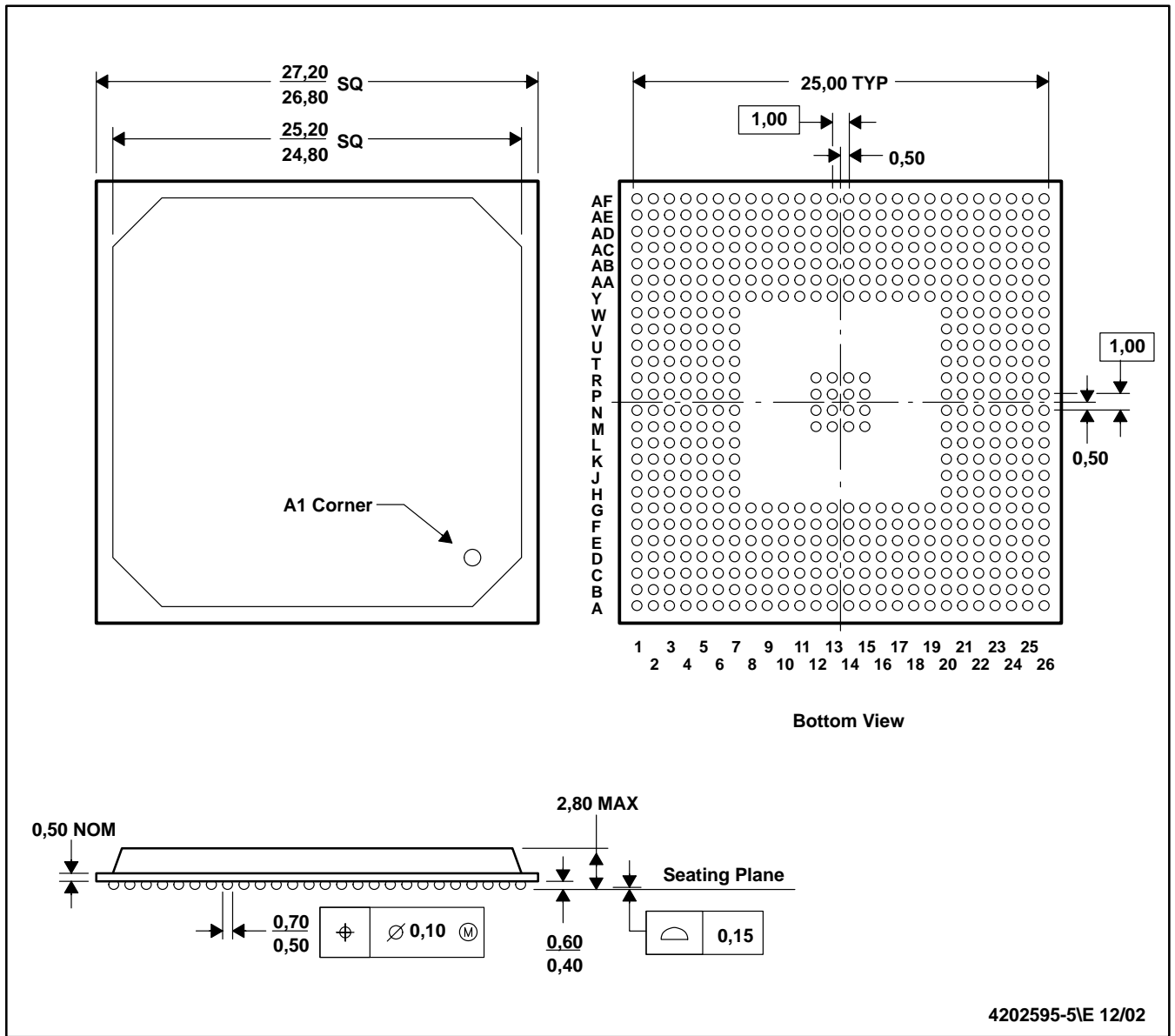

- NOTES:
- A. All linear dimensions are in millimeters.
 - B. This drawing is subject to change without notice.
 - C. Flip chip application only.
 - D. Substrate color may vary.

ZDK (S-PBGA-N548)

PLASTIC BALL GRID ARRAY

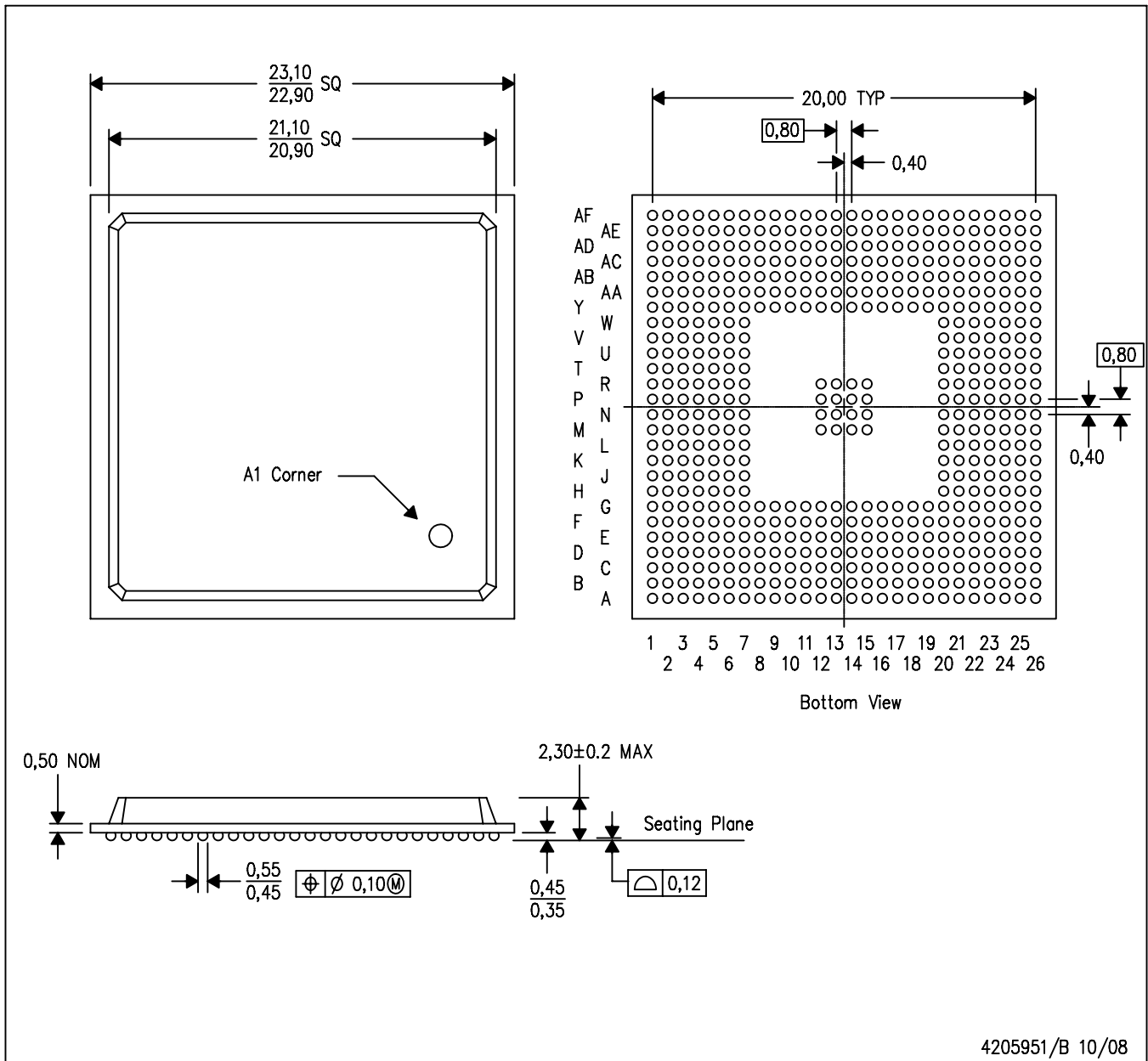

4205951/B 10/08

- NOTES:
- A. All linear dimensions are in millimeters.
 - B. This drawing is subject to change without notice.
 - C. Flip chip application only.
 - D. This package is lead-free.

ZNZ (S-PBGA-N548)

PLASTIC BALL GRID ARRAY

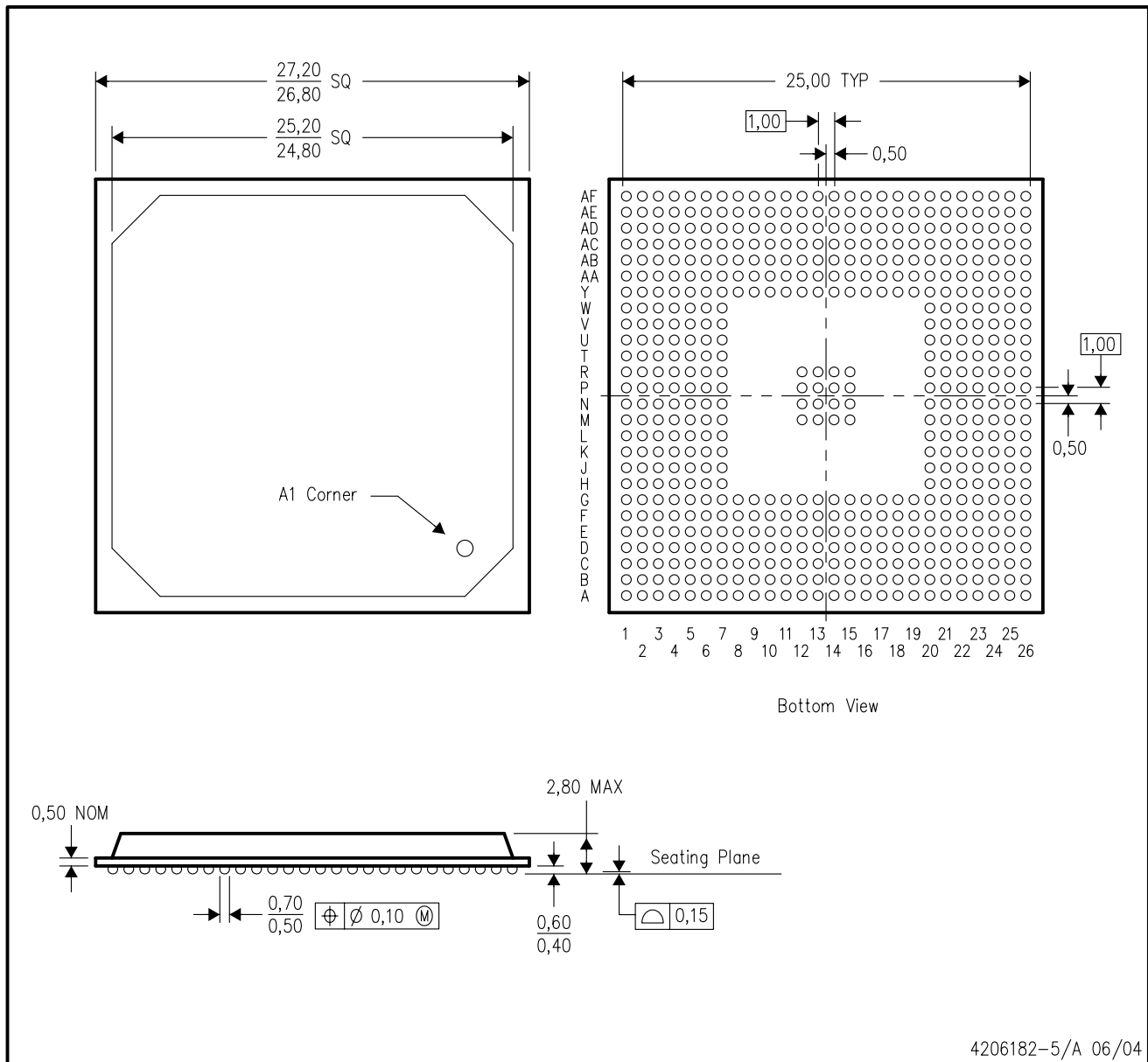

- NOTES:
- A. All linear dimensions are in millimeters.
 - B. This drawing is subject to change without notice.
 - C. Flip chip application only.
 - D. Substrate color may vary.
 - E. This package is lead-free.

IMPORTANT NOTICE

Texas Instruments Incorporated and its subsidiaries (TI) reserve the right to make corrections, modifications, enhancements, improvements, and other changes to its products and services at any time and to discontinue any product or service without notice. Customers should obtain the latest relevant information before placing orders and should verify that such information is current and complete. All products are sold subject to TI's terms and conditions of sale supplied at the time of order acknowledgment.

TI warrants performance of its hardware products to the specifications applicable at the time of sale in accordance with TI's standard warranty. Testing and other quality control techniques are used to the extent TI deems necessary to support this warranty. Except where mandated by government requirements, testing of all parameters of each product is not necessarily performed.

TI assumes no liability for applications assistance or customer product design. Customers are responsible for their products and applications using TI components. To minimize the risks associated with customer products and applications, customers should provide adequate design and operating safeguards.

TI does not warrant or represent that any license, either express or implied, is granted under any TI patent right, copyright, mask work right, or other TI intellectual property right relating to any combination, machine, or process in which TI products or services are used. Information published by TI regarding third-party products or services does not constitute a license from TI to use such products or services or a warranty or endorsement thereof. Use of such information may require a license from a third party under the patents or other intellectual property of the third party, or a license from TI under the patents or other intellectual property of TI.

Reproduction of TI information in TI data books or data sheets is permissible only if reproduction is without alteration and is accompanied by all associated warranties, conditions, limitations, and notices. Reproduction of this information with alteration is an unfair and deceptive business practice. TI is not responsible or liable for such altered documentation. Information of third parties may be subject to additional restrictions.

Resale of TI products or services with statements different from or beyond the parameters stated by TI for that product or service voids all express and any implied warranties for the associated TI product or service and is an unfair and deceptive business practice. TI is not responsible or liable for any such statements.

TI products are not authorized for use in safety-critical applications (such as life support) where a failure of the TI product would reasonably be expected to cause severe personal injury or death, unless officers of the parties have executed an agreement specifically governing such use. Buyers represent that they have all necessary expertise in the safety and regulatory ramifications of their applications, and acknowledge and agree that they are solely responsible for all legal, regulatory and safety-related requirements concerning their products and any use of TI products in such safety-critical applications, notwithstanding any applications-related information or support that may be provided by TI. Further, Buyers must fully indemnify TI and its representatives against any damages arising out of the use of TI products in such safety-critical applications.

TI products are neither designed nor intended for use in military/aerospace applications or environments unless the TI products are specifically designated by TI as military-grade or "enhanced plastic." Only products designated by TI as military-grade meet military specifications. Buyers acknowledge and agree that any such use of TI products which TI has not designated as military-grade is solely at the Buyer's risk, and that they are solely responsible for compliance with all legal and regulatory requirements in connection with such use.

TI products are neither designed nor intended for use in automotive applications or environments unless the specific TI products are designated by TI as compliant with ISO/TS 16949 requirements. Buyers acknowledge and agree that, if they use any non-designated products in automotive applications, TI will not be responsible for any failure to meet such requirements.

Following are URLs where you can obtain information on other Texas Instruments products and application solutions:

Products

| | |
|------------------------|--|
| Audio | www.ti.com/audio |
| Amplifiers | amplifier.ti.com |
| Data Converters | dataconverter.ti.com |
| DLP® Products | www.dlp.com |
| DSP | dsp.ti.com |
| Clocks and Timers | www.ti.com/clocks |
| Interface | interface.ti.com |
| Logic | logic.ti.com |
| Power Mgmt | power.ti.com |
| Microcontrollers | microcontroller.ti.com |
| RFID | www.ti-rfid.com |
| OMAP Mobile Processors | www.ti.com/omap |
| Wireless Connectivity | www.ti.com/wirelessconnectivity |

Applications

| | |
|-------------------------------|--|
| Automotive and Transportation | www.ti.com/automotive |
| Communications and Telecom | www.ti.com/communications |
| Computers and Peripherals | www.ti.com/computers |
| Consumer Electronics | www.ti.com/consumer-apps |
| Energy and Lighting | www.ti.com/energy |
| Industrial | www.ti.com/industrial |
| Medical | www.ti.com/medical |
| Security | www.ti.com/security |
| Space, Avionics and Defense | www.ti.com/space-avionics-defense |
| Video and Imaging | www.ti.com/video |

TI E2E Community Home Page

e2e.ti.com

Mailing Address: Texas Instruments, Post Office Box 655303, Dallas, Texas 75265
Copyright © 2012, Texas Instruments Incorporated