

# TLC193, TLC393 DUAL MICROPOWER LinCMOS™ VOLTAGE COMPARATOR

SLCS115E – DECEMBER 1986 – REVISED JULY 2003

- **Very Low Power . . . 110  $\mu$ W Typ at 5 V**
- **Fast Response Time . . .  $t_{PLH} = 2.5 \mu$ s Typ With 5-mV Overdrive**
- **Single Supply Operation:**
  - TLC393C . . . 3 V to 16 V
  - TLC393I . . . 3 V to 16 V
  - TLC393Q . . . 4 V to 16 V
  - TLC393M . . . 4 V to 16 V
  - TLC193M . . . 4 V to 16 V
- **On-Chip ESD Protection**

## description

The TLC193 and TLC393 consist of dual independent micropower voltage comparators designed to operate from a single supply. They are functionally similar to the LM393 but uses one-twentieth the power for similar response times. The open-drain MOS output stage interfaces to a variety of loads and supplies. For a similar device with a push-pull output configuration (see the TLC3702 data sheet).

Texas Instruments LinCMOS™ process offers superior analog performance to standard CMOS processes. Along with the standard CMOS advantages of low power without sacrificing speed, high input impedance, and low bias currents, the LinCMOS™ process offers extremely stable input offset voltages, even with differential input stresses of several volts. This characteristic makes it possible to build reliable CMOS comparators.

The TLC393C is characterized for operation over the commercial temperature range of  $T_A = 0^\circ\text{C}$  to  $70^\circ\text{C}$ . The TLC393I is characterized for operation over the extended industrial temperature range of  $T_A = -40^\circ\text{C}$  to  $85^\circ\text{C}$ . The TLC393Q is characterized for operation over the full automotive temperature range of  $T_A = -40^\circ\text{C}$  to  $125^\circ\text{C}$ . The TLC193M and TLC393M are characterized for operation over the full military temperature range of  $T_A = -55^\circ\text{C}$  to  $125^\circ\text{C}$ .

D, JG, P, OR PW PACKAGE  
(TOP VIEW)

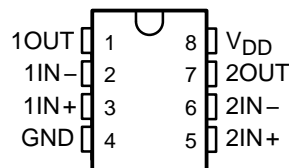

FK PACKAGE  
(TOP VIEW)

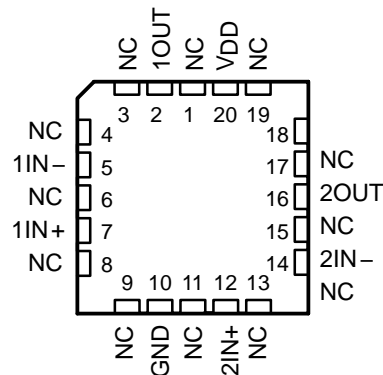

NC – No internal connection

## symbol (each comparator)

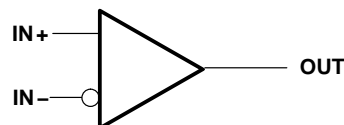

Please be aware that an important notice concerning availability, standard warranty, and use in critical applications of Texas Instruments semiconductor products and disclaimers thereto appears at the end of this data sheet.

LinCMOS is a trademark of Texas Instruments Incorporated. All other trademarks are the property of their respective owners.

PRODUCTION DATA information is current as of publication date. Products conform to specifications per the terms of Texas Instruments standard warranty. Production processing does not necessarily include testing of all parameters.

 **TEXAS  
INSTRUMENTS**

POST OFFICE BOX 655303 • DALLAS, TEXAS 75265  
POST OFFICE BOX 1443 • HOUSTON, TEXAS 77251-1443

Copyright © 1986-2003, Texas Instruments Incorporated

# TLC193, TLC393

## DUAL MICROWPOWER LinCMOS™ VOLTAGE COMPARATOR

SLCS115D – DECEMBER 1986 – REVISED JULY 2003

### AVAILABLE OPTIONS

T <sub>A</sub>	V <sub>IOmax</sub> at 25°C	PACKAGES				
		SMALL OUTLINE (D)	CHIP CARRIER (FK)	CERAMIC DIP (JG)	PLASTIC DIP (P)	TSSOP (PW)
0°C to 70°C	5 mV	TLC393CD	—	—	TLC393CP	TLC393CPWLE
– 40°C to 85°C	5 mV	TLC393ID	—	—	TLC393IP	TLC393IPWLE
– 40°C to 125°C	5 mV	TLC393QD	—	—	—	—
– 55°C to 125°C	5 mV	TLC393MD	TLC193MFK	TLC193MJG	TLC393MP	—

The D package is available taped and reeled. Add the suffix R to the device type (e.g., TLC393CDR).

### schematic

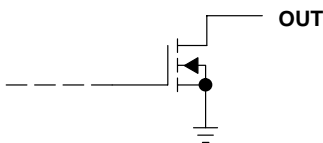

OPEN-DRAIN CMOS OUTPUT

### absolute maximum ratings over operating free-air temperature range (unless otherwise noted)†

Supply voltage range, V <sub>DD</sub> (see Note 1)	– 0.3 V to 18 V
Differential input voltage, V <sub>ID</sub> (see Note 2)	±18 V
Input voltage range, V <sub>I</sub>	– 0.3 V to V <sub>DD</sub>
Output voltage range, V <sub>O</sub>	– 0.3 V to 16 V
Input current, I <sub>I</sub>	±5 mA
Output current, I <sub>O</sub> (each output)	20 mA
Total supply current into V <sub>DD</sub>	40 mA
Total current out of GND	40 mA
Continuous total power dissipation	See Dissipation Rating Table
Operating free-air temperature range:	
TLC393C	0°C to 70°C
TLC393I	– 40°C to 85°C
TLC393Q	– 40°C to 125°C
TLC393M	– 55°C to 125°C
TLC193M	– 55°C to 125°C
Storage temperature range	– 65°C to 150°C
Case temperature for 60 seconds: FK package	260°C
Lead temperature 1,6 mm (1/16 inch) from case for 10 seconds: D or P package	260°C
Lead temperature 1,6 mm (1/16 inch) from case for 60 seconds: JG package	300°C

† Stresses beyond those listed under “absolute maximum ratings” may cause permanent damage to the device. These are stress ratings only, and functional operation of the device at these or any other conditions beyond those indicated under “recommended operating conditions” is not implied. Exposure to absolute-maximum-rated conditions for extended periods may affect device reliability.

- NOTES: 1. All voltage values, except differential voltages, are with respect to network ground.  
2. Differential voltages are at IN+ with respect to IN–.

### DISSIPATION RATING TABLE

PACKAGE	T <sub>A</sub> ≤ 25°C POWER RATING	DERATING FACTOR ABOVE T <sub>A</sub> = 25°C	T <sub>A</sub> = 70°C POWER RATING	T <sub>A</sub> = 85°C POWER RATING	T <sub>A</sub> = 125°C POWER RATING
D	725 mW	5.8 mW/°C	464 mW	377 mW	145 mW
FK	1375 mW	11.0 mW/°C	880 mW	715 mW	275 mW
JG	1050 mW	8.4 mW/°C	672 mW	546 mW	210 mW
P	1000 mW	8.0 mW/°C	640 mW	520 mW	—
PW	525 mW	4.2 mW/°C	336 mW	273 mW	—



# TLC193, TLC393

## DUAL MICROPPOWER LinCMOS™ VOLTAGE COMPARATOR

SLCS115E – DECEMBER 1986 – REVISED JULY 2003

### recommended operating conditions

	TLC393C			UNIT
	MIN	NOM	MAX	
Supply voltage, $V_{DD}$	3	5	16	V
Common-mode input voltage, $V_{IC}$	-0.2		$V_{DD} - 1.5$	V
Low-level output current, $I_{OL}$			20	mA
Operating free-air temperature, $T_A$	0		70	°C

### electrical characteristics at specified operating free-air temperature, $V_{DD} = 5$ V (unless otherwise noted)

PARAMETER	TEST CONDITIONS†	$T_A$	TLC393C			UNIT
			MIN	TYP	MAX	
$V_{IO}$ Input offset voltage	$V_{IC} = V_{ICRmin}$ , $V_{DD} = 5$ V to 10 V, See Note 3	25°C		1.4	5	mV
		0°C to 70°C			6.5	
$I_{IO}$ Input offset current	$V_{IC} = 2.5$ V	25°C		1		pA
		70°C			0.3	nA
$I_{IB}$ Input bias current	$V_{IC} = 2.5$ V	25°C		5		pA
		70°C			0.6	nA
$V_{ICR}$ Common-mode input voltage range		25°C	0 to $V_{DD} - 1$			V
		0°C to 70°C	0 to $V_{DD} - 1.5$			
CMMR Common-mode rejection ratio	$V_{IC} = V_{ICRmin}$	25°C	84			dB
		70°C	84			
		0°C	84			
$k_{SVR}$ Supply-voltage rejection ratio	$V_{DD} = 5$ V to 10 V	25°C	85			dB
		70°C	85			
		0°C	85			
$V_{OL}$ Low-level output voltage	$V_{ID} = -1$ V, $I_{OL} = 6$ mA	25°C		300	400	mV
		70°C			650	
$I_{OH}$ High-level output current	$V_{ID} = 1$ V, $V_O = 5$ V	25°C		0.8	40	nA
		70°C			1	μA
$I_{DD}$ Supply current (both comparators)	Outputs low, No load	25°C		22	40	μA
		0°C to 70°C			50	

† All characteristics are measured with zero common-mode voltage unless otherwise noted.

NOTE 3: The offset voltage limits given are the maximum values required to drive the output up to 4.5 V or down to 0.3 V.



# TLC193, TLC393

## DUAL MICROWPOWER LinCMOS™ VOLTAGE COMPARATOR

SLCS115D – DECEMBER 1986 – REVISED JULY 2003

### recommended operating conditions

	TLC393I			UNIT
	MIN	NOM	MAX	
Supply voltage, $V_{DD}$	3	5	16	V
Common-mode input voltage, $V_{IC}$	-0.2		$V_{DD} - 1.5$	V
Low-level output current, $I_{OL}$			20	mA
Operating free-air temperature, $T_A$	-40		85	°C

### electrical characteristics at specified operating free-air temperature, $V_{DD} = 5$ V (unless otherwise noted)

PARAMETER	TEST CONDITION†	$T_A$	TLC393I			UNIT
			MIN	TYP	MAX	
$V_{IO}$ Input offset voltage	$V_{IC} = V_{ICRmin}$ , $V_{DD} = 5$ V to 10 V, See Note 3	25°C		1.4	5	mV
		-40°C to 85°C			7	
$I_{IO}$ Input offset current	$V_{IC} = 2.5$ V	25°C		1		pA
		85°C			1	nA
$I_{IB}$ Input bias current	$V_{IC} = 2.5$ V	25°C		5		pA
		85°C			2	nA
$V_{ICR}$ Common-mode input voltage range		25°C	0 to $V_{DD} - 1$			V
		-40°C to 85°C	0 to $V_{DD} - 1.5$			
CMMR Common-mode rejection ratio	$V_{IC} = V_{ICRmin}$	25°C	84			dB
		85°C	84			
		-40°C	84			
$k_{SVR}$ Supply-voltage rejection ratio	$V_{DD} = 5$ V to 10 V	25°C	85			dB
		85°C	85			
		-40°C	84			
$V_{OL}$ Low-level output voltage	$V_{ID} = -1$ V, $I_{OL} = 6$ mA	25°C	300	400		mV
		85°C	700			
$I_{OH}$ High-level output current	$V_{ID} = 1$ V, $V_O = 5$ V	25°C	0.8		40	nA
		85°C	1			μA
$I_{DD}$ Supply current (both comparators)	Outputs low, No load	25°C	22		40	μA
		-40°C to 85°C	65			

† All characteristics are measured with zero common-mode voltage unless otherwise noted.

NOTE 3: The offset voltage limits given are the maximum values required to drive the output up to 4.5 V or down to 0.3 V.



# TLC193, TLC393

## DUAL MICROPPOWER LinCMOS™ VOLTAGE COMPARATOR

SLCS115E – DECEMBER 1986 – REVISED JULY 2003

### recommended operating conditions

	TLC393Q			UNIT
	MIN	NOM	MAX	
Supply voltage, $V_{DD}$	4	5	16	V
Common-mode input voltage, $V_{IC}$	0	$V_{DD} - 1.5$		V
Low-level output current, $I_{OL}$	20			mA
Operating free-air temperature, $T_A$	-40	125		°C

### electrical characteristics at specified operating free-air temperature, $V_{DD} = 5$ V (unless otherwise noted)

PARAMETER	TEST CONDITION†	$T_A$	TLC393Q			UNIT
			MIN	TYP	MAX	
$V_{IO}$ Input offset voltage	$V_{IC} = V_{ICRmin}$ , $V_{DD} = 5$ V to 10 V, See Note 4	25°C	1.4		5	mV
		-40°C to 125°C	10			
$I_{IO}$ Input offset current	$V_{IC} = 2.5$ V	25°C	1			pA
		125°C			15	nA
$I_{IB}$ Input bias current	$V_{IC} = 2.5$ V	25°C	5			pA
		125°C			30	nA
$V_{ICR}$ Common-mode input voltage range		25°C	0 to $V_{DD} - 1$			V
		-40°C to 125°C	0 to $V_{DD} - 1.5$			
CMMR Common-mode rejection ratio	$V_{IC} = V_{ICRmin}$	25°C	84			dB
		125°C	84			
		-40°C	84			
$k_{SVR}$ Supply-voltage rejection ratio	$V_{DD} = 5$ V to 10 V	25°C	85			dB
		125°C	84			
		-40°C	84			
$V_{OL}$ Low-level output voltage	$V_{ID} = -1$ V, $I_{OL} = 6$ mA	25°C	300	400		mV
		125°C	800			
$I_{OH}$ High-level output current	$V_{ID} = 1$ V, $V_O = 5$ V	25°C	0.8	40		nA
		125°C	1			μA
$I_{DD}$ Supply current (both comparators)	Outputs low, No load	25°C	22	40		μA
		-40°C to 125°C	90			

† All characteristics are measured with zero common-mode voltage unless otherwise noted.

NOTE 4: The offset voltage limits given are the maximum values required to drive the output up to 4.5 V or down to 0.3 V (with a 2.5-kΩ load to  $V_{DD}$ ).



# TLC193, TLC393

## DUAL MICROWPOWER LinCMOS™ VOLTAGE COMPARATOR

SLCS115D – DECEMBER 1986 – REVISED JULY 2003

### recommended operating conditions

	TLC193M, TLC393M			UNIT
	MIN	NOM	MAX	
Supply voltage, $V_{DD}$	4	5	16	V
Common-mode input voltage, $V_{IC}$	0		$V_{DD} - 1.5$	V
Low-level output current, $I_{OL}$			20	mA
Operating free-air temperature, $T_A$	-55		125	°C

### electrical characteristics at specified operating free-air temperature, $V_{DD} = 5$ V (unless otherwise noted)

PARAMETER	TEST CONDITIONS†	$T_A$	TLC193M, TLC393M			UNIT
			MIN	TYP	MAX	
$V_{IO}$ Input offset voltage	$V_{IC} = V_{ICRmin}$ , $V_{DD} = 5$ V to 10 V, See Note 4	25°C		1.4	5	mV
		-55°C to 125°C			10	
$I_{IO}$ Input offset current	$V_{IC} = 2.5$ V	25°C		1		pA
		125°C			15	nA
$I_{IB}$ Input bias current	$V_{IC} = 2.5$ V	25°C		5		pA
		125°C			30	nA
$V_{ICR}$ Common-mode input voltage range		25°C	0 to $V_{DD} - 1$			V
		-55°C to 125°C	0 to $V_{DD} - 1.5$			
CMMR Common-mode rejection ratio	$V_{IC} = V_{ICRmin}$	25°C	84			dB
		125°C	84			
		-55°C	84			
kSVR Supply-voltage rejection ratio	$V_{DD} = 5$ V to 10 V	25°C	85			dB
		125°C	84			
		-55°C	84			
$V_{OL}$ Low-level output voltage	$V_{ID} = -1$ V, $I_{OL} = 6$ mA	25°C	300	400		mV
		125°C	800			
$I_{OH}$ High-level output current	$V_{ID} = 1$ V, $V_O = 5$ V	25°C	0.8		40	nA
		125°C	1			μA
$I_{DD}$ Supply current (both comparators)	Outputs low, No load	25°C	22		40	μA
		-55°C to 125°C	90			

† All characteristics are measured with zero common-mode voltage unless otherwise noted.

NOTE 4: The offset voltage limits given are the maximum values required to drive the output up to 4.5 V or down to 0.3 V (with a 2.5-kΩ load to  $V_{DD}$ ).



# TLC193, TLC393 DUAL MICROPOWER LinCMOS™ VOLTAGE COMPARATOR

SLCS115E – DECEMBER 1986 – REVISED JULY 2003

switching characteristics,  $V_{DD} = 5\text{ V}$ ,  $T_A = 25^\circ\text{C}$  (see Figure 3)

PARAMETER	TEST CONDITIONS	TLC393C, TLC393I TLC393Q, TLC193M, TLC393M			UNIT
		MIN	TYP	MAX	
$t_{PLH}$ Propagation delay time, low-to-high-level output	$f = 10\text{ kHz}$ , $C_L = 15\text{ pF}$	Overdrive = 2 mV	4.5		$\mu\text{s}$
		Overdrive = 5 mV	2.5		
		Overdrive = 10 mV	1.7		
		Overdrive = 20 mV	1.2		
		Overdrive = 40 mV	1.1		
$t_{PHL}$ Propagation delay time, high-to-low-level output	$f = 10\text{ kHz}$ , $C_L = 15\text{ pF}$	$V_I = 1.4\text{-V}$ step at IN+	1.1		$\mu\text{s}$
		Overdrive = 2 mV	3.6		
		Overdrive = 5 mV	2.1		
		Overdrive = 10 mV	1.3		
		Overdrive = 20 mV	0.85		
		Overdrive = 40 mV	0.55		
$t_f$ Fall time, output	$f = 10\text{ kHz}$ , $C_L = 15\text{ pF}$	$V_I = 1.4\text{-V}$ step at IN+	0.10		ns
		Overdrive = 50 mV	22		

## PARAMETER MEASUREMENT INFORMATION

The TLC393 contains a digital output stage which, if held in the linear region of the transfer curve, can cause damage to the device. Conventional operational amplifier/comparator testing incorporates the use of a servo loop that is designed to force the device output to a level within this linear region. Since the servo-loop method of testing cannot be used, the following alternatives for testing parameters such as input offset voltage, common-mode rejection ratio, etc., are suggested.

To verify that the input offset voltage falls within the limits specified, the limit value is applied to the input as shown in Figure 1(a). With the noninverting input positive with respect to the inverting input, the output should be high. With the input polarity reversed, the output should be low.

A similar test can be made to verify the input offset voltage at the common-mode extremes. The supply voltages can be slewed as shown in Figure 1(b) for the  $V_{ICR}$  test, rather than changing the input voltages, to provide greater accuracy.

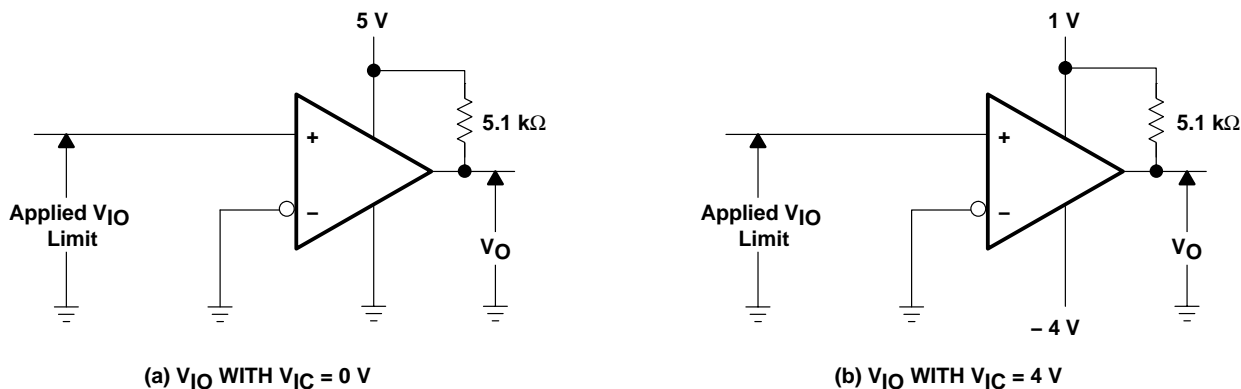

**Figure 1. Method for Verifying That Input Offset Voltage Is Within Specified Limits**



**PACKAGING INFORMATION**

Orderable Device	Status <sup>(1)</sup>	Package Type	Package Drawing	Pins	Package Qty	Eco Plan <sup>(2)</sup>	Lead/Ball Finish	MSL Peak Temp <sup>(3)</sup>
5962-9555101NXDR	ACTIVE	SOIC	D	8	2500	TBD	CU NIPDAU	Level-1-220C-UNLIM
5962-9555101QPA	ACTIVE	CDIP	JG	8	1	TBD	A42 SNPB	Level-NC-NC-NC
TLC193MFKB	OBSOLETE	LCCC	FK	20		TBD	Call TI	Call TI
TLC193MJG	OBSOLETE	CDIP	JG	8		TBD	Call TI	Call TI
TLC193MJGB	ACTIVE	CDIP	JG	8	1	TBD	A42 SNPB	Level-NC-NC-NC
TLC393CD	ACTIVE	SOIC	D	8	75	Green (RoHS & no Sb/Br)	CU NIPDAU	Level-1-260C-UNLIM
TLC393CDR	ACTIVE	SOIC	D	8	2500	Green (RoHS & no Sb/Br)	CU NIPDAU	Level-1-260C-UNLIM
TLC393CP	ACTIVE	PDIP	P	8	50	Pb-Free (RoHS)	CU NIPDAU	Level-NC-NC-NC
TLC393CPE4	ACTIVE	PDIP	P	8	50	Pb-Free (RoHS)	CU NIPDAU	Level-NC-NC-NC
TLC393CPSR	ACTIVE	SO	PS	8	2000	Pb-Free (RoHS)	CU NIPDAU	Level-2-260C-1YEAR/ Level-1-220C-UNLIM
TLC393CPW	ACTIVE	TSSOP	PW	8	150	TBD	CU NIPDAU	Level-1-220C-UNLIM
TLC393CPWLE	OBSOLETE	TSSOP	PW	8		TBD	Call TI	Call TI
TLC393CPWR	ACTIVE	TSSOP	PW	8	2000	TBD	CU NIPDAU	Level-1-220C-UNLIM
TLC393CPWRG4	ACTIVE	TSSOP	PW	8	2000	Green (RoHS & no Sb/Br)	CU NIPDAU	Level-1-260C-UNLIM
TLC393ID	ACTIVE	SOIC	D	8	75	Green (RoHS & no Sb/Br)	CU NIPDAU	Level-1-260C-UNLIM
TLC393IDR	ACTIVE	SOIC	D	8	2500	Green (RoHS & no Sb/Br)	CU NIPDAU	Level-1-260C-UNLIM
TLC393IP	ACTIVE	PDIP	P	8	50	Pb-Free (RoHS)	CU NIPDAU	Level-NC-NC-NC
TLC393IPE4	ACTIVE	PDIP	P	8	50	Pb-Free (RoHS)	CU NIPDAU	Level-NC-NC-NC
TLC393IPW	ACTIVE	TSSOP	PW	8	150	TBD	CU NIPDAU	Level-1-220C-UNLIM
TLC393IPWLE	OBSOLETE	TSSOP	PW	8		TBD	Call TI	Call TI
TLC393IPWR	ACTIVE	TSSOP	PW	8	2000	TBD	CU NIPDAU	Level-1-220C-UNLIM
TLC393MD	OBSOLETE	SOIC	D	8		TBD	Call TI	Call TI
TLC393MP	OBSOLETE	PDIP	P	8		TBD	Call TI	Call TI
TLC393QDR	ACTIVE	SOIC	D	8	2500	TBD	CU NIPDAU	Level-1-220C-UNLIM

<sup>(1)</sup> The marketing status values are defined as follows:

**ACTIVE:** Product device recommended for new designs.

**LIFEBUY:** TI has announced that the device will be discontinued, and a lifetime-buy period is in effect.

**NRND:** Not recommended for new designs. Device is in production to support existing customers, but TI does not recommend using this part in a new design.

**PREVIEW:** Device has been announced but is not in production. Samples may or may not be available.

**OBSOLETE:** TI has discontinued the production of the device.

<sup>(2)</sup> Eco Plan - The planned eco-friendly classification: Pb-Free (RoHS) or Green (RoHS & no Sb/Br) - please check <http://www.ti.com/productcontent> for the latest availability information and additional product content details.

**TBD:** The Pb-Free/Green conversion plan has not been defined.

**Pb-Free (RoHS):** TI's terms "Lead-Free" or "Pb-Free" mean semiconductor products that are compatible with the current RoHS requirements for all 6 substances, including the requirement that lead not exceed 0.1% by weight in homogeneous materials. Where designed to be soldered at high temperatures, TI Pb-Free products are suitable for use in specified lead-free processes.

PW (R-PDSO-G\*\*)

PLASTIC SMALL-OUTLINE PACKAGE

14 PINS SHOWN



4040064/F 01/97

- NOTES: A. All linear dimensions are in millimeters.  
 B. This drawing is subject to change without notice.  
 C. Body dimensions do not include mold flash or protrusion not to exceed 0,15.  
 D. Falls within JEDEC MO-153

## IMPORTANT NOTICE

Texas Instruments Incorporated and its subsidiaries (TI) reserve the right to make corrections, modifications, enhancements, improvements, and other changes to its products and services at any time and to discontinue any product or service without notice. Customers should obtain the latest relevant information before placing orders and should verify that such information is current and complete. All products are sold subject to TI's terms and conditions of sale supplied at the time of order acknowledgment.

TI warrants performance of its hardware products to the specifications applicable at the time of sale in accordance with TI's standard warranty. Testing and other quality control techniques are used to the extent TI deems necessary to support this warranty. Except where mandated by government requirements, testing of all parameters of each product is not necessarily performed.

TI assumes no liability for applications assistance or customer product design. Customers are responsible for their products and applications using TI components. To minimize the risks associated with customer products and applications, customers should provide adequate design and operating safeguards.

TI does not warrant or represent that any license, either express or implied, is granted under any TI patent right, copyright, mask work right, or other TI intellectual property right relating to any combination, machine, or process in which TI products or services are used. Information published by TI regarding third-party products or services does not constitute a license from TI to use such products or services or a warranty or endorsement thereof. Use of such information may require a license from a third party under the patents or other intellectual property of the third party, or a license from TI under the patents or other intellectual property of TI.

Reproduction of information in TI data books or data sheets is permissible only if reproduction is without alteration and is accompanied by all associated warranties, conditions, limitations, and notices. Reproduction of this information with alteration is an unfair and deceptive business practice. TI is not responsible or liable for such altered documentation.

Resale of TI products or services with statements different from or beyond the parameters stated by TI for that product or service voids all express and any implied warranties for the associated TI product or service and is an unfair and deceptive business practice. TI is not responsible or liable for any such statements.

Following are URLs where you can obtain information on other Texas Instruments products and application solutions:

<b>Products</b>		<b>Applications</b>	
Amplifiers	<a href="http://amplifier.ti.com">amplifier.ti.com</a>	Audio	<a href="http://www.ti.com/audio">www.ti.com/audio</a>
Data Converters	<a href="http://dataconverter.ti.com">dataconverter.ti.com</a>	Automotive	<a href="http://www.ti.com/automotive">www.ti.com/automotive</a>
DSP	<a href="http://dsp.ti.com">dsp.ti.com</a>	Broadband	<a href="http://www.ti.com/broadband">www.ti.com/broadband</a>
Interface	<a href="http://interface.ti.com">interface.ti.com</a>	Digital Control	<a href="http://www.ti.com/digitalcontrol">www.ti.com/digitalcontrol</a>
Logic	<a href="http://logic.ti.com">logic.ti.com</a>	Military	<a href="http://www.ti.com/military">www.ti.com/military</a>
Power Mgmt	<a href="http://power.ti.com">power.ti.com</a>	Optical Networking	<a href="http://www.ti.com/opticalnetwork">www.ti.com/opticalnetwork</a>
Microcontrollers	<a href="http://microcontroller.ti.com">microcontroller.ti.com</a>	Security	<a href="http://www.ti.com/security">www.ti.com/security</a>
		Telephony	<a href="http://www.ti.com/telephony">www.ti.com/telephony</a>
		Video & Imaging	<a href="http://www.ti.com/video">www.ti.com/video</a>
		Wireless	<a href="http://www.ti.com/wireless">www.ti.com/wireless</a>

Mailing Address: Texas Instruments  
Post Office Box 655303 Dallas, Texas 75265