

# TMS28F004Axy, TMS28F400Axy 524288 BY 8-BIT/262144 BY 16-BIT AUTO-SELECT BOOT-BLOCK FLASH MEMORIES

SMJS829A – JANUARY 1996 – REVISED AUGUST 1997

- Organization . . . 524288 By 8 Bits  
262144 By 16 Bits
- Array-Blocking Architecture
  - One 16K-Byte Protected Boot Block
  - Two 8K-Byte Parameter Blocks
  - One 96K-Byte Main Block
  - Three 128K-Byte Main Blocks
  - Top or Bottom Boot Locations
- '28F400Axy Offers a User-Defined 8-Bit (Byte) or 16-Bit (Word) Organization
- '28F004Axy Offers Only the 8-Bit Organization
- Maximum Access/Minimum Cycle Time
  - Commercial and Extended
 

5-V $V_{CC} \pm 10\%$	3.3-V $V_{CC} \pm 0.3 V$
'28F400Axy60 60 ns 110 ns	
'28F400Axy70 70 ns 130 ns	
'28F400Axy80 80 ns 150 ns	
  - Automotive (offered for only 5-V  $V_{CC}$  voltage configurations)
 

5-V $V_{CC} \pm 10\%$
'28F400Axy70 70 ns
'28F400Axy80 80 ns
'28F400Axy90 90 ns
- (x = S, E, F, M, or Z Depending on  $V_{CC}/V_{PP}$  Configuration)
- (y = T or B for Top or Bottom Boot-Block Configuration)
- 100000 and 10000 Program/Erase Cycle Versions
- Three Temperature Ranges
  - Commercial . . . 0°C to 70°C
  - Extended . . . – 40°C to 85°C
  - Automotive . . . – 40°C to 125°C
- Industry Standard Packages Offered in
  - 40-Pin TSOP (DCD Suffix)
  - 44-Pin PSOP (DBJ Suffix)
  - 48-Pin TSOP (DCD Suffix)
- Low Power Dissipation ( $V_{CC} = 5.5 V$ )
  - Active Write . . . 248 mW (Byte Write)
  - Active Read . . . 330 mW (Byte Read)
  - Active Write . . . 248 mW (Word Write)
  - Active Read . . . 330 mW (Word Read)
  - Block Erase . . . 165 mW
  - Standby . . . 0.72 mW (CMOS-Input Levels)

## DBJ PACKAGE (TOP VIEW)

$V_{PP}$	1	44	$\overline{RP}$
DU/WP	2	43	$\overline{W}$
A17	3	42	A8
A7	4	41	A9
A6	5	40	A10
A5	6	39	A11
A4	7	38	A12
A3	8	37	A13
A2	9	36	A14
A1	10	35	A15
A0	11	34	A16
$\overline{E}$	12	33	$\overline{BYTE}$
$V_{SS}$	13	32	$V_{SS}$
$\overline{G}$	14	31	DQ15/A <sub>-1</sub>
DQ0	15	30	DQ7
DQ8	16	29	DQ14
DQ1	17	28	DQ6
DQ9	18	27	DQ13
DQ2	19	26	DQ5
DQ10	20	25	DQ12
DQ3	21	24	DQ4
DQ11	22	23	$V_{CC}$

## PIN NOMENCLATURE

A0–A17	Address Inputs
$\overline{BYTE}$	Byte Enable
DQ0–DQ14	Data In/Out
DQ15/A <sub>-1</sub>	Data In/Out (word-wide mode), Low-Order Address (byte-wide mode)
$\overline{E}$	Chip Enable
$\overline{G}$	Output Enable
NC	No Internal Connection
$\overline{RP}$	Reset/Deep Power-Down
$V_{CC}$	Power Supply
$V_{PP}$	Power Supply for Program/Erase
$V_{SS}$	Ground
$\overline{W}$	Write Enable
DU/WP	Do Not Use for 'AMy or 'AZy /Write Protect

- Fully Automated On-Chip Erase and Word/Byte Program Operations
- Write Protection for Boot Block
- Industry Standard Command-State Machine (CSM)
  - Erase Suspend/Resume
  - Algorithm-Selection Identifier
- Three Different Combinations of Supply Voltages Offered
- All Inputs/Outputs TTL Compatible



Please be aware that an important notice concerning availability, standard warranty, and use in critical applications of Texas Instruments semiconductor products and disclaimers thereto appears at the end of this data sheet.

PRODUCTION DATA information is current as of publication date. Products conform to specifications per the terms of Texas Instruments standard warranty. Production processing does not necessarily include testing of all parameters.



Copyright © 1997, Texas Instruments Incorporated

**TMS28F004Axy, TMS28F400Axy**  
**524288 BY 8-BIT/262144 BY 16-BIT**  
**AUTO-SELECT BOOT-BLOCK FLASH MEMORIES**

SMJS829A – JANUARY 1996 – REVISED AUGUST 1997

**DCD PACKAGE-40 PIN**  
**(TOP VIEW)**



**DCD PACKAGE-48 PIN**  
**(TOP VIEW)**

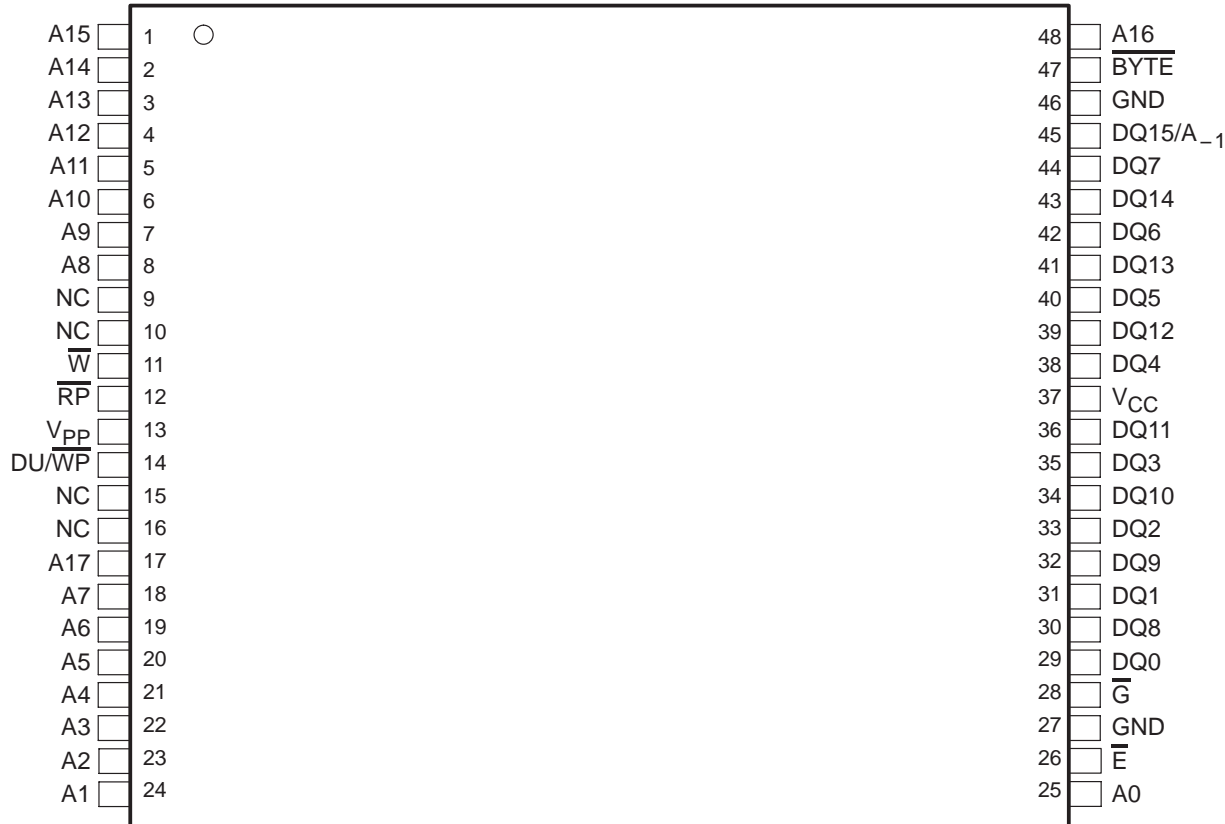

# TMS28F004Axy, TMS28F400Axy 524288 BY 8-BIT/262144 BY 16-BIT AUTO-SELECT BOOT-BLOCK FLASH MEMORIES

SMJS829A – JANUARY 1996 – REVISED AUGUST 1997

Table of Contents	
description .....	3
device symbol nomenclature .....	5
functional block diagram .....	6
architecture .....	6
block memory maps .....	6
boot-block data protection .....	8
parameter block .....	8
main block .....	8
data protection .....	8
command-state machine (CSM) .....	8
operation .....	9
command definitions .....	9
status register .....	10
byte-wide or word-wide mode selection .....	11
command-state machine (CSM) operations .....	13
clear status register .....	13
read operations .....	14
programming operations .....	14
erase operations .....	15
automatic power-saving mode .....	15
reset/deep power-down mode .....	15
power-supply detection .....	16
absolute maximum ratings .....	21
capacitance .....	22
TMS28F004ASy and TMS28F400ASy .....	23
TMS28F004AEy and TMS28F400AEy .....	33
TMS28F004AMy and TMS28F400AMy .....	44
TMS28F004AFy and TMS28F400AFy .....	52
TMS28F004AZy and TMS28F400AZy .....	62
Parameter Measurement Information .....	71
mechanical data – DBJ (R-PDSO-G44) .....	78
mechanical data – DCD (R-PDSO-G**) .....	79

## description

The TMS28F400Axy is a 524288 by 8 bits/262144 by 16 bits (4194304-bit), boot-block flash memory that can be electrically block-erased and reprogrammed. The TMS28F400Axy is organized in a blocked architecture consisting of:

- One 16K-byte protected boot block
- Two 8K-byte parameter blocks
- One 96K-byte main block
- Three 128K-byte main blocks

Table 1 lists the five different voltage configurations available for ordering. Operation as a 512K-byte (8-bit) or a 256K-word (16-bit) organization is user-definable.

**Table 1. V<sub>CC</sub>/V<sub>PP</sub> Voltage Configurations, Temperature, and Speeds Matrix**

DEVICE	DEVICE CONFIGURATION		TEMPERATURE (T <sub>A</sub> )	ACCESS SPEEDS – 5-V(3.3-V) V <sub>CC</sub>
	READ (V <sub>CC</sub> )	PROGRAM/ERASE (V <sub>PP</sub> )		
TMS28F400ASy	3.3 V ± 0.3 V or 5 V ± 10%	5 V ± 10% or 12 V ± 5%	0°C to 70°C	60(110), 70(130), 80(150) ns
			–40°C to 85°C	60(110), 70(130), 80(150) ns
TMS28F400AEy	2.7 to 3.6 V or 5 V ± 10%	5 V ± 10% or 12 V ± 5%	0°C to 70°C	60(110), 70(130), 80(150) ns
			–40°C to 85°C	60(110), 70(130), 80(150) ns
TMS28F400AMy	3.3 V ± 0.3 V or 5 V ± 10%	12 V ± 10%	0°C to 70°C	60(110), 70(130), 80(150) ns
			–40°C to 85°C	60(110), 70(130), 80(150) ns
TMS28F400AFy	5 V ± 10%	5 V ± 10% or 12 V ± 5%	0°C to 70°C	60, 70, 80 ns
			–40°C to 85°C	60, 70, 80 ns
			–40°C to 125°C†	70, 80, 90 ns
TMS28F400AZy	5 V ± 10%	12 V ± 10%	0°C to 70°C	60, 70, 80 ns
			–40°C to 85°C	60, 70, 80 ns
			–40°C to 125°C†	70, 80, 90 ns

† Only the 44-pin PSOP is offered in the –40°C to 125°C temperature range.

NOTE 1: All configurations are available in the TMS28F004Axy (8 bit configuration only) and top or bottom boot.



# TMS28F004Axy, TMS28F400Axy 524288 BY 8-BIT/262144 BY 16-BIT AUTO-SELECT BOOT-BLOCK FLASH MEMORIES

SMJS829A – JANUARY 1996 – REVISED AUGUST 1997

---

## description (continued)

The TMS28F004Axy is offered in a 512K-byte organization only. The operation for this device is the same as the TMS28F400Axy and is offered in the same voltage configurations. TMS28F004Axy can be substituted for the byte-wide TMS28F400Axy with the latter being the generic name for this device family.

Embedded program and block-erase functions are fully automated by the on-chip write state machine (WSM), simplifying these operations and relieving the system microcontroller of secondary tasks. WSM status can be monitored by an on-chip status register to determine progress of program/erase tasks. The device features user-selectable block erasure.

The configurations are as follows:

- The TMS28F400ASy configuration has the auto-select feature that allows the user alternative read and program/erase voltages. Memory reads can be performed using 3.3-V  $V_{CC}$  for optimum power consumption or 5-V  $V_{CC}$  for device performance. Erasing or programming the device can be accomplished with 5-V  $V_{PP}$ , which eliminates having to use a 12-V source and/or in-system voltage converters. Alternatively, 12-V  $V_{PP}$  operation exists for systems that already have a 12-V power supply, which provides faster programming and erasing times. This configuration is offered in two temperature ranges: 0°C to 70°C and –40°C to 85°C.
- The TMS28F400AEy configuration offers the auto-select feature of the TMS28F400ASy with an extended  $V_{CC}$  range of 2.7-V to 3.6-V (3-V nominal). Memory reads can be performed using 3-V  $V_{CC}$ , for more efficient power consumption than the 'ASy device.
- The TMS28F400AMy configuration offers a 3-V or 5-V memory read with a 12-V program and erase. This configuration is intended for low 3.3-V reads and the fast programming offered with the 12-V  $V_{PP}$  and 5-V  $V_{CC}$ . This configuration is offered in two temperature ranges: 0°C to 70°C and –40°C to 85°C.
- The TMS28F400AFy configuration offers a 5-V memory read with a 5-V or 12-V program and erase. This configuration is intended for systems using a single 5-V power supply. This configuration is offered in three temperature ranges: 0°C to 70°C, –40°C to 85°C, and –40°C to 125°C.
- The TMS28F400AZy configuration offers a 5-V memory read with a 12-V program and erase for fast programming and erasing times. This configuration is offered in three temperature ranges: 0°C to 70°C, –40°C to 85°C, and –40°C to 125°C.

The y in the device name represents a T for top or B for bottom boot-block configuration.

All configurations of the TMS28F400Axy are offered in a 44-pin plastic small-outline package (PSOP) and a 48-pin thin small-outline package (TSOP). The TMS28F004Axy is offered in a 40-pin TSOP only. Both the 40-pin and 48-pin TSOP are offered for the 0°C to 70°C and –40°C to 85°C temperature ranges only.



**TMS28F004Axy, TMS28F400Axy**  
**524288 BY 8-BIT/262144 BY 16-BIT**  
**AUTO-SELECT BOOT-BLOCK FLASH MEMORIES**

SMJS829A – JANUARY 1996 – REVISED AUGUST 1997

**device symbol nomenclature**

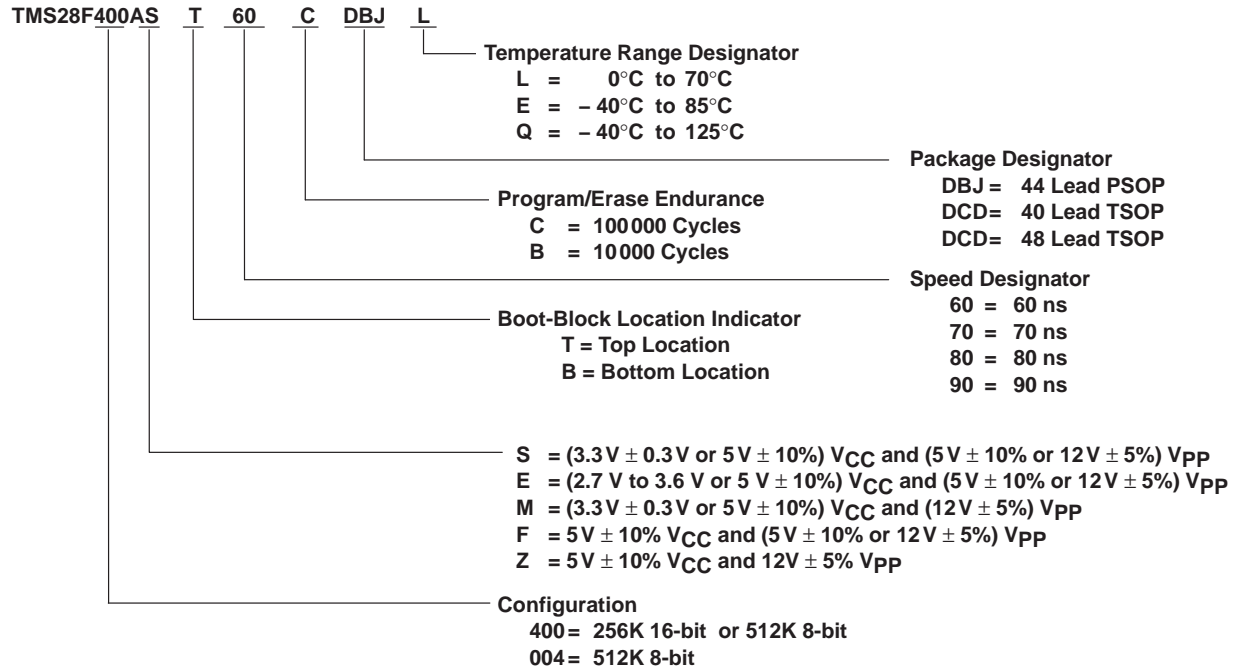

# TMS28F004Axy, TMS28F400Axy 524288 BY 8-BIT/262144 BY 16-BIT AUTO-SELECT BOOT-BLOCK FLASH MEMORIES

SMJS829A – JANUARY 1996 – REVISED AUGUST 1997

## functional block diagram

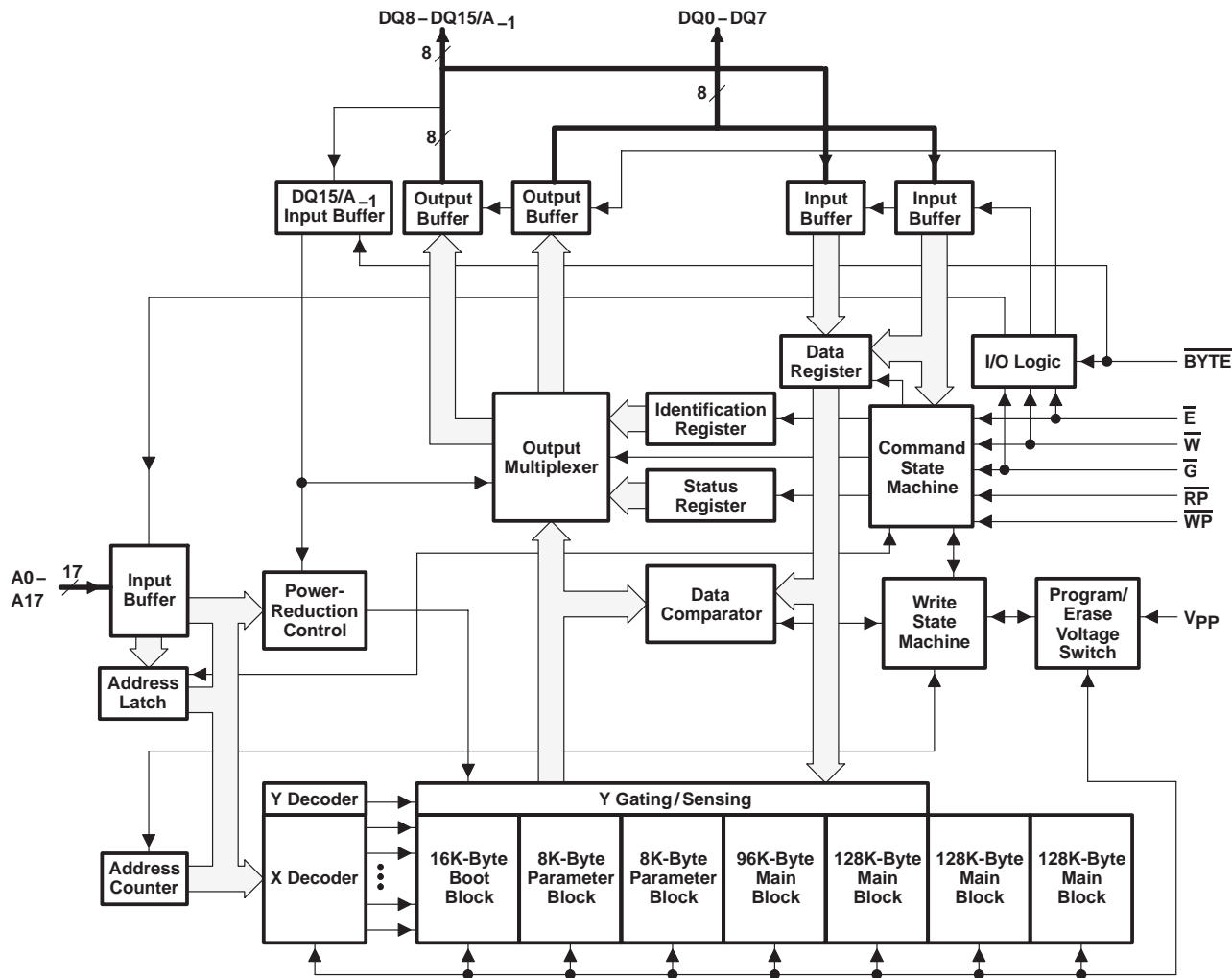

## architecture

The TMS28F400Axy uses a blocked architecture to allow independent erasure of selected memory blocks. The block to be erased is selected by using any valid address within that block.

## block memory maps

The TMS28F400Axy is available with the block architecture mapped in either of two configurations: the boot block located at the top or at the bottom of the memory array, as required by different microprocessors. The TMS28F400AxB (bottom boot block) is mapped with the 16K-byte boot block located at the low-order address range (00000h to 01FFFh). The TMS28F400AxT (top boot block) is inverted with respect to the TMS28F400AxB with the boot block located at the high-order address range (3E000h to 3FFFFh). Both of these address ranges are for word-wide mode. Figure 1 and Figure 2 show the memory maps for these configurations. The TMS28F004Axy is mapped as the 8-bit configuration of the TMS28F400Axy, except that the least significant bit (LSB) is A0 instead of A\_{-1}.



**TMS28F004Axy, TMS28F400Axy**  
**524288 BY 8-BIT/262144 BY 16-BIT**  
**AUTO-SELECT BOOT-BLOCK FLASH MEMORIES**

SMJS829A – JANUARY 1996 – REVISED AUGUST 1997

**block memory maps (continued)**

Address Range	8-Bit Configuration	16-Bit Configuration	Address Range
7FFFh	Boot Block 16K Addresses	Boot Block 8K Addresses	3FFFh
7C00h	Parameter Block 8K Addresses	Parameter Block 4K Addresses	3E00h
7BFFh			3DFFFh
7A00h	Parameter Block 8K Addresses	Parameter Block 4K Addresses	3D00h
79FFh			3CFFFh
7800h	Main Block 96K Addresses	Main Block 48K Addresses	3C00h
77FFh			3BFFFh
6000h	Main Block 128K Addresses	Main Block 64K Addresses	3000h
5FFFh			2FFFFh
4000h	Main Block 128K Addresses	Main Block 64K Addresses	2000h
3FFFh			1FFFFh
2000h	Main Block 128K Addresses	Main Block 64K Addresses	1000h
1FFFh			0FFFFh
0000h			0000h

DQ15/A<sub>-1</sub> Is LSB Address

A0 Is LSB Address

NOTE A: The TMS28F004AxT is mapped the same as the 8-bit configuration of the TMS28F400AxT except that the LSB is A0.

**Figure 1. TMS28F400AxT (Top Boot Block) Memory Map (See Note A)**

Address Range	8-Bit Configuration	16-Bit Configuration	Address Range
7FFFh	Main Block 128K Addresses	Main Block 64K Addresses	3FFFh
6000h	Main Block 128K Addresses	Main Block 64K Addresses	3000h
5FFFh			2FFFFh
4000h	Main Block 128K Addresses	Main Block 64K Addresses	2000h
3FFFh			1FFFFh
2000h	Main Block 96K Addresses	Main Block 48K Addresses	1000h
1FFFh			0FFFFh
0800h	Parameter Block 8K Addresses	Parameter Block 4K Addresses	0400h
07FFh			03FFFh
0600h	Parameter Block 8K Addresses	Parameter Block 4K Addresses	0300h
05FFh			02FFFh
0400h	Boot Block 16K Addresses	Boot Block 8K Addresses	0200h
03FFh			01FFFh
0000h			0000h

DQ15/A<sub>-1</sub> Is LSB Address

A0 Is LSB Address

NOTE A: The TMS28F004AxB is mapped the same as the 8-bit configuration of the TMS28F400AxB except that the LSB is A0.

**Figure 2. TMS28F400AxB (Bottom Boot Block) Memory Map (See Note A)**



# TMS28F004Axy, TMS28F400Axy

## 524288 BY 8-BIT/262144 BY 16-BIT

### AUTO-SELECT BOOT-BLOCK FLASH MEMORIES

SMJS829A – JANUARY 1996 – REVISED AUGUST 1997

#### boot-block data protection

The 16K-byte boot block can be used to store key system data that is seldom changed in normal operation. Data in this block can be secured by using different combinations of the reset/power-down pin ( $\overline{RP}$ ), the write protect pin ( $\overline{WP}$ ) and  $V_{PP}$  supply levels. Table 2 provides a list of these combinations.

#### parameter block

Two parameter blocks of 8K bytes each can be used like a scratch pad to store frequently updated data. Alternatively, the parameter blocks can be used for additional boot- or main-block data. If a parameter block is used to store additional boot-block data, caution must be exercised because the parameter block does not have the boot-block data-protection safety feature.

#### main block

Primary memory on the TMS28F400Axy is located in four main blocks. Three of the blocks have storage capacity for 128K bytes and the fourth block has storage capacity for 96K bytes.

#### data protection

Data is secured or unsecured by using different combinations of the reset/power-down pin ( $\overline{RP}$ ), the write protect pin ( $\overline{WP}$ ), and  $V_{PP}$  supply levels. Table 2 provides a list of these combinations.

There are two configurations to secure the entire memory against inadvertent alteration of data. The  $V_{PP}$  supply pin can be held below the  $V_{PP}$  lock-out voltage level ( $V_{PPPLK}$ ) or the reset/deep power-down pin ( $\overline{RP}$ ) can be pulled to a logic-low level. Note if  $\overline{RP}$  is held low, the device resets which means it powers down and, therefore, cannot be read. Typically this pin tied to the system reset for additional protection during system power up.

The boot block sector has an additional security feature through the  $\overline{WP}$  pin ('ASy, 'AEy, and 'AFy device configurations only). When the  $\overline{RP}$  pin is at a logic-high level, the  $\overline{WP}$  pin controls whether the boot block sector is protected. When  $\overline{WP}$  is held at the logic-low level, the boot block is protected. When  $\overline{WP}$  is held at the logic-high level, the boot block is unprotected along with the rest of the other sectors. Alternatively, the entire memory for all voltage configurations can be unprotected by pulling the  $\overline{RP}$  pin to  $V_{HH}$  (12 V).

**Table 2. Data-Protection Combinations**

DATA PROTECTION PROVIDED	'ASy, 'AEy, OR 'AFy			'AMy OR 'AZy		
	$V_{PP}$	$\overline{RP}$	$\overline{WPT}$	$V_{PP}$	$\overline{RP}$	$\overline{WPT}$
All blocks locked	$V_{IL}$	X	X	$V_{IL}$	X	X
All blocks locked (reset)	X	$V_{IL}$	X	X	$V_{IL}$	X
All blocks unlocked	$>V_{PPPLK}$	$V_{HH}$	X	$V_{HH}$	$V_{HH}$	X
	$>V_{PPPLK}$	$V_{IH}$	$V_{IH}$			
Only boot block locked	$>V_{PPPLK}$	$V_{IH}$	$V_{IL}$	$V_{HH}$	$V_{IH}$	X

† For the TMS28F400AZy and TMS28F400AMy 12-V  $V_{PP}$ -only products, the  $\overline{WP}$  pin is disabled and can be left floating. To unlock blocks,  $\overline{RP}$  must be at  $V_{HH}$ .

#### command-state machine (CSM)

Commands are issued to the CSM using standard microprocessor write timings. The CSM acts as an interface between the external microprocessor and the internal WSM. The available commands are listed in Table 3 and the descriptions of these commands are shown in Table 4. When a program or erase command is issued to the CSM, the WSM controls the internal sequences and the CSM responds only to status reads. After the WSM completes its task, the WSM status bit (SB7) is set to a logic-high level (1), allowing the CSM to respond to the full command set again.



## operation

Device operations are selected by entering standard JEDEC 8-bit command codes with conventional microprocessor timing into an on-chip CSM through I/O pins DQ0–DQ7. When the device is powered up, internal reset circuitry initializes the chip to a read-array mode of operation. Changing the mode of operation requires a command code to be entered into the CSM. Table 3 lists the CSM codes for all modes of operation.

The on-chip status register allows the progress of various operations to be monitored. The status register is interrogated by entering a read-status-register command into the CSM (cycle 1) and reading the register data on I/O pins DQ0–DQ7 (cycle 2). Status-register bits SB0 through SB7 correspond to DQ0 through DQ7.

**Table 3. CSM Codes for Device Mode Selection**

COMMAND CODE ON DQ0–DQ7†	DEVICE MODE
00h	Invalid/Reserved
10h	Alternate Program Setup
20h	Block-Erase Setup
40h	Program Setup
50h	Clear Status Register
70h	Read Status Register
90h	Algorithm Selection
B0h	Erase-Suspend
D0h	Erase-Resume/Block-Erase Confirm
FFh	Read Array

† DQ0 is the least significant bit. DQ8–DQ15 can be any valid 2-state level.

## command definitions

Once a specific command code has been entered, the WSM executes an internal algorithm generating the necessary timing signals to program, erase, and verify data. See Table 4 for the CSM command definitions and data for each of the bus cycles. Table 5 lists the status register bits and definitions.

Following the read-algorithm-selection-code command, two read cycles are required to access the manufacturer-equivalent code and the device-equivalent code. Table 6, Table 7, and Table 8 list the code.

**TMS28F004Axy, TMS28F400Axy**  
**524288 BY 8-BIT/262144 BY 16-BIT**  
**AUTO-SELECT BOOT-BLOCK FLASH MEMORIES**

SMJS829A – JANUARY 1996 – REVISED AUGUST 1997

**command definitions (continued)**

**Table 4. Command Definitions**

COMMAND	BUS CYCLES REQUIRED	FIRST BUS CYCLE			SECOND BUS CYCLE		
		OPERATION	ADDRESS	CSM INPUT	OPERATION	ADDRESS	DATA IN/OUT
<b>Read Operations</b>							
Read Array	1	Write	X	FFh	Read	X	Data Out
Read Algorithm-Selection Code	2	Write	X	90h	Read	A0	M/D
Read-Status Register	2	Write	X	70h	Read	X	SRB
Clear-Status Register	1	Write	X	50h			
<b>Program Mode</b>							
Program Setup/Program (byte/word)	2	Write	PA	40h or 10h	Write	PA	PD
<b>Erase Operations</b>							
Block-Erase Setup/Block-Erase Confirm	2	Write	BEA	20h	Write	BEA	D0h
Erase Suspend/Erase Resume	2	Write	X	B0h	Write	X	D0h

**Legend:**

- BEA Block-erase address. Any address selected within a block selects that block for erase.
- M/D Manufacturer-equivalent/ device-equivalent code
- PA Address to be programmed
- PD Data to be programmed at PA
- SRB Status-register data byte that can be found on DQ0–DQ7
- X Don't care

**status register**

The status register allows the user to determine whether the state of a program/erase operation is pending or complete. The status register is monitored by writing a read-status command to the CSM and reading the resulting status code on I/O pins DQ0–DQ7. This is valid for operation in either the byte- or word-wide mode. When writing to the CSM in word-wide mode, the high order I/O pins (DQ8–DQ15) can be set to any valid 2-state level. When reading the status bits during a word-wide read operation, the high order I/Os (DQ8–DQ15) are set to 00h internally, so the user needs to interpret only the low order I/O pins (D0–DQ7).

After a read-status command has been given, the data appearing on DQ0–DQ7 remains as status register data until a new command is issued to the CSM. To return the device to other modes of operation, a new command must be issued to the CSM.

Register data is updated on the falling edge of  $\bar{G}$  or  $\bar{E}$ . The latest falling edge of either of these two signals updates the latch within a given read cycle. Latching the data prevents errors from occurring if the register input change during a status-register read. To ensure that the status-register output contains updated status data,  $\bar{E}$  or  $\bar{G}$  must be toggled for each subsequent status read.

The status register provides the internal state of the WSM to the external microprocessor. During periods when the WSM is active, the status register can be polled to determine the WSM status. Table 5 defines the status register bits and their functions.



status register (continued)

**Table 5. Status-Register Bit Definitions and Functions**

STATUS BIT	FUNCTION	DATA	COMMENTS
SB7	Write-state-machine status	1 = Ready 0 = Busy	If SB7 = 0 (busy), the WSM has not completed an erase or programming operation. If SB7 = 1 (ready), other polling operations can be performed. Until this occurs, the other status bits are not valid. If the WSM status bit shows busy (0), the user must toggle $\bar{E}$ or $\bar{G}$ periodically to determine when the WSM has completed an operation (SB7 = 1) since SB7 is not updated automatically at the completion of a WSM task.
SB6	Erase-suspend status (ESS)	1 = Erase suspended 0 = Erase in progress or completed	When an erase-suspend command is issued, the WSM halts execution and sets the ESS bit high (SB6 = 1) indicating that the erase operation has been suspended. The WSM status bit also is set high (SB7 = 1) indicating that the erase-suspend operation has been completed successfully. The ESS bit remains at a logic-high level until an erase-resume command is input to the CSM (code D0h).
SB5	Erase status (ES)	1 = Block erase error 0 = Block erase good	SB5 = 0 indicates that a successful block erasure has occurred. SB5 = 1 indicates that an erase error has occurred. In this case, the WSM has completed the maximum allowed erase pulses determined by the internal algorithm, but this was insufficient to erase the device completely.
SB4	Program status (PS)	1 = Byte/word program error 0 = Byte/word program good	SB4 = 0 indicates successful programming has occurred at the addressed block location. SB4 = 1 indicates that the WSM was unable to program the addressed block location correctly.
SB3	V <sub>PP</sub> status (V <sub>PPS</sub> )	1 = Program abort: V <sub>PP</sub> range error 0 = V <sub>PP</sub> good	SB3 provides information on the status of V <sub>PP</sub> during programming. If V <sub>PP</sub> is lower than V <sub>PP_L</sub> after a program or erase command has been issued, SB3 is set to a 1 indicating that the programming operation is aborted. If V <sub>PP</sub> is between V <sub>PP_H</sub> and V <sub>PP_L</sub> , SB3 is not set.
SB2–SB0	Reserved		These bits must be masked out when reading the status register.

**byte-wide or word-wide mode selection**

The memory array is divided into two parts: an upper-half that outputs data through I/O pins DQ8–DQ15, and a lower-half that outputs data through DQ0–DQ7. Device operation in either byte-wide or word-wide mode is user-selectable and is determined by the logic state of  $\overline{\text{BYTE}}$ . When  $\overline{\text{BYTE}}$  is at a logic-high level, the device is in the word-wide mode and data is written to, or read from, I/O pins DQ0–DQ15. When  $\overline{\text{BYTE}}$  is at a logic-low level, the device is in the byte-wide mode and data is written to or read from I/O pins DQ0–DQ7. In the byte-wide mode, I/O pins DQ8–DQ14 are placed in the high-impedance state and DQ15/A<sub>–1</sub> becomes the low-order address pin and selects either the upper or lower half of the array. Array data from the upper half (DQ8–DQ15) and the lower half (DQ0–DQ7) are multiplexed to appear on DQ0–DQ7. Table 6, Table 7, and Table 8 summarize operational modes.

**TMS28F004Axy, TMS28F400Axy**  
**524288 BY 8-BIT/262144 BY 16-BIT**  
**AUTO-SELECT BOOT-BLOCK FLASH MEMORIES**

SMJS829A – JANUARY 1996 – REVISED AUGUST 1997

byte-wide or word-wide mode selection (continued)

**Table 6. Operation Modes for Word-Wide Mode ( $\overline{\text{BYTE}} = V_{IH}$ ) (see Note 2)**

MODE	$\overline{\text{WP}}$	$\overline{\text{E}}$	$\overline{\text{G}}$	$\overline{\text{RP}}$	$\overline{\text{W}}$	A9	A0	V <sub>PP</sub>	DQ0–DQ15
Read	X	V <sub>IL</sub>	V <sub>IL</sub>	V <sub>IH</sub>	V <sub>IH</sub>	X	X	X	Data out
Algorithm-selection mode	X	V <sub>IL</sub>	V <sub>IL</sub>	V <sub>IH</sub>	V <sub>IH</sub>	V <sub>ID</sub>	V <sub>IL</sub>	X	Manufacturer-equivalent code 0089h
	X	V <sub>IL</sub>	V <sub>IL</sub>	V <sub>IH</sub>	V <sub>IH</sub>	V <sub>ID</sub>	V <sub>IH</sub>	X	Device-equivalent code 4470h (top boot block) Device-equivalent code 4471h (bottom boot block)
Output disable	X	V <sub>IL</sub>	V <sub>IH</sub>	V <sub>IH</sub>	V <sub>IH</sub>	X	X	X	Hi-Z
Standby	X	V <sub>IH</sub>	X	V <sub>IH</sub>	X	X	X	X	Hi-Z
Reset/deep power down	X	X	X	V <sub>IL</sub>	X	X	X	X	Hi-Z
Write (see Note 3)	V <sub>IL</sub> or V <sub>IH</sub>	V <sub>IL</sub>	V <sub>IH</sub>	V <sub>IH</sub> or V <sub>HH</sub>	V <sub>IL</sub>	X	X	V <sub>PPL</sub> or V <sub>PPH</sub>	Data in

NOTES: 2. X = don't care

3. When writing commands to the '28F400Axy, V<sub>PP</sub> must be in the appropriate V<sub>PP</sub> voltage range (as shown in the recommended operating conditions table) for block-erase or program commands to be executed. Also, depending on the combination of RP and  $\overline{\text{WP}}$ , the boot block can be secured and, therefore, is not programmable (see Table 2 for the combinations).

**Table 7. Operation Modes for Byte-Wide Mode ( $\overline{\text{BYTE}} = V_{IL}$ ) (see Note 2)**

MODE	$\overline{\text{WP}}$	$\overline{\text{E}}$	$\overline{\text{G}}$	$\overline{\text{RP}}$	$\overline{\text{W}}$	A9	A0	V <sub>PP</sub>	DQ15/A <sub>-1</sub>	DQ8–DQ14	DQ0–DQ7
Read lower byte	X	V <sub>IL</sub>	V <sub>IL</sub>	V <sub>IH</sub>	V <sub>IH</sub>	X	X	X	V <sub>IL</sub>	Hi-Z	Data out
Read upper byte	X	V <sub>IL</sub>	V <sub>IL</sub>	V <sub>IH</sub>	V <sub>IH</sub>	X	X	X	V <sub>IH</sub>	Hi-Z	Data out
Algorithm-selection mode	X	V <sub>IL</sub>	V <sub>IL</sub>	V <sub>IH</sub>	V <sub>IH</sub>	V <sub>ID</sub>	V <sub>IL</sub>	X	X	Hi-Z	Manufacturer-equivalent code 89h
	X	V <sub>IL</sub>	V <sub>IL</sub>	V <sub>IH</sub>	V <sub>IH</sub>	V <sub>ID</sub>	V <sub>IH</sub>	X	X	Hi-Z	Device-equivalent code 70h (top boot block) Device-equivalent code 71h (bottom boot block)
Output disable	X	V <sub>IL</sub>	V <sub>IH</sub>	V <sub>IH</sub>	V <sub>IH</sub>	X	X	X	X	Hi-Z	Hi-Z
Standby	X	V <sub>IH</sub>	X	V <sub>IH</sub>	X	X	X	X	X	Hi-Z	Hi-Z
Reset/deep power down	X	X	X	V <sub>IL</sub>	X	X	X	X	X	Hi-Z	Hi-Z
Write (see Note 3)	V <sub>IL</sub> or V <sub>IH</sub>	V <sub>IL</sub>	V <sub>IH</sub>	V <sub>IH</sub> or V <sub>HH</sub>	V <sub>IL</sub>	X	X	V <sub>PPL</sub> or V <sub>PPH</sub>	X	Hi-Z	Data in

NOTES: 2. X = don't care

3. When writing commands to the '28F400Axy, V<sub>PP</sub> must be in the appropriate V<sub>PP</sub> voltage range (as shown in the recommended operating conditions table) for block-erase or program commands to be executed. Also, depending on the combination of RP and  $\overline{\text{WP}}$ , the boot block can be secured and, therefore, is not programmable (see Table 2 for the combinations).



byte-wide or word-wide mode selection (continued)

**Table 8. Operation Modes for TMS28F004Axy**

MODE	$\overline{WP}$	$\overline{E}$	$\overline{G}$	$\overline{RP}$	$\overline{W}$	A9	A0	V <sub>PP</sub>	DQ0–DQ7
Read	X	V <sub>IL</sub>	V <sub>IL</sub>	V <sub>IH</sub>	V <sub>IH</sub>	X	X	X	Data out
Algorithm-selection mode	X	V <sub>IL</sub>	V <sub>IL</sub>	V <sub>IH</sub>	V <sub>IH</sub>	V <sub>ID</sub>	V <sub>IL</sub>	X	Manufacturer-equivalent code 89h
	X	V <sub>IL</sub>	V <sub>IL</sub>	V <sub>IH</sub>	V <sub>IH</sub>	V <sub>ID</sub>	V <sub>IH</sub>	X	Device-equivalent code 78h (top boot block)
									Device-equivalent code 79h (bottom boot block)
Output disable	X	V <sub>IL</sub>	V <sub>IH</sub>	V <sub>IH</sub>	V <sub>IH</sub>	X	X	X	Hi-Z
Standby	X	V <sub>IH</sub>	X	V <sub>IH</sub>	X	X	X	X	Hi-Z
Reset/deep power down	X	X	X	V <sub>IL</sub>	X	X	X	X	Hi-Z
Write (see Note 3)	V <sub>IL</sub> or V <sub>IH</sub>	V <sub>IL</sub>	V <sub>IH</sub>	V <sub>IH</sub> or V <sub>HH</sub>	V <sub>IL</sub>	X	X	V <sub>PP</sub> L or V <sub>PP</sub> H	Data in

NOTES: 2. X = don't care

3. When writing commands to the '28F004Axy, V<sub>PP</sub> must be in the appropriate V<sub>PP</sub> voltage range (as shown in the recommended operating conditions table) for block-erase or program commands to be executed. Also, depending on the combination of  $\overline{RP}$  and  $\overline{WP}$ , the boot block can be secured and, therefore, is not programmable (see Table 2 for a list of the combinations).

**command-state machine (CSM) operations**

The CSM decodes instructions for read, read algorithm-selection code, read status register, clear status register, program, erase, erase-suspend, and erase-resume. The 8-bit command code is input to the device on DQ0–DQ7 (see Table 3 for CSM codes). During a program or erase cycle, the CSM informs the WSM that a program or erase cycle has been requested. During a program cycle, the WSM controls the program sequences and the CSM responds only to status reads.

During an erase cycle, the CSM responds to status read and erase-suspend commands. When the WSM has completed its task, the WSM status bit (SB7) is set to a logic-high level and the CSM responds to the full command set. The CSM stays in the current command state until the microprocessor issues another command.

The WSM successfully initiates an erase or program operation only when V<sub>PP</sub> is within its correct voltage range. For data protection, it is recommended that  $\overline{RP}$  be held at a logic-low level during a CPU reset.

**clear status register**

The internal circuitry can set only the V<sub>PP</sub> status (SB3), the program status bit (SB4), and the erase status bit (SB5) of the status register. The clear-status-register command (50h) allows the external microprocessor to clear these status bits and synchronize to internal operations. When the status bits are cleared, the device returns to the read array mode.

# TMS28F004Axy, TMS28F400Axy

## 524288 BY 8-BIT/262144 BY 16-BIT

### AUTO-SELECT BOOT-BLOCK FLASH MEMORIES

SMJS829A – JANUARY 1996 – REVISED AUGUST 1997

---

#### read operations

There are three read operations available: read array, read algorithm-selection code, and read status register.

- read array

The array level is read by entering the command code FFh on DQ0–DQ7. Control pins  $\overline{E}$  and  $\overline{G}$  must be at a logic-low level ( $V_{IL}$ ) and  $\overline{W}$  and  $\overline{RP}$  must be at a logic-high level ( $V_{IH}$ ) to read data from the array. Data is available on DQ0–DQ15 (word-wide mode) or DQ0–DQ7 (byte-wide mode). Any valid address within any of the blocks selects that block and allows data to be read from the block.

- read algorithm-selection code

Algorithm-selection codes are read by entering command code 90h on DQ0–DQ7. Two bus cycles are required for this operation: the first to enter the command code and a second to read the device-equivalent code. Control pins  $\overline{E}$  and  $\overline{G}$  must be at a logic-low level ( $V_{IL}$ ) and  $\overline{W}$  and  $\overline{RP}$  must be at a logic-high level ( $V_{IH}$ ). Two identifier bytes are accessed by toggling A0. The manufacturer-equivalent code is obtained on DQ0–DQ7 with A0 at a logic-low level ( $V_{IL}$ ). The device-equivalent code is obtained when A0 is set to a logic-high level ( $V_{IH}$ ). Alternatively, the manufacturer- and device-equivalent codes can be read by applying  $V_{ID}$  (nominally 12 V) to A9 and selecting the desired code by toggling A0 high or low. All other addresses are “don't cares” (see Table 4, Table 6, Table 7, Table 8).

- read status register

The status register is read by entering the command code 70h on DQ0–DQ7. Control pins  $\overline{E}$  and  $\overline{G}$  must be at a logic-low level ( $V_{IL}$ ) and  $\overline{W}$  and  $\overline{RP}$  must be at a logic-high level ( $V_{IH}$ ). Two bus cycles are required for this operation: one to enter the command code and a second to read the status register. In a given read cycle, status register contents are updated on the falling edge of  $\overline{E}$  or  $\overline{G}$ , whichever occurs last within the cycle.

#### programming operations

There are two CSM commands for programming: program setup and alternate program setup (see Table 3). After the desired command code is entered, the WSM takes over and correctly sequences the device to complete the program operation. During this time, the CSM responds only to status reads until the program operation has been completed, after which all commands to the CSM become valid again. Once a program command has been issued, the WSM normally cannot be interrupted until the program algorithm is completed (see Figure 3 and Figure 4).

Taking  $\overline{RP}$  to  $V_{IL}$  during programming aborts the program operation. During programming,  $V_{PP}$  must remain in the appropriate  $V_{PP}$  voltage range, as shown in the recommended operating conditions table. Different combinations of  $\overline{RP}$ ,  $\overline{WP}$ , and  $V_{PP}$  pin voltage levels ensure that data in certain blocks are secure, and, therefore, cannot be programmed (see Table 2 for a list of combinations). Only 0s are written and compared during a program operation. If 1s are programmed, the memory cell contents do not change and no error occurs.

A program-setup command can be aborted by writing FFh (in byte-wide mode) or FFFFh (in word-wide mode) during the second cycle. After writing all 1s during the second cycle, the CSM responds only to status reads. When the WSM status bit (SB7) is set to a logic-high level, signifying the nonprogram operation is terminated, all commands to the CSM become valid again.



## erase operations

There are two erase operations that can be performed by the TMS28F004Axy and TMS28F400Axy devices: block erase and erase suspend/erase resume. An erase operation must be used to initialize all bits in an array block to 1s. After block-erase confirm is issued, the CSM responds only to status reads or erase-suspend commands until the WSM completes its task.

- block erasure

Block erasure inside the memory array sets all bits within the addressed block to logic 1s. Erasure is accomplished only by blocks; data at single address locations within the array cannot be erased individually. The block to be erased is selected by using any valid address within that block. Note that different combinations of  $\overline{RP}$ ,  $\overline{WP}$  and  $V_{PP}$  pin voltage levels ensure that data in certain blocks are secure and, therefore, cannot be erased (see Table 2 for a list of combinations). Block erasure is initiated by a command sequence to the CSM: block-erase setup (20h) followed by block-erase confirm (D0h) (see Figure 5). A two-command erase sequence protects against accidental erasure of memory contents.

Erase setup and confirm commands are latched on the rising edge of  $\overline{E}$  or  $\overline{W}$ , whichever occurs first. Block addresses are latched during the block-erase-confirm command on the rising edge of  $\overline{E}$  or  $\overline{W}$  (see Figure 14 and Figure 15). When the block-erase-confirm command is complete, the WSM automatically executes a sequence of events to complete the block erasure. During this sequence, the block is programmed with logic 0s, data is verified, all bits in the block are erased, and finally, verification is performed to ensure that all bits are correctly erased. Monitoring of the erase operation is possible through the status register (see the subsection, "read status register").

- erase suspend/erase resume

During the execution of an erase operation, the erase-suspend command (B0h) can be entered to direct the WSM to suspend the erase operation. Once the WSM has reached the suspend state, it allows the CSM to respond only to the read-array, read-status-register, and erase-resume commands. During the erase-suspend operation, array data must be read from a block other than the one being erased. To resume the erase operation, an erase-resume command (D0h) must be issued to cause the CSM to clear the suspend state previously set (see Figure 5 and Figure 6).

## automatic power-saving mode

Substantial power savings are realized during periods when the array is not being read and the device is in the active mode. During this time, the device switches to the automatic power-saving (APS) mode. When the device switches to this mode,  $I_{CC}$  is typically reduced from 40 mA to 1 mA ( $I_{OUT} = 0$  mA). The low level of power is maintained until another read operation is initiated. In this mode, the I/O pins retain the data from the last memory address read until a new address is read. This mode is entered automatically if no address or control pins toggle within approximately a 200-ns time-out period. At least one transition on  $\overline{E}$  must occur after power up to activate this mode.

## reset/deep power-down mode

Very low levels of power consumption can be attained by using a special pin,  $\overline{RP}$ , to disable internal device circuitry. When  $\overline{RP}$  is at a CMOS logic-low level of  $0.0\text{ V} \pm 0.2\text{ V}$ , a much lower  $I_{CC}$  value or power is achievable. This is important in portable applications where extended battery life is of major concern.

A recovery time is required when exiting from deep power-down mode. For a read-array operation, a minimum of  $t_{d(RP)}$  is required before data is valid, and a minimum of  $t_{rec(RPHE)}$  and  $t_{rec(RPHW)}$  in deep power-down mode is required before data input to the CSM can be recognized. With  $\overline{RP}$  at ground, the WSM is reset and the status register is cleared, effectively eliminating accidental programming to the array during system reset. After restoration of power, the device does not recognize any operation command until  $\overline{RP}$  is returned to a  $V_{IH}$  or  $V_{HH}$  level.

# TMS28F004Axy, TMS28F400Axy 524288 BY 8-BIT/262144 BY 16-BIT AUTO-SELECT BOOT-BLOCK FLASH MEMORIES

SMJS829A – JANUARY 1996 – REVISED AUGUST 1997

---

## reset/deep power-down mode (continued)

If  $\overline{RP}$  goes low during a program or erase operation, the device powers down and, therefore, becomes nonfunctional. Data being written or erased at that time becomes invalid or indeterminate, requiring that the operation be performed again after power restoration.

## power-supply detection

$\overline{RP}$  must be connected to the system reset/power good signal to ensure that proper synchronization is maintained between the CPU and the flash memory operating modes. The default state after power up and exit from deep power-down mode is read array.  $\overline{RP}$  also is used to indicate that the power supply is stable so that the operating supply voltage can be established (3 V, 3.3 V or 5 V). Figure 10 shows the proper power-up sequence. To reset the operating supply voltage, the device must be completely powered off ( $V_{CC} = 0$  V) before the new supply voltage is detected.



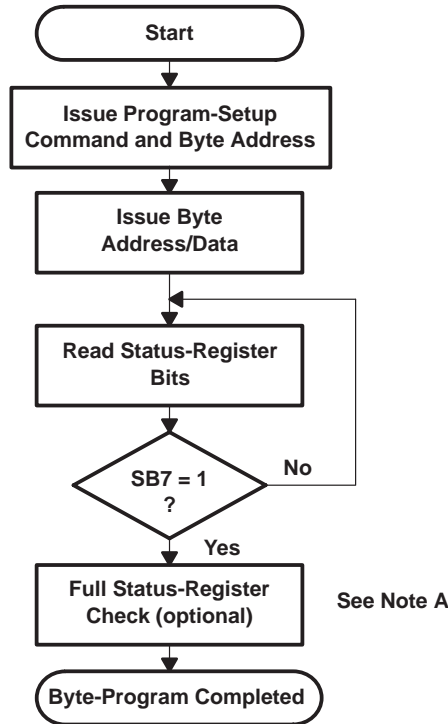

BUS OPERATION	COMMAND	COMMENTS
<i>Write</i>	Write program setup	Data = 40h or 10h Addr = Address of byte to be programmed
<i>Write</i>	Write data	Data = Byte to be programmed Addr = Address of byte to be programmed
<i>Read</i>		Status-register data. Toggle $\bar{G}$ or $\bar{E}$ to update status register.
<i>Standby</i>		Check SB7 1 = Ready, 0 = Busy
Repeat for subsequent bytes Write FFh after the last byte-programming operation to reset the device to read-array mode.		

**FULL STATUS-REGISTER-CHECK FLOW**

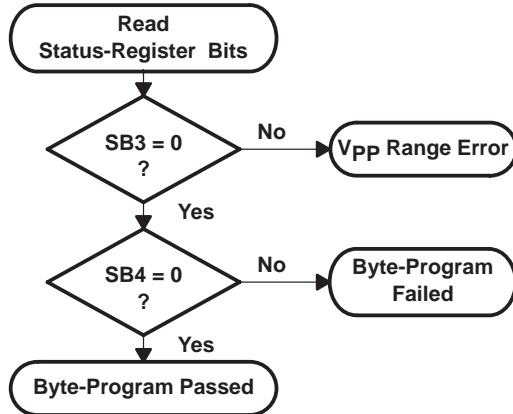

BUS OPERATION	COMMAND	COMMENTS
<i>Standby</i>		Check SB3 1 = Detect Vpp low (see Note B)
<i>Standby</i>		Check SB4 1 = Byte-program error (see Note C)

- NOTES: A. Full status-register check can be done after each word or after a sequence of words.  
 B. SB3 must be cleared before attempting additional program/erase operations.  
 C. SB4 is cleared only by the clear-status-register command, but it does not prevent additional program operation attempts.

**Figure 3. Automated Byte-Programming Flow Chart**

# TMS28F004Axy, TMS28F400Axy 524288 BY 8-BIT/262144 BY 16-BIT AUTO-SELECT BOOT-BLOCK FLASH MEMORIES

SMJS829A – JANUARY 1996 – REVISED AUGUST 1997

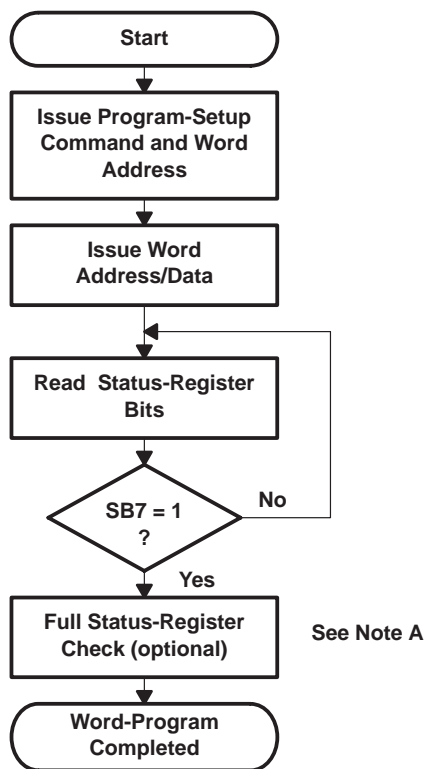

BUS OPERATION	COMMAND	COMMENTS
<i>Write</i>	Write program setup	Data = 40h or 10h Addr = Address of word to be programmed
<i>Write</i>	Write data	Data = Word to be programmed Addr = Address of word to be programmed
<i>Read</i>		Status-register data. Toggle $\bar{G}$ or $\bar{E}$ to update status register.
<i>Standby</i>		Check SB7 1 = Ready, 0 = Busy

Repeat for subsequent words.  
Write FFh after the last word-programming operation to reset the device to read-array mode.

### FULL STATUS-REGISTER-CHECK FLOW

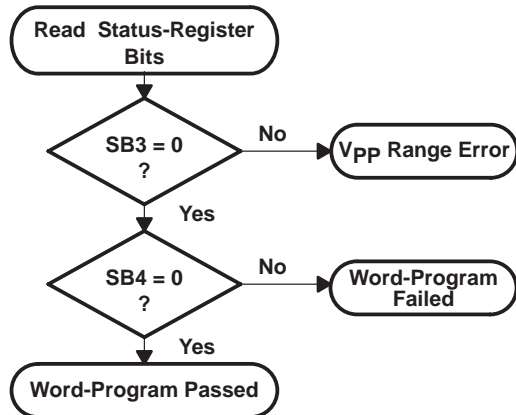

BUS OPERATION	COMMAND	COMMENTS
<i>Standby</i>		Check SB3 1 = Detect $V_{PP}$ low (see Note B)
<i>Standby</i>		Check SB4 1 = Word-program error (see Note C)

- NOTES: A. Full status-register check can be done after each word or after a sequence of words.  
 B. SB3 must be cleared before attempting additional program/erase operations.  
 C. SB4 is cleared only by the clear-status-register command, but it does not prevent additional program operation attempts.

Figure 4. Automated Word-Programming Flow Chart

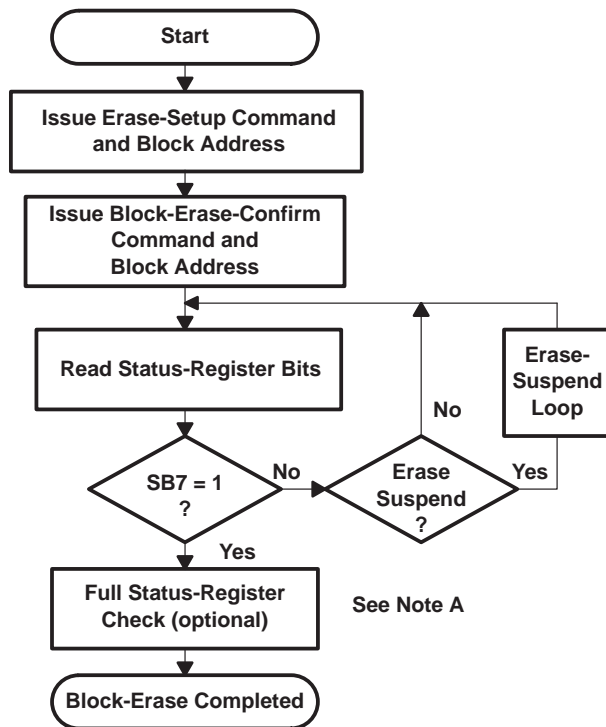

BUS OPERATION	COMMAND	COMMENTS
<i>Write</i>	Write erase setup	Data = 20h Block Addr = Address within block to be erased
<i>Write</i>	Erase	Data = D0h Block Addr = Address within block to be erased
<i>Read</i>		Status-register data. Toggle $\bar{G}$ or $\bar{E}$ to update status register
<i>Standby</i>		Check SB7 1 = Ready, 0 = Busy
Repeat for subsequent blocks Write FFh after the last block-erase operation to reset the device to read-array mode.		

**FULL STATUS-REGISTER-CHECK FLOW**

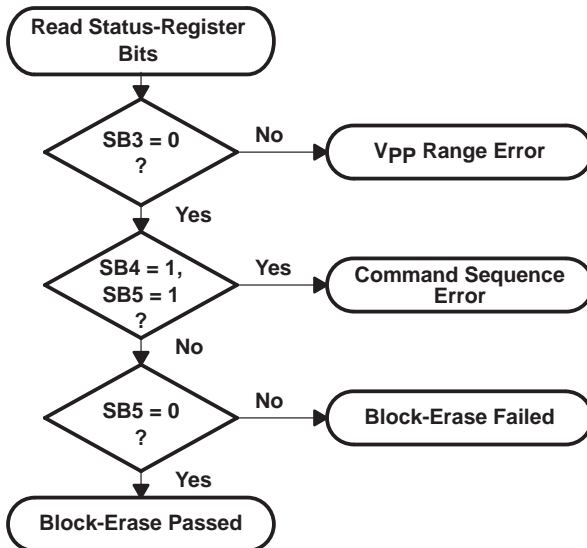

BUS OPERATION	COMMAND	COMMENTS
<i>Standby</i>		Check SB3 1 = Detect Vpp low (see Note B)
<i>Standby</i>		Check SB4 and SB5 1 = Block-erase error
<i>Standby</i>		Check SB5 1 = Block-erase error (see Note C)

- NOTES: A. Full status-register check can be done after each word or after a sequence of words.  
 B. SB3 must be cleared before attempting additional program/erase operations.  
 C. SB5 is cleared only by the clear-status-register command in cases where multiple blocks are erased before full status is checked.

**Figure 5. Automated Block-Erase Flow Chart**

**TMS28F004Axy, TMS28F400Axy**  
**524288 BY 8-BIT/262144 BY 16-BIT**  
**AUTO-SELECT BOOT-BLOCK FLASH MEMORIES**

SMJS829A – JANUARY 1996 – REVISED AUGUST 1997

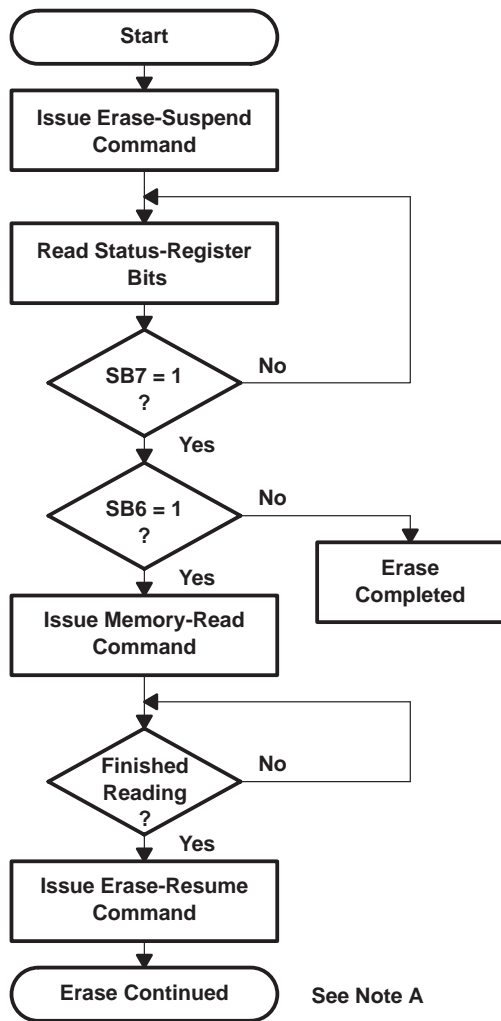

BUS OPERATION	COMMAND	COMMENTS
<i>Write</i>	Erase suspend	Data = B0h
<i>Read</i>		Status-register data. Toggle $\bar{G}$ or $\bar{E}$ to update status register.
<i>Standby</i>		Check SB7 1 = Ready
<i>Standby</i>		Check SB6 1 = Suspended
<i>Write</i>	Read memory	Data = FFh
<i>Read</i>		Read data from block other than that being erased.
<i>Write</i>	Erase resume	Data = D0h

NOTE A: See block-erase flowchart for complete erasure procedure.

**Figure 6. Erase-Suspend/Resume Flow Chart**

**absolute maximum ratings over operating free-air temperature range (unless otherwise noted)†**

Supply voltage range, $V_{CC}$ (see Note 4)	– 0.6 V to 7 V
Supply voltage range, $V_{PP}$ (see Note 4)	– 0.6 V to 14 V
Input voltage range: All inputs except $A_9, \overline{RP}$	– 0.6 V to $V_{CC} + 1$ V
$\overline{RP}, A_9$ (see Note 5)	– 0.6 V to 13.5 V
Output voltage range (see Note 6)	– 0.6 V to $V_{CC} + 1$ V
Operating free-air temperature range, $T_A$ , during read/erase/program: L suffix	0°C to 70°C
E suffix	– 40°C to 85°C
Q suffix	– 40°C to 125°C
Storage temperature range, $T_{stg}$	– 65°C to 150°C

† Stresses beyond those listed under “absolute maximum ratings” may cause permanent damage to the device. These are stress ratings only, and functional operation of the device at these or any other conditions beyond those indicated under “recommended operating conditions” is not implied. Exposure to absolute-maximum-rated conditions for extended periods may affect device reliability.

- NOTES: 4. All voltage values are with respect to  $V_{SS}$ .  
 5. The voltage on any input or output can undershoot to – 2 V for periods less than 20 ns. See Figure 8.  
 6. The voltage on any input or output can overshoot to 7 V for periods less than 20 ns. See Figure 9.

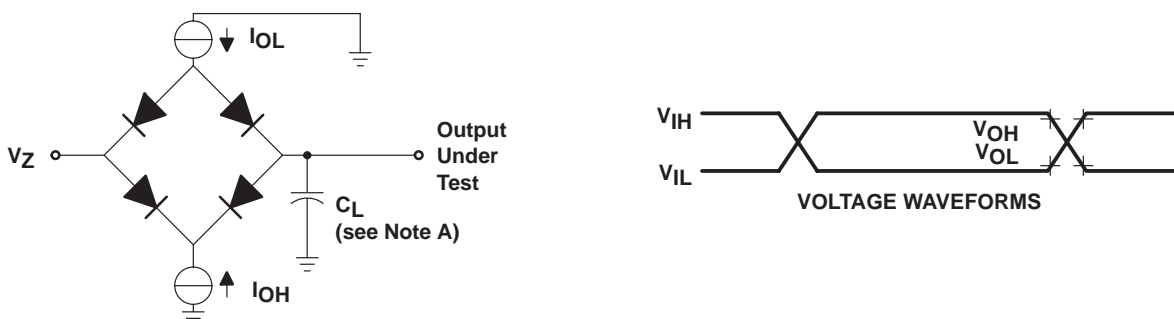

- NOTES: A.  $C_L$  includes probe and fixture capacitance.  
 B. AC test conditions are driven at  $V_{IH}$  and  $V_{IL}$ . Timing measurements are made at  $V_{OH}$  and  $V_{OL}$  levels on both inputs and outputs. See Table 9 for values based on  $V_{CC}$  operating range..  
 C. Each device must have a 0.1  $\mu$ F ceramic capacitor connected to  $V_{CC}$  and  $V_{SS}$  as close as possible to the device pins.

**Figure 7. Load Circuit and Voltage Waveforms**

**Table 9. AC Test Conditions**

$V_{CC}$ RANGE	$I_{OL}$	$I_{OH}$	$V_Z^\dagger$	$V_{OL}$	$V_{OH}$	$V_{IL}$	$V_{IH}$	$C_L$	tf	tr
5 V $\pm$ 10%	2.1	–0.4	1.5	0.8	2.0	0.45	2.4	100	< 10	< 10
3.3 $\pm$ 0.3 V	0.5	–0.5	1.5	1.5	1.5	0.0	3.0	50	< 10	< 10
2.7 to 3.6 V	0.1	–0.1	1.35	1.35	1.35	0.0	2.7	50	< 10	< 10

†  $V_Z$  is the measured value used to detect high impedance.

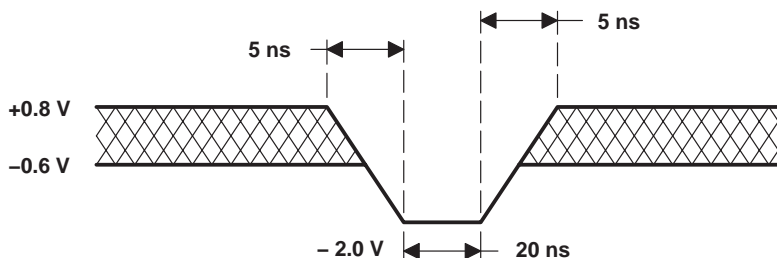

**Figure 8. Maximum Negative Overshoot Waveform**

**TMS28F004Axy, TMS28F400Axy**  
**524 288 BY 8-BIT/262 144 BY 16-BIT**  
**AUTO-SELECT BOOT-BLOCK FLASH MEMORIES**

SMJS829A – JANUARY 1996 – REVISED AUGUST 1997

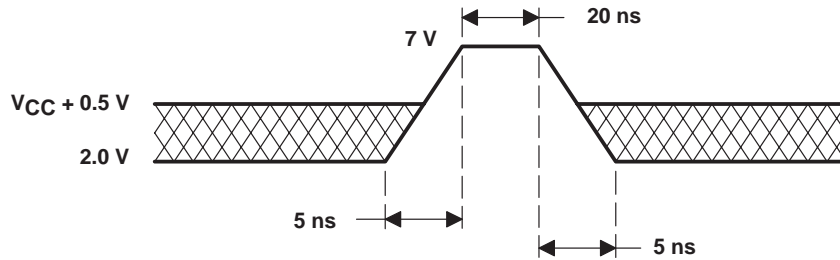

**Figure 9. Maximum Positive Overshoot Waveform**

capacitance over recommended ranges of supply voltage and operating free-air temperature

PARAMETER		TEST CONDITIONS	MIN	MAX	UNIT
C <sub>i</sub>	Input capacitance			8	pF
C <sub>o</sub>	Output capacitance	V <sub>O</sub> = 0 V		12	pF

**TMS28F004Axy, TMS28F400Axy**  
**524288 BY 8-BIT/262144 BY 16-BIT**  
**AUTO-SELECT BOOT-BLOCK FLASH MEMORIES**

SMJS829A – JANUARY 1996 – REVISED AUGUST 1997

**TMS28F004ASy and TMS28F400ASy**

The TMS28F004ASy and the TMS28F400ASy configurations have the auto-select feature that allows alternative read and program/erase voltages. Memory reads can be performed using  $V_{CC} = 3.3$  V for optimal power consumption or at  $V_{CC} = 5$  V for device performance. Erasing or programming the device can be accomplished with  $V_{PP} = 5$  V, which eliminates having to use a 12-V source and/or in-system voltage converters. Alternatively, the 12-V  $V_{PP}$  operation exists for systems that already have a 12-V power supply that provides faster programming and erasing times. This configuration is offered in two temperature ranges (0°C to 70°C and –40°C to 85°C).

**recommended operating conditions for TMS28F004ASy and TMS28F400ASy**

			MIN	NOM	MAX	UNIT	
$V_{CC}$	Supply voltage	During write/read/erase/erase suspend	3.3-V $V_{CC}$ range	3	3.3	3.6	V
			5-V $V_{CC}$ range	4.5	5	5.5	
$V_{PP}$	Supply voltage	During read only ( $V_{PPL}$ )	$V_{PPL}$	0		6.5	V
		During write/erase/erase suspend	5-V $V_{PP}$ range	4.5	5	5.5	
			12-V $V_{PP}$ range	11.4	12	12.6	
$V_{IH}$	High-level dc input voltage	3.3-V $V_{CC}$ range	TTL	2		$V_{CC} + 0.5$	V
			CMOS	$V_{CC} - 0.2$		$V_{CC} + 0.2$	
		5-V $V_{CC}$ range	TTL	2		$V_{CC} + 0.3$	
			CMOS	$V_{CC} - 0.2$		$V_{CC} + 0.2$	
$V_{IL}$	Low-level dc input voltage	3.3-V $V_{CC}$ range	TTL	– 0.5		0.8	V
			CMOS	$V_{SS} - 0.2$		$V_{SS} + 0.2$	
		5-V $V_{CC}$ range	TTL	– 0.3		0.8	
			CMOS	$V_{SS} - 0.2$		$V_{SS} + 0.2$	
$V_{LKO}$	$V_{CC}$ lock-out voltage from write/erase (see Note 7)		2			V	
$V_{HH}$	$\overline{RP}$ unlock voltage		11.4	12	13	V	
$V_{PPLK}$	$V_{PP}$ lock-out voltage from write/erase		0		1.5	V	
$T_A$	Operating free-air temperature	L Suffix	0		70	°C	
		E Suffix	– 40		85		

NOTE 7: Minimum value at  $T_A = 25^\circ\text{C}$ .

**word/byte typical write and block-erase performance for TMS28F004ASy and TMS28F400ASy (see Notes 8 and 9)**

PARAMETER	5-V $V_{PP}$ RANGE						12-V $V_{PP}$ RANGE					
	3.3-V $V_{CC}$ RANGE			5-V $V_{CC}$ RANGE			3.3-V $V_{CC}$ RANGE			5-V $V_{CC}$ RANGE		
	MIN	TYP	MAX	MIN	TYP	MAX	MIN	TYP	MAX	MIN	TYP	MAX
Main block-erase time		2.4			1.9			1.3			1.1	14
Main block-byte program time		1.7			1.4			1.6			1.2	4.2
Main block-word program time		1.1			0.9			0.8			0.6	2.1
Parameter/boot-block erase time		0.84			0.8			0.44			0.34	7

NOTES: 8. Typical values shown are at  $T_A = 25^\circ\text{C}$  and nominal conditions.

9. Excludes system-level overhead (all times in seconds)



**TMS28F004Axy, TMS28F400Axy**  
**524288 BY 8-BIT/262144 BY 16-BIT**  
**AUTO-SELECT BOOT-BLOCK FLASH MEMORIES**

SMJS829A – JANUARY 1996 – REVISED AUGUST 1997

electrical characteristics for TMS28F004ASy and TMS28F400ASy over recommended ranges of supply voltage and operating free-air temperature, using test conditions listed in Table 9 (unless otherwise noted)

PARAMETER		TEST CONDITIONS		MIN	MAX	UNIT
V <sub>OH</sub>	High-level dc output voltage	TTL	V <sub>CC</sub> = V <sub>CC</sub> MIN, I <sub>OH</sub> = – 2.5 mA	2.4		V
		CMOS	V <sub>CC</sub> = V <sub>CC</sub> MIN, I <sub>OH</sub> = – 100 μA	V <sub>CC</sub> – 0.4		
V <sub>OL</sub>	Low-level dc output voltage		V <sub>CC</sub> = V <sub>CC</sub> MIN, I <sub>OL</sub> = 5.8 mA		0.45	V
V <sub>ID</sub>	A9 selection code voltage		During read algorithm-selection mode	11.4	12.6	V
I <sub>I</sub>	Input current (leakage), except for A9 when A9 = V <sub>ID</sub> (see Note 10)		V <sub>CC</sub> = V <sub>CC</sub> MAX, V <sub>I</sub> = 0 V to V <sub>CC</sub> MAX, $\overline{RP} = V_{HH}$		±1	μA
I <sub>ID</sub>	A9 selection code current		A9 = V <sub>ID</sub>		500	μA
I <sub>RP</sub>	$\overline{RP}$ boot-block unlock current		$\overline{RP} = V_{HH}$		500	μA
I <sub>O</sub>	Output current (leakage)		V <sub>CC</sub> = V <sub>CC</sub> MAX, V <sub>O</sub> = 0 V to V <sub>CC</sub> MAX		±10	μA
I <sub>PPS</sub>	V <sub>PP</sub> standby current (standby)	V <sub>PP</sub> ≤ V <sub>CC</sub>	3.3-V V <sub>CC</sub> range		15	μA
			5-V V <sub>CC</sub> range		10	
I <sub>PPL</sub>	V <sub>PP</sub> supply current (reset/deep power-down mode)	$\overline{RP} = V_{SS} \pm 0.2$ V, V <sub>PP</sub> ≤ V <sub>CC</sub>	3.3-V V <sub>CC</sub> range		5	μA
			5-V V <sub>CC</sub> range		5	
I <sub>PP1</sub>	V <sub>PP</sub> supply current (active read)	V <sub>PP</sub> ≥ V <sub>CC</sub>	3.3-V V <sub>CC</sub> range		200	μA
			5-V V <sub>CC</sub> range		200	
I <sub>PP2</sub>	V <sub>PP</sub> supply current (active byte-write) (see Notes 11 and 12)	Programming in progress	5-V V <sub>PP</sub> range, 3.3-V V <sub>CC</sub> range		30	mA
			5-V V <sub>PP</sub> range, 5-V V <sub>CC</sub> range		25	
			12-V V <sub>PP</sub> range, 3.3-V V <sub>CC</sub> range		25	
			12-V V <sub>PP</sub> range, 5-V V <sub>CC</sub> range		20	
I <sub>PP3</sub>	V <sub>PP</sub> supply current (active word-write) (see Notes 11 and 12)	Programming in progress	5-V V <sub>PP</sub> range, 3.3-V V <sub>CC</sub> range		30	mA
			5-V V <sub>PP</sub> range, 5-V V <sub>CC</sub> range		25	
			12-V V <sub>PP</sub> range, 3.3-V V <sub>CC</sub> range		25	
			12-V V <sub>PP</sub> range, 5-V V <sub>CC</sub> range		20	
I <sub>PP4</sub>	V <sub>PP</sub> supply current (block-erase) (see Notes 11 and 12)	Block-erase in progress	5-V V <sub>PP</sub> range, 3.3-V V <sub>CC</sub> range		30	mA
			5-V V <sub>PP</sub> range, 5-V V <sub>CC</sub> range		20	
			12-V V <sub>PP</sub> range, 3.3-V V <sub>CC</sub> range		25	
			12-V V <sub>PP</sub> range, 5-V V <sub>CC</sub> range		15	

NOTES: 10. DQ15/A<sub>1</sub> is tested for output leakage only.

11. Characterization data available

12. All ac current values are RMS unless otherwise noted.



**TMS28F004Axy, TMS28F400Axy**  
**524288 BY 8-BIT/262144 BY 16-BIT**  
**AUTO-SELECT BOOT-BLOCK FLASH MEMORIES**

SMJS829A – JANUARY 1996 – REVISED AUGUST 1997

electrical characteristics for TMS28F004ASy and TMS28F400ASy over recommended ranges of supply voltage and operating free-air temperature, (as on the previous page) using test conditions listed in Table 9 (unless otherwise noted) (continued)

PARAMETER		TEST CONDITIONS	MIN	MAX	UNIT	
I <sub>PP5</sub>	V <sub>PP</sub> supply current (erase-suspend) (see Notes 11 and 12)	Block-erase suspended	5-V V <sub>PP</sub> range, 3.3-V V <sub>CC</sub> range	200	μA	
			5-V V <sub>PP</sub> range, 5-V V <sub>CC</sub> range	200		
			12-V V <sub>PP</sub> range, 3.3-V V <sub>CC</sub> range	200		
			12-V V <sub>PP</sub> range, 5-V V <sub>CC</sub> range	200		
I <sub>CCS</sub>	V <sub>CC</sub> supply current (standby)	TTL-input level	V <sub>CC</sub> = V <sub>CC</sub> MAX, E = RP = V <sub>IH</sub>	3.3-V V <sub>CC</sub> range	1.5	mA
			5-V V <sub>CC</sub> range	2	mA	
		CMOS-input level	V <sub>CC</sub> = V <sub>CC</sub> MAX, E = RP = V <sub>CC</sub> ± 0.2 V	3.3-V V <sub>CC</sub> range	110	μA
			5-V V <sub>CC</sub> range	130	μA	
I <sub>CLL</sub>	V <sub>CC</sub> supply current (reset/deep power-down mode)	RP = V <sub>SS</sub> ± 0.2 V; V <sub>CC</sub> = V <sub>CC</sub> MAX	0°C to 70°C	8	μA	
			-40°C to 85°C	8		
I <sub>CC1</sub>	V <sub>CC</sub> supply current (active read)	TTL-input level	E = V <sub>IL</sub> , I <sub>OUT</sub> = 0 mA, f = 5 MHz, G = V <sub>IH</sub>	3.3-V V <sub>CC</sub> range	30	mA
			E = V <sub>IL</sub> , I <sub>OUT</sub> = 0 mA, f = 10 MHz, G = V <sub>IH</sub>	5-V V <sub>CC</sub> range	65	
		CMOS-input level	E = V <sub>IL</sub> , I <sub>OUT</sub> = 0 mA, f = 5 MHz, G = V <sub>CC</sub>	3.3-V V <sub>CC</sub> range	30	mA
			E = V <sub>IL</sub> , I <sub>OUT</sub> = 0 mA, f = 10 MHz, G = V <sub>CC</sub>	5-V V <sub>CC</sub> range	60	
I <sub>CC2</sub>	V <sub>CC</sub> supply current (active byte write) (see Notes 11 and 12)	V <sub>CC</sub> = V <sub>CC</sub> MAX, Programming in progress	5-V V <sub>PP</sub> range, 3.3-V V <sub>CC</sub> range	30	mA	
			5-V V <sub>PP</sub> range, 5-V V <sub>CC</sub> range	50		
			12-V V <sub>PP</sub> range, 3.3-V V <sub>CC</sub> range	25		
			12-V V <sub>PP</sub> range, 5-V V <sub>CC</sub> range	45		
I <sub>CC3</sub>	V <sub>CC</sub> supply current (active word-write) (see Notes 11 and 12)	V <sub>CC</sub> = V <sub>CC</sub> MAX, Programming in progress	5-V V <sub>PP</sub> range, 3.3-V V <sub>CC</sub> range	30	mA	
			5-V V <sub>PP</sub> range, 5-V V <sub>CC</sub> range	50		
			12-V V <sub>PP</sub> range, 3.3-V V <sub>CC</sub> range	25		
			12-V V <sub>PP</sub> range, 5-V V <sub>CC</sub> range	45		

NOTES: 11. Characterization data available  
12. All ac current values are RMS unless otherwise noted.



**TMS28F004Axy, TMS28F400Axy**  
**524288 BY 8-BIT/262144 BY 16-BIT**  
**AUTO-SELECT BOOT-BLOCK FLASH MEMORIES**

SMJS829A – JANUARY 1996 – REVISED AUGUST 1997

electrical characteristics for TMS28F004ASy and TMS28F400ASy over recommended ranges of supply voltage and operating free-air temperature, (as on the previous page) using test conditions listed in Table 9 (unless otherwise noted) (continued)

PARAMETER		TEST CONDITIONS	MIN	MAX	UNIT
I <sub>CC4</sub>	V <sub>CC</sub> supply current (block-erase) (see Notes 11 and 12)	V <sub>CC</sub> = V <sub>CC</sub> MAX, Block-erase in progress	5-V V <sub>PP</sub> range, 3.3-V V <sub>CC</sub> range	30	mA
			5-V V <sub>PP</sub> range, 5-V V <sub>CC</sub> range	35	
			12-V V <sub>PP</sub> range, 3.3-V V <sub>CC</sub> range	25	
			12-V V <sub>PP</sub> range, 5-V V <sub>CC</sub> range	30	
I <sub>CC5</sub>	V <sub>CC</sub> supply current (erase suspend) (see Notes 11 and 12)	V <sub>CC</sub> = V <sub>CC</sub> MAX, $\bar{E} = V_{IH}$ , Block erase suspended	3.3-V V <sub>CC</sub> range	8	mA
			5-V V <sub>CC</sub> range	10	

NOTES: 11. Characterization data available  
 12. All ac current values are RMS unless otherwise noted.



power-up and reset switching characteristics for TMS28F004ASy and TMS28F400ASy over recommended ranges of supply voltage (commercial and extended temperature ranges)(see Notes 11, 12, and 13)

PARAMETER	ALT. SYMBOL	'28F004ASy60 '28F400ASy60				'28F004ASy70 '28F400ASy70				'28F004ASy80 '28F400ASy80				UNIT
		3.3-V VCC RANGE		5-V VCC RANGE		3.3-V VCC RANGE		5-V VCC RANGE		3.3-V VCC RANGE		5-V VCC RANGE		
		MIN	MAX	MIN	MAX	MIN	MAX	MIN	MAX	MIN	MAX	MIN	MAX	
Setup time, $\overline{RP}$ low to $V_{CC}$ at 4.5 V MIN (to $V_{CC}$ at 3 V MIN or 3.6 V MAX) (see Note 14)	$t_{PL5V}$ $t_{PL3V}$	0		0		0		0		0		0		ns
$t_a$ (DV) Address valid to data valid	$t_{AVQV}$		110		60		130		70		150		80	ns
$t_{su}$ (DV) Setup time, $\overline{RP}$ high to data valid	$t_{PHQV}$		800		450		800		450		800		450	ns
$t_h$ (RP5) Hold time, $V_{CC}$ at 4.5 V (MIN) to $\overline{RP}$ high	$t_{5VPH}$	2		2		2		2		2		2		$\mu$ s
$t_h$ (RP3) Hold time, $V_{CC}$ at 3 V (MIN) to $\overline{RP}$ high	$t_{3VPH}$	2		2		2		2		2		2		$\mu$ s

- NOTES: 11. Characterization data available  
12. All ac current values are RMS unless otherwise noted.  
13.  $\overline{E}$  and  $\overline{G}$  are switched low after power up.  
14. The power supply can switch low concurrently with  $\overline{RP}$  going low.

**TMS28F004Axy, TMS28F400Axy**  
**524288 BY 8-BIT/262144 BY 16-BIT**  
**AUTO-SELECT BOOT-BLOCK FLASH MEMORIES**

SMJS829A – JANUARY 1996 – REVISED AUGUST 1997

switching characteristics for TMS28F004ASy and TMS28F400ASy over recommended ranges of supply voltage (commercial and extended temperature ranges)

read operations

PARAMETER	ALT. SYMBOL	'28F004ASy60 '28F400ASy60				'28F004ASy70 '28F400ASy70				'28F004ASy80 '28F400ASy80				UNIT
		3.3-V VCC RANGE		5-V VCC RANGE		3.3-V VCC RANGE		5-V VCC RANGE		3.3-V VCC RANGE		5-V VCC RANGE		
		MIN	MAX	MIN	MAX	MIN	MAX	MIN	MAX	MIN	MAX	MIN	MAX	
t <sub>a</sub> (A) Access time from A0 – A17 (see Note 15)	t <sub>AVQV</sub>	110	60	130	70	150	80	150	80	150	80	ns		
t <sub>a</sub> (E) Access time from $\bar{E}$	t <sub>ELQV</sub>	110	60	130	70	150	80	150	80	150	80	ns		
t <sub>a</sub> (G) Access time from $\bar{G}$	t <sub>GLQV</sub>	65	35	80	40	90	40	90	40	90	40	ns		
t <sub>c</sub> (R) Cycle time, read	t <sub>AVAV</sub>	110	60	130	70	150	80	150	80	150	80	ns		
t <sub>d</sub> (E) Delay time, $\bar{E}$ low to low-impedance output	t <sub>ELQX</sub>	0	0	0	0	0	0	0	0	0	0	ns		
t <sub>d</sub> (G) Delay time, $\bar{G}$ low to low-impedance output	t <sub>GLQX</sub>	0	0	0	0	0	0	0	0	0	0	ns		
t <sub>dis</sub> (E) Disable time, $\bar{E}$ to high-impedance output	t <sub>EHQZ</sub>	55	25	70	30	80	30	80	30	80	30	ns		
t <sub>dis</sub> (G) Disable time, $\bar{G}$ to high-impedance output	t <sub>GHQZ</sub>	45	25	55	30	60	30	60	30	60	30	ns		
t <sub>h</sub> (D) Hold time, DQ valid from A0 – A17, $\bar{E}$ , or $\bar{G}$ , whichever occurs first (see Note 15)	t <sub>AXQX</sub>	0	0	0	0	0	0	0	0	0	0	ns		
t <sub>su</sub> (EB) Setup time, $\overline{\text{BYTE}}$ from $\bar{E}$ low	t <sub>ELFL</sub> t <sub>ELFH</sub>	5	5	5	5	5	5	5	5	5	5	ns		
t <sub>d</sub> (RP) Output delay time from $\overline{\text{RP}}$ high	t <sub>PHQV</sub>	800	450	800	450	800	450	800	450	800	450	ns		
t <sub>dis</sub> (BL) Disable time, $\overline{\text{BYTE}}$ low to DQ8 – DQ15 in high-impedance state	t <sub>FLQZ</sub>	45	25	55	30	60	30	60	30	60	30	ns		
t <sub>a</sub> (BH) Access time from $\overline{\text{BYTE}}$ going high	t <sub>FHQV</sub>	110	60	130	70	150	80	150	80	150	80	ns		

NOTE 15: A<sub>1</sub> – A<sub>17</sub> for byte-wide



**TMS28F004Axy, TMS28F400Axy**  
**524288 BY 8-BIT/262144 BY 16-BIT**  
**AUTO-SELECT BOOT-BLOCK FLASH MEMORIES**

SMJS829A – JANUARY 1996 – REVISED AUGUST 1997

**timing requirements for TMS28F004ASy and TMS28F400ASy**

**write/erase operations —  $\overline{W}$ -controlled writes**

	ALT. SYMBOL	'28F004ASy60 '28F400ASy60				'28F004ASy70 '28F400ASy70				'28F004ASy80 '28F400ASy80				UNIT
		3.3-V VCC RANGE		5-V VCC RANGE		3.3-V VCC RANGE		5-V VCC RANGE		3.3-V VCC RANGE		5-V VCC RANGE		
		MIN	MAX	MIN	MAX	MIN	MAX	MIN	MAX	MIN	MAX	MIN	MAX	
$t_c(W)$	Cycle time, write	110		60		130		70		150		80		ns
$t_c(W)_{OP}$	Cycle time, duration of programming operation	6		6		6		6		6		6		$\mu$ s
$t_c(W)_{ERB}$	Cycle time, erase operation (boot block)	0.3		0.3		0.3		0.3		0.3		0.3		s
$t_c(W)_{ERP}$	Cycle time, erase operation (parameter block)	0.3		0.3		0.3		0.3		0.3		0.3		s
$t_c(W)_{ERM}$	Cycle time, erase operation (main block)	0.6		0.6		0.6		0.6		0.6		0.6		s
$t_d(RPR)$	Delay time, boot-block reload		200		100		200		100		200		100	ns
$t_h(A)$	Hold time, A0–A17 (see Note 15)	0		0		0		0		0		0		ns
$t_h(D)$	Hold time, DQ valid	0		0		0		0		0		0		ns
$t_h(E)$	Hold time, $\overline{E}$	0		0		0		0		0		0		ns
$t_h(VPP)$	Hold time, Vpp from valid status register bit	0		0		0		0		0		0		ns
$t_h(RP)$	Hold time, $\overline{RP}$ at V <sub>HH</sub> from valid status register bit	0		0		0		0		0		0		ns
$t_h(WP)$	Hold time, $\overline{WP}$ from valid status register bit	0		0		0		0		0		0		ns
$t_{su}(WP)$	Setup time, $\overline{WP}$ before write operation	90		50		105		50		120		50		ns
$t_{su}(A)$	Setup time, A0–A17 (see Note 15)	90		50		105		50		120		50		ns
$t_{su}(D)$	Setup time, DQ	90		50		105		50		120		50		ns
$t_{su}(E)$	Setup time, $\overline{E}$ before write operation	0		0		0		0		0		0		ns

NOTE 15: A<sub>n-1</sub>–A17 for byte-wide



**TMS28F004Axy, TMS28F400Axy**  
**524288 BY 8-BIT/262144 BY 16-BIT**  
**AUTO-SELECT BOOT-BLOCK FLASH MEMORIES**  
 SMJS829A – JANUARY 1996 – REVISED AUGUST 1997

**timing requirements for TMS28F004ASy and TMS28F400ASy (continued)**  
**write/erase operations —  $\overline{W}$ -controlled writes**

	ALT. SYMBOL	'28F004ASy60 '28F400ASy60		'28F004ASy70 '28F400ASy70		'28F004ASy80 '28F400ASy80		UNIT		
		3.3-V V <sub>CC</sub> RANGE		5-V V <sub>CC</sub> RANGE		3.3-V V <sub>CC</sub> RANGE			5-V V <sub>CC</sub> RANGE	
		MIN	MAX	MIN	MAX	MIN	MAX		MIN	MAX
t <sub>su</sub> (RP)	Setup time, $\overline{RP}$ at V <sub>HH</sub> to $\overline{W}$ going high	200	100	200	100	200	100	ns		
t <sub>su</sub> (VPP)1	Setup time, V <sub>pp</sub> to $\overline{W}$ going high	200	100	200	100	200	100	ns		
t <sub>w</sub> (W)	Pulse duration, $\overline{W}$ low	90	50	105	50	120	50	ns		
t <sub>w</sub> (WH)	Pulse duration, $\overline{W}$ high	20	10	25	20	30	30	ns		
t <sub>rec</sub> (RPHW)	Recovery time, $\overline{RP}$ high to $\overline{W}$ going low	800	450	800	450	800	450	ns		



timing requirements for TMS28F004ASy and TMS28F400ASy

write/erase operations — E-controlled writes

	ALT. SYMBOL	'28F004ASy60 '28F400ASy60				'28F004ASy70 '28F400ASy70				'28F004ASy80 '28F400ASy80				UNIT
		3.3-V VCC RANGE		5-V VCC RANGE		3.3-V VCC RANGE		5-V VCC RANGE		3.3-V VCC RANGE		5-V VCC RANGE		
		MIN	MAX	MIN	MAX	MIN	MAX	MIN	MAX	MIN	MAX	MIN	MAX	
t <sub>c</sub> (E)	t <sub>AVAV</sub>	110		60		130		70		150		80		ns
t <sub>c</sub> (E)OP	t <sub>EHQV1</sub>	6		6		6		6		6		6		μs
t <sub>c</sub> (E)ERB	t <sub>EHQV2</sub>	0.3		0.3		0.3		0.3		0.3		0.3		s
t <sub>c</sub> (E)ERP	t <sub>EHQV3</sub>	0.3		0.3		0.3		0.3		0.3		0.3		s
t <sub>c</sub> (E)ERM	t <sub>EHQV4</sub>	0.6		0.6		0.6		0.6		0.6		0.6		s
t <sub>d</sub> (RPR)	t <sub>PHBR</sub>		200		100		200		100		200		100	ns
t <sub>h</sub> (A)	t <sub>EHAX</sub>	0		0		0		0		0		0		ns
t <sub>h</sub> (D)	t <sub>EHDX</sub>	0		0		0		0		0		0		ns
t <sub>h</sub> (W)	t <sub>EHWH</sub>	0		0		0		0		0		0		ns
t <sub>h</sub> (VPP)	t <sub>QVVL</sub>	0		0		0		0		0		0		ns
t <sub>h</sub> (RP)	t <sub>QVPH</sub>	0		0		0		0		0		0		ns
t <sub>h</sub> (WP)	t <sub>WHPL</sub>	0		0		0		0		0		0		ns
t <sub>su</sub> (WP)	t <sub>ELPH</sub>	90		50		105		50		120		50		ns
t <sub>su</sub> (A)	t <sub>AVEH</sub>	90		50		105		50		120		50		ns
t <sub>su</sub> (D)	t <sub>DVEH</sub>	90		50		105		50		120		50		ns
t <sub>su</sub> (W)	t <sub>WLEL</sub>	0		0		0		0		0		0		ns

NOTE 15: A<sub>1</sub>–A<sub>17</sub> for byte-wide

**TMS28F004Axy, TMS28F400Axy**  
**524288 BY 8-BIT/262144 BY 16-BIT**  
**AUTO-SELECT BOOT-BLOCK FLASH MEMORIES**

SMJS829A – JANUARY 1996 – REVISED AUGUST 1997

**timing requirements for TMS28F004ASy and TMS28F400ASy (continued)**

**write/erase operations —  $\bar{E}$ -controlled writes**

	ALT. SYMBOL	'28F004ASy60 '28F400ASy60		'28F004ASy70 '28F400ASy70		'28F004ASy80 '28F400ASy80		UNIT		
		3.3-V VCC RANGE		5-V VCC RANGE		3.3-V VCC RANGE			5-V VCC RANGE	
		MIN	MAX	MIN	MAX	MIN	MAX		MIN	MAX
$t_{su}(RP)$	Setup time, $\overline{RP}$ at $V_{HH}$ to $\bar{E}$ going high	200	100	200	100	200	100	ns		
$t_{su}(VPP)2$	Setup time, $V_{pp}$ to $\bar{E}$ going high	200	100	200	100	200	100	ns		
$t_{w}(E)$	Pulse duration, $\bar{E}$ low	90	50	105	50	120	50	ns		
$t_{w}(EH)$	Pulse duration, $\bar{E}$ high	20	10	25	20	30	30	ns		
$t_{rec}(RPHE)$	Recovery time, $\overline{RP}$ high to $\bar{E}$ going low	800	450	800	450	800	450	ns		



**TMS28F004Axy, TMS28F400Axy**  
**524288 BY 8-BIT/262144 BY 16-BIT**  
**AUTO-SELECT BOOT-BLOCK FLASH MEMORIES**

SMJS829A – JANUARY 1996 – REVISED AUGUST 1997

**TMS28F004AEy and TMS28F400AEy**

The TMS28F004AEy and the TMS28F400AEy configurations offer the auto-select feature of the TMS28F400ASy with an extended  $V_{CC}$  from a low 2.7-V to 3.6-V range (3-V nominal). Memory reads can be performed using a  $V_{CC} = 3$  V, allowing for more efficient power consumption than the 'ASy device.

**recommended operating conditions for TMS28F004AEy and TMS28F400AEy**

			MIN	NOM	MAX	UNIT	
$V_{CC}$	Supply voltage	During write/read/erase/erase suspend	3-V $V_{CC}$ range	2.7	3	3.6	V
			5-V $V_{CC}$ range	4.5	5	5.5	
$V_{PP}$	Supply voltage	During read only ( $V_{PPL}$ )	$V_{PPL}$	0	6.5	V	
		During write/erase/erase suspend	5-V $V_{PP}$ range	4.5	5		5.5
			12-V $V_{PP}$ range	11.4	12		12.6
$V_{IH}$	High-level dc input voltage	3-V $V_{CC}$ range	TTL	2	$V_{CC} + 0.5$	V	
			CMOS	$V_{CC} - 0.2$	$V_{CC} + 0.2$		
		5-V $V_{CC}$ range	TTL	2	$V_{CC} + 0.3$		
			CMOS	$V_{CC} - 0.2$	$V_{CC} + 0.2$		
$V_{IL}$	Low-level dc input voltage	3-V $V_{CC}$ range	TTL	-0.5	0.8	V	
			CMOS	$V_{SS} - 0.2$	$V_{SS} + 0.2$		
		5-V $V_{CC}$ range	TTL	-0.3	0.8		
			CMOS	$V_{SS} - 0.2$	$V_{SS} + 0.2$		
$V_{LKO}$	$V_{CC}$ lock-out voltage from write/erase (see Note 7)		2			V	
$V_{HH}$	$\overline{RP}$ unlock voltage		11.4	12	13	V	
$V_{PPLK}$	$V_{PP}$ lock-out voltage from write/erase		0		1.5	V	
$T_A$	Operating free-air temperature	L Suffix	0		70	°C	
		E Suffix	-40		85		

NOTE 7: Minimum value at  $T_A = 25^\circ\text{C}$ .

**word/byte typical write and block-erase performance for TMS28F004AEy and TMS28F400AEy (see Notes 8 and 9)**

PARAMETER	5-V $V_{PP}$ RANGE						12-V $V_{PP}$ RANGE					
	3-V $V_{CC}$ RANGE			5-V $V_{CC}$ RANGE			3-V $V_{CC}$ RANGE			5-V $V_{CC}$ RANGE		
	MIN	TYP	MAX	MIN	TYP	MAX	MIN	TYP	MAX	MIN	TYP	MAX
Main block-erase time	2.4			1.9			1.3			1.1 14		
Main block-byte program time	1.7			1.4			1.6			1.2 4.2		
Main block-word program time	1.1			0.9			0.8			0.6 2.1		
Parameter/boot-block erase time	0.84			0.8			0.44			0.34 7		

NOTES: 8. Typical values shown are at  $T_A = 25^\circ\text{C}$  and nominal conditions.

9. Excludes system-level overhead (all times in seconds)



**TMS28F004Axy, TMS28F400Axy**  
**524288 BY 8-BIT/262144 BY 16-BIT**  
**AUTO-SELECT BOOT-BLOCK FLASH MEMORIES**

SMJS829A – JANUARY 1996 – REVISED AUGUST 1997

electrical characteristics for TMS28F004AEy and TMS28F400AEy over recommended ranges of supply voltage and operating free-air temperature using test conditions listed in Table 9 (unless otherwise noted)

PARAMETER		TEST CONDITIONS	MIN	MAX	UNIT	
V <sub>OH</sub>	High-level dc output voltage	TTL	V <sub>CC</sub> = V <sub>CC</sub> MIN, I <sub>OH</sub> = - 2.5 mA		V	
		CMOS	V <sub>CC</sub> = V <sub>CC</sub> MIN, I <sub>OH</sub> = - 100 μA			
V <sub>OL</sub>	Low-level dc output voltage	V <sub>CC</sub> = V <sub>CC</sub> MIN, I <sub>OL</sub> = 5.8 mA		0.45	V	
V <sub>ID</sub>	A9 selection code voltage	During read algorithm-selection mode		11.4	12.6	V
I <sub>I</sub>	Input current (leakage), except for A9 when A9 = V <sub>ID</sub> (see Note 10)	V <sub>CC</sub> = V <sub>CC</sub> MAX, V <sub>I</sub> = 0 V to V <sub>CC</sub> MAX, $\overline{RP} = V_{HH}$		±1		μA
I <sub>ID</sub>	A9 selection code current	A9 = V <sub>ID</sub>		500		μA
I <sub>RP</sub>	$\overline{RP}$ boot-block unlock current	$\overline{RP} = V_{HH}$		500		μA
I <sub>O</sub>	Output current (leakage)	V <sub>CC</sub> = V <sub>CC</sub> MAX, V <sub>O</sub> = 0 V to V <sub>CC</sub> MAX		±10		μA
I <sub>PPS</sub>	V <sub>PP</sub> standby current (standby)	V <sub>PP</sub> ≤ V <sub>CC</sub>	3-V V <sub>CC</sub> range	15		μA
			5-V V <sub>CC</sub> range	10		
I <sub>PPL</sub>	V <sub>PP</sub> supply current (reset/deep power-down mode)	$\overline{RP} = V_{SS} \pm 0.2 V, V_{PP} \leq V_{CC}$	3-V V <sub>CC</sub> range	5		μA
			5-V V <sub>CC</sub> range	5		
I <sub>PP1</sub>	V <sub>PP</sub> supply current (active read)	V <sub>PP</sub> ≥ V <sub>CC</sub>	3-V V <sub>CC</sub> range	200		μA
			5-V V <sub>CC</sub> range	200		
I <sub>PP2</sub>	V <sub>PP</sub> supply current (active byte-write) (see Notes 11 and 12)	Programming in progress	5-V V <sub>PP</sub> range, 3-V V <sub>CC</sub> range	30		mA
			5-V V <sub>PP</sub> range, 5-V V <sub>CC</sub> range	25		
			12-V V <sub>PP</sub> range, 3-V V <sub>CC</sub> range	25		
			12-V V <sub>PP</sub> range, 5-V V <sub>CC</sub> range	20		
I <sub>PP3</sub>	V <sub>PP</sub> supply current (active word-write) (see Notes 11 and 12)	Programming in progress	5-V V <sub>PP</sub> range, 3-V V <sub>CC</sub> range	30		mA
			5-V V <sub>PP</sub> range, 5-V V <sub>CC</sub> range	25		
			12-V V <sub>PP</sub> range, 3-V V <sub>CC</sub> range	25		
			12-V V <sub>PP</sub> range, 5-V V <sub>CC</sub> range	20		

NOTES: 10. DQ15/A<sub>-1</sub> is tested for output leakage only.

11. Characterization data available

12. All ac current values are RMS unless otherwise noted.



**TMS28F004Axy, TMS28F400Axy**  
**524288 BY 8-BIT/262144 BY 16-BIT**  
**AUTO-SELECT BOOT-BLOCK FLASH MEMORIES**

SMJS829A – JANUARY 1996 – REVISED AUGUST 1997

electrical characteristics for TMS28F004AEy and TMS28F400AEy over recommended ranges of supply voltage and operating free-air temperature using test conditions given in Table 9 (unless otherwise noted) (continued)

PARAMETER		TEST CONDITIONS		MIN	MAX	UNIT
I <sub>PP4</sub>	V <sub>PP</sub> supply current (block-erase) (see Notes 11 and 12)	Block-erase in progress	5-V V <sub>PP</sub> range, 3-V V <sub>CC</sub> range		30	mA
			5-V V <sub>PP</sub> range, 5-V V <sub>CC</sub> range		20	
			12-V V <sub>PP</sub> range, 3-V V <sub>CC</sub> range		25	mA
			12-V V <sub>PP</sub> range, 5-V V <sub>CC</sub> range		15	
I <sub>PP5</sub>	V <sub>PP</sub> supply current (erase-suspend) (see Notes 11 and 12)	Block-erase suspended	5-V V <sub>PP</sub> range, 3-V V <sub>CC</sub> range		200	μA
			5-V V <sub>PP</sub> range, 5-V V <sub>CC</sub> range		200	
			12-V V <sub>PP</sub> range, 3-V V <sub>CC</sub> range		200	μA
			12-V V <sub>PP</sub> range, 5-V V <sub>CC</sub> range		200	
I <sub>CCS</sub>	V <sub>CC</sub> supply current (standby)	TTL-input level	V <sub>CC</sub> = V <sub>CC</sub> MAX E = RP = V <sub>IH</sub>	3-V V <sub>CC</sub> range	1.5	mA
			5-V V <sub>CC</sub> range	2		
		CMOS-input level	V <sub>CC</sub> = V <sub>CC</sub> MAX, E = RP = WP = V <sub>CC</sub> ± 0.2 V	3-V V <sub>CC</sub> range	110	μA
			5-V V <sub>CC</sub> range	130		
I <sub>CCL</sub>	V <sub>CC</sub> supply current (reset/deep power-down mode)	RP = V <sub>SS</sub> ± 0.2 V; V <sub>CC</sub> = V <sub>CC</sub> MAX	0°C to 70°C	8	μA	
			-40°C to 85°C	8		
I <sub>CC1</sub>	V <sub>CC</sub> supply current (active read)	TTL-input level	E = V <sub>IL</sub> , I <sub>OUT</sub> = 0 mA, f = 5 MHz, G = V <sub>IH</sub>	3.3-V V <sub>CC</sub> range	30	mA
			E = V <sub>IL</sub> , I <sub>OUT</sub> = 0 mA, f = 10 MHz, G = V <sub>IH</sub>	5-V V <sub>CC</sub> range	65	
		CMOS-input level	E = V <sub>IL</sub> , I <sub>OUT</sub> = 0 mA, f = 5 MHz, G = V <sub>CC</sub>	3.3-V V <sub>CC</sub> range	30	mA
			E = V <sub>IL</sub> , I <sub>OUT</sub> = 0 mA, f = 10 MHz, G = V <sub>CC</sub>	5-V V <sub>CC</sub> range	60	
I <sub>CC2</sub>	V <sub>CC</sub> supply current (active byte-write) (see Notes 11 and 12)	V <sub>CC</sub> = V <sub>CC</sub> MAX, Programming in progress	5-V V <sub>PP</sub> range, 3-V V <sub>CC</sub> range		30	mA
			5-V V <sub>PP</sub> range, 5-V V <sub>CC</sub> range		50	
			12-V V <sub>PP</sub> range, 3-V V <sub>CC</sub> range		25	
			12-V V <sub>PP</sub> range, 5-V V <sub>CC</sub> range		45	

NOTES: 11. Characterization data available

12. All ac current values are RMS unless otherwise noted.



**TMS28F004Axy, TMS28F400Axy**  
**524288 BY 8-BIT/262144 BY 16-BIT**  
**AUTO-SELECT BOOT-BLOCK FLASH MEMORIES**

SMJS829A – JANUARY 1996 – REVISED AUGUST 1997

electrical characteristics for TMS28F004AEy and TMS28F400AEy over recommended ranges of supply voltage and operating free-air temperature using test conditions given in Table 9 (unless otherwise noted) (continued)

PARAMETER		TEST CONDITIONS	MIN	MAX	UNIT
I <sub>CC3</sub>	V <sub>CC</sub> supply current (active word-write) (see Notes 11 and 12)	V <sub>CC</sub> = V <sub>CC</sub> MAX, Programming in progress	5-V V <sub>PP</sub> range, 3-V V <sub>CC</sub> range	30	mA
			5-V V <sub>PP</sub> range, 3-V V <sub>CC</sub> range	50	
			12-V V <sub>PP</sub> range, 3-V V <sub>CC</sub> range	25	
			12-V V <sub>PP</sub> range, 5-V V <sub>CC</sub> range	45	
I <sub>CC4</sub>	V <sub>CC</sub> supply current (block-erase) (see Notes 11 and 12)	V <sub>CC</sub> = V <sub>CC</sub> MAX, Block-erase in progress	5-V V <sub>PP</sub> range, 3-V V <sub>CC</sub> range	30	mA
			5-V V <sub>PP</sub> range, 5-V V <sub>CC</sub> range	35	
			12-V V <sub>PP</sub> range, 3-V V <sub>CC</sub> range	25	
			12-V V <sub>PP</sub> range, 5-V V <sub>CC</sub> range	30	
I <sub>CC5</sub>	V <sub>CC</sub> supply current (erase-suspend) (see Notes 11 and 12)	V <sub>CC</sub> = V <sub>CC</sub> MAX, $\bar{E} = V_{IH}$ , Block-erase suspended	3-V V <sub>CC</sub> range		mA
			3.3-V V <sub>CC</sub> range	8	
			5-V V <sub>CC</sub> range	10	

NOTES: 11. Characterization data available  
12. All ac current values are RMS unless otherwise noted.



**TMS28F004Axy, TMS28F400Axy**  
**524288 BY 8-BIT/262144 BY 16-BIT**  
**AUTO-SELECT BOOT-BLOCK FLASH MEMORIES**

SMJS829A – JANUARY 1996 – REVISED AUGUST 1997

power-up and reset switching characteristics for TMS28F004AEy and TMS28F400AEy over recommended ranges of supply voltage (commercial and extended temperature ranges) (see Notes 11, 12, and 13)

PARAMETER	ALT. SYMBOL	'28F004AEy60 '28F400AEy60				UNIT
		3-V V <sub>CC</sub> RANGE		5-V V <sub>CC</sub> RANGE		
		MIN	MAX	MIN	MAX	
t <sub>su</sub> (VCC) Setup time, $\overline{RP}$ low to V <sub>CC</sub> at 4.5 V MIN (to V <sub>CC</sub> at 2.7 V MIN or 3.6 V MAX) (see Note 14)	t <sub>PL5V</sub> t <sub>PL3V</sub>	0		0		ns
t <sub>a</sub> (DV) Address valid to data valid	t <sub>AVQV</sub>		110		60	ns
t <sub>su</sub> (DV) Setup time, $\overline{RP}$ high to data valid	t <sub>PHQV</sub>		800		450	ns
t <sub>h</sub> (RP5) Hold time, V <sub>CC</sub> at 4.5 V (MIN) to $\overline{RP}$ high	t <sub>5VPH</sub>		2		2	μs
t <sub>h</sub> (RP3) Hold time, V <sub>CC</sub> at 2.7 V (MIN) to $\overline{RP}$ high	t <sub>3VPH</sub>		2		2	μs

PARAMETER	ALT. SYMBOL	'28F004AEy70 '28F400AEy70				'28F004AEy80 '28F400AEy80				UNIT
		3-V V <sub>CC</sub> RANGE		5-V V <sub>CC</sub> RANGE		3-V V <sub>CC</sub> RANGE		5-V V <sub>CC</sub> RANGE		
		MIN	MAX	MIN	MAX	MIN	MAX	MIN	MAX	
t <sub>su</sub> (VCC) Setup time, $\overline{RP}$ low to V <sub>CC</sub> at 4.5 V MIN (to V <sub>CC</sub> at 2.7 V MIN or 3.6 V MAX) (see Note 14)	t <sub>PL5V</sub> t <sub>PL3V</sub>	0		0		0		0		ns
t <sub>a</sub> (DV) Address valid to data valid	t <sub>AVQV</sub>		150		70		150		80	ns
t <sub>su</sub> (DV) Setup time, $\overline{RP}$ high to data valid	t <sub>PHQV</sub>		800		450		800		450	ns
t <sub>h</sub> (RP5) Hold time, V <sub>CC</sub> at 4.5 V (MIN) to $\overline{RP}$ high	t <sub>5VPH</sub>		2		2		2		2	μs
t <sub>h</sub> (RP3) Hold time, V <sub>CC</sub> at 2.7 V (MIN) to $\overline{RP}$ high	t <sub>3VPH</sub>		2		2		2		2	μs

- NOTES: 11. Characterization data available  
12. All ac current values are RMS unless otherwise noted.  
13.  $\overline{E}$  and  $\overline{G}$  are switched low after power up.  
14. The power supply can switch low concurrently with  $\overline{RP}$  going low.



**TMS28F004Axy, TMS28F400Axy**  
**524288 BY 8-BIT/262144 BY 16-BIT**  
**AUTO-SELECT BOOT-BLOCK FLASH MEMORIES**

SMJS829A – JANUARY 1996 – REVISED AUGUST 1997

switching characteristics for TMS28F004AEy and TMS28F400AEy over recommended ranges of supply voltage (commercial and extended temperature ranges)

read operations

PARAMETER	ALT. SYMBOL	'28F004AEy 60 '28F400AEy 60				'28F004AEy 70 '28F400AEy 70				UNIT
		3-V V <sub>CC</sub> RANGE		5-V V <sub>CC</sub> RANGE		3-V V <sub>CC</sub> RANGE		5-V V <sub>CC</sub> RANGE		
		MIN	MAX	MIN	MAX	MIN	MAX	MIN	MAX	
t <sub>a</sub> (A) Access time from A0–A17 (see Note 15)	t <sub>AVQV</sub>	110		60		130		70		ns
t <sub>a</sub> (E) Access time from $\bar{E}$	t <sub>ELQV</sub>	110		60		130		70		ns
t <sub>a</sub> (G) Access time from $\bar{G}$	t <sub>GLQV</sub>	65		35		80		40		ns
t <sub>c</sub> (R) Cycle time, read	t <sub>AVAV</sub>	110		60		130		70		ns
t <sub>d</sub> (E) Delay time, $\bar{E}$ low to low-impedance output	t <sub>ELQX</sub>	0		0		0		0		ns
t <sub>d</sub> (G) Delay time, $\bar{G}$ low to low-impedance output	t <sub>GLQX</sub>	0		0		0		0		ns
t <sub>dis</sub> (E) Disable time, $\bar{E}$ to high-impedance output	t <sub>EHQZ</sub>	55		25		70		30		ns
t <sub>dis</sub> (G) Disable time, $\bar{G}$ to high-impedance output	t <sub>GHQZ</sub>	45		25		55		30		ns
t <sub>h</sub> (D) Hold time, DQ valid from A0–A17, $\bar{E}$ , or $\bar{G}$ , whichever occurs first (see Note 15)	t <sub>AXQX</sub>	0		0		0		0		ns
t <sub>su</sub> (EB) Setup time, $\overline{BYTE}$ from $\bar{E}$ low	t <sub>ELFL</sub> t <sub>ELFH</sub>	5		5		5		5		ns
t <sub>d</sub> (RP) Output delay time from $\overline{RP}$ high	t <sub>PHQV</sub>	800		450		800		450		ns
t <sub>dis</sub> (BL) Disable time, $\overline{BYTE}$ low to DQ8–DQ15 in the high-impedance state	t <sub>FLQZ</sub>	45		25		55		30		ns
t <sub>a</sub> (BH) Access time from $\overline{BYTE}$ going high	t <sub>FHQV</sub>	110		60		130		70		ns

NOTE 15: A<sub>1</sub>–A17 for byte-wide

**TMS28F004Axy, TMS28F400Axy**  
**524288 BY 8-BIT/262144 BY 16-BIT**  
**AUTO-SELECT BOOT-BLOCK FLASH MEMORIES**

SMJS829A – JANUARY 1996 – REVISED AUGUST 1997

switching characteristics for TMS28F004AEy and TMS28F400AEy over recommended ranges of supply voltage (commercial and extended temperature ranges) (continued)

PARAMETER	ALT. SYMBOL	'28F004AEy80 '28F400AEy80				UNIT
		3-V $V_{CC}$ RANGE		5-V $V_{CC}$ RANGE		
		MIN	MAX	MIN	MAX	
$t_{a(A)}$ Access time from A0–A17 (see Note 15)	$t_{AVQV}$	150		80		ns
$t_{a(E)}$ Access time from $\overline{E}$	$t_{ELQV}$	150		80		ns
$t_{a(G)}$ Access time from $\overline{G}$	$t_{GLQV}$	90		40		ns
$t_{c(R)}$ Cycle time, read	$t_{AVAV}$	150		80		ns
$t_{d(E)}$ Delay time, $\overline{E}$ low to low-impedance output	$t_{ELQX}$	0		0		ns
$t_{d(G)}$ Delay time, $\overline{G}$ low to low-impedance output	$t_{GLQX}$	0		0		ns
$t_{dis(E)}$ Disable time, $\overline{E}$ to high-impedance output	$t_{EHQZ}$	80		30		ns
$t_{dis(G)}$ Disable time, $\overline{G}$ to high-impedance output	$t_{GHQZ}$	60		30		ns
$t_{h(D)}$ Hold time, DQ valid from A0–A17, $\overline{E}$ , or $\overline{G}$ , whichever occurs first (see Note 15)	$t_{AXQX}$	0		0		ns
$t_{su(EB)}$ Setup time, $\overline{BYTE}$ from $\overline{E}$ low	$t_{ELFL}$ $t_{ELFH}$	5		5		ns
$t_{d(RP)}$ Output delay time from $\overline{RP}$ high	$t_{PHQV}$	800		450		ns
$t_{dis(BL)}$ Disable time, $\overline{BYTE}$ low to DQ8–DQ15 in the high-impedance state	$t_{FLQZ}$	60		30		ns
$t_{a(BH)}$ Access time from $\overline{BYTE}$ going high	$t_{FHQV}$	150		80		ns

NOTE 15: A<sub>1</sub>–A17 for byte-wide

**TMS28F004Axy, TMS28F400Axy**  
**524288 BY 8-BIT/262144 BY 16-BIT**  
**AUTO-SELECT BOOT-BLOCK FLASH MEMORIES**

SMJS829A – JANUARY 1996 – REVISED AUGUST 1997

**timing requirements for TMS28F004AEy and TMS28F400AEy**

**write/erase operations —  $\overline{W}$ -controlled writes**

	ALT. SYMBOL	'28F004AEy 60 '28F400AEy 60				UNIT
		3-V VCC RANGE		5-V VCC RANGE		
		MIN	MAX	MIN	MAX	
$t_{c(W)}$ Cycle time, write	$t_{AVAV}$	110		60		ns
$t_{c(W)OP}$ Cycle time, duration of programming operation	$t_{WHQV1}$	6		6		$\mu$ s
$t_{c(W)ERB}$ Cycle time, erase operation (boot block)	$t_{WHQV2}$	0.3		0.3		s
$t_{c(W)ERP}$ Cycle time, erase operation (parameter block)	$t_{WHQV3}$	0.3		0.3		s
$t_{c(W)ERM}$ Cycle time, erase operation (main block)	$t_{WHQV4}$	0.6		0.6		s
$t_d(RPR)$ Delay time, boot-block relock	$t_{PHBR}$		200		100	ns
$t_h(A)$ Hold time, A0–A17 (see Note 15)	$t_{WHAX}$	0		0		ns
$t_h(D)$ Hold time, DQ valid	$t_{WHDX}$	0		0		ns
$t_h(E)$ Hold time, $\overline{E}$	$t_{WHEH}$	0		0		ns
$t_h(VPP)$ Hold time, $V_{PP}$ from valid status register bit	$t_{QVVL}$	0		0		ns
$t_h(RP)$ Hold time, $\overline{RP}$ at $V_{HH}$ from valid status register bit	$t_{QVPH}$	0		0		ns
$t_h(WP)$ Hold time, $\overline{WP}$ from valid status register bit	$t_{WHPL}$	0		0		ns
$t_{su(WP)}$ Setup time, $\overline{WP}$ before write operation	$t_{ELPH}$	90		50		ns
$t_{su(A)}$ Setup time, A0–A17 (see Note 15)	$t_{AVWH}$	90		50		ns
$t_{su(D)}$ Setup time, DQ	$t_{DVWH}$	90		50		ns
$t_{su(E)}$ Setup time, $\overline{E}$ before write operation	$t_{ELWL}$	0		0		ns
$t_{su(RP)}$ Setup time, $\overline{RP}$ at $V_{HH}$ to $\overline{W}$ going high	$t_{PHHWH}$	200		100		ns
$t_{su(VPP)1}$ Setup time, $V_{PP}$ to $\overline{W}$ going high	$t_{VPWH}$	200		100		ns
$t_w(W)$ Pulse duration, $\overline{W}$ low	$t_{WLWH}$	90		50		ns
$t_w(WH)$ Pulse duration, $\overline{W}$ high	$t_{WHWL}$	20		10		ns
$t_{rec(RPHW)}$ Recovery time, $\overline{RP}$ high to $\overline{W}$ going low	$t_{PHWL}$	800		450		ns

NOTE 15: A<sub>1</sub>–A17 for byte-wide



**TMS28F004Axy, TMS28F400Axy**  
**524288 BY 8-BIT/262144 BY 16-BIT**  
**AUTO-SELECT BOOT-BLOCK FLASH MEMORIES**

SMJS829A – JANUARY 1996 – REVISED AUGUST 1997

**timing requirements for TMS28F004AEy and TMS28F400AEy (continued)**

**write/erase operations —  $\overline{W}$ -controlled writes**

	ALT. SYMBOL	'28F004AEy70 '28F400AEy70				'28F004AEy80 '28F400AEy80				UNIT	
		3.0-V VCC RANGE		5-V VCC RANGE		3.0-V VCC RANGE		5-V VCC RANGE			
		MIN	MAX	MIN	MAX	MIN	MAX	MIN	MAX		
$t_{c(W)}$	Cycle time, write	$t_{AVAV}$	130		70		150		80	ns	
$t_{c(W)OP}$	Cycle time, duration of programming operation	$t_{WHQV1}$	6		6		6		6	$\mu$ s	
$t_{c(W)ERB}$	Cycle time, erase operation (boot block)	$t_{WHQV2}$	0.3		0.3		0.3		0.3	s	
$t_{c(W)ERP}$	Cycle time, erase operation (parameter block)	$t_{WHQV3}$	0.3		0.3		0.3		0.3	s	
$t_{c(W)ERM}$	Cycle time, erase operation (main block)	$t_{WHQV4}$	0.6		0.6		0.6		0.6	s	
$t_{d(RPR)}$	Delay time, boot-block relock	$t_{PHBR}$		200		100		200		100	ns
$t_{h(A)}$	Hold time, A0–A17 (see Note 15)	$t_{WHAX}$	0		0		0		0	ns	
$t_{h(D)}$	Hold time, DQ valid	$t_{WHDX}$	0		0		0		0	ns	
$t_{h(E)}$	Hold time, $\overline{E}$	$t_{WHEH}$	0		0		0		0	ns	
$t_{h(VPP)}$	Hold time, Vpp from valid status register bit	$t_{QVVL}$	0		0		0		0	ns	
$t_{h(RP)}$	Hold time, $\overline{RP}$ at V <sub>HH</sub> from valid status register bit	$t_{QVPH}$	0		0		0		0	ns	
$t_{h(WP)}$	Hold time, $\overline{WP}$ from valid status register bit	$t_{WHPL}$	0		0		0		0	ns	
$t_{su(WP)}$	Setup time, $\overline{WP}$ before write operation	$t_{ELPH}$	105		50		120		50	ns	
$t_{su(A)}$	Setup time, A0–A17 (see Note 15)	$t_{AVWH}$	105		50		120		50	ns	
$t_{su(D)}$	Setup time, DQ	$t_{DVWH}$	105		50		120		50	ns	
$t_{su(E)}$	Setup time, $\overline{E}$ before write operation	$t_{ELWL}$	0		0		0		0	ns	
$t_{su(RP)}$	Setup time, $\overline{RP}$ at V <sub>HH</sub> to $\overline{W}$ going high	$t_{PHHWH}$	200		100		200		100	ns	
$t_{su(VPP)1}$	Setup time, Vpp to $\overline{W}$ going high	$t_{VPWH}$	200		100		200		100	ns	
$t_{w(W)}$	Pulse duration, $\overline{W}$ low	$t_{WLWH}$	105		50		120		50	ns	
$t_{w(WH)}$	Pulse duration, $\overline{W}$ high	$t_{WLWL}$	25		20		30		30	ns	
$t_{rec(RPHW)}$	Recovery time, $\overline{RP}$ high to $\overline{W}$ going low	$t_{PHWL}$	800		450		800		450	ns	

NOTE 15: A<sub>1</sub>–A17 for byte-wide



**TMS28F004Axy, TMS28F400Axy**  
**524288 BY 8-BIT/262144 BY 16-BIT**  
**AUTO-SELECT BOOT-BLOCK FLASH MEMORIES**

SMJS829A – JANUARY 1996 – REVISED AUGUST 1997

**timing requirements for TMS28F004AEy and TMS28F400AEy**

**write/erase operations —  $\bar{E}$ -controlled writes**

	ALT. SYMBOL	'28F004AEy 60 '28F400AEy 60				UNIT
		3-V V <sub>CC</sub> RANGE		5-V V <sub>CC</sub> RANGE		
		MIN	MAX	MIN	MAX	
t <sub>c</sub> (E)      Cycle time, write	t <sub>AVAV</sub>	110		60		ns
t <sub>c</sub> (E)OP    Cycle time, duration of programming operation	t <sub>EHQV1</sub>	6		6		μs
t <sub>c</sub> (E)ERB    Cycle time, erase operation (boot block)	t <sub>EHQV2</sub>	0.3		0.3		s
t <sub>c</sub> (E)ERP    Cycle time, erase operation (parameter block)	t <sub>EHQV3</sub>	0.3		0.3		s
t <sub>c</sub> (E)ERM    Cycle time, erase operation (main block)	t <sub>EHQV4</sub>	0.6		0.6		s
t <sub>d</sub> (RPR)    Delay time, boot-block relock	t <sub>PHBR</sub>		200		100	ns
t <sub>h</sub> (A)      Hold time, A <sub>0</sub> –A <sub>17</sub> (see Note 15)	t <sub>EHAX</sub>	0		0		ns
t <sub>h</sub> (D)      Hold time, DQ valid	t <sub>EHDX</sub>	0		0		ns
t <sub>h</sub> (W)      Hold time, $\bar{W}$	t <sub>EHWH</sub>	0		0		ns
t <sub>h</sub> (VPP)    Hold time, V <sub>PP</sub> from valid status-register bit	t <sub>QVVL</sub>	0		0		ns
t <sub>h</sub> (RP)    Hold time, $\bar{RP}$ at V <sub>HH</sub> from valid status-register bit	t <sub>QVPH</sub>	0		0		ns
t <sub>h</sub> (WP)    Hold time, $\bar{WP}$ from valid status register bit	t <sub>WHPL</sub>	0		0		ns
t <sub>su</sub> (WP)    Setup time, $\bar{WP}$ before write operation	t <sub>ELPH</sub>	90		50		ns
t <sub>su</sub> (A)    Setup time, A <sub>0</sub> –A <sub>17</sub> (see Note 15)	t <sub>AVEH</sub>	90		50		ns
t <sub>su</sub> (D)    Setup time, DQ	t <sub>DVEH</sub>	90		50		ns
t <sub>su</sub> (W)    Setup time, $\bar{W}$ before write operation	t <sub>WLEL</sub>	0		0		ns
t <sub>su</sub> (RP)    Setup time, $\bar{RP}$ at V <sub>HH</sub> to $\bar{E}$ going high	t <sub>PHHEH</sub>	200		100		ns
t <sub>su</sub> (VPP)2    Setup time, V <sub>PP</sub> to $\bar{E}$ going high	t <sub>VPEH</sub>	200		100		ns
t <sub>w</sub> (E)      Pulse duration, $\bar{E}$ low	t <sub>ELEH</sub>	90		50		ns
t <sub>w</sub> (EH)    Pulse duration, $\bar{E}$ high	t <sub>EHEL</sub>	20		10		ns
t <sub>rec</sub> (RPHE)    Recovery time, $\bar{RP}$ high to $\bar{E}$ going low	t <sub>PHL</sub>	800		450		ns

NOTE 15: A<sub>1</sub>–A<sub>17</sub> for byte-wide



**TMS28F004Axy, TMS28F400Axy**  
**524288 BY 8-BIT/262144 BY 16-BIT**  
**AUTO-SELECT BOOT-BLOCK FLASH MEMORIES**

SMJS829A – JANUARY 1996 – REVISED AUGUST 1997

**timing requirements for TMS28F004AEy and TMS28F400AEy (continued)**

**write/erase operations —  $\overline{E}$ -controlled writes**

	ALT. SYMBOL	'28F004AEy70 '28F400AEy70				'28F004AEy80 '28F400AEy80				UNIT	
		3-V $V_{CC}$ RANGE		5-V $V_{CC}$ RANGE		3-V $V_{CC}$ RANGE		5-V $V_{CC}$ RANGE			
		MIN	MAX	MIN	MAX	MIN	MAX	MIN	MAX		
$t_{c(E)}$	Cycle time, write	$t_{AVAV}$	130		70		150		80	ns	
$t_{c(E)OP}$	Cycle time, duration of programming operation	$t_{EHQV1}$	6		6		6		6	$\mu$ s	
$t_{c(E)ERB}$	Cycle time, erase operation (boot block)	$t_{EHQV2}$	0.3		0.3		0.3		0.3	s	
$t_{c(E)ERP}$	Cycle time, erase operation (parameter block)	$t_{EHQV3}$	0.3		0.3		0.3		0.3	s	
$t_{c(E)ERM}$	Cycle time, erase operation (main block)	$t_{EHQV4}$	0.6		0.6		0.6		0.6	s	
$t_d(RPR)$	Delay time, boot-block relock	$t_{PHBR}$		200		100		200		100	ns
$t_h(A)$	Hold time, A0–A17 (see Note 15)	$t_{EHAX}$	0		0		0		0	ns	
$t_h(D)$	Hold time, DQ valid	$t_{EHDX}$	0		0		0		0	ns	
$t_h(W)$	Hold time, $\overline{W}$	$t_{EHWH}$	0		0		0		0	ns	
$t_h(VPP)$	Hold time, $V_{PP}$ from valid status-register bit	$t_{QVVL}$	0		0		0		0	ns	
$t_h(RP)$	Hold time, $\overline{RP}$ at $V_{HH}$ from valid status-register bit	$t_{QVPH}$	0		0		0		0	ns	
$t_h(WP)$	Hold time, $\overline{WP}$ from valid status register bit	$t_{WHPL}$	0		0		0		0	ns	
$t_{su}(WP)$	Setup time, $\overline{WP}$ before write operation	$t_{ELPH}$	105		50		120		50	ns	
$t_{su}(A)$	Setup time, A0–A17 (see Note 15)	$t_{AVEH}$	105		50		120		50	ns	
$t_{su}(D)$	Setup time, DQ	$t_{DVEH}$	105		50		120		50	ns	
$t_{su}(W)$	Setup time, $\overline{W}$ before write operation	$t_{WLEL}$	0		0		0		0	ns	
$t_{su}(RP)$	Setup time, $\overline{RP}$ at $V_{HH}$ to $\overline{E}$ going high	$t_{PHHEH}$	200		100		200		100	ns	
$t_{su}(VPP)2$	Setup time, $V_{PP}$ to $\overline{E}$ going high	$t_{VPEH}$	200		100		200		100	ns	
$t_w(E)$	Pulse duration, $\overline{E}$ low	$t_{ELEH}$	105		50		120		50	ns	
$t_w(EH)$	Pulse duration, $\overline{E}$ high	$t_{EHEL}$	25		20		30		30	ns	
$t_{rec}(RPHE)$	Recovery time, $\overline{RP}$ high to $\overline{E}$ going low	$t_{PHEL}$	800		450		800		450	ns	

NOTE 15: A<sub>1</sub>–A17 for byte-wide



**TMS28F004Axy, TMS28F400Axy**  
**524288 BY 8-BIT/262144 BY 16-BIT**  
**AUTO-SELECT BOOT-BLOCK FLASH MEMORIES**

SMJS829A – JANUARY 1996 – REVISED AUGUST 1997

**TMS28F004AMy and TMS28F400AMy**

The TMS28F004AMy and the TMS28F400AMy configurations offer a 3-V or 5-V memory read with a 12-V program and erase. This configuration is intended for low 3.3-V reads and the fast programming offered with the 12-V  $V_{PP} = 12\text{ V}$  and 5-V  $V_{CC}$ . This configuration is offered in two different temperature ranges: 0°C to 70°C and – 40°C to 85°C.

**recommended operating conditions for TMS28F004AMy and TMS28F400AMy**

			MIN	NOM	MAX	UNIT	
$V_{CC}$	Supply voltage	During write/read/erase/erase suspend	3.3-V $V_{CC}$ range			V	
			3	3.3	3.6		
$V_{PP}$	Supply voltage	During read only ( $V_{PPL}$ )	$V_{PPL}$			V	
		During write/erase/erase suspend	12-V $V_{PP}$ range				
$V_{IH}$	High-level dc input voltage	3.3 V $V_{CC}$ range	TTL		$V_{CC} + 0.5$	V	
			CMOS		$V_{CC} - 0.2$		$V_{CC} + 0.2$
		5 V $V_{CC}$ range	TTL		2		$V_{CC} + 0.3$
			CMOS		$V_{CC} - 0.2$		$V_{CC} + 0.2$
$V_{IL}$	Low-level dc input voltage	3.3 V $V_{CC}$ range	TTL		– 0.5	V	
			CMOS		$V_{SS} - 0.2$		$V_{SS} + 0.2$
		5 V $V_{CC}$ range	TTL		– 0.3		0.8
			CMOS		$V_{SS} - 0.2$		$V_{SS} + 0.2$
$V_{LKO}$	$V_{CC}$ lock-out voltage from write/erase (see Note 7)		2			V	
$V_{HH}$	$\overline{RP}$ unlock voltage		11.4	12	13	V	
$V_{PPLK}$	$V_{PP}$ lock-out voltage from write/erase		0			V	
$T_A$	Operating free-air temperature	L Suffix	0			°C	
		E Suffix	– 40				

NOTE 7: Minimum value at  $T_A = 25^\circ\text{C}$ .

**word/byte typical write and block-erase performance for TMS28F004AMy and TMS28F400AMy (see Notes 8 and 9)**

PARAMETER	12-V $V_{PP}$ RANGE					
	3.3-V $V_{CC}$ RANGE			5-V $V_{CC}$ RANGE		
	MIN	TYP	MAX	MIN	TYP	MAX
Main block-erase time	1.3			1.1 14		
Main block-byte program time	1.6			1.2 4.2		
Main block-word program time	0.8			0.6 2.1		
Parameter/boot-block erase time	0.44			0.34 7		

NOTES: 8. Typical values shown are at  $T_A = 25^\circ\text{C}$  and nominal conditions.

9. Excludes system-level overhead (all times in seconds)



**TMS28F004Axy, TMS28F400Axy**  
**524288 BY 8-BIT/262144 BY 16-BIT**  
**AUTO-SELECT BOOT-BLOCK FLASH MEMORIES**

SMJS829A – JANUARY 1996 – REVISED AUGUST 1997

**electrical characteristics for TMS28F004AMy and TMS28F400AMy over recommended ranges of supply voltage and operating free-air temperature using test conditions given in Table 9 (unless otherwise noted)**

PARAMETER		TEST CONDITIONS		MIN	MAX	UNIT	
V <sub>OH</sub>	High-level dc output voltage	TTL	V <sub>CC</sub> = V <sub>CC</sub> MIN, I <sub>OH</sub> = - 2.5 mA	2.4		V	
		CMOS	V <sub>CC</sub> = V <sub>CC</sub> MIN, I <sub>OH</sub> = - 100 μA	V <sub>CC</sub> - 0.4			
V <sub>OL</sub>	Low-level dc output voltage		V <sub>CC</sub> = V <sub>CC</sub> MIN, I <sub>OL</sub> = 5.8 mA		0.45	V	
V <sub>ID</sub>	A9 selection code voltage		During read algorithm-selection mode	11.4	12.6	V	
I <sub>I</sub>	Input current (leakage), except for A9 when A9 = V <sub>ID</sub> (see Note 10)		V <sub>CC</sub> = V <sub>CC</sub> MAX, V <sub>I</sub> = 0 V to V <sub>CC</sub> MAX, $\overline{RP} = V_{HH}$		±1	μA	
I <sub>ID</sub>	A9 selection code current		A9 = V <sub>ID</sub>		500	μA	
I <sub>RP</sub>	$\overline{RP}$ boot-block unlock current		$\overline{RP} = V_{HH}$		500	μA	
I <sub>O</sub>	Output current (leakage)		V <sub>CC</sub> = V <sub>CC</sub> MAX, V <sub>O</sub> = 0 V to V <sub>CC</sub> MAX		±10	μA	
I <sub>PPS</sub>	V <sub>PP</sub> standby current (standby)	V <sub>PP</sub> ≤ V <sub>CC</sub>	3.3-V V <sub>CC</sub> range		15	μA	
			5-V V <sub>CC</sub> range		10		
I <sub>PPL</sub>	V <sub>PP</sub> supply current (reset/deep power-down mode)	$\overline{RP} = V_{SS} \pm 0.2$ V, V <sub>PP</sub> ≤ V <sub>CC</sub>	3.3-V V <sub>CC</sub> range		5	μA	
			5-V V <sub>CC</sub> range		5		
I <sub>PP1</sub>	V <sub>PP</sub> supply current (active read)	V <sub>PP</sub> ≥ V <sub>CC</sub>	3.3-V V <sub>CC</sub> range		200	μA	
			5-V V <sub>CC</sub> range		200		
I <sub>PP2</sub>	V <sub>PP</sub> supply current (active byte-write) (see Notes 11 and 12)	Programming in progress	12-V V <sub>PP</sub> range, 3.3-V V <sub>CC</sub> range		25	mA	
			12-V V <sub>PP</sub> range, 5-V V <sub>CC</sub> range		20		
I <sub>PP3</sub>	V <sub>PP</sub> supply current (active word-write) (see Notes 11 and 12)	Programming in progress	12-V V <sub>PP</sub> range, 3.3-V V <sub>CC</sub> range		25	mA	
			12-V V <sub>PP</sub> range, 5-V V <sub>CC</sub> range		20		
I <sub>PP4</sub>	V <sub>PP</sub> supply current (block-erase) (see Notes 11 and 12)	Block-erase in progress	12-V V <sub>PP</sub> range, 3.3-V V <sub>CC</sub> range		25	mA	
			12-V V <sub>PP</sub> range, 5-V V <sub>CC</sub> range		15		
I <sub>PP5</sub>	V <sub>PP</sub> supply current (erase-suspend) (see Notes 11 and 12)	Block-erase suspended	12-V V <sub>PP</sub> range, 3.3-V V <sub>CC</sub> range		200	μA	
			12-V V <sub>PP</sub> range, 5-V V <sub>CC</sub> range		200		
I <sub>CCS</sub>	V <sub>CC</sub> supply current (standby)	TTL-input level	V <sub>CC</sub> = V <sub>CC</sub> MAX, E = RP = V <sub>IH</sub>	3.3-V V <sub>CC</sub> range	1.5	mA	
			5-V V <sub>CC</sub> range		2		
		CMOS-input level	V <sub>CC</sub> = V <sub>C</sub> CMAX, E = RP = V <sub>CC</sub> ± 0.2 V	3.3-V V <sub>CC</sub> range		110	μA
			5-V V <sub>CC</sub> range		130		
I <sub>CCL</sub>	V <sub>CC</sub> supply current (reset/deep power-down mode)	$\overline{RP} = V_{SS} \pm 0.2$ V; V <sub>CC</sub> = V <sub>CC</sub> MAX	0°C to 70°C		8	μA	
			- 40°C to 85°C		8		

- NOTES: 10. DQ15/A<sub>1</sub> is tested for output leakage only.  
11. Characterization data available  
12. All ac current values are RMS unless otherwise noted.



**TMS28F004Axy, TMS28F400Axy**  
**524288 BY 8-BIT/262144 BY 16-BIT**  
**AUTO-SELECT BOOT-BLOCK FLASH MEMORIES**

SMJS829A – JANUARY 1996 – REVISED AUGUST 1997

electrical characteristics for TMS28F004AMy and TMS28F400AMy over recommended ranges of supply voltage and operating free-air temperature using test conditions given in Table 9 (unless otherwise noted) (continued)

PARAMETER		TEST CONDITIONS		MIN	MAX	UNIT
I <sub>CC1</sub>	V <sub>CC</sub> supply current (active read)	TTL-input level	$\bar{E} = V_{IL}, I_{OUT} = 0 \text{ mA}, f = 5 \text{ MHz}, G = V_{IH}$	3.3-V V <sub>CC</sub> range	30	mA
			$\bar{E} = V_{IL}, I_{OUT} = 0 \text{ mA}, f = 10 \text{ MHz}, G = V_{IH}$	5-V V <sub>CC</sub> range	65	
	CMOS-input level		$\bar{E} = V_{IL}, I_{OUT} = 0 \text{ mA}, f = 5 \text{ MHz}, G = V_{CC}$	3.3-V V <sub>CC</sub> range	30	mA
			$\bar{E} = V_{IL}, I_{OUT} = 0 \text{ mA}, f = 10 \text{ MHz}, G = V_{CC}$	5-V V <sub>CC</sub> range	60	
I <sub>CC2</sub>	V <sub>CC</sub> supply current (active byte-write) (see Notes 11 and 12)	V <sub>CC</sub> = V <sub>CC</sub> MAX, Programming in progress	12-V V <sub>PP</sub> range, 3.3-V V <sub>CC</sub> range		25	mA
			12-V V <sub>PP</sub> range, 5-V V <sub>CC</sub> range		45	
I <sub>CC3</sub>	V <sub>CC</sub> supply current (active word-write) (see Notes 11 and 12)	V <sub>CC</sub> = V <sub>CC</sub> MAX, Programming in progress	12-V V <sub>PP</sub> range, 3.3-V V <sub>CC</sub> range		25	mA
			12-V V <sub>PP</sub> range, 5-V V <sub>CC</sub> range		45	
I <sub>CC4</sub>	V <sub>CC</sub> supply current (block-erase) (see Notes 11 and 12)	V <sub>CC</sub> = V <sub>CC</sub> MAX, Block-erase in progress	12-V V <sub>PP</sub> range, 3.3-V V <sub>CC</sub> range		25	mA
			12-V V <sub>PP</sub> range, 5-V V <sub>CC</sub> range		30	
I <sub>CC5</sub>	V <sub>CC</sub> supply current (erase-suspend) (see Notes 11 and 12)	V <sub>CC</sub> = V <sub>CC</sub> MAX, $\bar{E} = V_{IH}$ , Block-erase suspended	3.3-V V <sub>CC</sub> range		8	mA
			5-V V <sub>CC</sub> range		10	

NOTES: 11. Characterization data available  
12. All ac current values are RMS unless otherwise noted.



power-up and reset switching characteristics for TMS28F004Axy and TMS28F400Axy over recommended ranges of supply voltage (commercial and extended temperature ranges)(see Notes 11, 12, and 13)

PARAMETER	ALT. SYMBOL	'28F004Axy60 '28F400Axy60				'28F004Axy70 '28F400Axy70				'28F004Axy80 '28F400Axy80				UNIT
		3.3-V VCC RANGE		5-V VCC RANGE		3.3-V VCC RANGE		5-V VCC RANGE		3.3-V VCC RANGE		5-V VCC RANGE		
		MIN	MAX	MIN	MAX	MIN	MAX	MIN	MAX	MIN	MAX	MIN	MAX	
Setup time, $\overline{RP}$ low to $V_{CC}$ at 4.5 V MIN (to $V_{CC}$ at 3 V MIN or 3.6 V MAX) (see Note 14)	t <sub>PL5V</sub> t <sub>PL3V</sub>	0		0		0		0		0		0		ns
t <sub>a</sub> (DV) Address valid to data valid	t <sub>AVQV</sub>		110		60		130		70		150		80	ns
t <sub>su</sub> (DV) Setup time, $\overline{RP}$ high to data valid	t <sub>PHQV</sub>		800		450		800		450		800		450	ns
t <sub>h</sub> (RP5) Hold time, $V_{CC}$ at 4.5 V (MIN) to $\overline{RP}$ high	t <sub>5VPH</sub>	2		2		2		2		2		2		μs
t <sub>h</sub> (RP3) Hold time, $V_{CC}$ at 3 V (MIN) to $\overline{RP}$ high	t <sub>3VPH</sub>	2		2		2		2		2		2		μs

- NOTES: 11. Characterization data available  
 12. All ac current values are RMS unless otherwise noted.  
 13. E and G are switched low after power up.  
 14. The power supply can switch low concurrently with  $\overline{RP}$  going low.

**TMS28F004Axy, TMS28F400Axy**  
**524288 BY 8-BIT/262144 BY 16-BIT**  
**AUTO-SELECT BOOT-BLOCK FLASH MEMORIES**

SMJS829A – JANUARY 1996 – REVISED AUGUST 1997

switching characteristics for TMS28F004AMy and TMS28F400AMy over recommended ranges of supply voltage (commercial and extended temperature ranges)

read operations

PARAMETER	ALT. SYMBOL	'28F004AMy60 '28F400AMy60				'28F004AMy70 '28F400AMy70				'28F004AMy80 '28F400AMy80				UNIT
		3.3-V VCC RANGE		5-V VCC RANGE		3.3-V VCC RANGE		5-V VCC RANGE		3.3-V VCC RANGE		5-V VCC RANGE		
		MIN	MAX	MIN	MAX	MIN	MAX	MIN	MAX	MIN	MAX	MIN	MAX	
t <sub>a</sub> (A) Access time from A0 – A17 (see Note 15)	t <sub>AVQV</sub>	110	60	130	70	150	80	150	80	150	80	ns		
t <sub>a</sub> (E) Access time from $\bar{E}$	t <sub>ELQV</sub>	110	60	130	70	150	80	150	80	150	80	ns		
t <sub>a</sub> (G) Access time from $\bar{G}$	t <sub>GLQV</sub>	65	35	80	40	90	40	90	40	90	40	ns		
t <sub>c</sub> (R) Cycle time, read	t <sub>AVAV</sub>	110	60	130	70	150	80	150	80	150	80	ns		
t <sub>d</sub> (E) Delay time, $\bar{E}$ low to low-impedance output	t <sub>ELQX</sub>	0	0	0	0	0	0	0	0	0	0	ns		
t <sub>d</sub> (G) Delay time, $\bar{G}$ low to low-impedance output	t <sub>GLQX</sub>	0	0	0	0	0	0	0	0	0	0	ns		
t <sub>dis</sub> (E) Disable time, $\bar{E}$ to high-impedance output	t <sub>EHQZ</sub>	55	25	70	30	80	30	80	30	80	30	ns		
t <sub>dis</sub> (G) Disable time, $\bar{G}$ to high-impedance output	t <sub>GHQZ</sub>	45	25	55	30	60	30	60	30	60	30	ns		
t <sub>h</sub> (D) Hold time, DQ valid from A0 – A17, $\bar{E}$ , or $\bar{G}$ , whichever occurs first (see Note 15)	t <sub>AXQX</sub>	0	0	0	0	0	0	0	0	0	0	ns		
t <sub>su</sub> (EB) Setup time, $\overline{\text{BYTE}}$ from $\bar{E}$ low	t <sub>ELFL</sub> t <sub>ELFH</sub>	5	5	5	5	5	5	5	5	5	5	ns		
t <sub>d</sub> (RP) Output delay time from $\overline{\text{RP}}$ high	t <sub>PHQV</sub>	800	450	800	450	800	450	800	450	800	450	ns		
t <sub>dis</sub> (BL) Disable time, $\overline{\text{BYTE}}$ low to DQ8 – DQ15 in high-impedance state	t <sub>FLQZ</sub>	45	25	55	30	60	30	60	30	60	30	ns		
t <sub>a</sub> (BH) Access time from $\overline{\text{BYTE}}$ going high	t <sub>FHQV</sub>	110	60	130	70	150	80	150	80	150	80	ns		

NOTE 15: A<sub>1</sub> – A<sub>17</sub> for byte-wide



timing requirements for TMS28F004AMy and TMS28F400AMy

write/erase operations —  $\bar{W}$ -controlled writes

	ALT. SYMBOL	'28F004AMy60 '28F400AMy60				'28F004AMy70 '28F400AMy70				'28F004AMy80 '28F400AMy80				UNIT
		3.3-V VCC RANGE		5-V VCC RANGE		3.3-V VCC RANGE		5-V VCC RANGE		3.3-V VCC RANGE		5-V VCC RANGE		
		MIN	MAX	MIN	MAX	MIN	MAX	MIN	MAX	MIN	MAX	MIN	MAX	
$t_c(W)$	Cycle time, write	110		60		130		70		150		80		ns
$t_c(W)_{OP}$	Cycle time, duration of programming operation	6		6		6		6		6		6		$\mu$ s
$t_c(W)_{ERB}$	Cycle time, erase operation (boot block)	0.3		0.3		0.3		0.3		0.3		0.3		s
$t_c(W)_{ERP}$	Cycle time, erase operation (parameter block)	0.3		0.3		0.3		0.3		0.3		0.3		s
$t_c(W)_{ERM}$	Cycle time, erase operation (main block)	0.6		0.6		0.6		0.6		0.6		0.6		s
$t_d(RPR)$	Delay time, boot-block reload		200		100		200		100		200		100	ns
$t_h(A)$	Hold time, A0–A17 (see Note 15)	0		0		0		0		0		0		ns
$t_h(D)$	Hold time, DQ valid	0		0		0		0		0		0		ns
$t_h(E)$	Hold time, $\bar{E}$	0		0		0		0		0		0		ns
$t_h(VPP)$	Hold time, Vpp from valid status register bit	0		0		0		0		0		0		ns
$t_h(RP)$	Hold time, $\bar{RP}$ at V <sub>HH</sub> from valid status register bit	0		0		0		0		0		0		ns
$t_{su}(A)$	Setup time, A0–A17 (see Note 15)	90		50		105		50		120		50		ns
$t_{su}(D)$	Setup time, DQ	90		50		105		50		120		50		ns
$t_{su}(E)$	Setup time, $\bar{E}$ before write operation	0		0		0		0		0		0		ns

NOTE 15: A<sub>n-1</sub>–A17 for byte-wide

**TMS28F004Axy, TMS28F400Axy**  
**524288 BY 8-BIT/262144 BY 16-BIT**  
**AUTO-SELECT BOOT-BLOCK FLASH MEMORIES**  
 SMJS829A – JANUARY 1996 – REVISED AUGUST 1997

**timing requirements for TMS28F004AMy and TMS28F400AMy (continued)**  
**write/erase operations —  $\bar{W}$ -controlled writes**

	ALT. SYMBOL	'28F004AMy60 '28F400AMy60				'28F004AMy70 '28F400AMy70				'28F004AMy80 '28F400AMy80				UNIT
		3.3-V V <sub>CC</sub> RANGE		5-V V <sub>CC</sub> RANGE		3.3-V V <sub>CC</sub> RANGE		5-V V <sub>CC</sub> RANGE		3.3-V V <sub>CC</sub> RANGE		5-V V <sub>CC</sub> RANGE		
		MIN	MAX	MIN	MAX	MIN	MAX	MIN	MAX	MIN	MAX	MIN	MAX	
t <sub>su</sub> (RP)	Setup time, $\overline{RP}$ at V <sub>HH</sub> to $\bar{W}$ going high	200		100		200		100		200		100		ns
t <sub>su</sub> (VPP)1	Setup time, V <sub>pp</sub> to $\bar{W}$ going high	200		100		200		100		200		100		ns
t <sub>w</sub> (W)	Pulse duration, $\bar{W}$ low	90		50		105		50		120		50		ns
t <sub>w</sub> (WH)	Pulse duration, $\bar{W}$ high	20		10		25		20		30		30		ns
t <sub>rec</sub> (RPHW)	Recovery time, $\overline{RP}$ high to $\bar{W}$ going low	800		450		800		450		800		450		ns

NOTE 15: A<sub>-1</sub> – A<sub>17</sub> for byte-wide

timing requirements for TMS28F004AMy and TMS28F400AMy

write/erase operations —  $\bar{E}$ -controlled writes

	ALT. SYMBOL	'28F004AMy60 '28F400AMy60				'28F004AMy70 '28F400AMy70				'28F004AMy80 '28F400AMy80				UNIT
		3.3-V VCC RANGE		5-V VCC RANGE		3.3-V VCC RANGE		5-V VCC RANGE		3.3-V VCC RANGE		5-V VCC RANGE		
		MIN	MAX	MIN	MAX	MIN	MAX	MIN	MAX	MIN	MAX	MIN	MAX	
$t_c(E)$	Cycle time, write	110		60		130		70		150		80		ns
$t_c(E)OP$	Cycle time, duration of programming operation	6		6		6		6		6		6		$\mu$ s
$t_c(E)ERB$	Cycle time, erase operation (boot block)	0.3		0.3		0.3		0.3		0.3		0.3		s
$t_c(E)ERP$	Cycle time, erase operation (parameter block)	0.3		0.3		0.3		0.3		0.3		0.3		s
$t_c(E)ERM$	Cycle time, erase operation (main block)	0.6		0.6		0.6		0.6		0.6		0.6		s
$t_d(RPR)$	Delay time, boot-block reload		200		100		200		100		200		100	ns
$t_h(A)$	Hold time, A0–A17 (see Note 15)	0		0		0		0		0		0		ns
$t_h(D)$	Hold time, DQ valid	0		0		0		0		0		0		ns
$t_h(W)$	Hold time, $\bar{W}$	0		0		0		0		0		0		ns
$t_h(VPP)$	Hold time, Vpp from valid status-register bit	0		0		0		0		0		0		ns
$t_h(RP)$	Hold time, $\bar{RP}$ at VHH from valid status-register bit	0		0		0		0		0		0		ns
$t_{su}(A)$	Setup time, A0–A17 (see Note 15)	90		50		105		50		120		50		ns
$t_{su}(D)$	Setup time, DQ	90		50		105		50		120		50		ns
$t_{su}(W)$	Setup time, $\bar{W}$ before write operation	0		0		0		0		0		0		ns
$t_{su}(RP)$	Setup time, $\bar{RP}$ at VHH to $\bar{E}$ going high	200		100		200		100		200		100		ns
$t_{su}(VPP)2$	Setup time, Vpp to $\bar{E}$ going high	200		100		200		100		200		100		ns
$t_{wr}(E)$	Pulse duration, $\bar{E}$ low	90		50		105		50		120		50		ns
$t_{wr}(EH)$	Pulse duration, $\bar{E}$ high	20		10		25		20		30		30		ns
$t_{rec}(RPHE)$	Recovery time, $\bar{RP}$ high to $\bar{E}$ going low	800		450		800		450		800		450		ns

NOTE 15: A<sub>-1</sub> – A17 for byte-wide

**TMS28F004Axy, TMS28F400Axy**  
**524288 BY 8-BIT/262144 BY 16-BIT**  
**AUTO-SELECT BOOT-BLOCK FLASH MEMORIES**

SMJS829A – JANUARY 1996 – REVISED AUGUST 1997

**TMS28F004AFy and TMS28F400AFy**

The TMS28F004AFy and the TMS28F400AFy configurations offer a 5-V memory read with a 5-V or 12-V program and erase. This configuration is intended for systems using a single 5-V power supply and it is offered in three temperature ranges: 0°C to 70°C, – 40°C to 85°C, and – 40°C to 125°C.

**recommended operating conditions for TMS28F004AFy and TMS28F400AFy**

				MIN	NOM	MAX	UNIT
V <sub>CC</sub>	Supply voltage	During write/read/erase/erase suspend	5-V V <sub>CC</sub> range	4.5	5	5.5	V
V <sub>PP</sub>	Supply voltage	During read only (V <sub>PPL</sub> )	V <sub>PPL</sub>	0		6.5	V
		During write/erase/erase suspend	5-V V <sub>PP</sub> range	4.5	5	5.5	
			12-V V <sub>PP</sub> range	11.4	12	12.6	
V <sub>IH</sub>	High-level dc input voltage	TTL		2		V <sub>CC</sub> + 0.3	V
		CMOS		V <sub>CC</sub> – 0.2		V <sub>CC</sub> + 0.2	
V <sub>IL</sub>	Low-level dc input voltage	TTL		– 0.3		0.8	V
		CMOS		V <sub>SS</sub> – 0.2		V <sub>SS</sub> + 0.2	
V <sub>LKO</sub>	V <sub>CC</sub> lock-out voltage from write/erase (see Note 7)			2			V
V <sub>HH</sub>	RP unlock voltage			11.4	12	13	V
V <sub>PPLK</sub>	V <sub>PP</sub> lock-out voltage from write/erase			0		1.5	V
T <sub>A</sub>	Operating free-air temperature	L Suffix		0		70	°C
		E Suffix		– 40		85	
		Q Suffix		– 40		125	

NOTE 7: Minimum value at T<sub>A</sub> = 25°C.

**word/byte typical write and block-erase performance for TMS28F004AFy and TMS28F400AFy (see Notes 8 and 9)**

PARAMETER	5-V V <sub>PP</sub> AND 5-V V <sub>CC</sub> RANGES			12-V V <sub>PP</sub> AND 5-V V <sub>CC</sub> RANGES		
	MIN	TYP	MAX	MIN	TYP	MAX
Main block erase time		1.9			1.1	14
Main block byte-program time		1.4			1.2	4.2
Main block word-program time		0.9			0.6	2.1
Parameter/boot-block erase time		0.8			0.34	7

NOTES: 8. Typical values shown are at T<sub>A</sub> = 25°C and nominal conditions.

9. Excludes system-level overhead (all times in seconds)



**TMS28F004Axy, TMS28F400Axy**  
**524288 BY 8-BIT/262144 BY 16-BIT**  
**AUTO-SELECT BOOT-BLOCK FLASH MEMORIES**

SMJS829A – JANUARY 1996 – REVISED AUGUST 1997

electrical characteristics for TMS28F004AFy and TMS28F400AFy over recommended ranges of supply voltage and operating free-air temperature using test conditions given in Table 9 (unless otherwise noted)

PARAMETER		TEST CONDITIONS		MIN	MAX	UNIT
V <sub>OH</sub>	High-level dc output voltage	TTL	V <sub>CC</sub> = V <sub>CC</sub> MIN, I <sub>OH</sub> = - 2.5 mA	2.4		V
		CMOS	V <sub>CC</sub> = V <sub>CC</sub> MIN, I <sub>OH</sub> = - 100 μA	V <sub>CC</sub> - 0.4		
V <sub>OL</sub>	Low-level dc output voltage		V <sub>CC</sub> = V <sub>CC</sub> MIN, I <sub>OL</sub> = 5.8 mA		0.45	V
V <sub>ID</sub>	A9 selection code voltage		During read algorithm-selection mode	11.4	12.6	V
I <sub>I</sub>	Input current (leakage), except for A9 when A9 = V <sub>ID</sub> (see Note 10)		V <sub>CC</sub> = V <sub>CC</sub> MAX, V <sub>I</sub> = 0 V to V <sub>CC</sub> MAX, $\overline{RP} = V_{HH}$		±1	μA
I <sub>ID</sub>	A9 selection code current		A9 = V <sub>ID</sub>		500	μA
I <sub>RP</sub>	$\overline{RP}$ boot-block unlock current		$\overline{RP} = V_{HH}$		500	μA
I <sub>O</sub>	Output current (leakage)		V <sub>CC</sub> = V <sub>CC</sub> MAX, V <sub>O</sub> = 0 V to V <sub>CC</sub> MAX		±10	μA
I <sub>PPS</sub>	V <sub>PP</sub> standby current (standby)		V <sub>PP</sub> ≤ V <sub>CC</sub>	5-V V <sub>CC</sub> range	10	μA
I <sub>PPL</sub>	V <sub>PP</sub> supply current (reset/deep power-down mode)		$\overline{RP} = V_{SS} \pm 0.2$ V, V <sub>PP</sub> ≤ V <sub>CC</sub>	5-V V <sub>CC</sub> range	5	μA
I <sub>PP1</sub>	V <sub>PP</sub> supply current (active read)		V <sub>PP</sub> ≥ V <sub>CC</sub>	5-V V <sub>CC</sub> range	200	μA
I <sub>PP2</sub>	V <sub>PP</sub> supply current (active byte-write) (see Notes 11 and 12)		Programming in progress	5-V V <sub>PP</sub> range, 5-V V <sub>CC</sub> range	25	mA
				12-V V <sub>PP</sub> range, 5-V V <sub>CC</sub> range	20	
I <sub>PP3</sub>	V <sub>PP</sub> supply current (active word-write) (see Notes 11 and 12)		Programming in progress	5-V V <sub>PP</sub> range, 5-V V <sub>CC</sub> range	25	mA
				12-V V <sub>PP</sub> range, 5-V V <sub>CC</sub> range	20	
I <sub>PP4</sub>	V <sub>PP</sub> supply current (block-erase) (see Notes 11 and 12)		Block-erase in progress	5-V V <sub>PP</sub> range, 5-V V <sub>CC</sub> range	20	mA
				12-V V <sub>PP</sub> range, 5-V V <sub>CC</sub> range	15	
I <sub>PP5</sub>	V <sub>PP</sub> supply current (erase-suspend) (see Notes 11 and 12)		Block-erase suspended	5-V V <sub>PP</sub> range, 5-V V <sub>CC</sub> range	200	μA
				12-V V <sub>PP</sub> range, 5-V V <sub>CC</sub> range	200	
I <sub>CCS</sub>	V <sub>CC</sub> supply current (standby)	TTL-input level	V <sub>CC</sub> = V <sub>CC</sub> MAX, $\overline{E} = \overline{RP} = V_{IH}$	5-V V <sub>CC</sub> range	2	mA
		CMOS-input level		5-V V <sub>CC</sub> range	130	
I <sub>CCL</sub>	V <sub>CC</sub> supply current (reset/deep power-down mode)		$\overline{RP} = V_{SS} \pm 0.2$ V	0°C to 70°C	8	μA
				- 40°C to 85°C	8	
				- 40°C to 125°C	40	
I <sub>CC1</sub>	V <sub>CC</sub> supply current (active read)	TTL-input level	$\overline{E} = V_{IL}$ , I <sub>OUT</sub> = 0 mA, f = 10 MHz, $\overline{G} = V_{IH}$	5-V V <sub>CC</sub> range	65	mA
		CMOS-input level	$\overline{E} = V_{SS}$ , I <sub>OUT</sub> = 0 mA, f = 10 MHz, $\overline{G} = V_{CC}$	5-V V <sub>CC</sub> range	60	

- NOTES: 10. DQ15/A<sub>1</sub> is tested for output leakage only.  
11. Characterization data available  
12. All ac current values are RMS unless otherwise noted.



**TMS28F004Axy, TMS28F400Axy**  
**524288 BY 8-BIT/262144 BY 16-BIT**  
**AUTO-SELECT BOOT-BLOCK FLASH MEMORIES**

SMJS829A – JANUARY 1996 – REVISED AUGUST 1997

electrical characteristics for TMS28F004AFy and TMS28F400AFy over recommended ranges of supply voltage and operating free-air temperature using test conditions given in Table 9 (unless otherwise noted) (continued)

PARAMETER		TEST CONDITIONS		MIN	MAX	UNIT
I <sub>CC2</sub>	V <sub>CC</sub> supply current (active byte-write) (see Notes 11 and 12)	V <sub>CC</sub> = V <sub>CC</sub> MAX, Programming in progress	5-V V <sub>PP</sub> range, 5-V V <sub>CC</sub> range		50	mA
			12-V V <sub>PP</sub> range, 5-V V <sub>CC</sub> range		45	
I <sub>CC3</sub>	V <sub>CC</sub> supply current (active word-write) (see Notes 11 and 12)	V <sub>CC</sub> = V <sub>CC</sub> MAX, Programming in progress	5-V V <sub>PP</sub> range, 5-V V <sub>CC</sub> range		50	mA
			12-V V <sub>PP</sub> range, 5-V V <sub>CC</sub> range		45	
I <sub>CC4</sub>	V <sub>CC</sub> supply current (block-erase) (see Notes 11 and 12)	V <sub>CC</sub> = V <sub>CC</sub> MAX V <sub>PP</sub> = 12 V or 5 V Block-erase in progress	5-V V <sub>PP</sub> range, 5-V V <sub>CC</sub> range		35	mA
			12-V V <sub>PP</sub> range, 5-V V <sub>CC</sub> range		30	
I <sub>CC5</sub>	V <sub>CC</sub> supply current (erase-suspend) (see Notes 11 and 12)	V <sub>CC</sub> = V <sub>CC</sub> MAX, $\bar{E} = V_{IH}$ , Block-erase suspended	5-V V <sub>CC</sub> range		10	mA

NOTES: 11. Characterization data available  
12. All ac current values are RMS unless otherwise noted.



**TMS28F004Axy, TMS28F400Axy**  
**524288 BY 8-BIT/262144 BY 16-BIT**  
**AUTO-SELECT BOOT-BLOCK FLASH MEMORIES**

SMJS829A – JANUARY 1996 – REVISED AUGUST 1997

**power-up and reset switching characteristics for TMS28F004AFy and TMS28F400AFy over recommended ranges of supply voltage (commercial and extended temperature ranges) (see Notes 11, 12, and 13)**

PARAMETER	ALT. SYMBOL	'28F004AFy 60 '28F400AFy 60	'28F004AFy 70 '28F400AFy 70	'28F004AFy 80 '28F400AFy 80	UNIT			
		5-V V <sub>CC</sub> RANGE		5-V V <sub>CC</sub> RANGE		5-V V <sub>CC</sub> RANGE		
		MIN	MAX	MIN		MAX	MIN	MAX
t <sub>su</sub> (VCC) Setup time, $\overline{RP}$ low to V <sub>CC</sub> at 4.5 V MIN (see Note 14)	t <sub>PL5V</sub> t <sub>PL3V</sub>	0	0	0	ns			
t <sub>a</sub> (DV) Address valid to data valid	t <sub>AVQV</sub>	60	70	80	ns			
t <sub>su</sub> (DV) Setup time, $\overline{RP}$ high to data valid	t <sub>PHQV</sub>	450	450	450	ns			
t <sub>h</sub> (RP5) Hold time, V <sub>CC</sub> at 4.5 V (MIN) to $\overline{RP}$ high	t <sub>5VPH</sub>	2	2	2	μs			

- NOTES: 11. Characterization data available  
12. All ac current values are RMS unless otherwise noted.  
13.  $\overline{E}$  and  $\overline{G}$  are switched low after power up.  
14. The power supply can switch low concurrently with  $\overline{RP}$  going low.

**power-up and reset switching characteristics for TMS28F400AFy over recommended ranges of supply voltage (automotive temperature range) (see Notes 11, 12, 13)**

PARAMETER	ALT. SYMBOL	'28F004AFy 70 '28F400AFy 70	'28F004AFy 80 '28F400AFy 80	'28F004AFy 90 '28F400AFy 90	UNIT			
		5-V V <sub>CC</sub> RANGE		5-V V <sub>CC</sub> RANGE		5-V V <sub>CC</sub> RANGE		
		MIN	MAX	MIN		MAX	MIN	MAX
t <sub>su</sub> (VCC) Setup time, $\overline{RP}$ low to V <sub>CC</sub> at 4.5 V MIN (see Note 14)	t <sub>PL5V</sub> t <sub>PL3V</sub>	0	0	0	ns			
t <sub>a</sub> (DV) Address valid to data valid	t <sub>AVQV</sub>	70	80	90	ns			
t <sub>su</sub> (DV) Setup time, $\overline{RP}$ high to data valid	t <sub>PHQV</sub>	450	450	450	ns			
t <sub>h</sub> (RP5) Hold time, V <sub>CC</sub> at 4.5 V (MIN) to $\overline{RP}$ high	t <sub>5VPH</sub>	2	2	2	μs			

- NOTES: 11. Characterization data available  
12. All ac current values are RMS unless otherwise noted.  
13.  $\overline{E}$  and  $\overline{G}$  are switched low after power up.  
14. The power supply can switch low concurrently with  $\overline{RP}$  going low.



**TMS28F004Axy, TMS28F400Axy**  
**524288 BY 8-BIT/262144 BY 16-BIT**  
**AUTO-SELECT BOOT-BLOCK FLASH MEMORIES**

SMJS829A – JANUARY 1996 – REVISED AUGUST 1997

switching characteristics for TMS28F004AFy and TMS28F400AFy over recommended ranges of supply voltage (commercial and extended temperature ranges)

read operations

PARAMETER	ALT. SYMBOL	'28F004AFy60 '28F400AFy60	'28F004AFy70 '28F400AFy70	'28F004AFy80 '28F400AFy80	UNIT			
		5-V V <sub>CC</sub> RANGE		5-V V <sub>CC</sub> RANGE				
		MIN	MAX	MIN		MAX	MIN	MAX
t <sub>a</sub> (A) Access time from A0–A17 (see Note 15)	t <sub>AVQV</sub>	60		70		80		ns
t <sub>a</sub> (E) Access time from $\overline{E}$	t <sub>ELQV</sub>	60		70		80		ns
t <sub>a</sub> (G) Access time from $\overline{G}$	t <sub>GLQV</sub>	35		40		40		ns
t <sub>c</sub> (R) Cycle time, read	t <sub>AVAV</sub>	60		70		80		ns
t <sub>d</sub> (E) Delay time, $\overline{E}$ low to low-impedance output	t <sub>ELQX</sub>	0		0		0		ns
t <sub>d</sub> (G) Delay time, $\overline{G}$ low to low-impedance output	t <sub>GLQX</sub>	0		0		0		ns
t <sub>dis</sub> (E) Disable time, $\overline{E}$ to high-impedance output	t <sub>EHQZ</sub>	25		30		30		ns
t <sub>dis</sub> (G) Disable time, $\overline{G}$ to high-impedance output	t <sub>GHQZ</sub>	25		30		30		ns
t <sub>h</sub> (D) Hold time, DQ valid from A0–A17, $\overline{E}$ , or $\overline{G}$ , whichever occurs first (see Note 15)	t <sub>AXQX</sub>	0		0		0		ns
t <sub>su</sub> (EB) Setup time, $\overline{BYTE}$ from $\overline{E}$ low	t <sub>ELFL</sub> t <sub>ELFH</sub>	5		5		5		ns
t <sub>d</sub> (RP) Output delay time from $\overline{RP}$ high	t <sub>PHQV</sub>	450		450		450		ns
t <sub>dis</sub> (BL) Disable time, $\overline{BYTE}$ low to DQ8–DQ15 in high-impedance state	t <sub>FLQZ</sub>	25		30		30		ns
t <sub>a</sub> (BH) Access time from $\overline{BYTE}$ going high	t <sub>FHQV</sub>	60		70		80		ns

NOTE 15: A<sub>1</sub>–A17 for byte-wide



**TMS28F004Axy, TMS28F400Axy**  
**524288 BY 8-BIT/262144 BY 16-BIT**  
**AUTO-SELECT BOOT-BLOCK FLASH MEMORIES**

SMJS829A – JANUARY 1996 – REVISED AUGUST 1997

switching characteristics for TMS28F400AFy over recommended ranges of supply voltage (automotive temperature range)

read operations

PARAMETER	ALT. SYMBOL	'28F400AFy70	'28F400AFy80	'28F004AFy90	UNIT		
		'28F400AFy70	'28F400AFy80	'28F400AFy90			
		5-V V <sub>CC</sub> RANGE		5-V V <sub>CC</sub> RANGE			
		MIN	MAX	MIN	MAX		
t <sub>a</sub> (A) Access time from A0–A17 (see Note 15)	t <sub>AVQV</sub>	70		80		90	ns
t <sub>a</sub> (E) Access time from $\overline{E}$	t <sub>ELQV</sub>	70		80		90	ns
t <sub>a</sub> (G) Access time from $\overline{G}$	t <sub>GLQV</sub>	35		40		45	ns
t <sub>c</sub> (R) Cycle time, read	t <sub>AVAV</sub>	70		80		90	ns
t <sub>d</sub> (E) Delay time, $\overline{E}$ low to low-impedance output	t <sub>ELQX</sub>	0		0		0	ns
t <sub>d</sub> (G) Delay time, $\overline{G}$ low to low-impedance output	t <sub>GLQX</sub>	0		0		0	ns
t <sub>dis</sub> (E) Disable time, $\overline{E}$ to high-impedance output	t <sub>EHQZ</sub>	25		30		35	ns
t <sub>dis</sub> (G) Disable time, $\overline{G}$ to high-impedance output	t <sub>GHQZ</sub>	25		30		35	ns
t <sub>h</sub> (D) Hold time, DQ valid from A0–A17, $\overline{E}$ , or $\overline{G}$ , whichever occurs first (see Note 15)	t <sub>AXQX</sub>	0		0		0	ns
t <sub>su</sub> (EB) Setup time, $\overline{BYTE}$ from $\overline{E}$ low	t <sub>ELFL</sub> t <sub>ELFH</sub>	5		5		5	ns
t <sub>d</sub> (RP) Output delay time from $\overline{RP}$ high	t <sub>PHQV</sub>	300		300		300	ns
t <sub>dis</sub> (BL) Disable time, $\overline{BYTE}$ low to DQ8–DQ15 in high-impedance state	t <sub>FLQZ</sub>	30		30		35	ns
t <sub>a</sub> (BH) Access time from $\overline{BYTE}$ going high	t <sub>FHQV</sub>	70		80		90	ns

NOTE 15: A<sub>1</sub>–A17 for byte-wide

**TMS28F004Axy, TMS28F400Axy**  
**524288 BY 8-BIT/262144 BY 16-BIT**  
**AUTO-SELECT BOOT-BLOCK FLASH MEMORIES**

SMJS829A – JANUARY 1996 – REVISED AUGUST 1997

**timing requirements for TMS28F400AFy (commercial and extended temperature ranges)**

**write/erase operations —  $\overline{W}$ -controlled writes**

	ALT. SYMBOL	'28F004AFy60 '28F400AFy60	'28F004AFy70 '28F400AFy70	'28F004AFy80 '28F400AFy80	UNIT			
		5-V V <sub>CC</sub> RANGE		5-V V <sub>CC</sub> RANGE		5-V V <sub>CC</sub> RANGE		
		MIN	MAX	MIN		MAX	MIN	MAX
t <sub>c</sub> (W)	Cycle time, write	t <sub>AVAV</sub>	60	70	80	ns		
t <sub>c</sub> (W)OP	Cycle time, duration of programming operation	t <sub>WHQV1</sub>	6	6	6	μs		
t <sub>c</sub> (W)ERB	Cycle time, erase operation (boot block)	t <sub>WHQV2</sub>	0.3	0.3	0.3	s		
t <sub>c</sub> (W)ERP	Cycle time, erase operation (parameter block)	t <sub>WHQV3</sub>	0.3	0.3	0.3	s		
t <sub>c</sub> (W)ERM	Cycle time, erase operation (main block)	t <sub>WHQV4</sub>	0.6	0.6	0.6	s		
t <sub>d</sub> (RPR)	Delay time, boot-block relock	t <sub>PHBR</sub>	100	100	100	ns		
t <sub>h</sub> (A)	Hold time, A0–A17 (see Note 15)	t <sub>WHAX</sub>	0	0	0	ns		
t <sub>h</sub> (D)	Hold time, DQ valid	t <sub>WHDX</sub>	0	0	0	ns		
t <sub>h</sub> (E)	Hold time, $\overline{E}$	t <sub>WHEH</sub>	0	0	0	ns		
t <sub>h</sub> (VPP)	Hold time, V <sub>PP</sub> from valid status-register bit	t <sub>QVVL</sub>	0	0	0	ns		
t <sub>h</sub> (RP)	Hold time, $\overline{RP}$ at V <sub>HH</sub> from valid status-register bit	t <sub>QVPH</sub>	0	0	0	ns		
t <sub>h</sub> (WP)	Hold time, $\overline{WP}$ from valid status-register bit	t <sub>WHPL</sub>	0	0	0	ns		
t <sub>su</sub> (WP)	Setup time, $\overline{WP}$ before write operation	t <sub>ELPH</sub>	50	50	50	ns		
t <sub>su</sub> (A)	Setup time, A0–A17 (see Note 15)	t <sub>AVWH</sub>	50	50	50	ns		
t <sub>su</sub> (D)	Setup time, DQ	t <sub>DVWH</sub>	50	50	50	ns		
t <sub>su</sub> (E)	Setup time, $\overline{E}$ before write operation	t <sub>ELWL</sub>	0	0	0	ns		
t <sub>su</sub> (RP)	Setup time, $\overline{RP}$ at V <sub>HH</sub> to $\overline{W}$ going high	t <sub>PHHWH</sub>	100	100	100	ns		
t <sub>su</sub> (VPP)1	Setup time, V <sub>PP</sub> to $\overline{W}$ going high	t <sub>VPWH</sub>	100	100	100	ns		
t <sub>w</sub> (W)	Pulse duration, $\overline{W}$ low	t <sub>WLWH</sub>	50	50	50	ns		
t <sub>w</sub> (WH)	Pulse duration, $\overline{W}$ high	t <sub>WHWL</sub>	10	20	30	ns		
t <sub>rec</sub> (RPHW)	Recovery time, $\overline{RP}$ high to $\overline{W}$ going low	t <sub>PHWL</sub>	450	450	450	ns		

NOTE 15: A<sub>-1</sub>–A17 for byte-wide



**TMS28F004Axy, TMS28F400Axy**  
**524288 BY 8-BIT/262144 BY 16-BIT**  
**AUTO-SELECT BOOT-BLOCK FLASH MEMORIES**

SMJS829A – JANUARY 1996 – REVISED AUGUST 1997

**timing requirements for TMS28F400AFy (automotive temperature range)**

**write/erase operations —  $\overline{W}$ -controlled writes (continued)**

	ALT. SYMBOL	'28F004AFy70	'28F004AFy80	'28F004AFy90	UNIT		
		'28F400AFy70	'28F400AFy80	'28F400AFy90			
		5-V V <sub>CC</sub> RANGE		5-V V <sub>CC</sub> RANGE			
		MIN	MAX	MIN	MAX	MIN	MAX
t <sub>c(W)</sub>	Cycle time, write	t <sub>AVAV</sub>	70	80	90	ns	
t <sub>c(W)OP</sub>	Cycle time, duration of programming operation	t <sub>WHQV1</sub>	6	6	7	μs	
t <sub>c(W)ERB</sub>	Cycle time, erase operation (boot block)	t <sub>WHQV2</sub>	0.3	0.3	0.4	s	
t <sub>c(W)ERP</sub>	Cycle time, erase operation (parameter block)	t <sub>WHQV3</sub>	0.3	0.3	0.4	s	
t <sub>c(W)ERM</sub>	Cycle time, erase operation (main block)	t <sub>WHQV4</sub>	0.6	0.6	0.4	s	
t <sub>d(RPR)</sub>	Delay time, boot-block relock	t <sub>PHBR</sub>	100	100	100	ns	
t <sub>h(A)</sub>	Hold time, A <sub>0</sub> –A <sub>17</sub> (see Note 15)	t <sub>WHAX</sub>	0	0	0	ns	
t <sub>h(D)</sub>	Hold time, DQ valid	t <sub>WHDX</sub>	0	0	0	ns	
t <sub>h(E)</sub>	Hold time, $\overline{E}$	t <sub>WHEH</sub>	0	0	0	ns	
t <sub>h(VPP)</sub>	Hold time, V <sub>PP</sub> from valid status-register bit	t <sub>QVVL</sub>	0	0	0	ns	
t <sub>h(RP)</sub>	Hold time, $\overline{RP}$ at V <sub>HH</sub> from valid status-register bit	t <sub>QVPH</sub>	0	0	0	ns	
t <sub>h(WP)</sub>	Hold time, $\overline{WP}$ from valid status-register bit	t <sub>WHPL</sub>	0	0	0	ns	
t <sub>su(WP)</sub>	Setup time, $\overline{WP}$ before write operation	t <sub>ELPH</sub>	50	50	50	ns	
t <sub>su(A)</sub>	Setup time, A <sub>0</sub> –A <sub>17</sub> (see Note 15)	t <sub>AVWH</sub>	50	50	50	ns	
t <sub>su(D)</sub>	Setup time, DQ	t <sub>DVWH</sub>	50	50	50	ns	
t <sub>su(E)</sub>	Setup time, $\overline{E}$ before write operation	t <sub>ELWL</sub>	0	0	0	ns	
t <sub>su(RP)</sub>	Setup time, $\overline{RP}$ at V <sub>HH</sub> to $\overline{W}$ switching high	t <sub>PHHWH</sub>	100	100	100	ns	
t <sub>su(VPP)1</sub>	Setup time, V <sub>PP</sub> to $\overline{W}$ switching high	t <sub>VPWH</sub>	100	100	100	ns	
t <sub>w(W)</sub>	Pulse duration, $\overline{W}$ low	t <sub>WLWH</sub>	60	60	60	ns	
t <sub>w(WH)</sub>	Pulse duration, $\overline{W}$ high	t <sub>WHWL</sub>	20	30	40	ns	
t <sub>rec(RPHW)</sub>	Recovery time, $\overline{RP}$ high to $\overline{W}$ going low	t <sub>PHWL</sub>	220	220	220	ns	

NOTE 15: A<sub>1</sub>–A<sub>17</sub> for byte-wide

**TMS28F004Axy, TMS28F400Axy**  
**524288 BY 8-BIT/262144 BY 16-BIT**  
**AUTO-SELECT BOOT-BLOCK FLASH MEMORIES**

SMJS829A – JANUARY 1996 – REVISED AUGUST 1997

**timing requirements for TMS28F400AFy (commercial and extended temperature ranges)**

**write/erase operations —  $\bar{E}$ -controlled writes**

	ALT. SYMBOL	'28F004AFy60 '28F400AFy60	'28F004AFy70 '28F400AFy70	'28F004AFy80 '28F400AFy80	UNIT			
		5-V V <sub>CC</sub> RANGE		5-V V <sub>CC</sub> RANGE		5-V V <sub>CC</sub> RANGE		
		MIN	MAX	MIN		MAX	MIN	MAX
t <sub>c</sub> (E) Cycle time, write	t <sub>AVAV</sub>	60	70	80	ns			
t <sub>c</sub> (E)OP Cycle time, duration of programming operation	t <sub>EHQV1</sub>	6	6	6	μs			
t <sub>c</sub> (E)ERB Cycle time, erase operation (boot block)	t <sub>EHQV2</sub>	0.3	0.3	0.3	s			
t <sub>c</sub> (E)ERP Cycle time, erase operation (parameter block)	t <sub>EHQV3</sub>	0.3	0.3	0.3	s			
t <sub>c</sub> (E)ERM Cycle time, erase operation (main block)	t <sub>EHQV4</sub>	0.6	0.6	0.6	s			
t <sub>d</sub> (RPR) Delay time, boot-block relock	t <sub>PHBR</sub>	100	100	100	ns			
t <sub>h</sub> (A) Hold time, A0–A17 (see Note 15)	t <sub>EHAX</sub>	0	0	0	ns			
t <sub>h</sub> (D) Hold time, DQ valid	t <sub>EHDX</sub>	0	0	0	ns			
t <sub>h</sub> (W) Hold time, $\bar{W}$	t <sub>EHWH</sub>	0	0	0	ns			
t <sub>h</sub> (VPP) Hold time, V <sub>PP</sub> from valid status-register bit	t <sub>QVVL</sub>	0	0	0	ns			
t <sub>h</sub> (RP) Hold time, $\bar{RP}$ at V <sub>HH</sub> from valid status-register bit	t <sub>QVPH</sub>	0	0	0	ns			
t <sub>h</sub> (WP) Hold time, $\bar{WP}$ from valid status-register bit	t <sub>WHPL</sub>	0	0	0	ns			
t <sub>su</sub> (WP) Setup time, $\bar{WP}$ before write operation	t <sub>ELPH</sub>	50	50	50	ns			
t <sub>su</sub> (A) Setup time, A0–A17 (see Note 15)	t <sub>AVEH</sub>	50	50	50	ns			
t <sub>su</sub> (D) Setup time, DQ	t <sub>DVEH</sub>	50	50	50	ns			
t <sub>su</sub> (W) Setup time, $\bar{W}$ before write operation	t <sub>WLEL</sub>	0	0	0	ns			
t <sub>su</sub> (RP) Setup time, $\bar{RP}$ at V <sub>HH</sub> to $\bar{E}$ going high	t <sub>PHHEH</sub>	100	100	100	ns			
t <sub>su</sub> (VPP)2 Setup time, V <sub>PP</sub> to $\bar{E}$ going high	t <sub>VPEH</sub>	100	100	100	ns			
t <sub>w</sub> (E) Pulse duration, $\bar{E}$ low	t <sub>ELEH</sub>	50	50	50	ns			
t <sub>w</sub> (EH) Pulse duration, $\bar{E}$ high	t <sub>EHEL</sub>	10	20	30	ns			
t <sub>rec</sub> (RPHE) Recovery time, $\bar{RP}$ high to $\bar{E}$ going low	t <sub>PEHL</sub>	450	450	450	ns			

NOTE 15: A<sub>1</sub>–A17 for byte-wide



**TMS28F004Axy, TMS28F400Axy**  
**524288 BY 8-BIT/262144 BY 16-BIT**  
**AUTO-SELECT BOOT-BLOCK FLASH MEMORIES**

SMJS829A – JANUARY 1996 – REVISED AUGUST 1997

**timing requirements for TMS28F400AFy (automotive temperature range)**

**write/erase operations —  $\overline{E}$ -controlled writes (continued)**

	ALT. SYMBOL	'28F004AFy70	'28F004AFy80	'28F004AFy90	UNIT		
		'28F400AFy70	'28F400AFy80	'28F400AFy90			
		5-V V <sub>CC</sub> RANGE		5-V V <sub>CC</sub> RANGE			
		MIN	MAX	MIN	MAX	MIN	MAX
t <sub>c</sub> (E)	Cycle time, write	t <sub>AVAV</sub>	70	80	90	ns	
t <sub>c</sub> (E)OP	Cycle time, duration of programming operation	t <sub>EHQV1</sub>	6	6	7	μs	
t <sub>c</sub> (E)ERB	Cycle time, erase operation (boot block)	t <sub>EHQV2</sub>	0.3	0.3	0.4	s	
t <sub>c</sub> (E)ERP	Cycle time, erase operation (parameter block)	t <sub>EHQV3</sub>	0.3	0.3	0.4	s	
t <sub>c</sub> (E)ERM	Cycle time, erase operation (main block)	t <sub>EHQV4</sub>	0.6	0.6	0.7	s	
t <sub>d</sub> (RPR)	Delay time, boot-block relock	t <sub>PHBR</sub>	100	100	100	ns	
t <sub>h</sub> (A)	Hold time, A0–A17 (see Note 15)	t <sub>EHAX</sub>	0	0	0	ns	
t <sub>h</sub> (D)	Hold time, DQ valid	t <sub>EHDX</sub>	0	0	0	ns	
t <sub>h</sub> (W)	Hold time, $\overline{W}$	t <sub>EHWH</sub>	0	0	0	ns	
t <sub>h</sub> (VPP)	Hold time, V <sub>PP</sub> from valid status-register bit	t <sub>QVVL</sub>	0	0	0	ns	
t <sub>h</sub> (RP)	Hold time, $\overline{RP}$ at V <sub>HH</sub> from valid status-register bit	t <sub>QVPH</sub>	0	0	0	ns	
t <sub>h</sub> (WP)	Hold time, $\overline{WP}$ from valid status-register bit	t <sub>WHPL</sub>	0	0	0	ns	
t <sub>su</sub> (WP)	Setup time, $\overline{WP}$ before write operation	t <sub>ELPH</sub>	50	50	50	ns	
t <sub>su</sub> (A)	Setup time, A0–A17 (see Note 15)	t <sub>AVEH</sub>	50	50	50	ns	
t <sub>su</sub> (D)	Setup time, DQ valid	t <sub>DVEH</sub>	50	50	50	ns	
t <sub>su</sub> (W)	Setup time, $\overline{W}$ before write operation	t <sub>WLEL</sub>	0	0	0	ns	
t <sub>su</sub> (RP)	Setup time, $\overline{RP}$ at V <sub>HH</sub> to $\overline{E}$ going high	t <sub>PHHEH</sub>	100	100	50	ns	
t <sub>su</sub> (VPP)2	Setup time, V <sub>PP</sub> to $\overline{E}$ going high	t <sub>VPEH</sub>	100	100	50	ns	
t <sub>w</sub> (E)	Pulse duration, $\overline{E}$ low	t <sub>ELEH</sub>	60	60	60	ns	
t <sub>w</sub> (EH)	Pulse duration, $\overline{E}$ high	t <sub>EHEL</sub>	20	30	40	ns	
t <sub>rec</sub> (RPHE)	Recovery time, $\overline{RP}$ high to $\overline{E}$ going low	t <sub>PHEL</sub>	300	300	300	ns	

NOTE 15: A<sub>1</sub>–A17 for byte-wide

**TMS28F004Axy, TMS28F400Axy**  
**524288 BY 8-BIT/262144 BY 16-BIT**  
**AUTO-SELECT BOOT-BLOCK FLASH MEMORIES**

SMJS829A – JANUARY 1996 – REVISED AUGUST 1997

**TMS28F004AZy and TMS28F400AZy**

The TMS28F004AZy and the TMS28F400AZy configurations offer a 5-V memory read with a 12-V program and a 12-V erase for fast programming and erasing times. This configuration is offered in three temperature ranges: 0°C to 70°C, – 40°C to 85°C, and – 40°C to 125°C.

**recommended operating conditions for TMS28F004AZy and TMS28F400AZy**

				MIN	NOM	MAX	UNIT
V <sub>CC</sub>	Supply voltage	During write/read/erase/erase suspend	5-V V <sub>CC</sub> range	4.5	5	5.5	V
V <sub>PP</sub>	Supply voltage	During read only	V <sub>PP</sub> L	0		6.5	V
		During write/erase/erase suspend	12-V V <sub>PP</sub> range	11.4	12	12.6	
V <sub>IH</sub>	High-level dc input voltage	TTL		2		V <sub>CC</sub> + 0.3	V
		CMOS		V <sub>CC</sub> – 0.2		V <sub>CC</sub> + 0.2	
V <sub>IL</sub>	Low-level dc input voltage	TTL		– 0.3		0.8	V
		CMOS		V <sub>SS</sub> – 0.2		V <sub>SS</sub> + 0.2	
V <sub>LKO</sub>	V <sub>CC</sub> lock-out voltage from write/erase (see Note 7)			2			V
V <sub>HH</sub>	RP unlock voltage			11.4	12	13	V
V <sub>PPLK</sub>	V <sub>PP</sub> lock-out voltage from write/erase			0		1.5	V
T <sub>A</sub>	Operating free-air temperature	L Suffix		0		70	°C
		E Suffix		– 40		85	
		Q Suffix		– 40		125	

NOTE 7: Minimum value at T<sub>A</sub> = 25°C.

**word/byte typical write and block-erase performance for TMS28F400AZy and TMS28F004AZy (see Notes 8 and 9)**

PARAMETER	12-V V <sub>PP</sub> AND 5-V V <sub>CC</sub> RANGES		
	MIN	TYP	MAX
Main block-erase time		1.1	14
Main block-byte program time		1.2	4.2
Main block-word program time		0.6	2.1
Parameter/boot-block erase time		0.34	7

NOTES: 8. Typical values shown are at T<sub>A</sub> = 25°C and nominal conditions.  
9. Excludes system-level overhead (all times in seconds)



**TMS28F004Axy, TMS28F400Axy**  
**524288 BY 8-BIT/262144 BY 16-BIT**  
**AUTO-SELECT BOOT-BLOCK FLASH MEMORIES**

SMJS829A – JANUARY 1996 – REVISED AUGUST 1997

**electrical characteristics for TMS28F004AZy and TMS28F400AZy over recommended ranges of supply voltage and operating free-air temperature using test conditions given in Table 9 (unless otherwise noted)**

PARAMETER		TEST CONDITIONS		MIN	MAX	UNIT	
V <sub>OH</sub>	High-level dc output voltage	TTL	V <sub>CC</sub> = V <sub>CC</sub> MIN, I <sub>OH</sub> = - 2.5 mA	2.4		V	
		CMOS	V <sub>CC</sub> = V <sub>CC</sub> MIN, I <sub>OH</sub> = - 100 μA	V <sub>CC</sub> - 0.4			
V <sub>OL</sub>	Low-level dc output voltage	V <sub>CC</sub> = V <sub>CC</sub> MIN, I <sub>OL</sub> = 5.8 mA			0.45	V	
V <sub>ID</sub>	A9 selection code voltage	During read algorithm-selection mode		11.4	12.6	V	
I <sub>I</sub>	Input current (leakage), except for A9 when A9 = V <sub>ID</sub> (see Note 10)	V <sub>CC</sub> = V <sub>CC</sub> MAX, V <sub>I</sub> = 0 V to V <sub>CC</sub> MAX, $\overline{RP}$ = V <sub>HH</sub>			±1	μA	
I <sub>ID</sub>	A9 selection code current	A9 = V <sub>ID</sub>			500	μA	
I <sub>RP</sub>	$\overline{RP}$ boot-block unlock current	$\overline{RP}$ = V <sub>HH</sub>			500	μA	
I <sub>O</sub>	Output current (leakage)	V <sub>CC</sub> = V <sub>CC</sub> MAX, V <sub>O</sub> = 0 V to V <sub>CC</sub> MAX			±10	μA	
I <sub>PPS</sub>	V <sub>PP</sub> standby current (standby)	V <sub>PP</sub> ≤ V <sub>CC</sub>	5-V V <sub>CC</sub> range		10	μA	
I <sub>PPL</sub>	V <sub>PP</sub> supply current (reset/deep power-down mode)	$\overline{RP}$ = V <sub>SS</sub> ± 0.2 V, V <sub>PP</sub> ≤ V <sub>CC</sub>	5-V V <sub>CC</sub> range		5	μA	
I <sub>PP1</sub>	V <sub>PP</sub> supply current (active read)	V <sub>PP</sub> ≥ V <sub>CC</sub>	5-V V <sub>CC</sub> range		200	μA	
I <sub>PP2</sub>	V <sub>PP</sub> supply current (active byte write) (see Notes 11 and 12)	Programming in progress	12-V V <sub>PP</sub> range, 5-V V <sub>CC</sub> range		20	mA	
I <sub>PP3</sub>	V <sub>PP</sub> supply current (active word write) (see Notes 11 and 12)	Programming in progress	12-V V <sub>PP</sub> range, 5-V V <sub>CC</sub> range		20	mA	
I <sub>PP4</sub>	V <sub>PP</sub> supply current (block erase) (see Notes 11 and 12)	Block erase in progress	12-V V <sub>PP</sub> range, 5-V V <sub>CC</sub> range		15	mA	
I <sub>PP5</sub>	V <sub>PP</sub> supply current (erase suspend) (see Notes 11 and 12)	Block erase suspended	12-V V <sub>PP</sub> range, 5-V V <sub>CC</sub> range		200	μA	
I <sub>CCS</sub>	V <sub>CC</sub> supply current (standby)	TTL-input level	V <sub>CC</sub> = V <sub>CC</sub> MAX, $\overline{E}$ = $\overline{RP}$ = V <sub>IH</sub>	5-V V <sub>CC</sub> range		2	mA
		CMOS-input level					
I <sub>CCL</sub>	V <sub>CC</sub> supply current (reset/deep power-down mode)	$\overline{RP}$ = V <sub>SS</sub> ± 0.2 V		0°C to 70°C		8	μA
				- 40°C to 85°C		8	
				- 40°C to 125°C		40	
I <sub>CC1</sub>	V <sub>CC</sub> supply current (active read)	TTL-input level	$\overline{E}$ = V <sub>IL</sub> , I <sub>OUT</sub> = 0 mA, f = 10 MHz, $\overline{G}$ = V <sub>IH</sub>	5-V V <sub>CC</sub> range		65	mA
		CMOS-input level	$\overline{E}$ = V <sub>SS</sub> , I <sub>OUT</sub> = 0 mA, f = 10 MHz, $\overline{G}$ = V <sub>CC</sub>	5-V V <sub>CC</sub> range		60	mA
I <sub>CC2</sub>	V <sub>CC</sub> supply current (active byte write) (see Notes 11 and 12)	V <sub>CC</sub> = V <sub>CC</sub> MAX, Programming in progress	12-V V <sub>PP</sub> range, 5-V V <sub>CC</sub> range		50	mA	
I <sub>CC3</sub>	V <sub>CC</sub> supply current (active word write) (see Notes 11 and 12)	V <sub>CC</sub> = V <sub>CC</sub> MAX, Programming in progress	12-V V <sub>PP</sub> range, 5-V V <sub>CC</sub> range		45	mA	
I <sub>CC4</sub>	V <sub>CC</sub> supply current (block erase) (see Notes 11 and 12)	V <sub>CC</sub> = V <sub>CC</sub> MAX, Block erase in progress	12-V V <sub>PP</sub> range, 5-V V <sub>CC</sub> range		45	mA	
I <sub>CC5</sub>	V <sub>CC</sub> supply current (erase suspend) (see Notes 11 and 12)	V <sub>CC</sub> = V <sub>CC</sub> MAX, $\overline{E}$ = V <sub>IH</sub> , Block erase suspended	5-V V <sub>CC</sub> range		10	mA	

NOTES: 10. DQ15/A<sub>1</sub> is tested for output leakage only.  
11. Not 100% tested; characterization data available  
12. All ac current values are RMS unless otherwise noted.



**TMS28F004Axy, TMS28F400Axy**  
**524288 BY 8-BIT/262144 BY 16-BIT**  
**AUTO-SELECT BOOT-BLOCK FLASH MEMORIES**

SMJS829A – JANUARY 1996 – REVISED AUGUST 1997

power-up and reset switching characteristics for TMS28F004AZy and TMS28F400AZy over recommended ranges of supply voltage (commercial and extended temperature ranges) (see Notes 11, 12, and 13)

PARAMETER	ALT. SYMBOL	'28F004AZy60 '28F400AZy60	'28F004AZy70 '28F400AZy70	'28F004AZy80 '28F400AZy80	UNIT			
		5-V V <sub>CC</sub> RANGE		5-V V <sub>CC</sub> RANGE		5-V V <sub>CC</sub> RANGE		
		MIN	MAX	MIN		MAX	MIN	MAX
t <sub>su</sub> (V <sub>CC</sub> ) Setup time, $\overline{RP}$ low to V <sub>CC</sub> at 4.5 V MIN (see Note 14)	t <sub>PL5V</sub> t <sub>PL3V</sub>	0	0	0	ns			
t <sub>a</sub> (DV) Address valid to data valid	t <sub>AVQV</sub>	60	70	80	ns			
t <sub>su</sub> (DV) Setup time, $\overline{RP}$ high to data valid	t <sub>PHQV</sub>	450	450	450	ns			
t <sub>h</sub> (RP5) Hold time, V <sub>CC</sub> at 4.5 V (MIN) to $\overline{RP}$ high	t <sub>5VPH</sub>	2	2	2	μs			

- NOTES: 11. Characterization data available  
12. All ac current values are RMS unless otherwise noted.  
13.  $\overline{E}$  and  $\overline{G}$  are switched low after power up.  
14. The power supply can switch low concurrently with  $\overline{RP}$  going low.

power-up and reset switching characteristics for TMS28F400AZy over recommended ranges of supply voltage (automotive temperature range)

PARAMETER	ALT. SYMBOL	'28F004AZy70 '28F400AZy70	'28F004AZy80 '28F400AZy80	'28F004AZy90 '28F400AZy90	UNIT			
		5-V V <sub>CC</sub> RANGE		5-V V <sub>CC</sub> RANGE		5-V V <sub>CC</sub> RANGE		
		MIN	MAX	MIN		MAX	MIN	MAX
t <sub>su</sub> (V <sub>CC</sub> ) Setup time, $\overline{RP}$ low to V <sub>CC</sub> at 4.5 V MIN (see Note 14)	t <sub>PL5V</sub> t <sub>PL3V</sub>	0	0	0	ns			
t <sub>a</sub> (DV) Address valid to data valid	t <sub>AVQV</sub>	70	80	90	ns			
t <sub>su</sub> (DV) Setup time, $\overline{RP}$ high to data valid	t <sub>PHQV</sub>	450	450	450	ns			
t <sub>h</sub> (RP5) Hold time, V <sub>CC</sub> at 4.5 V (MIN) to $\overline{RP}$ high	t <sub>5VPH</sub>	2	2	2	μs			

- NOTES: 11. Characterization data available  
12. All ac current values are RMS unless otherwise noted.  
13.  $\overline{E}$  and  $\overline{G}$  are switched low after power up.  
14. The power supply can switch low concurrently with  $\overline{RP}$  going low.



**TMS28F004Axy, TMS28F400Axy**  
**524288 BY 8-BIT/262144 BY 16-BIT**  
**AUTO-SELECT BOOT-BLOCK FLASH MEMORIES**

SMJS829A – JANUARY 1996 – REVISED AUGUST 1997

**switching characteristics for TMS28F004AZy and TMS28F400AZy over recommended ranges of supply voltage (commercial and extended temperature ranges)**

**read operations**

PARAMETER	ALT. SYMBOL	'28F004AZy 60	'28F004AZy 70	'28F004AZy 80	UNIT			
		'28F400AZy 60	'28F400AZy 70	'28F400AZy 80				
		5-V V <sub>CC</sub> RANGE		5-V V <sub>CC</sub> RANGE				
		MIN	MAX	MIN	MAX	MIN	MAX	
t <sub>a</sub> (A) Access time from A0–A17 (see Note 15)	t <sub>AVQV</sub>	60		70		80		ns
t <sub>a</sub> (E) Access time from $\overline{E}$	t <sub>ELQV</sub>	60		70		80		ns
t <sub>a</sub> (G) Access time from $\overline{G}$	t <sub>GLQV</sub>	35		40		40		ns
t <sub>c</sub> (R) Cycle time, read	t <sub>AVAV</sub>	60		70		80		ns
t <sub>d</sub> (E) Delay time, $\overline{E}$ low to low-impedance output	t <sub>ELQX</sub>	0		0		0		ns
t <sub>d</sub> (G) Delay time, $\overline{G}$ low to low-impedance output	t <sub>GLQX</sub>	0		0		0		ns
t <sub>dis</sub> (E) Disable time, $\overline{E}$ to high-impedance output	t <sub>EHQZ</sub>	25		30		30		ns
t <sub>dis</sub> (G) Disable time, $\overline{G}$ to high-impedance output	t <sub>GHQZ</sub>	25		30		30		ns
t <sub>h</sub> (D) Hold time, DQ valid from A0–A17, $\overline{E}$ , or $\overline{G}$ , whichever occurs first (see Note 15)	t <sub>AXQX</sub>	0		0		0		ns
t <sub>su</sub> (EB) Setup time, $\overline{BYTE}$ from $\overline{E}$ low	t <sub>ELFL</sub> t <sub>ELFH</sub>	5		5		5		ns
t <sub>d</sub> (RP) Output delay time from $\overline{RP}$ high	t <sub>PHQV</sub>	450		450		450		ns
t <sub>dis</sub> (BL) Disable time, $\overline{BYTE}$ low to DQ8–DQ15 in high-impedance state	t <sub>FLQZ</sub>	25		30		30		ns
t <sub>a</sub> (BH) Access time from $\overline{BYTE}$ going high	t <sub>FHQV</sub>	60		70		80		ns

NOTE 15: A<sub>1</sub>–A17 for byte-wide

**switching characteristics for TMS28F400AZy over recommended ranges of supply voltage (automotive temperature range)**

**read operations**

PARAMETER	ALT. SYMBOL	'28F004AZy 70	'28F004AZy 80	'28F004AZy 90	UNIT			
		'28F400AZy 70	'28F400AZy 80	'28F400AZy 90				
		5-V V <sub>CC</sub> RANGE		5-V V <sub>CC</sub> RANGE				
		MIN	MAX	MIN	MAX	MIN	MAX	
t <sub>a</sub> (A) Access time from A0–A17 (see Note 15)	t <sub>AVQV</sub>	70		80		90		ns
t <sub>a</sub> (E) Access time from $\overline{E}$	t <sub>ELQV</sub>	70		80		90		ns
t <sub>a</sub> (G) Access time from $\overline{G}$	t <sub>GLQV</sub>	35		40		45		ns
t <sub>c</sub> (R) Cycle time, read	t <sub>AVAV</sub>	70		80		90		ns
t <sub>d</sub> (E) Delay time, $\overline{E}$ low to low-impedance output	t <sub>ELQX</sub>	0		0		0		ns
t <sub>d</sub> (G) Delay time, $\overline{G}$ low to low-impedance output	t <sub>GLQX</sub>	0		0		0		ns
t <sub>dis</sub> (E) Disable time, $\overline{E}$ to high-impedance output	t <sub>EHQZ</sub>	25		30		35		ns
t <sub>dis</sub> (G) Disable time, $\overline{G}$ to high-impedance output	t <sub>GHQZ</sub>	25		30		35		ns
t <sub>h</sub> (D) Hold time, DQ valid from A0–A17, $\overline{E}$ , or $\overline{G}$ , whichever occurs first (see Note 15)	t <sub>AXQX</sub>	0		0		0		ns
t <sub>su</sub> (EB) Setup time, $\overline{BYTE}$ from $\overline{E}$ low	t <sub>ELFL</sub> t <sub>ELFH</sub>	5		5		5		ns

NOTE 15: A<sub>1</sub>–A17 for byte-wide



**TMS28F004Axy, TMS28F400Axy**  
**524288 BY 8-BIT/262144 BY 16-BIT**  
**AUTO-SELECT BOOT-BLOCK FLASH MEMORIES**

SMJS829A – JANUARY 1996 – REVISED AUGUST 1997

switching characteristics for TMS28F400AZy over recommended ranges of supply voltage (automotive temperature range) (continued)

read operations

PARAMETER	ALT. SYMBOL	'28F004AZy70 '28F400AZy70	'28F004AZy80 '28F400AZy80	'28F004AZy90 '28F400AZy90	UNIT			
		5-V V <sub>CC</sub> RANGE		5-V V <sub>CC</sub> RANGE		5-V V <sub>CC</sub> RANGE		
		MIN	MAX	MIN		MAX	MIN	MAX
t <sub>d</sub> (RP) Output delay time from $\overline{RP}$ high	t <sub>PHQV</sub>	300		300		300		ns
t <sub>dis</sub> (BL) Disable time, $\overline{BYTE}$ low to DQ8–DQ15 in high-impedance state	t <sub>FLQZ</sub>	30		30		35		ns
t <sub>a</sub> (BH) Access time from $\overline{BYTE}$ going high	t <sub>FHQV</sub>	70		80		90		ns

timing requirements for TMS28F004AZy and TMS28F400AZy (commercial and extended temperature ranges)

write/erase operations —  $\overline{W}$ -controlled writes

	ALT. SYMBOL	'28F004AZy60 '28F400AZy60	'28F004AZy70 '28F400AZy70	'28F004AZy80 '28F400AZy80	UNIT			
		5-V V <sub>CC</sub> RANGE		5-V V <sub>CC</sub> RANGE		5-V V <sub>CC</sub> RANGE		
		MIN	MAX	MIN		MAX	MIN	MAX
t <sub>c</sub> (W) Cycle time, write	t <sub>AVAV</sub>	60	70	80	ns			
t <sub>c</sub> (W)OP Cycle time, duration of programming operation	t <sub>WHQV1</sub>	6	6	6	μs			
t <sub>c</sub> (W)ERB Cycle time, erase operation (boot block)	t <sub>WHQV2</sub>	0.3	0.3	0.3	s			
t <sub>c</sub> (W)ERP Cycle time, erase operation (parameter block)	t <sub>WHQV3</sub>	0.3	0.3	0.3	s			
t <sub>c</sub> (W)ERM Cycle time, erase operation (main block)	t <sub>WHQV4</sub>	0.6	0.6	0.6	s			
t <sub>d</sub> (RPR) Delay time, boot-block relock	t <sub>PHBR</sub>	100		100		ns		
t <sub>h</sub> (A) Hold time, A0–A17 (see Note 15)	t <sub>WHAX</sub>	0	0	0	ns			
t <sub>h</sub> (D) Hold time, DQ valid	t <sub>WHDX</sub>	0	0	0	ns			
t <sub>h</sub> (E) Hold time, $\overline{E}$	t <sub>WHEH</sub>	0	0	0	ns			
t <sub>h</sub> (VPP) Hold time, V <sub>PP</sub> from valid status-register bit	t <sub>QVVL</sub>	0	0	0	ns			
t <sub>h</sub> (RP) Hold time, $\overline{RP}$ at V <sub>HH</sub> from valid status-register bit	t <sub>QVPH</sub>	0	0	0	ns			
t <sub>su</sub> (A) Setup time, A0–A17 (see Note 15)	t <sub>AVWH</sub>	50	50	50	ns			
t <sub>su</sub> (D) Setup time, DQ	t <sub>DVWH</sub>	50	50	50	ns			
t <sub>su</sub> (E) Setup time, $\overline{E}$ before write operation	t <sub>ELWL</sub>	0	0	0	ns			
t <sub>su</sub> (RP) Setup time, $\overline{RP}$ at V <sub>HH</sub> to $\overline{W}$ going high	t <sub>PHHWH</sub>	100	100	100	ns			
t <sub>su</sub> (VPP)1 Setup time, V <sub>PP</sub> to $\overline{W}$ going high	t <sub>VPWH</sub>	100	100	100	ns			
t <sub>w</sub> (W) Pulse duration, $\overline{W}$ low	t <sub>WLWH</sub>	50	50	50	ns			
t <sub>w</sub> (WH) Pulse duration, $\overline{W}$ high	t <sub>WHWL</sub>	10	20	30	ns			
t <sub>rec</sub> (RPHW) Recovery time, $\overline{RP}$ high to $\overline{W}$ going low	t <sub>PHWL</sub>	450	450	450	ns			

NOTE 15: A<sub>–1</sub>–A17 for byte-wide



**TMS28F004Axy, TMS28F400Axy**  
**524288 BY 8-BIT/262144 BY 16-BIT**  
**AUTO-SELECT BOOT-BLOCK FLASH MEMORIES**

SMJS829A – JANUARY 1996 – REVISED AUGUST 1997

**timing requirements for TMS28F400AZy (automotive temperature range)**

**write/erase operations —  $\overline{W}$ -controlled writes (continued)**

	ALT. SYMBOL	'28F004AZy60	'28F004AZy70	'28F004AZy80	UNIT		
		'28F400AZy60	'28F400AZy70	'28F400AZy80			
		5-V VCC RANGE		5-V VCC RANGE			
		MIN	MAX	MIN	MAX	MIN	MAX
$t_{c(W)}$	Cycle time, write	$t_{AVAV}$	70	80	90	ns	
$t_{c(W)OP}$	Cycle time, duration of programming operation	$t_{WHQV1}$	6	6	7	$\mu$ s	
$t_{c(W)ERB}$	Cycle time, erase operation (boot block)	$t_{WHQV2}$	0.3	0.3	.4	s	
$t_{c(W)ERP}$	Cycle time, erase operation (parameter block)	$t_{WHQV3}$	0.3	0.3	.4	s	
$t_{c(W)ERM}$	Cycle time, erase operation (main block)	$t_{WHQV4}$	0.6	0.6	.7	s	
$t_{d(RPR)}$	Delay time, boot-block reload	$t_{PHBR}$	100	100	100	ns	
$t_{h(A)}$	Hold time, A0–A17 (see Note 15)	$t_{WHAX}$	0	0	0	ns	
$t_{h(D)}$	Hold time, DQ valid	$t_{WHDX}$	0	0	0	ns	
$t_{h(E)}$	Hold time, $\overline{E}$	$t_{WHEH}$	0	0	0	ns	
$t_{h(VPP)}$	Hold time, $V_{PP}$ from valid status-register bit	$t_{QVVL}$	0	0	0	ns	
$t_{h(RP)}$	Hold time, $\overline{RP}$ at $V_{HH}$ from valid status-register bit	$t_{QVPH}$	0	0	0	ns	
$t_{su(A)}$	Setup time, A0–A17 (see Note 15)	$t_{AVWH}$	50	50	50	ns	
$t_{su(D)}$	Setup time, DQ	$t_{DVWH}$	50	50	50	ns	
$t_{su(E)}$	Setup time, $\overline{E}$ before write operation	$t_{ELWL}$	0	0	0	ns	
$t_{su(RP)}$	Setup time, $\overline{RP}$ at $V_{HH}$ to $\overline{W}$ going high	$t_{PHHWH}$	100	100	100	ns	
$t_{su(VPP)1}$	Setup time, $V_{PP}$ to $\overline{W}$ going high	$t_{VPWH}$	100	100	100	ns	
$t_{w(W)}$	Pulse duration, $\overline{W}$ low	$t_{WLWH}$	60	60	60	ns	
$t_{w(WH)}$	Pulse duration, $\overline{W}$ high	$t_{WHWL}$	20	30	40	ns	
$t_{rec(RPHW)}$	Recovery time, $\overline{RP}$ high to $\overline{W}$ going low	$t_{PHWL}$	220	220	220	ns	

NOTE 15: A<sub>1</sub>–A17 for byte-wide

**TMS28F004Axy, TMS28F400Axy**  
**524288 BY 8-BIT/262144 BY 16-BIT**  
**AUTO-SELECT BOOT-BLOCK FLASH MEMORIES**

SMJS829A – JANUARY 1996 – REVISED AUGUST 1997

timing requirements for TMS28F004AZy and TMS28F400AZy (commercial and extended temperature ranges)

write/erase operations —  $\bar{E}$ -controlled writes

	ALT. SYMBOL	'28F004AZy60 '28F400AZy60	'28F004AZy70 '28F400AZy70	'28F004AZy80 '28F400AZy80	UNIT			
		5-V $V_{CC}$ RANGE		5-V $V_{CC}$ RANGE		5-V $V_{CC}$ RANGE		
		MIN	MAX	MIN		MAX	MIN	MAX
$t_{c(E)}$ Cycle time, write	$t_{AVAV}$	60		70		80		ns
$t_{c(E)OP}$ Cycle time, duration of programming operation	$t_{EHQV1}$	6		6		6		$\mu$ s
$t_{c(E)ERB}$ Cycle time, erase operation (boot block)	$t_{EHQV2}$	0.3		0.3		0.3		s
$t_{c(E)ERP}$ Cycle time, erase operation (parameter block)	$t_{EHQV3}$	0.3		0.3		0.3		s
$t_{c(E)ERM}$ Cycle time, erase operation (main block)	$t_{EHQV4}$	0.6		0.6		0.6		s
$t_d(RPR)$ Delay time, boot-block relock	$t_{PHBR}$		100		100		100	ns
$t_h(A)$ Hold time, A0–A17 (see Note 15)	$t_{EHAX}$	0		0		0		ns
$t_h(D)$ Hold time, DQ valid	$t_{EHDX}$	0		0		0		ns
$t_h(W)$ Hold time, $\bar{W}$	$t_{EHWH}$	0		0		0		ns
$t_h(VPP)$ Hold time, $V_{PP}$ from valid status-register bit	$t_{QVVL}$	0		0		0		ns
$t_h(RP)$ Hold time, $\bar{RP}$ at $V_{HH}$ from valid status-register bit	$t_{QVPH}$	0		0		0		ns
$t_{su}(A)$ Setup time, A0–A17 (see Note 15)	$t_{AVEH}$	50		50		50		ns
$t_{su}(D)$ Setup time, DQ	$t_{DVEH}$	50		50		50		ns
$t_{su}(W)$ Setup time, $\bar{W}$ before write operation	$t_{WLEL}$	0		0		0		ns
$t_{su}(RP)$ Setup time, $\bar{RP}$ at $V_{HH}$ to $\bar{E}$ going high	$t_{PHHEH}$	100		100		100		ns
$t_{su}(VPP)2$ Setup time, $V_{PP}$ to $\bar{E}$ going high	$t_{VPEH}$	100		100		100		ns
$t_w(E)$ Pulse duration, $\bar{E}$ low	$t_{ELEH}$	50		50		50		ns
$t_w(EH)$ Pulse duration, $\bar{E}$ high	$t_{EHEL}$	10		20		30		ns
$t_{rec}(RPHE)$ Recovery time, $\bar{RP}$ high to $\bar{E}$ going low	$t_{PHEL}$	450		450		450		ns

NOTE 15: A<sub>1</sub>–A17 for byte-wide



**TMS28F004Axy, TMS28F400Axy**  
**524288 BY 8-BIT/262144 BY 16-BIT**  
**AUTO-SELECT BOOT-BLOCK FLASH MEMORIES**

SMJS829A – JANUARY 1996 – REVISED AUGUST 1997

**timing requirements for TMS28F400AZy (automotive temperature range)**

**write/erase operations —  $\bar{E}$ -controlled writes (continued)**

	ALT. SYMBOL	'28F004AZy70	'28F004AZy80	'28F004AZy90	UNIT		
		'28F400AZy70	'28F400AZy80	'28F400AZy90			
		5-V V <sub>CC</sub> RANGE		5-V V <sub>CC</sub> RANGE			
		MIN	MAX	MIN	MAX	MIN	MAX
t <sub>c</sub> (E)	Cycle time, write	t <sub>AVAV</sub>	70	80	90	ns	
t <sub>c</sub> (E)OP	Cycle time, duration of programming operation	t <sub>EHQV1</sub>	6	6	7	μs	
t <sub>c</sub> (E)ERB	Cycle time, erase operation (boot block)	t <sub>EHQV2</sub>	0.3	0.3	0.4	s	
t <sub>c</sub> (E)ERP	Cycle time, erase operation (parameter block)	t <sub>EHQV3</sub>	0.3	0.3	0.4	s	
t <sub>c</sub> (E)ERM	Cycle time, erase operation (main block)	t <sub>EHQV4</sub>	0.6	0.6	0.7	s	
t <sub>d</sub> (RPR)	Delay time, boot-block relock	t <sub>PHBR</sub>	100	100	100	ns	
t <sub>h</sub> (A)	Hold time, A0–A17 (see Note 15)	t <sub>EHAX</sub>	0	0	0	ns	
t <sub>h</sub> (D)	Hold time, DQ valid	t <sub>EHDX</sub>	0	0	0	ns	
t <sub>h</sub> (W)	Hold time, $\bar{W}$	t <sub>EHWH</sub>	0	0	0	ns	
t <sub>h</sub> (VPP)	Hold time, V <sub>PP</sub> from valid status-register bit	t <sub>QVVL</sub>	0	0	0	ns	
t <sub>h</sub> (RP)	Hold time, $\bar{R}\bar{P}$ at V <sub>HH</sub> from valid status-register bit	t <sub>QVPH</sub>	0	0	0	ns	
t <sub>su</sub> (A)	Setup time, A0–A17 (see Note 15)	t <sub>AVEH</sub>	50	50	50	ns	
t <sub>su</sub> (D)	Setup time, DQ valid	t <sub>DVEH</sub>	50	50	50	ns	
t <sub>su</sub> (W)	Setup time, $\bar{W}$ before write operation	t <sub>WLEL</sub>	0	0	0	ns	
t <sub>su</sub> (RP)	Setup time, $\bar{R}\bar{P}$ at V <sub>HH</sub> to $\bar{E}$ going high	t <sub>PHHEH</sub>	100	100	100	ns	
t <sub>su</sub> (VPP)2	Setup time, V <sub>PP</sub> to $\bar{E}$ going high	t <sub>VPEH</sub>	100	100	100	ns	
t <sub>w</sub> (E)	Pulse duration, $\bar{E}$ low	t <sub>ELEH</sub>	60	60	60	ns	
t <sub>w</sub> (EH)	Pulse duration, $\bar{E}$ high	t <sub>EHEL</sub>	20	30	40	ns	
t <sub>rec</sub> (RPHE)	Recovery time, $\bar{R}\bar{P}$ high to $\bar{E}$ going low	t <sub>PHEL</sub>	300	300	300	ns	

NOTE 15: A<sub>1</sub>–A17 for byte-wide

**TMS28F004Axy, TMS28F400Axy**  
**524288 BY 8-BIT/262144 BY 16-BIT**  
**AUTO-SELECT BOOT-BLOCK FLASH MEMORIES**  
 SMJS829A - JANUARY 1996 - REVISED AUGUST 1997

PARAMETER MEASUREMENT INFORMATION

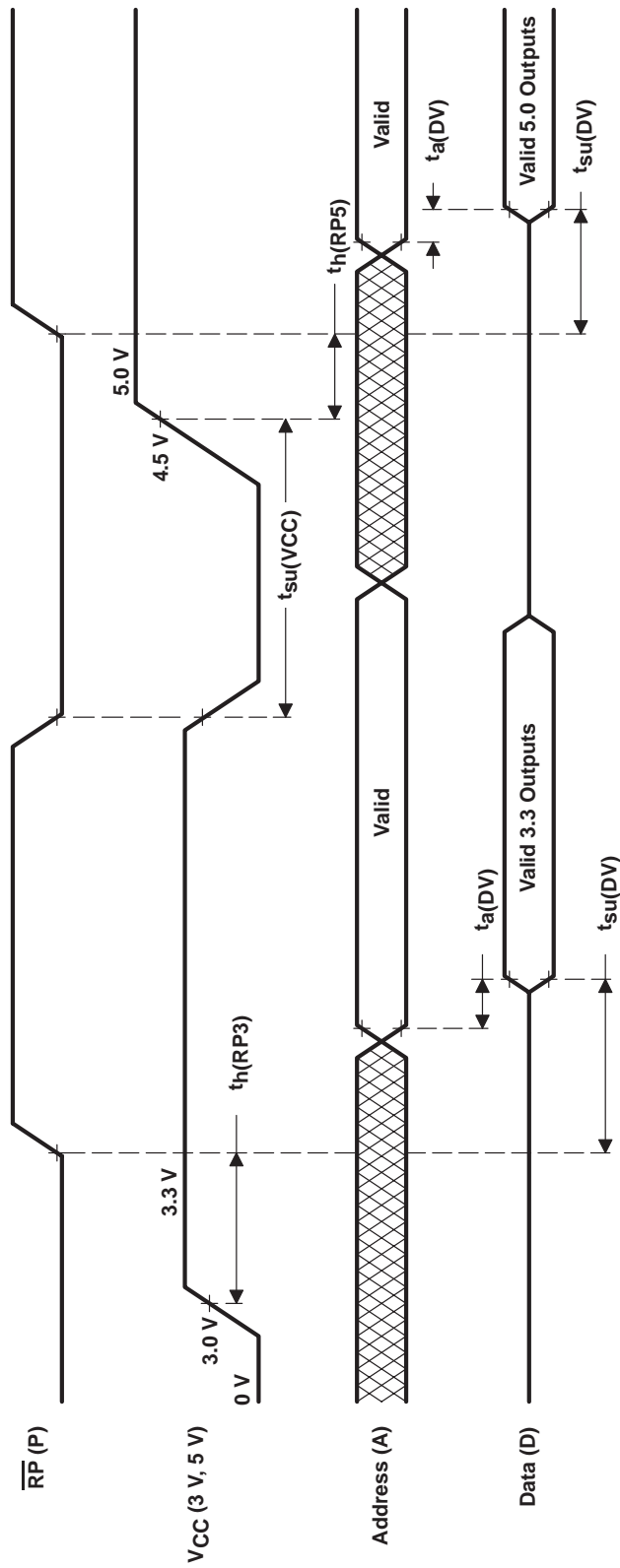

Figure 10. Power-Up Timing and Reset Switching

**PARAMETER MEASUREMENT INFORMATION**

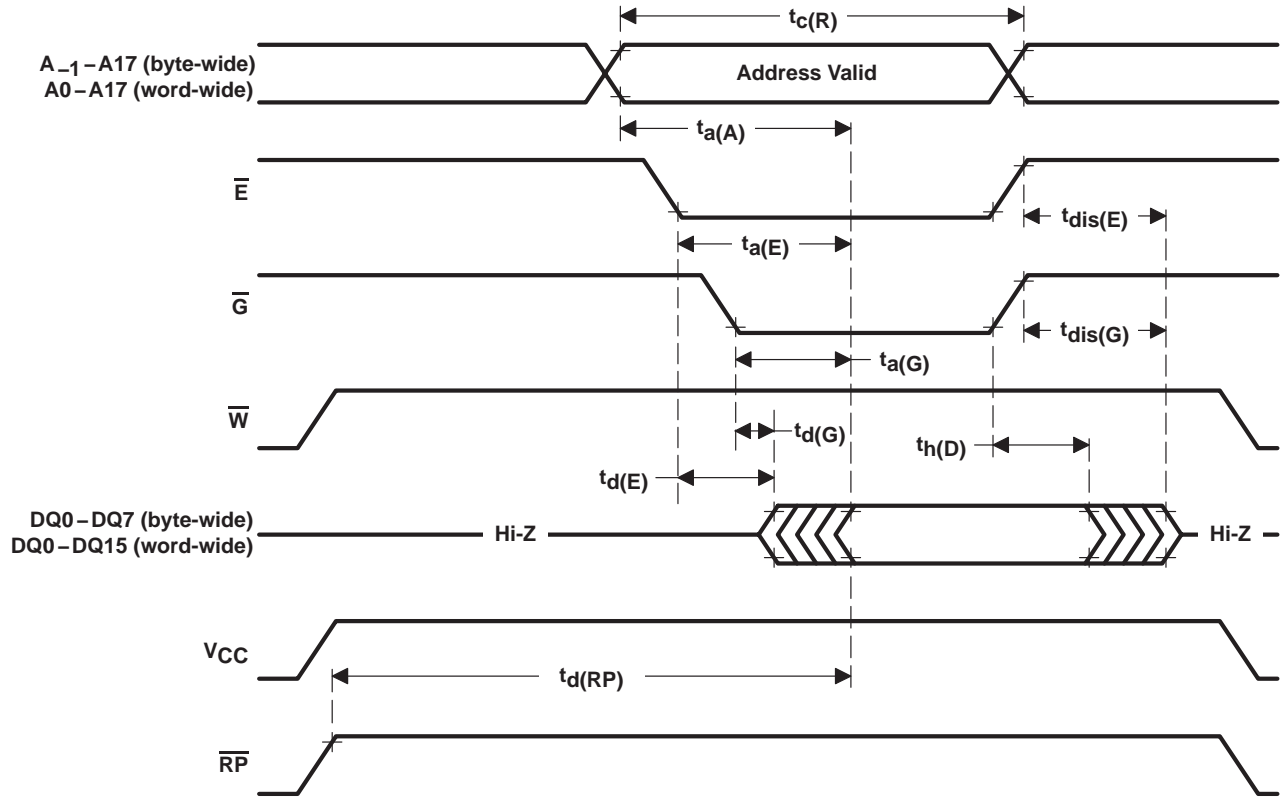
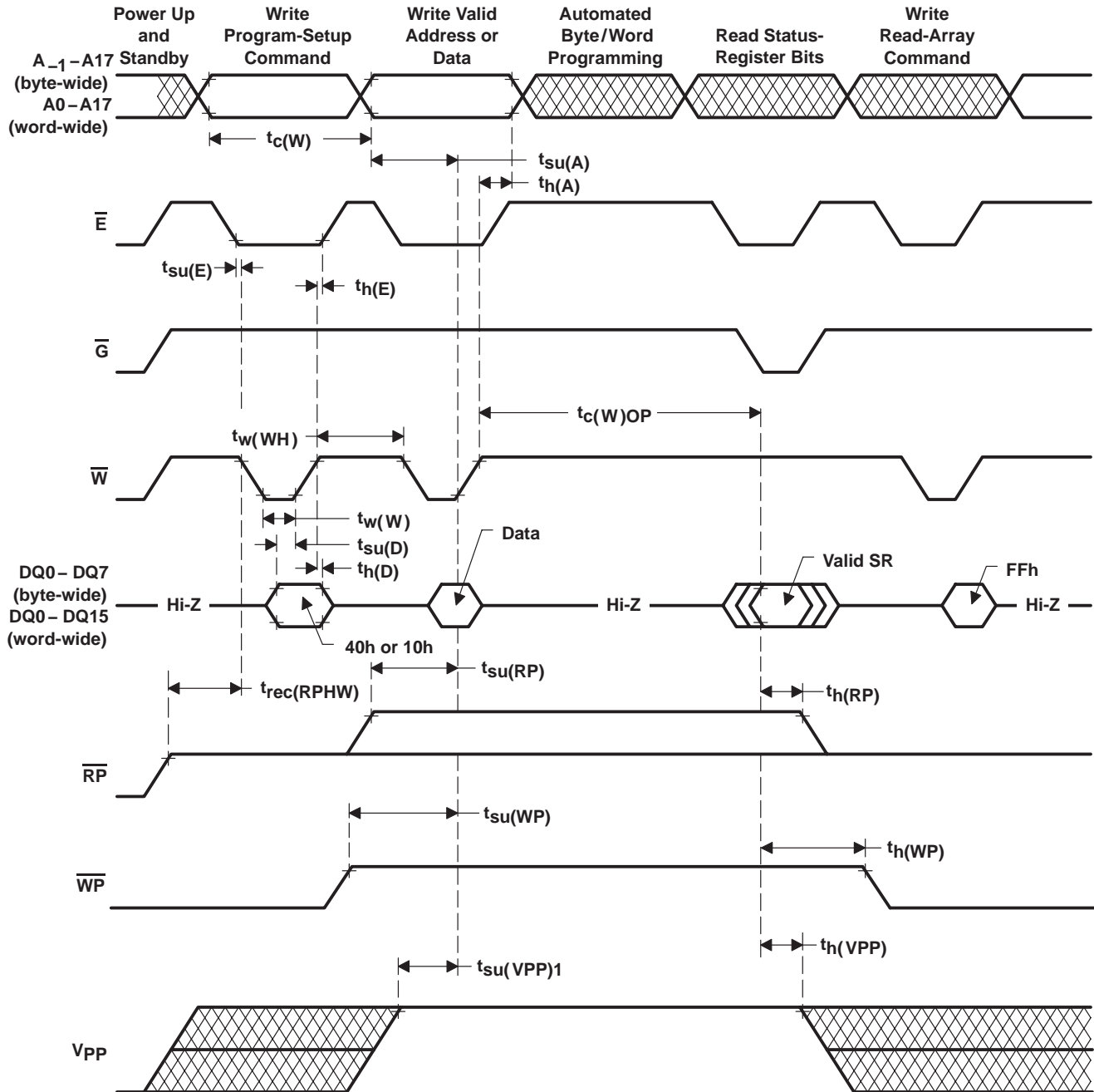

Figure 11. Read-Cycle Timing

**TMS28F004Axy, TMS28F400Axy**  
**524288 BY 8-BIT/262144 BY 16-BIT**  
**AUTO-SELECT BOOT-BLOCK FLASH MEMORIES**

SMJS829A – JANUARY 1996 – REVISED AUGUST 1997

**PARAMETER MEASUREMENT INFORMATION**



**Figure 12. Write-Cycle Timing ( $\overline{W}$ -Controlled Write)**

PARAMETER MEASUREMENT INFORMATION

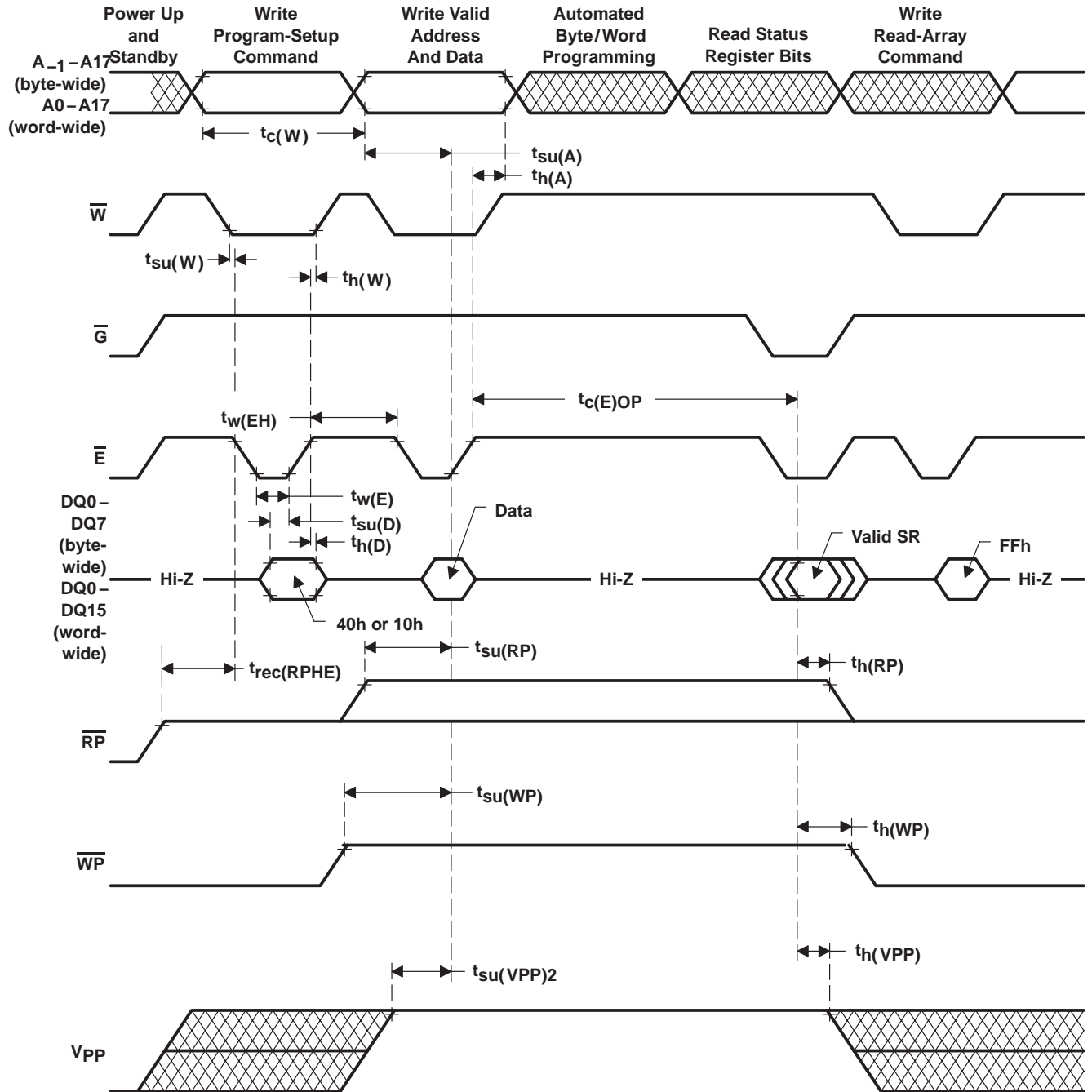

Figure 13. Write-Cycle Timing ( $\bar{E}$ -Controlled Write)

**TMS28F004Axy, TMS28F400Axy**  
**524288 BY 8-BIT/262144 BY 16-BIT**  
**AUTO-SELECT BOOT-BLOCK FLASH MEMORIES**

SMJS829A – JANUARY 1996 – REVISED AUGUST 1997

**PARAMETER MEASUREMENT INFORMATION**

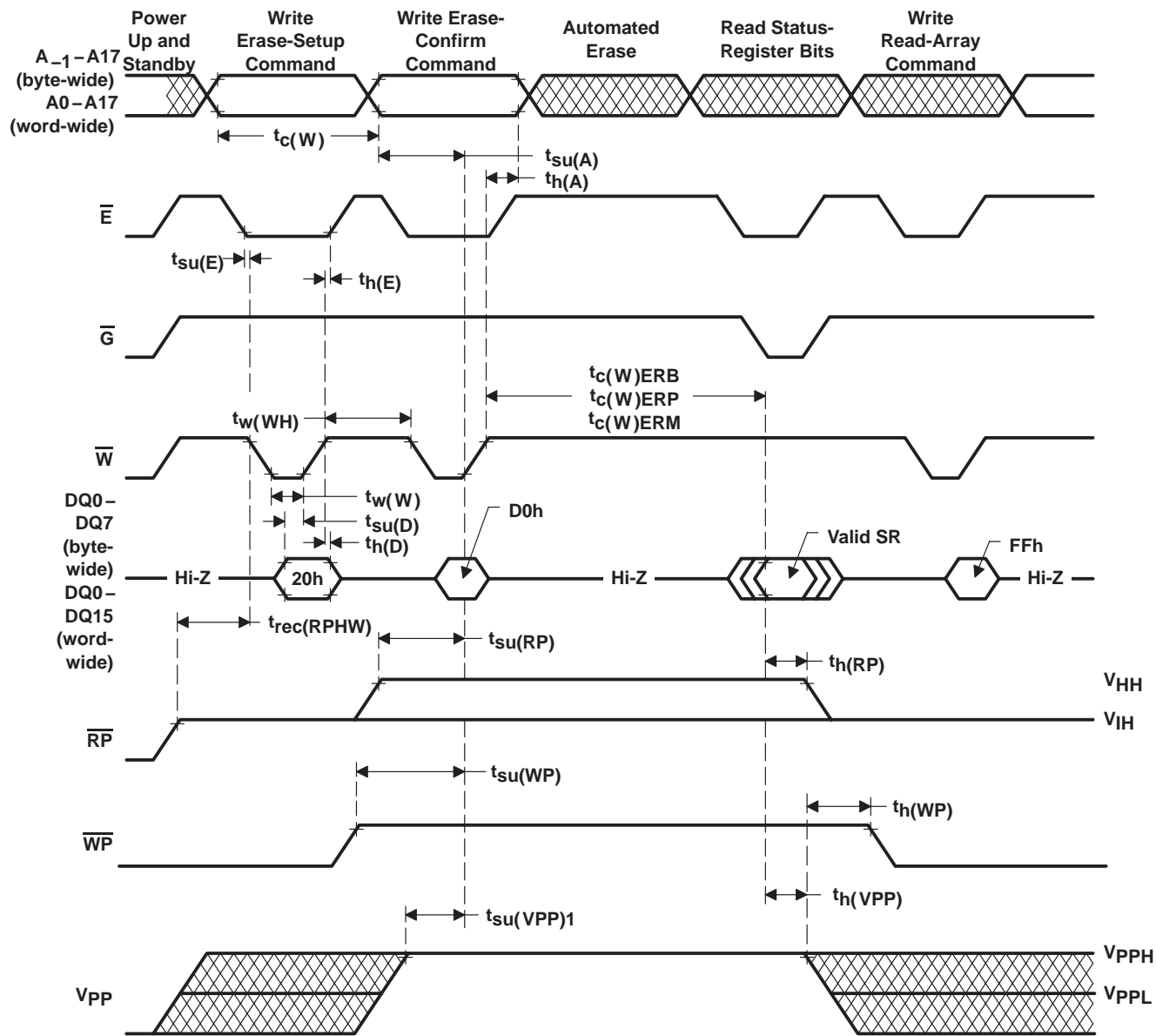

Figure 14. Erase Cycle Timing ( $\overline{W}$ -Controlled Write)

PARAMETER MEASUREMENT INFORMATION

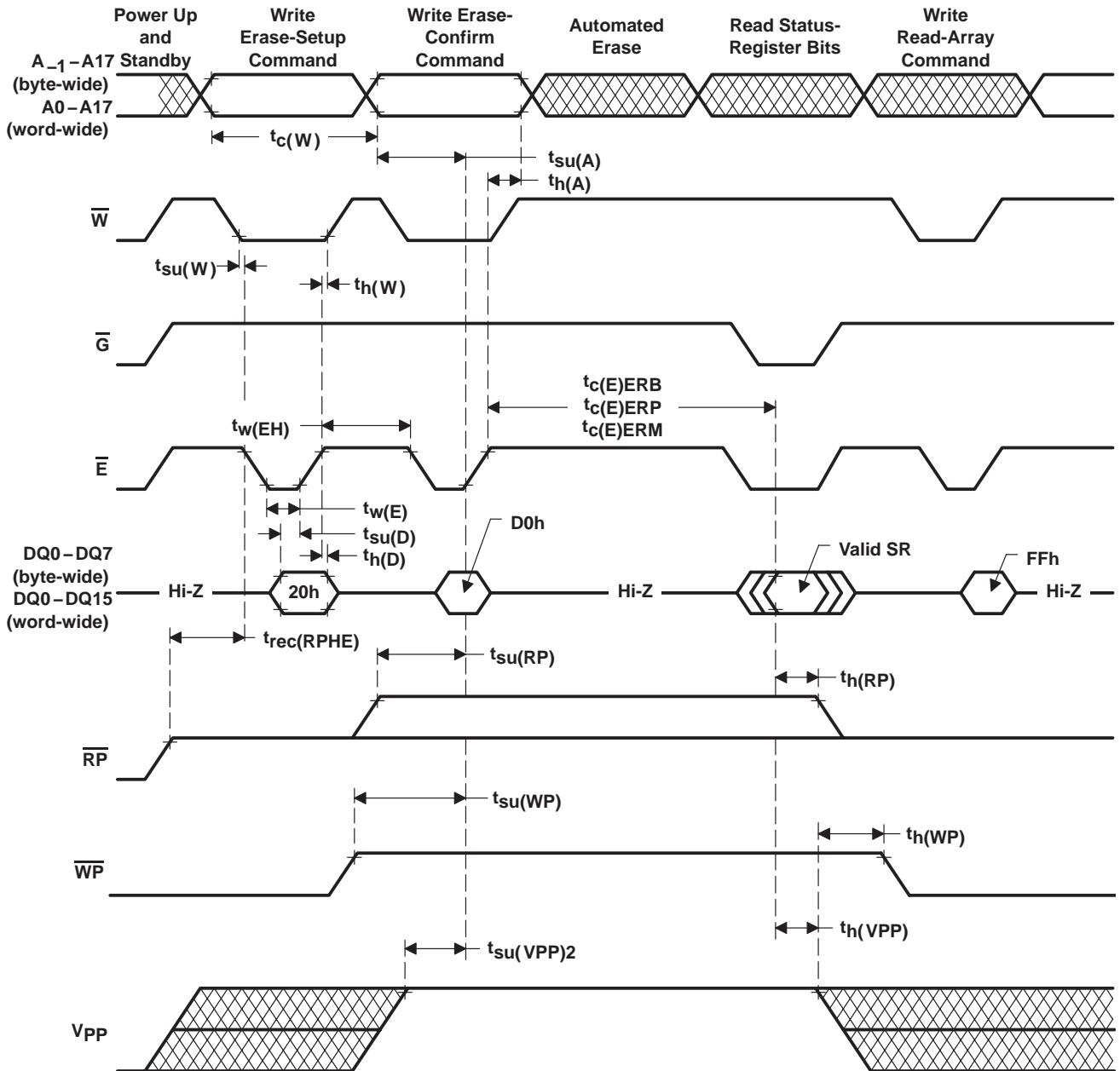
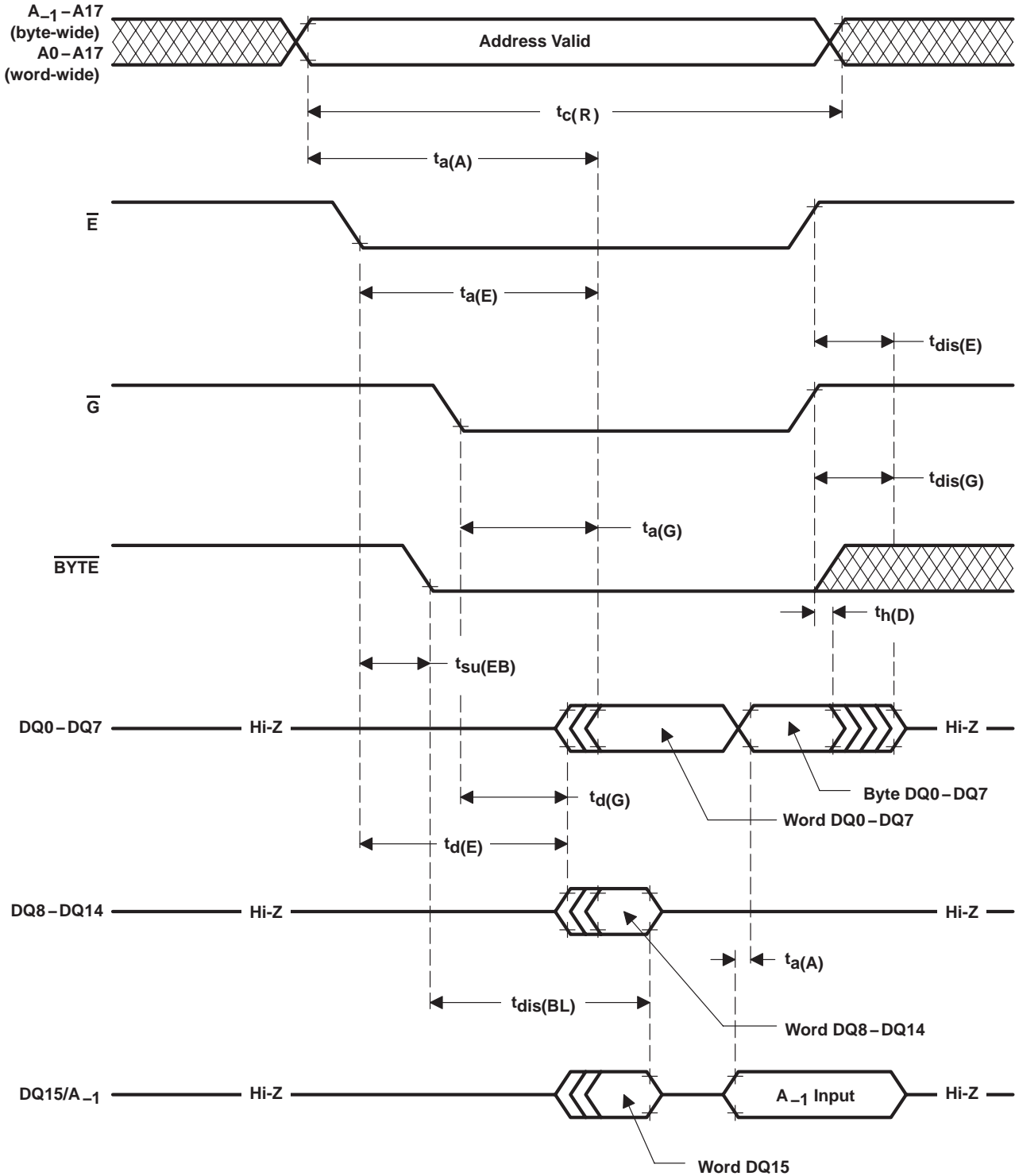

Figure 15. Erase-Cycle Timing ( $\bar{E}$ -Controlled Write)

**TMS28F004Axy, TMS28F400Axy**  
**524288 BY 8-BIT/262144 BY 16-BIT**  
**AUTO-SELECT BOOT-BLOCK FLASH MEMORIES**

SMJS829A – JANUARY 1996 – REVISED AUGUST 1997

**PARAMETER MEASUREMENT INFORMATION**



**Figure 16.  $\overline{\text{BYTE}}$  Timing, Changing From Word-Wide to Byte-Wide Mode**

PARAMETER MEASUREMENT INFORMATION

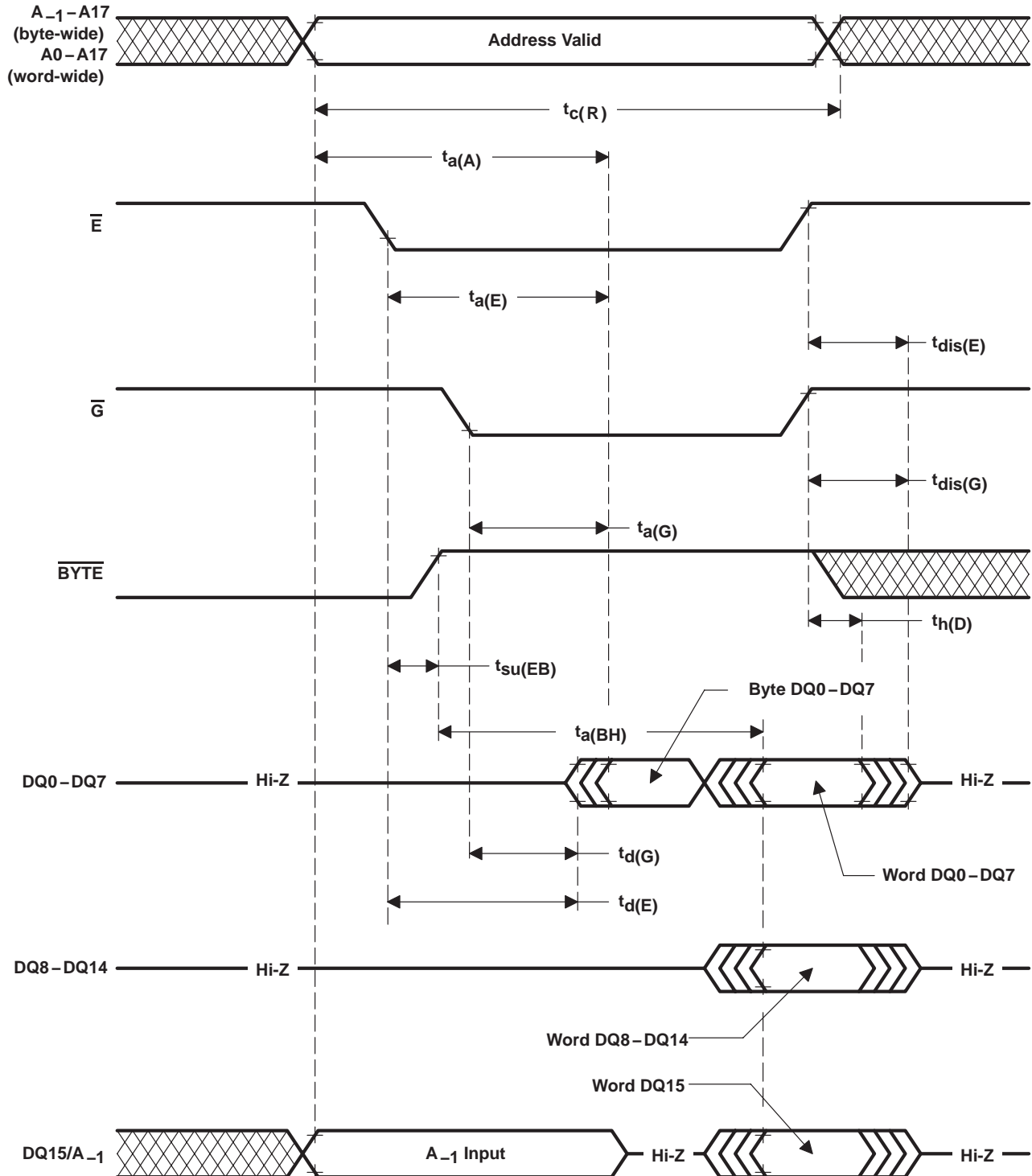

Figure 17.  $\overline{BYTE}$  Timing, Changing From Byte-Wide to Word-Wide Mode

**TMS28F004Axy, TMS28F400Axy**  
**524288 BY 8-BIT/262144 BY 16-BIT**  
**AUTO-SELECT BOOT-BLOCK FLASH MEMORIES**

SMJS829A – JANUARY 1996 – REVISED AUGUST 1997

**MECHANICAL DATA**

**DBJ (R-PDSO-G44)**

**PLASTIC SMALL-OUTLINE PACKAGE**

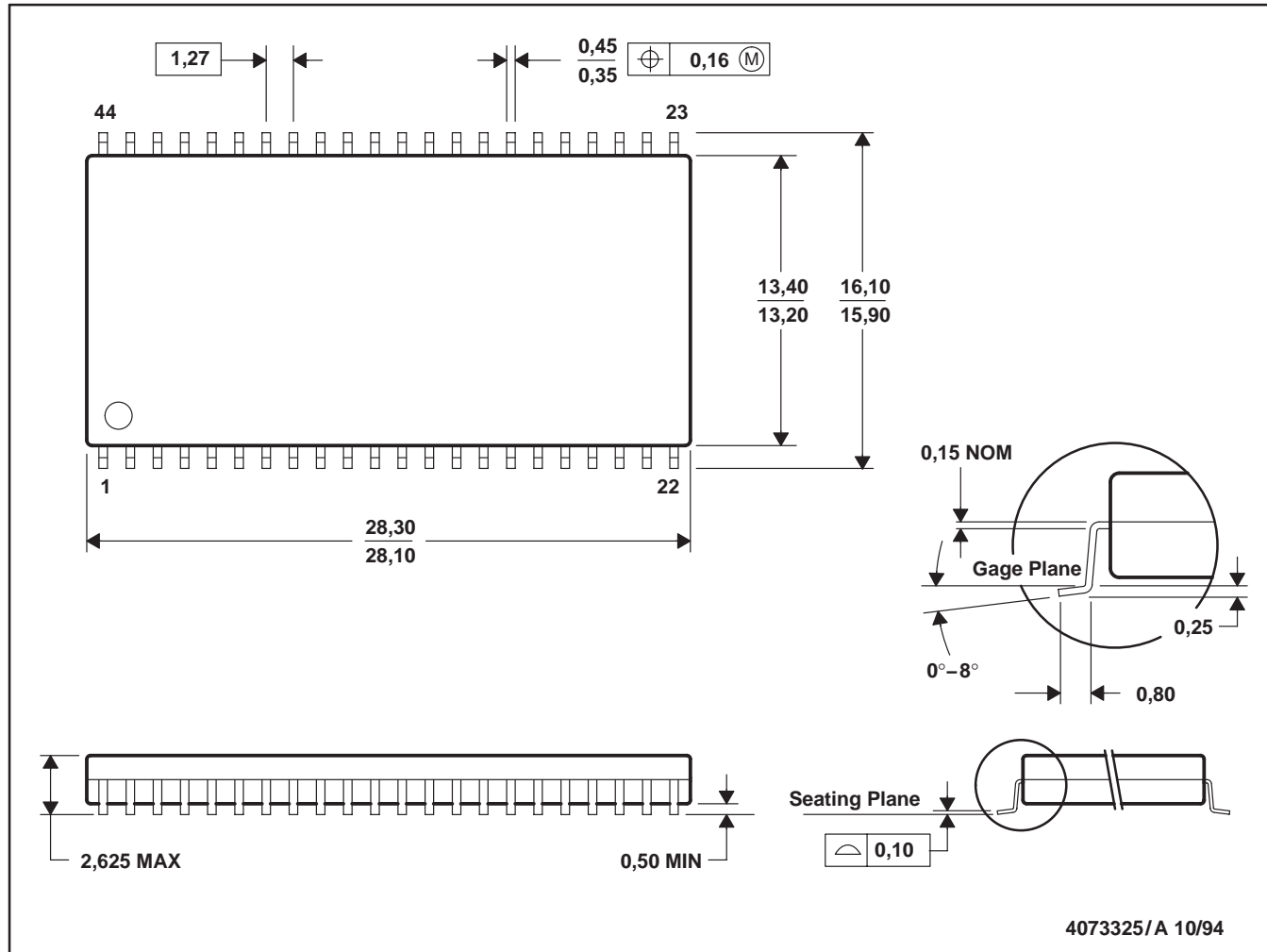

- NOTES: A. All linear dimensions are in millimeters.  
 B. This drawing is subject to change without notice.  
 C. Body dimensions do not include mold flash or protrusion.

**TMS28F004Axy, TMS28F400Axy**  
**524288 BY 8-BIT/262144 BY 16-BIT**  
**AUTO-SELECT BOOT-BLOCK FLASH MEMORIES**

SMJS829A - JANUARY 1996 - REVISED AUGUST 1997

**MECHANICAL DATA**

**DCD (R-PDSO-G\*\*)**

**PLASTIC DUAL SMALL-OUTLINE PACKAGE**

**40 PIN SHOWN**

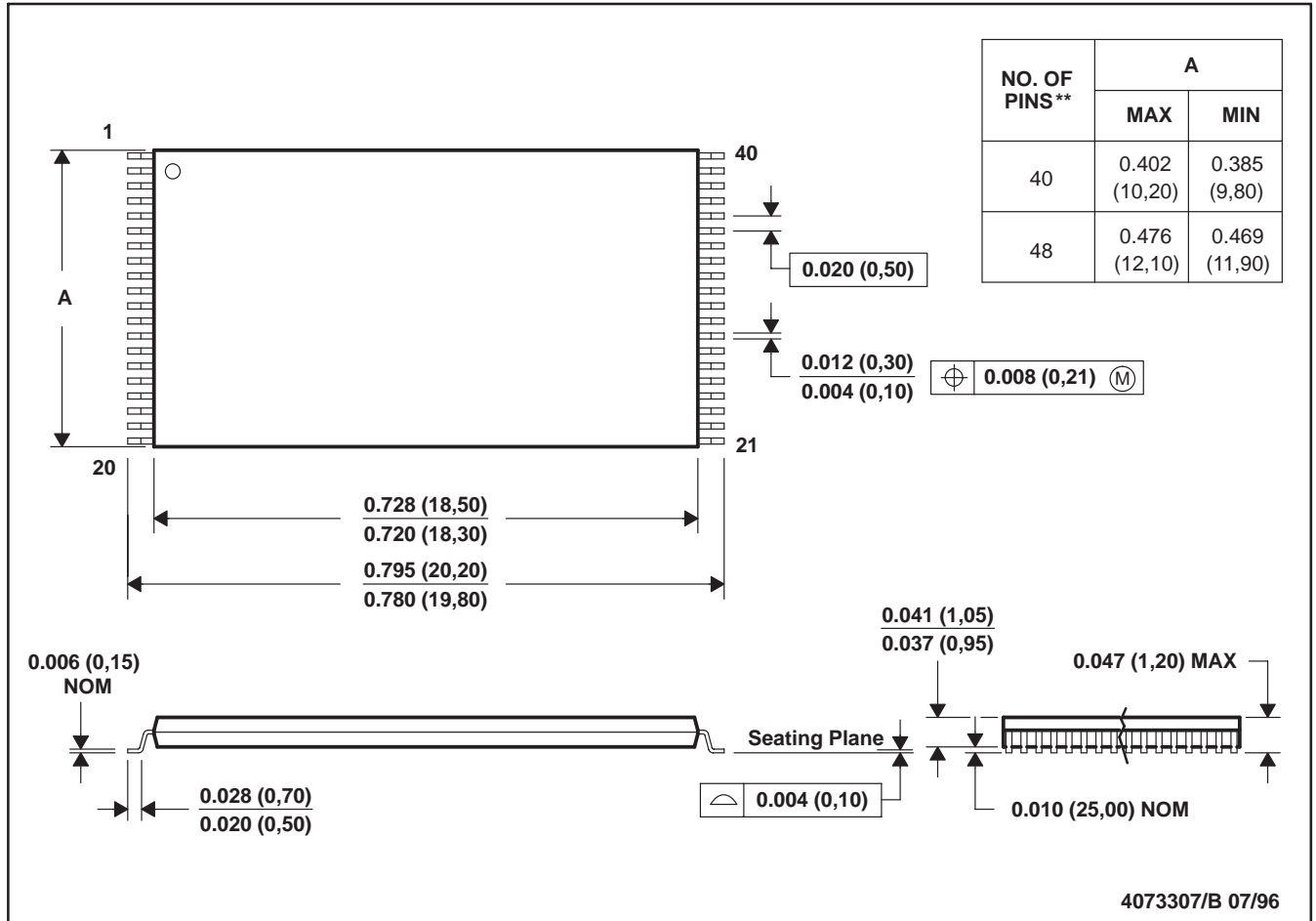

NOTES: A. All linear dimensions are in inches (millimeters).  
 B. This drawing is subject to change without notice.

## IMPORTANT NOTICE

Texas Instruments Incorporated and its subsidiaries (TI) reserve the right to make corrections, modifications, enhancements, improvements, and other changes to its products and services at any time and to discontinue any product or service without notice. Customers should obtain the latest relevant information before placing orders and should verify that such information is current and complete. All products are sold subject to TI's terms and conditions of sale supplied at the time of order acknowledgment.

TI warrants performance of its hardware products to the specifications applicable at the time of sale in accordance with TI's standard warranty. Testing and other quality control techniques are used to the extent TI deems necessary to support this warranty. Except where mandated by government requirements, testing of all parameters of each product is not necessarily performed.

TI assumes no liability for applications assistance or customer product design. Customers are responsible for their products and applications using TI components. To minimize the risks associated with customer products and applications, customers should provide adequate design and operating safeguards.

TI does not warrant or represent that any license, either express or implied, is granted under any TI patent right, copyright, mask work right, or other TI intellectual property right relating to any combination, machine, or process in which TI products or services are used. Information published by TI regarding third-party products or services does not constitute a license from TI to use such products or services or a warranty or endorsement thereof. Use of such information may require a license from a third party under the patents or other intellectual property of the third party, or a license from TI under the patents or other intellectual property of TI.

Reproduction of TI information in TI data books or data sheets is permissible only if reproduction is without alteration and is accompanied by all associated warranties, conditions, limitations, and notices. Reproduction of this information with alteration is an unfair and deceptive business practice. TI is not responsible or liable for such altered documentation. Information of third parties may be subject to additional restrictions.

Resale of TI products or services with statements different from or beyond the parameters stated by TI for that product or service voids all express and any implied warranties for the associated TI product or service and is an unfair and deceptive business practice. TI is not responsible or liable for any such statements.

TI products are not authorized for use in safety-critical applications (such as life support) where a failure of the TI product would reasonably be expected to cause severe personal injury or death, unless officers of the parties have executed an agreement specifically governing such use. Buyers represent that they have all necessary expertise in the safety and regulatory ramifications of their applications, and acknowledge and agree that they are solely responsible for all legal, regulatory and safety-related requirements concerning their products and any use of TI products in such safety-critical applications, notwithstanding any applications-related information or support that may be provided by TI. Further, Buyers must fully indemnify TI and its representatives against any damages arising out of the use of TI products in such safety-critical applications.

TI products are neither designed nor intended for use in military/aerospace applications or environments unless the TI products are specifically designated by TI as military-grade or "enhanced plastic." Only products designated by TI as military-grade meet military specifications. Buyers acknowledge and agree that any such use of TI products which TI has not designated as military-grade is solely at the Buyer's risk, and that they are solely responsible for compliance with all legal and regulatory requirements in connection with such use.

TI products are neither designed nor intended for use in automotive applications or environments unless the specific TI products are designated by TI as compliant with ISO/TS 16949 requirements. Buyers acknowledge and agree that, if they use any non-designated products in automotive applications, TI will not be responsible for any failure to meet such requirements.

Following are URLs where you can obtain information on other Texas Instruments products and application solutions:

### Products

Amplifiers	<a href="http://amplifier.ti.com">amplifier.ti.com</a>
Data Converters	<a href="http://dataconverter.ti.com">dataconverter.ti.com</a>
DSP	<a href="http://dsp.ti.com">dsp.ti.com</a>
Clocks and Timers	<a href="http://www.ti.com/clocks">www.ti.com/clocks</a>
Interface	<a href="http://interface.ti.com">interface.ti.com</a>
Logic	<a href="http://logic.ti.com">logic.ti.com</a>
Power Mgmt	<a href="http://power.ti.com">power.ti.com</a>
Microcontrollers	<a href="http://microcontroller.ti.com">microcontroller.ti.com</a>
RFID	<a href="http://www.ti-rfid.com">www.ti-rfid.com</a>
RF/IF and ZigBee® Solutions	<a href="http://www.ti.com/lprf">www.ti.com/lprf</a>

### Applications

Audio	<a href="http://www.ti.com/audio">www.ti.com/audio</a>
Automotive	<a href="http://www.ti.com/automotive">www.ti.com/automotive</a>
Broadband	<a href="http://www.ti.com/broadband">www.ti.com/broadband</a>
Digital Control	<a href="http://www.ti.com/digitalcontrol">www.ti.com/digitalcontrol</a>
Medical	<a href="http://www.ti.com/medical">www.ti.com/medical</a>
Military	<a href="http://www.ti.com/military">www.ti.com/military</a>
Optical Networking	<a href="http://www.ti.com/opticalnetwork">www.ti.com/opticalnetwork</a>
Security	<a href="http://www.ti.com/security">www.ti.com/security</a>
Telephony	<a href="http://www.ti.com/telephony">www.ti.com/telephony</a>
Video & Imaging	<a href="http://www.ti.com/video">www.ti.com/video</a>
Wireless	<a href="http://www.ti.com/wireless">www.ti.com/wireless</a>

Mailing Address: Texas Instruments, Post Office Box 655303, Dallas, Texas 75265  
Copyright © 2008, Texas Instruments Incorporated