

±1°C Remote and Local Temperature Sensor with η -Factor and Offset Correction, Series Resistance Cancellation, and Programmable Digital Filter

Check for Samples: [TMP451](#)

FEATURES

- ±1°C Accuracy for Local and Remote Diode Sensors
- 0.0625°C Resolution for Local and Remote Channels
- 1.7-V to 3.6-V Supply and Logic Voltage Range
- 27- μ A Operating Current, 3- μ A Shutdown Current
- Series Resistance Cancellation
- η -Factor and Offset Correction
- Programmable Digital Filter
- Diode Fault Detection
- Two-Wire and SMBus™ Serial Interface
- 8-Lead WSON (WDFN) Package

APPLICATIONS

- Processor/FPGA Temperature Monitoring
- Smartphones and Tablets
- Servers, Desktops, and Notebooks
- Telecom Equipment and Storage Area Networks (SAN)
- Automotive and Embedded Systems

DESCRIPTION

The TMP451 is a high-accuracy, low-power remote temperature sensor monitor with a built-in local temperature sensor. The remote temperature sensors are typically low-cost discrete NPN or PNP transistors, or substrate thermal transistors or diodes that are integral parts of microprocessors, microcontrollers, or FPGAs. The temperature is represented as a 12-bit digital code for both the local and the remote sensors, giving a resolution of 0.0625°C. The temperature accuracy is ±1°C (max) in the typical operating range for the local and the remote temperature sensors. The two-wire serial interface accepts the SMBus communication protocol.

Advanced features such as series resistance cancellation, programmable nonideality factor (η -factor), programmable offset, programmable temperature limits, and a programmable digital filter are combined to provide a robust thermal monitoring solution with improved accuracy and noise immunity.

The TMP451 is ideal for high-accuracy temperature measurements in a variety of consumer, computing, industrial, automotive, and communications systems. It is specified for operation over a supply voltage range of 1.7 V to 3.6 V and a temperature range of -40°C to +125°C.

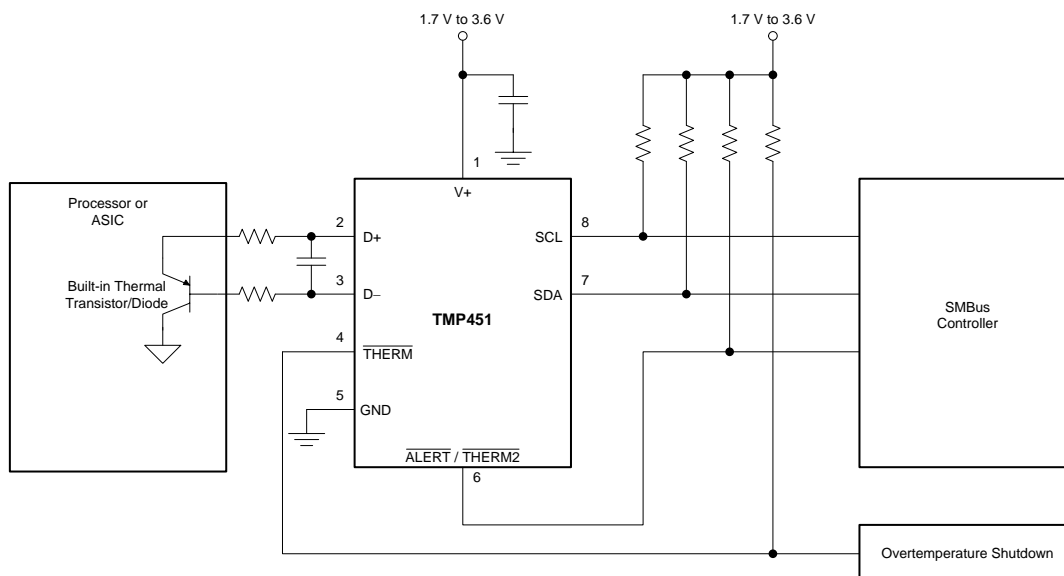

Please be aware that an important notice concerning availability, standard warranty, and use in critical applications of Texas Instruments semiconductor products and disclaimers thereto appears at the end of this data sheet.

SMBus is a trademark of Intel Corporation.

All other trademarks are the property of their respective owners.



This integrated circuit can be damaged by ESD. Texas Instruments recommends that all integrated circuits be handled with appropriate precautions. Failure to observe proper handling and installation procedures can cause damage.

ESD damage can range from subtle performance degradation to complete device failure. Precision integrated circuits may be more susceptible to damage because very small parametric changes could cause the device not to meet its published specifications.

PACKAGE AND ORDERING INFORMATION⁽¹⁾

PRODUCT	DESCRIPTION	TWO-WIRE ADDRESS
TMP451	Single Channel Remote Junction Temperature Sensor	1001 100

(1) For the most current package and ordering information see the Package Option Addendum at the end of this document, or see the TI web site at www.ti.com.

ABSOLUTE MAXIMUM RATINGS⁽¹⁾

Over operating free-air temperature range, unless otherwise noted.

	VALUE	UNIT
Power supply, V+	-0.3 to +3.6	V
Input voltage	Pins 4, 6, 7, and 8 only	-0.3 to +3.6
	Pin 2 only	-0.3 to (V+) + 0.3
	Pin 3 only	-0.3 to +0.3
Input current	10	mA
Operating temperature range	-55 to +127	°C
Storage temperature range	-60 to +150	°C
Junction temperature (T _J max)	+150	°C
Electrostatic discharge (ESD) ratings	Human body model (HBM)	3000
	Charged device model (CDM)	1000
	Machine model (MM)	200

(1) Stresses above these ratings may cause permanent damage. Exposure to absolute maximum conditions for extended periods may degrade device reliability. These are stress ratings only, and functional operation of the device at these or any other conditions beyond those specified is not implied.

THERMAL INFORMATION

THERMAL METRIC ⁽¹⁾		TMP451	UNITS
		DQF (DFN)	
		8 PINS	
θ_{JA}	Junction-to-ambient thermal resistance	171.3	°C/W
θ_{JCTop}	Junction-to-case (top) thermal resistance	81.4	
θ_{JB}	Junction-to-board thermal resistance	137.9	
ψ_{JT}	Junction-to-top characterization parameter	3.9	
ψ_{JB}	Junction-to-board characterization parameter	140	
θ_{JCbott}	Junction-to-case (bottom) thermal resistance	N/A	

(1) For more information about traditional and new thermal metrics, see the *IC Package Thermal Metrics* application report, [SPRA953](#).

ELECTRICAL CHARACTERISTICS

At $T_A = -40^\circ\text{C}$ to $+125^\circ\text{C}$ and $V_+ = 3.3\text{ V}$, unless otherwise noted.

PARAMETER		CONDITIONS	TMP451			UNIT
			MIN	TYP	MAX	
TEMPERATURE ERROR						
$T_{E\text{LOCAL}}$	Local temperature sensor	$T_A = 0^\circ\text{C}$ to $+70^\circ\text{C}$		± 0.25	± 1	$^\circ\text{C}$
		$T_A = -40^\circ\text{C}$ to $+125^\circ\text{C}$		± 1	± 2	$^\circ\text{C}$
$T_{E\text{REMOTE}}$	Remote temperature sensor ⁽¹⁾	$T_A = 0^\circ\text{C}$ to $+70^\circ\text{C}$, $T_D = -55^\circ\text{C}$ to $+150^\circ\text{C}$		± 0.25	± 1	$^\circ\text{C}$
		$T_A = -40^\circ\text{C}$ to $+100^\circ\text{C}$, $T_D = -55^\circ\text{C}$ to $+150^\circ\text{C}$		± 1	± 2	$^\circ\text{C}$
		$T_A = -40^\circ\text{C}$ to $+125^\circ\text{C}$, $T_D = -55^\circ\text{C}$ to $+150^\circ\text{C}$		± 2	± 4	$^\circ\text{C}$
vs Supply (local or remote)		$V_+ = 1.7\text{ V}$ to 3.6 V		± 0.1	± 0.25	$^\circ\text{C}/\text{V}$
TEMPERATURE MEASUREMENT						
Conversion time		One-Shot mode, local and remote total		31	34	ms
Resolution	Local temperature sensor			12		Bits
	Remote temperature sensor			12		Bits
Remote sensor source currents	High	Series resistance $1\text{ k}\Omega$ max		120		μA
	Medium			45		μA
	Low			7.5		μA
η	Remote transistor ideality factor	TMP451 optimized ideality factor		1.008		
SMBus INTERFACE						
V_{IH}	High-level input voltage		1.4			V
V_{IL}	Low-level input voltage				0.45	V
Hysteresis				200		mV
SMBus output low sink current			6			mA
V_{OL}	Low-level output voltage	$I_{OUT} = 6\text{ mA}$		0.15	0.4	V
Logic input current		$0\text{ V} \leq V_{IN} \leq 3.6\text{ V}$		-1	+1	μA
SMBus input capacitance				3		pF
SMBus clock frequency			0.01		2.5	MHz
SMBus timeout			20	25	30	ms
SCL falling edge to SDA valid time					1	μs
DIGITAL OUTPUTS (THERM, ALERT/THERM2)						
V_{OL}	Low-level output voltage	$I_{OUT} = 6\text{ mA}$		0.15	0.4	V
I_{OH}	High-level output leakage current	$V_{OUT} = V_+$			1	μA
POWER SUPPLY						
V_+	Specified voltage range		1.7		3.6	V
I_Q	Quiescent current	0.0625 conversions per second		27	40	μA
		16 conversions per second		165	250	μA
		32 conversions per second		300	450	μA
		Serial bus inactive, shutdown mode		3	8	μA
		Serial bus active, $f_S = 400\text{ kHz}$, shutdown mode		90		μA
		Serial bus active, $f_S = 2.5\text{ MHz}$, shutdown mode		350		μA
POR	Power-on reset threshold			1.2	1.55	V

(1) Tested with less than $5\text{-}\Omega$ effective series resistance and 100-pF differential input capacitance.

PIN CONFIGURATION

**DQF PACKAGE
WSO8-8 (DFN-8)
(TOP VIEW)**

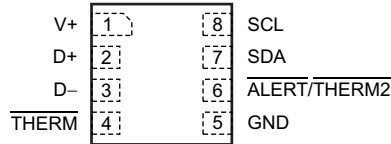

PIN ASSIGNMENTS

TMP451		DESCRIPTION
NAME	NO.	
$\overline{\text{ALERT}} / \text{THERM2}$	6	Interrupt or SMBus alert output. Can be configured as a second $\overline{\text{THERM}}$ output. Open-drain; requires pull-up resistor to voltage between 1.7 V and 3.6 V.
D-	3	Negative connection to remote temperature sensor.
D+	2	Positive connection to remote temperature sensor.
GND	5	Supply ground connection.
SCL	8	Serial clock line for SMBus. Input; requires pull-up resistor to voltage between 1.7 V and 3.6 V if driven by open-drain output.
SDA	7	Serial data line for SMBus. Open-drain; requires pull-up resistor to voltage between 1.7 V and 3.6 V.
$\overline{\text{THERM}}$	4	Thermal shutdown or fan-control pin. Open-drain; requires pull-up resistor to voltage between 1.7 V and 3.6 V.
V+	1	Positive supply voltage, 1.7 V to 3.6 V.

TYPICAL CHARACTERISTICS

At $T_A = +25^\circ\text{C}$ and $V_+ = +3.3\text{ V}$, unless otherwise noted.

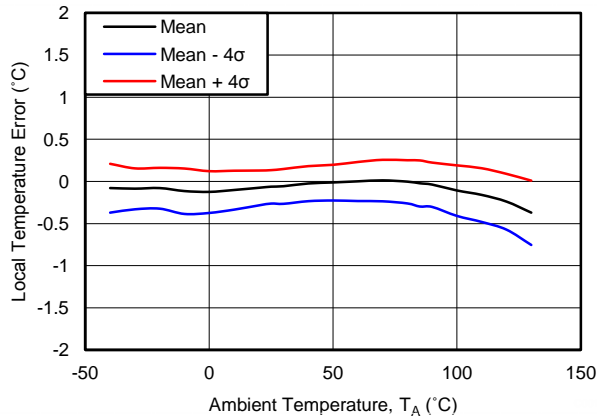

Figure 1. LOCAL TEMPERATURE ERROR vs TEMPERATURE

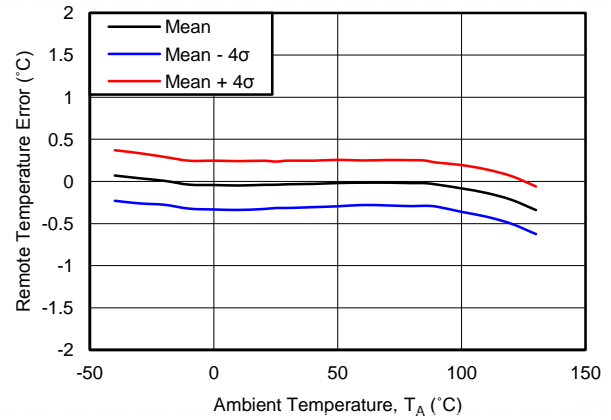

Figure 2. REMOTE TEMPERATURE ERROR vs TEMPERATURE

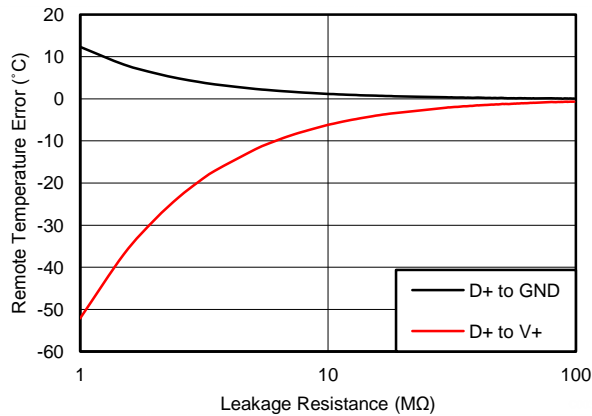

Figure 3. REMOTE TEMPERATURE ERROR vs LEAKAGE RESISTANCE

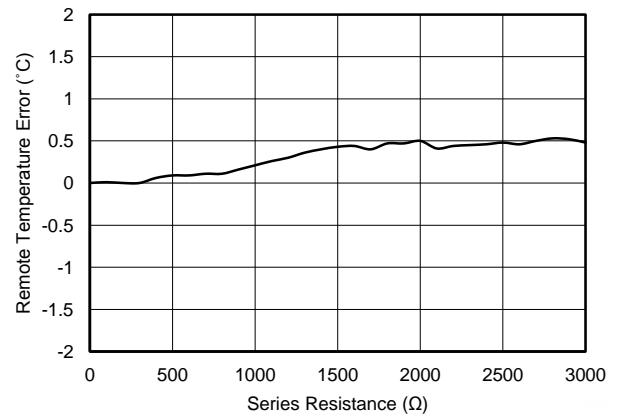

Figure 4. REMOTE TEMPERATURE ERROR vs SERIES RESISTANCE

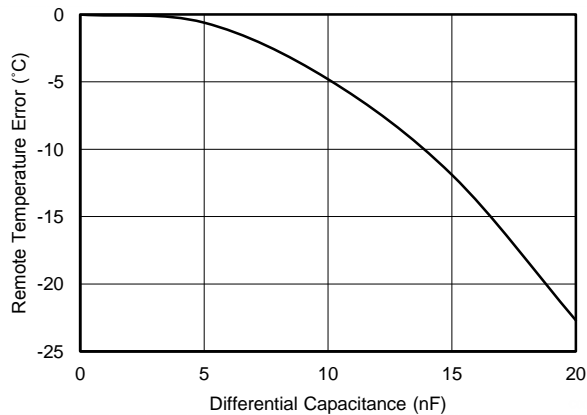

Figure 5. REMOTE TEMPERATURE ERROR vs DIFFERENTIAL CAPACITANCE

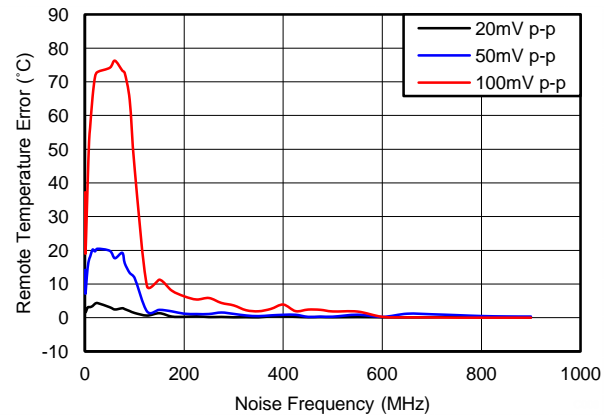

Figure 6. REMOTE TEMPERATURE ERROR vs REMOTE CHANNEL NOISE FREQUENCY

TYPICAL CHARACTERISTICS (continued)

At $T_A = +25^\circ\text{C}$ and $V_+ = +3.3\text{ V}$, unless otherwise noted.

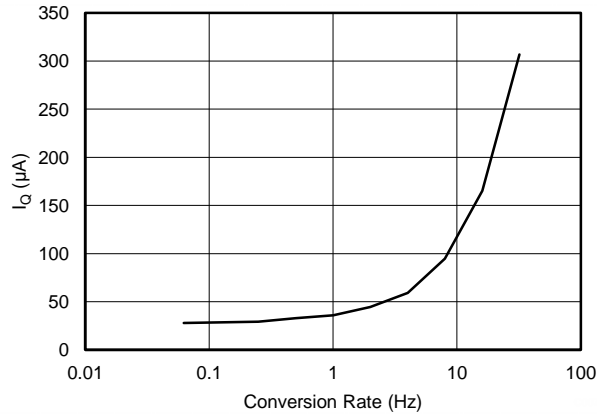

Figure 7. QUIESCENT CURRENT vs CONVERSION RATE

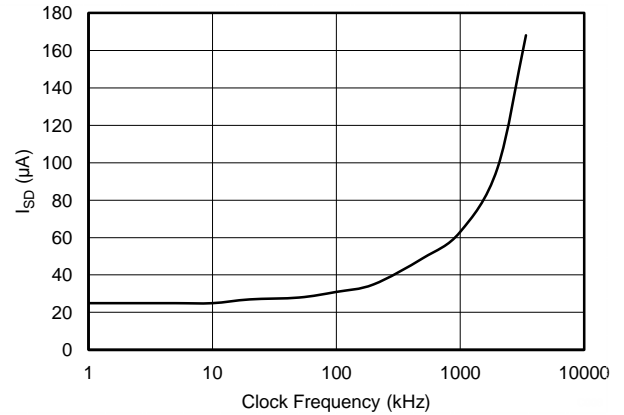

Figure 8. SHUTDOWN QUIESCENT CURRENT vs SCL CLOCK FREQUENCY

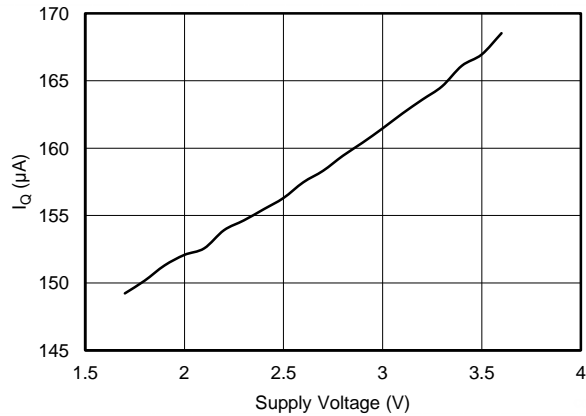

Figure 9. QUIESCENT CURRENT vs SUPPLY VOLTAGE (At Default Conversion Rate of 16 Conversions per Second)

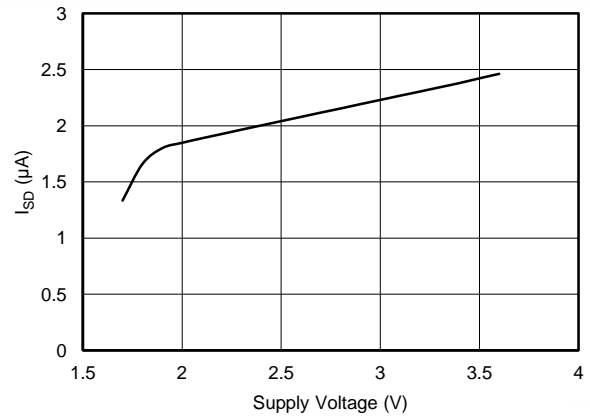
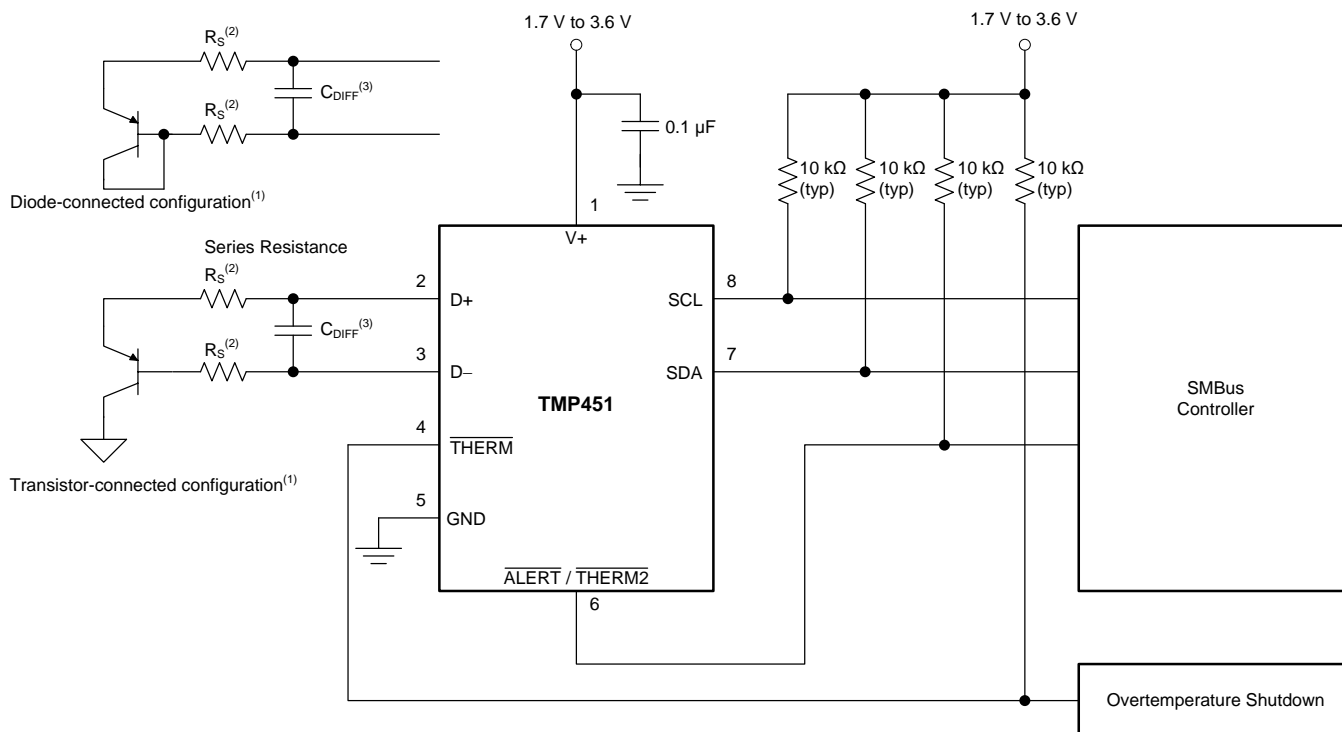

Figure 10. SHUTDOWN QUIESCENT CURRENT vs SUPPLY VOLTAGE

APPLICATION INFORMATION

The TMP451 is a digital temperature sensor that combines a local temperature measurement channel and a remote-junction temperature measurement channel in a single DFN-8 package. The device is two-wire- and SMBus-interface compatible, and is specified over a temperature range of -40°C to $+125^{\circ}\text{C}$. The TMP451 also contains multiple registers for programming and holding configuration settings, temperature limits, and temperature measurement results.

The TMP451 requires only a transistor connected between the D+ and D– pins for remote temperature measurement. Tie the D+ pin to GND if the remote channel is not used and only the local temperature is measured. The SDA, ALERT, and THERM pins (and SCL, if driven by an open-drain output) require pull-up resistors as part of the communication bus. A $0.1\text{-}\mu\text{F}$ power-supply decoupling capacitor is recommended for local bypassing. Figure 11 shows the typical configuration for the TMP451.



(1) Diode-connected configuration provides better settling time. Transistor-connected configuration provides better series resistance cancellation.

(2) R_S (optional) should be $< 1\text{ k}\Omega$ in most applications. Selection of R_S depends on application; see the [Filtering](#) section.

(3) C_{DIFF} (optional) should be $< 1000\text{ pF}$ in most applications. Selection of C_{DIFF} depends on application; see the [Filtering](#) section and [Figure 5, Remote Temperature Error vs Differential Capacitance](#).

Figure 11. TMP451 Basic Connections

SERIES RESISTANCE CANCELLATION

Series resistance cancellation automatically eliminates the temperature error caused by the resistance of the routing to the remote transistor or by the resistors of the optional external low-pass filter. A total of up to 1 kΩ of series resistance can be cancelled by the TMP451, eliminating the need for additional characterization and temperature offset correction. See [Figure 4, Remote Temperature Error vs Series Resistance](#), for details on the effects of series resistance on sensed remote temperature error.

DIFFERENTIAL INPUT CAPACITANCE

The TMP451 tolerates differential input capacitance of up to 1000 pF with minimal change in temperature error. The effect of capacitance on sensed remote temperature error is illustrated in [Figure 5, Remote Temperature Error vs Differential Capacitance](#).

TEMPERATURE MEASUREMENT DATA

The local and remote temperature sensors have a resolution of 12 bits (0.0625°C). Temperature data that result from conversions within the default measurement range are represented in binary form, as shown in the *Standard Binary* column of [Table 1](#). Any temperature below 0°C results in a data value of 0 (00h). Likewise, temperatures above +127°C result in a value of 127 (7Fh). The device can be set to measure over an extended temperature range by changing bit 2 (RANGE) of configuration register from low to high. The change in measurement range and data format from standard binary to extended binary occurs at the next temperature conversion. For data captured in the extended temperature range configuration, an offset of 64 (40h) is added to the standard binary value, as shown in the *Extended Binary* column of [Table 1](#). This configuration allows measurement of temperatures as low as –64°C, and as high as +191°C; however, most temperature-sensing diodes only measure with the range of –55°C to +150°C. Additionally, the TMP451 is specified only for ambient temperatures ranging from –40°C to +125°C; parameters in the [Absolute Maximum Ratings](#) table must be observed.

Table 1. Temperature Data Format (Local and Remote Temperature High Bytes)

TEMPERATURE (°C)	LOCAL/REMOTE TEMPERATURE REGISTER HIGH BYTE VALUE (1°C RESOLUTION)			
	STANDARD BINARY ⁽¹⁾		EXTENDED BINARY ⁽²⁾	
	BINARY	HEX	BINARY	HEX
–64	0000 0000	00	0000 0000	00
–50	0000 0000	00	0000 1110	0E
–25	0000 0000	00	0010 0111	27
0	0000 0000	00	0100 0000	40
1	0000 0001	01	0100 0001	41
5	0000 0101	05	0100 0101	45
10	0000 1010	0A	0100 1010	4A
25	0001 1001	19	0101 1001	59
50	0011 0010	32	0111 0010	72
75	0100 1011	4B	1000 1011	8B
100	0110 0100	64	1010 0100	A4
125	0111 1101	7D	1011 1101	BD
127	0111 1111	7F	1011 1111	BF
150	0111 1111	7F	1101 0110	D6
175	0111 1111	7F	1110 1111	EF
191	0111 1111	7F	1111 1111	FF

(1) Resolution is 1°C/count. Negative numbers are represented in twos complement format.

(2) Resolution is 1°C/count. All values are unsigned with a –64°C offset.

Both local and remote temperature data use two bytes for data storage. The high byte stores the temperature with 1°C resolution. The second or low byte stores the decimal fraction value of the temperature and allows a higher measurement resolution, as shown in Table 2. The measurement resolution for both the local and the remote channels is 0.0625°C.

Table 2. Decimal Fraction Temperature Data Format (Local and Remote Temperature Low Bytes)

TEMP (°C)	TEMPERATURE REGISTER LOW BYTE VALUE (0.0625°C RESOLUTION)(1)	
	STANDARD AND EXTENDED BINARY	HEX
0	0000 0000	00
0.0625	0001 0000	10
0.1250	0010 0000	20
0.1875	0011 0000	30
0.2500	0100 0000	40
0.3125	0101 0000	50
0.3750	0110 0000	60
0.4375	0111 0000	70
0.5000	1000 0000	80
0.5625	1001 0000	90
0.6250	1010 0000	A0
0.6875	1011 0000	B0
0.7500	1100 0000	C0
0.8125	1101 0000	D0
0.8750	1110 0000	E0
0.9385	1111 0000	F0

(1) Resolution is 0.0625°C/count. All possible values are shown.

Standard Binary to Decimal Temperature Data Calculation Example

High-byte conversion (for example, 0111 0011):

Convert the right-justified binary high byte to hexadecimal.

From hexadecimal, multiply the first number by $16^0 = 1$ and the second number by $16^1 = 16$.

The sum equals the decimal equivalent.

$$0111\ 0011b \rightarrow 73h \rightarrow (3 \times 16^0) + (7 \times 16^1) = 115$$

Low-byte conversion (for example, 0111 0000):

To convert the left-justified binary low-byte to decimal, use bits 7 through 4 and ignore bits 3 through 0 because they do not affect the value of the number.

$$0111b \rightarrow (0 \times 1/2)^1 + (1 \times 1/2)^2 + (1 \times 1/2)^3 + (1 \times 1/2)^4 = 0.4375$$

Standard Decimal to Binary Temperature Data Calculation Example

For positive temperatures (for example, +20°C):

$$(+20^\circ\text{C}) / (+1^\circ\text{C}/\text{count}) = 20 \rightarrow 14h \rightarrow 0001\ 0100$$

Convert the number to binary code with 8-bit, right-justified format, and MSB = '0' to denote a positive sign.

+20°C is stored as 0001 0100 → 14h.

For negative temperatures (for example, –20°C):

$$(|-20|) / (+1^\circ\text{C}/\text{count}) = 20 \rightarrow 14h \rightarrow 0001\ 0100$$

Generate the two's complement of a negative number by complementing the absolute value binary number and adding 1.

–20°C is stored as 1110 1100 → ECh.

REGISTER INFORMATION

The TMP451 contains multiple registers for holding configuration information, temperature measurement results, and status information. These registers are described in [Figure 12](#) and [Table 3](#).

Pointer Register

[Figure 12](#) shows the internal register structure of the TMP451. The 8-bit pointer register is used to address a given data register. The pointer register identifies which of the data registers should respond to a read or write command on the two-wire bus. This register is set with every write command. A write command must be issued to set the proper value in the pointer register before executing a read command. [Table 3](#) describes the pointer register and the internal structure of the TMP451 registers. The power-on reset (POR) value of the pointer register is 00h (0000 0000b).

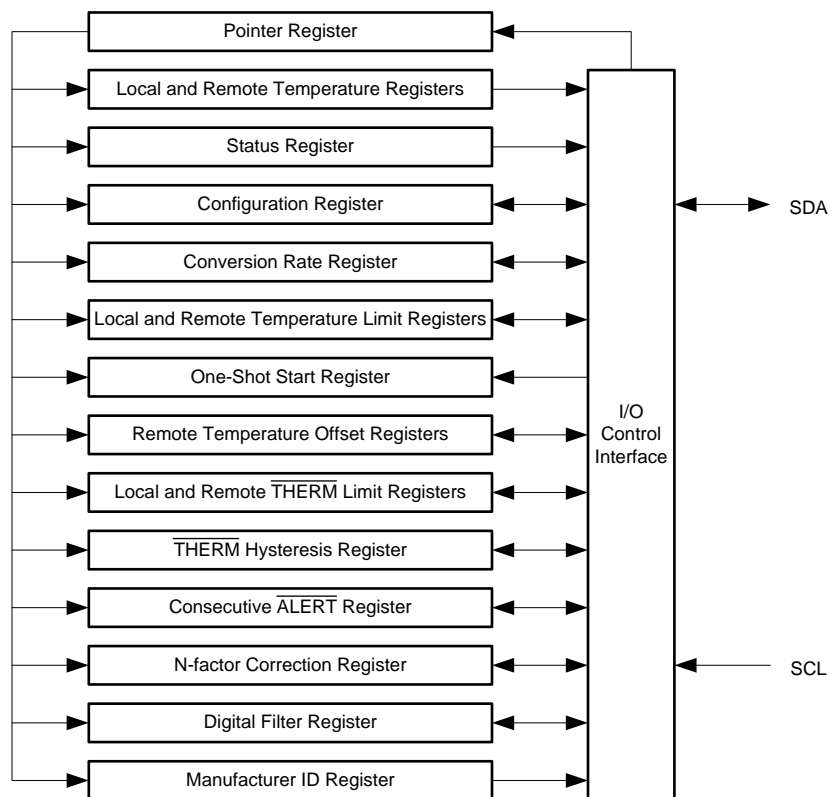

Figure 12. Internal Register Structure

Table 3. Register Map

POINTER READ (HEX)	POINTER WRITE (HEX)	POR (HEX)	BIT DESCRIPTION								REGISTER DESCRIPTION
			7	6	5	4	3	2	1	0	
00	N/A	00	LT11	LT10	LT9	LT8	LT7	LT6	LT5	LT4	Local temperature (high byte)
01	N/A	00	RT11	RT10	RT9	RT8	RT7	RT6	RT5	RT4	Remote temperature (high byte)
02	N/A	N/A	BUSY	LHIGH	LLOW	RHIGH	RLOW	OPEN	RTHRM	LTHRM	status register
03	09	00	MASK1	SD	ALERT/ THERM2	0	0	RANGE	0	0	configuration register
04	0A	08	0	0	0	0	CR3	CR2	CR1	CR0	Conversion rate register
05	0B	55	LTHL11	LTHL10	LTHL9	LTHL8	LTHL7	LTHL6	LTHL5	LTHL4	Local temperature high limit
06	0C	00	LTL11	LTL10	LTL9	LTL8	LTL7	LTL6	LTL5	LTL4	Local temperature low limit
07	0D	55	RTHL11	RTHL10	RTHL9	RTHL8	RTHL7	RTHL6	RTHL5	RTHL4	Remote temperature high limit (high byte)
08	0E	00	RTL11	RTL10	RTL9	RTL8	RTL7	RTL6	RTL5	RTL4	Remote temperature low limit (high byte)
N/A	0F	N/A	X	X	X	X	X	X	X	X	One-shot start ⁽¹⁾
10	N/A	00	RT3	RT2	RT1	RT0	0	0	0	0	Remote temperature (low byte)
11	11	00	RTOS11	RTOS10	RTOS9	RTOS8	RTOS7	RTOS6	RTOS5	RTOS4	Remote temperature offset (high byte)
12	12	00	RTOS3	RTOS2	RTOS1	RTOS0	0	0	0	0	Remote temperature offset (low byte)
13	13	00	RTHL3	RTHL2	RTHL1	RTHL0	0	0	0	0	Remote temperature high limit (low byte)
14	14	00	RTL3	RTL2	RTL1	RTL0	0	0	0	0	Remote temperature low limit (low byte)
15	N/A	00	LT3	LT2	LT1	LT0	0	0	0	0	Local temperature (low byte)
19	19	6C	RTH11	RTH10	RTH9	RTH8	RTH7	RTH6	RTH5	RTH4	Remote temperature THERM limit
20	20	55	LTH11	LTH10	LTH9	LTH8	LTH7	LTH6	LTH5	LTH4	Local temperature THERM limit
21	21	0A	HYS11	HYS10	HYS9	HYS8	HYS7	HYS6	HYS5	HYS4	THERM hysteresis
22	22	01	SMBTO	0	0	0	CONAL2	CONAL1	CONAL0	0	Consecutive ALERT
23	23	00	NC7	NC6	NC5	NC4	NC3	NC2	NC1	NC0	η-factor correction
24	24	00	0	0	0	0	0	0	DF1	DF0	Digital filter control
FE	N/A	55	0	1	0	1	0	1	0	1	Manufacturer ID

(1) X = undefined. Writing any value to this register initiates a one-shot start; see the [One-Shot Conversion](#) section.

Temperature Registers

The TMP451 has multiple 8-bit registers that hold temperature measurement results. The eight most significant bits (MSBs) of the local temperature sensor result are stored in register 00h, while the four least significant bits (LSBs) are stored in register 15h (the four MSBs of register 15h). The eight MSBs of the remote temperature sensor result are stored in register 01h, and the four LSBs are stored in register 10h (the four MSBs of register 10h). The four LSBs of both the local sensor and the remote sensor indicate the temperature value after the decimal point (for example, if the temperature result is 10.0625°C, the high byte is 0000 1010 and the low byte is 0001 0000). These registers are read-only and are updated by the ADC each time a temperature measurement is completed.

When the full temperature value is needed, reading the MSB value first causes the LSB value to be locked (the ADC does not write to it) until it is read. The same thing happens upon reading the LSB value first (the MSB value is locked until it is read). This mechanism assures that both bytes of the read operation are from the same ADC conversion. This assurance remains valid only until another register is read. For proper operation, read the high byte of the temperature result first. Read the low byte register in the next read command; if the LSBs are not needed, the register may be left unread. The power-on reset value of all temperature registers is 00h.

Status Register

The status register reports the state of the temperature ADC, the temperature limit comparators, and the connection to the remote sensor. Table 4 summarizes the status register bits. The status register is read-only, and is read by accessing pointer address 02h.

Table 4. Status Register Format

STATUS REGISTER (READ = 02h, WRITE = N/A)		
BIT NUMBER	BIT NAME	FUNCTION
7	BUSY	= '1' when the ADC is converting
6	LHIGH ⁽¹⁾	= '1' when the local high temperature limit is tripped
5	LLOW ⁽¹⁾	= '1' when the local low temperature limit is tripped
4	RHIGH ⁽¹⁾	= '1' when the remote high temperature limit is tripped
3	RLOW ⁽¹⁾	= '1' when the remote low temperature limit is tripped
2	OPEN ⁽¹⁾	= '1' when the remote sensor is an open circuit
1	RTHRM	= '1' when the remote $\overline{\text{THERM}}$ limit is tripped
0	LTHRM	= '1' when the local $\overline{\text{THERM}}$ limit is tripped

- (1) These flags stay high until the status register is read or they are reset by a POR when pin 6 is configured as $\overline{\text{ALERT}}$. Only bit 2 ($\overline{\text{OPEN}}$) stays high until the status register is read or it is reset by a POR when pin 6 is configured as $\overline{\text{THERM2}}$.

The BUSY bit = '1' if the ADC is making a conversion; it is set to '0' if the ADC is not converting.

The LHIGH and LLOW bits indicate a local sensor overtemperature or undertemperature event, respectively. The RHIGH and RLOW bits indicate a remote sensor overtemperature or undertemperature event, respectively. The OPEN bit indicates an open circuit condition on the remote sensor. When pin 6 is configured as the $\overline{\text{ALERT}}$ output, the five flags are NORed together. If any of the five flags are high, the $\overline{\text{ALERT}}$ interrupt latch is set and the $\overline{\text{ALERT}}$ output goes low. Reading the status register clears the five flags, provided that the condition that caused the setting of the flags is not present anymore (that is, the value of the corresponding result register is within the limits, or the remote sensor is connected properly and functional). The $\overline{\text{ALERT}}$ interrupt latch (and the $\overline{\text{ALERT}}$ pin correspondingly) is not reset by reading the status register. The reset is done by the master reading the temperature sensor device address to service the interrupt, and only if the flags have been reset and the condition that caused them to be set is not present.

The RTHRM and LTHRM flags are set when the corresponding temperature exceeds the programmed $\overline{\text{THERM}}$ limit. They are reset automatically when the temperature returns to within the limits. The $\overline{\text{THERM}}$ output goes low in the case of overtemperature on either the local or the remote channel, and goes high as soon as the measurements are within the limits again. The $\overline{\text{THERM}}$ Hysteresis register (21h) allows hysteresis to be added so that the flag resets and the output goes high when the temperature returns to or goes below the limit value minus the hysteresis value.

When pin 6 is configured as $\overline{\text{THERM2}}$, only the high limits matter. The LHIGH and RHIGH flags are set if the respective temperatures exceed the limit values, and the pin goes low to indicate the event. The LLOW and RLOW flags have no effect on $\overline{\text{THERM2}}$, and the output behaves the same way as $\overline{\text{THERM}}$.

Configuration Register

configuration register sets the temperature range, the $\overline{\text{ALERT}}/\overline{\text{THERM}}$ modes, and controls the shutdown mode. The configuration register is set by writing to pointer address 09h, and read by reading from pointer address 03h. [Table 5](#) summarizes the bits of configuration register.

Table 5. Configuration Register Bit Descriptions

CONFIGURATION REGISTER (READ = 03h, WRITE = 09h, POR = 00h)			
BIT NUMBER	NAME	FUNCTION	POWER-ON RESET VALUE
7	MASK1	0 = $\overline{\text{ALERT}}$ Enabled 1 = $\overline{\text{ALERT}}$ Masked	0
6	SD	0 = Run 1 = Shut down	0
5	$\overline{\text{ALERT}}/\overline{\text{THERM2}}$	0 = $\overline{\text{ALERT}}$ 1 = $\overline{\text{THERM2}}$	0
4:3	Reserved	—	0
2	RANGE	0 = 0°C to +127°C 1 = -64°C to +191°C	0
1:0	Reserved	—	0

MASK1 (bit 7) of the configuration register masks the $\overline{\text{ALERT}}$ output. If MASK1 is '0' (default), the $\overline{\text{ALERT}}$ output is enabled. If MASK1 is set to '1', the $\overline{\text{ALERT}}$ output is disabled. This configuration applies only if the value of $\overline{\text{ALERT}}/\overline{\text{THERM2}}$ (bit 5) is '0' (that is, pin 6 is configured as the $\overline{\text{ALERT}}$ output). If pin 6 is configured as the $\overline{\text{THERM2}}$ output, the value of the MASK1 bit has no effect.

The shutdown bit (SD, bit 6) enables or disables the temperature-measurement circuitry. If SD = '0' (default), the TMP451 converts continuously at the rate set in the conversion rate register. When SD is set to '1', the TMP451 stops converting when the current conversion sequence is complete and enters a shutdown mode. When SD is set to '0' again, the TMP451 resumes continuous conversions. When SD = '1', a single conversion can be started by writing to the one-shot start register. See the [One-Shot Conversion](#) section for more information.

$\overline{\text{ALERT}}/\overline{\text{THERM2}}$ (bit 5) sets the configuration of pin 6. If the $\overline{\text{ALERT}}/\overline{\text{THERM2}}$ bit is '0' (default), then pin 6 is configured as the $\overline{\text{ALERT}}$ output; if it is set to '1', then pin 6 is configured as the $\overline{\text{THERM2}}$ output.

The temperature range is set by configuring RANGE (bit 2) of the configuration register. Setting this bit low (default) configures the TMP451 for the standard measurement range (0°C to +127°C); temperature conversions are stored in the standard binary format. Setting bit 2 high configures the TMP451 for the extended measurement range (-64°C to +191°C); temperature conversions are stored in the extended binary format (see [Table 1](#)).

The remaining bits of the configuration register are reserved and must always be set to '0'. The power-on reset value for this register is 00h.

Conversion Rate Register

The conversion rate register (read address 04h, write address 0Ah) controls the rate at which temperature conversions are performed. This register adjusts the idle time between conversions but not the conversion time itself, thereby allowing the TMP451 power dissipation to be balanced with the temperature register update rate. [Table 6](#) describes the conversion rate options and corresponding time between conversions. The default value of the register is 08h, which gives a default rate of 16 conversions per second.

Table 6. Conversion Rate Register

CONVERSION RATE REGISTER (READ = 04h, WRITE = 0Ah, POR = 08h)		
VALUE	CONVERSIONS PER SECOND	TIME (SECONDS)
00h	0.0625	16
01h	0.125	8
02h	0.25	4
03h	0.5	2
04h	1	1
05h	2	0.5
06h	4	0.25
07h	8	0.125
08h	16 (default)	0.0625 (default)
09h	32	0.03125

One-Shot Start Register

When the TMP451 is in shutdown mode (SD = '1' in the configuration register), a single conversion is started by writing any value to the one-shot start register, pointer address 0Fh. This write operation starts one conversion and comparison cycle on both the local and the remote sensors. The TMP41 returns to shutdown mode when the cycle completes. The value of the data sent in the write command is irrelevant and is not stored by the TMP451.

η-Factor Correction Register

The TMP451 allows for a different η-factor value to be used for converting remote channel measurements to temperature. The remote channel uses sequential current excitation to extract a differential V_{BE} voltage measurement to determine the temperature of the remote transistor. Equation 1 describes this voltage and temperature.

$$V_{BE2} - V_{BE1} = \frac{\eta kT}{q} \ln \left(\frac{I_2}{I_1} \right) \quad (1)$$

The value η in Equation 1 is a characteristic of the particular transistor used for the remote channel. The power-on reset value for the TMP451 is η = 1.008. The value in the η-factor correction register may be used to adjust the effective η-factor according to Equation 2 and Equation 3.

$$\eta_{\text{eff}} = \left(\frac{1.008 \times 2088}{2088 + N_{\text{ADJUST}}} \right) \quad (2)$$

$$N_{\text{ADJUST}} = \left(\frac{1.008 \times 2088}{\eta_{\text{eff}}} \right) - 2088 \quad (3)$$

The η-factor correction value must be stored in twos complement format, yielding an effective data range from –128 to +127. The η-factor correction value is written to and read from pointer address 23h. The register power-on reset value is 00h, thus having no effect unless a different value is written to it.

Table 7. η-Factor Range

N _{ADJUST}			η
BINARY	HEX	DECIMAL	
0111 1111	7F	127	0.950198
0000 1010	0A	10	1.003195
0000 1000	08	8	1.004152
0000 0110	06	6	1.005111
0000 0100	04	4	1.006072
0000 0010	02	2	1.007035
0000 0001	01	1	1.007517
0000 0000	00	0	1.008
1111 1111	FF	–1	1.008483
1111 1110	FE	–2	1.008967
1111 1100	FC	–4	1.009935
1111 1010	FA	–6	1.010905
1111 1000	F8	–8	1.011877
1111 0110	F6	–10	1.012851
1000 0000	80	–128	1.073837

Offset Register

The offset register allows the TMP451 to store any system offset compensation value that might be observed from precision calibration. The value in the register is stored in the same format as the temperature result, and is added to the remote temperature result upon every conversion. Combined with the η-factor correction, this function allows for very accurate system calibration over the entire temperature range.

ALERT and THERM Functions

The operation of the $\overline{\text{ALERT}}$ (pin 6) and $\overline{\text{THERM}}$ (pin 4) interrupts is shown in Figure 13. The operation of the THERM (pin 4) and THERM2 (pin 6) interrupts is shown in Figure 14.

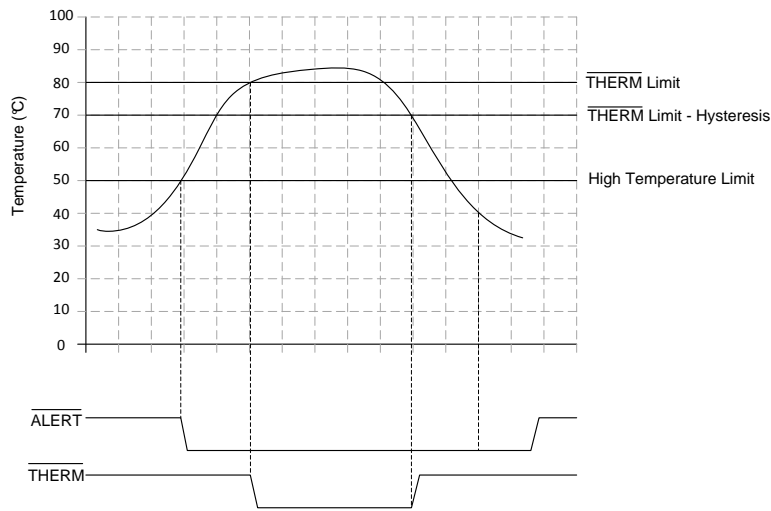

Figure 13. $\overline{\text{ALERT}}$ and $\overline{\text{THERM}}$ Interrupt Operation

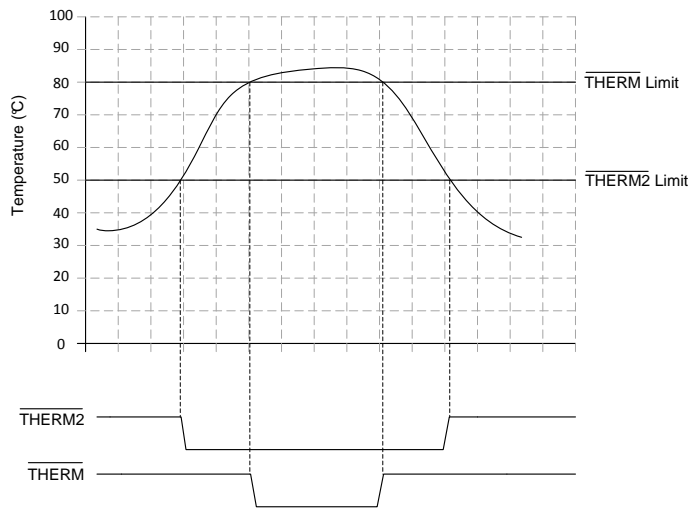

Figure 14. $\overline{\text{THERM}}$ and $\overline{\text{THERM2}}$ Interrupt Operation

The hysteresis value can be stored in the $\overline{\text{THERM}}$ hysteresis register.

General Call Reset

The TMP451 supports reset using the two-wire General Call address 00h (0000 0000b). The TMP451 acknowledges the General Call address and responds to the second byte. If the second byte is 06h (0000 0110b), the TMP451 execute a software reset. This software reset restores the power-on reset state to all TMP451 registers, and it aborts any conversion in progress. The TMP451 takes no action in response to other values in the second byte.

Identification Register

The TMP451 allows for the two-wire bus controller to query the device for manufacturer and device IDs to enable software identification of the device at the particular two-wire bus address. The manufacturer ID is obtained by reading from pointer address FEh. The TMP451 reads 55h for the manufacturer code.

BUS OVERVIEW

The TMP451 is SMBus interface compatible. In SMBus protocol, the device that initiates the transfer is called a *master*, and the devices controlled by the master are *slaves*. The bus must be controlled by a master device that generates the serial clock (SCL), controls the bus access, and generates the start and stop conditions.

To address a specific device, a start condition is initiated. A start condition is indicated by pulling the data line (SDA) from a high-to-low logic level while SCL is high. All slaves on the bus shift in the slave address byte, with the last bit indicating whether a read or write operation is intended. During the ninth clock pulse, the slave being addressed responds to the master by generating an *acknowledge* bit and pulling SDA low.

Data transfer is then initiated and sent over eight clock pulses followed by an acknowledge bit. During data transfer SDA must remain stable while SCL is high, because any change in SDA while SCL is high is interpreted as a control signal.

After all data have been transferred, the master generates a stop condition. A stop condition is indicated by pulling SDA from low to high, while SCL is high.

SERIAL INTERFACE

The TMP451 operates only as a slave device on either the two-wire bus or the SMBus. Connections to either bus are made using the open-drain I/O lines, SDA and SCL. The SDA and SCL pins feature integrated spike suppression filters and Schmitt triggers to minimize the effects of input spikes and bus noise. The TMP451 supports the transmission protocol for fast (1 kHz to 400 kHz) and high-speed (1 kHz to 2.5 MHz) modes. All data bytes are transmitted MSB first.

SERIAL BUS ADDRESS

To communicate with the TMP451, the master must first address slave devices using a slave address byte. The slave address byte consists of seven address bits, and a direction bit indicating the intent of executing a read or write operation. The TMP451 has a device address of 4Ch (1001 100b). Additional factory-programmed device addresses are available upon request.

READ/WRITE OPERATIONS

Accessing a particular register on the TMP451 is accomplished by writing the appropriate value to the pointer register. The value for the pointer register is the first byte transferred after the slave address byte with the R/W bit low. Every write operation to the TMP451 requires a value for the pointer register (see [Figure 16](#)).

When reading from the TMP451, the last value stored in the pointer register by a write operation is used to determine which register is read by a read operation. To change which register is read for a read operation, a new value must be written to the pointer register. This transaction is accomplished by issuing a slave address byte with the R/W bit low, followed by the pointer register byte; no additional data are required. The master can then generate a start condition and send the slave address byte with the R/W bit high to initiate the read command; see [Figure 17](#) for details of this sequence.

If repeated reads from the same register are desired, it is not necessary to continually send the pointer register bytes, because the TMP451 retains the pointer register value until it is changed by the next write operation. Note that register bytes are sent MSB first, followed by the LSB.

Read operations should be terminated by issuing a *not-acknowledge* command at the end of the last byte to be read. For single-byte operation, the master must leave the SDA line high during the acknowledge time of the first byte that is read from the slave.

TIMING DIAGRAMS

The TMP451 is two-wire and SMBus-compatible. Figure 15 to Figure 17 describe the timing for various operations on the TMP451. Parameters for Figure 15 are defined in Table 8. Bus definitions are:

Bus Idle: Both SDA and SCL lines remain high.

Start Data Transfer: A change in the state of the SDA line, from high to low, while the SCL line is high, defines a start condition. Each data transfer initiates with a start condition. Denoted as S in Figure 15.

Stop Data Transfer: A change in the state of the SDA line from low to high while the SCL line is high defines a stop condition. Each data transfer terminates with a repeated start or stop condition. Denoted as P in Figure 15.

Data Transfer: The number of data bytes transferred between a start and a stop condition is not limited and is determined by the master device. The receiver acknowledges data transfer.

Acknowledge: Each receiving device, when addressed, is obliged to generate an acknowledge bit. A device that acknowledges must pull down the SDA line during the acknowledge clock pulse in such a way that the SDA line is stable low during the high period of the acknowledge clock pulse. Take setup and hold times into account. On a master receive, data transfer termination can be signaled by the master generating a not-acknowledge on the last byte that has been transmitted by the slave.

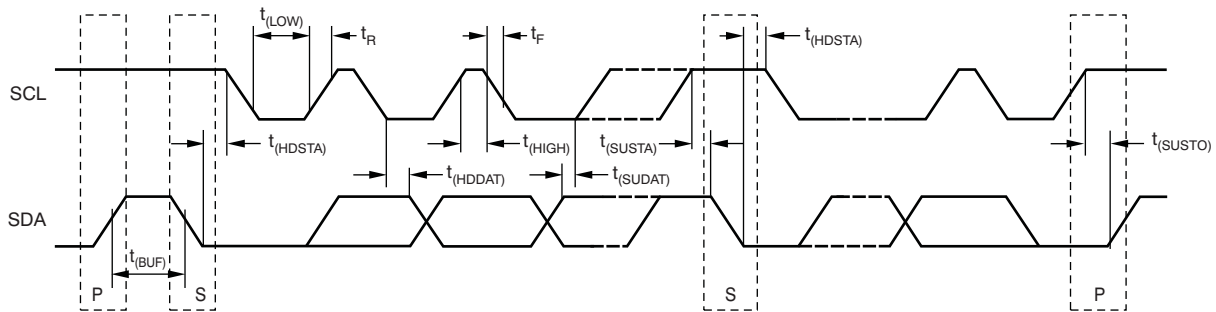
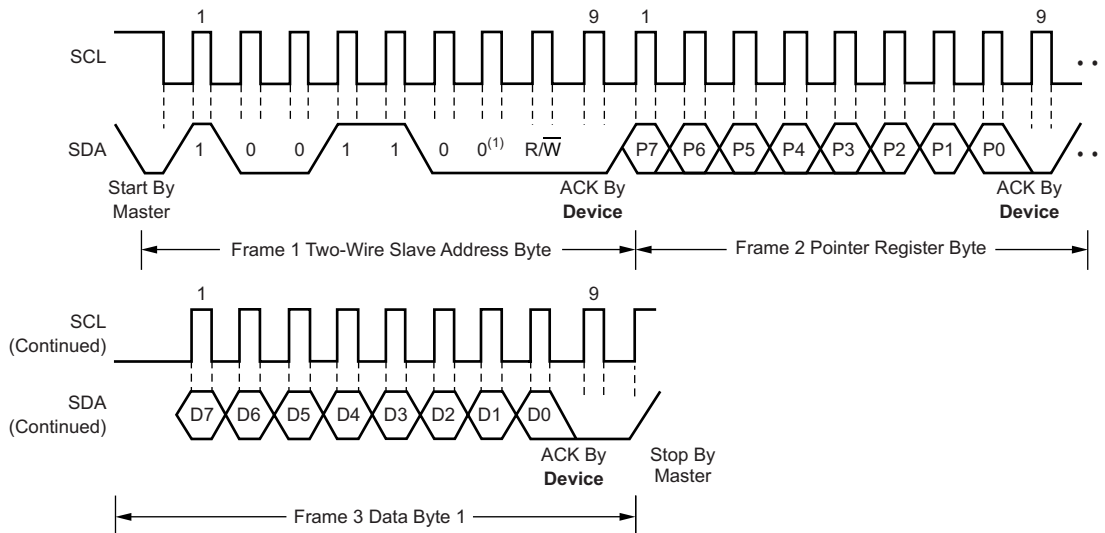

Figure 15. Two-Wire Timing Diagram

Table 8. Timing Characteristics for Figure 15

PARAMETER		FAST MODE		HIGH-SPEED MODE		UNIT
		MIN	MAX	MIN	MAX	
SCL Operating Frequency	$f_{(SCL)}$	0.001	0.4	0.001	2.5	MHz
Bus Free Time Between STOP and START Condition	$t_{(BUF)}$	1300		260		ns
Hold time after repeated START condition. After this period, the first clock is generated.	$t_{(HDSTA)}$	600		160		ns
Repeated START Condition Setup Time	$t_{(SUSTA)}$	600		160		ns
STOP Condition Setup Time	$t_{(SUSTO)}$	600		160		ns
Data Hold Time	$t_{(HDDAT)}$	0	900	0	150	ns
Data Setup Time	$t_{(SUDAT)}$	100		30		ns
SCL Clock LOW Period	$t_{(LOW)}$	1300		260		ns
SCL Clock HIGH Period	$t_{(HIGH)}$	600		60		ns
Data Fall/Rise Time	$t_{F, t_{R}}$ - SDA		300		80	ns
Clock Fall/Rise Time	$t_{F, t_{R}}$ - SCL		300		40	ns
for SCL \leq 100kHz	t_{R}		1000			ns



(1) Slave address 1001100 shown.

Figure 16. Two-Wire Timing Diagram for Write Word Format

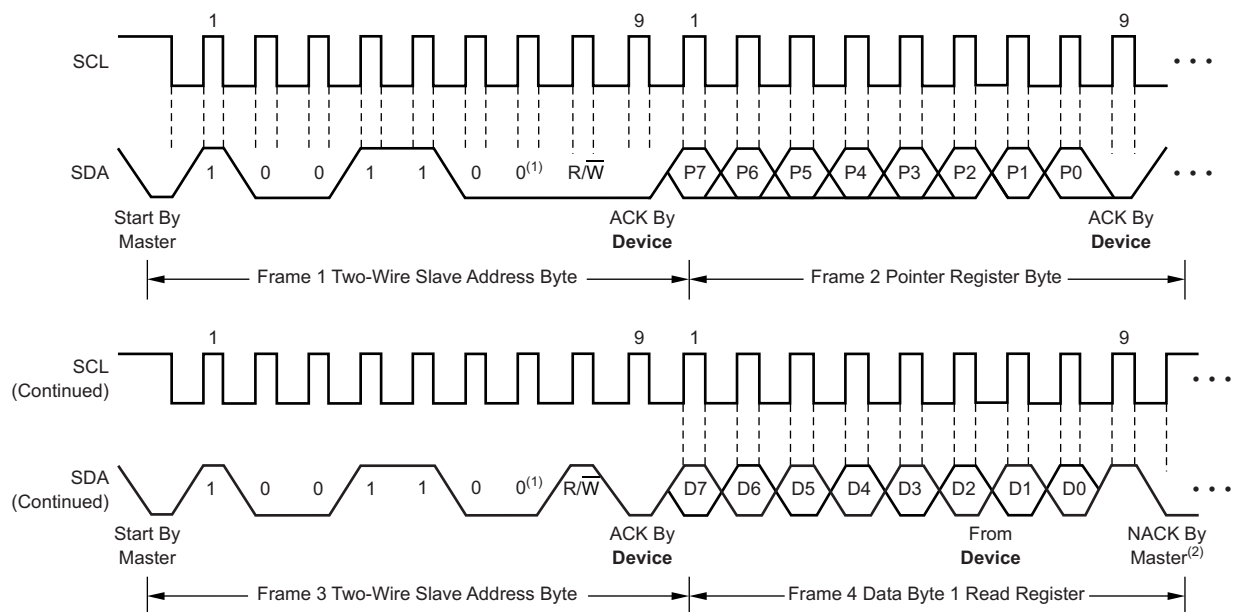

(1) Slave address 1001100 shown.

(2) Master should leave SDA high to terminate a single-byte read operation.

Figure 17. Two-Wire Timing Diagram for Single-Byte Read Format

HIGH-SPEED MODE

In order for the two-wire bus to operate at frequencies above 400 kHz, the master device must issue a high-speed mode (Hs-mode) master code (0000 1xxx) as the first byte after a start condition to switch the bus to high-speed operation. The TMP451 does not acknowledge this byte, but switches the input filters on SDA and SCL and the output filter on SDA to operate in HS-mode, allowing transfers at up to 2.5 MHz. After the Hs-mode master code has been issued, the master transmits a two-wire slave address to initiate a data transfer operation. The bus continues to operate in Hs-mode until a stop condition occurs on the bus. Upon receiving the stop condition, the TMP451 switches the input and output filters back to fast mode operation.

TIMEOUT FUNCTION

The TMP451 resets the serial interface if either SCL or SDA are held low for 25 ms (typical) between a start and stop condition. If the TMP451 is holding the bus low, the device releases the bus and waits for a start condition. To avoid activating the timeout function, it is necessary to maintain a communication speed of at least 1 kHz for the SCL operating frequency.

SHUTDOWN MODE (SD)

The TMP451 shutdown mode enables the user to save maximum power by shutting down all device circuitry other than the serial interface, reducing current consumption to typically less than 3 μ A; see [Figure 10](#), *Shutdown Quiescent Current vs Supply Voltage*. Shutdown mode is enabled when SD (bit 6) of configuration register is high; the device shuts down after the current conversion is finished. When SD is low, the device maintains a continuous-conversion state.

SENSOR FAULT

The TMP451 can sense a fault at the D+ input resulting from incorrect diode connection. The TMP451 can also sense an open circuit. Short-circuit conditions return a value of -64°C . The detection circuitry consists of a voltage comparator that trips when the voltage at D+ exceeds $(V+) - 0.3\text{ V}$ (typical). The comparator output is continuously checked during a conversion. If a fault is detected, then OPEN (bit 2) in the status register is set to '1'.

When not using the remote sensor with the TMP451, the D+ and D- inputs must be connected together to prevent meaningless fault warnings.

FILTERING

Remote junction temperature sensors are usually implemented in a noisy environment. Noise is most often created by fast digital signals, and it can corrupt measurements. The TMP451 has a built-in, 65-kHz filter on the inputs of D+ and D- to minimize the effects of noise. However, a bypass capacitor placed differentially across the inputs of the remote temperature sensor is recommended to make the application more robust against unwanted coupled signals. For this capacitor, choose a value of between 100 pF and 1 nF. Some applications attain better overall accuracy with additional series resistance; however, this increased accuracy is application-specific. When series resistance is added, the total value should not be greater than 1 k Ω . If filtering is required, suggested component values are 100 pF and 50 Ω on each input; exact values are application-specific.

Additionally, a digital filter is available for the remote temperature measurements to further reduce the effect of noise. This filter is programmable and has two levels when enabled. Level 1 performs a moving average of four consecutive samples. Level 2 performs a moving average of eight consecutive samples. The value stored in the remote temperature result register is the output of the digital filter, and the $\overline{\text{ALERT}}$ and $\overline{\text{THERM}}$ limits are compared to it. This provides additional immunity to noise and spikes on the $\overline{\text{ALERT}}$ and $\overline{\text{THERM}}$ outputs. The filter responses are shown in [Figure 18](#). The filter can be enabled or disabled by programming the desired levels in the digital filter register. The digital filter is disabled by default and on POR.

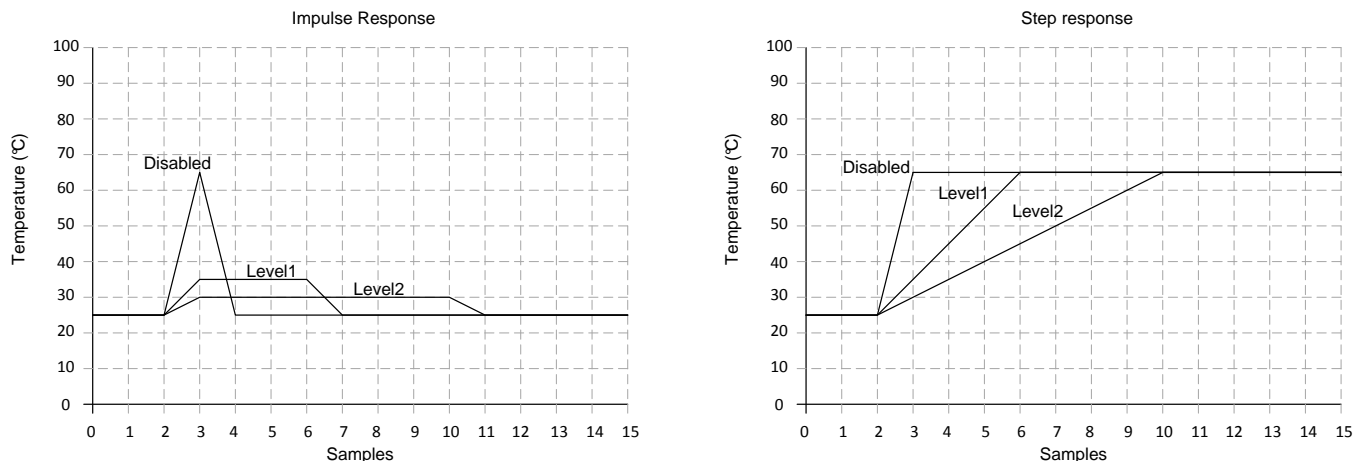

Figure 18. Filter Response to Impulse and Step Inputs

REMOTE SENSING

The TMP451 is designed to be used with either discrete transistors or substrate transistors built into processor chips and ASICs. Either NPN or PNP transistors can be used, as long as the base-emitter junction is used as the remote temperature sense. NPN transistors must be diode-connected. PNP transistors can either be transistor- or diode-connected (see [Figure 11](#)).

Errors in remote temperature sensor readings are typically the consequence of the ideality factor and current excitation used by the TMP451 versus the manufacturer-specified operating current for a given transistor. Some manufacturers specify a high-level and low-level current for the temperature-sensing substrate transistors. The TMP451 uses 7.5 μA for I_{LOW} and 120 μA for I_{HIGH} .

The ideality factor (η) is a measured characteristic of a remote temperature sensor diode as compared to an ideal diode. The TMP451 allows for different η -factor values; see the [\$\eta\$ -Factor Correction Register](#) section.

The ideality factor for the TMP451 is trimmed to be 1.008. For transistors that have an ideality factor that does not match the TMP451, [Equation 4](#) can be used to calculate the temperature error. Note that for the equation to be used correctly, actual temperature ($^{\circ}\text{C}$) must be converted to kelvins (K).

$$T_{\text{ERR}} = \left(\frac{\eta - 1.008}{1.008} \right) \times (273.15 + T(^{\circ}\text{C})) \quad (4)$$

Where:

η = ideality factor of remote temperature sensor

$T(^{\circ}\text{C})$ = actual temperature

T_{ERR} = error in TMP451 because $\eta \neq 1.008$

Degree delta is the same for $^{\circ}\text{C}$ and K.

For $\eta = 1.004$ and $T(^{\circ}\text{C}) = 100^{\circ}\text{C}$:

$$T_{\text{ERR}} = \left(\frac{1.004 - 1.008}{1.008} \right) \times (273.15 + 100^{\circ}\text{C})$$

$$T_{\text{ERR}} = 1.48^{\circ}\text{C} \quad (5)$$

If a discrete transistor is used as the remote temperature sensor with the TMP451, the best accuracy can be achieved by selecting the transistor according to the following criteria:

1. Base-emitter voltage $> 0.25\text{ V}$ at 7.5 μA , at the highest sensed temperature.
2. Base-emitter voltage $< 0.95\text{ V}$ at 120 μA , at the lowest sensed temperature.
3. Base resistance $< 100\ \Omega$.
4. Tight control of V_{BE} characteristics indicated by small variations in h_{FE} (that is, 50 to 150).

Based on these criteria, two recommended small-signal transistors are the 2N3904 (NPN) or 2N3906 (PNP).

MEASUREMENT ACCURACY AND THERMAL CONSIDERATIONS

The temperature measurement accuracy of the TMP451 depends on the remote and/or local temperature sensor being at the same temperature as the system point being monitored. Clearly, if the temperature sensor is not in good thermal contact with the part of the system being monitored, then there will be a delay in the response of the sensor to a temperature change in the system. For remote temperature-sensing applications using a substrate transistor (or a small, SOT23 transistor) placed close to the device being monitored, this delay is usually not a concern.

The local temperature sensor inside the TMP451 monitors the ambient air around the device. The thermal time constant for the TMP451 is approximately two seconds. This constant implies that if the ambient air changes quickly by 100°C , it would take the TMP451 about 10 seconds (that is, five thermal time constants) to settle to within 1°C of the final value. In most applications, the TMP451 package is in electrical, and therefore thermal, contact with the printed circuit board (PCB), as well as subjected to forced airflow. The accuracy of the measured temperature directly depends on how accurately the PCB and forced airflow temperatures represent the

temperature that the TMP451 is measuring. Additionally, the internal power dissipation of the TMP451 can cause the temperature to rise above the ambient or PCB temperature. The internal power dissipated as a result of exciting the remote temperature sensor is negligible because of the small currents used. For a 3.3-V supply and maximum conversion rate of 16 conversions per second, the TMP451 dissipate 0.54 mW ($PD_{IQ} = 3.3\text{ V} \times 165\text{ }\mu\text{A}$). A θ_{JA} of 171.3°C/W causes the junction temperature to rise approximately +0.09°C above the ambient.

LAYOUT CONSIDERATIONS

Remote temperature sensing on the TMP451 measures very small voltages using very low currents; therefore, noise at the device inputs must be minimized. Most applications using the TMP451 have high digital content, with several clocks and logic level transitions creating a noisy environment. Layout should adhere to the following guidelines:

1. Place the TMP451 as close to the remote junction sensor as possible.
2. Route the D+ and D– traces next to each other and shield them from adjacent signals through the use of ground guard traces; see Figure 19. If a multilayer PCB is used, bury these traces between ground or V+ planes to shield them from extrinsic noise sources. 5 mil (0.127 mm) PCB traces are recommended.
3. Minimize additional thermocouple junctions caused by copper-to-solder connections. If these junctions are used, make the same number and approximate locations of copper-to-solder connections in both the D+ and D– connections to cancel any thermocouple effects.
4. Use a 0.1μF local bypass capacitor directly between the V+ and GND of the TMP451. For optimum measurement performance, minimize filter capacitance between D+ and D– to 1000 pF or less . This capacitance includes any cable capacitance between the remote temperature sensor and the TMP451.
5. If the connection between the remote temperature sensor and the TMP451 is less than 8 in (20.32 cm) long, use a twisted-wire pair connection. For lengths greater than 8 in, use a twisted, shielded pair with the shield grounded as close to the TMP451 as possible. Leave the remote sensor connection end of the shield wire open to avoid ground loops and 60-Hz pickup.
6. Thoroughly clean and remove all flux residue in and around the pins of the TMP451 to avoid temperature offset readings as a result of leakage paths between D+ and GND, or between D+ and V+.

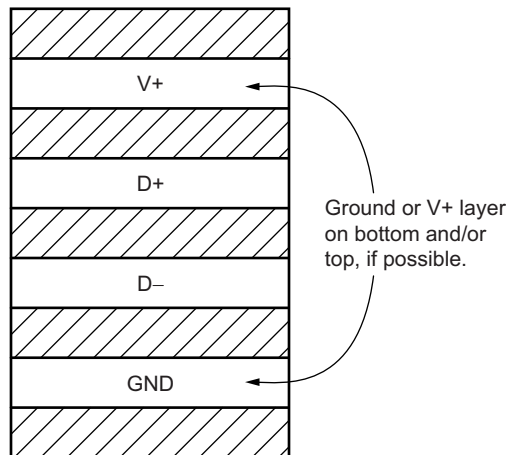

NOTE: Use minimum 5 mil (0.127 mm) traces with 5 mil spacing.

Figure 19. Suggested PCB Layer Cross-Section

PACKAGING INFORMATION

Orderable Device	Status (1)	Package Type	Package Drawing	Pins	Package Qty	Eco Plan (2)	Lead/Ball Finish	MSL Peak Temp (3)	Op Temp (°C)	Device Marking (4/5)	Samples
TMP451AIDQFR	PREVIEW	WSON	DQF	8	3000	Green (RoHS & no Sb/Br)	CU NIPDAU	Level-1-260C-UNLIM	-40 to 125	T451	
TMP451AIDQFT	PREVIEW	WSON	DQF	8	250	Green (RoHS & no Sb/Br)	CU NIPDAU	Level-1-260C-UNLIM	-40 to 125	T451	

(1) The marketing status values are defined as follows:

ACTIVE: Product device recommended for new designs.

LIFEBUY: TI has announced that the device will be discontinued, and a lifetime-buy period is in effect.

NRND: Not recommended for new designs. Device is in production to support existing customers, but TI does not recommend using this part in a new design.

PREVIEW: Device has been announced but is not in production. Samples may or may not be available.

OBSOLETE: TI has discontinued the production of the device.

(2) Eco Plan - The planned eco-friendly classification: Pb-Free (RoHS), Pb-Free (RoHS Exempt), or Green (RoHS & no Sb/Br) - please check <http://www.ti.com/productcontent> for the latest availability information and additional product content details.

TBD: The Pb-Free/Green conversion plan has not been defined.

Pb-Free (RoHS): TI's terms "Lead-Free" or "Pb-Free" mean semiconductor products that are compatible with the current RoHS requirements for all 6 substances, including the requirement that lead not exceed 0.1% by weight in homogeneous materials. Where designed to be soldered at high temperatures, TI Pb-Free products are suitable for use in specified lead-free processes.

Pb-Free (RoHS Exempt): This component has a RoHS exemption for either 1) lead-based flip-chip solder bumps used between the die and package, or 2) lead-based die adhesive used between the die and leadframe. The component is otherwise considered Pb-Free (RoHS compatible) as defined above.

Green (RoHS & no Sb/Br): TI defines "Green" to mean Pb-Free (RoHS compatible), and free of Bromine (Br) and Antimony (Sb) based flame retardants (Br or Sb do not exceed 0.1% by weight in homogeneous material)

(3) MSL, Peak Temp. -- The Moisture Sensitivity Level rating according to the JEDEC industry standard classifications, and peak solder temperature.

(4) There may be additional marking, which relates to the logo, the lot trace code information, or the environmental category on the device.

(5) Multiple Device Markings will be inside parentheses. Only one Device Marking contained in parentheses and separated by a "~" will appear on a device. If a line is indented then it is a continuation of the previous line and the two combined represent the entire Device Marking for that device.

Important Information and Disclaimer: The information provided on this page represents TI's knowledge and belief as of the date that it is provided. TI bases its knowledge and belief on information provided by third parties, and makes no representation or warranty as to the accuracy of such information. Efforts are underway to better integrate information from third parties. TI has taken and continues to take reasonable steps to provide representative and accurate information but may not have conducted destructive testing or chemical analysis on incoming materials and chemicals. TI and TI suppliers consider certain information to be proprietary, and thus CAS numbers and other limited information may not be available for release.

In no event shall TI's liability arising out of such information exceed the total purchase price of the TI part(s) at issue in this document sold by TI to Customer on an annual basis.

TAPE AND REEL INFORMATION



QUADRANT ASSIGNMENTS FOR PIN 1 ORIENTATION IN TAPE



*All dimensions are nominal

Device	Package Type	Package Drawing	Pins	SPQ	Reel Diameter (mm)	Reel Width W1 (mm)	A0 (mm)	B0 (mm)	K0 (mm)	P1 (mm)	W (mm)	Pin1 Quadrant
TMP451AIDQFR	WSO	DQF	8	3000	179.0	8.4	2.2	2.2	1.2	4.0	8.0	Q2
TMP451AIDQFT	WSO	DQF	8	250	179.0	8.4	2.2	2.2	1.2	4.0	8.0	Q2

TAPE AND REEL BOX DIMENSIONS



*All dimensions are nominal

Device	Package Type	Package Drawing	Pins	SPQ	Length (mm)	Width (mm)	Height (mm)
TMP451AIDQFR	WSON	DQF	8	3000	203.0	203.0	35.0
TMP451AIDQFT	WSON	DQF	8	250	203.0	203.0	35.0

IMPORTANT NOTICE

Texas Instruments Incorporated and its subsidiaries (TI) reserve the right to make corrections, enhancements, improvements and other changes to its semiconductor products and services per JESD46, latest issue, and to discontinue any product or service per JESD48, latest issue. Buyers should obtain the latest relevant information before placing orders and should verify that such information is current and complete. All semiconductor products (also referred to herein as "components") are sold subject to TI's terms and conditions of sale supplied at the time of order acknowledgment.

TI warrants performance of its components to the specifications applicable at the time of sale, in accordance with the warranty in TI's terms and conditions of sale of semiconductor products. Testing and other quality control techniques are used to the extent TI deems necessary to support this warranty. Except where mandated by applicable law, testing of all parameters of each component is not necessarily performed.

TI assumes no liability for applications assistance or the design of Buyers' products. Buyers are responsible for their products and applications using TI components. To minimize the risks associated with Buyers' products and applications, Buyers should provide adequate design and operating safeguards.

TI does not warrant or represent that any license, either express or implied, is granted under any patent right, copyright, mask work right, or other intellectual property right relating to any combination, machine, or process in which TI components or services are used. Information published by TI regarding third-party products or services does not constitute a license to use such products or services or a warranty or endorsement thereof. Use of such information may require a license from a third party under the patents or other intellectual property of the third party, or a license from TI under the patents or other intellectual property of TI.

Reproduction of significant portions of TI information in TI data books or data sheets is permissible only if reproduction is without alteration and is accompanied by all associated warranties, conditions, limitations, and notices. TI is not responsible or liable for such altered documentation. Information of third parties may be subject to additional restrictions.

Resale of TI components or services with statements different from or beyond the parameters stated by TI for that component or service voids all express and any implied warranties for the associated TI component or service and is an unfair and deceptive business practice. TI is not responsible or liable for any such statements.

Buyer acknowledges and agrees that it is solely responsible for compliance with all legal, regulatory and safety-related requirements concerning its products, and any use of TI components in its applications, notwithstanding any applications-related information or support that may be provided by TI. Buyer represents and agrees that it has all the necessary expertise to create and implement safeguards which anticipate dangerous consequences of failures, monitor failures and their consequences, lessen the likelihood of failures that might cause harm and take appropriate remedial actions. Buyer will fully indemnify TI and its representatives against any damages arising out of the use of any TI components in safety-critical applications.

In some cases, TI components may be promoted specifically to facilitate safety-related applications. With such components, TI's goal is to help enable customers to design and create their own end-product solutions that meet applicable functional safety standards and requirements. Nonetheless, such components are subject to these terms.

No TI components are authorized for use in FDA Class III (or similar life-critical medical equipment) unless authorized officers of the parties have executed a special agreement specifically governing such use.

Only those TI components which TI has specifically designated as military grade or "enhanced plastic" are designed and intended for use in military/aerospace applications or environments. Buyer acknowledges and agrees that any military or aerospace use of TI components which have **not** been so designated is solely at the Buyer's risk, and that Buyer is solely responsible for compliance with all legal and regulatory requirements in connection with such use.

TI has specifically designated certain components as meeting ISO/TS16949 requirements, mainly for automotive use. In any case of use of non-designated products, TI will not be responsible for any failure to meet ISO/TS16949.

Products

Audio	www.ti.com/audio
Amplifiers	amplifier.ti.com
Data Converters	dataconverter.ti.com
DLP® Products	www.dlp.com
DSP	dsp.ti.com
Clocks and Timers	www.ti.com/clocks
Interface	interface.ti.com
Logic	logic.ti.com
Power Mgmt	power.ti.com
Microcontrollers	microcontroller.ti.com
RFID	www.ti-rfid.com
OMAP Applications Processors	www.ti.com/omap
Wireless Connectivity	www.ti.com/wirelessconnectivity

Applications

Automotive and Transportation	www.ti.com/automotive
Communications and Telecom	www.ti.com/communications
Computers and Peripherals	www.ti.com/computers
Consumer Electronics	www.ti.com/consumer-apps
Energy and Lighting	www.ti.com/energy
Industrial	www.ti.com/industrial
Medical	www.ti.com/medical
Security	www.ti.com/security
Space, Avionics and Defense	www.ti.com/space-avionics-defense
Video and Imaging	www.ti.com/video

TI E2E Community

e2e.ti.com