

1.8V, Nanopower, PUSH-PULL OUTPUT COMPARATOR

FEATURES

- VERY LOW SUPPLY CURRENT: 0.8 μ A (typ)
- INPUT COMMON-MODE RANGE 200mV BEYOND SUPPLY RAILS
- SUPPLY VOLTAGE: +1.8V to +5.5V
- HIGH SPEED: 6 μ s
- PUSH-PULL CMOS OUTPUT STAGE
- SMALL PACKAGES:
SOT23-5 (Single)
SOT23-8 (Dual)

APPLICATIONS

- PORTABLE MEDICAL EQUIPMENT
- WIRELESS SECURITY SYSTEMS
- REMOTE CONTROL SYSTEMS
- HANDHELD INSTRUMENTS
- ULTRA-LOW POWER SYSTEMS

DESCRIPTION

The TLV349x family of push-pull output comparators features a fast 6 μ s response time and < 1.2 μ A (max) nanopower capability, allowing operation from 1.8V – 5.5V. Input common-mode range beyond supply rails make the TLV349x an ideal choice for low-voltage applications.

Micro-sized packages provide options for portable and space-restricted applications. The single (TLV3491) is available in SOT23-5 and SO-8. The dual (TLV3492) comes in SOT23-8 and SO-8. The quad (TLV3494) is available in TSSOP-14 and SO-14.

The TLV349x is excellent for power-sensitive, low-voltage (2-cell) applications.

TLV349x RELATED PRODUCTS

PRODUCT	FEATURES
TLV370x	560nA, 2.5V to 16V, Push-Pull CMOS Output Stage Comparator
TLV340x	550nA, 2.5V to 16V, Open Drain Output Stage Comparator



Please be aware that an important notice concerning availability, standard warranty, and use in critical applications of Texas Instruments semiconductor products and disclaimers thereto appears at the end of this data sheet.

All trademarks are the property of their respective owners.

ABSOLUTE MAXIMUM RATINGS⁽¹⁾

Supply Voltage	+5.5V
Signal Input Terminals, Voltage ⁽²⁾	(V-) - 0.5V to (V+) + 0.5V
Current ⁽²⁾	±10mA
Output Short-Circuit ⁽³⁾	Continuous
Operating Temperature	-40°C to +125°C
Storage Temperature	-65°C to +150°C
Junction Temperature	+150°C
Lead Temperature (soldering, 10s)	+300°C
ESD Rating (Human Body Model)	3000V

NOTE: (1) Stresses above these ratings may cause permanent damage. Exposure to absolute maximum conditions for extended periods may degrade device reliability. These are stress ratings only, and functional operation of the device at these or any other conditions beyond those specified is not implied. (2) Input terminals are diode-clamped to the power-supply rails. Input signals that can swing more than 0.5V beyond the supply rails should be current limited to 10mA or less. (3) Short-circuit to ground, one amplifier per package.



ELECTROSTATIC DISCHARGE SENSITIVITY

This integrated circuit can be damaged by ESD. Texas Instruments recommends that all integrated circuits be handled with appropriate precautions. Failure to observe proper handling and installation procedures can cause damage.

ESD damage can range from subtle performance degradation to complete device failure. Precision integrated circuits may be more susceptible to damage because very small parametric changes could cause the device not to meet its published specifications.

PACKAGE/ORDERING INFORMATION⁽¹⁾

PRODUCT	PACKAGE-LEAD	PACKAGE DESIGNATOR	SPECIFIED TEMPERATURE RANGE	PACKAGE MARKING	ORDERING NUMBER	TRANSPORT MEDIA, QUANTITY
TLV3491	SOT23-5	DBV	-40°C to +125°C	VBNI	TLV3491AIDBVT	Tube, 250
"	"	"	"	"	TLV3491AIDBVR	Tape and Reel, 3000
TLV3491	SO-8	D	-40°C to +125°C	TLV3491	TLV3491AID	Tube, 100
"	"	"	"	"	TLV3491AIDR	Tube, 2500
TLV3492	SOT23-8	DCN	-40°C to +125°C	VBO1	TLV3492AIDCNT	Tube, 250
"	"	"	"	"	TLV3492AIDCNR	Tape and Reel, 3000
TLV3492	SO-8	D	-40°C to +125°C	TLV3492	TLV3492AID	Tube, 100
"	"	"	"	"	TLV3492AIDR	Tape and Reel, 2500
TLV3494	TSSOP-14	PW	-40°C to +125°C	TLV3494	TLV3494AIPWT	Tape and Reel, 94
"	"	"	"	"	TLV3494AIPWR	Tape and Reel, 2500
TLV3494	SO-14	D	-40°C to +125°C	TLV3494	TLV3494AID	Tape and Reel, 58
"	"	"	"	"	TLV3494AIDR	Tape and Reel, 2500

NOTE: (1) For the most current package and ordering information, see the Package Option Addendum located at the end of this data sheet.

PIN CONFIGURATIONS

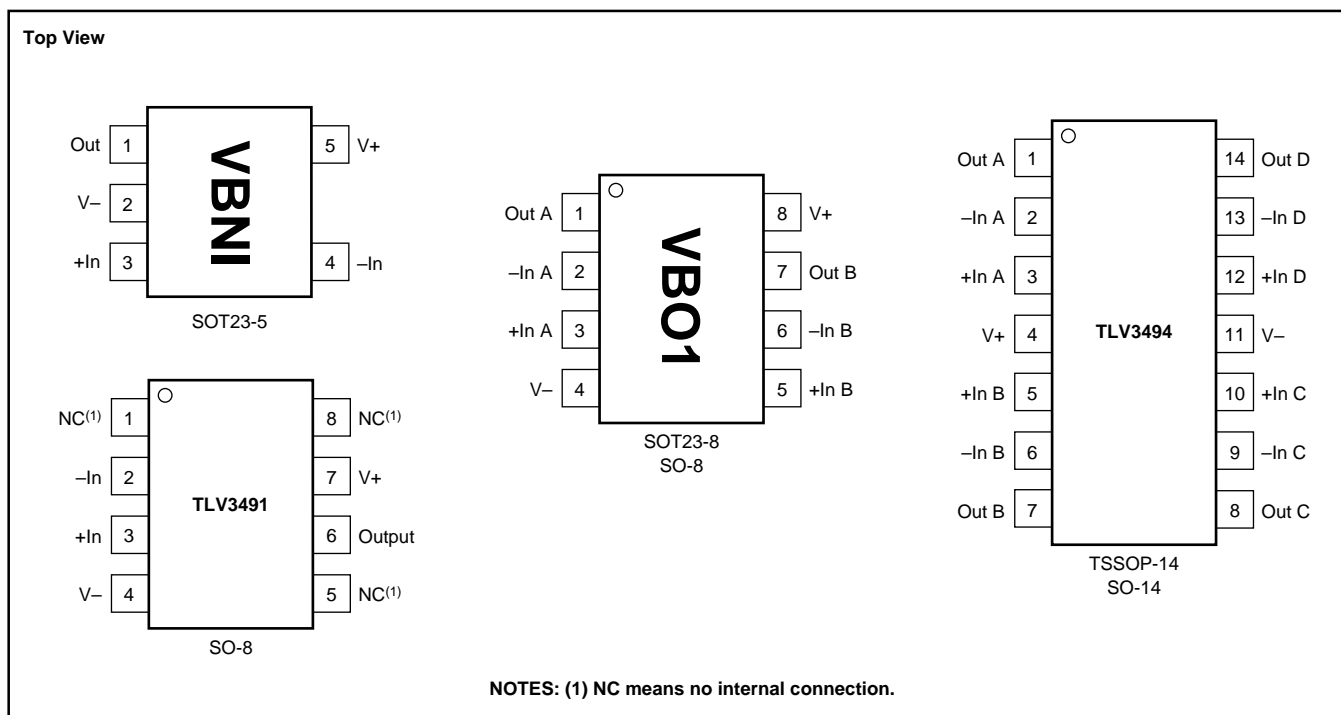

ELECTRICAL CHARACTERISTICS: $V_S = +1.8V$ to $+5.5V$

Boldface limits apply over the specified temperature range, $T_A = -40^\circ\text{C}$ to $+125^\circ\mathbf{C}$.

At $T_A = +25^\circ\text{C}$, and $V_S = +1.8V$ to $+5.5V$, unless otherwise noted.

PARAMETER	CONDITION	TLV3491, TLV3492, TLV3494			UNITS
		MIN	TYP	MAX	
OFFSET VOLTAGE Input Offset Voltage vs Temperature vs Power Supply	V_{OS} dV_{OS}/dT PSRR $V_{CM} = 0V, I_O = 0V$ $T_A = -40^\circ\text{C}$ to $+125^\circ\text{C}$ $V_S = 1.8V$ to $5.5V$		± 3 ± 12 350	± 15 1000	mV $\mu\text{V}/^\circ\text{C}$ $\mu\text{V}/V$
INPUT BIAS CURRENT Input Bias Current Input Offset Current	I_B I_{OS} $V_{CM} = V_{CC}/2$ $V_{CM} = V_{CC}/2$		± 1 ± 1	± 10 ± 10	pA pA
INPUT VOLTAGE RANGE Common-Mode Voltage Range Common-Mode Rejection Ratio	V_{CM} CMRR $V_{CM} = -0.2V$ to $(V+) - 1.5V$ $V_{CM} = -0.2V$ to $(V+) + 0.2V$	$(V-) - 0.2V$ 60 54	74 62	$(V+) + 0.2V$	V dB dB
INPUT CAPACITANCE Common-Mode Differential			2 4		pF pF
SWITCHING CHARACTERISTICS Propagation Delay Time, Low-to-High Propagation Delay Time, High-to-Low Rise Time Fall Time	t_{PLH} t_{PHL} t_R t_F $f = 10\text{kHz}, V_{STEP} = 1V$ Input Overdrive = 10mV Input Overdrive = 100mV Input Overdrive = 10mV Input Overdrive = 100mV $C_L = 10\text{pF}$ $C_L = 10\text{pF}$		12 6 13.5 6.5 100 100		μs μs μs μs ns ns
OUTPUT Voltage Output High from Rail Voltage Output Low from Rail Short-Circuit Current	V_{OH} V_{OL} I_{SC} $V_S = 5V$ $I_{OUT} = 5\text{mA}$ $I_{OUT} = 5\text{mA}$		90 160	200 200	mV mV
POWER SUPPLY Specified Voltage Operating Voltage Range Quiescent Current ⁽¹⁾	V_S I_Q $V_O = 5V, V_O = \text{High}$	1.8 1.8		5.5 5.5 1.2	V V μA
TEMPERATURE RANGE Specified Range Operating Range Storage Range Thermal Resistance, θ_{JA} SOT23-5, SOT23-8 SO-8 SO-14, TSSOP-14		-40 -40 -65		+125 +125 +150	$^\circ\text{C}$ $^\circ\text{C}$ $^\circ\text{C}$ $^\circ\text{C}/W$ $^\circ\text{C}/W$ $^\circ\text{C}/W$

NOTE: (1) I_Q per channel.

TYPICAL CHARACTERISTICS

At $T_A = +25^\circ\text{C}$, $V_S = +1.8\text{V}$ to $+5.5\text{V}$, and Input Overdrive = 100mV , unless otherwise noted.

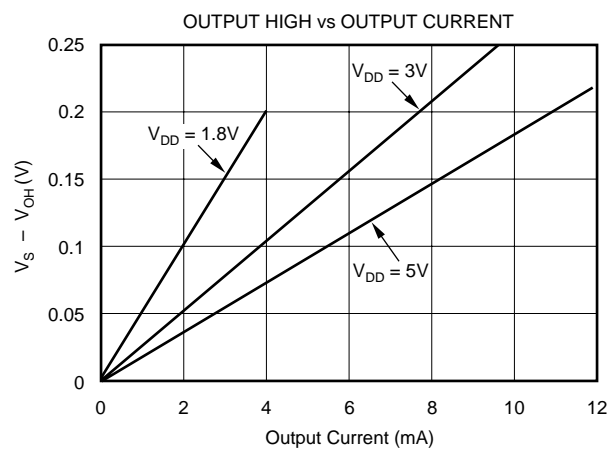
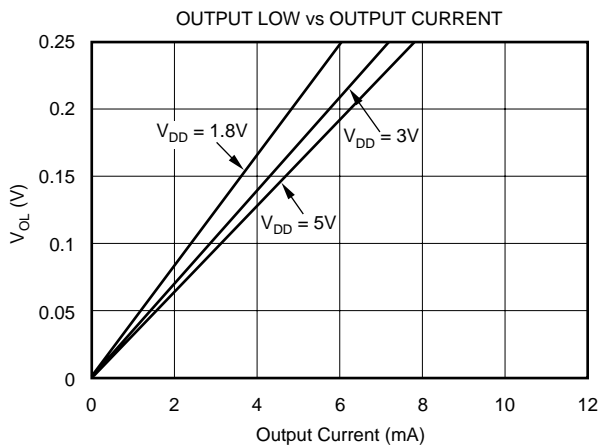
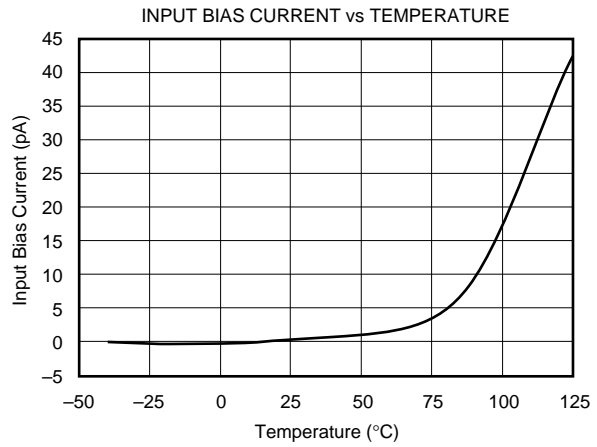
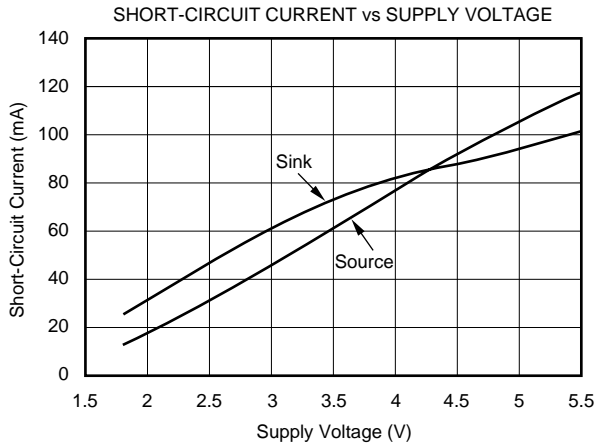
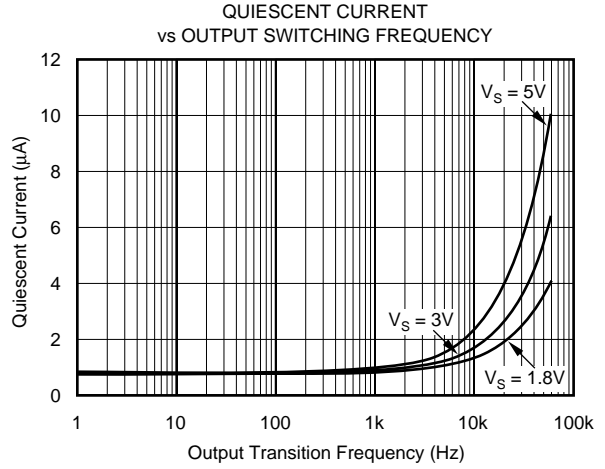
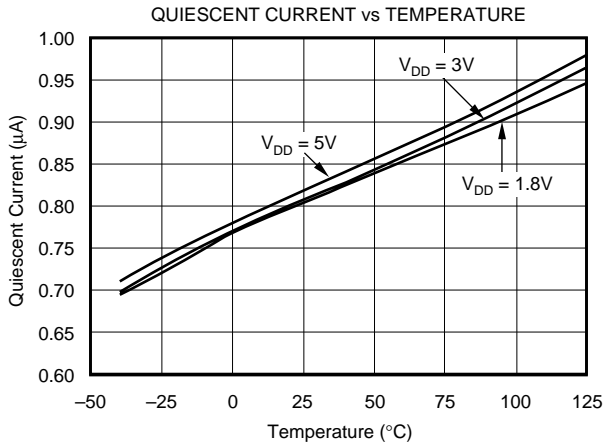

TYPICAL CHARACTERISTICS (Cont.)

At $T_A = +25^\circ\text{C}$, $V_S = +1.8\text{V}$ to $+5.5\text{V}$, and Input Overdrive = 100mV , unless otherwise noted.

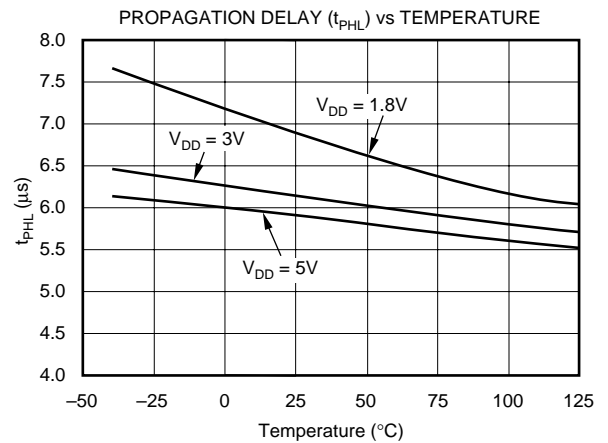
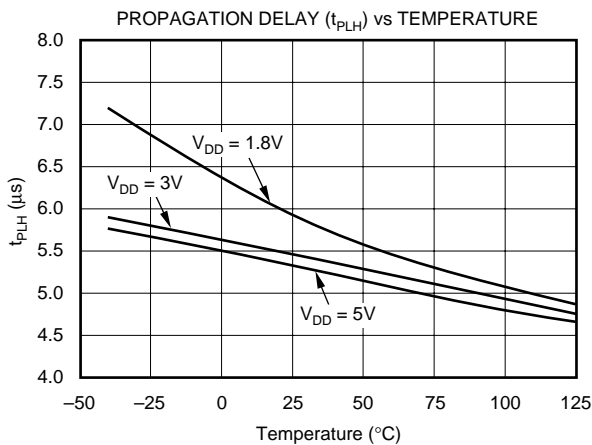
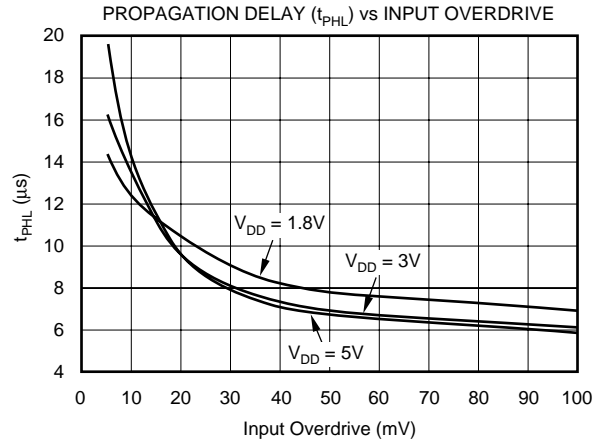
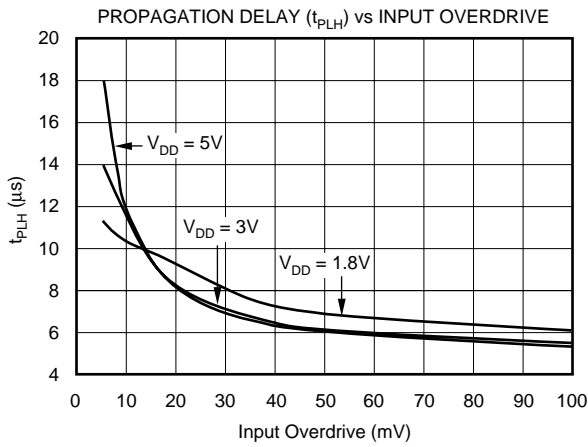
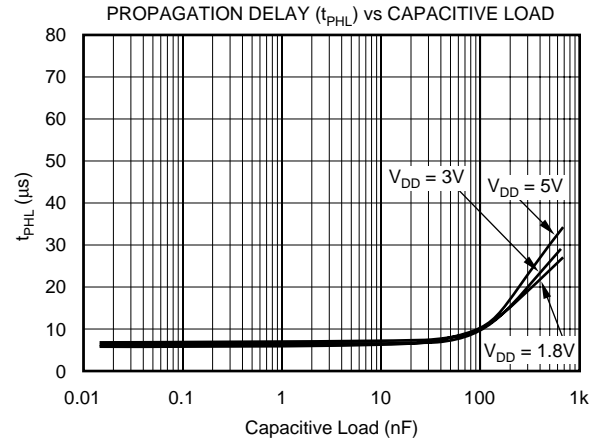
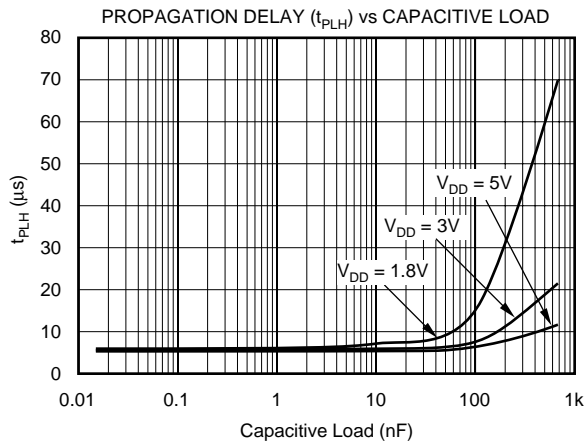

TYPICAL CHARACTERISTICS (Cont.)

At $T_A = +25^\circ\text{C}$, $V_S = +1.8\text{V}$ to $+5.5\text{V}$, and Input Overdrive = 100mV , unless otherwise noted.

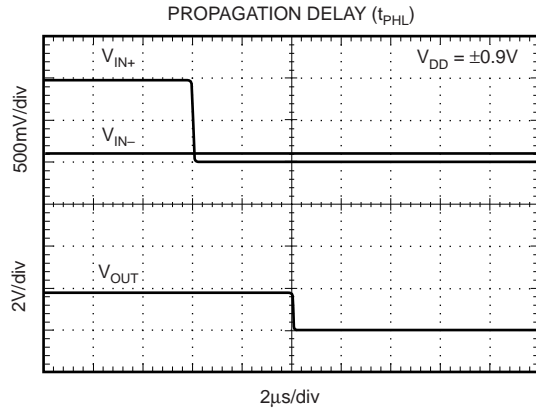
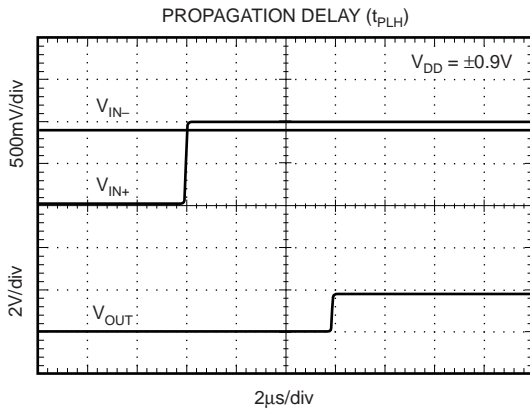
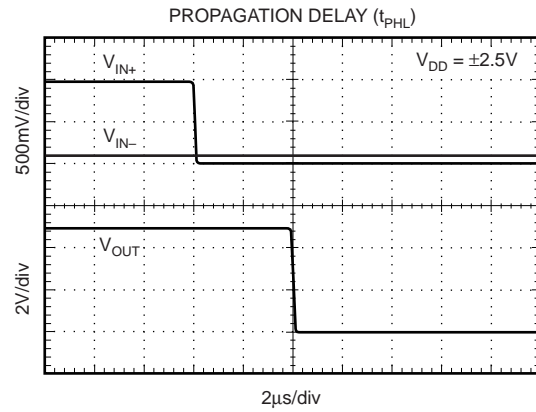
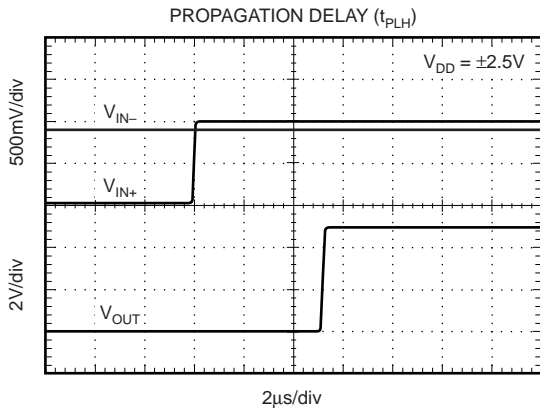

APPLICATIONS INFORMATION

The TLV349x family of comparators features rail-to-rail input and output on supply voltages as low as 1.8V. The push-pull output stage is optimal for reduced power budget applications and features no shoot-through current. Low supply voltages, common-mode input range beyond supply rails, and a typical supply current of 0.8µA make the TLV349x family an excellent candidate for battery-powered applications with single-cell operation.

BOARD LAYOUT

Figure 1 shows the typical connections for the TLV349x. To minimize supply noise, power supplies should be capacitively decoupled by a 0.01µF ceramic capacitor in parallel with a 10µF electrolytic capacitor. Comparators are very sensitive to input noise. Proper grounding (use of ground plane) and guarding of high-impedance nodes will help maintain specified performance of the TLV349x family.

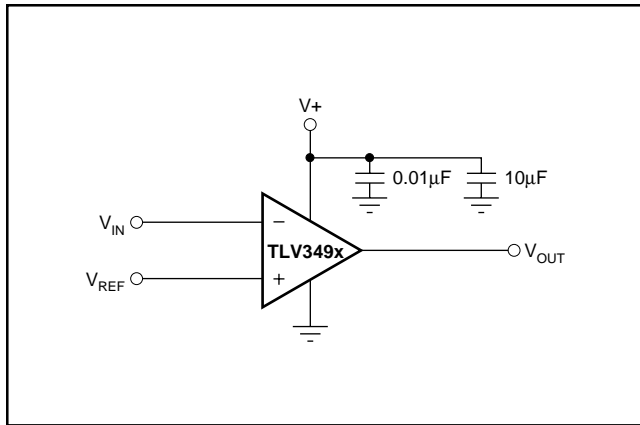

FIGURE 1. Basic Connections of the TLV349x.

SETTING REFERENCE VOLTAGE

It is important to use a stable reference when setting the transition point for the TLV349. The REF1004 provides a 1.25V reference voltage with low drift and only 8µA of quiescent current.

EXTERNAL HYSTERESIS

Comparator inputs have no noise immunity within the range of specified offset voltage ($\pm 15\text{mV}$). For noisy input signals, the comparator output may display multiple switching as input signals move through the switching threshold. The typical comparator threshold of the TLV349x is $\pm 15\text{mV}$. To prevent multiple switching within the comparator threshold of the TLV349x, external hysteresis may be added by connecting a small amount of feedback to the positive input. Figure 2 shows a typical topology used to introduce hysteresis, described by the equation:

$$V_{\text{HYST}} = \frac{V^+ \times R_1}{R_1 + R_2}$$

V_{HYST} will set the value of the transition voltage required to switch the comparator output by increasing the threshold region, thereby reducing sensitivity to noise.

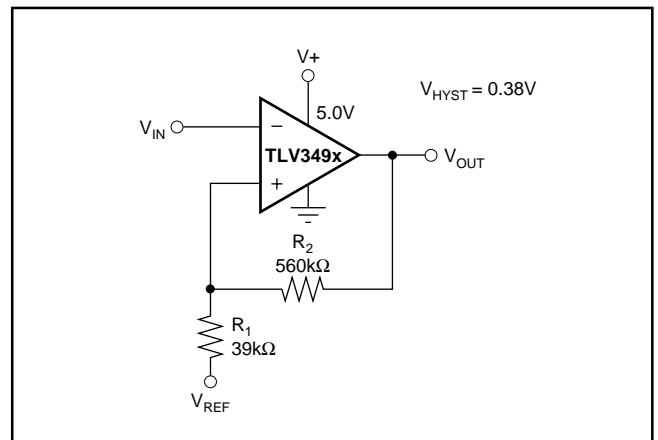

FIGURE 2. Adding Hysteresis to the TLV349x.

APPLICATIONS

RELAXATION OSCILLATOR

The TLV349x can be configured as a relaxation oscillator to provide a simple and inexpensive clock output (see Figure 3.) The capacitor is charged at a rate of $0.69RC$. It also discharges at a rate of $0.69RC$. Therefore, the period is $1.38RC$. R_1 may be a different value than R_2 .

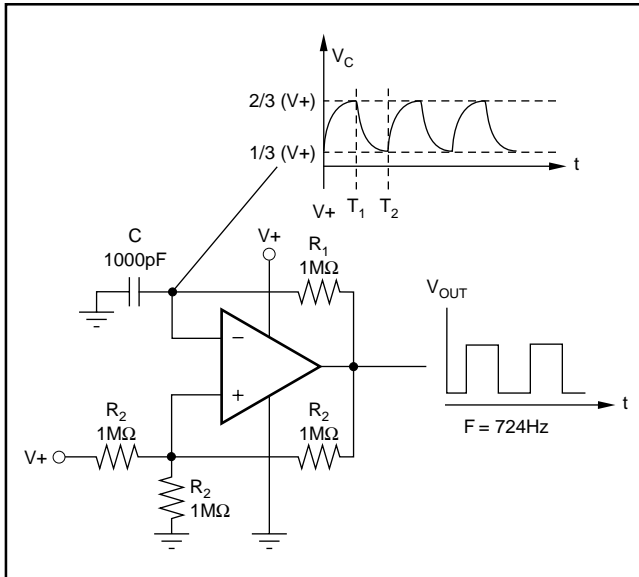

FIGURE 3. TLV349x Configured as a Relaxation Oscillator.

POWER-ON RESET

The reset circuit shown in Figure 4 provides a time delayed release of reset to the MSP430 microcontroller. Operation of the circuit is based on a stabilization time constant of the supply voltage, rather than on a predetermined voltage value. The negative input is a reference voltage created by

a simple resistor divider. These resistor values should be relatively high to reduce the current consumption of the circuit. The positive input is an RC circuit that provides a power-up delay. When power is applied, the output of the comparator is low, holding the processor in the reset condition. Only after allowing time for the supply voltage to stabilize does the positive input of the comparator become higher than the negative input, resulting in a high output state, and releasing the processor for operation. The stabilization time required for the supply voltage is adjustable by the selection of the RC component values. Use of a lower-valued resistor in this portion of the circuit will not increase current consumption because no current flows through the RC circuit after the supply has stabilized. The reset delay time needed depends on the power-up characteristics of the system power supply. R_1 and C_1 are selected to allow enough time for the power supply to stabilize. D1 provides rapid reset if power is lost. In this example, the $R_1 \cdot C_1$ time constant is 10mS.

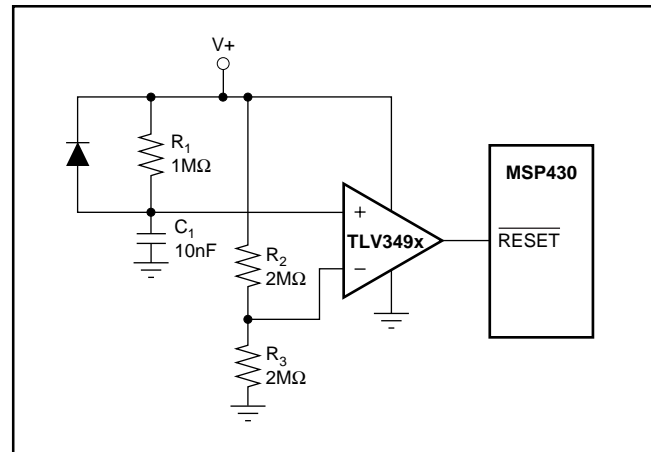

FIGURE 4. The TLV349x Configured as a Reset Circuit for the MSP430.

PACKAGING INFORMATION

ORDERABLE DEVICE	STATUS(1)	PACKAGE TYPE	PACKAGE DRAWING	PINS	PACKAGE QTY
TLV3491AID	ACTIVE	SOIC	D	8	100
TLV3491AIDBVR	ACTIVE	SOP	DBV	5	3000
TLV3491AIDBVT	ACTIVE	SOP	DBV	5	250
TLV3491AIDR	ACTIVE	SOIC	D	8	2500
TLV3492AID	ACTIVE	SOIC	D	8	100
TLV3492AIDCNR	ACTIVE	SSOP	DCN	8	3000
TLV3492AIDCNT	ACTIVE	SSOP	DCN	8	250
TLV3492AIDR	ACTIVE	SOIC	D	8	2500
TLV3494AID	ACTIVE	SOIC	D	14	58
TLV3494AIDR	ACTIVE	SOIC	D	14	2500
TLV3494AIPWR	ACTIVE	TSSOP	PW	14	2500
TLV3494AIPWT	ACTIVE	TSSOP	PW	14	250

(1) The marketing status values are defined as follows:

ACTIVE: Product device recommended for new designs.

LIFEBUY: TI has announced that the device will be discontinued, and a lifetime-buy period is in effect.

NRND: Not recommended for new designs. Device is in production to support existing customers, but TI does not recommend using this part in a new design.

PREVIEW: Device has been announced but is not in production. Samples may or may not be available.

OBSOLETE: TI has discontinued the production of the device.

DBV (R-PDSO-G5)

PLASTIC SMALL-OUTLINE PACKAGE

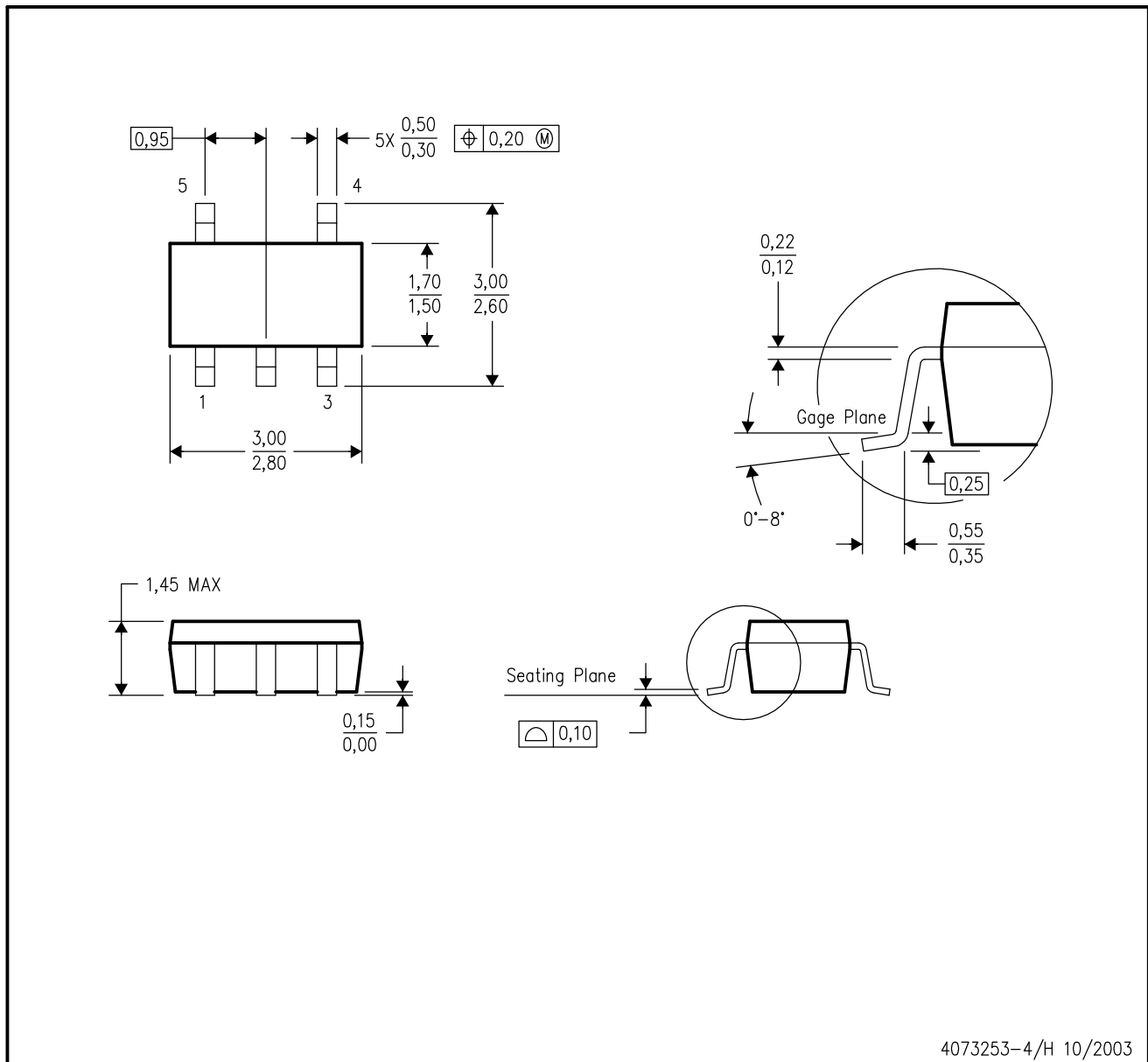

- NOTES:
- A. All linear dimensions are in millimeters.
 - B. This drawing is subject to change without notice.
 - C. Body dimensions do not include mold flash or protrusion.
 - D. Falls within JEDEC MO-178 Variation AA.

DCN (R-PDSO-G8)

PLASTIC SMALL-OUTLINE

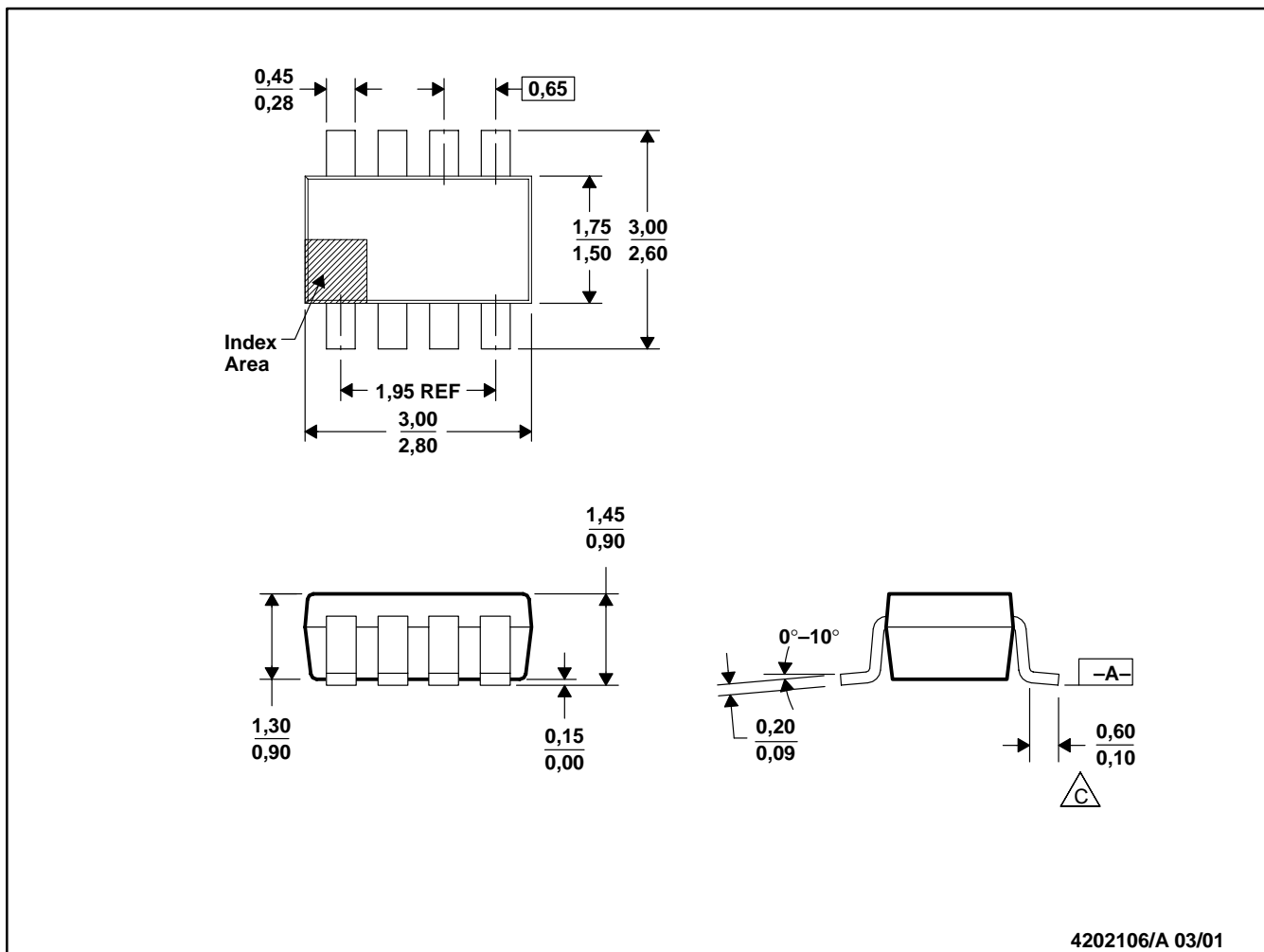

- NOTES: A. All linear dimensions are in millimeters.
 B. This drawing is subject to change without notice.
 C. Foot length measured reference to flat foot surface parallel to Datum A.
 D. Package outline exclusive of mold flash, metal burr and dambar protrusion/intrusion.
 E. Package outline inclusive of solder plating.
 F. A visual index feature must be located within the cross-hatched area.

D (R-PDSO-G14)

PLASTIC SMALL-OUTLINE PACKAGE



- NOTES:
- A. All linear dimensions are in inches (millimeters).
 - B. This drawing is subject to change without notice.
 - C. Body dimensions do not include mold flash or protrusion not to exceed 0.006 (0,15).
 - D. Falls within JEDEC MS-012 variation AB.

D (R-PDSO-G8)

PLASTIC SMALL-OUTLINE PACKAGE

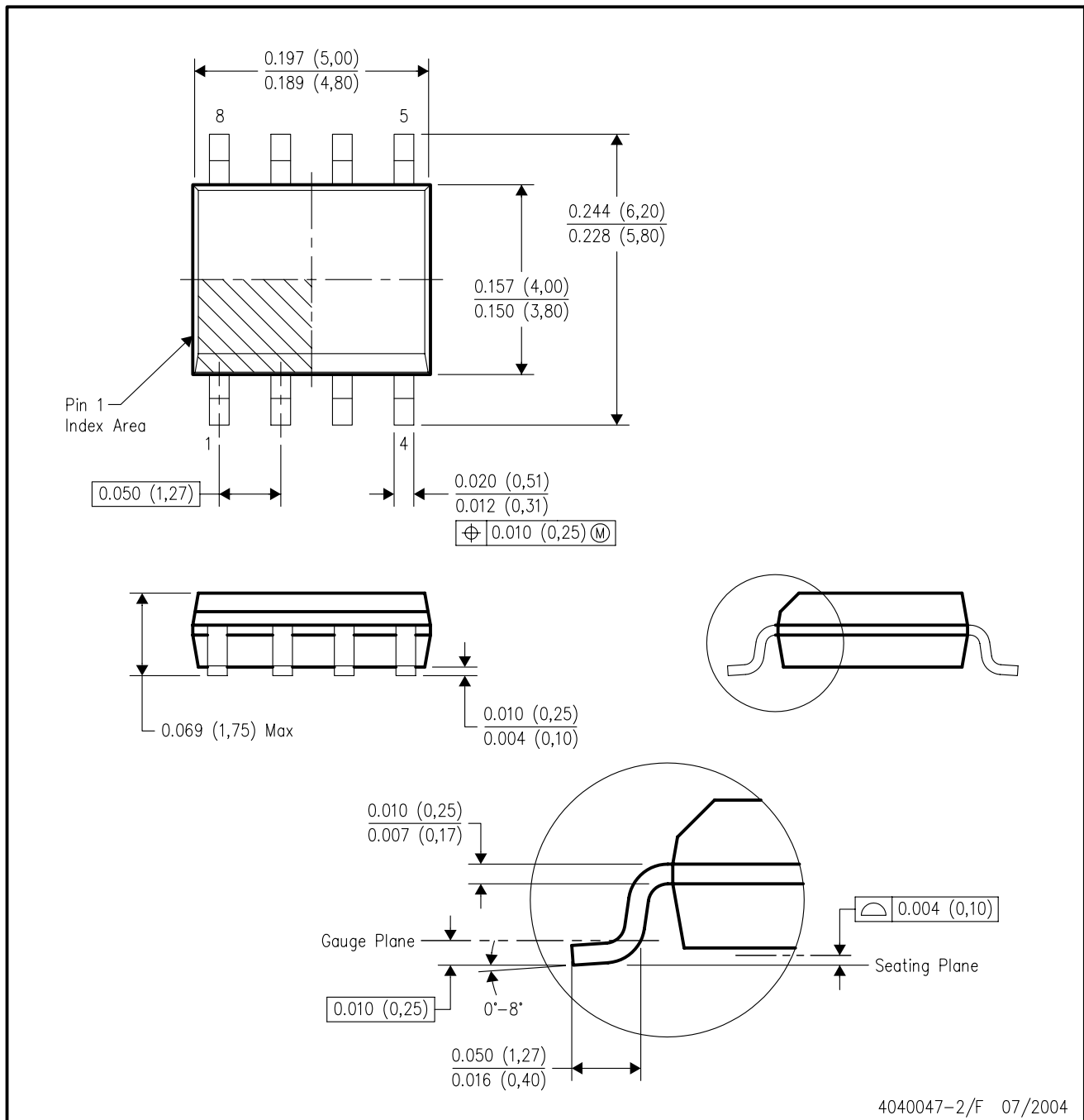

- NOTES:
- A. All linear dimensions are in inches (millimeters).
 - B. This drawing is subject to change without notice.
 - C. Body dimensions do not include mold flash or protrusion not to exceed 0.006 (0,15).
 - D. Falls within JEDEC MS-012 variation AA.

PW (R-PDSO-G**)

PLASTIC SMALL-OUTLINE PACKAGE

14 PINS SHOWN



4040064/F 01/97

- NOTES: A. All linear dimensions are in millimeters.
 B. This drawing is subject to change without notice.
 C. Body dimensions do not include mold flash or protrusion not to exceed 0,15.
 D. Falls within JEDEC MO-153

IMPORTANT NOTICE

Texas Instruments Incorporated and its subsidiaries (TI) reserve the right to make corrections, modifications, enhancements, improvements, and other changes to its products and services at any time and to discontinue any product or service without notice. Customers should obtain the latest relevant information before placing orders and should verify that such information is current and complete. All products are sold subject to TI's terms and conditions of sale supplied at the time of order acknowledgment.

TI warrants performance of its hardware products to the specifications applicable at the time of sale in accordance with TI's standard warranty. Testing and other quality control techniques are used to the extent TI deems necessary to support this warranty. Except where mandated by government requirements, testing of all parameters of each product is not necessarily performed.

TI assumes no liability for applications assistance or customer product design. Customers are responsible for their products and applications using TI components. To minimize the risks associated with customer products and applications, customers should provide adequate design and operating safeguards.

TI does not warrant or represent that any license, either express or implied, is granted under any TI patent right, copyright, mask work right, or other TI intellectual property right relating to any combination, machine, or process in which TI products or services are used. Information published by TI regarding third-party products or services does not constitute a license from TI to use such products or services or a warranty or endorsement thereof. Use of such information may require a license from a third party under the patents or other intellectual property of the third party, or a license from TI under the patents or other intellectual property of TI.

Reproduction of information in TI data books or data sheets is permissible only if reproduction is without alteration and is accompanied by all associated warranties, conditions, limitations, and notices. Reproduction of this information with alteration is an unfair and deceptive business practice. TI is not responsible or liable for such altered documentation.

Resale of TI products or services with statements different from or beyond the parameters stated by TI for that product or service voids all express and any implied warranties for the associated TI product or service and is an unfair and deceptive business practice. TI is not responsible or liable for any such statements.

Following are URLs where you can obtain information on other Texas Instruments products and application solutions:

Products		Applications	
Amplifiers	amplifier.ti.com	Audio	www.ti.com/audio
Data Converters	dataconverter.ti.com	Automotive	www.ti.com/automotive
DSP	dsp.ti.com	Broadband	www.ti.com/broadband
Interface	interface.ti.com	Digital Control	www.ti.com/digitalcontrol
Logic	logic.ti.com	Military	www.ti.com/military
Power Mgmt	power.ti.com	Optical Networking	www.ti.com/opticalnetwork
Microcontrollers	microcontroller.ti.com	Security	www.ti.com/security
		Telephony	www.ti.com/telephony
		Video & Imaging	www.ti.com/video
		Wireless	www.ti.com/wireless

Mailing Address: Texas Instruments
Post Office Box 655303 Dallas, Texas 75265