

# TLV1549C, TLV1549I, TLV1549M 10-BIT ANALOG-TO-DIGITAL CONVERTERS WITH SERIAL CONTROL

SLAS071C – JANUARY 1993 – REVISED MARCH 1995

- 3.3-V Supply Operation
- 10-Bit-Resolution Analog-to-Digital Converter (ADC)
- Inherent Sample and Hold Function
- Total Unadjusted Error . . .  $\pm 1$  LSB Max
- On-Chip System Clock
- Terminal Compatible With TLC1549 and TLC1549x
- Application Report Available†
- CMOS Technology

## description

The TLV1549C, TLV1549I, and TLV1549M are 10-bit, switched-capacitor, successive-approximation, analog-to-digital converters. The devices have two digital inputs and a 3-state output [chip select ( $\overline{CS}$ ), input-output clock (I/O CLOCK), and data output (DATA OUT)] that provide a three-wire interface to the serial port of a host processor.

The sample-and-hold function is automatic. The converter incorporated in the device features differential high-impedance reference inputs that facilitate ratiometric conversion, scaling, and isolation of analog circuitry from logic and supply noise. A switched-capacitor design allows low-error conversion over the full operating free-air temperature range.

The TLV1549C is characterized for operation from 0°C to 70°C. The TLV1549I is characterized for operation from -40°C to 85°C. The TLV1549M is characterized for operation over the full military temperature range of -55°C to 125°C.

D, JG, OR P PACKAGE  
(TOP VIEW)

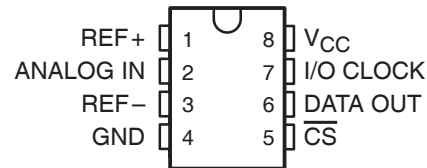

FK PACKAGE  
(TOP VIEW)

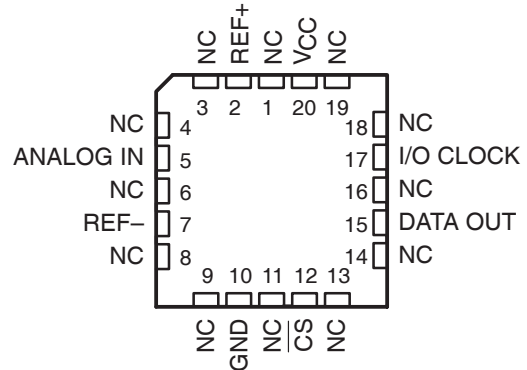

NC – No internal connection

## AVAILABLE OPTIONS

T <sub>A</sub>	PACKAGE			
	SMALL OUTLINE (D)	CHIP CARRIER (FK)	CERAMIC DIP (JG)	PLASTIC DIP (P)
0°C to 70°C	TLV1549CD	—	—	TLV1549CP
-40°C to 85°C	TLV1549ID	—	—	TLV1549IP
-55°C to 125°C	—	TLV1549MFK	TLV1549MJG	—



Please be aware that an important notice concerning availability, standard warranty, and use in critical applications of Texas Instruments semiconductor products and disclaimers thereto appears at the end of this data sheet.

† Interfacing the TLV1549 10-Bit Serial-Out ADC to Popular 3.3-V Microcontrollers (SLAA005)

PRODUCTION DATA information is current as of publication date. Products conform to specifications per the terms of Texas Instruments standard warranty. Production processing does not necessarily include testing of all parameters.

 **TEXAS  
INSTRUMENTS**

POST OFFICE BOX 655303 • DALLAS, TEXAS 75265

Copyright © 1995, Texas Instruments Incorporated

# TLV1549C, TLV1549I, TLV1549M

## 10-BIT ANALOG-TO-DIGITAL CONVERTERS

### WITH SERIAL CONTROL

SLAS071C – JANUARY 1993 – REVISED MARCH 1995

#### typical equivalent inputs

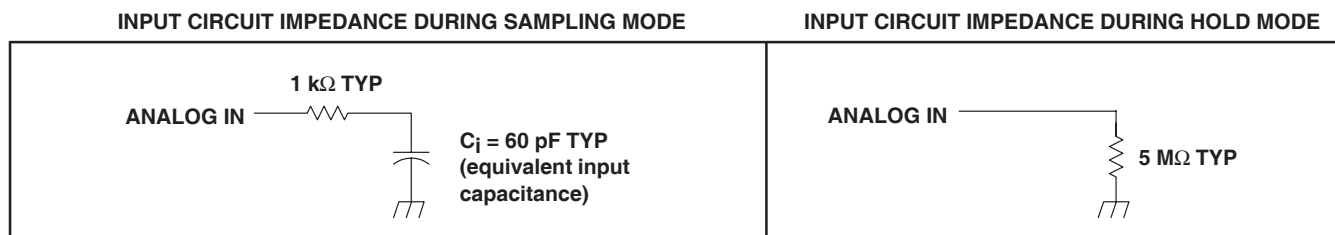

#### functional block diagram

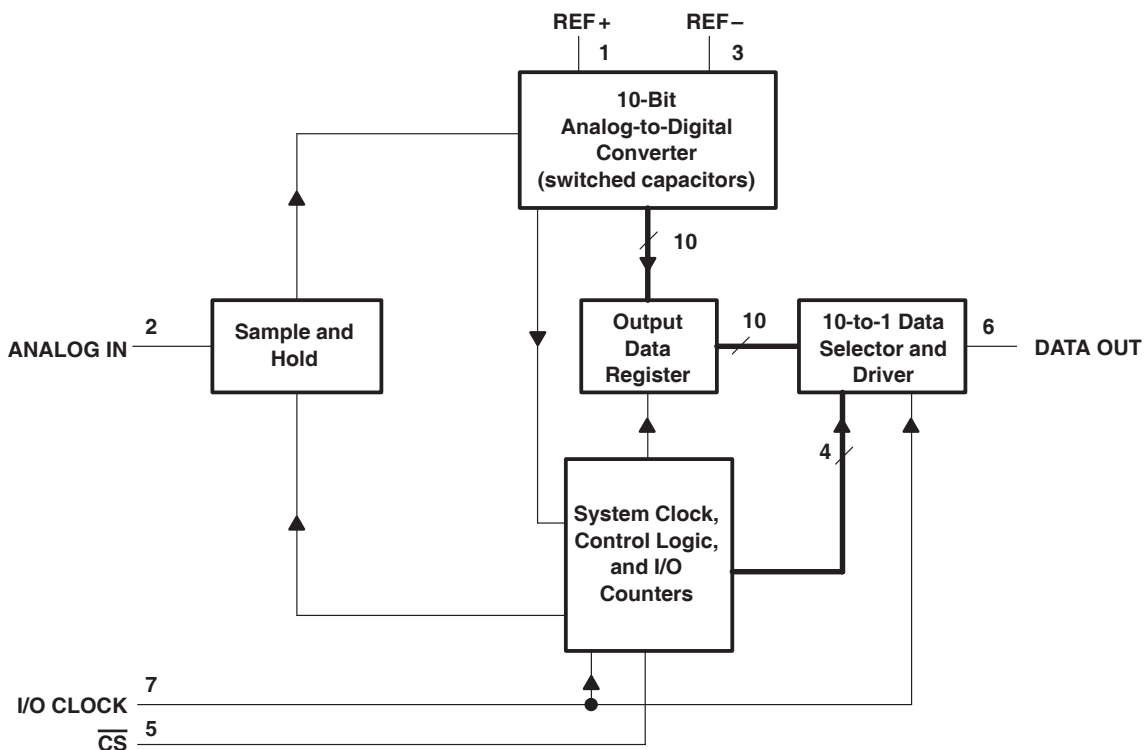

Terminal numbers shown are for the D, JG, and P packages only.

**TLV1549C, TLV1549I, TLV1549M**  
**10-BIT ANALOG-TO-DIGITAL CONVERTERS**  
**WITH SERIAL CONTROL**

SLAS071C – JANUARY 1993 – REVISED MARCH 1995

### Terminal Functions

TERMINAL NAME	NO.	I/O	DESCRIPTION
ANALOG IN	2	I	Analog input. The driving source impedance should be $\leq 1\text{ k}\Omega$ . The external driving source to ANALOG IN should have a current capability $\geq 10\text{ mA}$ .
$\overline{\text{CS}}$	5	I	Chip select. A high-to-low transition on $\overline{\text{CS}}$ resets the internal counters and controls and enables DATA OUT and I/O CLOCK within a maximum of a setup time plus two falling edges of the internal system clock. A low-to-high transition disables I/O CLOCK within a setup time plus two falling edges of the internal system clock.
DATA OUT	6	O	This 3-state serial output for the A/D conversion result is in the high-impedance state when $\overline{\text{CS}}$ is high and active when $\overline{\text{CS}}$ is low. With a valid chip select, DATA OUT is removed from the high-impedance state and is driven to the logic level corresponding to the MSB value of the previous conversion result. The next falling edge of I/O CLOCK drives DATA OUT to the logic level corresponding to the next most significant bit, and the remaining bits are shifted out in order with the LSB appearing on the ninth falling edge of I/O CLOCK. On the tenth falling edge of I/O CLOCK, DATA OUT is driven to a low logic level so that serial interface data transfers of more than ten clocks produce zeroes as the unused LSBs.
GND	4	I	The ground return for internal circuitry. Unless otherwise noted, all voltage measurements are with respect to GND.
I/O CLOCK	7	I	The input/output clock receives the serial I/O CLOCK input and performs the following three functions: 1) On the third falling edge of I/O CLOCK, the analog input voltage begins charging the capacitor array and continues to do so until the tenth falling edge of I/O CLOCK. 2) It shifts the nine remaining bits of the previous conversion data out on DATA OUT. 3) It transfers control of the conversion to the internal state controller on the falling edge of the tenth clock.
REF +	1	I	The upper reference voltage value (nominally $V_{\text{CC}}$ ) is applied to REF+. The maximum input voltage range is determined by the difference between the voltage applied to REF+ and the voltage applied to REF-.
REF -	3	I	The lower reference voltage value (nominally ground) is applied to this REF-.
$V_{\text{CC}}$	8	I	Positive supply voltage

#### detailed description

With chip select ( $\overline{\text{CS}}$ ) inactive (high), the I/O CLOCK input is initially disabled and DATA OUT is in the high-impedance state. When the serial interface takes  $\overline{\text{CS}}$  active (low), the conversion sequence begins with the enabling of I/O CLOCK and the removal of DATA OUT from the high-impedance state. The serial interface then provides the I/O CLOCK sequence to I/O CLOCK and receives the previous conversion result from DATA OUT. I/O CLOCK receives an input sequence that is between 10 and 16 clocks long from the host serial interface. The first ten I/O clocks provide the control timing for sampling the analog input.

There are six basic serial interface timing modes that can be used with the TLV1549. These modes are determined by the speed of I/O CLOCK and the operation of  $\overline{\text{CS}}$  as shown in Table 1. These modes are: (1) a fast mode with a 10-clock transfer and  $\overline{\text{CS}}$  inactive (high) between transfers, (2) a fast mode with a 10-clock transfer and  $\overline{\text{CS}}$  active (low) continuously, (3) a fast mode with an 11- to 16-clock transfer and  $\overline{\text{CS}}$  inactive (high) between transfers, (4) a fast mode with a 16-bit transfer and  $\overline{\text{CS}}$  active (low) continuously, (5) a slow mode with an 11- to 16-clock transfer and  $\overline{\text{CS}}$  inactive (high) between transfers, and (6) a slow mode with a 16-clock transfer and  $\overline{\text{CS}}$  active (low) continuously.

The MSB of the previous conversion appears on DATA OUT on the falling edge of  $\overline{\text{CS}}$  in mode 1, mode 3, and mode 5, within 21  $\mu\text{s}$  from the falling edge of the tenth I/O CLOCK in mode 2 and mode 4, and following the 16th clock falling edge in mode 6. The remaining nine bits are shifted out on the next nine falling edges of the I/O CLOCK. Ten bits of data are transmitted to the host serial interface through DATA OUT. The number of serial clock pulses used also depends on the mode of operation, but a minimum of ten clock pulses is required for conversion to begin. On the tenth clock falling edge, the internal logic takes DATA OUT low to ensure that the remaining bit values are zero if the I/O CLOCK transfer is more than ten clocks long.

Table 1 lists the operational modes with respect to the state of  $\overline{\text{CS}}$ , the number of I/O serial transfer clocks that can be used, and the timing on which the MSB of the previous conversion appears at the output.



# TLV1549C, TLV1549I, TLV1549M

## 10-BIT ANALOG-TO-DIGITAL CONVERTERS

### WITH SERIAL CONTROL

SLAS071C – JANUARY 1993 – REVISED MARCH 1995

**Table 1. Mode Operation**

MODES		$\overline{CS}$	NO. OF I/O CLOCKS	MSB AT DATA OUT†	TIMING DIAGRAM
Fast Modes	Mode 1	High between conversion cycles	10	$\overline{CS}$ falling edge	Figure 6
	Mode 2	Low continuously	10	Within 21 $\mu$ s	Figure 7
	Mode 3	High between conversion cycles	11 to 16‡	$\overline{CS}$ falling edge	Figure 8
	Mode 4	Low continuously	16‡	Within 21 $\mu$ s	Figure 9
Slow Modes	Mode 5	High between conversion cycles	11 to 16‡	$\overline{CS}$ falling edge	Figure 10
	Mode 6	Low continuously	16‡	16th clock falling edge	Figure 11

† This timing also initiates serial-interface communication.

‡ No more than 16 clocks should be used.

All the modes require a minimum period of 21  $\mu$ s after the falling edge of the tenth I/O CLOCK before a new transfer sequence can begin. During a serial I/O CLOCK data transfer,  $\overline{CS}$  must be active (low) so that the I/O CLOCK input is enabled. When  $\overline{CS}$  is toggled between data transfers (modes 1, 3, and 5), the transitions at  $\overline{CS}$  are recognized as valid only if the level is maintained for a minimum period of 1.425  $\mu$ s after the transition. If the transfer is more than ten I/O clocks (modes 3, 4, 5, and 6), the rising edge of the eleventh clock must occur within 9.5  $\mu$ s after the falling edge of the tenth I/O CLOCK; otherwise, the device could lose synchronization with the host serial interface and  $\overline{CS}$  has to be toggled to restore proper operation.

#### fast modes

The device is in a fast mode when the serial I/O CLOCK data transfer is completed within 21  $\mu$ s from the falling edge of the tenth I/O CLOCK. With a 10-clock serial transfer, the device can only run in a fast mode.

#### **mode 1: fast mode, $\overline{CS}$ inactive (high) between transfers, 10-clock transfer**

In this mode,  $\overline{CS}$  is inactive (high) between serial I/O-CLOCK transfers and each transfer is ten clocks long. The falling edge of  $\overline{CS}$  begins the sequence by removing DATA OUT from the high-impedance state. The rising edge of  $\overline{CS}$  ends the sequence by returning DATA OUT to the high-impedance state within the specified delay time. Also, the rising edge of  $\overline{CS}$  disables I/O CLOCK within a setup time plus two falling edges of the internal system clock.

#### **mode 2: fast mode, $\overline{CS}$ active (low) continuously, 10-clock transfer**

In this mode,  $\overline{CS}$  is active (low) between serial I/O-CLOCK transfers and each transfer is ten clocks long. After the initial conversion cycle,  $\overline{CS}$  is held active (low) for subsequent conversions. Within 21  $\mu$ s after the falling edge of the tenth I/O CLOCK, the MSB of the previous conversion appears at DATA OUT.

#### **mode 3: fast mode, $\overline{CS}$ inactive (high) between transfers, 11- to 16-clock transfer**

In this mode,  $\overline{CS}$  is inactive (high) between serial I/O-CLOCK transfers and each transfer can be 11 to 16 clocks long. The falling edge of  $\overline{CS}$  begins the sequence by removing DATA OUT from the high-impedance state. The rising edge of  $\overline{CS}$  ends the sequence by returning DATA OUT to the high-impedance state within the specified delay time. Also, the rising edge of  $\overline{CS}$  disables I/O CLOCK within a setup time plus two falling edges of the internal system clock.

#### **mode 4: fast mode, $\overline{CS}$ active (low) continuously, 16-clock transfer**

In this mode,  $\overline{CS}$  is active (low) between serial I/O-CLOCK transfers and each transfer must be exactly 16 clocks long. After the initial conversion cycle,  $\overline{CS}$  is held active (low) for subsequent conversions. Within 21  $\mu$ s after the falling edge of the tenth I/O CLOCK, the MSB of the previous conversion appears at DATA OUT.

#### slow modes

In a slow mode, the serial I/O CLOCK data transfer is completed after 21  $\mu$ s from the falling edge of the tenth I/O CLOCK.



---

**mode 5: slow mode,  $\overline{CS}$  inactive (high) between transfers, 11- to 16-clock transfer**

In this mode,  $\overline{CS}$  is inactive (high) between serial I/O-CLOCK transfers and each transfer can be 11 to 16 clocks long. The falling edge of  $\overline{CS}$  begins the sequence by removing DATA OUT from the high-impedance state. The rising edge of  $\overline{CS}$  ends the sequence by returning DATA OUT to the high-impedance state within the specified delay time. Also, the rising edge of  $\overline{CS}$  disables I/O CLOCK within a setup time plus two falling edges of the internal system clock.

**mode 6: slow mode,  $\overline{CS}$  active (low) continuously, 16-clock transfer**

In this mode,  $\overline{CS}$  is active (low) between serial I/O-CLOCK transfers and each transfer must be exactly 16 clocks long. After the initial conversion cycle,  $\overline{CS}$  is held active (low) for subsequent conversions. The falling edge of the sixteenth I/O CLOCK then begins each sequence by removing DATA OUT from the low state, allowing the MSB of the previous conversion to appear immediately at DATA OUT. The device is then ready for the next 16-clock transfer initiated by the serial interface.

**analog input sampling**

Sampling of the analog input starts on the falling edge of the third I/O CLOCK, and sampling continues for seven I/O CLOCK periods. The sample is held on the falling edge of the tenth I/O CLOCK.

**converter and analog input**

The CMOS threshold detector in the successive-approximation conversion system determines each bit by examining the charge on a series of binary-weighted capacitors (see Figure 1). In the first phase of the conversion process, the analog input is sampled by closing the  $S_C$  switch and all  $S_T$  switches simultaneously. This action charges all the capacitors to the input voltage.

In the next phase of the conversion process, all  $S_T$  and  $S_C$  switches are opened and the threshold detector begins identifying bits by identifying the charge (voltage) on each capacitor relative to the reference (REF–) voltage. In the switching sequence, ten capacitors are examined separately until all ten bits are identified and then the charge-convert sequence is repeated. In the first step of the conversion phase, the threshold detector looks at the first capacitor (weight = 512). Node 512 of this capacitor is switched to the REF+ voltage, and the equivalent nodes of all the other capacitors on the ladder are switched to REF–. If the voltage at the summing node is greater than the trip point of the threshold detector (approximately one-half  $V_{CC}$ ), a bit 0 is placed in the output register and the 512-weight capacitor is switched to REF–. If the voltage at the summing node is less than the trip point of the threshold detector, a bit 1 is placed in the register and this 512-weight capacitor remains connected to REF+ through the remainder of the successive-approximation process. The process is repeated for the 256-weight capacitor, the 128-weight capacitor, and so forth down the line until all bits are determined.

With each step of the successive-approximation process, the initial charge is redistributed among the capacitors. The conversion process relies on charge redistribution to determine the bits from MSB to LSB.

# TLV1549C, TLV1549I, TLV1549M

## 10-BIT ANALOG-TO-DIGITAL CONVERTERS

### WITH SERIAL CONTROL

SLAS071C – JANUARY 1993 – REVISED MARCH 1995

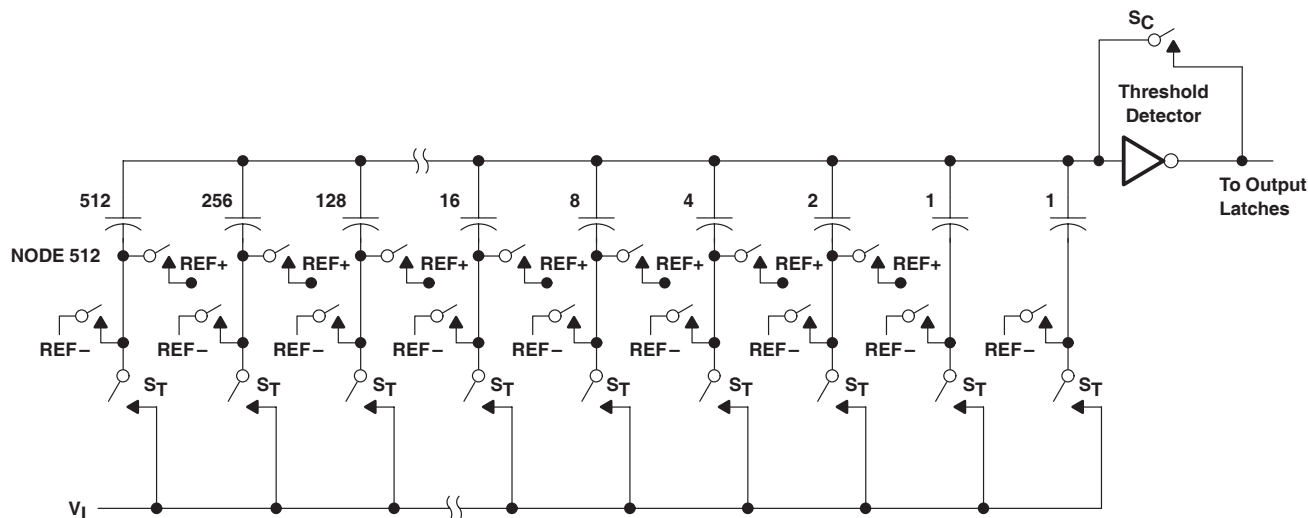

Figure 1. Simplified Model of the Successive-Approximation System

#### chip-select operation

The trailing edge of  $\overline{CS}$  starts all modes of operation, and  $\overline{CS}$  can abort a conversion sequence in any mode. A high-to-low transition on  $\overline{CS}$  within the specified time during an ongoing cycle aborts the cycle, and the device returns to the initial state (the contents of the output data register remain at the previous conversion result). Exercise care to prevent  $\overline{CS}$  from being taken low close to completion of conversion because the output data may be corrupted.

#### reference voltage inputs

There are two reference inputs used with the TLV1549: REF+ and REF-. These voltage values establish the upper and lower limits of the analog input to produce a full-scale and zero reading, respectively. The values of REF+, REF-, and the analog input should not exceed the positive supply or be lower than GND consistent with the specified absolute maximum ratings. The digital output is at full scale when the input signal is equal to or higher than REF+ and at zero when the input signal is equal to or lower than REF-.

#### absolute maximum ratings over operating free-air temperature range (unless otherwise noted)†

Supply voltage range, $V_{CC}$ (see Note 1):	TLV1549C	.....	-0.5 V to 6.5 V
	TLV1549I	.....	-0.5 V to 6.5 V
	TLV1549M	.....	-0.5 V to 6 V
Input voltage range, $V_I$ (any input)	.....		-0.3 V to $V_{CC} + 0.3$ V
Output voltage range, $V_O$	.....		-0.3 V to $V_{CC} + 0.3$ V
Positive reference voltage, $V_{ref+}$	.....		$V_{CC} + 0.1$ V
Negative reference voltage, $V_{ref-}$	.....		-0.1 V
Peak input current (any input)	.....		$\pm 20$ mA
Peak total input current (all inputs)	.....		$\pm 30$ mA
Operating free-air temperature range, $T_A$ :	TLV1549C	.....	0°C to 70°C
	TLV1549I	.....	-40°C to 85°C
	TLV1549M	.....	-55°C to 125°C
Storage temperature range, $T_{stg}$	.....		-65°C to 150°C
Lead temperature 1,6 mm (1/16 inch) from the case for 10 seconds	.....		260°C

† Stresses beyond those listed under "absolute maximum ratings" may cause permanent damage to the device. These are stress ratings only, and functional operation of the device at these or any other conditions beyond those indicated under "recommended operating conditions" is not implied. Exposure to absolute-maximum-rated conditions for extended periods may affect device reliability.

NOTE 1: All voltage values are with respect to ground with REF- and GND wired together (unless otherwise noted).



POST OFFICE BOX 655303 • DALLAS, TEXAS 75265

# TLV1549C, TLV1549I, TLV1549M 10-BIT ANALOG-TO-DIGITAL CONVERTERS WITH SERIAL CONTROL

SLAS071C – JANUARY 1993 – REVISED MARCH 1995

## recommended operating conditions

		MIN	NOM	MAX	UNIT
Supply voltage, $V_{CC}$		3	3.3	3.6	V
Positive reference voltage, $V_{ref+}$ (see Note 2)		$V_{CC}$			V
Negative reference voltage, $V_{ref-}$ (see Note 2)		0			V
Differential reference voltage, $V_{ref+} - V_{ref-}$ (see Note 2)		2.5	$V_{CC}$	$V_{CC} + 0.2$	V
Analog input voltage (see Note 2)		0			$V_{CC}$
High-level control input voltage, $V_{IH}$	$V_{CC} = 3\text{ V to }3.6\text{ V}$	2			V
Low-level control input voltage, $V_{IL}$	$V_{CC} = 3\text{ V to }3.6\text{ V}$	0.6			V
Clock frequency at I/O CLOCK (see Note 3)		0			2.1
Setup time, $\overline{CS}$ low before first I/O CLOCK $\uparrow$ , $t_{su}(CS)$ (see Note 4)		1.425			$\mu\text{s}$
Hold time, $\overline{CS}$ low after last I/O CLOCK $\downarrow$ , $t_h(CS)$		0			ns
Pulse duration, I/O CLOCK high, $t_{WH}(I/O)$		190			ns
Pulse duration, I/O CLOCK low, $t_{WL}(I/O)$		190			ns
Transition time, I/O CLOCK, $t_t(I/O)$ (see Note 5 and Figure 5)		1			$\mu\text{s}$
Transition time, $\overline{CS}$ , $t_t(CS)$		10			$\mu\text{s}$
Operating free-air temperature, $T_A$	TLV1549C	0			70
	TLV1549I	-40			85
	TLV1549M	-55			125

- NOTES:
- Analog input voltages greater than that applied to REF+ convert as all ones (1111111111), while input voltages less than that applied to REF- convert as all zeros (0000000000). The TLV1549 is functional with reference voltages down to 1 V ( $V_{ref+} - V_{ref-}$ ); however, the electrical specifications are no longer applicable.
  - For 11- to 16-bit transfers, after the tenth I/O CLOCK falling edge ( $\leq 2\text{ V}$ ), at least one I/O CLOCK rising edge ( $\geq 2\text{ V}$ ) must occur within 9.5  $\mu\text{s}$ .
  - To minimize errors caused by noise at  $\overline{CS}$ , the internal circuitry waits for a setup time plus two falling edges of the internal system clock after  $\overline{CS}\downarrow$  before responding to the I/O CLOCK. Therefore, no attempt should be made to clock out the data until the minimum  $\overline{CS}$  setup time has elapsed.
  - This is the time required for the clock input signal to fall from  $V_{IHmin}$  to  $V_{ILmax}$  or to rise from  $V_{ILmax}$  to  $V_{IHmin}$ . In the vicinity of normal room temperature, the device functions with input clock transition time as slow as 1  $\mu\text{s}$  for remote data-acquisition applications where the sensor and the A/D converter are placed several feet away from the controlling microprocessor.

**TLV1549C, TLV1549I, TLV1549M**  
**10-BIT ANALOG-TO-DIGITAL CONVERTERS**  
**WITH SERIAL CONTROL**

SLAS071C – JANUARY 1993 – REVISED MARCH 1995

**electrical characteristics over recommended operating free-air temperature range,  
 $V_{CC} = V_{ref+} = 3\text{ V to }3.6\text{ V}$ , I/O CLOCK frequency = 2.1 MHz (unless otherwise noted)**

PARAMETER		TEST CONDITIONS	MIN	TYP†	MAX	UNIT
VOH	High-level output voltage	$V_{CC} = 3\text{ V}$ , $I_{OH} = -1.6\text{ mA}$	2.4			V
		$V_{CC} = 3\text{ V to }3.6\text{ V}$ , $I_{OH} = -20\text{ }\mu\text{A}$	$V_{CC} - 0.1$			
VOL	Low-level output voltage	$V_{CC} = 3\text{ V}$ , $I_{OL} = 1.6\text{ mA}$			0.4	V
		$V_{CC} = 3\text{ V to }3.6\text{ V}$ , $I_{OL} = 20\text{ }\mu\text{A}$			0.1	
IOZ	Off-state (high-impedance-state) output current	$V_O = V_{CC}$ , $\overline{CS}$ at $V_{CC}$			10	$\mu\text{A}$
		$V_O = 0$ , $\overline{CS}$ at $V_{CC}$			-10	
IIH	High-level input current	$V_I = V_{CC}$	0.005		2.5	$\mu\text{A}$
IIL	Low-level input current	$V_I = 0$	-0.005		-2.5	$\mu\text{A}$
ICC	Operating supply current	$\overline{CS}$ at 0 V	0.4		2.5	mA
Analog input leakage current		$V_I = V_{CC}$			1	$\mu\text{A}$
		$V_I = 0$			-1	
Maximum static analog reference current into REF+		$V_{ref+} = V_{CC}$ , $V_{ref-} = \text{GND}$			10	$\mu\text{A}$
Ci	Input capacitance	TLV1549C, I (Analog)	During sample cycle		30	pF
		TLV1549M, (Analog)	During sample cycle		30	
		TLV1549C, I (Control)			5	
		TLV1549M, (Control)			5	

† All typical values are at  $V_{CC} = 3.3\text{ V}$ ,  $T_A = 25^\circ\text{C}$ .

**TLV1549C, TLV1549I, TLV1549M**  
**10-BIT ANALOG-TO-DIGITAL CONVERTERS**  
**WITH SERIAL CONTROL**

SLAS071C – JANUARY 1993 – REVISED MARCH 1995

**operating characteristics over recommended operating free-air temperature range,  
 $V_{CC} = V_{ref+} = 3\text{ V to }3.6\text{ V}$ , I/O CLOCK frequency = 2.1 MHz**

PARAMETER	TEST CONDITIONS	MIN	MAX	UNIT
Linearity error (see Note 6)			±1	LSB
Zero error (see Note 7)	See Note 2		±1	LSB
Full-scale error (see Note 7)	See Note 2		±1	LSB
Total unadjusted error (see Note 8)			±1	LSB
$t_{conv}$ Conversion time	See Figures 6–11		21	µs
$t_c$ Total cycle time (access, sample, and conversion)	See Figures 6–11 and Note 9		21 + 10 I/O CLOCK periods	µs
$t_v$ Valid time, DATA OUT remains valid after I/O CLOCK↓	See Figure 5	10		ns
$t_d(I/O-DATA)$ Delay time, I/O CLOCK↓ to DATA OUT valid	See Figure 5		240	ns
$t_{PZH}$ , $t_{PZL}$ Enable time, $\overline{CS}$ ↓ to DATA OUT (MSB driven)	See Figure 3		1.3	µs
$t_{PHZ}$ , $t_{PLZ}$ Disable time, $\overline{CS}$ ↑ to DATA OUT (high impedance)	See Figure 3		180	ns
$t_r(\text{bus})$ Rise time, data bus	See Figure 5		300	ns
$t_f(\text{bus})$ Fall time, data bus	See Figure 5		300	ns
$t_d(I/O-CS)$ Delay time, 10th I/O CLOCK↓ to $\overline{CS}$ ↓ to abort conversion (see Note 10)			9	µs

- NOTES: 2. Analog input voltages greater than that applied to REF + convert as all ones (11111111), while input voltages less than that applied to REF – convert as all zeros (00000000). The device is functional with reference voltages down to 1 V ( $V_{ref+} - V_{ref-}$ ); however, the electrical specifications are no longer applicable.
6. Linearity error is the maximum deviation from the best straight line through the A/D transfer characteristics.
7. Zero error is the difference between 00000000 and the converted output for zero input voltage; full-scale error is the difference between 11111111 and the converted output for full-scale input voltage.
8. Total unadjusted error comprises linearity, zero, and full-scale errors.
9. I/O CLOCK period = 1/(I/O CLOCK frequency). Sampling begins on the falling edge of the third I/O CLOCK, continues for seven I/O CLOCK periods, and ends on the falling edge of the tenth I/O CLOCK (see Figure 5).
10. Any transitions of  $\overline{CS}$  are recognized as valid only if the level is maintained for a minimum of a setup time plus two falling edges of the internal clock (1.425 µs) after the transition.

TLV1549C, TLV1549I, TLV1549M  
 10-BIT ANALOG-TO-DIGITAL CONVERTERS  
 WITH SERIAL CONTROL

SLAS071C – JANUARY 1993 – REVISED MARCH 1995

PARAMETER MEASUREMENT INFORMATION

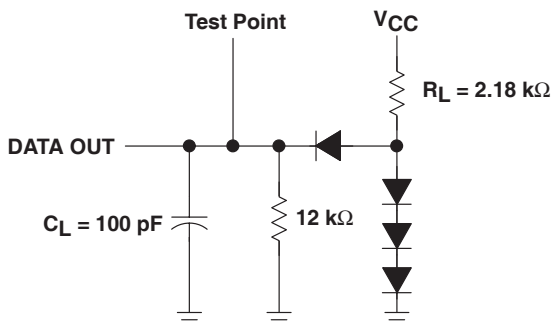

Figure 2. Load Circuit

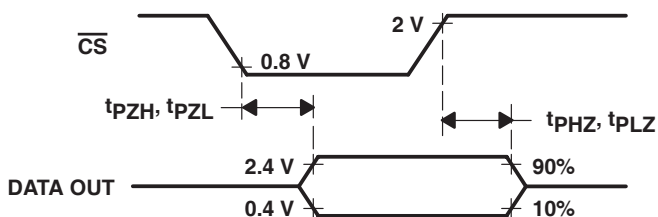

Figure 3. DATA OUT to Hi-Z Voltage Waveforms

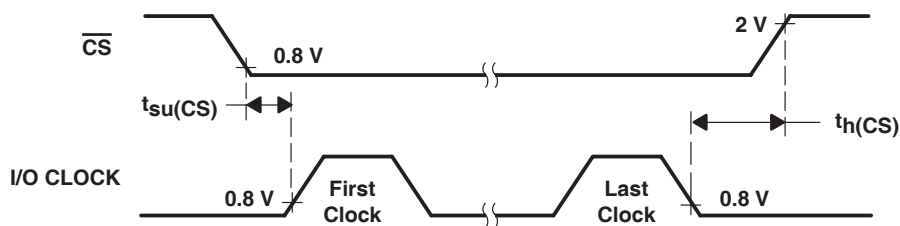

Figure 4. CS to I/O CLOCK Voltage Waveforms

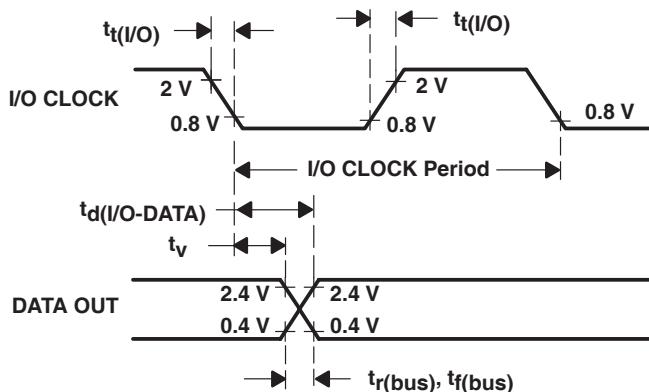

Figure 5. I/O CLOCK and DATA OUT Voltage Waveforms

PARAMETER MEASUREMENT INFORMATION

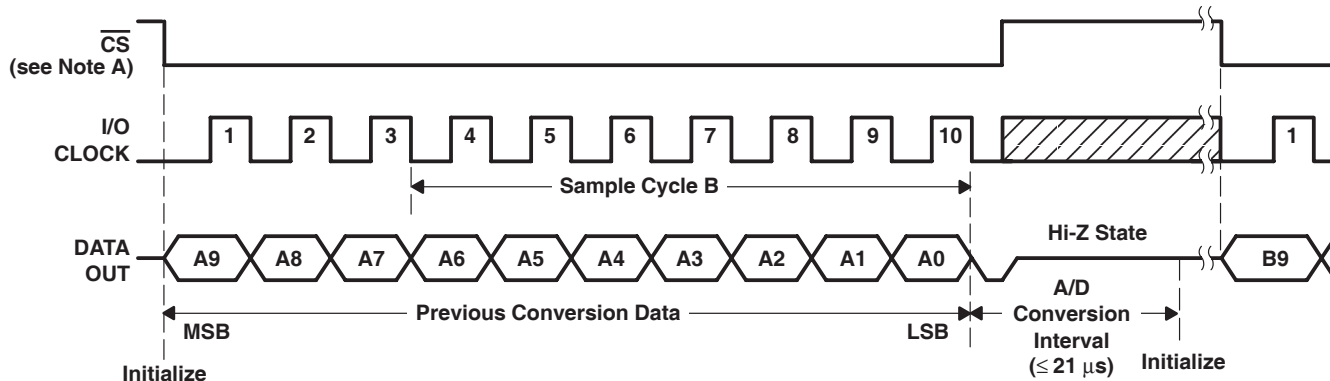

Figure 6. Timing for 10-Clock Transfer Using  $\overline{CS}$

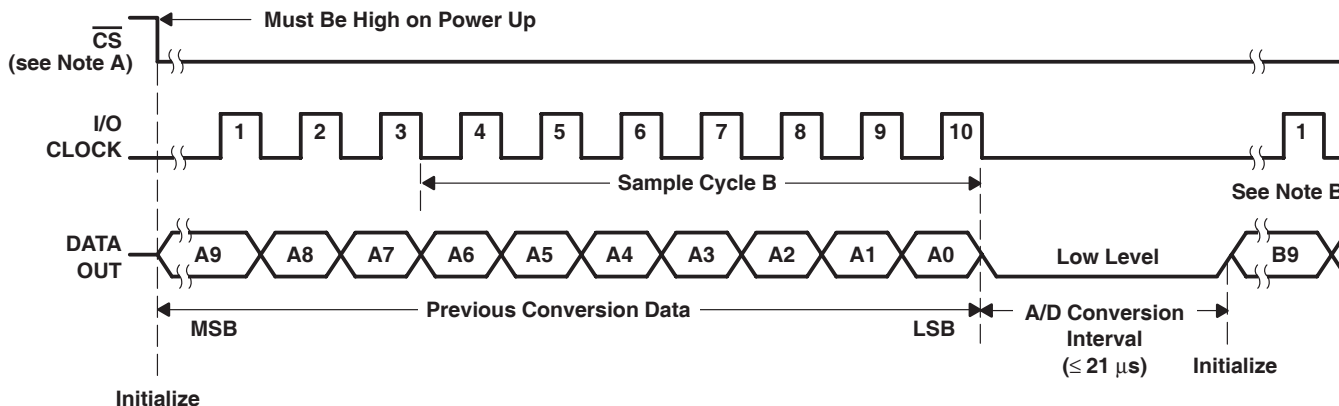

Figure 7. Timing for 10-Clock Transfer Not Using  $\overline{CS}$

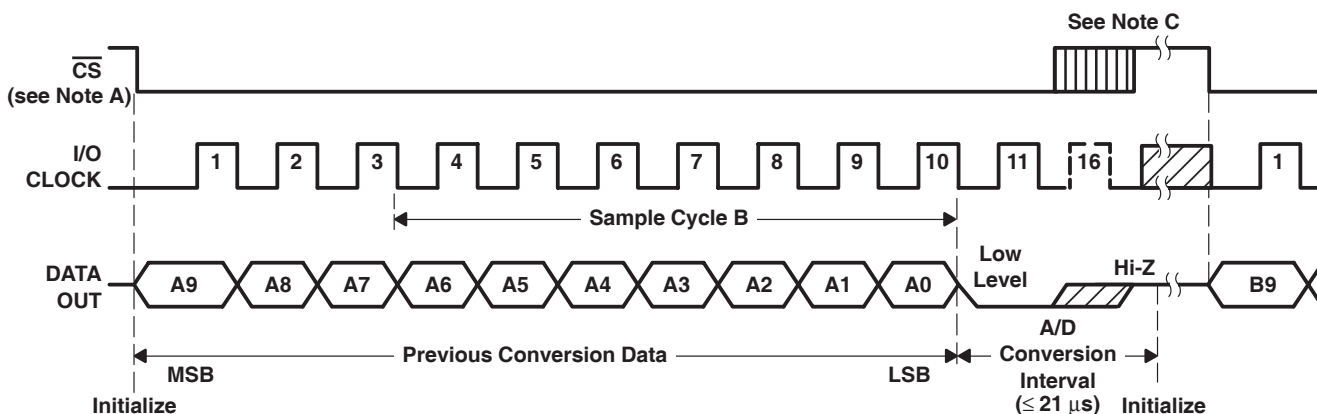

Figure 8. Timing for 11- to 16-Clock Transfer Using  $\overline{CS}$  (Serial Transfer Completed Within 21  $\mu$ s)

- NOTES:
- A. To minimize errors caused by noise at  $\overline{CS}$ , the internal circuitry waits for a setup time plus two falling edges of the internal system clock after  $\overline{CS}$  ↓ before responding to the I/O CLOCK. No attempt should be made to clock out the data until the minimum  $\overline{CS}$  setup time has elapsed.
  - B. A low-to-high transition of  $\overline{CS}$  disables I/O CLOCK within a maximum of a setup time plus two falling edges of the internal system clock.
  - C. The first I/O CLOCK must occur after the end of the previous conversion.

TLV1549C, TLV1549I, TLV1549M  
 10-BIT ANALOG-TO-DIGITAL CONVERTERS  
 WITH SERIAL CONTROL

SLAS071C – JANUARY 1993 – REVISED MARCH 1995

PARAMETER MEASUREMENT INFORMATION

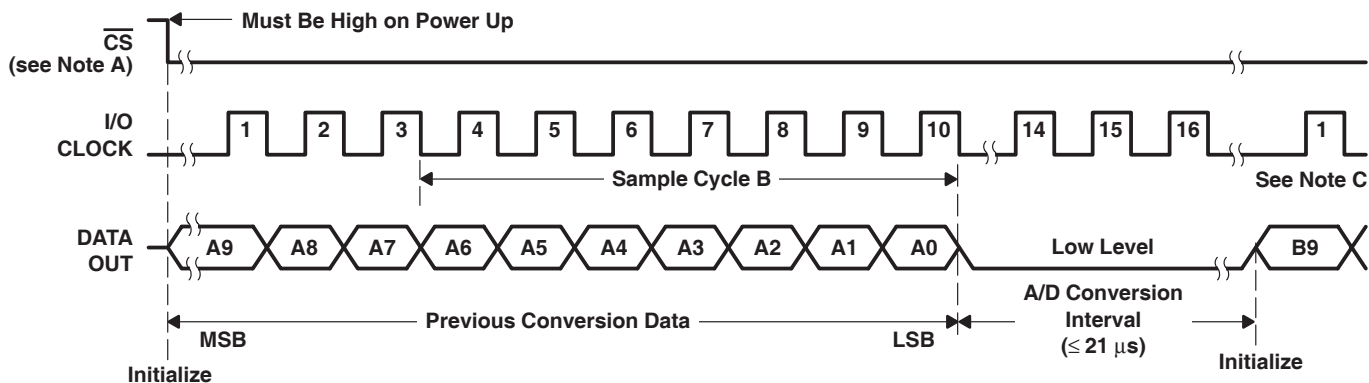

Figure 9. Timing for 16-Clock Transfer Not Using  $\overline{CS}$  (Serial Transfer Completed Within 21  $\mu s$ )

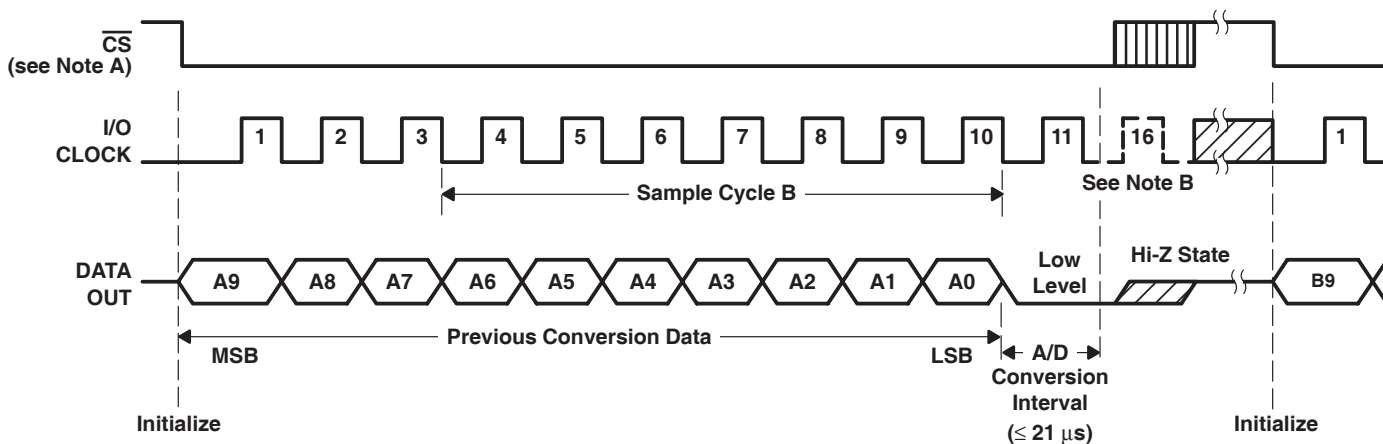

Figure 10. Timing for 11- to 16-Clock Transfer Using  $\overline{CS}$  (Serial Transfer Completed After 21  $\mu s$ )

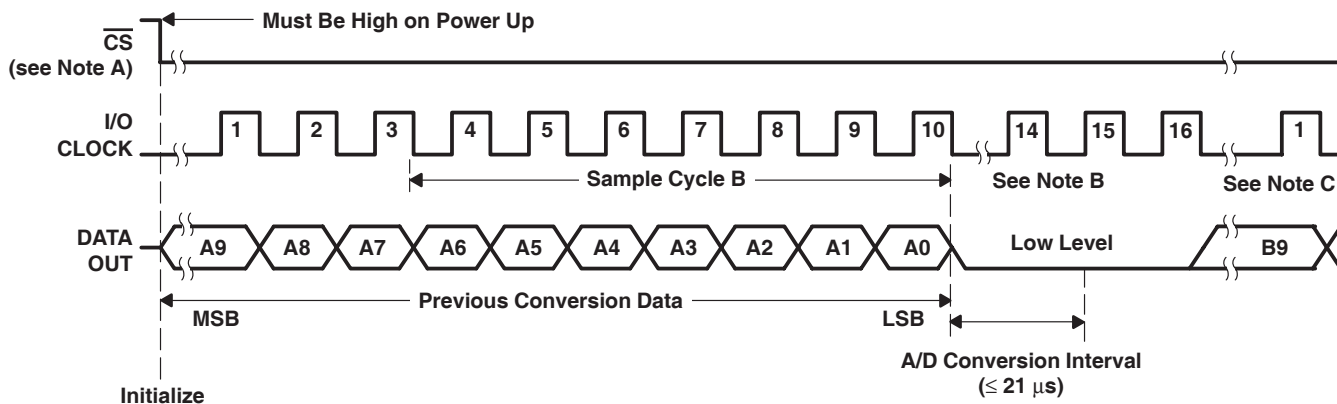
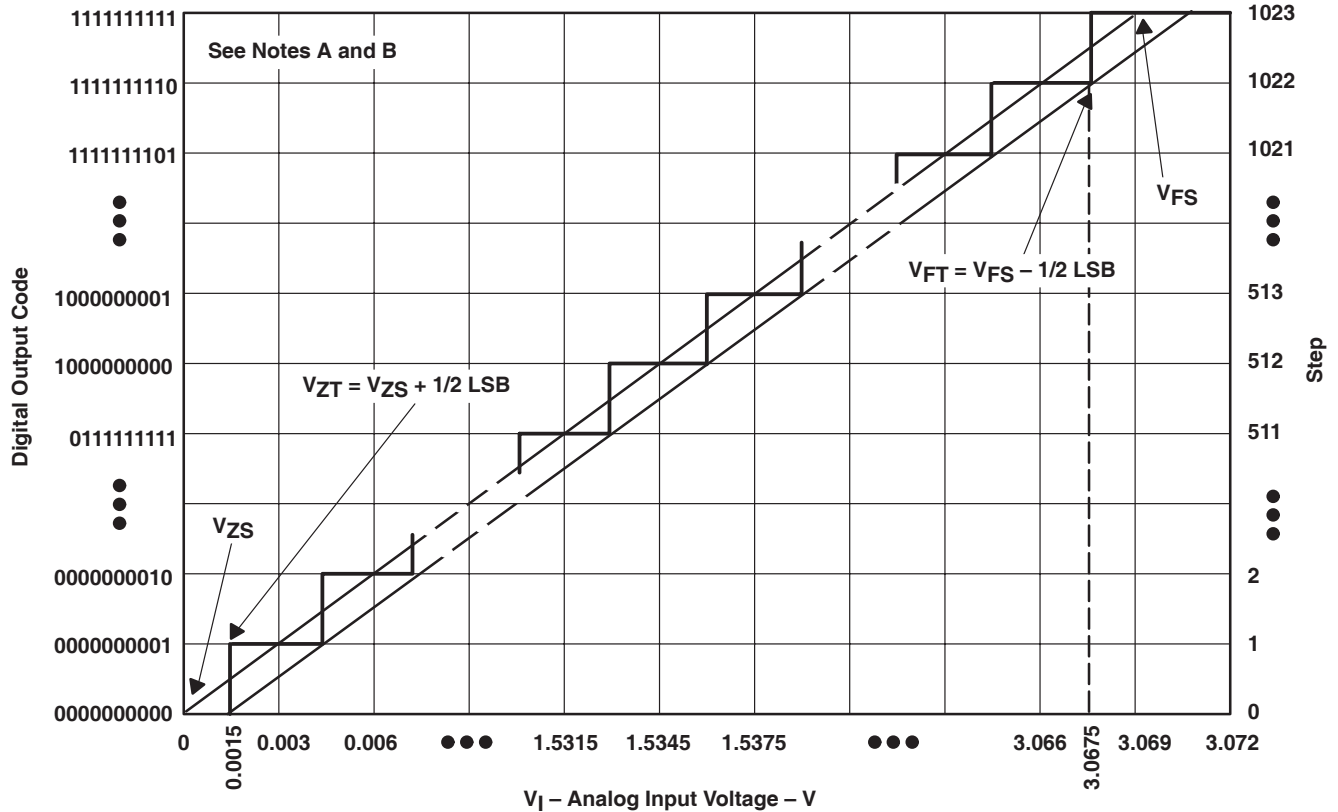

Figure 11. Timing for 16-Clock Transfer Not Using  $\overline{CS}$  (Serial Transfer Completed After 21  $\mu s$ )

- NOTES:
- A. To minimize errors caused by noise at  $\overline{CS}$ , the internal circuitry waits for a set up time plus two falling edges of the internal system clock after  $\overline{CS}\downarrow$  before responding to the I/O CLOCK. No attempt should be made to clock out the data until the minimum  $\overline{CS}$  setup time has elapsed.
  - B. A low-to-high transition of  $\overline{CS}$  disables I/O CLOCK within a maximum of a setup time plus two falling edges of the internal system clock.
  - C. The first I/O CLOCK must occur after the end of the previous conversion.



APPLICATION INFORMATION



- NOTES: A. This curve is based on the assumption that  $V_{ref+}$  and  $V_{ref-}$  have been adjusted so that the voltage at the transition from digital 0 to 1 ( $V_{ZT}$ ) is 0.0015 V and the transition to full scale ( $V_{FT}$ ) is 3.0675 V. 1 LSB = 3 mV.
- B. The full-scale value ( $V_{FS}$ ) is the step whose nominal midstep value has the highest absolute value. The zero-scale value ( $V_{ZS}$ ) is the step whose nominal midstep value equals zero.

Figure 12. Ideal Conversion Characteristics

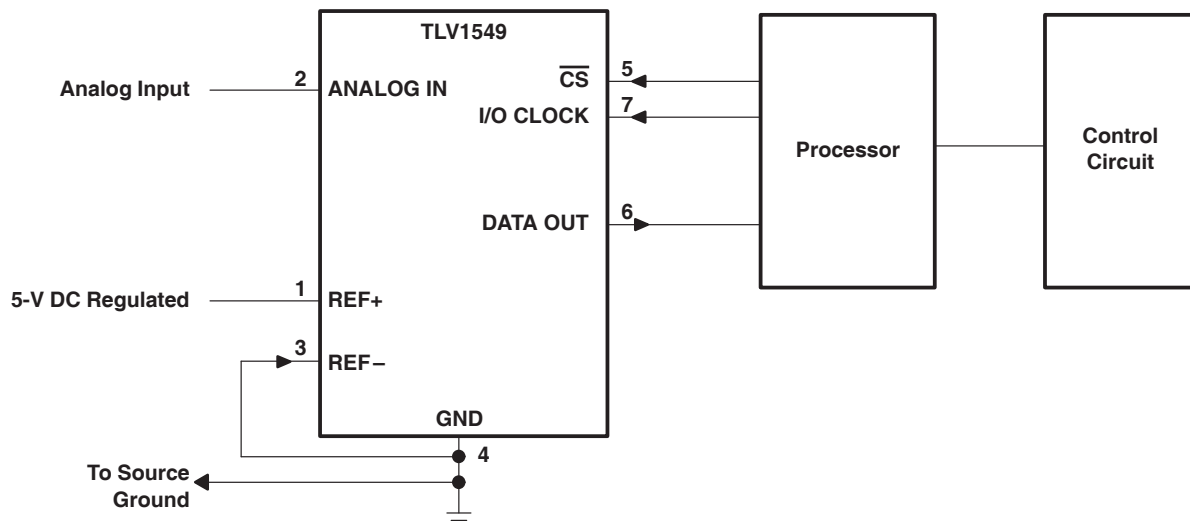

Figure 13. Typical Serial Interface

APPLICATION INFORMATION

simplified analog input analysis

Using the equivalent circuit in Figure 14, the time required to charge the analog input capacitance from 0 to  $V_S$  within 1/2 LSB can be derived as follows:

The capacitance charging voltage is given by

$$V_C = V_S \left( 1 - e^{-t_c / R_t C_i} \right) \tag{1}$$

where

$$R_t = R_s + r_i$$

The final voltage to 1/2 LSB is given by

$$V_C (1/2 \text{ LSB}) = V_S - (V_S / 2048) \tag{2}$$

Equating equation 1 to equation 2 and solving for time  $t_c$  gives

$$V_S - (V_S / 2048) = V_S \left( 1 - e^{-t_c / R_t C_i} \right) \tag{3}$$

and

$$t_c (1/2 \text{ LSB}) = R_t \times C_i \times \ln(2048) \tag{4}$$

Therefore, with the values given the time for the analog input signal to settle is

$$t_c (1/2 \text{ LSB}) = (R_s + 1 \text{ k}\Omega) \times 60 \text{ pF} \times \ln(2048) \tag{5}$$

This time must be less than the converter sample time shown in the timing diagrams.

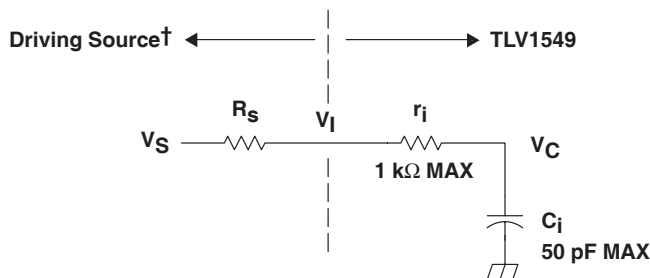

$V_I$  = Input Voltage at ANALOG IN  
 $V_S$  = External Driving Source Voltage  
 $R_s$  = Source Resistance  
 $r_i$  = Input Resistance  
 $C_i$  = Equivalent Input Capacitance

† Driving source requirements:

- Noise and distortion for the source must be equivalent to the resolution of the converter.
- $R_s$  must be real at the input frequency.

Figure 14. Equivalent Input Circuit Including the Driving Source

**PACKAGING INFORMATION**

Orderable Device	Status <sup>(1)</sup>	Package Type	Package Drawing	Pins	Package Qty	Eco Plan <sup>(2)</sup>	Lead/ Ball Finish	MSL Peak Temp <sup>(3)</sup>	Samples (Requires Login)
TLV1549CD	ACTIVE	SOIC	D	8	75	Green (RoHS & no Sb/Br)	CU NIPDAU	Level-1-260C-UNLIM	<a href="#">Request Free Samples</a>
TLV1549CDG4	ACTIVE	SOIC	D	8	75	Green (RoHS & no Sb/Br)	CU NIPDAU	Level-1-260C-UNLIM	<a href="#">Request Free Samples</a>
TLV1549CDR	ACTIVE	SOIC	D	8	2500	Green (RoHS & no Sb/Br)	CU NIPDAU	Level-1-260C-UNLIM	<a href="#">Purchase Samples</a>
TLV1549CDRG4	ACTIVE	SOIC	D	8	2500	Green (RoHS & no Sb/Br)	CU NIPDAU	Level-1-260C-UNLIM	<a href="#">Purchase Samples</a>
TLV1549CP	ACTIVE	PDIP	P	8	50	Pb-Free (RoHS)	CU NIPDAU	N / A for Pkg Type	<a href="#">Request Free Samples</a>
TLV1549CPE4	ACTIVE	PDIP	P	8	50	Pb-Free (RoHS)	CU NIPDAU	N / A for Pkg Type	<a href="#">Request Free Samples</a>
TLV1549ID	ACTIVE	SOIC	D	8	75	Green (RoHS & no Sb/Br)	CU NIPDAU	Level-1-260C-UNLIM	<a href="#">Request Free Samples</a>
TLV1549IDG4	ACTIVE	SOIC	D	8	75	Green (RoHS & no Sb/Br)	CU NIPDAU	Level-1-260C-UNLIM	<a href="#">Request Free Samples</a>
TLV1549IP	ACTIVE	PDIP	P	8	50	Pb-Free (RoHS)	CU NIPDAU	N / A for Pkg Type	<a href="#">Request Free Samples</a>
TLV1549IPE4	ACTIVE	PDIP	P	8	50	Pb-Free (RoHS)	CU NIPDAU	N / A for Pkg Type	<a href="#">Request Free Samples</a>

<sup>(1)</sup> The marketing status values are defined as follows:

**ACTIVE:** Product device recommended for new designs.

**LIFEBUY:** TI has announced that the device will be discontinued, and a lifetime-buy period is in effect.

**NRND:** Not recommended for new designs. Device is in production to support existing customers, but TI does not recommend using this part in a new design.

**PREVIEW:** Device has been announced but is not in production. Samples may or may not be available.

**OBSELETE:** TI has discontinued the production of the device.

<sup>(2)</sup> Eco Plan - The planned eco-friendly classification: Pb-Free (RoHS), Pb-Free (RoHS Exempt), or Green (RoHS & no Sb/Br) - please check <http://www.ti.com/productcontent> for the latest availability information and additional product content details.

**TBD:** The Pb-Free/Green conversion plan has not been defined.

**Pb-Free (RoHS):** TI's terms "Lead-Free" or "Pb-Free" mean semiconductor products that are compatible with the current RoHS requirements for all 6 substances, including the requirement that lead not exceed 0.1% by weight in homogeneous materials. Where designed to be soldered at high temperatures, TI Pb-Free products are suitable for use in specified lead-free processes.

**Pb-Free (RoHS Exempt):** This component has a RoHS exemption for either 1) lead-based flip-chip solder bumps used between the die and package, or 2) lead-based die adhesive used between the die and leadframe. The component is otherwise considered Pb-Free (RoHS compatible) as defined above.

**Green (RoHS & no Sb/Br):** TI defines "Green" to mean Pb-Free (RoHS compatible), and free of Bromine (Br) and Antimony (Sb) based flame retardants (Br or Sb do not exceed 0.1% by weight in homogeneous material)

<sup>(3)</sup> MSL, Peak Temp. -- The Moisture Sensitivity Level rating according to the JEDEC industry standard classifications, and peak solder temperature.

**Important Information and Disclaimer:** The information provided on this page represents TI's knowledge and belief as of the date that it is provided. TI bases its knowledge and belief on information provided by third parties, and makes no representation or warranty as to the accuracy of such information. Efforts are underway to better integrate information from third parties. TI has taken and continues to take reasonable steps to provide representative and accurate information but may not have conducted destructive testing or chemical analysis on incoming materials and chemicals. TI and TI suppliers consider certain information to be proprietary, and thus CAS numbers and other limited information may not be available for release.

In no event shall TI's liability arising out of such information exceed the total purchase price of the TI part(s) at issue in this document sold by TI to Customer on an annual basis.

## TAPE AND REEL INFORMATION

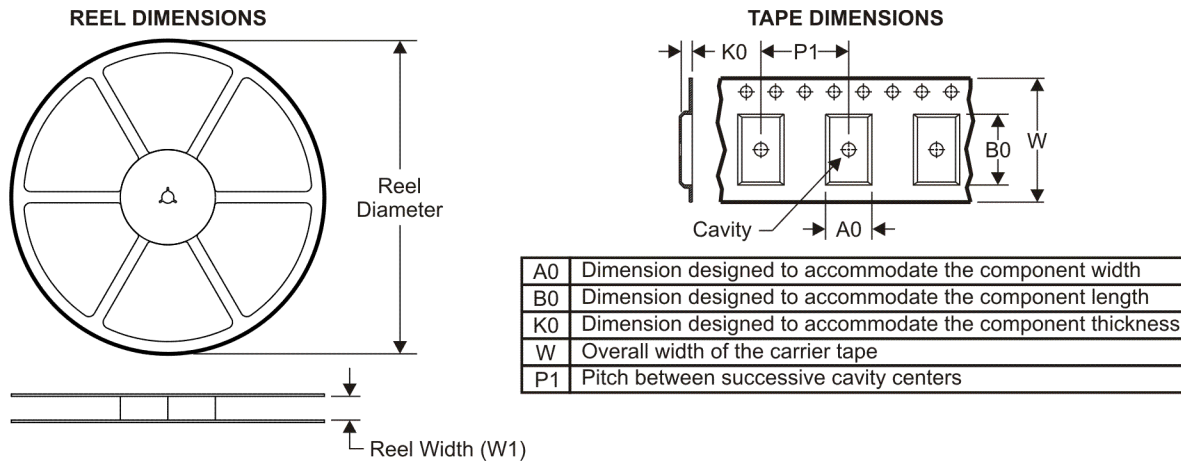

### QUADRANT ASSIGNMENTS FOR PIN 1 ORIENTATION IN TAPE



\*All dimensions are nominal

Device	Package Type	Package Drawing	Pins	SPQ	Reel Diameter (mm)	Reel Width W1 (mm)	A0 (mm)	B0 (mm)	K0 (mm)	P1 (mm)	W (mm)	Pin1 Quadrant
TLV1549CDR	SOIC	D	8	2500	330.0	12.4	6.4	5.2	2.1	8.0	12.0	Q1

TAPE AND REEL BOX DIMENSIONS



\*All dimensions are nominal

Device	Package Type	Package Drawing	Pins	SPQ	Length (mm)	Width (mm)	Height (mm)
TLV1549CDR	SOIC	D	8	2500	346.0	346.0	29.0

## IMPORTANT NOTICE

Texas Instruments Incorporated and its subsidiaries (TI) reserve the right to make corrections, modifications, enhancements, improvements, and other changes to its products and services at any time and to discontinue any product or service without notice. Customers should obtain the latest relevant information before placing orders and should verify that such information is current and complete. All products are sold subject to TI's terms and conditions of sale supplied at the time of order acknowledgment.

TI warrants performance of its hardware products to the specifications applicable at the time of sale in accordance with TI's standard warranty. Testing and other quality control techniques are used to the extent TI deems necessary to support this warranty. Except where mandated by government requirements, testing of all parameters of each product is not necessarily performed.

TI assumes no liability for applications assistance or customer product design. Customers are responsible for their products and applications using TI components. To minimize the risks associated with customer products and applications, customers should provide adequate design and operating safeguards.

TI does not warrant or represent that any license, either express or implied, is granted under any TI patent right, copyright, mask work right, or other TI intellectual property right relating to any combination, machine, or process in which TI products or services are used. Information published by TI regarding third-party products or services does not constitute a license from TI to use such products or services or a warranty or endorsement thereof. Use of such information may require a license from a third party under the patents or other intellectual property of the third party, or a license from TI under the patents or other intellectual property of TI.

Reproduction of TI information in TI data books or data sheets is permissible only if reproduction is without alteration and is accompanied by all associated warranties, conditions, limitations, and notices. Reproduction of this information with alteration is an unfair and deceptive business practice. TI is not responsible or liable for such altered documentation. Information of third parties may be subject to additional restrictions.

Resale of TI products or services with statements different from or beyond the parameters stated by TI for that product or service voids all express and any implied warranties for the associated TI product or service and is an unfair and deceptive business practice. TI is not responsible or liable for any such statements.

TI products are not authorized for use in safety-critical applications (such as life support) where a failure of the TI product would reasonably be expected to cause severe personal injury or death, unless officers of the parties have executed an agreement specifically governing such use. Buyers represent that they have all necessary expertise in the safety and regulatory ramifications of their applications, and acknowledge and agree that they are solely responsible for all legal, regulatory and safety-related requirements concerning their products and any use of TI products in such safety-critical applications, notwithstanding any applications-related information or support that may be provided by TI. Further, Buyers must fully indemnify TI and its representatives against any damages arising out of the use of TI products in such safety-critical applications.

TI products are neither designed nor intended for use in military/aerospace applications or environments unless the TI products are specifically designated by TI as military-grade or "enhanced plastic." Only products designated by TI as military-grade meet military specifications. Buyers acknowledge and agree that any such use of TI products which TI has not designated as military-grade is solely at the Buyer's risk, and that they are solely responsible for compliance with all legal and regulatory requirements in connection with such use.

TI products are neither designed nor intended for use in automotive applications or environments unless the specific TI products are designated by TI as compliant with ISO/TS 16949 requirements. Buyers acknowledge and agree that, if they use any non-designated products in automotive applications, TI will not be responsible for any failure to meet such requirements.

Following are URLs where you can obtain information on other Texas Instruments products and application solutions:

<b>Products</b>		<b>Applications</b>	
Amplifiers	<a href="http://amplifier.ti.com">amplifier.ti.com</a>	Audio	<a href="http://www.ti.com/audio">www.ti.com/audio</a>
Data Converters	<a href="http://dataconverter.ti.com">dataconverter.ti.com</a>	Automotive	<a href="http://www.ti.com/automotive">www.ti.com/automotive</a>
DLP® Products	<a href="http://www.dlp.com">www.dlp.com</a>	Communications and Telecom	<a href="http://www.ti.com/communications">www.ti.com/communications</a>
DSP	<a href="http://dsp.ti.com">dsp.ti.com</a>	Computers and Peripherals	<a href="http://www.ti.com/computers">www.ti.com/computers</a>
Clocks and Timers	<a href="http://www.ti.com/clocks">www.ti.com/clocks</a>	Consumer Electronics	<a href="http://www.ti.com/consumer-apps">www.ti.com/consumer-apps</a>
Interface	<a href="http://interface.ti.com">interface.ti.com</a>	Energy	<a href="http://www.ti.com/energy">www.ti.com/energy</a>
Logic	<a href="http://logic.ti.com">logic.ti.com</a>	Industrial	<a href="http://www.ti.com/industrial">www.ti.com/industrial</a>
Power Mgmt	<a href="http://power.ti.com">power.ti.com</a>	Medical	<a href="http://www.ti.com/medical">www.ti.com/medical</a>
Microcontrollers	<a href="http://microcontroller.ti.com">microcontroller.ti.com</a>	Security	<a href="http://www.ti.com/security">www.ti.com/security</a>
RFID	<a href="http://www.ti-rfid.com">www.ti-rfid.com</a>	Space, Avionics & Defense	<a href="http://www.ti.com/space-avionics-defense">www.ti.com/space-avionics-defense</a>
RF/IF and ZigBee® Solutions	<a href="http://www.ti.com/lprf">www.ti.com/lprf</a>	Video and Imaging	<a href="http://www.ti.com/video">www.ti.com/video</a>
		Wireless	<a href="http://www.ti.com/wireless-apps">www.ti.com/wireless-apps</a>